

Maine Medical Center East Tower

22 Bramhall Street, Portland, ME

PROJECT MANUAL VOLUME 2

Specification Divisions 21 - 28

Construction Documents, 26 January 2018

Addendum 1, 22 March 2018

Addendum 2, 29 March 2018

Project # 152181.000



PERKINS+WILL

TABLE OF CONTENTS

VOLUME 1

PROCUREMENT AND CONTRACTING DOCUMENTS GROUP

DIVISION 00 - PROCUREMENT AND CONTRACTING REQUIREMENTS

- COVER PAGE VOLUME 1
 - TABLE OF CONTENTS
- SEE MAIN MEDICAL CENTER DIVISION 00 – 01 DOCUMENTS, 29 SEPTEMBER 2017.
- 00 73 16 INSURERS REQUIREMENTS
 - 00 91 13.01 ADDENDUM 1 – East Tower 6 & 7 Addition
 - 00 91 13.02 ADDENDUM 2 – East Tower 6 & 7 Addition

DIVISION 01 - GENERAL REQUIREMENTS

- 01 22 00 UNIT PRICES
- 01 23 00 ALTERNATES
- 01 43 39 ROOM MOCKUP REQUIREMENTS
- 01 45 34 FIELD MOCKUP FOR EXTERIOR WALL SYSTEMS
- 01 45 35 QUALITY CONTROL AND ASSURANCE OF AIR BARRIER SYSTEM
- 01 50 00 TEMPORARY FACILITIES AND CONTROLS
- 01 73 00 EXECUTION
- 01 81 13 SUSTAINABLE DESIGN REQUIREMENTS - LEED v4 FOR HEALTH CARE FACILITIES
- 01 91 00 BUILDING SYSTEMS COMMISSIONING REQUIREMENTS
- 01 91 19 BUILDING ENCLOSURE COMMISSIONING
- 01 91 19A BUILDING ENCLOSURE COMMISSIONING APPENDIX A

SPECIFICATIONS GROUP

DIVISION 02 - EXISTING CONDITIONS

- 02 41 19 SELECTIVE DEMOLITION

DIVISION 03 - CONCRETE

- 03 30 00 CAST IN PLACE CONCRETE (See Early Structural Package 10/20/2017)

DIVISION 05 - METALS

- 05 12 00 STRUCTURAL STEEL (See Early Structural Package 10/20/2017)
- 05 31 00 STEEL DECKING
- 05 40 00 COLD-FORMED METAL FRAMING
- 05 50 00 METAL FABRICATIONS
- 05 51 13 METAL PAN STAIRS
- 05 51 19 METAL GRATING STAIRS
- 05 52 13 PIPE AND TUBE RAILINGS
- 05 55 00 FABRICATED METAL SYSTEMS
- 05 75 00 DECORATIVE FORMED METAL

DIVISION 06 - WOOD, PLASTICS, AND COMPOSITES

06 10 53	MISCELLANEOUS ROUGH CARPENTRY
06 16 00	SHEATHING
06 41 13	WOOD-VENEER-FACED ARCHITECTURAL CABINETS
06 41 16	PLASTIC-LAMINATE-FACED ARCHITECTURAL CABINETS
06 42 16	FLUSH WOOD PANELING
06 42 19	PLASTIC-LAMINATE-FACED WOOD PANELING
06 83 16	FIBERGLASS REINFORCED PLASTIC LAMINATE PANELING

DIVISION 07 - THERMAL AND MOISTURE PROTECTION

07 18 00	TRAFFIC COATING
07 21 00	THERMAL INSULATION
07 27 13	MODIFIED BITUMINOUS SHEET AIR BARRIERS
07 42 13.13	FORMED METAL WALL PANELS
07 42 13.19	INSULATED METAL WALL PANELS
07 42 13.23	METAL COMPOSITE MATERIAL WALL PANELS
07 53 23	ETHYLENE-PROPYLENE-DIENE-MONOMER (EPDM) ROOFING
07 62 00	SHEET METAL FLASHING AND TRIM
07 71 00	ROOF SPECIALTIES
07 72 00	ROOF ACCESSORIES
07 81 00	APPLIED FIREPROOFING
07 81 23	INTUMESCENT FIREPROOFING
07 84 13	PENETRATION FIRESTOPPING
07 84 43	JOINT FIRESTOPPING
07 92 00	JOINT SEALANTS
07 95 00	EXPANSION CONTROL

DIVISION 08 - OPENINGS

08 11 13	HOLLOW METAL DOORS AND FRAMES
08 11 16	ALUMINUM DOORS AND FRAMES
08 14 16	FLUSH WOOD DOORS
08 31 13	ACCESS DOORS AND FRAMES
08 42 43	INTENSIVE CARE UNIT/CRITICAL CARE UNIT (ICU/CCU) ENTRANCES
08 44 13	GLAZED ALUMINUM CURTAIN WALLS
08 71 00	DOOR HARDWARE
08 80 00	GLAZING
08 81 13	DECORATIVE GLASS GLAZING
08 83 00	MIRRORS
08 88 36	SWITCHABLE GLASS

DIVISION 09 - FINISHES

09 05 61.13	MOISTURE VAPOR EMISSION CONTROL
09 21 16.23	GYPSUM BOARD SHAFT WALL ASSEMBLIES
09 22 16	NON-STRUCTURAL METAL FRAMING

09 29 00	GYPSUM BOARD
09 30 13	CERAMIC TILING
09 51 13	ACOUSTICAL PANEL CEILINGS
09 61 00	CONCRETE FLOOR TREATMENT
09 65 13	RESILIENT BASE AND ACCESSORIES
09 65 16	RESILIENT SHEET FLOORING
09 65 36	STATIC-CONTROL RESILIENT FLOORING
09 68 13	TILE CARPETING
09 72 00	WALL COVERINGS
09 75 23	SOLID-SURFACING WALL FACING
09 77 13	STRETCHED-FABRIC SYSTEMS
09 91 13	EXTERIOR PAINTING
09 91 23	INTERIOR PAINTING
09 96 00	HIGH PERFORMANCE COATINGS

DIVISION 10 - SPECIALTIES

10 11 00	VISUAL DISPLAY SURFACES
10 21 23	CUBICLE CURTAINS AND TRACKS
10 26 00	WALL PROTECTION
10 28 00	TOILET ACCESSORIES
10 31 00	MANUFACTURED FIREPLACES
10 44 00	FIRE PROTECTION SPECIALTIES
10 44 45	PHOTOLUMINESCENT EXIT PATH MARKINGS
10 77 36	WINDSOCK
10 81 13	BIRD CONTROL

DIVISION 11 - EQUIPMENT

11 24 29	FACILITY FALL PROTECTION
11 31 00	APPLIANCES
11 70 05	MEDICAL EQUIPMENT

DIVISION 12 - FURNISHINGS

12 24 13	ROLLER WINDOW SHADES
12 36 23	PLASTIC-LAMINATE-CLAD COUNTERTOPS
12 36 61	SIMULATED STONE COUNTERTOPS

DIVISION 14 - CONVEYING EQUIPMENT

14 21 23	ELECTRICAL TRACTION ELEVATORS
14 91 35	LAUNDRY CHUTES
14 92 00	PNEUMATIC TUBE SYSTEM

TABLE OF CONTENTS CONTINUES

TABLE OF CONTENTS

VOLUME 2

- COVER PAGE VOLUME 2
- TABLE OF CONTENTS

DIVISION 21 - FIRE PROTECTION

- 21 00 00 FIRE PROTECTION GENERAL PROVISIONS
- 21 05 00 COMMON WORK RESULTS FOR FIRE SUPPRESSION
- 21 10 00 WATER-BASED FIRE-SUPPRESSION SYSTEMS

DIVISION 22 - PLUMBING

- 22 00 00 PLUMBING GENERAL PROVISIONS
- 22 05 00 COMMON WORK RESULTS FOR PLUMBING
- 22 05 13 COMMON MOTOR REQUIREMENTS FOR PLUMBING EQUIPMENT
- 22 05 16 EXPANSION FITTINGS AND LOOPS FOR PLUMBING PIPING
- 22 05 19 METERS AND GAGES FOR PLUMBING PIPING
- 22 05 23 GENERAL-DUTY VALVES FOR PLUMBING PIPING
- 22 05 29 HANGERS AND SUPPORTS FOR PLUMBING PIPING AND
- 22 05 53 IDENTIFICATION FOR PLUMBING AND PIPING EQUIPMENT
- 22 07 00 PLUMBING INSULATION
- 22 11 16 DOMESTIC WATER PIPING
- 22 11 19 DOMESTIC WATER PIPING SPECIALTIES
- 22 11 23 DOMESTIC WATER PUMPS
- 22 13 16 SANITARY WASTE, VENT PIPING AND STORM DRAINAGE
- 22 13 19 SANITARY WASTE PIPING SPECIALTIES
- 22 14 23 STORM DRAINAGE PIPING SPECIALTIES
- 22 35 00 DOMESTIC WATER HEAT EXCHANGERS
- 22 40 00 PLUMBING FIXTURES
- 22 62 19 VACUUM EQUIPMENT FOR LABORATORY AND HEALTHCARE FACILITIES
- 22 63 13 GAS PIPING FOR LABORATORY AND HEALTHCARE FACILITIES

DIVISION 23 - HEATING, VENTILATING, AND AIR CONDITIONING (HVAC)

- 23 00 00 GENERAL PROVISIONS FOR HEATING, VENTILATING AND AIR
CONDITIONING
- 23 00 01 SUPPLEMENTARY CONDITIONS FOR MECHANICAL, ELECTRICAL,
PLUMBING AND AIR CONDITIONING
- 23 05 00 COMMON WORK RESULTS FOR HVAC
- 23 05 12 BEARING PROTECTION RING FOR MOTORS
- 23 05 13 COMMON MOTOR REQUIREMENTS FOR HVAC EQUIPMENT
- 23 05 14 ENCLOSED CONTROLLERS
- 23 05 15 VARIABLE-FREQUENCY MOTOR CONTROLLERS
- 23 05 16 EXPANSION FITTINGS AND LOOPS FOR HVAC PIPING
- 23 05 19 METERS AND GAGES FOR HVAC PIPING
- 23 05 23 GENERAL-DUTY VALVES FOR HVAC PIPING

23 05 29	HANGERS AND SUPPORTS FOR HVAC PIPING AND EQUIPMENT
23 05 33	HEAT TRACING FOR HVAC PIPING
23 05 48	MECHANICAL VIBRATION ISOLATION AND SEISMIC RESTRAINT SYSTEMS
23 05 49	NOISE CONTROL AND ACOUSTICAL PERFORMANCE
23 05 53	IDENTIFICATION FOR HVAC PIPING AND EQUIPMENT
23 05 93	TESTING, ADJUSTING, AND BALANCING FOR HVAC
23 07 00	HVAC INSULATION
23 08 00	COMMISSIONING OF HVAC
23 09 00	HVAC INSTRUMENTATION AND CONTROLS
23 09 93	SEQUENCE OF OPERATIONS
23 21 13	HYDRONIC PIPING
23 21 23	HYDRONIC PUMPS
23 22 13	STEAM AND CONDENSATE HEATING PIPING
23 22 23	STEAM CONDENSATE PUMPS
23 25 00	HVAC WATER TREATMENT
23 31 13	METAL DUCTS
23 33 00	AIR DUCT ACCESSORIES
23 34 16	CENTRIFUGAL HVAC FANS
23 34 23	HVAC POWER VENTILATORS
23 36 00	AIR TERMINAL UNITS
23 37 13	DIFFUSERS, REGISTERS, AND GRILLES
23 57 00	HEAT EXCHANGERS FOR HVAC
23 73 14	CUSTOM PACKAGED CENTRAL-STATION AIR-HANDLING UNITS
23 74 13	PACKAGED, OUTDOOR, CENTRAL-STATION AIR-CONDITIONING UNITS
23 81 26	SPLIT-SYSTEM AIR-CONDITIONERS
23 82 29	UNIT HEATERS
23 83 16	HYDRONIC RADIANT SNOW MELT SYSTEM
23 83 23	RADIANT-HEATING PANELS
23 84 13	HUMIDIFIERS

DIVISION 26 - ELECTRICAL

26 00 00	GENERAL PROVISIONS FOR ELECTRICAL WORK
26 00 01	SUPPLEMENTARY CONDITIONS FOR MECHANICAL, ELECTRICAL, PLUMBING AND FIRE PROTECTION WORK
26 05 00	COMMON WORK RESULTS FOR ELECTRICAL
26 05 19	LOW-VOLTAGE ELECTRICAL POWER CONDUCTORS AND CABLES
26 05 26	GROUNDING AND BONDING FOR ELECTRICAL SYSTEMS
26 05 29	HANGERS AND SUPPORTS FOR ELECTRICAL SYSTEMS
26 05 33	RACEWAY AND BOXES FOR ELECTRICAL SYSTEMS
26 05 53	IDENTIFICATION FOR ELECTRICAL SYSTEMS
26 05 73	OVERCURRENT PROTECTIVE DEVICE COORDINATION STUDY
26 09 23	LIGHTING CONTROL DEVICES
26 22 00	LOW-VOLTAGE TRANSFORMERS
26 24 16	PANELBOARDS
26 27 26	WIRING DEVICES

26 28 16	ENCLOSED SWITCHES AND CIRCUIT BREAKERS
26 41 13	LIGHTNING PROTECTION SYSTEM
26 51 00	INTERIOR LIGHTING

DIVISION 27 - COMMUNICATIONS

-	NETWORK ENGINEERING INFRASTRUCTURE
27 05 00	COMMON WORK RESULTS FOR COMMUNICATIONS
27 05 26	GROUNDING AND BONDING FOR COMMUNICATIONS SYSTEMS
27 11 00	COMMUNICATIONS EQUIPMENT ROOM FITTINGS
27 13 00	COMMUNICATIONS BACKBONE CABLING
27 15 00	COMMUNICATIONS HORIZONTAL CABLING
27 40 00	PUBLIC ADDRESS SYSTEM
27 52 23	NURSE CALL SYSTEM
27 53 19	DISTRIBUTED ANTENNA SYSTEM

DIVISION 28 - ELECTRONIC SAFETY AND SECURITY

28 10 00	SECURITY SYSTEM
28 31 11	FIRE ALARM EXTENSION
28 31 11.11	BI-DIRECTIONAL ANTENNA SYSTEM
28 41 11	AREA OF RESCUE ASSISTANCE INTERCOM SYSTEM

END OF TABLE OF CONTENTS

TABLE OF CONTENTS

FIRE PROTECTION

SECTION NUMBER	SECTION TITLE
21 00 00	FIRE PROTECTION GENERAL PROVISIONS
21 05 00	COMMON WORK RESULTS FOR FIRE SUPPRESSION
21 10 00	WATER-BASED FIRE-SUPPRESSION SYSTEMS

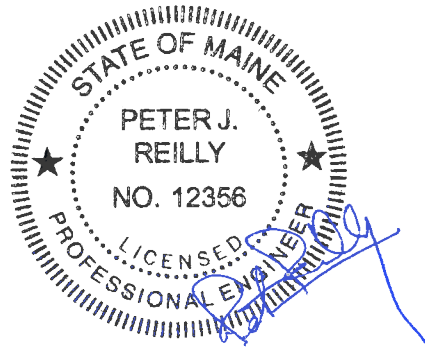

This page is intentionally left blank.

SECTION 21 00 00

FIRE PROTECTION GENERAL PROVISIONS

PART 1 - GENERAL

1.1 GENERAL REQUIREMENTS

- A. Work under this Section as shown or specified shall be in accordance with the requirements of the Contract Documents.

1.2 DEFINITIONS

- A. "Provide": to supply, install and make complete, safe, and operable, the particular work referred to unless specifically indicated otherwise.
- B. "Install": to erect, mount, and make complete with all related accessories.
- C. "Furnish" or "supply": to purchase, procure, acquire, and deliver complete with related accessories.
- D. "Work": labor, materials, equipment, services, and all related accessories necessary for the proper and complete installation of complete systems.
- E. "Piping": pipe, tube, fittings, flanges, valves, controls, strainers, hangers, supports, unions, traps, drains, insulation and all related accessories.
- F. "Wiring": raceway, fittings, wire, boxes and all related accessories.
- G. "Indicated," "shown" or "noted": as indicated, shown, or noted on drawings or specifications.
- H. "Similar" or "equal": of base bid manufacturer, equal in quality materials, weight, size, performance, design, and efficiency of specified product, conforming with "Base Bid Manufacturers".
- I. "Reviewed" "satisfactory," "accepted", or "directed": as reviewed, satisfactory, accepted, or directed by Architect and/or Engineer.
- J. "Motor Controllers": manual or magnetic starters with or without switches, individual pushbuttons or hand-off-automatic (HOA) switches controlling the operation of motors.
- K. "Control or Actuating Devices": automatic sensing and switching devices such as thermostats, pressure, float, flow operation of equipment.
- L. Finished Spaces: Spaces other than mechanical and electrical equipment rooms, furred spaces, pipe and duct shafts, unheated spaces immediately below roof, spaces above ceilings, unexcavated spaces, crawl spaces, and tunnels.
- M. Exposed, Interior Installations: Exposed to view indoors. Examples include finished occupied spaces and mechanical equipment rooms.
- N. Exposed, Exterior Installations: Exposed to view outdoors, or subject to outdoor ambient temperatures and weather conditions. Examples include rooftop locations.
- O. Concealed, Interior Installations: Concealed from view and protected from physical contact by building occupants. Examples include above ceilings and in duct shafts.

- P. Concealed, Exterior Installations: Concealed from view and protected from weather conditions and physical contact by building occupants, but subject to outdoor ambient temperatures. Examples include installations within unheated shelters.
- Q. The following are industry abbreviations for plastic materials:
 - 1. ABS: Acrylonitrile-butadiene-styrene plastic.
 - 2. CPVC: Chlorinated polyvinyl chloride plastic.
 - 3. NP: Nylon plastic.
 - 4. PE: Polyethylene plastic.
 - 5. PVC: Polyvinyl chloride plastic.
- R. The following are industry abbreviations for rubber materials:
 - 1. CR: Chlorosulfonated polyethylene synthetic rubber.
 - 2. EPDM: Ethylene propylene diene terpolymer rubber.

1.3 WORK INCLUDED

- A. The work covered by this section includes the construction described in the Contract Documents including all labor necessary to perform and complete such construction, all materials and equipment incorporated or to be incorporated in such construction, and all services, facilities, tools and equipment necessary or used to perform and complete such construction. The work includes, but is not limited to the following:
 - 1. Sprinkler Systems and Equipment.
 - 2. Piping, Valves and Fittings.
 - 3. Identification System.
 - 4. Hydraulic Calculations.
 - 5. Cutting, Patching and Equipment Painting.
 - 6. Hangers, Supports and Guides.
 - 7. Alarm Wiring, except for Fire Alarm.
 - 8. Rigging of Equipment.
 - 9. Furnishing access Doors and Frames to be installed under another section.
 - 10. Fire Stopping for Pipe Penetration.
 - 11. Pipe Penetration.
 - 12. Alarm Initiating Devices.
- B. Related Work not Included in this Division but Specified Elsewhere
 - 1. Fire Alarm Wiring.
 - 2. Finish painting, except for pre-finished equipment or as otherwise specified.
 - 3. Concrete work, except equipment inertia and floating bases.
 - 4. Base flashing for piping.
 - 5. Waterproofing.
 - 6. Power wiring for motors and motor controllers.
 - 7. Installation of access doors and frames.
- C. Sustainable Building Requirements:
 - 1. The Owner requires the Contractor to implement practices and procedures to meet the project's environmental performance goals, which include achieving LEED version 4 **Certified** level Certification. Specific project goals that may impact this area of work include: use of recycled-content materials; use of locally-manufactured materials; use of low-emitting materials; construction waste recycling; and the implementation of a construction indoor air quality management plan. The Contractor shall ensure that the requirements related to these goals, as defined in the Articles below, are implemented to the fullest extent. Substitutions, or other changes to the work proposed by the Contractor

or their Subcontractors, shall not be allowed if such changes compromise the aforementioned environmental goals and LEED certification.

1.4 COORDINATION OF WORK

- A. The fire protection drawings show the general arrangement of piping and appurtenances. Follow these drawings as closely as the actual construction will permit. Conform the fire protection work to the requirements shown on the drawings. Provide offsets, fittings, and accessories, which may be required but not shown on the drawings. Investigate the site, structural and finish ground conditions affecting the work, and arrange the work accordingly. Provide such work and accessories as may be required to meet such conditions.
- B. Certain materials will be provided by other trades. Examine the Contract Documents to ascertain these requirements.
- C. Carefully check space requirements with other trades to insure that all material can be installed in the spaces allotted thereto including finished suspended ceilings.
- D. Transmit to other trades all information required for work to be provided under their sections, in ample time for installation.
- E. Wherever work interconnects with work of other trades, coordinate with the General Contractor to insure that necessary information is presented so all the necessary connections and equipment may be properly installed. Identify all items (valves, piping, equipment, etc.) In order that the General Contractor will know where to install access doors and panels.
- F. Consult with other trades regarding equipment so that, wherever possible, motors, motor controls, pumps and valves are of the same manufacturer.
- G. Furnish and set all sleeves for passage of pipes and conduits through structural masonry and concrete walls and floors and elsewhere as will be required for the proper protection of each pipe passing through building surfaces.
- H. Provide required supports and hangers for piping and equipment, designed so as not to exceed allowable loadings of structures.
- I. Examine and compare the contract drawings and specifications with the drawings and specifications of other disciplines and report any discrepancies between them to the General Contractor and obtain from him written instructions for changes necessary in the work of this section. Install and coordinate the work of this section in cooperation with the General Contractor installing interrelated work. Before installation, take proper provisions to avoid interferences. All changes required in the work of the contractor, caused by his neglect to do so, are to be made by him at his own expense.
- J. Wherever the work is of sufficient complexity, prepare additional detail drawings to scale similar to that of the design drawings, prepared on tracing medium of the same size as contract drawings. With these layouts, coordinate the work with the work of the General Contractor. Such detailed work is to be clearly identified on the drawings as to the area to which it applies. Submit these drawings to the Engineer for review. At completion, however, include a set of such drawings with each set of as-built drawings. When directed by the Engineer, submit drawings for review, clearly showing the work of this section and its relation to the work of other disciplines before commencing shop fabrication or erection in the field.
- K. Before commencing work, examine all adjoining work on which this work is in any way dependent for perfect workmanship and report any conditions, which prevent

performance of first class work. Become thoroughly familiar with actual existing conditions to which connections must be made or which must be changed or altered.

- L. Provide required anchor bolts, sleeves, inserts and supports. Direct location of anchor bolts, sleeves, inserts and supports to insure that they are properly installed. Any expense resulting from the improper location or installation of anchor bolts, sleeves, inserts and supports to be paid for by the contractor.
- M. Slots, chases, openings and recesses through floors, walls, ceilings, and roofs will be provided by the various trades in their respective materials. Properly locate such openings and be responsible for any cutting and patching caused by the neglect to do so.
- N. Adjust location of pipes, panels, equipment, etc., to accommodate the work to prevent interferences, both anticipated and encountered. Determine the exact route and location of each pipe prior to fabrication.
 - 1. Right-of-Way: Lines that pitch have the right-of-way over those that do not pitch, i.e., plumbing drains. Lines whose elevations cannot be changed have right-of-way over lines whose elevations can be changed.
 - 2. Make offsets, transitions and changes in direction in pipes as required to maintain proper head room and pitch on sloping lines whether or not indicated on the drawings. Furnish and install all air vents, drains, etc., as required to affect these offsets, transitions and changes in direction.
- O. Install all fire protection work to permit removal (without damage to other parts) of all other parts requiring periodic replacement or maintenance. Arrange pipes and equipment to permit access to valves, cocks, starters, motors, and control components, and to clear the openings of swinging doors and access panels.
- P. Provide access panels in equipment as required for inspection and maintenance of internal parts, etc.
- Q. This contractor shall coordinate his work with the work of other trades.
- R. Coordinated Composite Drawings
 - 1. The Contractor shall prepare full coordinated composite drawings for the mechanical, electrical and fire protection trades. The Contractor shall overlay each trade's work (in separate colors) on a sepia set of sheetmetal drawings. All conflicts and potential conflicts shall be clearly identified on the sepia sheetmetal drawings. This shall include but not be limited to conflicts with lights, equipment, piping, ductwork and supports of other trades, as well as conflicts with architectural and structural walls, columns, ceilings and structural beams. Contractor shall have representatives of each trades, as well as conflicts with architectural and structural walls, columns, ceilings and structural beams. Contractor shall have representatives of each trade attend a weekly job site coordination meeting in the Contractor's field office. All trades shall resolve conflicts at these meetings and sign off each sepia sheetmetal drawing indicating acceptance and satisfactory resolution to all conflicts. All conflicts that cannot be resolved shall be brought to the attention of the Engineer for resolution.

1.5 USE OF SITE AND LOAD LIMITATIONS

- A. The contractor shall review all available data on the location and types of pipelines and other underground utilities. The contractor shall not operate equipment over the facilities and shall take care not to damage them or otherwise impair their use.

The contractor shall make investigation to verify the location of these facilities before proceeding with construction and/or operations in their vicinity.

1.6 CONTRACTOR'S RESPONSIBILITY FOR EVALUATION

- A. The Engineer and Owner make no representations, regarding the character or extent of the subsoils, water levels, existing structural, mechanical and electrical installations, above or below ground or other subsurface conditions which may be encountered during the Work. The contractor must make his own evaluation of existing conditions, which may affect methods or cost of performing the Work, based on his own examination of the facility or other information. Failure to examine the drawings or other information shall not relieve the contractor of his responsibility for satisfactory accomplishment of the Work.
- B. The locations of existing services are believed to be as indicated on the drawings. The contractor shall verify the actual location of these services and notify the Engineer of any discrepancies prior to commencing work.

1.7 ACCESS TO FIRE PROTECTION EQUIPMENT

- A. The contractor shall not interfere with access to hydrants, fire exits, fire hose stations, fire extinguishers, and fire alarm pull stations. In no case shall the contractor's material or equipment be within twenty-five (25) feet of a hydrant or fire alarm pull station.

1.8 EQUIPMENT AND MATERIALS

- A. If products and materials are specified or indicated on the drawings for a specific item or system, the contractor shall use those products or materials. If products and materials are not listed in either of the above, use first class products and materials, in accordance with shop drawings.
- B. All products and materials shall be new, clean, free of defects and free of damage and corrosion.
- C. No permanent equipment shall be used to provide temporary services during construction.
- D. Ship and store all products and materials in a manner which will protect them from damage, weather and entry of debris. If items are damaged, do not install, but take immediate steps to obtain replacement or repair.
- E. Make certain that all materials selected directly, or by suppliers, conform to the requirements of the contract drawings and specification. Transmittal of such specifications and drawings, information to persons manufacturing and supplying materials to the project, and rigid adherence thereto, is the contractor's responsibility. Acceptance of a manufacturer's name by the Engineer does not release the contractor of the responsibility for providing materials, which comply in all respects with the requirements in the Contract Documents.
- F. Applicable equipment and materials to be listed by Underwriters' Laboratories and Manufactured in accordance with ASME, AWWA, NFPA or ANSI standards, and as approved by the local authorities having jurisdiction.
- G. Fully lubricate all equipment when installed and prior to final acceptance.
- H. Locate valves, access doors, etc., to be easily accessible, either in mechanical spaces or through access panels specified herein.

- I. Follow manufacturers' instructions for installing, connecting, and adjusting all equipment. Provide one copy of such instructions to the Engineer before installing any equipment. Provide a copy of such instructions at the equipment during any work on the equipment. Provide all special valves, piping, wiring and accessories.

1.9 QUALITY ASSURANCE

A. Codes Standards and Fees:

1. Codes and Standards:

- a. Comply with all current governing codes, ordinances and regulations, as well as with requirements of NFPA, UL and all other applicable codes.
- b. Comply with the requirements of the State adopted Building Code, NFPA and other agencies or authorities having jurisdiction over any part of the Work and secure all necessary permits.
- c. Where codes or standards are listed herein, the applicable portions apply.
- d. Plans, specifications, codes and standards are all minimum requirements. Where requirements differ, apply the more stringent.
- e. Should any change in plans or specifications be required to comply with governing regulations, the contractor is to notify the Engineer at the time of submitting his bid.
- f. The codes and standards listed in the Specifications can be obtained from the organizations listed as follows:

- 1) OSHA Occupational Safety and Health Act
- 2) ANSI American National Standard Institute, Inc.
- 3) ASME American Society of Mechanical Engineers
- 4) ASTM American Society for Testing and Materials
- 5) AWWA American Water Works Association
- 6) UL Underwriters Laboratories, Inc.
- 7) ASHRAE American Society of Heating, Refrigerating and Air Conditioning Engineers
- 8) NFPA National Fire Protection Association
- 9) NEMA National Electrical Manufacturers Association
- 10) AIA American Insurance Association
- 11) AWS American Welding Society
- 12) ASA American Standards Association
- 13) IEEE Institute of Electrical and Electronics Engineers
- 14) NEC National Electrical Code

- g. The particular specification will be identified by appropriate prefix and number only with the latest revision being applicable unless otherwise noted.

2. Fees

- a. Pay all required permit and/or inspection fees.
 - b. Pay royalties or fees required in connection with the use of patented devices and systems.
3. Furnish all materials and equipment new, free from defects and with listings or labels of Underwriter's Laboratories, Inc. or other nationally approved testing laboratory.
 4. All items of a given type shall be the product of the same manufacturer.

5. All materials and equipment shall be the product of manufacturers regularly engaged in their manufacture.

1.10 SHOP DRAWINGS

- A. Prepare and submit detailed shop drawings for piping work and other distribution services, including locations and sizes of all openings in floor walls and roofs.
- B. The work described in any shop drawing submission to be carefully checked for all clearances (including those required for maintenance and servicing), field conditions, maintenance of architectural conditions and proper coordination with all trades on the job.
- C. Each submitted shop drawing to include a certification that all related job conditions have been checked and that no conflict exists.
- D. All drawings are to be submitted sufficiently in advance of field requirements to allow ample time for checking. All submittals to be complete and contain all required and detailed information. Shop drawings with multiple parts to be submitted as a package.
- E. If submittals differ from the Contract Document requirements, make specific mention of such difference in a letter of transmittal, with request for substitution, together with reasons for same.
- F. Review of any submitted data or shop drawings for material, equipment, apparatus, devices, arrangement and layout shall not relieve the contractor from responsibility of furnishing same of proper dimensions and weight, capacities, sizes, quantity, quality and installation details to efficiently perform the requirements and intent of the Work. Such review shall not relieve the contractor from responsibility for errors, omissions or inadequacies of any sort on submitted data or shop drawings.
- G. Each shop drawing to contain job title, the names and phone numbers of the General Contractor and the contractor reference to the applicable design drawing or specification article, date and scale.
- H. Within 15 days after award of Contract, submit for review, a list of all material and equipment manufacturers whose products are proposed, as well as names of all subcontractors whom the General Contractor proposes to employ.
- I. Within three (3) weeks after award of Contract, submit a list of all shop drawings, which will be submitted in the course of the project. List to show disposition of each item, including date of submission, review, and the like. List to be kept up-to-date throughout entire construction period.
- J. Submit shop drawings and manufacturer's data for the following items in accordance with the Contract Documents:
 1. Coordinated, detailed shop layout drawings of all mechanical rooms, services and distribution systems, including plans, profiles and sections.
 2. Details of piping supports, elbows, anchors and miscellaneous appurtenances.
 3. Hangers, supports, inserts, anchors, guides and foundations.
 4. Valves.
 5. Pressure gauges.
 6. Corrosion protective coatings.
 7. Equipment and piping layouts at 3/8 in. scale for the building.
 8. Location and size of sleeves for openings in floors and walls.
 9. Schedule of pipe and fittings, materials and application, valves, escutcheons, air vents, valve tags and schedules, strainers, and water specialties.

10. Access doors.
11. Sound insulation, thermal insulation and vibration isolation.
12. Flashing.
13. Equipment identification and certificates.
14. Sprinkler heads and accessories.
15. Other shop drawings and submittals as requested within the specification.

1.11 SAMPLES

- A. Submit samples of all items with exposed finishes for review.
- B. Allow sufficient time for consideration without interfering with job schedule.
- C. Duplicate quality and finish to type to be supplied under contract.
- D. Identify similar to shop drawings.

1.12 ELECTRONIC COPIES OF AKF DRAWINGS

- A. Upon award of contract, contractor shall submit list of drawings that they will require. AKF will provide drawings in (.PDF) format only.
- B. If the contractor requires (.dwg) format, there will be a charge of \$200 for each drawing supplied plus shipping and handling for preparation and processing. After preparation the drawings will be forwarded only upon receipt of signed acceptance of terms form. Permission from the architect must first be obtained for AKF to include the architectural background as reference. The contractor is to obtain the architects latest drawings directly from the architect.
- C. These files are being issued for the convenience of the contractor and the contractor remains responsible for all contract requirements related to the normal shop drawing preparation process.

1.13 SUBMISSIONS:

- A. Provide all coordination drawings and shop drawings in 'AutoCad' format, version compatible with owner. All catalog cuts and submittals to be provided in electronic "PDF" format the architect will forward all submissions to the engineer.
- B. If paper submissions are to be provided the following shall be adhered to.
 1. Submissions 11 in. X 17 in. or smaller: If the submission is a catalog cut, then the contractor shall submit one original and one copy. Otherwise, they shall submit two copies. The architect will forward the original and one copy (two copies when no original is received) to the engineer. All catalog cuts shall be complete.
 2. Submissions larger than 11 in. X 17 in.: submit two copies to the architect. The architect will forward to the engineer.
- C. Indicate on each submission: project name and location, architect and engineer, item identification and approval stamp of prime contractor, subcontractor names and phone numbers, reference to the applicable design drawing or specification article, date and scale.
- D. The work described in all shop drawing submission shall be carefully checked for all clearances (including those required for maintenance and servicing), field conditions, maintenance of architectural conditions and proper coordination with all trades on the job.

- E. Each submitted shop drawing is to include a certification that all related job conditions have been checked and verified and that there are no conflicts.
- F. All shop drawings are to be submitted to allow ample time for checking in advance of field requirements. All submittals to be complete and contain all required and detailed information. Shop drawings with multiple parts shall be submitted as a package.
- G. If submittals differ from the contract document requirements, make specific mention of such difference in a letter of transmittal, with request for substitution, together with reasons for same.

1.14 AS-BUILTS AND EQUIPMENT OPERATION INSTRUCTIONS

- A. Provide all coordination drawings and shop drawings in AutoCad format, version compatible with owner. All catalog cuts and submittals to be provided in electronic "PDF" format the architect will forward all submissions to the engineer.
- B. On completion and acceptance of work, this contractor shall furnish written instructions, equipment manuals and demonstrate to the owner the proper operation and maintenance of all equipment and apparatus furnished under this contract.
- C. The contractor shall give one copy of the instructions to the owner and one copy to the engineer. .
- D. Final "as-built" drawings indicating as installed conditions shall be provided to the architect and engineer after completion of the installation.

1.15 ACCESS DOORS IN FINISHED CONSTRUCTION

- A. Furnish access doors as required for operation and maintenance of concealed equipment and coordinate their delivery with the installing trade.
- B. Coordinate and prepare a location, size and function schedule of access doors required and deliver to the General Contractor and the Architect for review.
- C. Doors shall be of a size required for operating and repacking valves, and shall be as manufactured by Karp Associates, Nystrom Inc. or Mifab.
- D. Unless otherwise indicated, minimum size to be 18" x 18".
- E. Furnish color coded buttons or tabs to indicate location of valves or other equipment located above removable type ceilings where access doors are not required.

1.16 SYSTEMS IDENTIFICATION

- A. Piping:
 - 1. All exposed fire protection piping shall be finish painted red in color unless otherwise directed.
 - 2. All piping, exposed or concealed, shall be identified as to its service in accordance with OSHA and ANSI Standards by one of the following methods:
 - a. Installation of manufactured adhesive band type identification markers, similar to "Quick-Label" by W.H. Brady Company.
 - 3. Piping identification markings shall be installed as follows:
 - a. In each room.
 - b. All valve locations.

- c. At shaft walls.
 - d. Every 40 feet on continuous runs.
- B. Valves:
- 1. Valves shall be identified by tag system utilizing brass tags at 2-inch minimum diameter and attached to the valves using brass chain.
 - a. The new valve tag identification numbers shall be permanently added to all existing valve tag charts.
 - 2. The service and function of all fire protection valves shall be identified at the valve by signs, similar to Potter Roemer Series 6300, attached to the valves by brass chains.
- C. Equipment:
- 1. Identify all controls such as motor starters not in motor control centers, float switches, and alarms.

1.17 OPERATING & MAINTENANCE INSTRUCTION

- A. Prepare an operating and maintenance instruction manual which includes the following:
- 1. Alphabetical list of all system components, with the name, address, and 24-hour phone number of the company responsible for servicing each item during the first year of operation.
 - 2. Operating instructions for complete system, including:
 - a. Normal starting, operating, and shut-down.
 - b. Emergency procedures for fire or failure of major equipment.
 - c. Summer and winter special procedures.
 - d. Day and night special procedures.
 - 3. Maintenance instructions, including:
 - a. Valve tag list and equipment tag list.
 - b. Proper lubricants and lubricating instructions for each piece of equipment, and date when lubricated.
 - c. Required cleaning, replacement and/or adjustment schedule.
 - 4. Manufacturer's data on each piece of equipment, including:
 - a. Installation instructions.
 - b. Drawings and specifications.
 - c. Parts list, including recommended items to be stocked.
 - d. Complete wiring and temperature control diagrams.
 - e. Marked or revised prints locating all concealed parts and all variations from the original system design.
 - f. Test and inspection certificates.
 - 5. Specific equipment data including, but not limited to, the following:
 - a. Piping.
 - b. Valves.
 - c. Accessories.
 - d. Sprinkler heads.
 - e. Tamper switches.
 - f. Flow switches.
 - g. Electric wiring.

- h. Controllers.
 - 6. For Automatic Control System
 - a. Drawings and description of system controlled.
 - b. Sequence of operation for each system.
 - c. Data on components.
 - d. Wiring and piping, schematic any layout, for panels and panelboards.
 - e. System operating manual, including set points.
 - B. Provide instruction of operating personnel.
 - 1. Instruct Owner's operating personnel in proper starting sequences, operation, shutdown, and maintenance procedures, including normal and emergency procedures.
 - 2. Instruction to be by personnel skilled in operation of equipment. Instructions for major equipment to be by equipment manufacturers' representatives.
 - 3. Make arrangements to give instructions by system and not by building areas.
 - 4. Provide five (5) instruction sessions not to exceed six (6) hours each.
 - 5. Instructions on automatic controls to be by manufacturer's representative.
 - C. Submittals.
 - 1. Shop Drawings: Submit three copies for review prior to final issuance.
 - 2. Provide 6 copies of each operation and maintenance manual.
 - a. Manuals to be 8-1/2" x 11" size in hard-back, 3-ring loose-leaf binders. Use more than one volume if required. Do not overfill binders.
 - b. Manuals to be completed and delivered to the Engineer for approval at least 20 days prior to instruction of operating personnel.
 - 3. Prepare separate manuals for the fire protection systems.
- 1.18 TOOLS FOR OPERATION, ADJUSTMENT AND MAINTENANCE
- A. Deliver to Owner's representative all special tools needed for proper operation, adjustment and maintenance of equipment.
- 1.19 RECORD DRAWINGS
- A. The contractor shall maintain a complete set of "Record Drawings" reflecting an accurate dimensional record of all work. These drawings shall be marked up to show the precise location of concealed work and equipment, including concealed piping and valves and all changes and deviations in the plumbing work from that shown on the contract drawings. This requirement shall not be construed as authorization for the contractor to make changes in the layout or work without written definite instruction from the Architect or Engineer.
 - B. Record dimensions shall clearly and accurately delineate the work as installed; location shall be suitably identified by at least two dimensions to permanent structures.
 - C. The contractor shall stamp all "Record Drawings" and certify for correctness by signing and dating them.
 - D. Record drawings submitted to Owner shall consist of 1 set of mylars and 1 set of compact disk's (CD's) with all work provided on Autocad 2000 format.
 - E. Prior to final acceptance, contractor shall submit certified "Record Drawings" to the Architect/Engineer for review and make changes, corrections or additions as noted

by Architect/Engineer. After this review, the drawing shall be delivered to the Owner.

PART 2 - PRODUCTS

NOT USED.

PART 3 - EXECUTION

NOT USED.

END OF SECTION

Section 21 05 00

COMMON WORK RESULTS FOR FIRE SUPPRESSION

PART 1 - GENERAL

1.1 RELATED DOCUMENTS

- A. Drawings and general provisions of the Contract, including General and Supplementary Conditions and Division 01 Specification Sections, apply to this Section.
- B. Section 01 81 13 "Sustainable Design Requirements – LEED v4 for Building Design & Construction – New Construction" for sustainable design requirements and detailed sustainable design submittal requirements.
- C. Section 01 74 19 "Construction and Demolition Waste Management and Disposal" for disposal of construction, demolition and packaging waste disposal requirements.

1.2 SUMMARY

- A. This Section includes the following:
 - 1. Piping materials and installation instructions common to most piping systems.
 - 2. Mechanical sleeve seals.
 - 3. Sleeves.
 - 4. Escutcheons.
 - 5. Equipment installation requirements common to equipment sections.
 - 6. Painting and finishing.
 - 7. Supports and anchorages.
- B. Sustainable Building Requirements:
 - 1. The Owner requires the Contractor to implement practices and procedures to meet the project's environmental performance goals, which include achieving LEED version 4 **Certified** level Certification. Specific project goals that may impact this area of work include: use of recycled-content materials; use of locally-manufactured materials; use of low-emitting materials; construction waste recycling; and the implementation of a construction indoor air quality management plan. The Contractor shall ensure that the requirements related to these goals, as defined in the Articles below, are implemented to the fullest extent. Substitutions, or other changes to the work proposed by the Contractor or their Subcontractors, shall not be allowed if such changes compromise the aforementioned environmental goals and LEED certification.

1.3 DEFINITIONS

- A. Finished Spaces: Spaces other than mechanical and electrical equipment rooms, furred spaces, pipe chases, unheated spaces immediately below roof, spaces above ceilings, unexcavated spaces, crawlspaces, and tunnels.
- B. Exposed, Interior Installations: Exposed to view indoors. Examples include finished occupied spaces and mechanical equipment rooms.

- C. Exposed, Exterior Installations: Exposed to view outdoors or subject to outdoor ambient temperatures and weather conditions. Examples include rooftop locations.
- D. Concealed, Interior Installations: Concealed from view and protected from physical contact by building occupants. Examples include above ceilings and in chases.
- E. Concealed, Exterior Installations: Concealed from view and protected from weather conditions and physical contact by building occupants but subject to outdoor ambient temperatures. Examples include installations within unheated shelters.
- F. The following are industry abbreviations for rubber materials:
 - 1. EPDM: Ethylene-propylene-diene terpolymer rubber.
 - 2. NBR: Acrylonitrile-butadiene rubber.

1.4 SUBMITTALS

- A. Product Data: For the following:
 - 1. Mechanical sleeve seals.
 - 2. Escutcheons.
- B. Welding certificates.

1.5 QUALITY ASSURANCE

- A. Steel Support Welding: Qualify processes and operators according to AWS D1.1, "Structural Welding Code--Steel."
- B. Steel Pipe Welding: Qualify processes and operators according to ASME Boiler and Pressure Vessel Code: Section IX, "Welding and Brazing Qualifications."
 - 1. Comply with provisions in ASME B31 Series, "Code for Pressure Piping."
 - 2. Certify that each welder has passed AWS qualification tests for welding processes involved and that certification is current.
- C. Electrical Characteristics for Fire-Suppression Equipment: Equipment of higher electrical characteristics may be furnished provided such proposed equipment is approved in writing and connecting electrical services, circuit breakers, and conduit sizes are appropriately modified. If minimum energy ratings or efficiencies are specified, equipment shall comply with requirements.

1.6 DELIVERY, STORAGE, AND HANDLING

- A. Deliver pipes and tubes with factory-applied end caps. Maintain end caps through shipping, storage, and handling to prevent pipe end damage and to prevent entrance of dirt, debris, and moisture.
- B. Store plastic pipes protected from direct sunlight. Support to prevent sagging and bending.

1.7 COORDINATION

- A. Arrange for pipe spaces, chases, slots, and openings in building structure during progress of construction, to allow for fire-suppression installations.
- B. Coordinate installation of required supporting devices and set sleeves in poured-in-place concrete and other structural components as they are constructed.

- C. Coordinate requirements for access panels and doors for fire-suppression items requiring access that are concealed behind finished surfaces. Access panels and doors are specified in Division 08 Section "Access Doors and Frames."

PART 2 - PRODUCTS

2.1 MANUFACTURERS

- A. In other Part 2 articles where subparagraph titles below introduce lists, the following requirements apply for product selection:
 - 1. Manufacturers: Subject to compliance with requirements, provide products by the manufacturers specified.

2.2 PIPE, TUBE, AND FITTINGS

- A. Refer to individual Division 21 piping Sections for pipe, tube, and fitting materials and joining methods.
- B. Pipe Threads: ASME B1.20.1 for factory-threaded pipe and pipe fittings.

2.3 JOINING MATERIALS

- A. Refer to individual Division 21 piping Sections for special joining materials not listed below.
- B. Pipe-Flange Gasket Materials: Suitable for chemical and thermal conditions of piping system contents.
 - 1. ASME B16.21, nonmetallic, flat, asbestos-free, 1/8-inch (3.2-mm) maximum thickness unless thickness or specific material is indicated.
 - a. Full-Face Type: For flat-face, Class 125, cast-iron and cast-bronze flanges.
 - b. Narrow-Face Type: For raised-face, Class 250, cast-iron and steel flanges.
 - 2. AWWA C110, rubber, flat face, 1/8 inch (3.2 mm) thick, unless otherwise indicated; and full-face or ring type, unless otherwise indicated.
- C. Flange Bolts and Nuts: ASME B18.2.1, carbon steel, unless otherwise indicated.
- D. Solder Filler Metals: ASTM B 32, lead-free alloys. Include water-flushable flux according to ASTM B 813.
- E. Brazing Filler Metals: AWS A5.8, BCuP Series, copper-phosphorus alloys for general-duty brazing, unless otherwise indicated; and AWS A5.8, BAg1, silver alloy for refrigerant piping, unless otherwise indicated.
- F. Welding Filler Metals: Comply with AWS D10.12 for welding materials appropriate for wall thickness and chemical analysis of steel pipe being welded.

2.4 MECHANICAL SLEEVE SEALS

- A. Description: Modular sealing element unit, designed for field assembly, to fill annular space between pipe and sleeve.
 - 1. Manufacturers:
 - a. Thunderline

- b. Calpico, Inc.
- c. Metraflex Co.
- 2. Sealing Elements: EPD Minterlocking links shaped to fit surface of pipe. Include type and number required for pipe material and size of pipe.
- 3. Pressure Plates: Plastic. Include two for each sealing element.
- 4. Connecting Bolts and Nuts: Carbon steel with corrosion-resistant coating of length required to secure pressure plates to sealing elements. Include one for each sealing element.

2.5 SLEEVES

- A. Galvanized-Steel Sheet: 0.0239-inch (0.6-mm) minimum thickness; round tube closed with welded longitudinal joint.
- B. Steel Pipe: ASTM A 53, Type E, Grade B, Schedule 40, galvanized, plain ends.
- C. Cast Iron: Cast or fabricated "wall pipe" equivalent to ductile-iron pressure pipe, with plain ends and integral waterstop, unless otherwise indicated.
- D. Stack Sleeve Fittings: Manufactured, cast-iron sleeve with integral clamping flange. Include clamping ring and bolts and nuts for membrane flashing.
 - 1. Underdeck Clamp: Clamping ring with set screws.
- E. Molded PE: Reusable, PE, tapered-cup shaped, and smooth-outer surface with nailing flange for attaching to wooden forms.

2.6 ESCUTCHEONS

- A. Description: Manufactured wall and ceiling escutcheons and floor plates, with an ID to closely fit around pipe, tube, and insulation of insulated piping and an OD that completely covers opening.
- B. One-Piece, Cast-Brass Type: With set screw.
 - 1. Finish: Polished chrome-plated .
- C. Split-Casting, Cast-Brass Type: With concealed hinge and set screw.
 - 1. Finish: Polished chrome-plated .
- D. One-Piece, Floor-Plate Type: Cast-iron floor plate.
- E. Split-Casting, Floor-Plate Type: Cast brass with concealed hinge and set screw.

PART 3 - EXECUTION

3.1 PIPING SYSTEMS - COMMON REQUIREMENTS

- A. Install piping according to the following requirements and Division 21 Sections specifying piping systems.
- B. Drawing plans, schematics, and diagrams indicate general location and arrangement of piping systems. Indicated locations and arrangements were used to size pipe and calculate friction loss, expansion, pump sizing, and other design considerations. Install piping as indicated unless deviations to layout are approved on Coordination Drawings.

- C. Install piping in concealed locations, unless otherwise indicated and except in equipment rooms and service areas.
- D. Install piping indicated to be exposed and piping in equipment rooms and service areas at right angles or parallel to building walls. Diagonal runs are prohibited unless specifically indicated otherwise.
- E. Install piping above accessible ceilings to allow sufficient space for ceiling panel removal.
- F. Install piping to permit valve servicing.
- G. Install piping at indicated slopes or as required to facilitate positive drainage of piping.
- H. Install piping free of sags and bends.
- I. Install fittings for changes in direction and branch connections.
- J. Install piping to allow application of insulation.
- K. Select system components with pressure rating equal to or greater than system operating pressure.
- L. Install escutcheons for penetrations of walls, ceilings, and floors according to the following:
 - 1. New Piping:
 - a. Piping with Fitting or Sleeve Protruding from Wall: One-piece, deep-pattern type.
 - b. Insulated Piping: One-piece, stamped-steel type with spring clips.
 - c. Bare Piping at Wall and Floor Penetrations in Finished Spaces: One-piece, stamped-steel type.
 - d. Bare Piping at Ceiling Penetrations in Finished Spaces: One-piece , cast-brass type with polished chrome-plated finish.
 - e. Bare Piping in Unfinished Service Spaces: One-piece, cast-brass type with polished chrome-plated finish.
 - f. Bare Piping in Equipment Rooms: One-piece, cast-brass type.
 - g. Bare Piping at Floor Penetrations in Equipment Rooms: One-piece, floor-plate type.
- M. Sleeves are not required for core-drilled holes.
- N. Permanent sleeves are not required for holes formed by removable PE sleeves.
- O. Install sleeves for pipes passing through concrete and masonry walls and concrete floor and roof slabs.
- P. Install sleeves for pipes passing through concrete and masonry walls, gypsum-board partitions, and concrete floor and roof slabs.
 - 1. Cut sleeves to length for mounting flush with both surfaces.
 - a. Exception: Extend sleeves installed in floors of mechanical equipment areas or other wet areas 2 inches (50 mm) above finished floor level. Extend cast-iron sleeve fittings below floor slab as required to secure clamping ring if ring is specified.
 - 2. Install sleeves in new walls and slabs as new walls and slabs are constructed.
 - 3. Install sleeves that are large enough to provide 1/4-inch (6.4-mm) annular clear space between sleeve and pipe or pipe insulation. Use the following sleeve materials:
 - a. SteelPipe Sleeves: For pipes smaller than NPS 6 (DN 150).

- b. Steel Sheet Sleeves: For pipes NPS 6 (DN 150) and larger, penetrating gypsum-board partitions.
 - c. Stack Sleeve Fittings: For pipes penetrating floors with membrane waterproofing. Secure flashing between clamping flanges. Install section of cast-iron soil pipe to extend sleeve to 2 inches (50 mm) above finished floor level. Refer to Division 07 Section "Sheet Metal Flashing and Trim" for flashing.
 - 1) Seal space outside of sleeve fittings with grout.
 - 4. Except for underground wall penetrations, seal annular space between sleeve and pipe or pipe insulation, using joint sealants appropriate for size, depth, and location of joint. Refer to Division 07 Section "Joint Sealants" for materials and installation.
- Q. Aboveground, Exterior-Wall Pipe Penetrations: Seal penetrations using sleeves and mechanical sleeve seals. Select sleeve size to allow for 1-inch (25-mm) annular clear space between pipe and sleeve for installing mechanical sleeve seals.
- 1. Install steel pipe for sleeves smaller than 6 inches (150 mm) in diameter.
 - 2. Install cast-iron "wall pipes" for sleeves 6 inches (150 mm) and larger in diameter.
 - 3. Mechanical Sleeve Seal Installation: Select type and number of sealing elements required for pipe material and size. Position pipe in center of sleeve. Assemble mechanical sleeve seals and install in annular space between pipe and sleeve. Tighten bolts against pressure plates that cause sealing elements to expand and make watertight seal.
- R. Fire-Barrier Penetrations: Maintain indicated fire rating of walls, partitions, ceilings, and floors at pipe penetrations. Seal pipe penetrations with firestop materials. Refer to Division 07 Section "Penetration Firestopping" for materials.
- S. Verify final equipment locations for roughing-in.
- T. Refer to equipment specifications in other Sections of these Specifications for roughing-in requirements.
- ### 3.2 PIPING JOINT CONSTRUCTION
- A. Join pipe and fittings according to the following requirements and Division 21 Sections specifying piping systems.
 - B. Ream ends of pipes and tubes and remove burrs. Bevel plain ends of steel pipe.
 - C. Remove scale, slag, dirt, and debris from inside and outside of pipe and fittings before assembly.
 - D. Soldered Joints: Apply ASTM B 813, water-flushable flux, unless otherwise indicated, to tube end. Construct joints according to ASTM B 828 or CDA's "Copper Tube Handbook," using lead-free solder alloy complying with ASTM B 32.
 - E. Brazed Joints: Construct joints according to AWS's "Brazing Handbook," "Pipe and Tube" Chapter, using copper-phosphorus brazing filler metal complying with AWS A5.8.
 - F. Threaded Joints: Thread pipe with tapered pipe threads according to ASME B1.20.1. Cut threads full and clean using sharp dies. Ream threaded pipe ends to remove burrs and restore full ID. Join pipe fittings and valves as follows:
 - 1. Apply appropriate tape or thread compound to external pipe threads unless dry seal threading is specified.

2. Damaged Threads: Do not use pipe or pipe fittings with threads that are corroded or damaged. Do not use pipe sections that have cracked or open welds.
 - G. Welded Joints: Construct joints according to AWS D10.12, using qualified processes and welding operators according to Part 1 "Quality Assurance" Article.
 - H. Flanged Joints: Select appropriate gasket material, size, type, and thickness for service application. Install gasket concentrically positioned. Use suitable lubricants on bolt threads.
- 3.3 PAINTING
- A. Painting of fire-suppression systems, equipment, and components is specified in Division 09 Sections "Interior Painting" and "Exterior Painting."
 - B. Damage and Touchup: Repair marred and damaged factory-painted finishes with materials and procedures to match original factory finish.
- 3.4 ERECTION OF METAL SUPPORTS AND ANCHORAGES
- A. Refer to Division 05 Section "Metal Fabrications" for structural steel.
 - B. Cut, fit, and place miscellaneous metal supports accurately in location, alignment, and elevation to support and anchor fire-suppression materials and equipment.
 - C. Field Welding: Comply with AWS D1.1.

END OF SECTION

This page is intentionally left blank.

Section 21 10 00

WATER-BASED FIRE-SUPPRESSION SYSTEMS

PART 1 - GENERAL

1.1 RELATED DOCUMENTS

- A. Drawings and general provisions of the Contract, including General and Supplementary Conditions and Division 01 Specification Sections, apply to this Section.
- B. Section 01 81 13 "Sustainable Design Requirements – LEED v4 for Building Design & Construction – New Construction" for sustainable design requirements and detailed sustainable design submittal requirements.
- C. Section 01 74 19 "Construction and Demolition Waste Management and Disposal" for disposal of construction, demolition and packaging waste disposal requirements.

1.2 SUMMARY

- A. This Section includes the following fire-suppression piping inside the building:
 - 1. Wet-pipe sprinkler systems.
- B. Related Sections include the following:
 - 1. Division 10 Section "Fire Extinguisher Cabinets" and "Fire Extinguishers" for cabinets and fire extinguishers.
 - 2. Division 28 Section "Fire Detection and Alarm" for alarm devices not specified in this Section.
- C. Sustainable Building Requirements:
 - 1. The Owner requires the Contractor to implement practices and procedures to meet the project's environmental performance goals, which include achieving LEED version 4 **Certified** level Certification. Specific project goals that may impact this area of work include: use of recycled-content materials; use of locally-manufactured materials; use of low-emitting materials; construction waste recycling; and the implementation of a construction indoor air quality management plan. The Contractor shall ensure that the requirements related to these goals, as defined in the Articles below, are implemented to the fullest extent. Substitutions, or other changes to the work proposed by the Contractor or their Subcontractors, shall not be allowed if such changes compromise the aforementioned environmental goals and LEED certification.

1.3 DEFINITIONS

- A. CR: Chlorosulfonated polyethylene synthetic rubber.
- B. High-Pressure Piping System: Fire-suppression piping system designed to operate at working pressure higher than standard 175 psig (1200 kPa).
- C. PE: Polyethylene plastic.

- D. Underground Service-Entrance Piping: Underground service piping below the building.

1.4 SYSTEM DESCRIPTIONS

- A. Combined Standpipe and Sprinkler System: Fire-suppression system with both standpipe and sprinkler systems. Sprinkler system is supplied from standpipe system.
- B. Wet-Pipe Sprinkler System: Automatic sprinklers are attached to piping containing water and that is connected to water supply. Water discharges immediately from sprinklers when they are opened. Sprinklers open when heat melts fusible link or destroys frangible device. Hose connections are included if indicated.

1.5 PERFORMANCE REQUIREMENTS

- A. Standard Piping System Component Working Pressure: Listed for at least 175 psig (1200 kPa).
- B. High-Pressure Piping System Component Working Pressure: Listed for 300 psig (2070 kPa).
- C. Fire-suppression standpipe system design shall be approved by authorities having jurisdiction.
 - 1. Minimum residual pressure at each hose-connection outlet is the following:
 - a. NPS 2-1/2 (DN 65) Hose Connections: 100 psig (690 kPa).
 - 2. Unless otherwise indicated, the following is maximum residual pressure at required flow at each hose-connection outlet:
 - a. NPS 2-1/2 (DN 65) Hose Connections: 175 psig (1200 kPa).
- D. Fire-suppression sprinkler system design shall be approved by authorities having jurisdiction.
 - 1. Margin of Safety for Available Water Flow and Pressure: 10 percent, including losses through water-service piping, valves, and backflow preventers.
 - 2. Sprinkler Occupancy Hazard Classifications:
 - a. Building Service Areas: Ordinary Hazard, Group 1.
 - b. Electrical Equipment Rooms: Ordinary Hazard, Group 1.
 - c. General Storage Areas: Ordinary Hazard, Group 1.
 - d. Mechanical Equipment Rooms: Ordinary Hazard, Group 1.
 - e. Office and Public Areas: Light Hazard.
 - f. Patient Areas: Light Hazard
 - 3. Minimum Density for Automatic-Sprinkler Piping Design:
 - a. Light-Hazard Occupancy: 0.10 gpm over 1500-sq. ft. (6.3 mL/s over 139-sq. m) area.
 - b. Ordinary-Hazard, Group 1 Occupancy: 0.15 gpm over 2000-sq. ft. (9.5 mL/s over 139-sq. m) area.
 - c. Ordinary-Hazard, Group 2 Occupancy: 0.20 gpm over 2000-sq. ft. (12.6 mL/s over 139-sq. m) area.
 - d. Extra-Hazard, Group 1 Occupancy: 0.30 gpm over 2500-sq. ft. (18.9 mL/s over 232-sq. m) area.
 - e. Extra-Hazard, Group 2 Occupancy: 0.40 gpm over 2500-sq. ft. (25.2 mL/s over 232-sq. m) area.

- f. Special Occupancy Hazard: As determined by authorities having jurisdiction.
- 4. Maximum Protection Area per Sprinkler:
 - a. Office Spaces and Patient Areas: 225 sq. ft. (20.9 sq. m).
 - b. Storage Areas: 130 sq. ft. (12.1 sq. m).
 - c. Mechanical Equipment Rooms: 130 sq. ft. (12.1 sq. m).
 - d. Electrical Equipment Rooms: 130 sq. ft. (12.1 sq. m).
 - e. Other Areas: According to NFPA 13 recommendations, unless otherwise indicated.
- 5. Total Combined Hose-Stream Demand Requirement: According to NFPA 13, unless otherwise indicated:
 - a. Light-Hazard Occupancies: 100 gpm (6.3 L/s) for 30 minutes.
 - b. Ordinary-Hazard Occupancies: 250 gpm (15.75 L/s) for 60 to 90 minutes.
 - c. Extra-Hazard Occupancies: 500 gpm (31.5 L/s) for 90 to 120 minutes.
- E. Seismic Performance: Fire-suppression piping shall be capable of withstanding the effects of earthquake motions determined according to NFPA 13 and IBC 2006.

1.6 SUBMITTALS

- A. Product Data: For the following:
 - 1. Piping materials, including sprinkler specialty fittings.
 - 2. Pipe hangers and supports, including seismic restraints.
 - 3. Valves, including listed fire-protection valves, unlisted general-duty valves, and specialty valves and trim.
 - 4. Sprinklers, escutcheons, and guards. Include sprinkler flow characteristics, mounting, finish, and other pertinent data.
 - 5. Hose connections, including size, type, and finish.
 - 6. Hose stations, including size, type, and finish of hose connections; type and length of fire hoses; finish of fire hose couplings; type, material, and finish of nozzles; and finish of rack.
 - 7. Fire department connections, including type; number, size, and arrangement of inlets; caps and chains; size and direction of outlet; escutcheon and marking; and finish.
 - 8. Alarm devices, including electrical data.
- B. Shop Drawings: Diagram power, signal, and control wiring.
- C. Fire-hydrant flow test report.
- D. Approved Sprinkler Piping Drawings: Working plans, prepared according to NFPA 13, that have been approved by authorities having jurisdiction, including hydraulic calculations, if applicable.
- E. Field Test Reports and Certificates: Indicate and interpret test results for compliance with performance requirements and as described in NFPA 13 and NFPA 14. Include "Contractor's Material and Test Certificate for Aboveground Piping" and "Contractor's Material and Test Certificate for Underground Piping."
- F. Welding certificates.
- G. Field quality-control test reports.

- H. Operation and Maintenance Data: For standpipe and sprinkler specialties to include in emergency, operation, and maintenance manuals.

1.7 QUALITY ASSURANCE

- A. Installer Qualifications:
 - 1. Installer's responsibilities include designing, fabricating, and installing fire-suppression systems and providing professional engineering services needed to assume engineering responsibility. Base calculations on results of fire-hydrant flow test.
 - a. Engineering Responsibility: Preparation of working plans, calculations, and field test reports by a qualified professional engineer.
- B. Welding: Qualify processes and operators according to ASME Boiler and Pressure Vessel Code: Section IX.
- C. NFPA Standards: Fire-suppression-system equipment, specialties, accessories, installation, and testing shall comply with the following:
 - 1. NFPA 13, "Installation of Sprinkler Systems."
 - 2. NFPA 14, "Installation of Standpipe, Private Hydrant, and Hose Systems."
 - 3. NFPA 24, "Installation of Private Fire Service Mains and Their Appurtenances."

1.8 COORDINATION

- A. Coordinate layout and installation of sprinklers with other construction that penetrates ceilings, including light fixtures, HVAC equipment, and partition assemblies.

1.9 EXTRA MATERIALS

- A. Furnish extra materials described below that match products installed and that are packaged with protective covering for storage and identified with labels describing contents.
 - 1. Sprinkler Cabinets: Finished, wall-mounting, steel cabinet with hinged cover, with space for minimum of six spare sprinklers plus sprinkler wrench. Include number of sprinklers required by NFPA 13 and sprinkler wrench. Include separate cabinet with sprinklers and wrench for each type of sprinkler on Project.

PART 2 - PRODUCTS

2.1 MANUFACTURERS

- A. In other Part 2 articles where titles below introduce lists, the following requirements apply to product selection:
 - 1. Manufacturers: Subject to compliance with requirements, provide products by one of the manufacturers specified.

2.2 STEEL PIPE AND FITTINGS

- A. Threaded-End, Standard-Weight Steel Pipe: ASTM A 53/A 53M, ASTM A 135, or ASTM A 795, hot-dip galvanized where indicated and with factory- or field-formed threaded ends.
 - 1. Cast-Iron Threaded Flanges: ASME B16.1.
 - 2. Malleable-Iron Threaded Fittings: ASME B16.3.
 - 3. Gray-Iron Threaded Fittings: ASME B16.4.
 - 4. Steel Threaded Pipe Nipples: ASTM A 733, made of ASTM A 53/A 53M or ASTM A 106, Schedule 40, seamless steel pipe hot-dip galvanized where indicated. Include ends matching joining method.
 - 5. Steel Threaded Couplings: ASTM A 865 hot-dip galvanized-steel pipe where indicated.
- B. Plain-End, Standard-Weight Steel Pipe: ASTM A 53/A 53M, ASTM A 135, or ASTM A 795.
 - 1. Steel Welding Fittings: ASTM A 234/A 234M, and ASME B16.9 or ASME B16.11.
 - 2. Steel Flanges and Flanged Fittings: ASME B16.5.
- C. Grooved-End, Standard-Weight Steel Pipe: ASTM A 53/A 53M, ASTM A 135, or ASTM A 795, hot-dip galvanized where indicated and with factory- or field-formed, roll-grooved ends.
 - 1. Grooved-Joint Piping Systems:
 - a. Manufacturers:
 - 1) National Fittings, Inc.
 - 2) Victaulic Co. of America.
 - 3) Ward Manufacturing.
 - b. Grooved-End Fittings: UL-listed, ASTM A 536, ductile-iron casting with OD matching steel-pipe OD.
 - c. Grooved-End-Pipe Couplings: UL 213 and AWWA C606, rigid pattern, unless otherwise indicated; gasketed fitting matching steel-pipe OD. Include ductile-iron housing with keys matching steel-pipe and fitting grooves, prelubricated rubber gasket listed for use with housing, and steel bolts and nuts.

2.3 AFFF FOAM/WATER FIRE PROTECTION SYSTEM

- A. Overview
 - 1. Sprinkler system shall be a pilot pressure regulating AFFF foam system designed to provide adequately proportioned foam water solution at listed water flows past proportioning device. System shall be installed in accordance with NFPA 13, Standard for Installation of Sprinkler Systems, NFPA 409, Standard on Aircraft Hangars, NFPA 418, Standard for Heliport, Air Force Engineering Technical Letter 02-15: Fire Protection Engineering Criteria - New Aircraft Facilities and all other applicable codes or requirements.

B. System Devices

1. System Design

- a. The system shall be capable of providing a density of .10 over entire rooftop landing pad. The duration of foam discharge for the fixed discharge outlet system shall be 10 minutes.

2. Pilot Pressure Regulating Proportioning System

- a. Pilot Pressure Regulating proportioning system shall be entirely automatic. The concentrate control system shall utilize a foam bladder tank. This system consists of a standard deluge sprinkler system, using a Viking flow control valve with pressure regulating flow control trim, a release module for the supplemental detection system, an In-Line Balanced Pressure Proportioner, a hydraulically actuated Viking Halar® coated concentrate control valve, and foam concentrate UL listed or FM approved for use with The Viking System.

- b. Water supply pressure to the bladder tank must be provided from a down stream source, after the pilot pressure regulating deluge valve, preferably between the discharge outlet of the flow control valve and the In-Line Balanced Pressure Proportioner. The listed pressure differential for the pressure regulating trim is 20 PSIG (138 kPa). The inlet pressure at the desired flow rate to the pressure regulating deluge system must be 20 psi higher than the desired pressure on the discharge side of the deluge valve.

- c. In order to obtain the pressure differential between foam/water solution and supply water pressure, the pilot pressure regulating valve on the pressure regulating deluge trim must be adjusted to reduce the water pressure past the discharge side of the flow control valve. For best results the pilot pressure regulating deluge valve should be set using the downstream pressure gauge of the pilot pressure regulating deluge valve and the water pressure gauge. For existing sprinkler systems which are restricted in flow and pressure capacity this system should not be used without supplementing the available supply pressure.

3. Supplemental Detection System

- a. A supplemental detection system shall be provided for all preaction systems.

- b. Per NFPA 409, actuation systems shall be provided with complete circuit supervision and be installed per NFPA 72.

- 1) Detectors shall be rate of rise, fixed temperature or rate compensation.

- c. Per ETL 02-15

4. Deluge Valve Release Control Panel

- a. If preaction system is to utilize electric release, the system release panel shall be capable of a dual system split release, dual system combined release, single system cross zone release, single system two zone release. Release panel shall be equipped with a local tone alarm to annunciate loss of A/C power, system trouble, circuit trouble and low auxiliary D/C power supply. Release panel shall be capable of supervising trouble and alarm audible alarms. Trouble and alarm audible alarms shall be able to be silenced at release panel. Release panel shall be housed in a vented enclosure with ambient temperature compatibility of 32°F to 120°F. Panel enclosure shall be of adequate size to house auxiliary D/C power supply. Auxiliary D/C power supply

- shall consist of (2) 12 volt lead acid batteries of the same ampere hour rating. Actual ampere hour rating to be established by auxiliary D/C power requirement. Release Panel shall be Viking Model VFR400 Release Control Panel. (No Substitutions Allowed)
5. Solenoid Valve
 - a. Flow control valve priming water release device shall be an electrically operated solenoid valve when electric releases are used as the detection system. Solenoid valve shall be constructed of a 1/2" brass body with a stainless steel core tube, core, plugnut and springs. Solenoid valve shall have a maximum working pressure of not less than 175 PSI. Solenoid valve shall be UL listed for its intended use. Solenoid valve shall be listed for use with Viking Model H or J Flow Control Valves. (No Substitutions Allowed)
 6. Pneumatic Actuator
 - a. Preaction systems utilizing pneumatic release detectors shall employ a device between the detection and the operating systems. Such device shall actuate a release series in the deluge valve priming water supply. The actuator of the pneumatic release system shall be UL listed and FM approved for use with the deluge valve installed. Pneumatic Actuator shall be Viking Model H-1. (No Substitutions Allowed)
 7. Foam Bladder Tank
 - a. Provide a low expansion foam bladder tank system for storage of the foam concentrate. The tank shall be stamped as meeting ASME pressure vessel requirements and UL Listed/FM Approved for use with the foam concentrate and proportioning method utilized. Foam bladder tank shall be located as close to the riser as practical and located to allow adequate access for filling and inspection. Connect bladder tank water supply to the system riser at or above the level of the top of the tank and provide a primary relief valve. Foam bladder tank shall be UL listed and FM approved. Bladder tanks shall be Chemguard Horizontal or Vertical Bladder Tanks. (No Substitutions Allowed)
 8. Concentrate Control Valve
 - a. Install a deluge valve utilized as a concentrate control valve between the bladder tank and concentrate controller. The CCV valve shall open automatically when the sprinkler system experiences water flow. The CCV shall be UL Listed or FM Approved for use on fire protection systems and have an operating pressure up to 250 PSI (17 BAR) and utilize a 90° or straight-through pattern type of deluge valve manufactured with a corrosive resistant Halar coating. Concentrate control valve trim shall be compatible and installed following the manufacturer's installation instructions. Halar Coated Concentrate Control Valve shall be Viking Model shall be E-2, E-4, F-2 or J-2. (No Substitutions Allowed)
 9. Foam Concentrate Piping
 - a. Foam concentrate piping shall be compatible with foam concentrate to be used. Foam provider shall be consulted for acceptable materials of construction. Foam concentrate piping shall be designed for the least equivalent feet of pipe run from bladder tank discharge outlet to proportioning device and water supply to bladder tank. Excessive use of elbows and tees shall be avoided. Foam concentrate piping shall be substantially secured and restrained against movement, thrust and

- vibration. Foam concentrate piping shall be protected from excessive heat and freezing temperatures. Foam concentrate piping shall be installed with a fitting such as a grooved coupling or union to be readily removed between proportioning assembly and concentrate control valve.
10. In-line Balanced Proportioner (ILBP)
 - a. In-line balanced proportioner (ILBP) shall be factory assembled and UL Listed/FM Approved with the foam concentrate and as an integral part of the complete system. The device shall be specifically tested for use with Viking Low Flow Foam Systems and include a concentrate controller and an internally balancing spool valve. ILBP shall have a foam inlet pressure at least 15 psi greater than the water inlet pressure up to a maximum foam inlet pressure of 200psi. Sprinkler contractor to install the water pressure sensing line on the system riser at least one pipe diameter below the concentrate controller. In-line Balanced Pressure Proportioner manufacturer to be Chemguard. (No Substitutions Allowed)
 11. Foam Concentrate
 - a. Synthetic Aqueous Film Forming Foam (AFFF) or Alcohol Resistant Aqueous Film Forming Foam (AR-AFFF) shall be utilized. Water-soluble liquids shall be protected with Alcohol resistant type foam concentrate. Foam concentrates shall be UL Listed or FM Approved for the required application as well as for use with proportioning equipment and discharge devices. Stored foam concentrate shall not be a mixture of different types and/or brands and shall be stored in accordance with the manufacturer's guidelines. The AHJ should be consulted to determine reserve foam supply requirements. Foam concentrates shall be Chemguard Synthetic Foam Concentrates. (No Substitutions Allowed)
 12. Alarm Pressure Switch
 - a. Provide an alarm pressure switch to facilitate the transmission of an alarm during waterflow conditions. The switch shall be factory adjusted to operate with a pressure increase of 5-7 psi and waterflow equal to or in excess of the discharge from one sprinkler. The switch shall be cULus Listed/FM Approved for operating pressures up to 250 psi (17 BAR) and capable of being wired for a class A or class B circuit. Housing for the switch shall be NEMA 4 rated incorporating tamper-resistant screws. The alarm pressure switch shall be Potter PS101A or PS102A.
 13. System Overhead Piping
 - a. Overhead sprinkler piping shall be in accordance with materials deemed acceptable by NFPA 13, Standard for the Installation of Sprinkler Systems, NFPA 409, Standard on Aircraft Hangars, NFPA 418, Standard for Heliports and all other applicable building standards.
 14. System Control Valve
 - a. Low Flow Foam system control valve shall consist of a listed indicating type of control valve. Control valve shall be listed for use in fire protection systems. Control valve shall be rated for system working water pressure but in no case shall be listed for pressure less than 175 PSI.
 15. Hangers and Supports
 - a. System piping shall be substantially supported from the building structure. The installation of hangers and supports shall adhere to the

- requirements set forth in NFPA 13, Standard for the Installation of Sprinkler Systems. Materials used in the installation or construction of hangers and supports shall be listed and approved for such application. Hangers or supports not specifically listed for service shall be designed and bear the seal of a professional engineer.
16. Fire Department Connection
 - a. A system fire department connection shall be provided on the system riser in accordance with NFPA 16, Standard for Installation of Foam-Water Sprinkler Systems. Fire department connection shall be of a brass body with an integral clapper assembly to separate flow between inlets. Fire department connection shall be installed in an area accessible for the first response unit; actual fire department location shall be installed and located only after proper coordination with fire officials. Fire department connection shall be UL listed and FM approved for fire protection use.
 17. Drains and Flushing Connections
 - a. System drains shall adhere to the requirements set forth in NFPA 13, Standard for the Installation of Sprinkler Systems. Flushing connections shall be provided where system piping is subject to accumulation of sediments or where periodic flushing is required by the Authority Having Jurisdiction. System auxiliary drains shall be installed so that the drain valve is accessible and labeled as a sprinkler system drain. Drains shall terminate to the exterior of the building where practical. Drains that do terminate to the exterior shall be installed with a 45° elbow directed to a splash block or other permanent erosion limiting material.
 18. Riser Test Connections
 - a. A test connection shall be provided on the system riser with a downstream isolation valve for the purpose of testing foam proportioning. System test header shall be of adequate size for at least a mid-range flow of the proportioning system. System test header shall be installed with a means of draining any trapped sections of discharge piping subject to freezing.
 19. System Supervision
 - a. Control valves larger than 2" in size shall be equipped with UL listed and FM approved supervisory switches. Control valves 2" and smaller shall be sealed in the position of their normal operating condition. Others shall execute the termination of supervisory switch wires. Supervisory switches shall be Potter Electrical Signal Company Control Valve Supervisory Switch.
 20. System Commissioning
 - a. Foam water sprinkler system shall be tested in accordance with NFPA 13, NFPA 409, NFPA 418 and all other applicable codes and jurisdictions. An owner's representative, local fire officials and a representative of the installing contractor shall witness foam proportioning tests. Additional foam concentrate shall be provided for testing by the installing contractor. The installing contractor shall provide maintenance and material safety data sheets (MSDS) to the owner.

2.4 DIELECTRIC FITTINGS

- A. Assembly shall be copper alloy, ferrous, and insulating materials with ends matching piping system.
- B. Dielectric Unions: Factory-fabricated assembly, designed for 250-psig (1725-kPa) minimum working pressure at 180 deg F (82 deg C). Include insulating material that isolates dissimilar materials and ends with inside threads according to ASME B1.20.1.
 - 1. Manufacturers:
 - a. Epco Sales, Inc.
 - b. Watts Industries, Inc.; Water Products Div.
 - c. Zurn Industries, Inc.; Wilkins Div.
- C. Dielectric Flanges: Factory-fabricated companion-flange assembly, for 175-psig (1200-kPa) minimum working-pressure rating as required for piping system.
 - 1. Manufacturers:
 - a. Epco Sales, Inc.
 - b. Watts Industries, Inc.; Water Products Div.
- D. Dielectric Flange Insulation Kits: Components for field assembly shall include CR or phenolic gasket, PE or phenolic bolt sleeves, phenolic washers, and steel backing washers.
 - 1. Manufacturers:
 - a. Calpico, Inc.
 - b. Central Plastics Company.
 - c. Pipeline Seal and Insulator, Inc.

2.5 SPRINKLER SPECIALTY FITTINGS

- A. Sprinkler specialty fittings shall be UL listed or FMG approved, with 175-psig (1200-kPa) minimum working-pressure rating, and made of materials compatible with piping. Sprinkler specialty fittings shall have 300-psig (2070-kPa) working-pressure rating if fittings are components of high-pressure piping system.
- B. Outlet Specialty Fittings:
 - 1. Manufacturers:
 - a. National Fittings, Inc.
 - b. Star Pipe Products; Star Fittings Div.
 - c. Victaulic Co. of America.
 - d. Ward Manufacturing.
 - 2. Mechanical-T and -Cross Fittings: UL 213, ductile-iron housing with gaskets, bolts and nuts, and threaded, locking-lug, or grooved outlets.
- C. Sprinkler Drain and Alarm Test Fittings: Cast- or ductile-iron body; with threaded or locking-lug inlet and outlet, test valve, and orifice and sight glass.
 - 1. Manufacturers:
 - a. Central Sprinkler Corp.
 - b. Fire-End and Croker Corp.
 - c. Viking Corp.
 - d. Victaulic Co. of America.
- D. Sprinkler Inspector's Test Fitting: Cast- or ductile-iron housing with threaded inlet and drain outlet and sight glass.

1. Manufacturers:
 - a. AGF Manufacturing Co.
 - b. G/J Innovations, Inc.

2.6 LISTED FIRE-PROTECTION VALVES

- A. Valves shall be UL listed or FMG approved, with 175-psig (1200 kPa) minimum pressure rating. Valves shall have 300-psig (2070-kPa) pressure rating if valves are components of high-pressure piping system.
- B. Gate Valves with Wall Indicator Posts:
 1. Gate Valves: UL 262, cast-iron body, bronze mounted, with solid disc, nonrising stem, operating nut, and flanged ends.
 2. Indicator Posts: UL 789, horizontal-wall type, cast-iron body, with hand wheel, extension rod, locking device, and cast-iron barrel.
 3. Manufacturers:
 - a. Grinnell Fire Protection.
 - b. McWane, Inc.; Kennedy Valve Div.
 - c. NIBCO.
 - d. Stockham.
- C. Ball Valves: Comply with UL 1091, except with ball instead of disc.
 1. NPS 1-1/2 (DN 40) and Smaller: Bronze body with threaded ends.
 2. NPS 2 and NPS 2-1/2 (DN 50 and DN 65): Bronze body with threaded ends or ductile-iron body with grooved ends.
 3. NPS 3 (DN 80): Ductile-iron body with grooved ends.
 4. Manufacturers:
 - a. NIBCO.
 - b. Milwaukee
 - c. Stockham
 5. NPS 2-1/2 (DN 65) and Larger: Bronze, cast-iron, or ductile-iron body; wafer type or with flanged or grooved ends.
 - a. Manufacturers:
 - 1) McWane, Inc.; Kennedy Valve Div.
 - 2) Mueller Company.
 - 3) NIBCO.
 - 4) Milwaukee
- D. Check Valves NPS 2 (DN 50) and Larger: UL 312, swing type, cast-iron body with flanged or grooved ends.
 1. Manufacturers:
 - a. Crane Co.; Crane Valve Group; Crane Valves.
 - b. Crane Co.; Crane Valve Group; Jenkins Valves.
 - c. Grinnell Fire Protection.
 - d. Hammond Valve.
 - e. McWane, Inc.; Kennedy Valve Div.
 - f. Mueller Company.
 - g. NIBCO.
 - h. Stockham.
- E. Gate Valves: UL 262, OS&Y type.
 1. NPS 2 (DN 50) and Smaller: Bronze body with threaded ends.
 - a. Manufacturers:

- 1) Crane Co.; Crane Valve Group; Crane Valves.
 - 2) Hammond Valve.
 - 3) NIBCO.
 2. NPS 2-1/2 (DN 65) and Larger: Cast-iron body with flanged ends.
 - a. Manufacturers:
 - 1) Crane Co.; Crane Valve Group; Crane Valves.
 - 2) Crane Co.; Crane Valve Group; Jenkins Valves.
 - 3) Milwaukee Valve Company.
 - 4) Mueller Company.
 - 5) NIBCO.
 - F. Indicating Valves: UL 1091, with integral indicating device and ends matching connecting piping.
 1. Indicator: Electrical, 115-V ac, prewired, 2-circuit, supervisory switch Visual.
 2. NPS 2 (DN 50) and Smaller: Ball or butterfly valve with bronze body and threaded ends.
 - a. Manufacturers:
 - 1) Milwaukee Valve Company.
 - 2) NIBCO.
 - 3) Victaulic Co. of America.
 3. NPS 2-1/2 (DN 65) and Larger: Butterfly valve with cast- or ductile-iron body; wafer type or with flanged or grooved ends.
 - a. Manufacturers:
 - 1) McWane, Inc.; Kennedy Valve Div.
 - 2) Milwaukee Valve Company.
 - 3) NIBCO.
- 2.7 UNLISTED GENERAL-DUTY VALVES
- A. Ball Valves NPS 2 (DN 50) and Smaller: MSS SP-110, 2-piece copper-alloy body with chrome-plated brass ball, 600-psig (4140-kPa) minimum CWP rating, blowout-proof stem, and threaded ends.
 - B. Check Valves NPS 2 (DN 50) and Smaller: MSS SP-80, Type 4, Class 125 minimum, swing type with bronze body, nonmetallic disc, and threaded ends.
 - C. Gate Valves NPS 2 (DN 50) and Smaller: MSS SP-80, Type 2, Class 125 minimum, with bronze body, solid wedge, and threaded ends.
 - D. Globe Valves NPS 2 (DN 50) and Smaller: MSS SP-80, Type 2, Class 125 minimum, with bronze body, nonmetallic disc, and threaded ends.
- 2.8 SPECIALTY VALVES
- A. Sprinkler System Control Valves: UL listed or FMG approved, cast- or ductile-iron body with flanged or grooved ends, and 175-psig (1200-kPa) minimum pressure rating. Control valves shall have 300-psig (2070-kPa) pressure rating if valves are components of high-pressure piping system.
 1. Manufacturers:
 - a. Grinnell Fire Protection.
 - b. Reliable Automatic Sprinkler Co., Inc.
 - c. Star Sprinkler Inc.
 - d. Victaulic Co. of America.

- e. Viking Corp.
- 2. Alarm Check Valves: UL 193, designed for horizontal or vertical installation, with bronze grooved seat with O-ring seals, single-hinge pin, and latch design. Include trim sets for bypass, drain, electrical sprinkler alarm switch, pressure gages, and fill-line attachment with strainer.
 - a. Drip Cup Assembly: Pipe drain without valves and separate from main drain piping.

2.9 SPRINKLERS

- A. Sprinklers shall be UL listed or FMG approved, with 175-psig (1200-kPa) minimum pressure rating. Sprinklers shall have 300-psig (2070-kPa) pressure rating if sprinklers are components of high-pressure piping system.
- B. Manufacturers:
 - 1. Grinnell Fire Protection.
 - 2. Reliable Automatic Sprinkler Co., Inc.
 - 3. Star Sprinkler Inc.
 - 4. Viking Corp.
- C. Automatic Sprinklers: With heat-responsive element complying with the following:
 - 1. UL 199, for nonresidential applications.
 - 2. UL 1626, for residential applications.
 - 3. UL 1767, for early-suppression, fast-response applications.
- D. Sprinkler Types and Categories: Nominal 1/2-inch (12.7-mm) orifice for "Ordinary" temperature classification rating, unless otherwise indicated or required by application.
- E. Sprinkler types, features, and options as follows:
 - 1. Concealed ceiling sprinklers, including cover plate.
 - 2. Flush ceiling sprinklers, including escutcheon.
 - 3. Pendent sprinklers.
 - 4. Pendent, dry-type sprinklers.
 - 5. Quick-response sprinklers.
 - 6. Recessed sprinklers, including escutcheon.
 - 7. Sidewall sprinklers.
 - 8. Sidewall, dry-type sprinklers.
 - 9. Upright sprinklers.
- F. Sprinkler Finishes: Chrome plated, bronze, and painted.
- G. Special Coatings: Wax, lead, and corrosion-resistant paint.
- H. Sprinkler Escutcheons: Materials, types, and finishes for the following sprinkler mounting applications. Escutcheons for concealed, flush, and recessed-type sprinklers are specified with sprinklers.
 - 1. Ceiling Mounting: Chrome-plated steel, 2 piece, with 1-inch (25-mm) vertical adjustment.
 - 2. Sidewall Mounting: Chrome-plated steel, one piece, flat.
- I. Sprinkler Guards: Wire-cage type, including fastening device for attaching to sprinkler.

2.10 FIRE DEPARTMENT CONNECTIONS

- A. Manufacturers:
 - 1. Elkhart Brass Mfg. Co., Inc.
 - 2. Fire-End and Croker Corp.
 - 3. Potter-Roemer; Fire-Protection Div.
 - 4. Reliable Automatic Sprinkler Co., Inc.
- B. Wall-Type, Fire Department Connection: UL 405, 300-psig minimum pressure rating; with corrosion-resistant-metal body with brass inlets, brass wall escutcheon plate, brass lugged caps with gaskets and brass chains, and brass lugged swivel connections. Include inlets with threads according to NFPA 1963 and matching local fire department sizes and threads, outlet with pipe threads, extension pipe nipples, check devices or clappers for inlets, and escutcheon plate with marking similar to "AUTO SPKR."
 - 1. Type: Flush, with one (Stor2 Type) inlet and square or rectangular escutcheon plate.
 - 2. Finish: Polished chrome-plated.

2.11 ALARM DEVICES

- A. Alarm-device types shall match piping and equipment connections.
- B. Water-Motor-Operated Alarm: UL 753, mechanical-operation type with pelton-wheel operator with shaft length, bearings, and sleeve to suit wall construction and 10-inch- (250-mm-) diameter, cast-aluminum alarm gong with red-enamel factory finish. Include NPS 3/4 (DN 20) inlet and NPS 1 (DN 25) drain connections.
 - 1. Manufacturers:
 - a. Grinnell Fire Protection.
 - b. Reliable Automatic Sprinkler Co., Inc.
 - c. Star Sprinkler Inc.
 - d. Viking Corp.
- C. Electrically Operated Alarm: UL 464, with 6-inch- (150-mm-) minimum- diameter, vibrating-type, metal alarm bell with red-enamel factory finish and suitable for outdoor use.
 - 1. Manufacturers:
 - a. Potter Electric Signal Company.
 - b. System Sensor.
- D. Water-Flow Indicator: UL 346, electrical-supervision, paddle-operated-type, water-flow detector with 250-psig (1725-kPa) pressure rating and designed for horizontal or vertical installation. Include two single-pole, double-throw circuit switches for isolated alarm and auxiliary contacts, 7 A, 125-V ac and 0.25 A, 24-V dc; complete with factory-set, field-adjustable retard element to prevent false signals and tamperproof cover that sends signal if removed.
 - 1. Manufacturers:
 - a. Grinnell Fire Protection.
 - b. Potter Electric Signal Company.
 - c. System Sensor.
 - d. Viking Corp.

- E. Pressure Switch: UL 753, electrical-supervision-type, water-flow switch with retard feature. Include single-pole, double-throw, normally closed contacts and design that operates on rising pressure and signals water flow.
 - 1. Manufacturers:
 - a. Grinnell Fire Protection.
 - b. Potter Electric Signal Company.
 - c. System Sensor.
 - d. Viking Corp.
- F. Valve Supervisory Switch: UL 753, electrical, single-pole, double-throw switch with normally closed contacts. Include design that signals controlled valve is in other than fully open position.
 - 1. Manufacturers:
 - a. McWane, Inc.; Kennedy Valve Div.
 - b. Potter Electric Signal Company.
 - c. System Sensor.
- G. Indicator-Post Supervisory Switch: UL 753, electrical, single-pole, double-throw switch with normally closed contacts. Include design that signals controlled indicator-post valve is in other than fully open position.
 - 1. Manufacturers:
 - a. Potter Electric Signal Company.
 - b. System Sensor.

2.12 PRESSURE GAGES

- A. Manufacturers:
 - 1. AMETEK, Inc.; U.S. Gauge.
 - 2. Dresser Equipment Group; Instrument Div.
 - 3. Marsh Bellofram.
 - 4. WIKA Instrument Corporation.
- B. Description: UL 393, 3-1/2- to 4-1/2-inch- (90- to 115-mm-) diameter, dial pressure gage with range of 0 to 300 psig (0 to 2070 kPa).
 - 1. Water System Piping: Include caption "WATER" or "AIR/WATER" on dial face.
 - 2. Air System Piping: Include retard feature and caption "AIR" or "AIR/WATER" on dial face.

PART 3 - EXECUTION

3.1 PREPARATION

- A. Perform fire-hydrant flow test according to NFPA 13, NFPA 14, and NFPA 291. Use results for system design calculations required in Part 1 "Quality Assurance" Article.
- B. Report test results promptly and in writing.

3.2 EARTHWORK

- A. Refer to Division 31 Section "Earth Moving" for excavating, trenching, and backfilling.

3.3 EXAMINATION

- A. Examine roughing-in for hose connections and stations to verify actual locations of piping connections before installation.
- B. Examine walls and partitions for suitable thicknesses, fire- and smoke-rated construction, framing for hose-station cabinets, and other conditions where hose connections and stations are to be installed.
- C. Proceed with installation only after unsatisfactory conditions have been corrected.

3.4 PIPING APPLICATIONS, GENERAL

- A. Shop weld pipe joints where welded piping is indicated.
- B. Do not use welded joints for galvanized-steel pipe.
- C. Flanges, flanged fittings, unions, nipples, and transition and special fittings with finish and pressure ratings same as or higher than system's pressure rating may be used in aboveground applications, unless otherwise indicated.
- D. Piping between Fire Department Connections and Check Valves: Galvanized, standard-weight steel pipe with threaded ends; cast- or malleable-iron threaded fittings; and threaded joints.
- E. Underground Service-Entrance Piping: Ductile-iron, mechanical-joint pipe and fittings and restrained joints. Include corrosion-protective encasement.

3.5 SPRINKLER SYSTEM PIPING APPLICATIONS

- A. Standard-Pressure, Wet-Pipe Sprinkler System, 175-psig (1200-kPa) Maximum Working Pressure:
 - 1. NPS 2" and Smaller: Threaded-end, black, standard-weight steel pipe; cast- or malleable-iron threaded fittings; and threaded joints.
 - 2. NPS 2 1/2" and larger: Grooved-end, black, Schedule 10 steel pipe; grooved-end fittings; grooved-end-pipe couplings; and grooved joints.

3.6 VALVE APPLICATIONS

- A. Drawings indicate valve types to be used. Where specific valve types are not indicated, the following requirements apply:
 - 1. Listed Fire-Protection Valves: UL listed and FMG approved for applications where required by NFPA 13 and NFPA 14.
 - a. Shutoff Duty: Use ball, butterfly, or gate valves.
 - 2. Unlisted General-Duty Valves: For applications where UL-listed and FMG-approved valves are not required by NFPA 13 and NFPA 14.
 - a. Shutoff Duty: Use ball, butterfly, or gate valves.
 - b. Throttling Duty: Use ball valves.

3.7 JOINT CONSTRUCTION

- A. Refer to Division 21 Section "Common Work Results for Fire Suppression" for basic piping joint construction.

- B. Threaded Joints: Comply with NFPA 13 for pipe thickness and threads. Do not thread pipe smaller than NPS 8 (DN 200) with wall thickness less than Schedule 40 unless approved by authorities having jurisdiction and threads are checked by a ring gage and comply with ASME B1.20.1.
- C. Grooved Joints: Assemble joints with listed coupling and gasket, lubricant, and bolts.
 - 1. Ductile-Iron Pipe: Radius-cut-groove ends of piping. Use grooved-end fittings and grooved-end-pipe couplings.
 - 2. Steel Pipe: Groove piping as indicated. Use grooved-end fittings and rigid, grooved-end-pipe couplings, unless otherwise indicated.
 - 3. Dry-Pipe Systems: Use fittings and gaskets listed for dry-pipe service.
- D. Dissimilar-Metal Piping Joints: Construct joints using dielectric fittings compatible with both piping materials.
 - 1. NPS 2 (DN 50) and Smaller: Use dielectric unions, couplings, or nipples.
 - 2. NPS 2-1/2 to NPS 4 (DN 65 to DN 100): Use dielectric flanges.
 - 3. NPS 5 (DN 125) and Larger: Use dielectric flange insulation kits.

3.8 SERVICE-ENTRANCE PIPING

- A. Connect fire-suppression piping to water-service piping of size and in location indicated for service entrance to building. Refer to Division 22 Section "Facility Water Distribution Piping" for exterior piping.
- B. Install shutoff valve, backflow preventer, pressure gage, drain, and other accessories indicated at connection to water-service piping. Refer to Division 22 Section "Facility Water Distribution Piping" for backflow preventers.
- C. Install shutoff valve, check valve, pressure gage, and drain at connection to water service.

3.9 PIPING INSTALLATION

- A. Refer to Division 21 Section "Common Work Results for Fire Suppression" for basic piping installation.
- B. Locations and Arrangements: Drawing plans, schematics, and diagrams indicate general location and arrangement of piping. Install piping as indicated, as far as practical.
 - 1. Deviations from approved working plans for piping require written approval from authorities having jurisdiction. File written approval with Architect before deviating from approved working plans.
- C. Install underground ductile-iron service-entrance piping according to NFPA 24 and with restrained joints. Encase piping in corrosion-protective encasement.
- D. Use approved fittings to make changes in direction, branch takeoffs from mains, and reductions in pipe sizes.
- E. Install unions adjacent to each valve in pipes NPS 2 (DN 50) and smaller. Unions are not required on flanged devices or in piping installations using grooved joints.
- F. Install flanges or flange adapters on valves, apparatus, and equipment having NPS 2-1/2 (DN 65) and larger connections.

- G. Install "Inspector's Test Connections" in sprinkler system piping, complete with shutoff valve, sized and located according to NFPA 13.
- H. Install sprinkler piping with drains for complete system drainage.
- I. Install sprinkler zone control valves, test assemblies, and drain risers adjacent to standpipes when sprinkler piping is connected to standpipes.
- J. Install drain valves on standpipes.
- K. Install ball drip valves to drain piping between fire department connections and check valves. Drain to floor drain or outside building.
- L. Install alarm devices in piping systems.
- M. Hangers and Supports: Comply with NFPA 13 for hanger materials.
 - 1. Install standpipe system piping according to NFPA 14.
 - 2. Install sprinkler system piping according to NFPA 13.
- N. Earthquake Protection: Install piping according to NFPA 13 to protect from earthquake damage.
- O. Install pressure gages on riser or feed main, at each sprinkler test connection. Include pressure gages with connection not less than NPS 1/4 (DN 8) and with soft metal seated globe valve, arranged for draining pipe between gage and valve. Install gages to permit removal, and install where they will not be subject to freezing.
- P. Fill wet-pipe sprinkler system piping with water.

3.10 VALVE INSTALLATION

- A. Install listed fire-protection valves, unlisted general-duty valves, specialty valves and trim, controls, and specialties according to NFPA 13 and NFPA 14 and authorities having jurisdiction.
- B. Install listed fire-protection shutoff valves supervised-open, located to control sources of water supply except from fire department connections. Install permanent identification signs indicating portion of system controlled by each valve.
- C. Valves for Wall-Type Fire Hydrants: Install nonrising-stem gate valve in water-supply pipe.
- D. Install check valve in each water-supply connection. Install backflow preventers instead of check valves in potable-water supply sources.
- E. Specialty Valves:
 - 1. Alarm Check Valves: Install in vertical position for proper direction of flow, including bypass check valve and retarding chamber drain-line connection.

3.11 SPRINKLER APPLICATIONS

- A. Drawings indicate sprinkler types to be used. Where specific types are not indicated, use the following sprinkler types:
 - 1. Rooms without Ceilings: Upright sprinklers.
 - 2. Rooms with Suspended Ceilings: Concealed sprinklers.

3. Wall Mounting: Sidewall sprinklers.
4. Spaces Subject to Freezing: Pendent, dry sprinklers.
5. Sprinkler Finishes:
 - a. Upright, Pendent, and Sidewall Sprinklers: Chrome plated in finished spaces exposed to view; rough bronze in unfinished spaces not exposed to view; wax coated where exposed to acids, chemicals, or other corrosive fumes.
 - b. Concealed Sprinklers: Rough brass, with factory-painted cover plate, Color by Architect
 - c. Flush Sprinklers: Bright chrome, with painted white escutcheon.
 - d. Recessed Sprinklers: Bright chrome, with bright chrome escutcheon.

3.12 SPRINKLER INSTALLATION

- A. Install sprinklers in suspended ceilings in center of acoustical ceiling panels and tiles.
- B. Do not install pendent or sidewall, wet-type sprinklers in areas subject to freezing. Use dry-type sprinklers with water supply from heated space.

3.13 FIRE DEPARTMENT CONNECTION INSTALLATION

- A. Install wall-type, fire department connections in vertical wall.
- B. Install ball drip valve at each check valve for fire department connection.

3.14 CONNECTIONS

- A. Drawings indicate general arrangement of piping, fittings, and specialties.
- B. Install piping adjacent to equipment to allow service and maintenance.
- C. Connect water-supply piping to fire-suppression piping. Include backflow preventer between potable-water piping and fire-suppression piping. Refer to Division 22 Section "Domestic Water Piping Specialties" for backflow preventers.
- D. Install ball drip valves at each check valve for fire department connection. Drain to floor drain or outside building.
- E. Connect piping to specialty valves, hose valves, specialties, fire department connections, and accessories.
- F. Electrical Connections: Power wiring is specified in Division 26.
- G. Connect alarm devices to fire alarm.
- H. Ground equipment according to Division 26 Section "Grounding and Bonding for Electrical Systems."
- I. Connect wiring according to Division 26 Section "Low-Voltage Electrical Power Conductors and Cables."
- J. Tighten electrical connectors and terminals according to manufacturer's published torque-tightening values. If manufacturer's torque values are not indicated, use those specified in UL 486A and UL 486B.

3.15 LABELING AND IDENTIFICATION

- A. Install labeling and pipe markers on equipment and piping according to requirements in NFPA 13 and NFPA 14.

3.16 FIELD QUALITY CONTROL

- A. Perform the following field tests and inspections and prepare test reports:
 1. Leak Test: After installation, charge system and test for leaks. Repair leaks and retest until no leaks exist.
 2. Test and adjust controls and safeties. Replace damaged and malfunctioning controls and equipment.
 3. Energize circuits to electrical equipment and devices.
 4. Start and run air compressors.
 5. Flush, test, and inspect sprinkler systems according to NFPA 13, "Systems Acceptance" Chapter.
 6. Flush, test, and inspect standpipe systems according to NFPA 14, "System Acceptance" Chapter.
 7. Coordinate with fire alarm tests. Operate as required.
 8. Coordinate with fire-pump tests. Operate as required.
 9. Verify that equipment hose threads are same as local fire department equipment.
- B. Report test results promptly and in writing to Architect and authorities having jurisdiction.

3.17 CLEANING AND PROTECTION

- A. Clean dirt and debris from sprinklers.
- B. Remove and replace sprinklers with paint other than factory finish.
- C. Protect sprinklers from damage until Substantial Completion.

3.18 DEMONSTRATION

- A. Engage a factory-authorized service representative to train Owner's maintenance personnel to adjust, operate, and maintain specialty valves. Refer to Division 01 Section "Demonstration and Training."

END OF SECTION

TABLE OF CONTENTS

PLUMBING

SECTION NUMBER	SECTION TITLE
22 00 00	PLUMBING GENERAL PROVISIONS
22 05 00	COMMON WORK RESULTS FOR PLUMBING
22 05 13	COMMON MOTOR REQUIREMENTS FOR PLUMBING EQUIPMENT
22 05 16	EXPANSION FITTINGS AND LOOPS FOR PLUMBING PIPING
22 05 19	METERS AND GAGES FOR PLUMBING PIPING
22 05 23	GENERAL-DUTY VALVES FOR PLUMBING PIPING
22 05 29	HANGERS AND SUPPORTS FOR PLUMBING PIPING AND
22 05 53	IDENTIFICATION FOR PLUMBING AND PIPING EQUIPMENT
22 07 00	PLUMBING INSULATION
22 11 16	DOMESTIC WATER PIPING
22 11 19	DOMESTIC WATER PIPING SPECIALITIES
22 11 23	DOMESTIC WATER PUMPS
22 13 16	SANITARY WASTE, VENT PIPING AND STORM DRAINAGE
22 13 19	SANITARY WASTE PIPING SPECIALITIES
22 14 23	STORM DRAINAGE PIPING SPECIALITIES
22 35 00	DOMESTIC WATER HEAT EXCHANGERS
22 40 00	PLUMBING FIXTURES
22 62 19	VACUUM EQUIPMENT FOR LABORATORY AND HEALTHCARE FACILITIES
22 63 13	GAS PIPING FOR LABORATORY AND HEALTHCARE FACILITIES

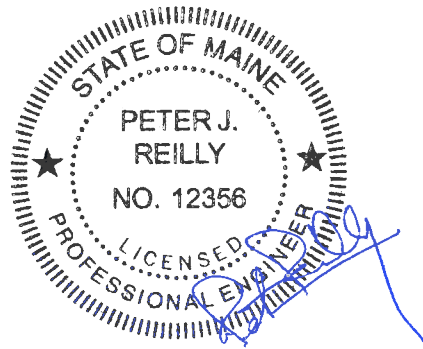

This page is intentionally left blank.

Section 22 00 00

PLUMBING GENERAL PROVISIONS

PART 1 - GENERAL

1.1 GENERAL REQUIREMENTS

- A. Work of this Section, as shown or specified, shall be in accordance with the requirements of the Contract Documents.
- B. Sustainable Building Requirements:
 - 1. The Owner requires the Contractor to implement practices and procedures to meet the project's environmental performance goals, which include achieving LEED version 4 **Certified** level Certification. Specific project goals that may impact this area of work include: use of recycled-content materials; use of locally-manufactured materials; use of low-emitting materials; construction waste recycling; and the implementation of a construction indoor air quality management plan. The Contractor shall ensure that the requirements related to these goals, as defined in the Articles below, are implemented to the fullest extent. Substitutions, or other changes to the work proposed by the Contractor or their Subcontractors, shall not be allowed if such changes compromise the aforementioned environmental goals and LEED certification.

1.2 DEFINITIONS

- A. "Provide": to supply, install, and make complete, safe, and operable, the particular work referred to unless specifically indicated otherwise.
- B. "Install": to erect, mount, and make complete with all related accessories.
- C. "Furnish" or "supply": to purchase, procure, acquire, and deliver complete with related accessories.
- D. "Work": labor, materials, equipment, services, and all related accessories necessary for the proper and complete installation of complete systems.
- E. "Piping": pipe, tube, fittings, flanges, valves, controls, strainers, hangers, supports, unions, traps, drains, insulation and all related accessories.
- F. "Wiring": raceway, fittings, wire, boxes and all related accessories.
- G. "Indicated," "shown," or "noted": as indicated, shown, or noted on drawings or specifications.
- H. "Similar" or "equal": of base bid manufacture, equal in quality materials, weight, size, performance, design, and efficiency of specified product, conforming with "Base Bid Manufacturers."
- I. "Reviewed" "satisfactory," "accepted," or "directed": as reviewed, satisfactory, accepted, or directed by Architect and/or Engineer.
- J. "Motor Controllers": manual or magnetic starters with or without switches, individual pushbuttons or hand-off-automatic (HOA) switches controlling the operation of motors.

- K. "Control or Actuating Devices": automatic sensing and switching devices such as thermostats, pressure, float, flow, operation of equipment.
- L. Finished Spaces: Spaces other than mechanical and electrical equipment rooms, furred spaces, pipe and duct shafts, unheated spaces immediately below roof, spaces above ceilings, unexcavated spaces, crawl spaces, and tunnels.
- M. Exposed, Interior Installations: Exposed to view indoors. Examples include finished occupied spaces and mechanical equipment rooms.
- N. Exposed, Exterior Installations: Exposed to view outdoors, or subject to outdoor ambient temperatures and weather conditions. Examples include rooftop locations.
- O. Concealed, Interior Installations: Concealed from view and protected from physical contact by building occupants. Examples include above ceilings and in duct shafts.
- P. Concealed, Exterior Installations: Concealed from view and protected from weather conditions and physical contact by building occupants, but subject to outdoor ambient temperatures. Examples include installations within unheated shelters.
- Q. The following are industry abbreviations for plastic materials:
 - 1. ABS: Acrylonitrile-butadiene-styrene plastic.
 - 2. CPVC: Chlorinated polyvinyl chloride plastic.
 - 3. NP: Nylon plastic.
 - 4. PE: Polyethylene plastic.
 - 5. PVC: Polyvinyl chloride plastic.
- R. The following are industry abbreviations for rubber materials:
 - 1. CR: Chlorosulfonated polyethylene synthetic rubber.
 - 2. EPDM: Ethylene propylene diene terpolymer rubber.

1.3 WORK INCLUDED

- A. The work covered by this section includes the construction described in the Contract Documents including all labor necessary to perform and complete such construction, all materials and equipment incorporated or to be incorporated in such construction, and all services, facilities, tools and equipment necessary or used to perform and complete such construction. The work includes, but is not limited to the following:
 - 1. Domestic Water Systems.
 - 2. Soil, Waste, Vent and Storm Water Systems.
 - 3. Piping, Valves and Fittings
 - 4. Water Meters and Backflow Prevention Devices
 - 5. Insulation.
 - 6. Domestic Water Heaters.
 - 7. Pumps.
 - 8. Medical Vacuum Source Equipment.
 - 9. Medical Air Source Equipment.
 - 10. Medical Gas Pipe and Valves.
 - 11. Medical Gas Outlets.
 - 12. Medical Gas Alarms.
 - 13. Pressure Tanks.
 - 14. Identification System.
 - 15. Excavation and Backfill.
 - 16. Cutting, Patching and Equipment Painting.
 - 17. Hangers, Supports and Guides.
 - 18. Electric Motors.
 - 19. Electric Motor Controllers.

20. Internal Wiring of Factory-Assembled Prewired Equipment.
21. Alarm Wiring, except for Fire Alarm.
22. Rigging of Equipment.
23. Furnishing access Doors and Frames to be installed by the General Contractor.
24. Fire Stopping for Pipe Penetration.
25. Pipe Penetration and Drains Counterflashing.
26. Concrete Pads for Equipment.
27. Alarm Initiating Devices.
28. Wiring between Water Meter Totalizer and Remote Reading Device.

B. Related Work not Included in this Division but Specified Elsewhere

1. Fire alarm wiring.
2. Finish painting, except for prefinished equipment or as otherwise specified.
3. Concrete work, except equipment inertia and floating bases.
4. Base flashing for piping and drains.
5. Toilet accessories.
6. Waterproofing.
7. Power wiring for motors and motor controllers.
8. Installation of access doors and frames.

1.4 COORDINATION OF WORK

- A. The plumbing drawings show the general arrangement of piping and appurtenances. Follow these drawings as closely as the actual construction will permit. Conform the plumbing work to the requirements shown on the drawings. Provide offsets, fittings, and accessories, which may be required but not shown on the drawings. Investigate the site, structural and finish ground conditions affecting the work, and arrange the work accordingly. Provide such work and accessories as may be required to meet such conditions.
- B. Certain materials will be provided by other trades. Examine the Contract Documents to ascertain these requirements.
- C. Carefully check space requirements with other trades to insure that all material can be installed in the spaces allotted thereto including finished suspended ceilings.
- D. Transmit to other trades all information required for work to be provided under their sections, in ample time for installation.
- E. Wherever work interconnects with work specified of other trades, coordinate with the General Contractor to insure that all necessary information is presented so that all the necessary connections and equipment may be properly installed. Identify all items (valves, piping, equipment, etc.) in order that the General Contractor know where to install access doors and panels.
- F. Consult with other trades regarding equipment so that, wherever possible, motors, motor controls, pumps and valves are of the same manufacturer.
- G. Furnish and set all sleeves for passage of pipes and conduits through structural masonry and concrete walls and floors and elsewhere as will be required for the proper protection of each pipe passing through building surfaces.
- H. Provide required supports and hangers for piping and equipment, designed so as not to exceed allowable loadings of structures.
- I. Examine and compare the contract drawings and specifications with the drawings and specifications of other disciplines, and report any discrepancies between them to the General Contractor and obtain from him written instructions for changes

necessary in the work of this Section. Install and coordinate the work of this section in cooperation with installing interrelated work. Before installation, take proper provisions to avoid interferences. All changes required in the work of the contractor, caused by his neglect to do so, to be made by him at his own expense.

- J. Wherever the work is of sufficient complexity, prepare additional detail drawings to scale similar to that of the design drawings, prepared on tracing medium of the same size as contract drawings. With these layouts, coordinate the work with the work of the contractor. Such detailed work is to be clearly identified on the drawings as to the area to which it applies. Submit these drawings to the Engineer for review. At completion, however, include a set of such drawings with each set of as-built drawings. When directed by the Engineer, submit drawings for review, clearly showing the work of this section and its relation to the work of other disciplines before commencing shop fabrication or erection in the field.
- K. Before commencing work, examine all adjoining work on which this work is in any way dependent for perfect workmanship and report any conditions, which prevent performance of first class work. Become thoroughly familiar with actual existing conditions to which connections must be made or which must be changed or altered.
- L. Provide required anchor bolts, sleeves, inserts and supports. Direct location of anchor bolts, sleeves, inserts and supports to insure that they are properly installed. Any expense resulting from the improper location or installation of anchor bolts, sleeves, inserts and supports to be paid for by the contractor.
- M. Slots, chases, openings and recesses through floors, walls, ceilings, and roofs will be provided by the various trades in their respective materials. Properly locate such openings and be responsible for any cutting and patching caused by the neglect to do so.
- N. Adjust location of pipes, panels, equipment, etc., to accommodate the work to prevent interferences, both anticipated and encountered. Determine the exact route and location of each pipe prior to fabrication.
 - 1. Right-of-Way: Lines, which pitch has the right-of-way over those that do not pitch, i.e., plumbing drains. Lines whose elevations cannot be changed have right-of-way over lines whose elevations can be changed.
 - 2. Make offsets, transitions and changes in direction in pipes as required to maintain proper head room and pitch on sloping lines whether or not indicated on the drawings. Furnish and install all traps, air vents, drains, etc., as required to affect these offsets, transitions and changes in direction.
- O. Install all plumbing work to permit the removal (without damage to other parts) of water heaters and all other equipment requiring periodic replacement or maintenance. Arrange pipes and equipment to permit access to valves, cocks, starters, motors, and control components, and to clear the openings of swinging doors and access panels.
- P. Provide access panels in equipment as required for inspection and maintenance of internal parts, etc.
- Q. The contractor shall coordinate his work with the work of other trades.
- R. Coordinated Composite Drawings
 - 1. The Contractor shall prepare full coordinated composite drawings for the mechanical, electrical and fire protection trades. The Contractor shall overlay each trade's work (in separate colors) on a sepia set of sheetmetal drawings. All conflicts and potential conflicts shall be clearly identified on the sepia sheetmetal drawings. This shall include but not be limited to conflicts with

lights, equipment, piping, ductwork and supports of other trades, as well as conflicts with architectural and structural walls, columns, ceilings and structural beams. Contractor shall have representatives of each trades, as well as conflicts with architectural and structural walls, columns, ceilings and structural beams. Contractor shall have representatives of each trade attend a weekly job site coordination meeting in the Contractor's field office. All trades shall resolve conflicts at these meetings and sign off each sepiia sheetmetal drawing indicating acceptance and satisfactory resolution to all conflicts. All conflicts that cannot be resolved shall be brought to the attention of the Engineer for resolution.

1.5 USE OF SITE AND LOAD LIMITATIONS

- A. The contractor shall review all available data on the location and types of pipelines and other underground utilities. The contractor shall not operate equipment over the facilities and shall take care not to damage them or otherwise impair their use. The contractor shall make investigation to verify the location of these facilities before proceeding with construction and/or operations in their vicinity.

1.6 CONTRACTOR'S RESPONSIBILITY FOR EVALUATION

- A. The Engineer and Owner make no representations, regarding the character or extent of the subsoils, water levels, existing structural, mechanical and electrical installations, above or below ground or other subsurface conditions which may be encountered during the Work. The contractor must make his own evaluation of existing conditions, which may affect methods or cost of performing the Work, based on his own examination of the facility or other information. Failure to examine the drawings or other information shall not relieve the contractor of his responsibility for satisfactory accomplishment of the Work.
- B. The locations of existing services are believed to be as indicated on the plans. The contractor shall verify the location of these services prior to commencing any work and notify the Engineer of any discrepancies.

1.7 ACCESS TO FIRE PROTECTION EQUIPMENT

- A. The contractor shall not interfere with access to hydrants, fire exits, fire hose stations, fire extinguishers and fire alarm pull stations. In no case shall the contractor's material or equipment be within twenty-five (25) ft of a hydrant or fire alarm pull station.

1.8 EQUIPMENT AND MATERIALS

- A. If products and materials are specified or indicated on the drawings for a specific item or system, the contractor shall use those products or materials. If products and materials are not listed in either of the above, use first class products and materials, in accordance with shop drawings.
- B. All products and materials shall be new, clean, free of defects and free of damage and corrosion.
- C. No permanent equipment shall be used to provide temporary services during construction.

- D. Ship and store all products and materials in a manner which will protect them from damage, weather and entry of debris. If items are damaged, do not install, but take immediate steps to obtain replacement or repair.
- E. Make certain that all materials selected directly, or by suppliers, conform to the requirements of the contract drawings and specification. Transmittal of such specifications and drawings, information to persons manufacturing and supplying materials to the project, and rigid adherence thereto, is the Contractor's responsibility. Acceptance of a manufacturer's name by the Engineer does not release the Contractor of the responsibility for providing materials, which comply in all respects with the requirements in the Contract Documents.
- F. Applicable equipment and materials to be listed by Underwriters' Laboratories and Manufactured in accordance with ASME, AWWA, or ANSI standards, and as approved by local authorities having jurisdiction.
- G. Fully lubricate all equipment when installed and prior to final acceptance.
- H. Do not operate water systems until piping has been tested and cleaned.
- I. Secure equipment with bolts, washers and locknuts of ample size to support equipment. Embedded anchor bolts to have bottom plate and pipe sleeves. Grout all machinery set in concrete under the entire bearing surface. After grout has set, remove all wedges, shims and jack bolts and fill space with grout.
- J. Locate valves, traps, access doors, etc., to be easily accessible, either in mechanical spaces or through access panels specified herein.
- K. Follow manufacturers' instructions for installing, connecting, and adjusting all equipment. Provide one copy of such instructions to the Engineer before installing any equipment. Provide a copy of such instructions at the equipment during any work on the equipment. Provide all special valves, piping, wiring and accessories.

1.9 QUALITY ASSURANCE

- A. Codes, Standards and Fees
 - 1. Codes and Standards:
 - a. Comply with all current governing codes, ordinances and regulations, UL and all other applicable codes.
 - b. Comply with the requirements of the State adopted Building Code, and other agencies or authorities having jurisdiction over any part of the Work and secure all necessary permits.
 - c. Where codes or standards are listed herein, the applicable portions apply.
 - d. Plans, specifications, codes and standards are all minimum requirements. Where requirements differ, apply the more stringent.
 - e. Should any change in plans or specifications be required to comply with governing regulations, the contractor is to notify the Engineer at the pre-bid meeting.
 - f. The codes and standards listed in the Specifications can be obtained from the organizations listed as follows:
 - 1) OSHA Occupational Safety and Health Act
 - 2) ANSI American National Standard Institute, Inc.
 - 3) ASME American Society of Mechanical Engineers
 - 4) ASTM American Society for Testing and Materials
 - 5) AWWA American Water Works Association
 - 6) UL Underwriters Laboratories, Inc.

- 7) ASHRAE American Society of Heating, Refrigerating and Air Conditioning Engineers
 - 8) NEMA National Electrical Manufacturers Association
 - 9) AIA American Insurance Association
 - 10) AWS American Welding Society
 - 11) ASA American Standards Association
 - 12) IEEE Institute of Electrical and Electronics Engineers
 - 13) NEC National Electrical Code
 - g. The particular specification will be identified by appropriate prefix and number only with the latest revision being applicable unless otherwise noted.
2. Fees
- a. Pay all required fees.
 - b. Pay royalties or fees required in connection with the use of patented devices and systems.
- B. Furnish all materials and equipment new, free from defects and with listings or labels of Underwriter's Laboratories, Inc. or other nationally approved testing laboratory.
- C. All items of a given type shall be the product of the same manufacturer.
- D. All materials and equipment shall be the product of manufacturers regularly engaged in their manufacture.
- 1.10 SHOP DRAWINGS
- A. Prepare and submit detailed shop drawings for piping work and other distribution services, including locations and sizes of all openings in floor walls and roofs.
 - B. The work described in any shop drawing submission to be carefully checked for all clearances (including those required for maintenance and servicing), field conditions, maintenance of architectural conditions and proper coordination with all trades on the job. Each submitted shop drawing to include a certification that all related job conditions have been checked and that no conflict exists.
 - C. All drawings to be submitted sufficiently in advance of field requirements to allow ample time for checking. All submittals to be complete and contain all required and detailed information. Shop drawings with multiple parts to be submitted as a package.
 - D. If submittals differ from the Contract Document requirements, make specific mention of such difference in a letter of transmittal, with request for substitution, together with reasons for same.
 - E. Review of any submitted data or shop drawings for material, equipment apparatus, devices, arrangement and layout shall not relieve the contractor from responsibility of furnishing same of proper dimensions and weight, capacities, sizes, quantity, quality and installation details to efficiently perform the requirements and intent of the Work. Such review shall not relieve the contractor from responsibility for errors, omissions or inadequacies of any sort on submitted data or shop drawings.
 - F. Each shop drawing is to contain the job title, the names and phone numbers of the General Contractor and the contractor, references to the applicable design drawing or specification article, date and scale.
 - G. Within fifteen (15) days after award of Contract, submit for review, a list of all material and equipment manufacturers whose products are proposed, as well as names of all Subcontractors whom the General Contractor proposes to employ.

- H. Within three (3) weeks after award of Contract, submit a list of all shop drawings, which will be submitted in the course of the project. List to show disposition of each item, including date of submission, review, and the like. List to be kept up-to-date throughout entire construction period.
- I. Submit shop drawings and manufacturer's data for the following items in accordance with the Contract Documents:
 - 1. Coordinated, detailed shop layout drawings of all mechanical rooms, services and distribution systems, including plans, profiles and sections.
 - 2. Details of piping supports, elbows, anchors and miscellaneous appurtenances.
 - 3. Hangers, supports, inserts, anchors, guides and foundations.
 - 4. Valves.
 - 5. Pressure gauges and thermometers.
 - 6. Corrosion protective coatings.
 - 7. Equipment and piping layouts at 3/8 in. scale for the building.
 - 8. Location and size of sleeves for openings in floors and walls.
 - 9. Certified equipment performance curves for pumps.
 - 10. Schedule of pipe and fittings, materials and application, valves, escutcheons, air vents, valve tags and schedules, strainers, and water specialties.
 - 11. Pump system, including pumps, motors and controllers.
 - 12. Building automation systems including descriptions, instruments, and alarms.
 - 13. Flashing.
 - 14. Equipment identification and certificates.
 - 15. Pressure tanks and accessories.
 - 16. Water heaters and accessories.
 - 17. Plumbing fixture and trim.
 - 18. Medical Gas Equipment Outlets, Valves and Alarms.
 - 19. Other shop drawings and submittals as requested within the specification.

1.11 SAMPLES

- A. Submit samples of all items with exposed finishes for review.
- B. Allow sufficient time for consideration without interfering with job schedule.
- C. Duplicate quality and finish to type to be supplied under contract.
- D. Identify similar to shop drawings.

1.12 ELECTRONIC COPIES OF AKF DRAWINGS

- A. Upon award of contract, contractor shall submit list of drawings that they will require. AKF will provide drawings in (.PDF) format only.
- B. If the contractor requires (.dwg) format, there will be a charge of \$200 for each drawing supplied plus shipping and handling for preparation and processing. After preparation the drawings will be forwarded only upon receipt of signed acceptance of terms form. Permission from the architect must first be obtained for AKF to include the architectural background as reference. The contractor is to obtain the architects latest drawings directly from the architect.
- C. These files are being issued for the convenience of the contractor and the contractor remains responsible for all contract requirements related to the normal shop drawing preparation process.

1.13 SUBMISSIONS:

- A. Provide all coordination drawings and shop drawings in 'AutoCad' format, version compatible with owner. All catalog cuts and submittals to be provided in electronic "PDF" format the architect will forward all submissions to the engineer.
- B. If paper submissions are to be provided the following shall be adhered to.
 - 1. Submissions 11 in. X 17 in. or smaller: If the submission is a catalog cut, then the contractor shall submit one original and one copy. Otherwise, they shall submit two copies. The architect will forward the original and one copy (two copies when no original is received) to the engineer. All catalog cuts shall be complete.
 - 2. Submissions larger than 11 in. X 17 in.: submit two copies to the architect. The architect will forward to the engineer.
- C. Indicate on each submission: project name and location, architect and engineer, item identification and approval stamp of prime contractor, subcontractor names and phone numbers, reference to the applicable design drawing or specification article, date and scale.
- D. The work described in all shop drawing submission shall be carefully checked for all clearances (including those required for maintenance and servicing), field conditions, maintenance of architectural conditions and proper coordination with all trades on the job.
- E. Each submitted shop drawing is to include a certification that all related job conditions have been checked and verified and that there are no conflicts.
- F. All shop drawings are to be submitted to allow ample time for checking in advance of field requirements. All submittals to be complete and contain all required and detailed information. Shop drawings with multiple parts shall be submitted as a package.
- G. If submittals differ from the contract document requirements, make specific mention of such difference in a letter of transmittal, with request for substitution, together with reasons for same.

1.14 AS-BUILTS AND EQUIPMENT OPERATION INSTRUCTIONS

- A. Provide all coordination drawings and shop drawings in AutoCad format, version compatible with owner. All catalog cuts and submittals to be provided in electronic "PDF" format the architect will forward all submissions to the engineer.
- B. On completion and acceptance of work, this contractor shall furnish written instructions, equipment manuals and demonstrate to the owner the proper operation and maintenance of all equipment and apparatus furnished under this contract.
- C. The contractor shall give one copy of the instructions to the owner and one copy to the engineer. .
- D. Final "as-built" drawings indicating as installed conditions shall be provided to the architect and engineer after completion of the installation.

1.15 START-UP

- A. Properly lubricate all pieces of equipment.
- B. Check and clean all pipes of dirt and debris, including strainers.
- C. Prepare each piece of equipment in accordance with manufacturer's installation instructions and have a copy at the equipment.

- D. Fill and vent all water systems.
- E. Check rotation on each motor.
- F. Have representatives of each manufacturer present when hereinafter specified, so that equipment will be started up by manufacturer.

1.16 ACCESS DOORS IN FINISHED CONSTRUCTION

- A. Furnish access doors as required for operation and maintenance of concealed equipment, clean-outs, valves, shock absorbers, controls, etc., and coordinate their delivery with the installing trade.
- B. Coordinate and prepare a location, size and function schedule of access doors required and deliver to the General Contractor and the Architect for review.
- C. Doors shall be of a size required for operating and repacking valves, and shall be as manufactured by Karp Associates, Nystrom Inc., or Mifab.
- D. Unless otherwise indicated, minimum size to be 18" x 18".
- E. Furnish color coded buttons or tabs to indicate location of valves or other equipment located above removable type ceilings where access doors are not required.
- F. Access doors shall have a fire rating compatible with the wall construction in which they are located.

1.17 SYSTEM IDENTIFICATION

- A. Piping:
 - 1. All piping, exposed or concealed shall be identified as to its service in accordance with OSHA and ANSI Standards by one of the following methods:
 - a. Installation of manufactured adhesive band type identification markers, similar to "Quick-Label" by W.H. Brady Company.
 - 2. Piping identification markings shall be installed as follows:
 - a. In each room.
 - b. All valve locations.
 - c. At shaft walls.
 - d. Every 40 feet on continuous runs.
 - 3. Valves:
 - a. Valves shall be identified by a tag system utilizing brass tags at 2 inch minimum diameter and attached to the valves using brass chain.
 - 1) The new valve tag identification numbers shall be permanently added to all existing valve tag charts within the building.
 - 4. Equipment:
 - a. Identify all controls such as motor starters not in motor control centers, float switches, and alarms.

1.18 OPERATING & MAINTENANCE INSTRUCTION

- A. Prepare operating and maintenance instructions manual including operating instructions, maintenance instructions, manufacturer's data, specific equipment data.
- B. Provide an alphabetical list of all system components, with the name, address, and 24-hour phone number of the company responsible for servicing each item during the first year of operation.
- C. Provide operating instructions for complete system, including:

1. Normal starting, operating, and shut-down
2. Emergency procedures for fire or failure of major equipment
- D. Provide maintenance instructions, including:
 1. Valve tag list and equipment tag list
 2. Proper lubricants and lubricating instructions for each piece of equipment, and date when lubricated
 3. Required cleaning, replacement and/or adjustment schedule
- E. Provide manufacturer's data on each piece of equipment, including:
 1. Installation instructions.
 2. Drawings and specifications.
 3. Parts list, including recommended items to be stocked.
 4. Complete wiring and temperature control diagrams.
 5. Marked or revised prints locating all concealed parts and all variations from the original system design.
 6. Test and inspection certificates.
- F. Provide specific equipment data including, but not limited to, the following:
 1. For Plumbing Systems:
 - a. Pumps.
 - b. Valves.
 - c. Piping.
 - d. Accessories.
 - e. Pressure reducing valves.
 - f. Water heaters.
 - g. Water meters.
 - h. Strainers.
 - i. Toilet fixtures and supports.
 - j. Toilet fixture trim.
 - k. Flow measuring devices.
 - l. Electric wiring.
 - m. Pressure tanks.
 - n. Medical equipment, valves outlets and alarms.
 2. For Automatic Control System:
 - a. Drawings and description of system controlled.
 - b. Sequence of operation for each system.
 - c. Data on components.
 - d. Wiring and piping, schematic any layout, for panels and panelboards.
 - e. System operating manual, including set points.
- G. Provide instruction of operating personnel.
 1. Instruct Owner's operating personnel in proper starting sequences, operation, shutdown, and maintenance procedures, including normal and emergency procedures.
 2. Instruction to be by personnel skilled in operation of equipment. Instructions for major equipment to be by equipment manufacturers' representatives.
 3. Make arrangements to give instructions by system and not by building areas.
 4. Provide five (5) instruction sessions not to exceed six (6) hours each.
 5. Instructions on automatic controls to be by manufacturer's representative.
- H. Submittals
 1. Shop Drawings: Submit three copies for review prior to final issuance.
 2. Provide six (6) copies of each operation and maintenance manual.
 - a. Manuals to be 8-1/2" x 11 size in hard-back, 3-ring loose leaf binders. Use more than one volume if required. Do not overfill binders.

- b. Manuals to be completed and delivered to the Engineer for approval at least 20 days prior to instruction of operating personnel.
- 3. Prepare separate manuals for the Plumbing system.

1.19 TOOLS FOR OPERATION, ADJUSTMENT AND MAINTENANCE

- A. Deliver to Owner's representative all special tools needed for proper operation, adjustment and maintenance of equipment.

1.20 RECORD DRAWINGS

- A. The contractor shall maintain a complete set of "Record Drawings" reflecting an accurate dimensional record of all work. These drawings shall be marked up to show the precise location of concealed work and equipment, including concealed piping and valves and all changes and deviations in the plumbing work from that shown on the contract drawings. This requirement shall not be construed as authorization for the contractor to make changes in the layout or work without written definite instruction from the Architect or Engineer.
- B. Record dimensions shall clearly and accurately delineate the work as installed; location shall be suitably identified by at least two dimensions to permanent structures.
- C. The contractor shall stamp all "Record Drawings" and certify for correctness by signing and dating them.
- D. Record drawings submitted to Owner shall consist of 1 set of mylars and 1 set of compact disk's (CD's) with all work provided on Autocad 2000 format.
- E. Prior to final acceptance, contractor shall submit certified "Record Drawings" to the Architect/Engineer for review and make changes, corrections or additions as noted by Architect/Engineer. After this review, the drawing shall be delivered to the Owner.

PART 2 - PRODUCTS

NOT USED.

PART 3 - EXECUTION

NOT USED.

END OF SECTION

SECTION 22 05 00

COMMON WORK RESULTS FOR PLUMBING

PART 1 - GENERAL

1.1 RELATED DOCUMENTS

- A. Drawings and general provisions of the Contract, including General and Supplementary Conditions and Division 01 Specification Sections, apply to this Section.
- B. Section 01 81 13 "Sustainable Design Requirements – LEED v4 for Building Design & Construction – New Construction" for sustainable design requirements and detailed sustainable design submittal requirements.
- C. Section 01 74 19 "Construction and Demolition Waste Management and Disposal" for disposal of construction, demolition and packaging waste disposal requirements.

1.2 SUMMARY

- A. This Section includes the following:
 - 1. Piping materials and installation instructions common to most piping systems.
 - 2. Transition fittings.
 - 3. Dielectric fittings.
 - 4. Mechanical sleeve seals.
 - 5. Sleeves.
 - 6. Escutcheons.
 - 7. Grout.
 - 8. Plumbing demolition.
 - 9. Equipment installation requirements common to equipment sections.
 - 10. Painting and finishing.
 - 11. Concrete bases.
 - 12. Supports and anchorages.
- B. Sustainable Building Requirements:
 - 1. The Owner requires the Contractor to implement practices and procedures to meet the project's environmental performance goals, which include achieving LEED version 4 **Certified** level Certification. Specific project goals that may impact this area of work include: use of recycled-content materials; use of locally-manufactured materials; use of low-emitting materials; construction waste recycling; and the implementation of a construction indoor air quality management plan. The Contractor shall ensure that the requirements related to these goals, as defined in the Articles below, are implemented to the fullest extent. Substitutions, or other changes to the work proposed by the Contractor or their Subcontractors, shall not be allowed if such changes compromise the aforementioned environmental goals and LEED certification.

1.3 DEFINITIONS

- A. Finished Spaces: Spaces other than mechanical and electrical equipment rooms, furred spaces, pipe chases, unheated spaces immediately below roof, spaces above ceilings, unexcavated spaces, crawlspaces, and tunnels.
- B. Exposed, Interior Installations: Exposed to view indoors. Examples include finished occupied spaces and mechanical equipment rooms.
- C. Exposed, Exterior Installations: Exposed to view outdoors or subject to outdoor ambient temperatures and weather conditions. Examples include rooftop locations.
- D. Concealed, Interior Installations: Concealed from view and protected from physical contact by building occupants. Examples include above ceilings and in chases.
- E. Concealed, Exterior Installations: Concealed from view and protected from weather conditions and physical contact by building occupants but subject to outdoor ambient temperatures. Examples include installations within unheated shelters.
- F. The following are industry abbreviations for plastic materials:
 - 1. ABS: Acrylonitrile-butadiene-styrene plastic.
 - 2. CPVC: Chlorinated polyvinyl chloride plastic.
 - 3. PE: Polyethylene plastic.
 - 4. PVC: Polyvinyl chloride plastic.
- G. The following are industry abbreviations for rubber materials:
 - 1. EPDM: Ethylene-propylene-diene terpolymer rubber.
 - 2. NBR: Acrylonitrile-butadiene rubber.

1.4 SUBMITTALS

- A. Product Data: For the following:
 - 1. Transition fittings.
 - 2. Dielectric fittings.
 - 3. Mechanical sleeve seals.
 - 4. Escutcheons.
- B. Welding certificates.

1.5 QUALITY ASSURANCE

- A. Steel Support Welding: Qualify processes and operators according to AWS D1.1, "Structural Welding Code--Steel."
- B. Steel Pipe Welding: Qualify processes and operators according to ASME Boiler and Pressure Vessel Code: Section IX, "Welding and Brazing Qualifications."
 - 1. Comply with provisions in ASME B31 Series, "Code for Pressure Piping."
 - 2. Certify that each welder has passed AWS qualification tests for welding processes involved and that certification is current.
- C. Electrical Characteristics for Plumbing Equipment: Equipment of higher electrical characteristics may be furnished provided such proposed equipment is approved in writing and connecting electrical services, circuit breakers, and conduit sizes are appropriately modified. If minimum energy ratings or efficiencies are specified, equipment shall comply with requirements.

1.6 DELIVERY, STORAGE, AND HANDLING

- A. Deliver pipes and tubes with factory-applied end caps. Maintain end caps through shipping, storage, and handling to prevent pipe end damage and to prevent entrance of dirt, debris, and moisture.
- B. Store plastic pipes protected from direct sunlight. Support to prevent sagging and bending.

1.7 COORDINATION

- A. Arrange for pipe spaces, chases, slots, and openings in building structure during progress of construction, to allow for plumbing installations.
- B. Coordinate installation of required supporting devices and set sleeves in poured-in-place concrete and other structural components as they are constructed.
- C. Coordinate requirements for access panels and doors for plumbing items requiring access that are concealed behind finished surfaces. Access panels and doors are specified in Division 08 Section "Access Doors and Frames."

PART 2 - PRODUCTS

2.1 MANUFACTURERS

- A. In other Part 2 articles where subparagraph titles below introduce lists, the following requirements apply for product selection:

2.2 PIPE, TUBE, AND FITTINGS

- A. Refer to individual Division 22 piping Sections for pipe, tube, and fitting materials and joining methods.
- B. Pipe Threads: ASME B1.20.1 for factory-threaded pipe and pipe fittings.

2.3 JOINING MATERIALS

- A. Refer to individual Division 22 piping Sections for special joining materials not listed below.
- B. Pipe-Flange Gasket Materials: Suitable for chemical and thermal conditions of piping system contents.
 - 1. ASME B16.21, nonmetallic, flat, asbestos-free, 1/8-inch (3.2-mm) maximum thickness unless thickness or specific material is indicated.
 - a. Full-Face Type: For flat-face, Class 125, cast-iron and cast-bronze flanges.
 - b. Narrow-Face Type: For raised-face, Class 250, cast-iron and steel flanges.
 - 2. AWWA C110, rubber, flat face, 1/8 inch (3.2 mm) thick, unless otherwise indicated; and full-face or ring type, unless otherwise indicated.
- C. Flange Bolts and Nuts: ASME B18.2.1, carbon steel, unless otherwise indicated.
- D. Plastic, Pipe-Flange Gasket, Bolts, and Nuts: Type and material recommended by piping system manufacturer, unless otherwise indicated.

- E. Solder Filler Metals: ASTM B 32, lead-free alloys. Include water-flushable flux according to ASTM B 813.
- F. Brazing Filler Metals: AWS A5.8, BCuP Series, copper-phosphorus alloys for general-duty brazing, unless otherwise indicated; and AWS A5.8, BAg1, silver alloy for refrigerant piping, unless otherwise indicated.
- G. Welding Filler Metals: Comply with AWS D10.12 for welding materials appropriate for wall thickness and chemical analysis of steel pipe being welded.
- H. Solvent Cements for Joining Plastic Piping:
 - 1. ABS Piping: ASTM D 2235.
 - 2. CPVC Piping: ASTM F 493.
 - 3. PVC Piping: ASTM D 2564. Include primer according to ASTM F 656.
 - 4. PVC to ABS Piping Transition: ASTM D 3138.
- I. Fiberglass Pipe Adhesive: As furnished or recommended by pipe manufacturer.

2.4 TRANSITION FITTINGS

- A. AWWA Transition Couplings: Same size as, and with pressure rating at least equal to and with ends compatible with, piping to be joined.
 - 1. Manufacturers:
 - a. Cascade Waterworks Mfg. Co.
 - b. Dresser Industries, Inc.; DMD Div.
 - c. Ford Meter Box Company, Incorporated (The); Pipe Products Div.
 - d. JCM Industries.
 - 2. Underground Piping NPS 1-1/2 (DN 40) and Smaller: Manufactured fitting or coupling.
 - 3. Underground Piping NPS 2 (DN 50) and Larger: AWWA C219, metal sleeve-type coupling.
 - 4. Aboveground Pressure Piping: Pipe fitting.

2.5 DIELECTRIC FITTINGS

- A. Description: Combination fitting of copper alloy and ferrous materials with threaded, solder-joint, plain, or weld-neck end connections that match piping system materials.
- B. Insulating Material: Suitable for system fluid, pressure, and temperature.
- C. Dielectric Unions: Factory-fabricated, union assembly, for 250-psig (1725-kPa) minimum working pressure at 180 deg F (82 deg C).
 - 1. Manufacturers:
 - a. Capitol Manufacturing Co.
 - b. Central Plastics Company.
 - c. Eclipse, Inc.
 - d. Epco Sales, Inc.
 - e. Hart Industries, International, Inc.
 - f. Watts Industries, Inc.; Water Products Div.
 - g. Zurn Industries, Inc.; Wilkins Div.
- D. Dielectric Flanges: Factory-fabricated, companion-flange assembly, for 150- or 300-psig (1035- or 2070-kPa) minimum working pressure as required to suit system pressures.
 - 1. Manufacturers:

- a. Capitol Manufacturing Co.
 - b. Central Plastics Company.
 - c. Epcos Sales, Inc.
 - d. Watts Industries, Inc.; Water Products Div.
- E. Dielectric-Flange Kits: Companion-flange assembly for field assembly. Include flanges, full-face- or ring-type neoprene or phenolic gasket, phenolic or polyethylene bolt sleeves, phenolic washers, and steel backing washers.
1. Manufacturers:
 - a. Advance Products & Systems, Inc.
 - b. Calpico, Inc.
 - c. Central Plastics Company.
 - d. Pipeline Seal and Insulator, Inc.
 2. Separate companion flanges and steel bolts and nuts shall have 150- or 300-psig (1035- or 2070-kPa) minimum working pressure where required to suit system pressures.
- F. Dielectric Couplings: Galvanized-steel coupling with inert and noncorrosive, thermoplastic lining; threaded ends; and 300-psig (2070-kPa) minimum working pressure at 225 deg F (107 deg C).
1. Manufacturers:
 - a. Calpico, Inc.
 - b. Lochinvar Corp.
- G. Dielectric Nipples: Electroplated steel nipple with inert and noncorrosive, thermoplastic lining; plain, threaded, or grooved ends; and 300-psig (2070-kPa) minimum working pressure at 225 deg F (107 deg C).
1. Manufacturers:
 - a. Perfection Corp.
 - b. Precision Plumbing Products, Inc.
 - c. Sioux Chief Manufacturing Co., Inc.
 - d. Victaulic Co. of America.

2.6 MECHANICAL SLEEVE SEALS

- A. Description: Modular sealing element unit, designed for field assembly, to fill annular space between pipe and sleeve.
1. Manufacturers:
 - a. Thunderline
 - b. Advance Products & Systems, Inc.
 - c. Calpico, Inc.
 - d. Metraflex Co.
 2. Sealing Elements: EPD Minterlocking links shaped to fit surface of pipe. Include type and number required for pipe material and size of pipe.
 3. Pressure Plates: Plastic. Include two for each sealing element.
 4. Connecting Bolts and Nuts: Carbon steel with corrosion-resistant coating of length required to secure pressure plates to sealing elements. Include one for each sealing element.

2.7 SLEEVES

- A. Galvanized-Steel Sheet: 0.0239-inch (0.6-mm) minimum thickness; round tube closed with welded longitudinal joint.

- B. Steel Pipe: ASTM A 53, Type E, Grade B, Schedule 40, galvanized, plain ends.
- C. Cast Iron: Cast or fabricated "wall pipe" equivalent to ductile-iron pressure pipe, with plain ends and integral waterstop, unless otherwise indicated.
- D. Stack Sleeve Fittings: Manufactured, cast-iron sleeve with integral clamping flange. Include clamping ring and bolts and nuts for membrane flashing.
 - 1. Underdeck Clamp: Clamping ring with set screws.

2.8 ESCUTCHEONS

- A. Description: Manufactured wall and ceiling escutcheons and floor plates, with an ID to closely fit around pipe, tube, and insulation of insulated piping and an OD that completely covers opening.
- B. One-Piece, Cast-Brass Type: With set screw.
 - 1. Finish: Polished chrome-plated .
- C. Split-Casting, Cast-Brass Type: With concealed hinge and set screw.
 - 1. Finish: Polished chrome-plated .
- D. One-Piece, Stamped-Steel Type: With set screw and chrome-plated finish.
- E. Split-Plate, Stamped-Steel Type: With concealed hinge, set screw, and chrome-plated finish.
- F. One-Piece, Floor-Plate Type: Cast-iron floor plate.
- G. Split-Casting, Floor-Plate Type: Cast brass with concealed hinge and set screw.

2.9 GROUT

- A. General Purpose Description: ASTM C 1107, Grade B, nonshrink and nonmetallic, dry hydraulic-cement grout.
 - 1. Characteristics: Post-hardening, volume-adjusting, nonstaining, noncorrosive, nongaseous, and recommended for interior and exterior applications.
 - 2. Design Mix: 5000-psi (34.5-MPa), 28-day compressive strength.
 - 3. Packaging: Premixed and factory packaged.
- B. Pump Mounting: High flow, high strength epoxy machine-based grout: ASTM C 881, CRD-C 590.
 - 1. Characteristics: Two to Three-component, highly flowable, epoxy-based grout that produces high performance strength plus chemical inertness and excellent bonding properties.
 - 2. Design Mix: ASTM-C 579, 14,000 / 19,000 psi , 36 hours @72 degree F compressive strength.
 - 3. Packaging: Factory packaged for field mixing.
 - 4. Products: Chocfast by ITW Philadelphia resins, ESCOWELD or approved equal

PART 3 - EXECUTION

3.1 PIPING SYSTEMS - COMMON REQUIREMENTS

- A. Install piping according to the following requirements and Division 22 Sections specifying piping systems.

- B. Drawing plans, schematics, and diagrams indicate general location and arrangement of piping systems. Indicated locations and arrangements were used to size pipe and calculate friction loss, expansion, pump sizing, and other design considerations. Install piping as indicated unless deviations to layout are approved on Coordination Drawings.
- C. Install piping in concealed locations, unless otherwise indicated and except in equipment rooms and service areas.
- D. Install piping indicated to be exposed and piping in equipment rooms and service areas at right angles or parallel to building walls. Diagonal runs are prohibited unless specifically indicated otherwise.
- E. Install piping above accessible ceilings to allow sufficient space for ceiling panel removal.
- F. Install piping to permit valve servicing.
- G. Install piping at indicated slopes.
- H. Install piping free of sags and bends.
- I. Install fittings for changes in direction and branch connections.
- J. Install piping to allow application of insulation.
- K. Select system components with pressure rating equal to or greater than system operating pressure.
- L. Install escutcheons for penetrations of walls, ceilings, and floors according to the following:
 - 1. New Piping:
 - a. Piping with Fitting or Sleeve Protruding from Wall: One-piece cast brass type.
 - b. Chrome-Plated Piping: One-piece, cast-brass type with polished chrome-plated finish.
 - c. Insulated Piping: One-piece, stamped-steel type with spring clips.
 - d. Bare Piping at Wall and Floor Penetrations in Finished Spaces: One-piece, cast-brass type with polished chrome-plated finish.
 - e. Bare Piping at Ceiling Penetrations in Finished Spaces: One-piece, cast-brass type with polished chrome-plated finish.
 - f. Bare Piping in Unfinished Service Spaces: One-piece, cast-brass type with polished chrome-plated finish.
 - g. Bare Piping in Equipment Rooms: One-piece, cast-brass type.
 - h. Bare Piping at Floor Penetrations in Equipment Rooms: One-piece, floor-plate type.
- M. Sleeves are not required for core-drilled holes.
- N. Permanent sleeves are not required for holes formed by removable PE sleeves.
- O. Install sleeves for pipes passing through concrete and masonry walls and concrete floor and roof slabs.
- P. Install sleeves for pipes passing through concrete and masonry walls, gypsum-board partitions, and concrete floor and roof slabs.
 - 1. Cut sleeves to length for mounting flush with both surfaces.
 - a. Exception: Extend sleeves installed in floors of mechanical equipment areas or other wet areas 2 inches (50 mm) above finished floor level.

- Extend cast-iron sleeve fittings below floor slab as required to secure clamping ring if ring is specified.
2. Install sleeves in new walls and slabs as new walls and slabs are constructed.
 3. Install sleeves that are large enough to provide 1/4-inch (6.4-mm) annular clear space between sleeve and pipe or pipe insulation. Use the following sleeve materials:
 - a. SteelPipe Sleeves: For pipes smaller than NPS 6 (DN 150).
 - b. Steel Sheet Sleeves: For pipes NPS 6 (DN 150) and larger, penetrating gypsum-board partitions.
 - c. Stack Sleeve Fittings: For pipes penetrating floors with membrane waterproofing. Secure flashing between clamping flanges. Install section of cast-iron soil pipe to extend sleeve to 2 inches (50 mm) above finished floor level. Refer to Division 07 Section "Sheet Metal Flashing and Trim" for flashing.
 - 1) Seal space outside of sleeve fittings with grout.
 4. Except for underground wall penetrations, seal annular space between sleeve and pipe or pipe insulation, using joint sealants appropriate for size, depth, and location of joint. Refer to Division 07 Section "Joint Sealants" for materials and installation.
- Q. Aboveground, Exterior-Wall Pipe Penetrations: Seal penetrations using sleeves and mechanical sleeve seals. Select sleeve size to allow for 1-inch (25-mm) annular clear space between pipe and sleeve for installing mechanical sleeve seals.
1. Install steel pipe for sleeves smaller than 6 inches (150 mm) in diameter.
 2. Install cast-iron "wall pipes" for sleeves 6 inches (150 mm) and larger in diameter.
 3. Mechanical Sleeve Seal Installation: Select type and number of sealing elements required for pipe material and size. Position pipe in center of sleeve. Assemble mechanical sleeve seals and install in annular space between pipe and sleeve. Tighten bolts against pressure plates that cause sealing elements to expand and make watertight seal.
- R. Underground, Exterior-Wall Pipe Penetrations: Install cast-iron "wall pipes" for sleeves. Seal pipe penetrations using mechanical sleeve seals. Select sleeve size to allow for 1-inch (25-mm) annular clear space between pipe and sleeve for installing mechanical sleeve seals.
1. Mechanical Sleeve Seal Installation: Select type and number of sealing elements required for pipe material and size. Position pipe in center of sleeve. Assemble mechanical sleeve seals and install in annular space between pipe and sleeve. Tighten bolts against pressure plates that cause sealing elements to expand and make watertight seal.
- S. Fire-Barrier Penetrations: Maintain indicated fire rating of walls, partitions, ceilings, and floors at pipe penetrations. Seal pipe penetrations with firestop materials. Refer to Division 07 Section "Penetration Firestopping" for materials.
- T. Verify final equipment locations for roughing-in.
- U. Refer to equipment specifications in other Sections of these Specifications for roughing-in requirements.
- 3.2 PIPING JOINT CONSTRUCTION
- A. Join pipe and fittings according to the following requirements and Division 22 Sections specifying piping systems.

- B. Ream ends of pipes and tubes and remove burrs. Bevel plain ends of steel pipe.
- C. Remove scale, slag, dirt, and debris from inside and outside of pipe and fittings before assembly.
- D. Soldered Joints: Apply ASTM B 813, water-flushable flux, unless otherwise indicated, to tube end. Construct joints according to ASTM B 828 or CDA's "Copper Tube Handbook," using lead-free solder alloy complying with ASTM B 32.
- E. Brazed Joints: Construct joints according to AWS's "Brazing Handbook," "Pipe and Tube" Chapter, using copper-phosphorus brazing filler metal complying with AWS A5.8.
- F. Threaded Joints: Thread pipe with tapered pipe threads according to ASME B1.20.1. Cut threads full and clean using sharp dies. Ream threaded pipe ends to remove burrs and restore full ID. Join pipe fittings and valves as follows:
 - 1. Apply appropriate tape or thread compound to external pipe threads unless dry seal threading is specified.
 - 2. Damaged Threads: Do not use pipe or pipe fittings with threads that are corroded or damaged. Do not use pipe sections that have cracked or open welds.
- G. Welded Joints: Construct joints according to AWS D10.12, using qualified processes and welding operators according to Part 1 "Quality Assurance" Article.
- H. Flanged Joints: Select appropriate gasket material, size, type, and thickness for service application. Install gasket concentrically positioned. Use suitable lubricants on bolt threads.
- I. Plastic Pressure Piping Gasketed Joints: Join according to ASTM D 3139.
- J. Plastic Nonpressure Piping Gasketed Joints: Join according to ASTM D 3212.
- K. PE Piping Heat-Fusion Joints: Clean and dry joining surfaces by wiping with clean cloth or paper towels. Join according to ASTM D 2657.
 - 1. Plain-End Pipe and Fittings: Use butt fusion.
 - 2. Plain-End Pipe and Socket Fittings: Use socket fusion.

3.3 PIPING CONNECTIONS

- A. Make connections according to the following, unless otherwise indicated:
 - 1. Install unions, in piping NPS 2 (DN 50) and smaller, adjacent to each valve and at final connection to each piece of equipment.
 - 2. Install flanges, in piping NPS 2-1/2 (DN 65) and larger, adjacent to flanged valves and at final connection to each piece of equipment.
 - 3. Dry Piping Systems: Install dielectric unions and flanges to connect piping materials of dissimilar metals.
 - 4. Wet Piping Systems: Install dielectric coupling and nipple fittings to connect piping materials of dissimilar metals.

3.4 EQUIPMENT INSTALLATION - COMMON REQUIREMENTS

- A. Install equipment to allow maximum possible headroom unless specific mounting heights are not indicated.
- B. Install equipment level and plumb, parallel and perpendicular to other building systems and components in exposed interior spaces, unless otherwise indicated.

- C. Install plumbing equipment to facilitate service, maintenance, and repair or replacement of components. Connect equipment for ease of disconnecting, with minimum interference to other installations. Extend grease fittings to accessible locations.
- D. Install equipment to allow right of way for piping installed at required slope.

3.5 PAINTING

- A. Painting of plumbing systems, equipment, and components is specified in Division 09 Sections "Interior Painting" and "Exterior Painting."
- B. Damage and Touchup: Repair marred and damaged factory-painted finishes with materials and procedures to match original factory finish.

3.6 CONCRETE BASES

- A. Concrete Bases: Anchor equipment to concrete base according to equipment manufacturer's written instructions and according to seismic codes at Project.
 - 1. Construct concrete bases of dimensions indicated, but not less than 4 inches (100 mm) larger in both directions than supported unit.
 - 2. Install dowel rods to connect concrete base to concrete floor. Unless otherwise indicated, install dowel rods on 18-inch (450-mm) centers around the full perimeter of the base.
 - 3. Install epoxy-coated anchor bolts for supported equipment that extend through concrete base, and anchor into structural concrete floor.
 - 4. Place and secure anchorage devices. Use supported equipment manufacturer's setting drawings, templates, diagrams, instructions, and directions furnished with items to be embedded.
 - 5. Install anchor bolts to elevations required for proper attachment to supported equipment.
 - 6. Install anchor bolts according to anchor-bolt manufacturer's written instructions.
 - 7. Use 3000-psi 28-day compressive-strength concrete and reinforcement as specified in Division 03 Section "

3.7 ERECTION OF METAL SUPPORTS AND ANCHORAGES

- A. Refer to Division 05 Section "Metal Fabrications" for structural steel.
- B. Cut, fit, and place miscellaneous metal supports accurately in location, alignment, and elevation to support and anchor plumbing materials and equipment.
- C. Field Welding: Comply with AWS D1.1.

3.8 ERECTION OF WOOD SUPPORTS AND ANCHORAGES

- A. Cut, fit, and place wood grounds, nailers, blocking, and anchorages to support, and anchor plumbing materials and equipment.
- B. Select fastener sizes that will not penetrate members if opposite side will be exposed to view or will receive finish materials. Tighten connections between members. Install fasteners without splitting wood members.
- C. Attach to substrates as required to support applied loads.

3.9 GROUTING

- A. Mix and install grout for plumbing equipment base bearing surfaces, pump and other equipment base plates, and anchors.
- B. Clean surfaces that will come into contact with grout.
- C. Provide forms as required for placement of grout.
- D. Avoid air entrapment during placement of grout.
- E. Place grout, completely filling equipment bases.
- F. Place grout on concrete bases and provide smooth bearing surface for equipment.
- G. Place grout around anchors.
- H. Cure placed grout.

END OF SECTION

This page is intentionally left blank.

Section 22 05 13

COMMON MOTOR REQUIREMENTS FOR PLUMBING EQUIPMENT

PART 1 - GENERAL

1.1 RELATED DOCUMENTS

- A. Drawings and general provisions of the Contract, including General and Supplementary Conditions and Division 01 Specification Sections, apply to this Section.
- B. Section 01 81 13 "Sustainable Design Requirements – LEED v4 for Building Design & Construction – New Construction" for sustainable design requirements and detailed sustainable design submittal requirements.
- C. Section 01 74 19 "Construction and Demolition Waste Management and Disposal" for disposal of construction, demolition and packaging waste disposal requirements.

1.2 SUMMARY

- A. Section includes general requirements for single-phase and polyphase, general-purpose, horizontal, small and medium, squirrel-cage induction motors for use on ac power systems up to 600 V and installed at equipment manufacturer's factory or shipped separately by equipment manufacturer for field installation.
- B. Sustainable Building Requirements:
 - 1. The Owner requires the Contractor to implement practices and procedures to meet the project's environmental performance goals, which include achieving LEED version 4 **Certified** level Certification. Specific project goals that may impact this area of work include: use of recycled-content materials; use of locally-manufactured materials; use of low-emitting materials; construction waste recycling; and the implementation of a construction indoor air quality management plan. The Contractor shall ensure that the requirements related to these goals, as defined in the Articles below, are implemented to the fullest extent. Substitutions, or other changes to the work proposed by the Contractor or their Subcontractors, shall not be allowed if such changes compromise the aforementioned environmental goals and LEED certification.

1.3 COORDINATION

- A. Coordinate features of motors, installed units, and accessory devices to be compatible with the following:
 - 1. Motor controllers.
 - 2. Torque, speed, and horsepower requirements of the load.
 - 3. Ratings and characteristics of supply circuit and required control sequence.
 - 4. Ambient and environmental conditions of installation location.

PART 2 - PRODUCTS

2.1 GENERAL MOTOR REQUIREMENTS

- A. Comply with requirements in this Section except when stricter requirements are specified in plumbing equipment schedules or Sections.
- B. Comply with NEMA MG 1 unless otherwise indicated.
- C. Comply with IEEE 841 for severe-duty motors.

2.2 MOTOR CHARACTERISTICS

- A. Duty: Continuous duty at ambient temperature of 40 deg C and at altitude of 3300 feet (1000 m) above sea level.
- B. Capacity and Torque Characteristics: Sufficient to start, accelerate, and operate connected loads at designated speeds, at installed altitude and environment, with indicated operating sequence, and without exceeding nameplate ratings or considering service factor.

2.3 POLYPHASE MOTORS

- A. Description: NEMA MG 1, Design B, medium induction motor.
- B. Efficiency: Energy efficient, as defined in NEMA MG 1.
- C. Service Factor: 1.15.
- D. Multispeed Motors: Variable torque.
 - 1. For motors with 2:1 speed ratio, consequent pole, single winding.
 - 2. For motors with other than 2:1 speed ratio, separate winding for each speed.
- E. Multispeed Motors: Separate winding for each speed.
- F. Rotor: Random-wound, squirrel cage.
- G. Bearings: Regreasable, shielded, antifriction ball bearings suitable for radial and thrust loading.
- H. Temperature Rise: Match insulation rating.
- I. Insulation: Class F.
- J. Code Letter Designation:
 - 1. Motors 15 HP and Larger: NEMA starting Code F or Code G.
 - 2. Motors Smaller than 15 HP: Manufacturer's standard starting characteristic.
- K. Enclosure Material: Cast iron for motor frame sizes 324T and larger; rolled steel for motor frame sizes smaller than 324T.

2.4 POLYPHASE MOTORS WITH ADDITIONAL REQUIREMENTS

- A. Motors Used with Reduced-Voltage and Multispeed Controllers: Match wiring connection requirements for controller with required motor leads. Provide terminals in motor terminal box, suited to control method.
- B. Motors Used with Variable Frequency Controllers: Ratings, characteristics, and features coordinated with and approved by controller manufacturer.

1. Windings: Copper magnet wire with moisture-resistant insulation varnish, designed and tested to resist transient spikes, high frequencies, and short time rise pulses produced by pulse-width modulated inverters.
 2. Energy- and Premium-Efficient Motors: Class B temperature rise; Class F insulation.
 3. Inverter-Duty Motors: Class F temperature rise; Class H insulation.
 4. Thermal Protection: Comply with NEMA MG 1 requirements for thermally protected motors.
- C. Severe-Duty Motors: Comply with IEEE 841, with 1.15 minimum service factor.

2.5 SINGLE-PHASE MOTORS

- A. Motors larger than 1/20 hp shall be one of the following, to suit starting torque and requirements of specific motor application:
1. Permanent-split capacitor.
 2. Split phase.
 3. Capacitor start, inductor run.
 4. Capacitor start, capacitor run.
- B. Multispeed Motors: Variable-torque, permanent-split-capacitor type.
- C. Bearings: Prelubricated, antifriction ball bearings or sleeve bearings suitable for radial and thrust loading.
- D. Motors 1/20 HP and Smaller: Shaded-pole type.
- E. Thermal Protection: Internal protection to automatically open power supply circuit to motor when winding temperature exceeds a safe value calibrated to temperature rating of motor insulation. Thermal-protection device shall automatically reset when motor temperature returns to normal range.

PART 3 - EXECUTION

(Not Applicable)

END OF SECTION

This page is intentionally left blank.

SECTION 22 05 16

EXPANSION FITTINGS AND LOOPS FOR PLUMBING PIPING

PART 1 - GENERAL

1.1 RELATED DOCUMENTS

- A. Drawings and general provisions of the Contract, including General and Supplementary Conditions and Division 01 Specification Sections, apply to this Section.
- B. Section 01 81 13 "Sustainable Design Requirements – LEED v4 for Building Design & Construction – New Construction" for sustainable design requirements and detailed sustainable design submittal requirements.
- C. Section 01 74 19 "Construction and Demolition Waste Management and Disposal" for disposal of construction, demolition and packaging waste disposal requirements.

1.2 SUMMARY

- A. Section Includes:
 - 1. Rubber expansion joints.
 - 2. Flexible-hose expansion joints.
 - 3. Pipe bends and loops.
 - 4. Alignment guides and anchors.
- B. Sustainable Building Requirements:
 - 1. The Owner requires the Contractor to implement practices and procedures to meet the project's environmental performance goals, which include achieving LEED version 4 **Certified** level Certification. Specific project goals that may impact this area of work include: use of recycled-content materials; use of locally-manufactured materials; use of low-emitting materials; construction waste recycling; and the implementation of a construction indoor air quality management plan. The Contractor shall ensure that the requirements related to these goals, as defined in the Articles below, are implemented to the fullest extent. Substitutions, or other changes to the work proposed by the Contractor or their Subcontractors, shall not be allowed if such changes compromise the aforementioned environmental goals and LEED certification.

1.3 DEFINITIONS

- A. BR: Butyl rubber.
- B. Buna-N: Nitrile rubber.
- C. CR: Chlorosulfonated polyethylene synthetic rubber.
- D. CSM: Chlorosulfonyl-polyethylene rubber.
- E. EPDM: Ethylene-propylene-diene terpolymer rubber.
- F. NR: Natural rubber.

1.4 PERFORMANCE REQUIREMENTS

- A. Compatibility: Products shall be suitable for piping system fluids, materials, working pressures, and temperatures.
- B. Capability: Products shall absorb 200 percent of maximum axial movement between anchors.

1.5 SUBMITTALS

- A. Product Data: For each type of product indicated.
- B. Delegated-Design Submittal: For each anchor and alignment guide indicated to comply with performance requirements and design criteria, including analysis data signed and sealed by the qualified professional engineer responsible for their preparation.
 - 1. Design Calculations: Calculate requirements for thermal expansion of piping systems and for selecting and designing expansion joints, loops, and bends.
 - 2. Anchor Details: Detail fabrication of each anchor indicated. Show dimensions and methods of assembly and attachment to building structure.
 - 3. Alignment Guide Details: Detail field assembly and attachment to building structure.
 - 4. Schedule: Indicate type, manufacturer's number, size, material, pressure rating, end connections, and location for each expansion joint.
- C. Welding certificates.
- D. Product Certificates: For each type of pipe expansion joint, signed by product manufacturer.
- E. Maintenance Data: For pipe expansion joints to include in maintenance manuals.

1.6 QUALITY ASSURANCE

- A. Welding Qualifications: Qualify procedures and personnel according to the following:
 - 1. Steel Shapes and Plates: AWS D1.1, "Structural Welding Code - Steel."
 - 2. Welding to Piping: ASME Boiler and Pressure Vessel Code: Section IX.

PART 2 - PRODUCTS

2.1 EXPANSION JOINTS

- A. Rubber Expansion Joints: ASTM F 1123, fabric-reinforced rubber with external control rods and complying with FSA's "Technical Handbook: Non-Metallic Expansion Joints and Flexible Pipe Connectors."
 - 1. Manufacturers: Subject to compliance with requirements, provide products by one of the following:
 - a. Mason Industries, Inc.; Mercer Rubber Co.
 - b. Metraflex, Inc.
 - c. MG Piping Products Co.
 - d. Tozen America Corp.
 - 2. Spherical Type: Single or multiple spheres.

- a. Minimum Pressure and Temperature Ratings for NPS 1-1/2 to NPS 4 (DN 40 to DN 100): 150 psig (1035 kPa) at 220 deg F (104 deg C).
 - b. Minimum Pressure and Temperature Ratings for NPS 5 and NPS 6 (DN 125 and DN 150): 140 psig (966 kPa) at 200 deg F (93 deg C).
 - c. Minimum Pressure and Temperature Ratings for NPS 8 to NPS 12 (DN 200 to DN 300): 140 psig (966 kPa) at 180 deg F (82 deg C).
3. Material: Buna-N.
 4. End Connections: Full-faced, integral, steel flanges with steel retaining rings.
- B. Flexible-Hose Expansion Joints: Manufactured assembly with two flexible-metal-hose legs joined by long-radius, 180-degree return bend or center section of flexible hose; with inlet and outlet elbow fittings, corrugated-metal inner hoses, and braided outer sheaths.
1. Manufacturers: Subject to compliance with requirements, provide products by one of the following:
 - a. Flexicraft Industries.
 - b. Metraflex, Inc.
 2. Flexible-Hose Expansion Joints for Copper Piping: Copper-alloy fittings with solder- joint end connections.
 - a. NPS 2 (DN 50) and Smaller: Bronze hoses and double-braid bronze sheaths with 700 psig at 70 deg F (4830 kPa at 21 deg C) and 500 psig at 450 deg F (3450 kPa at 232 deg C) ratings.
 - b. NPS 2-1/2 to NPS 4 (DN 65 to DN 100): Stainless-steel hoses and double-braid, stainless-steel sheaths with 420 psig at 70 deg F (2890 kPa at 21 deg C) and 315 psig at 450 deg F (2170 kPa at 232 deg C) ratings.

2.2 ALIGNMENT GUIDES

- A. Description: Steel, factory fabricated, with bolted two-section outer cylinder and base for alignment of piping and two-section guiding spider for bolting to pipe.
1. Manufacturers: Subject to compliance with requirements, provide products by one of the following:
 - a. Adesco Manufacturing, LLC.
 - b. Advanced Thermal Systems, Inc.
 - c. Flexicraft Industries.
 - d. Metraflex, Inc.

2.3 MATERIALS FOR ANCHORS

- A. Steel Shapes and Plates: ASTM A 36/A 36M.
- B. Bolts and Nuts: ASME B18.10 or ASTM A 183, steel, hex head.
- C. Washers: ASTM F 844, steel, plain, flat washers.
- D. Mechanical Fasteners: Insert-wedge-type stud with expansion plug anchor for use in hardened portland cement concrete, and tension and shear capacities appropriate for application.
 1. Stud: Threaded, zinc-coated carbon steel.
 2. Expansion Plug: Zinc-coated steel.
 3. Washer and Nut: Zinc-coated steel.

- E. Chemical Fasteners: Insert-type-stud bonding system anchor for use with hardened portland cement concrete, and tension and shear capacities appropriate for application.
 - 1. Bonding Material: ASTM C 881, Type IV, Grade 3, 2-component epoxy resin suitable for surface temperature of hardened concrete where fastener is to be installed.
 - 2. Stud: ASTM A 307, zinc-coated carbon steel with continuous thread on stud, unless otherwise indicated.
 - 3. Washer and Nut: Zinc-coated steel.
- F. Concrete: Portland cement mix, 3000 psi (20.7 MPa) minimum. Comply with requirements in Division 03 Section "Cast-in-Place Concrete" for formwork, reinforcement, and concrete.
- G. Grout: ASTM C 1107, factory-mixed and -packaged, dry, hydraulic-cement, nonshrink, nonmetallic grout; suitable for interior and exterior applications.
 - 1. Properties: Nonstaining, noncorrosive, and nongaseous.
 - 2. Design Mix: 5000-psi (34.5-MPa), 28-day compressive strength.

PART 3 - EXECUTION

3.1 EXPANSION-JOINT INSTALLATION

- A. Install manufactured, nonmetallic expansion joints according to FSA's "Technical Handbook: Non-Metallic Expansion Joints and Flexible Pipe Connectors."
- B. Install expansion joints of sizes matching size of piping in which they are installed.
- C. Install alignment guides to allow expansion and to avoid end-loading and torsional stress.

3.2 PIPE BEND AND LOOP INSTALLATION

- A. Install pipe bends and loops cold-sprung in tension or compression as required to partly absorb tension or compression produced during anticipated change in temperature.
- B. Attach pipe bends and loops to anchors.
 - 1. Steel Anchors: Attach by welding. Comply with ASME B31.9 and ASME Boiler and Pressure Vessel Code: Section IX, "Welding and Brazing Qualifications."
 - 2. Concrete Anchors: Attach by fasteners. Follow fastener manufacturer's written instructions.

3.3 SWING CONNECTIONS

- A. Connect risers and branch connections to mains with at least three pipe fittings, including tee in main.

3.4 ALIGNMENT-GUIDE INSTALLATION

- A. Install guides on piping adjoining pipe expansion fittings and loops.
- B. Attach guides to pipe and secure to building structure.

3.5 ANCHOR INSTALLATION

- A. Install anchors at locations to prevent stresses from exceeding those permitted by ASME B31.9 and to prevent transfer of loading and stresses to connected equipment.
- B. Fabricate and install steel anchors by welding steel shapes, plates, and bars to piping and to structure. Comply with ASME B31.9 and AWS D1.1.
- C. Construct concrete anchors of poured-in-place concrete of dimensions indicated and include embedded fasteners.
- D. Install pipe anchors according to expansion-joint manufacturer's written instructions if expansion joints are indicated.
- E. Use grout to form flat bearing surfaces for expansion fittings, guides, and anchors installed on or in concrete.

END OF SECTION

This page is intentionally left blank.

SECTION 22 05 19

METERS AND GAGES FOR PLUMBING PIPING

PART 1 - GENERAL

1.1 RELATED DOCUMENTS

- A. Drawings and general provisions of the Contract, including General and Supplementary Conditions and Division 01 Specification Sections, apply to this Section.
- B. Section 01 81 13 "Sustainable Design Requirements – LEED v4 for Building Design & Construction – New Construction" for sustainable design requirements and detailed sustainable design submittal requirements.
- C. Section 01 74 19 "Construction and Demolition Waste Management and Disposal" for disposal of construction, demolition and packaging waste disposal requirements.

1.2 SUMMARY

- A. Section Includes:
 - 1. Thermometers.
 - 2. Gages.
 - 3. Test plugs.
- B. Related Sections:
 - 1. Division 22 Section "Facility Water Distribution Piping" for domestic and fire-protection water service meters outside the building.
 - 2. Division 22 Section "Domestic Water Piping" for domestic and fire-protection water service meters inside the building.
 - 3. Division 23 Section "Facility Natural-Gas Piping" for gas meters.
- C. Sustainable Building Requirements:
 - 1. The Owner requires the Contractor to implement practices and procedures to meet the project's environmental performance goals, which include achieving LEED version 4 **Certified** level Certification. Specific project goals that may impact this area of work include: use of recycled-content materials; use of locally-manufactured materials; use of low-emitting materials; construction waste recycling; and the implementation of a construction indoor air quality management plan. The Contractor shall ensure that the requirements related to these goals, as defined in the Articles below, are implemented to the fullest extent. Substitutions, or other changes to the work proposed by the Contractor or their Subcontractors, shall not be allowed if such changes compromise the aforementioned environmental goals and LEED certification.

1.3 DEFINITIONS

- A. CR: Chlorosulfonated polyethylene synthetic rubber.
- B. EPDM: Ethylene-propylene-diene terpolymer rubber.

1.4 SUBMITTALS

- A. Product Data: For each type of product indicated; include performance curves.
- B. Shop Drawings: Schedule for thermometers and gages indicating manufacturer's number, scale range, and location for each.
- C. Product Certificates: For each type of thermometer and gage, signed by product manufacturer.

PART 2 - PRODUCTS

2.1 METAL-CASE, LIQUID-IN-GLASS THERMOMETERS

- A. Manufacturers: Subject to compliance with requirements, provide products by one of the following:
 - 1. Terrice, H. O. Co.
 - 2. Weiss Instruments, Inc.
 - 3. Weksler Instruments Operating Unit; Dresser Industries; Instrument Div.
- B. Case: Die-cast aluminum ,9 inches (229 mm) long.
- C. Tube: Red or blue reading, organic-liquid filled, with magnifying lens.
- D. Tube Background: Satin-faced, nonreflective aluminum with permanently etched scale markings.
- E. Window: Glass.
- F. Connector: Adjustable type, 180 degrees in vertical plane, 360 degrees in horizontal plane, with locking device .
- G. Stem: Copper-plated steel, aluminum, or brass for thermowell installation and of length to suit installation.
- H. Accuracy: Plus or minus 1 percent of range or plus or minus 1 scale division to maximum of 1.5 percent of range.

2.2 THERMOWELLS

- A. Manufacturers: Subject to compliance with requirements, provide products by one of the following:
 - 1. AMETEK, Inc.; U.S. Gauge Div.
 - 2. Ashcroft Commercial Instrument Operations; Dresser Industries; Instrument Div.
 - 3. Ernst Gage Co.
 - 4. Terrice, H. O. Co.
 - 5. Weiss Instruments, Inc.
 - 6. Weksler Instruments Operating Unit; Dresser Industries; Instrument Div.
 - 7. WIKA Instrument Corporation.
- B. Manufacturers: Same as manufacturer of thermometer being used.
- C. Description: Pressure-tight, socket-type metal fitting made for insertion into piping and of type, diameter, and length required to hold thermometer.

2.3 PRESSURE GAGES

- A. Manufacturers: Subject to compliance with requirements, provide products by one of the following:
 - 1. AMETEK, Inc.; U.S. Gauge Div.
 - 2. Ashcroft Commercial Instrument Operations; Dresser Industries; Instrument Div.
 - 3. Ernst Gage Co.
 - 4. Trerice, H. O. Co.
 - 5. Weiss Instruments, Inc.
 - 6. Weksler Instruments Operating Unit; Dresser Industries; Instrument Div.
 - 7. WIKA Instrument Corporation.

- B. Direct-Mounting, Dial-Type Pressure Gages: Indicating-dial type complying with ASME B40.100.
 - 1. Case: Dry or Liquid-filled type, drawn steel or cast aluminum ,6-inch (152-mm) diameter.
 - 2. Pressure-Element Assembly: Bourdon tube, unless otherwise indicated.
 - 3. Pressure Connection: Brass, NPS 1/4 (DN 8), bottom-outlet type unless back-outlet type is indicated.
 - 4. Movement: Mechanical, with link to pressure element and connection to pointer.
 - 5. Dial: Satin-faced, nonreflective aluminum with permanently etched scale markings.
 - 6. Pointer: Red metal.
 - 7. Window: Glass.
 - 8. Ring: Stainless steel .
 - 9. Accuracy: Grade A, plus or minus 1 percent of middle half scale.
 - 10. Vacuum-Pressure Range: 30-in. Hg of vacuum to 15 psig of pressure (100 kPa of vacuum to 103 kPa of pressure).
 - 11. Range for Fluids under Pressure: Two times operating pressure.

- C. Pressure-Gage Fittings:
 - 1. Valves: NPS 1/4 (DN 8) brass or stainless-steel needle type.
 - 2. Snubbers: ASME B40.5, NPS 1/4 (DN 8) brass bushing with corrosion-resistant, porous-metal disc of material suitable for system fluid and working pressure.

PART 3 - EXECUTION

3.1 THERMOMETER APPLICATIONS

- A. Install liquid-in-glass thermometers in the outlet of each domestic, hot-water storage tank at each hot water circulating branch, adjacent to hot water circulating pumps and at the most remote hot water outlet..

- B. Provide the following temperature ranges for thermometers:
 - 1. Domestic Hot Water: 30 to 180 deg F, with 2-degree scale divisions (Minus 1 to plus 82 deg C, with 1-degree scale divisions) .
 - 2. Domestic Cold Water: 0 to 100 deg F, with 2-degree scale divisions (Minus 18 to plus 38 deg C, with 1-degree scale divisions) .

3.2 GAGE APPLICATIONS

- A. Install dry-case-type pressure gages for discharge of each pressure-reducing valve.
- B. Install liquid-filled-case-type pressure gages at suction and discharge of each pump.

3.3 INSTALLATIONS

- A. Install direct-mounting thermometers and adjust vertical and tilted positions to be visible from the floor.
- B. Install remote-mounting dial thermometers on panel, with tubing connecting panel and thermometer bulb supported to prevent kinks. Use minimum tubing length.
- C. Install thermowells with socket extending to center of pipe and in vertical position in piping tees where thermometers are indicated.
- D. Install direct-mounting pressure gages in piping tees with pressure gage located on pipe at most readable position.
- E. Install remote-mounting pressure gages on panel.
- F. Install needle-valve and snubber fitting in piping for each pressure gage.
- G. Install test plugs in tees in piping.
- H. Install permanent indicators on walls or brackets in accessible and readable positions.
- I. Install connection fittings for attachment to portable indicators in accessible locations.
- J. Install thermometers and gages adjacent to machines and equipment to allow service and maintenance for thermometers, gages, machines, and equipment.
- K. Adjust faces of thermometers and gages to proper angle for best visibility.

END OF SECTION

SECTION 22 05 23

GENERAL-DUTY VALVES FOR PLUMBING PIPING

PART 1 - GENERAL

1.1 RELATED DOCUMENTS

- A. Drawings and general provisions of the Contract, including General and Supplementary Conditions and Division 01 Specification Sections, apply to this Section.
- B. Section 01 81 13 "Sustainable Design Requirements – LEED v4 for Building Design & Construction – New Construction" for sustainable design requirements and detailed sustainable design submittal requirements.
- C. Section 01 74 19 "Construction and Demolition Waste Management and Disposal" for disposal of construction, demolition and packaging waste disposal requirements.

1.2 SUMMARY

- A. Section Includes:
 - 1. Bronze lift check valves.
 - 2. Bronze swing check valves.
 - 3. Iron swing check valves.
 - 4. Bronze gate valves.
 - 5. Iron gate valves.
 - 6. Bronze globe valves.
- B. Related Sections:
 - 1. Division 22 plumbing piping Sections for specialty valves applicable to those Sections only.
 - 2. Division 22 Section "Identification for Plumbing Piping and Equipment" for valve tags and schedules.
 - 3. Division 33 water distribution piping Sections for general-duty and specialty valves for site construction piping.
- C. Section 01 81 13 "Sustainable Design Requirements – LEED v4 for Building Design & Construction – New Construction" for sustainable design requirements and detailed sustainable design submittal requirements.
- D. Section 01 74 19 "Construction and Demolition Waste Management and Disposal" for disposal of construction, demolition and packaging waste disposal requirements.

1.3 DEFINITIONS

- A. CWP: Cold working pressure.
- B. EPDM: Ethylene propylene copolymer rubber.
- C. NBR: Acrylonitrile-butadiene, Buna-N, or nitrile rubber.

- D. NRS: Nonrising stem.
- E. OS&Y: Outside screw and yoke.
- F. RS: Rising stem.
- G. SWP: Steam working pressure.

1.4 SUBMITTALS

- A. Product Data: For each type of valve indicated.

1.5 QUALITY ASSURANCE

- A. Source Limitations for Valves: Obtain each type of valve from single source from single manufacturer.
- B. ASME Compliance:
 - 1. ASME B16.10 and ASME B16.34 for ferrous valve dimensions and design criteria.
 - 2. ASME B31.1 for power piping valves.
 - 3. ASME B31.9 for building services piping valves.
- C. NSF Compliance: NSF 61 for valve materials for potable-water service.

1.6 DELIVERY, STORAGE, AND HANDLING

- A. Prepare valves for shipping as follows:
 - 1. Protect internal parts against rust and corrosion.
 - 2. Protect threads, flange faces, grooves, and weld ends.
 - 3. Set angle, gate, and globe valves closed to prevent rattling.
 - 4. Set ball and plug valves open to minimize exposure of functional surfaces.
 - 5. Set butterfly valves closed or slightly open.
 - 6. Block check valves in either closed or open position.
- B. Use the following precautions during storage:
 - 1. Maintain valve end protection.
 - 2. Store valves indoors and maintain at higher than ambient dew point temperature. If outdoor storage is necessary, store valves off the ground in watertight enclosures.
- C. Use sling to handle large valves; rig sling to avoid damage to exposed parts. Do not use handwheels or stems as lifting or rigging points.
- D. PEX Valves
 - 1. General: Comply with product requirement section.
 - 2. Delivery: Deliver materials in manufacturers original, unopened, undamaged containers

PART 2 - PRODUCTS

2.1 GENERAL REQUIREMENTS FOR VALVES

- A. Refer to valve schedule articles for applications of valves.

- B. Valve Pressure and Temperature Ratings: Not less than indicated and as required for system pressures and temperatures.
- C. Valve Sizes: Same as upstream piping unless otherwise indicated.
- D. Valve Actuator Types:
 - 1. Handwheel: For valves other than quarter-turn types.
 - 2. Handlever: For quarter-turn valves NPS 6 (DN 150) and smaller.
- E. Valves in Insulated Piping: With 2-inch (50-mm) stem extensions and the following features:
 - 1. Gate Valves: With rising stem.
 - 2. Ball Valves: With extended operating handle of non-thermal-conductive material, and protective sleeve that allows operation of valve without breaking the vapor seal or disturbing insulation.
- F. Valve-End Connections:
 - 1. Flanged: With flanges according to ASME B16.1 for iron valves.
 - 2. Grooved: With grooves according to AWWA C606.
 - 3. Solder Joint: With sockets according to ASME B16.18.
 - 4. Threaded: With threads according to ASME B1.20.1.
- G. Valve Bypass and Drain Connections: MSS SP-45.

2.2 BRONZE BALL VALVES

- A. Two-Piece, Full-Port, Bronze Ball Valves with Stainless-Steel Trim:
 - 1. Manufacturers: Subject to compliance with requirements, provide products by one of the following:
 - a. Conbraco Industries, Inc.; Apollo Valves.
 - b. NIBCO INC.
 - c. Watts Regulator Co.; a division of Watts Water Technologies, Inc.
 - 2. Description:
 - a. Standard: MSS SP-110.
 - b. SWP Rating: 150 psig (1035 kPa).
 - c. CWP Rating: 600 psig (4140 kPa).
 - d. Body Design: Two piece.
 - e. Body Material: Bronze.
 - f. Ends: Threaded.
 - g. Seats: PTFE or TFE.
 - h. Stem: Stainless steel.
 - i. Ball: Stainless steel, vented.
 - j. Port: Full.

2.3 BRONZE LIFT CHECK VALVES

- A. Class 125, Lift Check Valves with Nonmetallic Disc:
 - 1. Manufacturers: Subject to compliance with requirements, provide products by one of the following:
 - a. Milwaukee Valve Company.
 - b. NIBCO INC.
 - c. Watts Regulator Co.; a division of Watts Water Technologies, Inc.
 - 2. Description:
 - a. Standard: MSS SP-80, Type 2.
 - b. CWP Rating: 200 psig (1380 kPa).

- c. Body Design: Vertical flow.
- d. Body Material: ASTM B 61 or ASTM B 62, bronze.
- e. Ends: Threaded.
- f. Disc: NBR, PTFE, or TFE.

2.4 BRONZE SWING CHECK VALVES

- A. Class 125, Bronze Swing Check Valves with Nonmetallic Disc:
 - 1. Manufacturers: Subject to compliance with requirements, provide products by one of the following:
 - a. Milwaukee Valve Company.
 - b. NIBCO INC.
 - c. Watts Regulator Co.; a division of Watts Water Technologies, Inc.
 - 2. Description:
 - a. Standard: MSS SP-80, Type 4.
 - b. CWP Rating: 200 psig (1380 kPa).
 - c. Body Design: Horizontal flow.
 - d. Body Material: ASTM B 62, bronze.
 - e. Ends: Threaded.
 - f. Disc: PTFE or TFE.
- B. Class 150, Bronze Swing Check Valves with Nonmetallic Disc:
 - 1. Manufacturers: Subject to compliance with requirements, provide products by one of the following:
 - a. Milwaukee Valve Company.
 - b. NIBCO INC.
 - c. Watts Regulator Co.; a division of Watts Water Technologies, Inc.
 - 2. Description:
 - a. Standard: MSS SP-80, Type 4.
 - b. CWP Rating: 300 psig (2070 kPa).
 - c. Body Design: Horizontal flow.
 - d. Body Material: ASTM B 62, bronze.
 - e. Ends: Threaded.
 - f. Disc: PTFE or TFE.

2.5 BRONZE GATE VALVES

- A. Class 125, RS Bronze Gate Valves:
 - 1. Manufacturers: Subject to compliance with requirements, provide products by one of the following:
 - a. Milwaukee Valve Company.
 - b. NIBCO INC.
 - c. Watts Regulator Co.; a division of Watts Water Technologies, Inc.
 - 2. Description:
 - a. Standard: MSS SP-80, Type 2.
 - b. CWP Rating: 200 psig (1380 kPa).
 - c. Body Material: ASTM B 62, bronze with integral seat and screw-in bonnet.
 - d. Ends: Threaded or solder joint.
 - e. Stem: Bronze.
 - f. Disc: Solid wedge; bronze.
 - g. Packing: Asbestos free.
 - h. Handwheel: Malleable iron, bronze, or aluminum.

- B. Class 150, RS Bronze Gate Valves:
 - 1. Manufacturers: Subject to compliance with requirements, provide products by one of the following:
 - a. Milwaukee Valve Company.
 - b. NIBCO INC.
 - c. Watts Regulator Co.; a division of Watts Water Technologies, Inc.
 - 2. Description:
 - a. Standard: MSS SP-80, Type 2.
 - b. CWP Rating: 300 psig (2070 kPa).
 - c. Body Material: ASTM B 62, bronze with integral seat and union-ring bonnet.
 - d. Ends: Threaded.
 - e. Stem: Bronze.
 - f. Disc: Solid wedge; bronze.
 - g. Packing: Asbestos free.
 - h. Handwheel: Malleable iron.

2.6 IRON GATE VALVES

- A. Class 125, OS&Y, Iron Gate Valves:
 - 1. Manufacturers: Subject to compliance with requirements, provide products by one of the following:
 - a. Milwaukee Valve Company.
 - b. NIBCO INC.
 - c. Watts Regulator Co.; a division of Watts Water Technologies, Inc.
 - 2. Description:
 - a. Standard: MSS SP-70, Type I.
 - b. CWP Rating: 200 psig (1380 kPa).
 - c. Body Material: ASTM A 126, gray iron with bolted bonnet.
 - d. Ends: Flanged.
 - e. Trim: Bronze.
 - f. Disc: Solid wedge.
 - g. Packing and Gasket: Asbestos free.
- B. Class 250, OS&Y, Iron Gate Valves:
 - 1. Manufacturers: Subject to compliance with requirements, provide products by one of the following:
 - a. Milwaukee Valve Company.
 - b. NIBCO INC.
 - c. Watts Regulator Co.; a division of Watts Water Technologies, Inc.
 - 2. Description:
 - a. Standard: MSS SP-70, Type I.
 - b. CWP Rating: 500 psig (3450 kPa).
 - c. Body Material: ASTM A 126, gray iron with bolted bonnet.
 - d. Ends: Flanged.
 - e. Trim: Bronze.
 - f. Disc: Solid wedge.
 - g. Packing and Gasket: Asbestos free.

2.7 BRONZE GLOBE VALVES

- A. Class 125, Bronze Globe Valves with Nonmetallic Disc:

1. Manufacturers: Subject to compliance with requirements, provide products by one of the following:
 - a. Milwaukee Valve Company.
 - b. Watts Regulator Co.; a division of Watts Water Technologies, Inc.
 - c. NIBCO INC.
 2. Description:
 - a. Standard: MSS SP-80, Type 2.
 - b. CWP Rating: 200 psig (1380 kPa).
 - c. Body Material: ASTM B 62, bronze with integral seat and screw-in bonnet.
 - d. Ends: Threaded.
 - e. Stem: Bronze.
 - f. Disc: PTFE or TFE.
 - g. Packing: Asbestos free.
 - h. Handwheel: Malleable iron.
- B. Class 150, Bronze Globe Valves with Nonmetallic Disc:
1. Manufacturers: Subject to compliance with requirements, provide products by one of the following:
 - a. NIBCO INC.
 - b. Milwaukee Valve Company.
 - c. Watts Regulator Co.; a division of Watts Water Technologies, Inc.
 2. Description:
 - a. Standard: MSS SP-80, Type 2.
 - b. CWP Rating: 300 psig (2070 kPa).
 - c. Body Material: ASTM B 62, bronze with integral seat and union-ring bonnet.
 - d. Ends: Threaded.
 - e. Stem: Bronze.
 - f. Disc: PTFE or TFE.
 - g. Packing: Asbestos free.
 - h. Handwheel: Malleable iron.

PART 3 - EXECUTION

3.1 EXAMINATION

- A. Examine valve interior for cleanliness, freedom from foreign matter, and corrosion. Remove special packing materials, such as blocks, used to prevent disc movement during shipping and handling.
- B. Operate valves in positions from fully open to fully closed. Examine guides and seats made accessible by such operations.
- C. Examine threads on valve and mating pipe for form and cleanliness.
- D. Examine mating flange faces for conditions that might cause leakage. Check bolting for proper size, length, and material. Verify that gasket is of proper size, that its material composition is suitable for service, and that it is free from defects and damage.
- E. Do not attempt to repair defective valves; replace with new valves.

3.2 VALVE INSTALLATION

- A. Install valves with unions or flanges at each piece of equipment arranged to allow service, maintenance, and equipment removal without system shutdown.
- B. Locate valves for easy access and provide separate support where necessary.
- C. Install valves in horizontal piping with stem at or above center of pipe.
- D. Install valves in position to allow full stem movement.
- E. Install chainwheels on operators for gate valves NPS 4 (DN 100) and larger and more than 84 inches (2400 mm) above floor. Extend chains to 60 inches (1520 mm) above finished floor.
- F. Install check valves for proper direction of flow and as follows:
 - 1. Swing Check Valves: In horizontal position with hinge pin level.

3.3 ADJUSTING

- A. Adjust or replace valve packing after piping systems have been tested and put into service but before final adjusting and balancing. Replace valves if persistent leaking occurs.

3.4 GENERAL REQUIREMENTS FOR VALVE APPLICATIONS

- A. If valve applications are not indicated, use the following:
 - 1. Shutoff Service: Ball, butterfly, or gate valves.
 - 2. Throttling Service: Globe valves.
 - 3. Pump-Discharge Check Valves:
 - a. NPS 2 (DN 50) and Smaller: Bronze swing check valves with disc.
 - b. NPS 2-1/2 (DN 65) and Larger for Domestic Water: Iron swing check valves with lever and weight or with spring or iron, center-guided, resilient-seat check valves.
 - c. NPS 2-1/2 (DN 65) and Larger for Sanitary Waste and Storm Drainage: Iron swing check valves with lever and weight or spring.
- B. If valves with specified SWP classes or CWP ratings are not available, the same types of valves with higher SWP classes or CWP ratings may be substituted.
- C. Select valves, except wafer types, with the following end connections:
 - 1. For Copper Tubing, NPS 2 (DN 50) and Smaller: Threaded ends except where solder-joint valve-end option is indicated in valve schedules below.
 - 2. For Copper Tubing, NPS 2-1/2 to NPS 4 (DN 65 to DN 100): Flanged ends except where threaded valve-end option is indicated in valve schedules below.
 - 3. For Copper Tubing, NPS 5 (DN 125) and Larger: Flanged ends.
 - 4. For Steel Piping, NPS 2 (DN 50) and Smaller: Threaded ends.
 - 5. For Steel Piping, NPS 2-1/2 to NPS 4 (DN 65 to DN 100): Flanged ends except where threaded valve-end option is indicated in valve schedules below.
 - 6. For Steel Piping, NPS 5 (DN 125) and Larger: Flanged ends.
 - 7. For Grooved-End Copper Tubing and Steel Piping: Valve ends may be grooved.

3.5 LOW-PRESSURE, COMPRESSED-AIR VALVE SCHEDULE (150 PSIG (1035 kPa) OR LESS)

- A. Pipe NPS 2 (DN 50) and Smaller:
1. Bronze Valves: May be provided with solder-joint ends instead of threaded ends.
 2. Ball Valves: Two piece, full port, bronze with bronze trim.
 3. Bronze Lift Check Valves: Class 125, nonmetallic disc.
 4. Bronze Swing Check Valves: Class 150, nonmetallic disc.
 5. Bronze Gate Valves: Class 150, RS.

3.6 DOMESTIC, HOT- AND COLD-WATER VALVE SCHEDULE

- A. Pipe NPS 2 (DN 50) and Smaller:
1. Bronze Valves: May be provided with solder-joint ends instead of threaded ends.
 2. Bronze Angle Valves: Class 150, nonmetallic disc.
 3. Ball Valves: Two piece, full port, bronze with stainless-steel trim.
 4. Bronze Swing Check Valves: Class 150, nonmetallic disc.
 5. Bronze Gate Valves: Class 150, RS.
 6. Bronze Globe Valves: Class 150, nonmetallic disc.
- B. Pipe NPS 2-1/2 (DN 65) and Larger:
1. Iron Valves, NPS 2-1/2 to NPS 4 (DN 65 to DN 100): May be provided with threaded ends instead of flanged ends.
 2. Iron Swing Check Valves: Class 250, metal seats.
 3. Iron, Grooved-End Swing Check Valves: 300 CWP.
 4. Iron, Center-Guided Check Valves: Class 125 Class 150 Class 250 Class 300, globe, resilient seat.
 5. Iron Gate Valves: Class 125 Class 250, .

3.7 SANITARY-WASTE AND STORM-DRAINAGE VALVE SCHEDULE

- A. Pipe NPS 2 (DN 50) and Smaller:
1. Bronze Valves: May be provided with solder-joint ends instead of threaded ends.
 2. Ball Valves: Two piece, full port, bronze with stainless-steel trim.
 3. Bronze Swing Check Valves: Class 125, nonmetallic disc.
 4. Bronze Gate Valves: Class 125, RS.
- B. Pipe NPS 2-1/2 (DN 65) and Larger:
1. Iron Valves, NPS 2-1/2 to NPS 4 (DN 65 to DN 100): May be provided with threaded ends instead of flanged ends.
 2. Iron Swing Check Valves: Class 125, metal seats.
 3. Iron Swing Check Valves with Closure Control: Class 125, lever and spring.
 4. Iron, Grooved-End Swing Check Valves: 300 CWP.
 5. Iron Gate Valves: Class 125, OS&Y.

END OF SECTION

Section 22 05 29

HANGERS AND SUPPORTS FOR PLUMBING PIPING AND EQUIPMENT

PART 1 - GENERAL

1.1 RELATED DOCUMENTS

- A. Drawings and general provisions of the Contract, including General and Supplementary Conditions and Division 01 Specification Sections, apply to this Section.
- B. Section 01 81 13 "Sustainable Design Requirements – LEED v4 for Building Design & Construction – New Construction" for sustainable design requirements and detailed sustainable design submittal requirements.
- C. Section 01 74 19 "Construction and Demolition Waste Management and Disposal" for disposal of construction, demolition and packaging waste disposal requirements.

1.2 SUMMARY

- A. This Section includes the following hangers and supports for plumbing system piping and equipment:
 - 1. Steel pipe hangers and supports.
 - 2. Trapeze pipe hangers.
 - 3. Metal framing systems.
 - 4. Thermal-hanger shield inserts.
 - 5. Fastener systems.
 - 6. Pipe stands.
 - 7. Pipe positioning systems.
 - 8. Equipment supports.
- B. Related Sections include the following:
 - 1. Division 05 Section "Metal Fabrications" for structural-steel shapes and plates for trapeze hangers for pipe and equipment supports.
 - 2. Division 21 Section "Water-Based Fire-Suppression Systems" for pipe hangers for fire-suppression piping.
 - 3. Division 22 Section "Expansion Fittings and Loops for Plumbing Piping" for pipe guides and anchors.
 - 4. Division 22 Section "Vibration and Seismic Controls for Plumbing Piping and Equipment" for vibration isolation devices.
- C. Sustainable Building Requirements:
 - 1. The Owner requires the Contractor to implement practices and procedures to meet the project's environmental performance goals, which include achieving LEED version 4 **Certified** level Certification. Specific project goals that may impact this area of work include: use of recycled-content materials; use of locally-manufactured materials; use of low-emitting materials; construction waste recycling; and the implementation of a construction indoor air quality management plan. The Contractor shall ensure that the requirements related to these goals, as defined in the Articles below, are implemented to the fullest

extent. Substitutions, or other changes to the work proposed by the Contractor or their Subcontractors, shall not be allowed if such changes compromise the aforementioned environmental goals and LEED certification.

1.3 DEFINITIONS

- A. MSS: Manufacturers Standardization Society for The Valve and Fittings Industry Inc.
- B. Terminology: As defined in MSS SP-90, "Guidelines on Terminology for Pipe Hangers and Supports."

1.4 PERFORMANCE REQUIREMENTS

- A. Design supports for multiple pipes, including pipe stands, capable of supporting combined weight of supported systems, system contents, and test water.
- B. Design equipment supports capable of supporting combined operating weight of supported equipment and connected systems and components.
- C. Design seismic-restraint hangers and supports for piping and equipment.

1.5 SUBMITTALS

- A. Product Data: For the following:
 - 1. Steel pipe hangers and supports.
 - 2. Fiberglass pipe hangers.
 - 3. Thermal-hanger shield inserts.
 - 4. Powder-actuated fastener systems.
 - 5. Pipe positioning systems.
- B. Shop Drawings: Show fabrication and installation details and include calculations for the following:
 - 1. Trapeze pipe hangers. Include Product Data for components.
 - 2. Metal framing systems. Include Product Data for components.
 - 3. Pipe stands. Include Product Data for components.
 - 4. Equipment supports.
- C. Welding certificates.

1.6 QUALITY ASSURANCE

- A. Welding: Qualify procedures and personnel according to the following:
 - 1. AWS D1.1, "Structural Welding Code--Steel."
 - 2. AWS D1.2, "Structural Welding Code--Aluminum."
 - 3. AWS D1.4, "Structural Welding Code--Reinforcing Steel."
 - 4. ASME Boiler and Pressure Vessel Code: Section IX.

PART 2 - PRODUCTS

2.1 MANUFACTURERS

- A. In other Part 2 articles where titles below introduce lists, the following requirements apply to product selection:

1. Available Manufacturers: Subject to compliance with requirements, manufacturers offering products that may be incorporated into the Work include, but are not limited to, manufacturers specified.
2. Manufacturers: Subject to compliance with requirements, provide products by one of the manufacturers specified.

2.2 STEEL PIPE HANGERS AND SUPPORTS

- A. Description: MSS SP-58, Types 1 through 58, factory-fabricated components. Refer to Part 3 "Hanger and Support Applications" Article for where to use specific hanger and support types.
- B. Manufacturers:
 1. B-Line Systems, Inc.; a division of Cooper Industries.
 2. Carpenter & Paterson, Inc.
 3. Grinnell Corp.
- C. Galvanized, Metallic Coatings: Pregalvanized or hot dipped.
- D. Nonmetallic Coatings: Plastic coating, jacket, or liner.
- E. Padded Hangers: Hanger with fiberglass or other pipe insulation pad or cushion for support of bearing surface of piping.

2.3 TRAPEZE PIPE HANGERS

- A. Description: MSS SP-69, Type 59, shop- or field-fabricated pipe-support assembly made from structural-steel shapes with MSS SP-58 hanger rods, nuts, saddles, and U-bolts.

2.4 METAL FRAMING SYSTEMS

- A. Description: MFMA-3, shop- or field-fabricated pipe-support assembly made of steel channels and other components.
- B. Manufacturers:
 1. B-Line Systems, Inc.; a division of Cooper Industries.
 2. Power-Strut Div.; Tyco International, Ltd.
 3. Unistrut Corp.; Tyco International, Ltd.
- C. Coatings: Manufacturer's standard finish unless bare metal surfaces are indicated.
- D. Nonmetallic Coatings: Plastic coating, jacket, or liner.

2.5 THERMAL-HANGER SHIELD INSERTS

- A. Description: 100-psig- (690-kPa-) minimum, compressive-strength insulation insert encased in sheet metal shield.
- B. Manufacturers:
 1. Carpenter & Paterson, Inc.
 2. ERICO/Michigan Hanger Co.
 3. Pipe Shields, Inc.
- C. Insulation-Insert Material for Cold Piping: Water-repellent treated, ASTM C 533, Type I calcium silicate or ASTM C 552, Type II cellular glass with vapor barrier.

- D. Insulation-Insert Material for Hot Piping: Water-repellent treated, ASTM C 533, Type I calcium silicate or ASTM C 552, Type II cellular glass.
- E. For Trapeze or Clamped Systems: Insert and shield shall cover entire circumference of pipe.
- F. For Clevis or Band Hangers: Insert and shield shall cover lower 180 degrees of pipe.
- G. Insert Length: Extend 2 inches (50 mm) beyond sheet metal shield for piping operating below ambient air temperature.

2.6 FASTENER SYSTEMS

- A. Powder-Actuated Fasteners: Threaded-steel stud, for use in hardened portland cement concrete with pull-out, tension, and shear capacities appropriate for supported loads and building materials where used.
 - 1. Manufacturers:
 - a. Hilti, Inc.
 - b. ITW Ramset/Red Head.
 - c. Powers Fasteners.
- B. Mechanical-Expansion Anchors: Insert-wedge-type stainless steel, for use in hardened portland cement concrete with pull-out, tension, and shear capacities appropriate for supported loads and building materials where used.
 - 1. Manufacturers:
 - a. B-Line Systems, Inc.; a division of Cooper Industries.
 - b. Hilti, Inc.
 - c. ITW Ramset/Red Head.

2.7 PIPE STAND FABRICATION

- A. Pipe Stands, General: Shop or field-fabricated assemblies made of manufactured corrosion-resistant components to support roof-mounted piping.
- B. Compact Pipe Stand: One-piece plastic unit with integral-rod-roller, pipe clamps, or V-shaped cradle to support pipe, for roof installation without membrane penetration.
 - 1. Manufacturers:
 - a. ERICO/Michigan Hanger Co.
 - b. MIRO Industries.
- C. Low-Type, Single-Pipe Stand: One-stainless-steel base unit with plastic roller, for roof installation without membrane penetration.
 - 1. Manufacturers:
 - a. MIRO Industries.
 - b. ERICO/Michigan Hanger Co.
- D. High-Type, Single-Pipe Stand: Assembly of base, vertical and horizontal members, and pipe support, for roof installation without membrane penetration.
 - 1. Manufacturers:
 - a. ERICO/Michigan Hanger Co.
 - b. MIRO Industries.
 - c. Portable Pipe Hangers.
 - 2. Base: Stainless steel.

3. Vertical Members: Two or more cadmium-plated-steel or stainless-steel, continuous-thread rods.
 4. Horizontal Member: Cadmium-plated-steel or stainless-steel rod with plastic or stainless-steel, roller-type pipe support.
- E. High-Type, Multiple-Pipe Stand: Assembly of bases, vertical and horizontal members, and pipe supports, for roof installation without membrane penetration.
1. Manufacturers:
 - a. Portable Pipe Hangers.
 - b. MIRO Industries.
 - c. ERICO/Michigan Hanger Co.
 2. Bases: One or more plastic.
 3. Vertical Members: Two or more protective-coated-steel channels.
 4. Horizontal Member: Protective-coated-steel channel.
 5. Pipe Supports: Galvanized-steel, clevis-type pipe hangers.
- F. Curb-Mounting-Type Pipe Stands: Shop- or field-fabricated pipe support made from structural-steel shape, continuous-thread rods, and rollers for mounting on permanent stationary roof curb.

2.8 PIPE POSITIONING SYSTEMS

- A. Description: IAPMO PS 42, system of metal brackets, clips, and straps for positioning piping in pipe spaces for plumbing fixtures for commercial applications.
- B. Manufacturers:
1. C & S Mfg. Corp.
 2. HOLDRITE Corp.; Hubbard Enterprises.
 3. Samco Stamping, Inc.

2.9 EQUIPMENT SUPPORTS

- A. Description: Welded, shop- or field-fabricated equipment support made from structural-steel shapes.

2.10 MISCELLANEOUS MATERIALS

- A. Structural Steel: ASTM A 36/A 36M, steel plates, shapes, and bars; black and galvanized.
- B. Grout: ASTM C 1107, factory-mixed and -packaged, dry, hydraulic-cement, nonshrink and nonmetallic grout; suitable for interior and exterior applications.
1. Properties: Nonstaining, noncorrosive, and nongaseous.
 2. Design Mix: 5000-psi (34.5-MPa), 28-day compressive strength.

PART 3 - EXECUTION

3.1 HANGER AND SUPPORT APPLICATIONS

- A. Specific hanger and support requirements are specified in Sections specifying piping systems and equipment.

- B. Comply with MSS SP-69 for pipe hanger selections and applications that are not specified in piping system Sections.
- C. Use hangers and supports with galvanized, metallic coatings for piping and equipment that will not have field-applied finish.
- D. Use nonmetallic coatings on attachments for electrolytic protection where attachments are in direct contact with copper tubing.
- E. Use padded hangers for piping that is subject to scratching.
- F. Horizontal-Piping Hangers and Supports: Unless otherwise indicated and except as specified in piping system Sections, install the following types:
 - 1. Adjustable, Steel Clevis Hangers (MSS Type 1): For suspension of noninsulated or insulated stationary pipes, NPS 1/2 to NPS 30 (DN 15 to DN 750).
 - 2. Yoke-Type Pipe Clamps (MSS Type 2): For suspension of 120 to 450 deg F (49 to 232 deg C) pipes, NPS 4 to NPS 16 (DN 100 to DN 400), requiring up to 4 inches (100 mm) of insulation.
 - 3. Carbon- or Alloy-Steel, Double-Bolt Pipe Clamps (MSS Type 3): For suspension of pipes, NPS 3/4 to NPS 24 (DN 20 to DN 600), requiring clamp flexibility and up to 4 inches (100 mm) of insulation.
 - 4. Steel Pipe Clamps (MSS Type 4): For suspension of cold and hot pipes, NPS 1/2 to NPS 24 (DN 15 to DN 600), if little or no insulation is required.
 - 5. Pipe Hangers (MSS Type 5): For suspension of pipes, NPS 1/2 to NPS 4 (DN 15 to DN 100), to allow off-center closure for hanger installation before pipe erection.
 - 6. Adjustable, Swivel Split- or Solid-Ring Hangers (MSS Type 6): For suspension of noninsulated stationary pipes, NPS 3/4 to NPS 8 (DN 20 to DN 200).
 - 7. Adjustable, Steel Band Hangers (MSS Type 7): For suspension of noninsulated stationary pipes, NPS 1/2 to NPS 8 (DN 15 to DN 200).
 - 8. Adjustable Band Hangers (MSS Type 9): For suspension of noninsulated stationary pipes, NPS 1/2 to NPS 8 (DN 15 to DN 200).
 - 9. Adjustable, Swivel-Ring Band Hangers (MSS Type 10): For suspension of noninsulated stationary pipes, NPS 1/2 to NPS 2 (DN 15 to DN 50).
 - 10. Split Pipe-Ring with or without Turnbuckle-Adjustment Hangers (MSS Type 11): For suspension of noninsulated stationary pipes, NPS 3/8 to NPS 8 (DN 10 to DN 200).
 - 11. Extension Hinged or 2-Bolt Split Pipe Clamps (MSS Type 12): For suspension of noninsulated stationary pipes, NPS 3/8 to NPS 3 (DN 10 to DN 80).
 - 12. U-Bolts (MSS Type 24): For support of heavy pipes, NPS 1/2 to NPS 30 (DN 15 to DN 750).
 - 13. Clips (MSS Type 26): For support of insulated pipes not subject to expansion or contraction.
 - 14. Pipe Saddle Supports (MSS Type 36): For support of pipes, NPS 4 to NPS 36 (DN 100 to DN 900), with steel pipe base stanchion support and cast-iron floor flange.
 - 15. Pipe Stanchion Saddles (MSS Type 37): For support of pipes, NPS 4 to NPS 36 (DN 100 to DN 900), with steel pipe base stanchion support and cast-iron floor flange and with U-bolt to retain pipe.
 - 16. Adjustable, Pipe Saddle Supports (MSS Type 38): For stanchion-type support for pipes, NPS 2-1/2 to NPS 36 (DN 65 to DN 900), if vertical adjustment is required, with steel pipe base stanchion support and cast-iron floor flange.

17. Single Pipe Rolls (MSS Type 41): For suspension of pipes, NPS 1 to NPS 30 (DN 25 to DN 750), from 2 rods if longitudinal movement caused by expansion and contraction might occur.
 18. Adjustable Roller Hangers (MSS Type 43): For suspension of pipes, NPS 2-1/2 to NPS 20 (DN 65 to DN 500), from single rod if horizontal movement caused by expansion and contraction might occur.
 19. Complete Pipe Rolls (MSS Type 44): For support of pipes, NPS 2 to NPS 42 (DN 50 to DN 1050), if longitudinal movement caused by expansion and contraction might occur but vertical adjustment is not necessary.
 20. Pipe Roll and Plate Units (MSS Type 45): For support of pipes, NPS 2 to NPS 24 (DN 50 to DN 600), if small horizontal movement caused by expansion and contraction might occur and vertical adjustment is not necessary.
 21. Adjustable Pipe Roll and Base Units (MSS Type 46): For support of pipes, NPS 2 to NPS 30 (DN 50 to DN 750), if vertical and lateral adjustment during installation might be required in addition to expansion and contraction.
- G. Vertical-Piping Clamps: Unless otherwise indicated and except as specified in piping system Sections, install the following types:
1. Extension Pipe or Riser Clamps (MSS Type 8): For support of pipe risers, NPS 3/4 to NPS 20 (DN 20 to DN 500).
 2. Carbon- or Alloy-Steel Riser Clamps (MSS Type 42): For support of pipe risers, NPS 3/4 to NPS 20 (DN 20 to DN 500), if longer ends are required for riser clamps.
- H. Hanger-Rod Attachments: Unless otherwise indicated and except as specified in piping system Sections, install the following types:
1. Steel Turnbuckles (MSS Type 13): For adjustment up to 6 inches (150 mm) for heavy loads.
 2. Steel Clevises (MSS Type 14): For 120 to 450 deg F (49 to 232 deg C) piping installations.
 3. Swivel Turnbuckles (MSS Type 15): For use with MSS Type 11, split pipe rings.
 4. Malleable-Iron Sockets (MSS Type 16): For attaching hanger rods to various types of building attachments.
 5. Steel Weldless Eye Nuts (MSS Type 17): For 120 to 450 deg F (49 to 232 deg C) piping installations.
- I. Building Attachments: Unless otherwise indicated and except as specified in piping system Sections, install the following types:
1. Steel or Malleable Concrete Inserts (MSS Type 18): For upper attachment to suspend pipe hangers from concrete ceiling.
 2. Top-Beam C-Clamps (MSS Type 19): For use under roof installations with bar-joist construction to attach to top flange of structural shape.
 3. Side-Beam or Channel Clamps (MSS Type 20): For attaching to bottom flange of beams, channels, or angles.
 4. Center-Beam Clamps (MSS Type 21): For attaching to center of bottom flange of beams.
 5. Welded Beam Attachments (MSS Type 22): For attaching to bottom of beams if loads are considerable and rod sizes are large.
 6. C-Clamps (MSS Type 23): For structural shapes.
 7. Top-Beam Clamps (MSS Type 25): For top of beams if hanger rod is required tangent to flange edge.
 8. Side-Beam Clamps (MSS Type 27): For bottom of steel I-beams.

9. Steel-Beam Clamps with Eye Nuts (MSS Type 28): For attaching to bottom of steel I-beams for heavy loads.
 10. Linked-Steel Clamps with Eye Nuts (MSS Type 29): For attaching to bottom of steel I-beams for heavy loads, with link extensions.
 11. Malleable Beam Clamps with Extension Pieces (MSS Type 30): For attaching to structural steel.
 12. Welded-Steel Brackets: For support of pipes from below, or for suspending from above by using clip and rod. Use one of the following for indicated loads:
 - a. Light (MSS Type 31): 750 lb (340 kg).
 - b. Medium (MSS Type 32): 1500 lb (680 kg).
 - c. Heavy (MSS Type 33): 3000 lb (1360 kg).
 13. Side-Beam Brackets (MSS Type 34): For sides of steel or wooden beams.
 14. Plate Lugs (MSS Type 57): For attaching to steel beams if flexibility at beam is required.
 15. Horizontal Travelers (MSS Type 58): For supporting piping systems subject to linear horizontal movement where headroom is limited.
- J. Saddles and Shields: Unless otherwise indicated and except as specified in piping system Sections, install the following types:
1. Steel Pipe-Covering Protection Saddles (MSS Type 39): To fill interior voids with insulation that matches adjoining insulation.
 2. Protection Shields (MSS Type 40): Of length recommended in writing by manufacturer to prevent crushing insulation.
 3. Thermal-Hanger Shield Inserts: For supporting insulated pipe.
- K. Spring Hangers and Supports: Unless otherwise indicated and except as specified in piping system Sections, install the following types:
1. Restraint-Control Devices (MSS Type 47): Where indicated to control piping movement.
 2. Spring Cushions (MSS Type 48): For light loads if vertical movement does not exceed 1-1/4 inches (32 mm).
 3. Spring-Cushion Roll Hangers (MSS Type 49): For equipping Type 41 roll hanger with springs.
 4. Spring Sway Braces (MSS Type 50): To retard sway, shock, vibration, or thermal expansion in piping systems.
 5. Variable-Spring Hangers (MSS Type 51): Preset to indicated load and limit variability factor to 25 percent to absorb expansion and contraction of piping system from hanger.
 6. Variable-Spring Base Supports (MSS Type 52): Preset to indicated load and limit variability factor to 25 percent to absorb expansion and contraction of piping system from base support.
 7. Variable-Spring Trapeze Hangers (MSS Type 53): Preset to indicated load and limit variability factor to 25 percent to absorb expansion and contraction of piping system from trapeze support.
 8. Constant Supports: For critical piping stress and if necessary to avoid transfer of stress from one support to another support, critical terminal, or connected equipment. Include auxiliary stops for erection, hydrostatic test, and load-adjustment capability. These supports include the following types:
 - a. Horizontal (MSS Type 54): Mounted horizontally.
 - b. Vertical (MSS Type 55): Mounted vertically.
 - c. Trapeze (MSS Type 56): Two vertical-type supports and one trapeze member.

- L. Comply with MSS SP-69 for trapeze pipe hanger selections and applications that are not specified in piping system Sections.
- M. Comply with MFMA-102 for metal framing system selections and applications that are not specified in piping system Sections.
- N. Use powder-actuated fasteners or mechanical-expansion anchors instead of building attachments where required in concrete construction.
- O. Use pipe positioning systems in pipe spaces behind plumbing fixtures to support supply and waste piping for plumbing fixtures.

3.2 HANGER AND SUPPORT INSTALLATION

- A. Steel Pipe Hanger Installation: Comply with MSS SP-69 and MSS SP-89. Install hangers, supports, clamps, and attachments as required to properly support piping from building structure.
- B. Trapeze Pipe Hanger Installation: Comply with MSS SP-69 and MSS SP-89. Arrange for grouping of parallel runs of horizontal piping and support together on field-fabricated trapeze pipe hangers.
 - 1. Pipes of Various Sizes: Support together and space trapezes for smallest pipe size or install intermediate supports for smaller diameter pipes as specified above for individual pipe hangers.
 - 2. Field fabricate from ASTM A 36/A 36M, steel shapes selected for loads being supported. Weld steel according to AWS D1.1.
- C. Metal Framing System Installation: Arrange for grouping of parallel runs of piping and support together on field-assembled metal framing systems.
- D. Thermal-Hanger Shield Installation: Install in pipe hanger or shield for insulated piping.
- E. Fastener System Installation:
 - 1. Install powder-actuated fasteners for use in lightweight concrete or concrete slabs less than 4 inches (100 mm) thick in concrete after concrete is placed and completely cured. Use operators that are licensed by powder-actuated tool manufacturer. Install fasteners according to powder-actuated tool manufacturer's operating manual.
 - 2. Install mechanical-expansion anchors in concrete after concrete is placed and completely cured. Install fasteners according to manufacturer's written instructions.
- F. Pipe Stand Installation:
 - 1. Pipe Stand Types except Curb-Mounting Type: Assemble components and mount on smooth roof surface. Do not penetrate roof membrane.
 - 2. Curb-Mounting-Type Pipe Stands: Assemble components or fabricate pipe stand and mount on permanent, stationary roof curb. Refer to Division 07 Section "Roof Accessories" for curbs.
- G. Pipe Positioning System Installation: Install support devices to make rigid supply and waste piping connections to each plumbing fixture. Refer to Division 22 Section "Plumbing Fixtures" for plumbing fixtures.
- H. Install hangers and supports complete with necessary inserts, bolts, rods, nuts, washers, and other accessories.
- I. Equipment Support Installation: Fabricate from welded-structural-steel shapes.

- J. Install hangers and supports to allow controlled thermal and seismic movement of piping systems, to permit freedom of movement between pipe anchors, and to facilitate action of expansion joints, expansion loops, expansion bends, and similar units.
- K. Install lateral bracing with pipe hangers and supports to prevent swaying.
- L. Install building attachments within concrete slabs or attach to structural steel. Install additional attachments at concentrated loads, including valves, flanges, and strainers, NPS 2-1/2 (DN 65) and larger and at changes in direction of piping. Install concrete inserts before concrete is placed; fasten inserts to forms and install reinforcing bars through openings at top of inserts.
- M. Load Distribution: Install hangers and supports so piping live and dead loads and stresses from movement will not be transmitted to connected equipment.
- N. Pipe Slopes: Install hangers and supports to provide indicated pipe slopes and so maximum pipe deflections allowed by ASME B31.9 (for building services piping) are not exceeded.
- O. Insulated Piping: Comply with the following:
 - 1. Attach clamps and spacers to piping.
 - a. Piping Operating above Ambient Air Temperature: Clamp may project through insulation.
 - b. Piping Operating below Ambient Air Temperature: Use thermal-hanger shield insert with clamp sized to match OD of insert.
 - c. Do not exceed pipe stress limits according to ASME B31.9 for building services piping.
 - 2. Install MSS SP-58, Type 39, protection saddles if insulation without vapor barrier is indicated. Fill interior voids with insulation that matches adjoining insulation.
 - a. Option: Thermal-hanger shield inserts may be used. Include steel weight-distribution plate for pipe NPS 4 (DN 100) and larger if pipe is installed on rollers.
 - 3. Install MSS SP-58, Type 40, protective shields on cold piping with vapor barrier. Shields shall span an arc of 180 degrees.
 - a. Option: Thermal-hanger shield inserts may be used. Include steel weight-distribution plate for pipe NPS 4 (DN 100) and larger if pipe is installed on rollers.
 - 4. Shield Dimensions for Pipe: Not less than the following:
 - a. NPS 1/4 to NPS 3-1/2 (DN 8 to DN 90): 12 inches (305 mm) long and 0.048 inch (1.22 mm) thick.
 - b. NPS 4 (DN 100): 12 inches (305 mm) long and 0.06 inch (1.52 mm) thick.
 - c. NPS 5 and NPS 6 (DN 125 and DN 150): 18 inches (457 mm) long and 0.06 inch (1.52 mm) thick.
 - d. NPS 8 to NPS 14 (DN 200 to DN 350): 24 inches (610 mm) long and 0.075 inch (1.91 mm) thick.
 - e. NPS 16 to NPS 24 (DN 400 to DN 600): 24 inches (610 mm) long and 0.105 inch (2.67 mm) thick.
 - 5. Pipes NPS 8 (DN 200) and Larger: Include wood inserts.
 - 6. Insert Material: Length at least as long as protective shield.
 - 7. Thermal-Hanger Shields: Install with insulation same thickness as piping insulation.

3.3 EQUIPMENT SUPPORTS

- A. Fabricate structural-steel stands to suspend equipment from structure overhead or to support equipment above floor.
- B. Grouting: Place grout under supports for equipment and make smooth bearing surface.
- C. Provide lateral bracing, to prevent swaying, for equipment supports.

3.4 METAL FABRICATIONS

- A. Cut, drill, and fit miscellaneous metal fabrications for trapeze pipe hangers and equipment supports.
- B. Fit exposed connections together to form hairline joints. Field weld connections that cannot be shop welded because of shipping size limitations.
- C. Field Welding: Comply with AWS D1.1 procedures for shielded metal arc welding, appearance and quality of welds, and methods used in correcting welding work, and with the following:
 - 1. Use materials and methods that minimize distortion and develop strength and corrosion resistance of base metals.
 - 2. Obtain fusion without undercut or overlap.
 - 3. Remove welding flux immediately.
 - 4. Finish welds at exposed connections so no roughness shows after finishing and contours of welded surfaces match adjacent contours.

3.5 ADJUSTING

- A. Hanger Adjustments: Adjust hangers to distribute loads equally on attachments and to achieve indicated slope of pipe.
- B. Trim excess length of continuous-thread hanger and support rods to 1-1/2 inches (40 mm).

3.6 PAINTING

- A. Touch Up: Clean field welds and abraded areas of shop paint. Paint exposed areas immediately after erecting hangers and supports. Use same materials as used for shop painting. Comply with SSPC-PA 1 requirements for touching up field-painted surfaces.
 - 1. Apply paint by brush or spray to provide minimum dry film thickness of 2.0 mils (0.05 mm).
- B. Touch Up: Cleaning and touchup painting of field welds, bolted connections, and abraded areas of shop paint on miscellaneous metal are specified in Division 09 painting Sections.
- C. Galvanized Surfaces: Clean welds, bolted connections, and abraded areas and apply galvanizing-repair paint to comply with ASTM A 780.

END OF SECTION

This page is intentionally left blank.

Section 22 05 53

IDENTIFICATION FOR PLUMBING PIPING AND EQUIPMENT

PART 1 - GENERAL

1.1 RELATED DOCUMENTS

- A. Drawings and general provisions of the Contract, including General and Supplementary Conditions and Division 01 Specification Sections, apply to this Section.
- B. Section 01 81 13 "Sustainable Design Requirements – LEED v4 for Building Design & Construction – New Construction" for sustainable design requirements and detailed sustainable design submittal requirements.
- C. Section 01 74 19 "Construction and Demolition Waste Management and Disposal" for disposal of construction, demolition and packaging waste disposal requirements.

1.2 SUMMARY

- A. Section Includes:
 - 1. Equipment labels.
 - 2. Warning signs and labels.
 - 3. Pipe labels.
 - 4. Stencils.
 - 5. Valve tags.
 - 6. Warning tags.
- B. Sustainable Building Requirements:
 - 1. The Owner requires the Contractor to implement practices and procedures to meet the project's environmental performance goals, which include achieving LEED version 4 **Certified** level Certification. Specific project goals that may impact this area of work include: use of recycled-content materials; use of locally-manufactured materials; use of low-emitting materials; construction waste recycling; and the implementation of a construction indoor air quality management plan. The Contractor shall ensure that the requirements related to these goals, as defined in the Articles below, are implemented to the fullest extent. Substitutions, or other changes to the work proposed by the Contractor or their Subcontractors, shall not be allowed if such changes compromise the aforementioned environmental goals and LEED certification.

1.3 SUBMITTALS

- A. Product Data: For each type of product indicated.
- B. Samples: For color, letter style, and graphic representation required for each identification material and device.
- C. Equipment Label Schedule: Include a listing of all equipment to be labeled with the proposed content for each label.

- D. Valve numbering scheme.
- E. Valve Schedules: For each piping system to include in maintenance manuals.

1.4 COORDINATION

- A. Coordinate installation of identifying devices with completion of covering and painting of surfaces where devices are to be applied.
- B. Coordinate installation of identifying devices with locations of access panels and doors.
- C. Install identifying devices before installing acoustical ceilings and similar concealment.

PART 2 - PRODUCTS

2.1 EQUIPMENT LABELS

- A. Plastic Labels for Equipment:
 - 1. Material and Thickness: Multilayer, multicolor, plastic labels for mechanical engraving, 1/8 inch (3.2 mm) thick, and having predrilled holes for attachment hardware.
 - 2. Letter Color: White.
 - 3. Background Color: Black.
 - 4. Maximum Temperature: Able to withstand temperatures up to 160 deg F (71 deg C).
 - 5. Minimum Label Size: Length and width vary for required label content, but not less than 2-1/2 by 3/4 inch (64 by 19 mm).
 - 6. Minimum Letter Size: 1/4 inch (6.4 mm) for name of units if viewing distance is less than 24 inches (600 mm), 1/2 inch (13 mm) for viewing distances up to 72 inches (1830 mm), and proportionately larger lettering for greater viewing distances. Include secondary lettering two-thirds to three-fourths the size of principal lettering.
 - 7. Fasteners: Stainless-steel rivets or self-tapping screws.
 - 8. Adhesive: Contact-type permanent adhesive, compatible with label and with substrate.
- B. Label Content: Include equipment's Drawing designation or unique equipment number, Drawing numbers where equipment is indicated (plans, details, and schedules), plus the Specification Section number and title where equipment is specified.
- C. Equipment Label Schedule: For each item of equipment to be labeled, on 8-1/2-by-11-inch (A4) bond paper. Tabulate equipment identification number and identify Drawing numbers where equipment is indicated (plans, details, and schedules), plus the Specification Section number and title where equipment is specified. Equipment schedule shall be included in operation and maintenance data.

2.2 WARNING SIGNS AND LABELS

- A. Material and Thickness: Multilayer, multicolor, plastic labels for mechanical engraving, 1/8 inch (3.2 mm) thick, and having predrilled holes for attachment hardware.

- B. Letter Color: White.
- C. Background Color: Red.
- D. Maximum Temperature: Able to withstand temperatures up to 160 deg F (71 deg C).
- E. Minimum Label Size: Length and width vary for required label content, but not less than 2-1/2 by 3/4 inch (64 by 19 mm).
- F. Minimum Letter Size: 1/4 inch (6.4 mm) for name of units if viewing distance is less than 24 inches (600 mm), 1/2 inch (13 mm) for viewing distances up to 72 inches (1830 mm), and proportionately larger lettering for greater viewing distances. Include secondary lettering two-thirds to three-fourths the size of principal lettering.
- G. Fasteners: Stainless-steel rivets or self-tapping screws.
- H. Adhesive: Contact-type permanent adhesive, compatible with label and with substrate.
- I. Label Content: Include caution and warning information, plus emergency notification instructions.

2.3 PIPE LABELS

- A. General Requirements for Manufactured Pipe Labels: Preprinted, color-coded, with lettering indicating service, and showing flow direction.
- B. Pretensioned Pipe Labels: Precoiled, semirigid plastic formed to cover full circumference of pipe and to attach to pipe without fasteners or adhesive.
- C. Self-Adhesive Pipe Labels: Printed plastic with contact-type, permanent-adhesive backing.
- D. Pipe Label Contents: Include identification of piping service using same designations or abbreviations as used on Drawings, pipe size, and an arrow indicating flow direction.
 - 1. Flow-Direction Arrows: Integral with piping system service lettering to accommodate both directions, or as separate unit on each pipe label to indicate flow direction.
 - 2. Lettering Size: At least 1-1/2 inches (38 mm) high.

2.4 STENCILS

- A. Stencils: Prepared with letter sizes according to ASME A13.1 for piping; and minimum letter height of 3/4 inch (19 mm) for access panel and door labels, equipment labels, and similar operational instructions.
 - 1. Stencil Material: Fiberboard or metal.
 - 2. Stencil Paint: Exterior, gloss, alkyd enamel black unless otherwise indicated. Paint may be in pressurized spray-can form.
 - 3. Identification Paint: Exterior, alkyd enamel in colors according to ASME A13.1 unless otherwise indicated.

2.5 VALVE TAGS

- A. Valve Tags: Stamped or engraved with 1/4-inch (6.4-mm) letters for piping system abbreviation and 1/2-inch (13-mm) numbers.
 - 1. Tag Material: Brass, 0.032-inch (0.8-mm) minimum thickness, and having predrilled or stamped holes for attachment hardware.
 - 2. Fasteners: Brass wire-link or beaded chain; or S-hook .
- B. Valve Schedules: For each piping system, on 8-1/2-by-11-inch (A4) bond paper. Tabulate valve number, piping system, system abbreviation (as shown on valve tag), location of valve (room or space), normal-operating position (open, closed, or modulating), and variations for identification. Mark valves for emergency shutoff and similar special uses.
 - 1. Valve-tag schedule shall be included in operation and maintenance data.
 - 2. Valve-tag schedule(s) shall be mounted in locations to be directed by Owner. Mountings shall be in a metal frame with plexi-glass (clear) cover.

PART 3 - EXECUTION

3.1 PREPARATION

- A. Clean piping and equipment surfaces of substances that could impair bond of identification devices, including dirt, oil, grease, release agents, and incompatible primers, paints, and encapsulants.

3.2 EQUIPMENT LABEL INSTALLATION

- A. Install or permanently fasten labels on each major item of mechanical equipment.
- B. Locate equipment labels where accessible and visible.

3.3 PIPE LABEL INSTALLATION

- A. Piping Color-Coding: Painting of piping is specified in Division 09 Section "Interior Painting."
- B. Stenciled Pipe Label Option: Stenciled labels may be provided instead of manufactured pipe labels, at Installer's option. Install stenciled pipe labels with painted, color-coded bands or rectangles, complying with ASME A13.1, on each piping system.
 - 1. Identification Paint: Use for contrasting background.
 - 2. Stencil Paint: Use for pipe marking.
- C. Locate pipe labels where piping is exposed or above accessible ceilings in finished spaces; machine rooms; accessible maintenance spaces such as shafts, tunnels, and plenums; and exterior exposed locations as follows:
 - 1. Near each valve and control device.
 - 2. Near each branch connection, excluding short takeoffs for fixtures and terminal units. Where flow pattern is not obvious, mark each pipe at branch.
 - 3. Near penetrations through walls, floors, ceilings, and inaccessible enclosures.
 - 4. At access doors, manholes, and similar access points that permit view of concealed piping.
 - 5. Near major equipment items and other points of origination and termination.

6. Spaced at maximum intervals of 50 feet (15 m) along each run. Reduce intervals to 25 feet (7.6 m) in areas of congested piping and equipment.
7. On piping above removable acoustical ceilings. Omit intermediately spaced labels.

D. Pipe Label Color Schedule:

1. Low-Pressure, Compressed-Air Piping:
 - a. Background Color: Green
 - b. Letter Color: White
2. Domestic Water Piping:
 - a. Background Color: Green
 - b. Letter Color: White
3. Sanitary Waste Piping:
 - a. Background Color: Green
 - b. Letter Color: White
4. Non-Domestic Water Piping:
 - a. Background Color: Green
 - b. Letter Color: White
5. Natural Gas Piping:
 - a. Background Color: Green
 - b. Letter Color: White
6. Medical Gas and Vacuum:
 - a. Background Color: Green
 - b. Letter Color: White

3.4 VALVE-TAG INSTALLATION

- A. Install tags on valves and control devices in piping systems, except check valves; valves within factory-fabricated equipment units; shutoff valves; faucets; convenience and lawn-watering hose connections; and similar roughing-in connections of end-use fixtures and units. List tagged valves in a valve schedule.
- B. Valve-Tag Application Schedule: Tag valves according to size, shape, and color scheme and with captions similar to those indicated in the following subparagraphs:
 1. Valve-Tag Size and Shape:
 - a. Domestic and Non-Domestic Cold Water: 2 inches (50 mm), round.
 - b. Domestic and Non-Domestic Hot Water: 2 inches (50 mm), round.
 - c. Low-Pressure Compressed Air: 2 inches (50 mm), square.
 - d. Natural Gas: 2 inches (50mm), square.
 2. Valve-Tag Color:
 - a. Domestic and Non-Domestic Cold Water: Natural.
 - b. Domestic and Non-Domestic Hot Water: Natural.
 - c. Low-Pressure Compressed Air: Natural.
 - d. Natural Gas: Natural.
 3. Letter Color:
 - a. Domestic and Non-Domestic Cold Water: Black.
 - b. Domestic and Non-Domestic Hot Water: Black.
 - c. Low-Pressure Compressed Air: Black.
 - d. Natural Gas: Black.

END OF SECTION

This page is intentionally left blank.

SECTION 22 07 00

PLUMBING INSULATION

PART 1 - GENERAL

1.1 RELATED DOCUMENTS

- A. Drawings and general provisions of the Contract, including General and Supplementary Conditions and Division 01 Specification Sections, apply to this Section.
- B. Section 01 81 13 "Sustainable Design Requirements – LEED v4 for Building Design & Construction – New Construction" for sustainable design requirements and detailed sustainable design submittal requirements.
- C. Section 01 74 19 "Construction and Demolition Waste Management and Disposal" for disposal of construction, demolition and packaging waste disposal requirements.

1.2 SUMMARY

- A. Section Includes:
 - 1. Insulation Materials:
 - a. Flexible elastomeric.
 - b. Mineral fiber.
 - 2. Insulating cements.
 - 3. Adhesives.
 - 4. Sealants.
 - 5. Factory-applied jackets.
 - 6. Field-applied jackets.
 - 7. Tapes.
 - 8. Securements.
 - 9. Corner angles.
- B. Sustainable Building Requirements:
 - 1. The Owner requires the Contractor to implement practices and procedures to meet the project's environmental performance goals, which include achieving LEED version 4 **Certified** level Certification. Specific project goals that may impact this area of work include: use of recycled-content materials; use of locally-manufactured materials; use of low-emitting materials; construction waste recycling; and the implementation of a construction indoor air quality management plan. The Contractor shall ensure that the requirements related to these goals, as defined in the Articles below, are implemented to the fullest extent. Substitutions, or other changes to the work proposed by the Contractor or their Subcontractors, shall not be allowed if such changes compromise the aforementioned environmental goals and LEED certification.

1.3 SUBMITTALS

- A. Product Data: For each type of product indicated. Include thermal conductivity, thickness, and jackets (both factory and field applied, if any).
- B. Shop Drawings:
 - 1. Detail application of protective shields, saddles, and inserts at hangers for each type of insulation and hanger.
 - 2. Detail attachment and covering of heat tracing inside insulation.
 - 3. Detail insulation application at pipe expansion joints for each type of insulation.
 - 4. Detail insulation application at elbows, fittings, flanges, valves, and specialties for each type of insulation.
 - 5. Detail removable insulation at piping specialties, equipment connections, and access panels.
 - 6. Detail application of field-applied jackets.
 - 7. Detail field application for each equipment type.
- C. Samples: For each type of insulation and jacket indicated. Identify each Sample, describing product and intended use. Sample sizes are as follows:
 - 1. Sample Sizes:
 - a. Preformed Pipe Insulation Materials: 12 inches (300 mm) long by NPS 2 (DN 50).
 - b. Manufacturer's Color Charts: For products where color is specified, show the full range of colors available for each type of finish material.
- D. Qualification Data: For qualified Installer.
- E. Material Test Reports: From a qualified testing agency acceptable to authorities having jurisdiction indicating, interpreting, and certifying test results for compliance of insulation materials, sealers, attachments, cements, and jackets, with requirements indicated. Include dates of tests and test methods employed.
- F. Field quality-control reports.

1.4 QUALITY ASSURANCE

- A. Installer Qualifications: Skilled mechanics who have successfully completed an apprenticeship program or another craft training program certified by the Department of Labor, Bureau of Apprenticeship and Training.
- B. Fire-Test-Response Characteristics: Insulation and related materials shall have fire-test-response characteristics indicated, as determined by testing identical products per ASTM E 84, by a testing and inspecting agency acceptable to authorities having jurisdiction. Factory label insulation and jacket materials and adhesive, mastic, tapes, and cement material containers, with appropriate markings of applicable testing and inspecting agency.
 - 1. Insulation Installed Indoors: Flame-spread index of 25 or less, and smoke-developed index of 50 or less.
 - 2. Insulation Installed Outdoors: Flame-spread index of 75 or less, and smoke-developed index of 150 or less.

1.5 DELIVERY, STORAGE, AND HANDLING

- A. Packaging: Insulation material containers shall be marked by manufacturer with appropriate ASTM standard designation, type and grade, and maximum use temperature.

1.6 COORDINATION

- A. Coordinate size and location of supports, hangers, and insulation shields specified in Division 22 Section "Hangers and Supports for Plumbing Piping and Equipment."
- B. Coordinate clearance requirements with piping Installer for piping insulation application and equipment Installer for equipment insulation application. Before preparing piping Shop Drawings, establish and maintain clearance requirements for installation of insulation and field-applied jackets and finishes and for space required for maintenance.
- C. Coordinate installation and testing of heat tracing.

1.7 SCHEDULING

- A. Schedule insulation application after pressure testing systems and, where required, after installing and testing heat tracing. Insulation application may begin on segments that have satisfactory test results.
- B. Complete installation and concealment of plastic materials as rapidly as possible in each area of construction.

PART 2 - PRODUCTS

2.1 INSULATION MATERIALS

- A. Comply with requirements in Part 3 schedule articles for where insulating materials shall be applied.
- B. Products shall not contain asbestos, lead, mercury, or mercury compounds.
- C. Products that come in contact with stainless steel shall have a leachable chloride content of less than 50 ppm when tested according to ASTM C 871.
- D. Insulation materials for use on austenitic stainless steel shall be qualified as acceptable according to ASTM C 795.
- E. Foam insulation materials shall not use CFC or HCFC blowing agents in the manufacturing process.
- F. Flexible Elastomeric: Closed-cell, sponge- or expanded-rubber materials. Comply with ASTM C 534, Type I for tubular materials and Type II for sheet materials.
 - 1. Products: Subject to compliance with requirements, provide one of the following:
 - a. Aeroflex USA Inc.; Aerocel.
 - b. Armacell LLC; AP Armaflex.
 - c. RBX Corporation; Insul-Sheet 1800 and Insul-Tube 180.
- G. Mineral-Fiber, Preformed Pipe Insulation:

1. Products: Subject to compliance with requirements, provide one of the following:
 - a. Johns Manville; Micro-Lok.
 - b. Knauf Insulation; 1000(Pipe Insulation.
 - c. Owens Corning; Fiberglas Pipe Insulation.
 2. Type I, 850 deg F (454 deg C) Materials: Mineral or glass fibers bonded with a thermosetting resin. Comply with ASTM C 547, Type I, Grade A, with factory-applied ASJ-SSL. Factory-applied jacket requirements are specified in "Factory-Applied Jackets" Article.
- H. Mineral-Fiber, Pipe and Tank Insulation: Mineral or glass fibers bonded with a thermosetting resin. Semirigid board material with factory-applied ASJcomplying with ASTM C 1393, Type II or Type IIIA Category 2, or with properties similar to ASTM C 612, Type IB. Nominal density is 2.5 lb/cu. ft. (40 kg/cu. m) or more. Thermal conductivity (k-value) at 100 deg F (55 deg C) is 0.29 Btu x in./h x sq. ft. x deg F (0.042 W/m x K) or less. Factory-applied jacket requirements are specified in "Factory-Applied Jackets" Article.
1. Products: Subject to compliance with requirements, provide one of the following:
 - a. CertainTeed Corp.; CrimpWrap.
 - b. Johns Manville; MicroFlex.
 - c. Knauf Insulation; Pipe and Tank Insulation.
 - d. Owens Corning; Fiberglas Pipe and Tank Insulation.

2.2 ADHESIVES

- A. Materials shall be compatible with insulation materials, jackets, and substrates and for bonding insulation to itself and to surfaces to be insulated, unless otherwise indicated.
- B. Flexible Elastomeric and Polyolefin Adhesive: Comply with MIL-A-24179A, Type II, Class I.
1. Products: Subject to compliance with requirements, provide one of the following:
 - a. Aeroflex USA Inc.; Aeroseal.
 - b. Armacell LCC; 520 Adhesive.
 - c. RBX Corporation; Rubatex Contact Adhesive.
- C. Mineral-Fiber Adhesive: Comply with MIL-A-3316C, Class 2, Grade A.
1. Products: Subject to compliance with requirements, provide one of the following:
 - a. Childers Products, Division of ITW; CP-82.
 - b. Foster Products Corporation, H. B. Fuller Company; 85-20.
 - c. ITW TACC, Division of Illinois Tool Works; S-90/80.
 - d. Marathon Industries, Inc.; 225.
 - e. Mon-Eco Industries, Inc.; 22-25.
- D. ASJ Adhesive, and FSK and PVDC Jacket Adhesive: Comply with MIL-A-3316C, Class 2, Grade A for bonding insulation jacket lap seams and joints.
1. Products: Subject to compliance with requirements, provide one of the following:
 - a. Childers Products, Division of ITW; CP-82.
 - b. Foster Products Corporation, H. B. Fuller Company; 85-20.
 - c. ITW TACC, Division of Illinois Tool Works; S-90/80.

- d. Marathon Industries, Inc.; 225.
 - e. Mon-Eco Industries, Inc.; 22-25.
- E. PVC Jacket Adhesive: Compatible with PVC jacket.
- 1. Products: Subject to compliance with requirements, provide one of the following:
 - a. Dow Chemical Company (The); 739, Dow Silicone.
 - b. Johns-Manville; Zeston Perma-Weld, CEEL-TITE Solvent Welding Adhesive.
 - c. P.I.C. Plastics, Inc.; Welding Adhesive.
 - d. Red Devil, Inc.; Celulon Ultra Clear.
 - e. Speedline Corporation; Speedline Vinyl Adhesive.

2.3 SEALANTS

- A. FSK and Metal Jacket Flashing Sealants:
- 1. Products: Subject to compliance with requirements, provide one of the following:
 - a. Childers Products, Division of ITW; CP-76-8.
 - b. Foster Products Corporation, H. B. Fuller Company; 95-44.
 - c. Marathon Industries, Inc.; 405.
 - d. Mon-Eco Industries, Inc.; 44-05.
 - e. Vimasco Corporation; 750.
 - 2. Materials shall be compatible with insulation materials, jackets, and substrates.
 - 3. Fire- and water-resistant, flexible, elastomeric sealant.
 - 4. Service Temperature Range: Minus 40 to plus 250 deg F (Minus 40 to plus 121 deg C).
 - 5. Color: Aluminum.
- B. ASJ Flashing Sealants, and Vinyl, PVDC, and PVC Jacket Flashing Sealants:
- 1. Products: Subject to compliance with requirements, provide one of the following:
 - a. Childers Products, Division of ITW; CP-76.
 - b. Insert manufacturer's name; product name or designation.
 - 2. Materials shall be compatible with insulation materials, jackets, and substrates.
 - 3. Fire- and water-resistant, flexible, elastomeric sealant.
 - 4. Service Temperature Range: Minus 40 to plus 250 deg F (Minus 40 to plus 121 deg C).
 - 5. Color: White.

2.4 FACTORY-APPLIED JACKETS

- A. Insulation system schedules indicate factory-applied jackets on various applications. When factory-applied jackets are indicated, comply with the following:
- 1. ASJ: White, kraft-paper, fiberglass-reinforced scrim with aluminum-foil backing; complying with ASTM C 1136, Type I.
 - 2. ASJ-SSL: ASJ with self-sealing, pressure-sensitive, acrylic-based adhesive covered by a removable protective strip; complying with ASTM C 1136, Type I.

3. FSK Jacket: Aluminum-foil, fiberglass-reinforced scrim with kraft-paper backing; complying with ASTM C 1136, Type II.
4. PVDC Jacket for Indoor Applications: 4-mil- (0.10-mm-) thick, white PVDC biaxially oriented barrier film with a permeance at 0.02 perms (0.013 metric perms) when tested according to ASTM E 96 and with a flame-spread index of 5 and a smoke-developed index of 20 when tested according to ASTM E 84.

2.5 FIELD-APPLIED JACKETS

- A. Field-applied jackets shall comply with ASTM C 921, Type I, unless otherwise indicated.
- B. PVC Jacket: High-impact-resistant, UV-resistant PVC complying with ASTM D 1784, Class 16354-C; thickness as scheduled; roll stock ready for shop or field cutting and forming. Thickness is indicated in field-applied jacket schedules.
 1. Products: Subject to compliance with requirements, provide one of the following:
 - a. Johns Manville; Zeston.
 - b. P.I.C. Plastics, Inc.; FG Series.
 - c. Proto PVC Corporation; LoSmoke.
 - d. Speedline Corporation; SmokeSafe.
 2. Adhesive: As recommended by jacket material manufacturer.
 3. Color: White.
 4. Factory-fabricated fitting covers to match jacket if available; otherwise, field fabricate.
 - a. Shapes: 45- and 90-degree, short- and long-radius elbows, tees, valves, flanges, unions, reducers, end caps, soil-pipe hubs, traps, mechanical joints, and P-trap and supply covers for lavatories.
 5. Factory-fabricated tank heads and tank side panels.
- C. Metal Jacket:
 1. Products: Subject to compliance with requirements, provide one of the following:
 - a. Childers Products, Division of ITW; Metal Jacketing Systems.
 - b. PABCO Metals Corporation; Surefit.
 - c. RPR Products, Inc.; Insul-Mate.
 2. Aluminum Jacket: Comply with ASTM B 209 (ASTM B 209M), Alloy 3003, 3005, 3105 or 5005, Temper H-14.
 - a. Factory cut and rolled to size.
 - b. Finish and thickness are indicated in field-applied jacket schedules.
 - c. Moisture Barrier for Indoor Applications: 1-mil- (0.025-mm-) thick, heat-bonded polyethylene and kraft paper .
 - d. Moisture Barrier for Outdoor Applications: 3-mil- (0.075-mm-) thick, heat-bonded polyethylene and kraft paper.
 - e. Factory-Fabricated Fitting Covers:
 - 1) Same material, finish, and thickness as jacket.
 - 2) Preformed 2-piece or gore, 45- and 90-degree, short- and long-radius elbows.
 - 3) Tee covers.
 - 4) Flange and union covers.
 - 5) End caps.
 - 6) Beveled collars.
 - 7) Valve covers.

- 8) Field fabricate fitting covers only if factory-fabricated fitting covers are not available.
3. Stainless-Steel Jacket: ASTM A 167 or ASTM A 240/A 240M.
 - a. Factory cut and rolled to size.
 - b. Material, finish, and thickness are indicated in field-applied jacket schedules.
 - c. Moisture Barrier for Indoor Applications: 1-mil- (0.025-mm-) thick, heat-bonded polyethylene and kraft paper .
 - d. Moisture Barrier for Outdoor Applications: 3-mil- (0.075-mm-) thick, heat-bonded polyethylene and kraft paper.
 - e. Factory-Fabricated Fitting Covers:
 - 1) Same material, finish, and thickness as jacket.
 - 2) Preformed 2-piece or gore, 45- and 90-degree, short- and long-radius elbows.
 - 3) Tee covers.
 - 4) Flange and union covers.
 - 5) End caps.
 - 6) Beveled collars.
 - 7) Valve covers.
 - 8) Field fabricate fitting covers only if factory-fabricated fitting covers are not available.

2.6 TAPES

- A. ASJ Tape: White vapor-retarder tape matching factory-applied jacket with acrylic adhesive, complying with ASTM C 1136.
 1. Products: Subject to compliance with requirements, provide one of the following:
 - a. Avery Dennison Corporation, Specialty Tapes Division; Fasson 0835.
 - b. Compac Corp.; 104 and 105.
 - c. Ideal Tape Co., Inc., an American Biltrite Company; 428 AWF ASJ.
 - d. Venture Tape; 1540 CW Plus, 1542 CW Plus, and 1542 CW Plus/SQ.
 2. Width: 3 inches (75 mm).
 3. Thickness: 11.5 mils (0.29 mm).
 4. Adhesion: 90 ounces force/inch (1.0 N/mm) in width.
 5. Elongation: 2 percent.
 6. Tensile Strength: 40 lbf/inch (7.2 N/mm) in width.
 7. ASJ Tape Disks and Squares: Precut disks or squares of ASJ tape.
- B. FSK Tape: Foil-face, vapor-retarder tape matching factory-applied jacket with acrylic adhesive; complying with ASTM C 1136.
 1. Products: Subject to compliance with requirements, provide one of the following:
 - a. Avery Dennison Corporation, Specialty Tapes Division; Fasson 0827.
 - b. Compac Corp.; 110 and 111.
 - c. Ideal Tape Co., Inc., an American Biltrite Company; 491 AWF FSK.
 - d. Venture Tape; 1525 CW, 1528 CW, and 1528 CW/SQ.
 2. Width: 3 inches (75 mm).
 3. Thickness: 6.5 mils (0.16 mm).
 4. Adhesion: 90 ounces force/inch (1.0 N/mm) in width.
 5. Elongation: 2 percent.
 6. Tensile Strength: 40 lbf/inch (7.2 N/mm) in width.
 7. FSK Tape Disks and Squares: Precut disks or squares of FSK tape.

- C. PVC Tape: White vapor-retarder tape matching field-applied PVC jacket with acrylic adhesive. Suitable for indoor and outdoor applications.
1. Products: Subject to compliance with requirements, provide one of the following:
 - a. Avery Dennison Corporation, Specialty Tapes Division; Fasson 0555.
 - b. Compac Corp.; 130.
 - c. Ideal Tape Co., Inc., an American Biltrite Company; 370 White PVC tape.
 - d. Venture Tape; 1506 CW NS.
 2. Width: 2 inches (50 mm).
 3. Thickness: 6 mils (0.15 mm).
 4. Adhesion: 64 ounces force/inch (0.7 N/mm) in width.
 5. Elongation: 500 percent.
 6. Tensile Strength: 18 lbf/inch (3.3 N/mm) in width.

2.7 SECUREMENTS

A. Bands:

1. Products: Subject to compliance with requirements, provide one of the following:
 - a. Childers Products; Bands.
 - b. PABCO Metals Corporation; Bands.
 - c. RPR Products, Inc.; Bands.
2. Stainless Steel: ASTM A 167 or ASTM A 240/A 240M, Type 304; 0.015 inch (0.38 mm) thick, 1/2 inch (13 mm) wide with wing or closed seal.

B. Insulation Pins and Hangers:

1. Metal, Adhesively Attached, Perforated-Base Insulation Hangers: Baseplate welded to projecting spindle that is capable of holding insulation, of thickness indicated, securely in position indicated when self-locking washer is in place. Comply with the following requirements:
 - a. Products: Subject to compliance with requirements, provide one of the following:
 - 1) AGM Industries, Inc.; Tactoo Insul-Hangers, Series T.
 - 2) GEMCO; Perforated Base.
 - 3) Midwest Fasteners, Inc.; Spindle.
 - b. Baseplate: Perforated, galvanized carbon-steel sheet, 0.030 inch (0.76 mm) thick by 2 inches (50 mm) square.
 - c. Spindle: Aluminum, fully annealed, 0.106-inch- (2.6-mm-) diameter shank, length to suit depth of insulation indicated.
 - d. Adhesive: Recommended by hanger manufacturer. Product with demonstrated capability to bond insulation hanger securely to substrates indicated without damaging insulation, hangers, and substrates.
2. Insulation-Retaining Washers: Self-locking washers formed from 0.016-inch- (0.41-mm-) thick, aluminum sheet, with beveled edge sized as required to hold insulation securely in place but not less than 1-1/2 inches (38 mm) in diameter.
 - a. Products: Subject to compliance with requirements, provide one of the following:
 - 1) AGM Industries, Inc.; RC-150.
 - 2) GEMCO; R-150.
 - 3) Midwest Fasteners, Inc.; WA-150.

- 4) Nelson Stud Welding; Speed Clips.
 - b. Protect ends with capped self-locking washers incorporating a spring steel insert to ensure permanent retention of cap in exposed locations.
 - C. Staples: Outward-clinching insulation staples, nominal 3/4-inch- (19-mm-) wide, stainless steel or Monel.
 - D. Wire: 0.062-inch (1.6-mm) soft-annealed, stainless steel.
 - 1. Manufacturers: Subject to compliance with requirements, provide products by one of the following:
 - a. C & F Wire.
 - b. Childers Products.
 - c. PABCO Metals Corporation.
 - d. RPR Products, Inc.
- 2.8 FIRE WRAP
- A. Provide 3 μ fire wrap for all piping required to meet fire resistances rating.
- 2.9 PLENUM WRAP
- A. Provide 3 μ Plenum wrap for all piping required to meet fire smoke density requirements.

PART 3 - EXECUTION

- 3.1 EXAMINATION
- A. Examine substrates and conditions for compliance with requirements for installation and other conditions affecting performance of insulation application.
 - 1. Verify that systems and equipment to be insulated have been tested and are free of defects.
 - 2. Verify that surfaces to be insulated are clean and dry.
 - 3. Proceed with installation only after unsatisfactory conditions have been corrected.
- 3.2 PREPARATION
- A. Surface Preparation: Clean and dry surfaces to receive insulation. Remove materials that will adversely affect insulation application.
 - B. Surface Preparation: Clean and prepare surfaces to be insulated. Before insulating, apply a corrosion coating to insulated surfaces as follows:
 - 1. Stainless Steel: Coat 300 series stainless steel with an epoxy primer 5 mils (0.127 mm) thick and an epoxy finish 5 mils (0.127 mm) thick if operating in a temperature range between 140 and 300 deg F (60 and 149 deg C). Consult coating manufacturer for appropriate coating materials and application methods for operating temperature range.
 - 2. Carbon Steel: Coat carbon steel operating at a service temperature between 32 and 300 deg F (0 and 149 deg C) with an epoxy coating. Consult coating manufacturer for appropriate coating materials and application methods for operating temperature range.

- C. Coordinate insulation installation with the trade installing heat tracing. Comply with requirements for heat tracing that apply to insulation.
- D. Mix insulating cements with clean potable water; if insulating cements are to be in contact with stainless-steel surfaces, use demineralized water.

3.3 GENERAL INSTALLATION REQUIREMENTS

- A. Install insulation materials, accessories, and finishes with smooth, straight, and even surfaces; free of voids throughout the length of equipment and piping including fittings, valves, and specialties.
- B. Install insulation materials, forms, vapor barriers or retarders, jackets, and thicknesses required for each item of equipment and pipe system as specified in insulation system schedules.
- C. Install accessories compatible with insulation materials and suitable for the service. Install accessories that do not corrode, soften, or otherwise attack insulation or jacket in either wet or dry state.
- D. Install insulation with longitudinal seams at top and bottom of horizontal runs.
- E. Install multiple layers of insulation with longitudinal and end seams staggered.
- F. Do not weld brackets, clips, or other attachment devices to piping, fittings, and specialties.
- G. Keep insulation materials dry during application and finishing.
- H. Install insulation with tight longitudinal seams and end joints. Bond seams and joints with adhesive recommended by insulation material manufacturer.
- I. Install insulation with least number of joints practical.
- J. Where vapor barrier is indicated, seal joints, seams, and penetrations in insulation at hangers, supports, anchors, and other projections with vapor-barrier mastic.
 - 1. Install insulation continuously through hangers and around anchor attachments.
 - 2. For insulation application where vapor barriers are indicated, extend insulation on anchor legs from point of attachment to supported item to point of attachment to structure. Taper and seal ends at attachment to structure with vapor-barrier mastic.
 - 3. Install insert materials and install insulation to tightly join the insert. Seal insulation to insulation inserts with adhesive or sealing compound recommended by insulation material manufacturer.
 - 4. Cover inserts with jacket material matching adjacent pipe insulation. Install shields over jacket, arranged to protect jacket from tear or puncture by hanger, support, and shield.
- K. Apply adhesives, mastics, and sealants at manufacturer's recommended coverage rate and wet and dry film thicknesses.
- L. Install insulation with factory-applied jackets as follows:
 - 1. Draw jacket tight and smooth.
 - 2. Cover circumferential joints with 3-inch- (75-mm-) wide strips, of same material as insulation jacket. Secure strips with adhesive and outward clinching staples along both edges of strip, spaced 4 inches (100 mm) o.c.

3. Overlap jacket longitudinal seams at least 1-1/2 inches (38 mm). Install insulation with longitudinal seams at bottom of pipe. Clean and dry surface to receive self-sealing lap. Staple laps with outward clinching staples along edge at 2 inches (50 mm) o.c.
 - a. For below ambient services, apply vapor-barrier mastic over staples.
 4. Cover joints and seams with tape as recommended by insulation material manufacturer to maintain vapor seal.
 5. Where vapor barriers are indicated, apply vapor-barrier mastic on seams and joints and at ends adjacent to pipe flanges and fittings.
- M. Cut insulation in a manner to avoid compressing insulation more than 75 percent of its nominal thickness.
- N. Finish installation with systems at operating conditions. Repair joint separations and cracking due to thermal movement.
- O. Repair damaged insulation facings by applying same facing material over damaged areas. Extend patches at least 4 inches (100 mm) beyond damaged areas. Adhere, staple, and seal patches similar to butt joints.
- P. For above ambient services, do not install insulation to the following:
1. Vibration-control devices.
 2. Testing agency labels and stamps.
 3. Nameplates and data plates.
 4. Manholes.
 5. Handholes.
 6. Cleanouts.

3.4 PENETRATIONS

- A. Insulation Installation at Roof Penetrations: Install insulation continuously through roof penetrations.
1. Seal penetrations with flashing sealant.
 2. For applications requiring only indoor insulation, terminate insulation above roof surface and seal with joint sealant. For applications requiring indoor and outdoor insulation, install insulation for outdoor applications tightly joined to indoor insulation ends. Seal joint with joint sealant.
 3. Extend jacket of outdoor insulation outside roof flashing at least 2 inches (50 mm) below top of roof flashing.
 4. Seal jacket to roof flashing with flashing sealant.
- B. Insulation Installation at Aboveground Exterior Wall Penetrations: Install insulation continuously through wall penetrations.
1. Seal penetrations with flashing sealant.
 2. For applications requiring only indoor insulation, terminate insulation inside wall surface and seal with joint sealant. For applications requiring indoor and outdoor insulation, install insulation for outdoor applications tightly joined to indoor insulation ends. Seal joint with joint sealant.
 3. Extend jacket of outdoor insulation outside wall flashing and overlap wall flashing at least 2 inches (50 mm).
 4. Seal jacket to wall flashing with flashing sealant.
- C. Insulation Installation at Interior Wall and Partition Penetrations (That Are Not Fire Rated): Install insulation continuously through walls and partitions.

- D. Insulation Installation at Fire-Rated Wall and Partition Penetrations: Install insulation continuously through penetrations of fire-rated walls and partitions.
 - 1. Comply with requirements in Division 07 Section "Penetration Firestopping" firestopping and fire-resistive joint sealers.
- E. Insulation Installation at Floor Penetrations:
 - 1. Pipe: Install insulation continuously through floor penetrations.
 - 2. Seal penetrations through fire-rated assemblies. Comply with requirements in Division 07 Section "Penetration Firestopping."

3.5 EQUIPMENT, TANK, AND VESSEL INSULATION INSTALLATION

- A. Mineral Fiber, Pipe and Tank Insulation Installation for Tanks and Vessels: Secure insulation with adhesive and anchor pins and speed washers.
 - 1. Apply adhesives according to manufacturer's recommended coverage rates per unit area, for 100percent coverage of tank and vessel surfaces.
 - 2. Groove and score insulation materials to fit as closely as possible to equipment, including contours. Bevel insulation edges for cylindrical surfaces for tight joints. Stagger end joints.
 - 3. Protect exposed corners with secured corner angles.
 - 4. Install adhesively attached or self-sticking insulation hangers and speed washers on sides of tanks and vessels as follows:
 - a. Do not weld anchor pins to ASME-labeled pressure vessels.
 - b. Select insulation hangers and adhesive that are compatible with service temperature and with substrate.
 - c. On tanks and vessels, maximum anchor-pin spacing is 3 inches (75 mm) from insulation end joints, and 16 inches (400 mm) o.c. in both directions.
 - d. Do not overcompress insulation during installation.
 - e. Cut and miter insulation segments to fit curved sides and domed heads of tanks and vessels.
 - f. Impale insulation over anchor pins and attach speed washers.
 - g. Cut excess portion of pins extending beyond speed washers or bend parallel with insulation surface. Cover exposed pins and washers with tape matching insulation facing.
 - 5. Secure each layer of insulation with stainless-steel or aluminum bands. Select band material compatible with insulation materials.
 - 6. Where insulation hangers on equipment and vessels are not permitted or practical and where insulation support rings are not provided, install a girdle network for securing insulation. Stretch prestressed aircraft cable around the diameter of vessel and make taut with clamps, turnbuckles, or breather springs. Place one circumferential girdle around equipment approximately 6 inches (150 mm) from each end. Install wire or cable between two circumferential girdles 12 inches (300 mm) o.c. Install a wire ring around each end and around outer periphery of center openings, and stretch prestressed aircraft cable radially from the wire ring to nearest circumferential girdle. Install additional circumferential girdles along the body of equipment or tank at a minimum spacing of 48 inches (1200 mm) o.c. Use this network for securing insulation with tie wire or bands.
 - 7. Stagger joints between insulation layers at least 3 inches (75 mm).
 - 8. Install insulation in removable segments on equipment access doors, manholes, handholes, and other elements that require frequent removal for service and inspection.

9. Bevel and seal insulation ends around manholes, handholes, ASME stamps, and nameplates.
 10. For equipment with surface temperatures below ambient, apply mastic to open ends, joints, seams, breaks, and punctures in insulation.
- B. Flexible Elastomeric Thermal Insulation Installation for Tanks and Vessels: Install insulation over entire surface of tanks and vessels.
1. Apply 100 percent coverage of adhesive to surface with manufacturer's recommended adhesive.
 2. Seal longitudinal seams and end joints.

3.6 GENERAL PIPE INSULATION INSTALLATION

- A. Requirements in this article generally apply to all insulation materials except where more specific requirements are specified in various pipe insulation material installation articles.
- B. Insulation Installation on Fittings, Valves, Strainers, Flanges, and Unions:
1. Install insulation over fittings, valves, strainers, flanges, unions, and other specialties with continuous thermal and vapor-retarder integrity, unless otherwise indicated.
 2. Insulate pipe elbows using preformed fitting insulation or mitered fittings made from same material and density as adjacent pipe insulation. Each piece shall be butted tightly against adjoining piece and bonded with adhesive. Fill joints, seams, voids, and irregular surfaces with insulating cement finished to a smooth, hard, and uniform contour that is uniform with adjoining pipe insulation.
 3. Insulate tee fittings with preformed fitting insulation or sectional pipe insulation of same material and thickness as used for adjacent pipe. Cut sectional pipe insulation to fit. Butt each section closely to the next and hold in place with tie wire. Bond pieces with adhesive.
 4. Insulate valves using preformed fitting insulation or sectional pipe insulation of same material, density, and thickness as used for adjacent pipe. Overlap adjoining pipe insulation by not less than two times the thickness of pipe insulation, or one pipe diameter, whichever is thicker. For valves, insulate up to and including the bonnets, valve stuffing-box studs, bolts, and nuts. Fill joints, seams, and irregular surfaces with insulating cement.
 5. Insulate strainers using preformed fitting insulation or sectional pipe insulation of same material, density, and thickness as used for adjacent pipe. Overlap adjoining pipe insulation by not less than two times the thickness of pipe insulation, or one pipe diameter, whichever is thicker. Fill joints, seams, and irregular surfaces with insulating cement. Insulate strainers so strainer basket flange or plug can be easily removed and replaced without damaging the insulation and jacket. Provide a removable reusable insulation cover. For below ambient services, provide a design that maintains vapor barrier.
 6. Insulate flanges and unions using a section of oversized preformed pipe insulation. Overlap adjoining pipe insulation by not less than two times the thickness of pipe insulation, or one pipe diameter, whichever is thicker.
 7. Cover segmented insulated surfaces with a layer of finishing cement and coat with a mastic. Install vapor-barrier mastic for below ambient services and a breather mastic for above ambient services. Reinforce the mastic with fabric-reinforcing mesh. Trowel the mastic to a smooth and well-shaped contour.

8. For services not specified to receive a field-applied jacket except for flexible elastomeric and polyolefin, install fitted PVC cover over elbows, tees, strainers, valves, flanges, and unions. Terminate ends with PVC end caps. Tape PVC covers to adjoining insulation facing using PVC tape.
 9. Stencil or label the outside insulation jacket of each union with the word "UNION." Match size and color of pipe labels.
- C. Insulate instrument connections for thermometers, pressure gages, pressure temperature taps, test connections, flow meters, sensors, switches, and transmitters on insulated pipes, vessels, and equipment. Shape insulation at these connections by tapering it to and around the connection with insulating cement and finish with finishing cement, mastic, and flashing sealant.
- D. Install removable insulation covers at locations indicated. Installation shall conform to the following:
1. Make removable flange and union insulation from sectional pipe insulation of same thickness as that on adjoining pipe. Install same insulation jacket as adjoining pipe insulation.
 2. When flange and union covers are made from sectional pipe insulation, extend insulation from flanges or union long at least two times the insulation thickness over adjacent pipe insulation on each side of flange or union. Secure flange cover in place with stainless-steel or aluminum bands. Select band material compatible with insulation and jacket.
 3. Construct removable valve insulation covers in same manner as for flanges except divide the two-part section on the vertical center line of valve body.
 4. When covers are made from block insulation, make two halves, each consisting of mitered blocks wired to stainless-steel fabric. Secure this wire frame, with its attached insulation, to flanges with tie wire. Extend insulation at least 2 inches (50 mm) over adjacent pipe insulation on each side of valve. Fill space between flange or union cover and pipe insulation with insulating cement. Finish cover assembly with insulating cement applied in two coats. After first coat is dry, apply and trowel second coat to a smooth finish.
 5. Unless a PVC jacket is indicated in field-applied jacket schedules, finish exposed surfaces with a metal jacket.

3.7 FLEXIBLE ELASTOMERIC INSULATION INSTALLATION

- A. Seal longitudinal seams and end joints with manufacturer's recommended adhesive to eliminate openings in insulation that allow passage of air to surface being insulated.
- B. Insulation Installation on Pipe Flanges:
1. Install pipe insulation to outer diameter of pipe flange.
 2. Make width of insulation section same as overall width of flange and bolts, plus twice the thickness of pipe insulation.
 3. Fill voids between inner circumference of flange insulation and outer circumference of adjacent straight pipe segments with cut sections of sheet insulation of same thickness as pipe insulation.
 4. Secure insulation to flanges and seal seams with manufacturer's recommended adhesive to eliminate openings in insulation that allow passage of air to surface being insulated.
- C. Insulation Installation on Pipe Fittings and Elbows:
1. Install mitered sections of pipe insulation.

2. Secure insulation materials and seal seams with manufacturer's recommended adhesive to eliminate openings in insulation that allow passage of air to surface being insulated.

D. Insulation Installation on Valves and Pipe Specialties:

1. Install preformed valve covers manufactured of same material as pipe insulation when available.
2. When preformed valve covers are not available, install cut sections of pipe and sheet insulation to valve body. Arrange insulation to permit access to packing and to allow valve operation without disturbing insulation.
3. Install insulation to flanges as specified for flange insulation application.
4. Secure insulation to valves and specialties and seal seams with manufacturer's recommended adhesive to eliminate openings in insulation that allow passage of air to surface being insulated.

3.8 MINERAL-FIBER INSULATION INSTALLATION

A. Insulation Installation on Straight Pipes and Tubes:

1. Secure each layer of preformed pipe insulation to pipe with wire or bands and tighten bands without deforming insulation materials.
2. Where vapor barriers are indicated, seal longitudinal seams, end joints, and protrusions with vapor-barrier mastic and joint sealant.
3. For insulation with factory-applied jackets on above ambient surfaces, secure laps with outward clinched staples at 6 inches (150 mm) o.c.
4. For insulation with factory-applied jackets on below ambient surfaces, do not staple longitudinal tabs but secure tabs with additional adhesive as recommended by insulation material manufacturer and seal with vapor-barrier mastic and flashing sealant.

B. Insulation Installation on Pipe Flanges:

1. Install preformed pipe insulation to outer diameter of pipe flange.
2. Make width of insulation section same as overall width of flange and bolts, plus twice the thickness of pipe insulation.
3. Fill voids between inner circumference of flange insulation and outer circumference of adjacent straight pipe segments with mineral-fiber blanket insulation.
4. Install jacket material with manufacturer's recommended adhesive, overlap seams at least 1 inch (25 mm), and seal joints with flashing sealant.

C. Insulation Installation on Pipe Fittings and Elbows:

1. Install preformed sections of same material as straight segments of pipe insulation when available.
2. When preformed insulation elbows and fittings are not available, install mitered sections of pipe insulation, to a thickness equal to adjoining pipe insulation. Secure insulation materials with wire or bands.

D. Insulation Installation on Valves and Pipe Specialties:

1. Install preformed sections of same material as straight segments of pipe insulation when available.
2. When preformed sections are not available, install mitered sections of pipe insulation to valve body.
3. Arrange insulation to permit access to packing and to allow valve operation without disturbing insulation.
4. Install insulation to flanges as specified for flange insulation application.

3.9 FIELD-APPLIED JACKET INSTALLATION

- A. Where PVC jackets are indicated, install with 1-inch (25-mm) overlap at longitudinal seams and end joints; for horizontal applications, install with longitudinal seams along top and bottom of tanks and vessels. Seal with manufacturer's recommended adhesive.
 - 1. Apply two continuous beads of adhesive to seams and joints, one bead under lap and the finish bead along seam and joint edge.
- B. Where metal jackets are indicated, install with 2-inch (50-mm) overlap at longitudinal seams and end joints. Overlap longitudinal seams arranged to shed water. Seal end joints with weatherproof sealant recommended by insulation manufacturer. Secure jacket with stainless-steel bands 12 inches (300 mm) o.c. and at end joints.

3.10 FINISHES

- A. Equipment and Pipe Insulation with ASJ, or Other Paintable Jacket Material: Paint jacket with paint system identified below and as specified in Division 09 painting Sections.
 - 1. Flat Acrylic Finish: Twofinish coats over a primer that is compatible with jacket material and finish coat paint. Add fungicidal agent to render fabric mildew proof.
 - a. Finish Coat Material: Interior, flat, latex-emulsion size.
- B. Flexible Elastomeric Thermal Insulation: After adhesive has fully cured, apply two coats of insulation manufacturer's recommended protective coating.
- C. Color: Final color as selected by Architect. Vary first and second coats to allow visual inspection of the completed Work.
- D. Do not field paint aluminum or stainless-steel jackets.

3.11 FIELD QUALITY CONTROL

- A. Testing Agency: Engage a qualified testing agency to perform tests and inspections.
- B. Perform tests and inspections.
- C. Tests and Inspections:
 - 1. Inspect field-insulated equipment, randomly selected by Architect, by removing field-applied jacket and insulation in layers in reverse order of their installation. Extent of inspection shall be limited to one location(s) for each type of equipment defined in the "Equipment Insulation Schedule" Article. For large equipment, remove only a portion adequate to determine compliance.
 - 2. Inspect pipe, fittings, strainers, and valves, randomly selected by Architect, by removing field-applied jacket and insulation in layers in reverse order of their installation. Extent of inspection shall be limited to three locations of straight pipe, three locations of threaded fittings, three locations of welded fittings, locations of threaded strainers, locations of welded strainers, three locations of threaded valves, and three locations of flanged valves for each pipe service defined in the "Piping Insulation Schedule, General" Article.
- D. All insulation applications will be considered defective Work if sample inspection reveals noncompliance with requirements.

3.12 EQUIPMENT INSULATION SCHEDULE

- A. Insulation materials and thicknesses are identified below. If more than one material is listed for a type of equipment, selection from materials listed is Contractor's option.
- B. Insulate indoor and outdoor equipment in paragraphs below that is not factory insulated.
- C. Domestic hot-water hydropneumatic tank insulation shall be the following:
 - 1. Mineral-Fiber Pipe and Tank: 1 inch (25 mm) thick.
- D. Domestic hot-water storage tank insulation shall be the following:
 - 1. Mineral-Fiber Pipe and Tank: 4 inches (100 mm) thick.
- E. Domestic water storage tank insulation shall be the following:
 - 1. Flexible Elastomeric: 1 inch (25 mm) thick.
 - 2. Mineral-Fiber Board: 1 inch (25 mm) thick and 3-lb/cu. ft. (48-kg/cu. m) nominal density.
 - 3. Mineral-Fiber Pipe and Tank: 1 inch (25 mm) thick.
- F. Piping system filter-housing insulation shall be the following:
 - 1. Mineral-Fiber Board: 2 inches (50 mm) thick and 3-lb/cu. ft. (48-kg/cu. m) nominal density.
 - 2. Mineral-Fiber Pipe and Tank: 2 inches (50 mm) thick.

3.13 PIPING INSULATION SCHEDULE, GENERAL

- A. Acceptable preformed pipe and tubular insulation materials and thicknesses are identified for each piping system and pipe size range. If more than one material is listed for a piping system, selection from materials listed is Contractor's option.
- B. Items Not Insulated: Unless otherwise indicated, do not install insulation on the following:
 - 1. Drainage piping located in crawl spaces.
 - 2. Underground piping.
 - 3. Chrome-plated pipes and fittings unless there is a potential for personnel injury.

3.14 INDOOR PIPING INSULATION SCHEDULE

- A. Domestic Cold Water:
 - 1. NPS 1 (DN 25) and Smaller: Insulation shall be the following:
 - a. Mineral-Fiber, Preformed Pipe Insulation, Type I: 1/2 inch (13 mm) thick.
 - 2. NPS 1-1/4 (DN 32) and Larger: Insulation shall be the following:
 - a. Mineral-Fiber, Preformed Pipe Insulation, Type I: 1 inch (25 mm) thick.
- B. Domestic Hot and Recirculated Hot Water:
 - 1. NPS 1-1/4 (DN 32) and Smaller: Insulation shall be the following:
 - a. Mineral-Fiber, Preformed Pipe Insulation, Type I: 1 inch (25 mm) thick.
 - 2. NPS 1-1/2 (DN 40) and Larger: Insulation shall be the following:
 - a. Mineral-Fiber, Preformed Pipe Insulation, Type I: 1.5 inch (38 mm) thick.
- C. Domestic Chilled Water (Potable):
 - 1. All Pipe Sizes: Insulation shall be the following:

- a. Mineral-Fiber, Preformed Pipe Insulation, Type I: 1 inch (25 mm) thick.
- D. Stormwater and Overflow:
 - 1. All Pipe Sizes: Insulation shall be the following:
 - a. Mineral-Fiber, Preformed Pipe Insulation, Type I: 1 inch (25 mm) thick.
- E. Roof Drain and Overflow Drain Bodies and Horizontal Offsets:
 - 1. All Pipe Sizes: Insulation shall be the following:
 - a. Mineral-Fiber, Preformed Pipe Insulation, Type I: 1 inch (25 mm) thick.
- F. Exposed Sanitary Drains, Domestic Water, Domestic Hot Water, and Stops for Plumbing Fixtures for People with Disabilities:
 - 1. All Pipe Sizes: Insulation shall be the following:
 - a. Flexible Elastomeric: 1/2 inch (13 mm) thick.
- G. Sanitary Waste Piping Where Heat Tracing Is Installed:
 - 1. All Pipe Sizes: Insulation shall be the following:
 - a. Mineral-Fiber, Preformed Pipe Insulation, Type I: 1-1/2 inches (38 mm) thick.
- H. Condensate and Equipment Drain Water below 60 Deg F (16 Deg C):
 - 1. All Pipe Sizes: Insulation shall be the following:
 - a. Flexible Elastomeric: 1 inch (25 mm) thick.
- I. Floor Drains, Traps, and Sanitary Drain Piping within 10 Feet (3 m) of Drain Receiving Condensate and Equipment Drain Water below 60 Deg F (16 Deg C):
 - 1. All Pipe Sizes: Insulation shall be the following:
 - a. Mineral-Fiber, Preformed Pipe Insulation, Type I: 1/2 inch (13 mm) thick.

3.15 OUTDOOR, ABOVEGROUND PIPING INSULATION SCHEDULE

- A. Domestic Water Piping:
 - 1. All Pipe Sizes: Insulation shall be the following:
 - a. Mineral-Fiber, Preformed Pipe Insulation, Type I: 2 inches (50 mm) thick.
- B. Domestic Hot and Recirculated Hot Water:
 - 1. All Pipe Sizes: Insulation shall be the following:
 - a. Mineral-Fiber, Preformed Pipe Insulation, Type I: 2 inches (50 mm) thick.
- C. Sanitary Waste Piping Where Heat Tracing Is Installed:
 - 1. All Pipe Sizes: Insulation shall be the following:
 - a. Mineral-Fiber, Preformed Pipe Insulation, Type I: 2 inches (50 mm) thick.

3.16 OUTDOOR, UNDERGROUND PIPING INSULATION SCHEDULE

- A. Loose-fill insulation, for belowground piping, is specified in Division 33 piping distribution Sections.

3.17 INDOOR, FIELD-APPLIED JACKET SCHEDULE

- A. Install jacket over insulation material. For insulation with factory-applied jacket, install the field-applied jacket over the factory-applied jacket.

- B. If more than one material is listed, selection from materials listed is Contractor's option.
- C. Piping, Exposed:
 - 1. None.
 - 2. PVC: 20 mils (0.5 mm) thick.

3.18 OUTDOOR, FIELD-APPLIED JACKET SCHEDULE

- A. Install jacket over insulation material. For insulation with factory-applied jacket, install the field-applied jacket over the factory-applied jacket.
- B. If more than one material is listed, selection from materials listed is Contractor's option.
- C. Piping, Exposed:
 - 1. Aluminum, Corrugated with Z-Shaped Locking Seam: 0.020 inch (0.51 mm) thick.

3.19 UNDERGROUND, FIELD-INSTALLED INSULATION JACKET

- A. For underground direct-buried piping applications, install underground direct-buried jacket over insulation material.

END OF SECTION

This page is intentionally left blank.

Section 22 11 16

DOMESTIC WATER PIPING

PART 1 - GENERAL

1.1 RELATED DOCUMENTS

- A. Drawings and general provisions of the Contract, including General and Supplementary Conditions and Division 01 Specification Sections, apply to this Section.
- B. Section 01 81 13 "Sustainable Design Requirements – LEED v4 for Building Design & Construction – New Construction" for sustainable design requirements and detailed sustainable design submittal requirements.
- C. Section 01 74 19 "Construction and Demolition Waste Management and Disposal" for disposal of construction, demolition and packaging waste disposal requirements.

1.2 SUMMARY

- A. Section Includes:
 - 1. Under-building slab and aboveground domestic water pipes, tubes, fittings, and specialties inside the building.
 - 2. Encasement for piping.
 - 3. Specialty valves.
 - 4. Flexible connectors.
 - 5. Water meters furnished by utility company for installation by Contractor.
 - 6. Water meters.
 - 7. Escutcheons.
 - 8. Sleeves and sleeve seals.
 - 9. Wall penetration systems.
- B. Related Section:
 - 1. Division 22 Section "Facility Water Distribution Piping" for water-service piping outside the building from source to the point where water-service piping enters the building.
- C. Sustainable Building Requirements:
 - 1. The Owner requires the Contractor to implement practices and procedures to meet the project's environmental performance goals, which include achieving LEED version 4 **Certified** level Certification. Specific project goals that may impact this area of work include: use of recycled-content materials; use of locally-manufactured materials; use of low-emitting materials; construction waste recycling; and the implementation of a construction indoor air quality management plan. The Contractor shall ensure that the requirements related to these goals, as defined in the Articles below, are implemented to the fullest extent. Substitutions, or other changes to the work proposed by the Contractor or their Subcontractors, shall not be allowed if such changes compromise the aforementioned environmental goals and LEED certification.

1.3 PERFORMANCE REQUIREMENTS

- A. Seismic Performance: Domestic water piping and support and installation shall withstand effects of earthquake motions determined according to SEI/ASCE 7.

1.4 SUBMITTALS

- A. Product Data: For the following products:
 - 1. Specialty valves.
 - 2. Transition fittings.
 - 3. Dielectric fittings.
 - 4. Flexible connectors.
 - 5. Water meters.
 - 6. Backflow preventers and vacuum breakers.
 - 7. Escutcheons.
 - 8. Sleeves and sleeve seals.
 - 9. Water penetration systems.
- B. Water Samples: Specified in "Cleaning" Article.
- C. Coordination Drawings: For piping in equipment rooms and other congested areas, drawn to scale, on which the following items are shown and coordinated with each other, using input from Installers of the items involved:
 - 1. Fire-suppression-water piping.
 - 2. Domestic water piping.
 - 3. Natural gas piping.
 - 4. Medical gas and vacuum piping.
 - 5. Compressed air piping.
 - 6. HVAC hydronic piping.
- D. Field quality-control reports.

1.5 QUALITY ASSURANCE

- A. Piping materials shall bear label, stamp, or other markings of specified testing agency.
- B. Comply with NSF 61 for potable domestic water piping and components.

1.6 PROJECT CONDITIONS

- A. Interruption of Existing Water Service: Do not interrupt water service to facilities occupied by Owner or others unless permitted under the following conditions and then only after arranging to provide temporary water service according to requirements indicated:
 - 1. Notify Ownerno fewer than five days in advance of proposed interruption of water service.
 - 2. Do not proceed with interruption of water service without Owner'swritten permission.

1.7 COORDINATION

- A. Coordinate sizes and locations of concrete bases with actual equipment provided.

PART 2 - PRODUCTS

2.1 PIPING MATERIALS

- A. Comply with requirements in "Piping Schedule" Article for applications of pipe, tube, fitting materials, and joining methods for specific services, service locations, and pipe sizes.

2.2 COPPER TUBE AND FITTINGS

- A. Hard Copper Tube: ASTM B 88, Type L (ASTM B 88M, Type B) water tube, drawn temper.
 - 1. Cast-Copper Solder-Joint Fittings: ASME B16.18, pressure fittings.
 - 2. Wrought-Copper Solder-Joint Fittings: ASME B16.22, wrought-copper pressure fittings.
 - 3. Bronze Flanges: ASME B16.24, Class 150, with solder-joint ends.
 - 4. Copper Unions: MSS SP-123, cast-copper-alloy, hexagonal-stock body, with ball-and-socket, metal-to-metal seating surfaces, and solder-joint or threaded ends.
 - 5. Grooved-Joint Copper-Tube Appurtenances:
 - a. Manufacturers: Subject to compliance with requirements, provide products by one of the following:
 - 1) Victaulic Company.
 - b. Copper Grooved-End Fittings: ASTM B 75 (ASTM B 75M) copper tube or ASTM B 584 bronze castings.
 - c. Grooved-End-Tube Couplings: Copper-tube dimensions and design similar to AWWA C606. Include ferrous housing sections, EPDM-rubber gaskets suitable for hot and cold water, and bolts and nuts.
- B. Soft Copper Tube: ASTM B 88, Type L (ASTM B 88M, Type B) water tube, annealed temper.
 - 1. Copper Solder-Joint Fittings: ASME B16.22, wrought-copper pressure fittings.

2.3 DUCTILE-IRON PIPE AND FITTINGS

- A. Mechanical-Joint, Ductile-Iron Pipe: AWWA C151, with mechanical-joint bell and plain spigot end unless grooved or flanged ends are indicated.
 - 1. Standard-Pattern, Mechanical-Joint Fittings: AWWA C110, ductile or gray iron.
 - 2. Compact-Pattern, Mechanical-Joint Fittings: AWWA C153, ductile iron.
 - a. Glands, Gaskets, and Bolts: AWWA C111, ductile- or gray-iron glands, rubber gaskets, and steel bolts.
- B. Push-on-Joint, Ductile-Iron Pipe: AWWA C151, with push-on-joint bell and plain spigot end unless grooved or flanged ends are indicated.
 - 1. Standard-Pattern, Push-on-Joint Fittings: AWWA C110, ductile or gray iron.
 - a. Gaskets: AWWA C111, rubber.
 - 2. Compact-Pattern, Push-on-Joint Fittings: AWWA C153, ductile iron.
 - a. Gaskets: AWWA C111, rubber.

2.4 GALVANIZED-STEEL PIPE AND FITTINGS

- A. Galvanized-Steel Pipe: ASTM A 53/A 53M, Type E, Grade B, Standard Weight. Include ends matching joining method.
 - 1. Galvanized-Steel Pipe Nipples: ASTM A 733, made of ASTM A 53/A 53M or ASTM A 106/A 106M, Standard Weight, seamless steel pipe with threaded ends.
 - 2. Galvanized, Gray-Iron Threaded Fittings: ASME B16.4, Class 125, standard pattern.
 - 3. Malleable-Iron Unions: ASME B16.39, Class 150, hexagonal-stock body with ball-and-socket, metal-to-metal, bronze seating surface, and female threaded ends.
 - 4. Flanges: ASME B16.1, Class 125, cast iron.
 - 5. Grooved-Joint, Galvanized-Steel-Pipe Appurtenances:
 - a. Manufacturers: Subject to compliance with requirements, provide products by one of the following:
 - 1) Victaulic Company.
 - b. Galvanized, Grooved-End Fittings for Galvanized-Steel Piping: ASTM A 47/A 47M, malleable-iron casting; ASTM A 106/A 106M, steel pipe; or ASTM A 536, ductile-iron casting; with dimensions matching steel pipe.
 - c. Grooved-End-Pipe Couplings for Galvanized-Steel Piping: AWWA C606 for steel-pipe dimensions. Include ferrous housing sections, EPDM-rubber gaskets suitable for hot and cold water, and bolts and nuts.

2.5 PIPING JOINING MATERIALS

- A. Pipe-Flange Gasket Materials: AWWA C110, rubber, flat face, 1/8 inch (3.2 mm) thick or ASME B16.21, nonmetallic and asbestos free, unless otherwise indicated; full-face or ring type unless otherwise indicated.
- B. Metal, Pipe-Flange Bolts and Nuts: ASME B18.2.1, carbon steel unless otherwise indicated.
- C. Solder Filler Metals: ASTM B 32, lead-free alloys. Include water-flushable flux according to ASTM B 813.
- D. Brazing Filler Metals: AWS A5.8/A5.8M, BCuP Series, copper-phosphorus alloys for general-duty brazing unless otherwise indicated.

2.6 ENCASUREMENT FOR PIPING

- A. Standard: ASTM A 674 or AWWA C105.
- B. Form: Sheet or Tube.
- C. Material: High-density, cross-laminated PE film of 0.004-inch (0.10-mm) minimum thickness.
- D. Color: Black.

2.7 SPECIALTY VALVES

- A. Comply with requirements in Division 22 Section "General-Duty Valves for Plumbing Piping" for general-duty metal valves.

- B. Comply with requirements in Division 22 Section "Domestic Water Piping Specialties" for balancing valves, drain valves, backflow preventers, and vacuum breakers.

2.8 TRANSITION FITTINGS

- A. General Requirements:
 - 1. Same size as pipes to be joined.
 - 2. Pressure rating at least equal to pipes to be joined.
 - 3. End connections compatible with pipes to be joined.
- B. Fitting-Type Transition Couplings: Manufactured piping coupling or specified piping system fitting.
- C. Sleeve-Type Transition Coupling: AWWA C219.
 - 1. Manufacturers: Subject to compliance with requirements, provide products by one of the following:
 - a. Dresser, Inc.; Dresser Piping Specialties.
 - b. Ford Meter Box Company, Inc. (The).
 - c. Romac Industries, Inc.
 - d. Smith-Blair, Inc; a Sensus company.
 - e. Viking Johnson; c/o Mueller Co.

2.9 DIELECTRIC FITTINGS

- A. General Requirements: Assembly of copper alloy and ferrous materials or ferrous material body with separating nonconductive insulating material suitable for system fluid, pressure, and temperature.
- B. Dielectric Unions:
 - 1. Manufacturers: Subject to compliance with requirements, provide products by one of the following:
 - a. Watts Regulator Co.; a division of Watts Water Technologies, Inc.
 - b. Zurn Plumbing Products Group; Wilkins Water Control Products.
 - 2. Description:
 - a. Pressure Rating: 150 psig (1035 kPa) at 180 deg F (82 deg C).
 - b. End Connections: Solder-joint copper alloy and threaded ferrous.
- C. Dielectric Flanges:
 - 1. Manufacturers: Subject to compliance with requirements, provide products by one of the following:
 - a. Watts Regulator Co.; a division of Watts Water Technologies, Inc.
 - 2. Description:
 - a. Factory-fabricated, bolted, companion-flange assembly.
 - b. Pressure Rating: 175 psig (1200 kPa) minimum.
 - c. End Connections: Solder-joint copper alloy and threaded ferrous; threaded solder-joint copper alloy and threaded ferrous.
- D. Dielectric-Flange Kits:
 - 1. Manufacturers: Subject to compliance with requirements, provide products by one of the following:
 - a. Calpico, Inc.
 - 2. Description:
 - a. Nonconducting materials for field assembly of companion flanges.

- b. Pressure Rating: 150 psig (1035 kPa).
 - c. Gasket: Neoprene or phenolic.
 - d. Bolt Sleeves: Phenolic or polyethylene.
 - e. Washers: Phenolic with steel backing washers.
- E. Dielectric Couplings:
- 1. Manufacturers: Subject to compliance with requirements, provide products by one of the following:
 - a. Calpico, Inc.
 - b. Lochinvar Corporation.
 - 2. Description:
 - a. Galvanized-steel coupling.
 - b. Pressure Rating: 300 psig (2070 kPa) at 225 deg F (107 deg C).
 - c. End Connections: Female threaded.
 - d. Lining: Inert and noncorrosive, thermoplastic.
- F. Dielectric Nipples:
- 1. Manufacturers: Subject to compliance with requirements, provide products by one of the following:
 - a. Precision Plumbing Products, Inc.
 - b. Victaulic Company.
 - 2. Description:
 - a. Electroplated steel nipple complying with ASTM F 1545.
 - b. Pressure Rating: 300 psig (2070 kPa) at 225 deg F (107 deg C).
 - c. End Connections: Male threaded or grooved.
 - d. Lining: Inert and noncorrosive, propylene.
- 2.10 FLEXIBLE CONNECTORS
- A. Manufacturers: Subject to compliance with requirements, provide products by one of the following:
- 1. Mercer Rubber Co.
 - 2. Metraflex, Inc.
 - 3. Tozen Corporation.
 - 4. Universal Metal Hose; a Hyspan company
- B. Bronze-Hose Flexible Connectors: Corrugated-bronze tubing with bronze wire-braid covering and ends brazed to inner tubing.
- 1. Working-Pressure Rating: Minimum 200 psig (1380 kPa).
 - 2. End Connections NPS 2 (DN 50) and Smaller: Threaded copper pipe or plain-end copper tube.
 - 3. End Connections NPS 2-1/2 (DN 65) and Larger: Flanged copper alloy.
- C. Stainless-Steel-Hose Flexible Connectors: Corrugated-stainless-steel tubing with stainless-steel wire-braid covering and ends welded to inner tubing.
- 1. Working-Pressure Rating: Minimum 200 psig (1380 kPa).
 - 2. End Connections NPS 2 (DN 50) and Smaller: Threaded steel-pipe nipple.
 - 3. End Connections NPS 2-1/2 (DN 65) and Larger: Flanged steel nipple.
- 2.11 WATER METERS
- A. Compound-Type Water Meters:

1. Manufacturers: Subject to compliance with requirements, provide products by one of the following:
 - a. ABB.
 - b. Badger Meter, Inc.
 - c. Mueller Company; Water Products Division.
 - d. Schlumberger Limited; Water Division.
 - e. Sensus Metering Systems.
 2. Description:
 - a. Standard: AWWA C702.
 - b. Pressure Rating: 150-psig (1035-kPa) working pressure.
 - c. Body Design: With integral mainline and bypass meters; totalization meter.
 - d. Registration: In gallons (liters) or cubic feet (cubic meters) as required by utility company.
 - e. Case: Bronze.
 - f. Pipe Connections: Flanged.
- B. Remote Registration System: Direct-reading type complying with AWWA C706; modified with signal transmitting assembly, low-voltage connecting wiring, and remote register assembly as required by utility company.
- 2.12 ESCUTCHEONS
- A. General: Manufactured ceiling, floor, and wall escutcheons and floor plates.
 - B. One Piece, Cast Brass: Polished, chrome-plated finish with setscrews.
 - C. One Piece, Deep Pattern: Deep-drawn, box-shaped brass with chrome-plated finish.
 - D. Split Casting, Cast Brass: Polished, chrome-plated finish with concealed hinge and setscrew.
 - E. One-Piece Floor Plates: Cast-iron flange with holes for fasteners.
 - F. Split-Casting Floor Plates: Cast brass with concealed hinge.
- 2.13 SLEEVES
- A. Cast-Iron Wall Pipes: Fabricated of cast iron, and equivalent to ductile-iron pressure pipe, with plain ends and integral waterstop unless otherwise indicated.
 - B. Galvanized-Steel-Sheet Sleeves: 0.0239-inch (0.6-mm) minimum thickness; round tube closed with welded longitudinal joint.
 - C. Molded-PE Sleeves: Reusable, PE, tapered-cup shaped, and smooth outer surface with nailing flange for attaching to wooden forms.
 - D. Galvanized-Steel-Pipe Sleeves: ASTM A 53/A 53M, Type E, Grade B, Schedule 40, zinc-coated, with plain ends.
 - E. Stack Sleeve Fittings: Manufactured, cast-iron sleeve with integral clamping flange. Include clamping ring and bolts and nuts for membrane flashing.
 1. Underdeck Clamp: Clamping ring with setscrews.

2.14 SLEEVE SEALS

- A. Manufacturers: Subject to compliance with requirements, provide products by one of the following:
 - 1. Calpico, Inc.
 - 2. Metraflex, Inc.
 - 3. Thunderline.
- B. Description: Modular sealing element unit, designed for field assembly, used to fill annular space between pipe and sleeve.
 - 1. Sealing Elements: EPDM-rubber interlocking links shaped to fit surface of pipe. Include type and number required for pipe material and size of pipe.
 - 2. Pressure Plates: Plastic.
 - 3. Connecting Bolts and Nuts: Carbon steel, with corrosion-resistant coating, of length required to secure pressure plates to sealing elements.

2.15 GROUT

- A. Standard: ASTM C 1107, Grade B, post-hardening and volume-adjusting, dry, hydraulic-cement grout.
- B. Characteristics: Nonshrink; recommended for interior and exterior applications.
- C. Design Mix: 5000-psi (34.5-MPa), 28-day compressive strength.
- D. Packaging: Premixed and factory packaged.

PART 3 - EXECUTION

3.1 EARTHWORK

- A. Comply with requirements in Division 31 Section "Earth Moving" for excavating, trenching, and backfilling.

3.2 PIPING INSTALLATION

- A. Drawing plans, schematics, and diagrams indicate general location and arrangement of domestic water piping. Indicated locations and arrangements are used to size pipe and calculate friction loss, expansion, and other design considerations. Install piping as indicated unless deviations to layout are approved on Coordination Drawings.
- B. Install copper tubing under building slab according to CDA's "Copper Tube Handbook."
- C. Install ductile-iron piping under building slab with restrained joints according to AWWA C600 and AWWA M41.
- D. Install underground copper tube and ductile-iron pipe in PE encasement according to ASTM A 674 or AWWA C105.
- E. Install shutoff valve, hose-end drain valve, strainer, pressure gage, and test tee with valve, inside the building at each domestic water service entrance. Comply with requirements in Division 22 Section "Meters and Gages for Plumbing Piping"

for pressure gages and Division 22 Section "Domestic Water Piping Specialties" for drain valves and strainers.

- F. Install shutoff valve immediately upstream of each dielectric fitting.
- G. Install water-pressure-reducing valves downstream from shutoff valves. Comply with requirements in Division 22 Section "Domestic Water Piping Specialties" for pressure-reducing valves.
- H. Install domestic water piping level and plumb.
- I. Rough-in domestic water piping for water-meter installation according to utility company's requirements.
- J. Install seismic restraints on piping. Comply with requirements in Division 22 Section "Vibration and Seismic Controls for Plumbing Piping and Equipment" for seismic-restraint devices.
- K. Install piping concealed from view and protected from physical contact by building occupants unless otherwise indicated and except in equipment rooms and service areas.
- L. Install piping indicated to be exposed and piping in equipment rooms and service areas at right angles or parallel to building walls. Diagonal runs are prohibited unless specifically indicated otherwise.
- M. Install piping above accessible ceilings to allow sufficient space for ceiling panel removal, and coordinate with other services occupying that space.
- N. Install piping adjacent to equipment and specialties to allow service and maintenance.
- O. Install piping to permit valve servicing.
- P. Install nipples, unions, special fittings, and valves with pressure ratings the same as or higher than system pressure rating used in applications below unless otherwise indicated.
- Q. Install piping free of sags and bends.
- R. Install fittings for changes in direction and branch connections.
- S. Install unions in copper tubing at final connection to each piece of equipment, machine, and specialty.
- T. Install pressure gages on suction and discharge piping from each plumbing pump and packaged booster pump. Comply with requirements in Division 22 Section "Meters and Gages for Plumbing Piping" for pressure gages.
- U. Install thermostats in hot-water circulation piping. Comply with requirements in Division 22 Section "Domestic Water Pumps" for thermostats.
- V. Install thermometers on inlet and outlet piping from each water heater. Comply with requirements in Division 22 Section "Meters and Gages for Plumbing Piping" for thermometers.

3.3 JOINT CONSTRUCTION

- A. Ream ends of pipes and tubes and remove burrs. Bevel plain ends of steel pipe.

- B. Remove scale, slag, dirt, and debris from inside and outside of pipes, tubes, and fittings before assembly.
- C. Threaded Joints: Thread pipe with tapered pipe threads according to ASME B1.20.1. Cut threads full and clean using sharp dies. Ream threaded pipe ends to remove burrs and restore full ID. Join pipe fittings and valves as follows:
 - 1. Apply appropriate tape or thread compound to external pipe threads.
 - 2. Damaged Threads: Do not use pipe or pipe fittings with threads that are corroded or damaged.
- D. Brazed Joints: Join copper tube and fittings according to CDA's "Copper Tube Handbook," "Braze Joints" Chapter.
- E. Soldered Joints: Apply ASTM B 813, water-flushable flux to end of tube. Join copper tube and fittings according to ASTM B 828 or CDA's "Copper Tube Handbook."
- F. Copper-Tubing Grooved Joints: Roll groove end of tube. Assemble coupling with housing, gasket, lubricant, and bolts. Join copper tube and grooved-end fittings according to AWWA C606 for roll-grooved joints.
- G. Steel-Piping Grooved Joints: Rollgroove end of pipe. Assemble coupling with housing, gasket, lubricant, and bolts. Join steel pipe and grooved-end fittings according to AWWA C606 for steel-pipe grooved joints.
- H. Flanged Joints: Select appropriate asbestos-free, nonmetallic gasket material in size, type, and thickness suitable for domestic water service. Join flanges with gasket and bolts according to ASME B31.9.
- I. Dissimilar-Material Piping Joints: Make joints using adapters compatible with materials of both piping systems.

3.4 VALVE INSTALLATION

- A. General-Duty Valves: Comply with requirements in Division 22 Section "General-Duty Valves for Plumbing Piping" for valve installations.
- B. Install shutoff valve close to water main on each branch and riser serving plumbing fixtures or equipment, on each water supply to equipment, and on each water supply to plumbing fixtures that do not have supply stops. Use ball or gate valves for piping NPS 2 (DN 50) and smaller. Use gate valves for piping NPS 2-1/2 (DN 65) and larger.
- C. Install drain valves for equipment at base of each water riser, at low points in horizontal piping, and where required to drain water piping. Drain valves are specified in Division 22 Section "Domestic Water Piping Specialties."
 - 1. Hose-End Drain Valves: At low points in water mains, risers, and branches.
 - 2. Stop-and-Waste Drain Valves: Instead of hose-end drain valves where indicated.
- D. Install calibrated balancing valves in each hot-water circulation return branch and discharge side of each pump and circulator. Set calibrated balancing valves partly open to restrict but not stop flow. Comply with requirements in Division 22 Section "Domestic Water Piping Specialties" for calibrated balancing valves.

3.5 TRANSITION FITTING INSTALLATION

- A. Install transition couplings at joints of dissimilar piping.
- B. Transition Fittings in Underground Domestic Water Piping:
 - 1. NPS 1-1/2 (DN 40) and Smaller: Fitting-type coupling.
 - 2. NPS 2 (DN 50) and Larger: Sleeve-type coupling.

3.6 DIELECTRIC FITTING INSTALLATION

- A. Install dielectric fittings in piping at connections of dissimilar metal piping and tubing.
- B. Dielectric Fittings for NPS 2 (DN 50) and Smaller: Use dielectric couplings.
- C. Dielectric Fittings for NPS 2-1/2 to NPS 4 (DN 65 to DN 100): Use dielectric flange kits.
- D. Dielectric Fittings for NPS 5 (DN 125) and Larger: Use dielectric flange kits.

3.7 FLEXIBLE CONNECTOR INSTALLATION

- A. Install flexible connectors in suction and discharge piping connections to each domestic water pump and in suction and discharge manifold connections to each domestic water booster pump.
- B. Install bronze-hose flexible connectors in copper domestic water tubing.
- C. Install stainless-steel-hose flexible connectors in steel domestic water piping.

3.8 WATER METER INSTALLATION

- A. Rough-in domestic water piping for service water meter installation according to utility company's requirements.
- B. Water meters will be furnished and installed by utility company.
- C. Install water meters according to AWWA M6, utility company's requirements, and the following:
- D. Install displacement-type water meters with shutoff valve on water-meter inlet. Install valve on water-meter outlet and valved bypass around meter unless prohibited by authorities having jurisdiction.
- E. Install turbine-type water meters with shutoff valve on water-meter inlet. Install valve on water-meter outlet and valved bypass around meter unless prohibited by authorities having jurisdiction.
- F. Install compound-type water meters with shutoff valves on water-meter inlet and outlet and on valved bypass around meter. Support meters, valves, and piping on brick or concrete piers.
- G. Install fire-service water meters with shutoff valves on water-meter inlet and outlet and on full-size valved bypass around meter. Support meter, valves, and piping on brick or concrete piers.
- H. Install remote registration system according to standards of utility company and of authorities having jurisdiction.

3.9 HANGER AND SUPPORT INSTALLATION

- A. Comply with requirements in Division 22 Section "Vibration and Seismic Controls for Plumbing Piping and Equipment" for seismic-restraint devices.
- B. Comply with requirements in Division 22 Section "Hangers and Supports for Plumbing Piping and Equipment" for pipe hanger and support products and installation.
 - 1. Vertical Piping: MSS Type 8 or 42, clamps.
 - 2. Individual, Straight, Horizontal Piping Runs:
 - a. 100 Feet (30 m) and Less: MSS Type 1, adjustable, steel clevis hangers.
 - b. Longer Than 100 Feet (30 m): MSS Type 43, adjustable roller hangers.
 - 3. Multiple, Straight, Horizontal Piping Runs 100 Feet (30 m) or Longer: MSS Type 44, pipe rolls. Support pipe rolls on trapeze.
 - 4. Base of Vertical Piping: MSS Type 52, spring hangers.
- C. Support vertical piping and tubing at base and at each floor.
- D. Install hangers for copper tubing with the following maximum horizontal spacing and minimum rod diameters:
 - 1. NPS 3/4 (DN 20) and Smaller: 60 inches (1500 mm) with 3/8-inch (10-mm) rod.
 - 2. NPS 1 and NPS 1-1/4 (DN 25 and DN 32): 72 inches (1800 mm) with 3/8-inch (10-mm) rod.
 - 3. NPS 1-1/2 and NPS 2 (DN 40 and DN 50): 96 inches (2400 mm) with 3/8-inch (10-mm) rod.
 - 4. NPS 2-1/2 (DN 65): 108 inches (2700 mm) with 1/2-inch (13-mm) rod.
 - 5. NPS 3 to NPS 5 (DN 80 to DN 125): 10 feet (3 m) with 1/2-inch (13-mm) rod.
 - 6. NPS 6 (DN 150): 10 feet (3 m) with 5/8-inch (16-mm) rod.
 - 7. NPS 8 (DN 200): 10 feet (3 m) with 3/4-inch (19-mm) rod.
- E. Install supports for vertical copper tubing every 10 feet (3 m).
- F. Install hangers for steel piping with the following maximum horizontal spacing and minimum rod diameters:
 - 1. NPS 1-1/4 (DN 32) and Smaller: 84 inches (2100 mm) with 3/8-inch (10-mm) rod.
 - 2. NPS 1-1/2 (DN 40): 108 inches (2700 mm) with 3/8-inch (10-mm) rod.
 - 3. NPS 2 (DN 50): 10 feet (3 m) with 3/8-inch (10-mm) rod.
 - 4. NPS 2-1/2 (DN 65): 11 feet (3.4 m) with 1/2-inch (13-mm) rod.
 - 5. NPS 3 and NPS 3-1/2 (DN 80 and DN 90): 12 feet (3.7 m) with 1/2-inch (13-mm) rod.
 - 6. NPS 4 and NPS 5 (DN 100 and DN 125): 12 feet (3.7 m) with 5/8-inch (16-mm) rod.
 - 7. NPS 6 (DN 150): 12 feet (3.7 m) with 3/4-inch (19-mm) rod.
 - 8. NPS 8 to NPS 12 (DN 200 to DN 300): 12 feet (3.7 m) with 7/8-inch (22-mm) rod.
- G. Install supports for vertical steel piping every 15 feet (4.5 m).
- H. Support piping and tubing not listed in this article according to MSS SP-69 and manufacturer's written instructions.

3.10 CONNECTIONS

- A. Drawings indicate general arrangement of piping, fittings, and specialties.
- B. Install piping adjacent to equipment and machines to allow service and maintenance.
- C. Connect domestic water piping to exterior water-service piping. Use transition fitting to join dissimilar piping materials.
- D. Connect domestic water piping to water-service piping with shutoff valve; extend and connect to the following:
 - 1. Domestic Water Booster Pumps: Cold-water suction and discharge piping.
 - 2. Water Heaters: Cold-water inlet and hot-water outlet piping in sizes indicated, but not smaller than sizes of water heater connections.
 - 3. Plumbing Fixtures: Cold- and hot-water supply piping in sizes indicated, but not smaller than required by plumbing code. Comply with requirements in Division 22 plumbing fixture Sections for connection sizes.
 - 4. Equipment: Cold- and hot-water supply piping as indicated, but not smaller than equipment connections. Provide shutoff valve and union for each connection. Use flanges instead of unions for NPS 2-1/2 (DN 65) and larger.

3.11 ESCUTCHEON INSTALLATION

- A. Install escutcheons for penetrations of walls, ceilings, and floors.
- B. Escutcheons for New Piping:
 - 1. Piping with Fitting or Sleeve Protruding from Wall: One piece, deep pattern.
 - 2. Bare Piping at Wall and Floor Penetrations in Finished Spaces: One piece, cast brass with polished chrome-plated finish .
 - 3. Bare Piping at Ceiling Penetrations in Finished Spaces: One piece, cast brass with polished chrome-plated finish.
 - 4. Bare Piping in Unfinished Service Spaces: One piece, cast brass with polished chrome-plated finish .
 - 5. Bare Piping in Equipment Rooms: One piece, cast brass .
 - 6. Bare Piping at Floor Penetrations in Equipment Rooms: One-piece floor plate.
- C. Escutcheons for Existing Piping:
 - 1. Chrome-Plated Piping: Split casting, cast brass with chrome-plated finish.
 - 2. Insulated Piping: Split plate, stamped steel with concealed hinge and spring clips.
 - 3. Bare Piping at Wall and Floor Penetrations in Finished Spaces: Split casting, cast brass with chrome-plated finish.
 - 4. Bare Piping at Ceiling Penetrations in Finished Spaces: Split casting, cast brass with chrome-plated finish.
 - 5. Bare Piping in Unfinished Service Spaces: Split casting, cast brass with polished chrome-plated finish.
 - 6. Bare Piping in Equipment Rooms: Split casting, cast brass.
 - 7. Bare Piping at Floor Penetrations in Equipment Rooms: Split-casting floor plate.

3.12 SLEEVE INSTALLATION

- A. General Requirements: Install sleeves for pipes and tubes passing through penetrations in floors, partitions, roofs, and walls.
- B. Sleeves are not required for core-drilled holes.
- C. Permanent sleeves are not required for holes formed by removable PE sleeves.
- D. Cut sleeves to length for mounting flush with both surfaces unless otherwise indicated.
- E. Install sleeves in new partitions, slabs, and walls as they are built.
- F. For interior wall penetrations, seal annular space between sleeve and pipe or pipe insulation using joint sealants appropriate for size, depth, and location of joint. Comply with requirements in Division 07 Section "Joint Sealants" for joint sealants.
- G. For exterior wall penetrations above grade, seal annular space between sleeve and pipe using joint sealants appropriate for size, depth, and location of joint. Comply with requirements in Division 07 Section "Joint Sealants" for joint sealants.
- H. For exterior wall penetrations below grade, seal annular space between sleeve and pipe using sleeve seals specified in this Section.
- I. Seal space outside of sleeves in concrete slabs and walls with grout.
- J. Install sleeves that are large enough to provide 1/4-inch (6.4-mm) annular clear space between sleeve and pipe or pipe insulation unless otherwise indicated.
- K. Install sleeve materials according to the following applications:
 - 1. Sleeves for Piping Passing through Concrete Floor Slabs: Steel pipe.
 - 2. Sleeves for Piping Passing through Concrete Floor Slabs of Mechanical Equipment Areas or Other Wet Areas: Steel pipe Stack sleeve fittings.
 - a. Extend sleeves 2 inches (50 mm) above finished floor level.
 - b. For pipes penetrating floors with membrane waterproofing, extend cast-iron sleeve fittings below floor slab as required to secure clamping ring if ring is specified. Secure flashing between clamping flanges. Install section of cast-iron soil pipe to extend sleeve to 2 inches (50 mm) above finished floor level. Comply with requirements in Division 07 Section "Sheet Metal Flashing and Trim" for flashing.
 - 3. Sleeves for Piping Passing through Gypsum-Board Partitions:
 - a. Steel pipe sleeves for pipes smaller than NPS 6 (DN 150).
 - b. Galvanized-steel sheet sleeves for pipes NPS 6 (DN 150) and larger.
 - c. Exception: Sleeves are not required for water supply tubes and waste pipes for individual plumbing fixtures if escutcheons will cover openings.
 - 4. Sleeves for Piping Passing through Concrete Roof Slabs: Steel pipe.
 - 5. Sleeves for Piping Passing through Exterior Concrete Walls:
 - a. Steel pipe sleeves for pipes smaller than NPS 6 (DN 150).
 - b. Cast-iron wall pipe sleeves for pipes NPS 6 (DN 150) and larger.
 - c. Install sleeves that are large enough to provide 1-inch (25-mm) annular clear space between sleeve and pipe or pipe insulation when sleeve seals are used.
 - d. Do not use sleeves when wall penetration systems are used.
 - 6. Sleeves for Piping Passing through Interior Concrete Walls:
 - a. Steel pipe sleeves for pipes smaller than NPS 6 (DN 150).
 - b. Galvanized-steel sheet sleeves for pipes NPS 6 (DN 150) and larger.

- L. Fire-Barrier Penetrations: Maintain indicated fire rating of walls, partitions, ceilings, and floors at pipe penetrations. Seal pipe penetrations with firestop materials. Comply with requirements in Division 07 Section "Penetration Firestopping" for firestop materials and installations.

3.13 SLEEVE SEAL INSTALLATION

- A. Install sleeve seals in sleeves in exterior concrete walls at water-service piping entries into building.
- B. Select type and number of sealing elements required for pipe material and size. Position pipe in center of sleeve. Assemble sleeve seal components and install in annular space between pipe and sleeve. Tighten bolts against pressure plates that cause sealing elements to expand and make watertight seal.

3.14 WALL PENETRATION SYSTEM INSTALLATION

- A. Install wall penetration systems in new, exterior concrete walls.
- B. Assemble wall penetration system components with sleeve pipe. Install so that end of sleeve pipe and face of housing are flush with wall. Adjust locking devices to secure sleeve pipe in housing.

3.15 IDENTIFICATION

- A. Identify system components. Comply with requirements in Division 22 Section "Identification for Plumbing Piping and Equipment" for identification materials and installation.
- B. Label pressure piping with system operating pressure.

3.16 FIELD QUALITY CONTROL

- A. Perform tests and inspections.
- B. Piping Inspections:
 - 1. Do not enclose, cover, or put piping into operation until it has been inspected and approved by authorities having jurisdiction.
 - 2. During installation, notify authorities having jurisdiction at least one day before inspection must be made. Perform tests specified below in presence of authorities having jurisdiction:
 - a. Roughing-in Inspection: Arrange for inspection of piping before concealing or closing-in after roughing-in and before setting fixtures.
 - b. Final Inspection: Arrange final inspection for authorities having jurisdiction to observe tests specified below and to ensure compliance with requirements.
 - 3. Reinspection: If authorities having jurisdiction find that piping will not pass tests or inspections, make required corrections and arrange for reinspection.
 - 4. Reports: Prepare inspection reports and have them signed by authorities having jurisdiction.

- C. Piping Tests:
 - 1. Fill domestic water piping. Check components to determine that they are not air bound and that piping is full of water.
 - 2. Test for leaks and defects in new piping and parts of existing piping that have been altered, extended, or repaired. If testing is performed in segments, submit a separate report for each test, complete with diagram of portion of piping tested.
 - 3. Leave new, altered, extended, or replaced domestic water piping uncovered and unconcealed until it has been tested and approved. Expose work that was covered or concealed before it was tested.
 - 4. Cap and subject piping to static water pressure of 50 psig (345 kPa) above operating pressure, without exceeding pressure rating of piping system materials. Isolate test source and allow to stand for four hours. Leaks and loss in test pressure constitute defects that must be repaired.
 - 5. Repair leaks and defects with new materials and retest piping or portion thereof until satisfactory results are obtained.
 - 6. Prepare reports for tests and for corrective action required.
- D. Domestic water piping will be considered defective if it does not pass tests and inspections.
- E. Prepare test and inspection reports.

3.17 ADJUSTING

- A. Perform the following adjustments before operation:
 - 1. Close drain valves, hydrants, and hose bibbs.
 - 2. Open shutoff valves to fully open position.
 - 3. Open throttling valves to proper setting.
 - 4. Adjust balancing valves in hot-water-circulation return piping to provide adequate flow.
 - a. Manually adjust ball-type balancing valves in hot-water-circulation return piping to provide flow of hot water in each branch.
 - b. Adjust calibrated balancing valves to flows indicated.
 - 5. Remove plugs used during testing of piping and for temporary sealing of piping during installation.
 - 6. Remove and clean strainer screens. Close drain valves and replace drain plugs.
 - 7. Remove filter cartridges from housings and verify that cartridges are as specified for application where used and are clean and ready for use.
 - 8. Check plumbing specialties and verify proper settings, adjustments, and operation.

3.18 CLEANING

- A. Clean and disinfect potable and non-potable domestic water piping as follows:
 - 1. Purge new piping and parts of existing piping that have been altered, extended, or repaired before using.
 - 2. Use purging and disinfecting procedures prescribed by authorities having jurisdiction; if methods are not prescribed, use procedures described in either AWWA C651 or AWWA C652 or follow procedures described below:

- a. Flush piping system with clean, potable water until dirty water does not appear at outlets.
 - b. Fill and isolate system according to either of the following:
 - 1) Fill system or part thereof with water/chlorine solution with at least 50 ppm (50 mg/L) of chlorine. Isolate with valves and allow to stand for 24 hours.
 - 2) Fill system or part thereof with water/chlorine solution with at least 200 ppm (200 mg/L) of chlorine. Isolate and allow to stand for three hours.
 - c. Flush system with clean, potable water until no chlorine is in water coming from system after the standing time.
 - d. Submit water samples in sterile bottles to authorities having jurisdiction. Repeat procedures if biological examination shows contamination.
- B. Clean non-potable domestic water piping as follows:
1. Purge new piping and parts of existing piping that have been altered, extended, or repaired before using.
 2. Use purging procedures prescribed by authorities having jurisdiction or; if methods are not prescribed, follow procedures described below:
 - a. Flush piping system with clean, potable water until dirty water does not appear at outlets.
 - b. Submit water samples in sterile bottles to authorities having jurisdiction. Repeat procedures if biological examination shows contamination.
- C. Prepare and submit reports of purging and disinfecting activities.
- D. Clean interior of domestic water piping system. Remove dirt and debris as work progresses.

3.19 PIPING SCHEDULE

- A. Transition and special fittings with pressure ratings at least equal to piping rating may be used in applications below unless otherwise indicated.
- B. Flanges and unions may be used for aboveground piping joints unless otherwise indicated.
- C. Fitting Option: Extruded-tee connections and brazed joints may be used on aboveground copper tubing.
- D. Under-building-slab, domestic water, building service piping, NPS 2 and smaller, shall be the following:
 1. Soft copper tube, ASTM B 88, Type L (ASTM B 88M, Type B); wrought-copper solder-joint fittings; and brazed joints.
- E. Under-building-slab, domestic water, building-service piping, NPS 4 to NPS 8 (DN 100 to DN 200) and larger, shall be one of the following:
 1. Mechanical-joint, ductile-iron pipe; standard-pattern mechanical-joint fittings; and mechanical joints.
 2. Push-on-joint, ductile-iron pipe; standard-pattern push-on-joint fittings; and gasketed joints.
- F. Under-building slab, combined domestic water, building-service, and fire-service-main piping, NPS 6 to NPS 12 (DN 150 to DN 300), shall be the following:

1. Mechanical-joint, ductile-iron pipe; standard pattern mechanical-joint fittings; and mechanical joints.
 2. Push-on-joint, ductile-iron pipe; standard pattern push-on-joint fittings; and gasketed joints.
- G. Under-building-slab, domestic water piping, NPS 2 (DN 50) and smaller, shall be the following:
1. Hard or soft copper tube, ASTM B 88, Type L (ASTM B 88M, Type B); wrought-copper solder-joint fittings; and brazed joints.
- H. Aboveground domestic water piping, NPS 2 (DN 50) and smaller, shall be the following:
1. Hard copper tube, ASTM B 88, Type L (ASTM B 88M, Type B); cast-copper solder-joint fittings; and soldered joints.
- I. Aboveground domestic water piping, NPS 2-1/2 to NPS 4 (DN 65 to DN 100), shall be the following:
1. Hard copper tube, ASTM B 88, Type L (ASTM B 88M, Type B); cast- or wrought- copper solder-joint fittings; and brazed joints.
 2. Hard copper tube, ASTM B 88, Type L (ASTM B 88M, Type B) grooved-joint copper-tube appurtenances; and grooved joints.
- J. Aboveground domestic water piping, NPS 5 to NPS 8 (DN 125 to DN 200), shall be the following:
1. Hard copper tube, ASTM B 88, Type L (ASTM B 88M, Type B); cast- or wrought- copper solder-joint fittings; and brazed joints.
 2. Hard copper tube, ASTM B 88, Type L (ASTM B 88M, Type B) ; grooved-joint copper-tube appurtenances; and grooved joints.
 3. Galvanized-steel pipe and nipples; galvanized, gray-iron threaded fittings; and threaded joints.
 4. Galvanized-steel pipe; grooved-joint, galvanized-steel-pipe appurtenances; and grooved joints.
- K. Aboveground, combined domestic-water-service and fire-service-main piping, NPS 6 to NPS 12 (DN 150 to (DN300), shall be the following:
1. Galvanized-steel pipe and nipples; galvanized, gray-iron threaded fittings; and threaded joints.
 2. Galvanized-steel pipe; grooved-joint, galvanized-steel-pipe appurtenances; and grooved joints.

3.20 VALVE SCHEDULE

- A. Drawings indicate valve types to be used. Where specific valve types are not indicated, the following requirements apply:
1. Shutoff Duty: Use ball or gate valves for piping NPS 2 (DN 50) and smaller. Use butterfly, ball, or gate valves with flanged ends for piping NPS 2-1/2 (DN 65) and larger.
 2. Throttling Duty: Use ball or globe valves for piping NPS 2 (DN 50) and smaller. Use butterfly or ball valves with flanged ends for piping NPS 2-1/2 (DN 65) and larger.
 3. Hot-Water Circulation Piping, Balancing Duty: Memory-stop balancing valves.
 4. Drain Duty: Hose-end drain valves.

- B. Use check valves to maintain correct direction of domestic water flow to and from equipment.
- C. Iron grooved-end valves may be used with grooved-end piping.

END OF SECTION

This page is intentionally left blank.

Section 22 11 19

DOMESTIC WATER PIPING SPECIALTIES

PART 1 - GENERAL

1.1 RELATED DOCUMENTS

- A. Drawings and general provisions of the Contract, including General and Supplementary Conditions and Division 01 Specification Sections, apply to this Section.

1.2 SUMMARY

- A. This Section includes the following domestic water piping specialties:
 - 1. Vacuum breakers.
 - 2. Backflow preventers.
 - 3. Water pressure-reducing valves.
 - 4. Balancing valves.
 - 5. Temperature-actuated water mixing valves.
 - 6. Strainers.
 - 7. Hose bibbs.
 - 8. Wall hydrants.
 - 9. Drain valves.
 - 10. Water hammer arresters.
 - 11. Air vents.
 - 12. Trap-seal primer valves.
- B. Related Sections include the following:
 - 1. Division 22 Section "Meters and Gages for Plumbing Piping" for thermometers, pressure gages, and flow meters in domestic water piping.
 - 2. Division 22 Section "Domestic Water Piping" for water meters.
 - 3. Division 22 Section "Domestic Water Filtration Equipment" for water filters in domestic water piping.
 - 4. Division 22 Section "Healthcare Plumbing Fixtures" for thermostatic mixing valves for sitz baths, thermostatic mixing-valve assemblies for hydrotherapy equipment, and outlet boxes for dialysis equipment.
 - 5. Division 22 Section "Emergency Plumbing Fixtures" for water tempering equipment.
 - 6. Division 22 Section "Drinking Fountains and Water Coolers" for water filters for water coolers.

1.3 PERFORMANCE REQUIREMENTS

- A. Minimum Working Pressure for Domestic Water Piping Specialties: 125 psig (860 kPa), unless otherwise indicated.

1.4 SUBMITTALS

- A. Product Data: For each type of product indicated.

- B. Shop Drawings: Diagram power, signal, and control wiring.
- C. Field quality-control test reports.
- D. Operation and Maintenance Data: For domestic water piping specialties to include in emergency, operation, and maintenance manuals.

1.5 QUALITY ASSURANCE

- A. Electrical Components, Devices, and Accessories: Listed and labeled as defined in NFPA 70, Article 100, by a testing agency acceptable to authorities having jurisdiction, and marked for intended use.
- B. NSF Compliance:
 - 1. Comply with NSF 14, "Plastics Piping Components and Related Materials," for plastic domestic water piping components.
 - 2. Comply with NSF 61, "Drinking Water System Components - Health Effects; Sections 1 through 9."

PART 2 - PRODUCTS

2.1 VACUUM BREAKERS

- A. Pipe-Applied, Atmospheric-Type Vacuum Breakers:
 - 1. Manufacturers: Subject to compliance with requirements, provide products by one of the following:
 - a. Ames Co.
 - b. Conbraco Industries, Inc.
 - c. FEBCO; SPX Valves & Controls.
 - d. Watts Industries, Inc.; Water Products Div.
 - e. Zurn Plumbing Products Group; Wilkins Div.
 - 2. Standard: ASSE 1001.
 - 3. Size: NPS 1/4 to NPS 3 (DN 8 to DN 80), as required to match connected piping.
 - 4. Body: Bronze.
 - 5. Inlet and Outlet Connections: Threaded.
 - 6. Finish: Chrome plated.
- B. Hose-Connection Vacuum Breakers:
 - 1. Manufacturers: Subject to compliance with requirements, provide products by one of the following:
 - a. Conbraco Industries, Inc.
 - b. MIFAB, Inc.
 - c. Watts Industries, Inc.; Water Products Div.
 - d. Woodford Manufacturing Company.
 - e. Zurn Plumbing Products Group; Wilkins Div.
 - 2. Standard: ASSE 1011.
 - 3. Body: Bronze, nonremovable, with manual drain.
 - 4. Outlet Connection: Garden-hose threaded complying with ASME B1.20.7.
 - 5. Finish: Rough bronze.
- C. Pressure Vacuum Breakers:
 - 1. Manufacturers: Subject to compliance with requirements, provide products by one of the following:

- a. Ames Co.
- b. Conbraco Industries, Inc.
- c. FEBCO; SPX Valves & Controls.
- d. Watts Industries, Inc.; Water Products Div.
- e. Zurn Plumbing Products Group; Wilkins Div.
2. Standard: ASSE 1020.
3. Operation: Continuous-pressure applications.
4. Pressure Loss: 5 psig (35 kPa) maximum, through middle 1/3 of flow range.
5. Accessories:
 - a. Valves: Ball type, on inlet and outlet.

D. Laboratory-Faucet Vacuum Breakers:

1. Available Manufacturers: Subject to compliance with requirements, manufacturers offering products that may be incorporated into the Work include, but are not limited to, the following:
2. Manufacturers: Subject to compliance with requirements, provide products by one of the following:
 - a. Conbraco Industries, Inc.
 - b. Watts Industries, Inc.; Water Products Div.
 - c. Woodford Manufacturing Company.
 - d. Zurn Plumbing Products Group; Wilkins Div.
3. Standard: ASSE 1035.
4. Size: NPS 1/4 or NPS 3/8 (DN 8 or DN 10) matching faucet size.
5. Body: Bronze.
6. End Connections: Threaded.
7. Finish: Chrome plated.

2.2 BACKFLOW PREVENTERS

A. Intermediate Atmospheric-Vent Backflow Preventers:

1. Manufacturers: Subject to compliance with requirements, provide products by one of the following:
 - a. Conbraco Industries, Inc.
 - b. FEBCO; SPX Valves & Controls.
 - c. Watts Industries, Inc.; Water Products Div.
 - d. Zurn Plumbing Products Group; Wilkins Div.
2. Standard: ASSE 1012.
3. Operation: Continuous-pressure applications.
4. Size: NPS 3/4 (DN 20).
5. Body: Bronze.
6. End Connections: Union, solder joint.
7. Finish: Rough bronze.

B. Reduced-Pressure-Principle Backflow Preventers:

1. Manufacturers: Subject to compliance with requirements, provide products by one of the following:
 - a. Ames Co.
 - b. Conbraco Industries, Inc.
 - c. FEBCO; SPX Valves & Controls.
 - d. Watts Industries, Inc.; Water Products Div.
 - e. Zurn Plumbing Products Group; Wilkins Div.
2. Standard: ASSE 1013.
3. Operation: Continuous-pressure applications.

4. Pressure Loss: 12 psig (83 kPa) maximum, through middle 1/3 of flow range.
 5. Size: As shown on the drawings.
 6. Body: Bronze for NPS 2 (DN 50) and smaller; cast iron with interior lining complying with AWWA C550 or that is FDA approved for NPS 2-1/2 (DN 65) and larger.
 7. End Connections: Threaded for NPS 2 (DN 50) and smaller; flanged for NPS 2-1/2 (DN 65) and larger.
 8. Configuration: Designed for horizontal, straight through flow.
 9. Accessories:
 - a. Valves: Ball type with threaded ends on inlet and outlet of NPS 2 (DN 50) and smaller; outside screw and yoke gate-type with flanged ends on inlet and outlet of NPS 2-1/2 (DN 65) and larger.
 - b. Air-Gap Fitting: ASME A112.1.2, matching backflow-preventer connection.
- C. Double-Check Backflow-Prevention Assemblies:
1. Manufacturers: Subject to compliance with requirements, provide products by one of the following:
 - a. Ames Co.
 - b. Conbraco Industries, Inc.
 - c. FEBCO; SPX Valves & Controls.
 - d. Watts Industries, Inc.; Water Products Div.
 - e. Zurn Plumbing Products Group; Wilkins Div.
 2. Standard: ASSE 1015.
 3. Operation: Continuous-pressure applications, unless otherwise indicated.
 4. Pressure Loss: 5 psig (35 kPa) maximum, through middle 1/3 of flow range.
 5. Body: Bronze for NPS 2 (DN 50) and smaller; cast iron with interior lining complying with AWWA C550 or that is FDA approved for NPS 2-1/2 (DN 65) and larger.
 6. End Connections: Threaded for NPS 2 (DN 50) and smaller; for NPS 2-1/2 (DN 65) and larger.
 7. Configuration: Designed for horizontal, straight through flow.
 8. Accessories:
 - a. Valves: Ball type with threaded ends on inlet and outlet of NPS 2 (DN 50) and smaller; outside screw and yoke gate-type with flanged ends on inlet and outlet of NPS 2-1/2 (DN 65) and larger.
- D. Hose-Connection Backflow Preventers:
1. Manufacturers: Subject to compliance with requirements, provide products by one of the following:
 - a. Conbraco Industries, Inc.
 - b. Watts Industries, Inc.; Water Products Div.
 - c. Woodford Manufacturing Company.
 2. Standard: ASSE 1052.
 3. Operation: Up to 10-foot head of water (30-kPa) back pressure.
 4. Inlet Size: NPS 1/2 or NPS 3/4 (DN 15 or DN 20).
 5. Outlet Size: Garden-hose thread complying with ASME B1.20.7.
 6. Capacity: At least 3-gpm (0.19-L/s) flow.
- E. Backflow-Preventer Test Kits:
1. Manufacturers: Subject to compliance with requirements, provide products by one of the following:
 - a. Conbraco Industries, Inc.
 - b. FEBCO; SPX Valves & Controls.

- c. Watts Industries, Inc.; Water Products Div.
- d. Zurn Plumbing Products Group; Wilkins Div.
2. Description: Factory calibrated, with gages, fittings, hoses, and carrying case with test-procedure instructions.

2.3 WATER PRESSURE-REDUCING VALVES

A. Water Regulators:

1. Manufacturers: Subject to compliance with requirements, provide products by one of the following:
 - a. Conbraco Industries, Inc.
 - b. Watts Industries, Inc.; Water Products Div.
 - c. Zurn Plumbing Products Group; Wilkins Div.
2. Standard: ASSE 1003.
3. Pressure Rating: Initial working pressure of 150 psig (1035 kPa).
4. Body: Bronze for NPS 2 (DN 50) and smaller; cast iron with interior lining complying with AWWA C550 or that is FDA approved for NPS 2-1/2 and NPS 3 (DN 65 and DN 80).
5. Valves for Booster Heater Water Supply: Include integral bypass.
6. End Connections: Threaded for NPS 2 (DN 50) and smaller; flanged for NPS 2-1/2 and NPS 3 (DN 65 and DN 80).

B. Water Control Valves:

1. Manufacturers: Subject to compliance with requirements, provide products by one of the following:
 - a. CLA-VAL Automatic Control Valves.
 - b. Watts Industries, Inc.; Ames Fluid Control Systems.
 - c. Watts Industries, Inc.; Watts ACV.
 - d. Zurn Plumbing Products Group; Wilkins Div.
2. Description: Pilot-operation, diaphragm-type, single-seated main water control valve.
3. Pressure Rating: Initial working pressure of 150 psig (1035 kPa) minimum with AWWA C550 or FDA-approved, interior epoxy coating. Include small pilot-control valve, restrictor device, specialty fittings, and sensor piping.
4. Main Valve Body: Cast- or ductile-iron body with AWWA C550 or FDA-approved, interior epoxy coating; or stainless-steel body.
5. End Connections: Threaded for NPS 2 (DN 50) and smaller; flanged for NPS 2-1/2 (DN 65) and larger.

2.4 BALANCING VALVES

A. Copper-Alloy Calibrated Balancing Valves:

1. Manufacturers: Subject to compliance with requirements, provide products by one of the following:
 - a. ITT Industries; Bell & Gossett Div.
 - b. NIBCO INC.
 - c. Taco, Inc.
 - d. Watts Industries, Inc.; Water Products Div.
2. Type: Ball or Y-pattern globe valve with two readout ports and memory setting indicator.
3. Body: bronze,
4. Size: Same as connected piping, but not larger than NPS 2 (DN 50).

5. Accessories: Meter hoses, fittings, valves, differential pressure meter, and carrying case.
- B. Accessories: Meter hoses, fittings, valves, differential pressure meter, and carrying case.
- C. Memory-Stop Balancing Valves:
 1. Manufacturers: Subject to compliance with requirements, provide products by one of the following:
 - a. Conbraco Industries, Inc.
 - b. Milwaukee Valve Company.
 - c. NIBCO INC.
 2. Standard: MSS SP-110 for two-piece, copper-alloy ball valves.
 3. Pressure Rating: 400-psig (2760-kPa) minimum CWP.
 4. Size: NPS 2 (DN 50) or smaller.
 5. Body: Copper alloy.
 6. Port: Standard or full port.
 7. Ball: Chrome-plated brass.
 8. Seats and Seals: Replaceable.
 9. End Connections: Solder joint or threaded.
 10. Handle: Vinyl-covered steel with memory-setting device.

2.5 TEMPERATURE-ACTUATED WATER MIXING VALVES

- A. Primary, Thermostatic, Water Mixing Valves:
 1. Manufacturers: Subject to compliance with requirements, provide products by one of the following:
 - a. Lawler Manufacturing Company, Inc.
 - b. Leonard Valve Company.
 - c. Powers; a Watts Industries Co.
 2. Standard: ASSE 1017.
 3. Pressure Rating: 125 psig (860 kPa).
 4. Type: Exposed-mounting, thermostatically controlled water mixing valve.
 5. Material: Bronze body with corrosion-resistant interior components.
 6. Connections: Threaded inlets and outlet.
 7. Accessories: Manual temperature control, check stops on hot- and cold-water supplies, and adjustable, temperature-control handle.
 8. Valve Pressure Rating: 125 psig (860 kPa) minimum, unless otherwise indicated.
 9. Tempered-Water Setting: 125 deg F (deg C).
 10. Tempered-Water Design Flow Rate: 69.44
 11. Valve Finish: Rough bronze.
 12. Piping Finish: Copper.

2.6 STRAINERS FOR DOMESTIC WATER PIPING

- A. Y-Pattern Strainers:
 1. Pressure Rating: 125 psig (860 kPa) minimum, unless otherwise indicated.
 2. Body: Bronze for NPS 2 (DN 50) and smaller; cast iron with interior lining complying with AWWA C550 or FDA-approved, epoxy coating and for NPS 2-1/2 (DN 65) and larger.
 3. End Connections: Threaded for NPS 2 (DN 50) and smaller; flanged for NPS 2-1/2 (DN 65) and larger.

4. Screen: Stainless steel with round perforations, unless otherwise indicated.
5. Perforation Size:
 - a. Strainers NPS 2 (DN 50) and Smaller: 0.033 inch (0.84 mm) .
 - b. Strainers NPS 2-1/2 to NPS 4 (DN 65 to DN 100): 0.062 inch (1.57 mm).
 - c. Strainers NPS 5 (DN 125) and Larger: 0.125 inch (3.18 mm) .
6. Drain: Factory-installed, hose-end drain valve.

2.7 HOSE BIBBS

A. Hose Bibbs:

1. Standard: ASME A112.18.1 for sediment faucets.
2. Body Material: Bronze.
3. Seat: Bronze, replaceable.
4. Supply Connections: NPS 1/2 or NPS 3/4 (DN 15 or DN 20) threaded or solder-joint inlet.
5. Outlet Connection: Garden-hose thread complying with ASME B1.20.7.
6. Pressure Rating: 125 psig (860 kPa).
7. Vacuum Breaker: Integral or field-installation, nonremovable, drainable, hose-connection vacuum breaker complying with ASSE 1011.
8. Finish for Equipment Rooms: Rough bronze, or chrome or nickel plated.
9. Finish for Service Areas: Chrome or nickel plated.
10. Finish for Finished Rooms: Chrome or nickel plated.
11. Operation for Equipment Rooms: Wheel handle or operating key.
12. Operation for Service Areas: Wheel handle Operating key.
13. Operation for Finished Rooms: Operating key.
14. Include operating key with each operating-key hose bibb.
15. Include integral wall flange with each chrome- or nickel-plated hose bibb.

2.8 WALL HYDRANTS

A. Nonfreeze Wall Hydrants:

1. Manufacturers: Subject to compliance with requirements, provide products by one of the following:
 - a. Josam Company.
 - b. MIFAB, Inc.
 - c. Smith, Jay R. Mfg. Co.; Division of Smith Industries, Inc.
 - d. Tyler Pipe; Wade Div.
 - e. Watts Drainage Products Inc.
 - f. Woodford Manufacturing Company.
 - g. Zurn Plumbing Products Group; Light Commercial Operation.
 - h. Zurn Plumbing Products Group; Specification Drainage Operation.
2. Standard: ASME A112.21.3M for concealed-outlet, self-draining wall hydrants.
3. Pressure Rating: 125 psig (860 kPa).
4. Operation: Loose key.
5. Casing and Operating Rod: Of length required to match wall thickness. Include wall clamp.
6. Inlet: NPS 3/4 or NPS 1 (DN 20 or DN 25).
7. Outlet: Concealed, with integral vacuum breaker and garden-hose thread complying with ASME B1.20.7.
8. Box: Deep, flush mounting with cover.

9. Box and Cover Finish: Chrome plated.
10. Outlet: Exposed, with integral vacuum breaker and garden-hose thread complying with ASME B1.20.7.
11. Nozzle and Wall-Plate Finish: Rough bronze.
12. Operating Keys(s): Two with each wall hydrant.

B. Vacuum Breaker Wall Hydrants:

1. Manufacturers: Subject to compliance with requirements, provide products by one of the following:
 - a. Smith, Jay. R. Mfg. Co.; Division of Smith Industries, Inc.
 - b. Watts Industries, Inc.; Water Products Div.
 - c. Woodford Manufacturing Company.
 - d. Zurn Plumbing Products Group; Light Commercial Operation.
2. Standard: ASSE 1019, Type A or Type B.
3. Type: Freeze-resistant, automatic draining with integral air-inlet valve.
4. Classification: Type B, for automatic draining with hose removed or with hose attached and nozzle closed.
5. Pressure Rating: 125 psig (860 kPa).
6. Operation: Loose key .
7. Casing and Operating Rod: Of length required to match wall thickness. Include wall clamp.
8. Inlet: NPS 1/2 or NPS 3/4 (DN 15 or DN 20).
9. Outlet: Exposed with garden-hose thread complying with ASME B1.20.7.

2.9 DRAIN VALVES

A. Ball-Valve-Type, Hose-End Drain Valves:

1. Standard: MSS SP-110 for standard-port, two-piece ball valves.
2. Pressure Rating: 400-psig (2760-kPa) minimum CWP.
3. Size: NPS 3/4 (DN 20).
4. Body: Copper alloy.
5. Ball: Chrome-plated brass.
6. Seats and Seals: Replaceable.
7. Handle: Vinyl-covered steel.
8. Inlet: Threaded or solder joint.
9. Outlet: Threaded, short nipple with garden-hose thread complying with ASME B1.20.7 and cap with brass chain.

2.10 WATER HAMMER ARRESTERS

A. Water Hammer Arresters:

1. Manufacturers: Subject to compliance with requirements, provide products by one of the following:
 - a. AMTROL, Inc.
 - b. Josam Company.
 - c. MIFAB, Inc.
 - d. PPP Inc.
 - e. Sioux Chief Manufacturing Company, Inc.
 - f. Smith, Jay R. Mfg. Co.; Division of Smith Industries, Inc.
 - g. Tyler Pipe; Wade Div.
 - h. Watts Drainage Products Inc.
 - i. Zurn Plumbing Products Group; Specification Drainage Operation.
2. Standard: ASSE 1010 or PDI-WH 201.

3. Type: Copper tube with piston.
4. Size: ASSE 1010, Sizes AA and A through F or PDI-WH 201, Sizes A through F.

2.11 AIR VENTS

- A. Bolted-Construction Automatic Air Vents:
 1. Body: Bronze.
 2. Pressure Rating: 125-psig (860-kPa) minimum pressure rating at 140 deg F (60 deg C).
 3. Float: Replaceable, corrosion-resistant metal.
 4. Mechanism and Seat: Stainless steel.
 5. Size: NPS 1/2 (DN 15) minimum inlet.
 6. Inlet and Vent Outlet End Connections: Threaded.
- B. Welded-Construction Automatic Air Vents:
 1. Body: Stainless steel.
 2. Pressure Rating: 150-psig (1035-kPa) minimum pressure rating.
 3. Float: Replaceable, corrosion-resistant metal.
 4. Mechanism and Seat: Stainless steel.
 5. Size: NPS 3/8 (DN 10) minimum inlet.
 6. Inlet and Vent Outlet End Connections: Threaded.

2.12 TRAP-SEAL PRIMER VALVES

- A. Supply-Type, Trap-Seal Primer Valves:
 1. Manufacturers: Subject to compliance with requirements, provide products by one of the following:
 - a. MIFAB, Inc.
 - b. PPP Inc.
 - c. Sioux Chief Manufacturing Company, Inc.
 - d. Smith, Jay R. Mfg. Co.; Division of Smith Industries, Inc.
 - e. Watts Industries, Inc.; Water Products Div.
 2. Standard: ASSE 1018.
 3. Pressure Rating: 125 psig (860 kPa) minimum.
 4. Body: Bronze.
 5. Inlet and Outlet Connections: NPS 1/2 (DN 15) threaded, union, or solder joint.
 6. Gravity Drain Outlet Connection: NPS 1/2 (DN 15) threaded or solder joint.
 7. Finish: Chrome plated, or rough bronze for units used with pipe or tube that is not chrome finished.
- B. Drainage-Type, Trap-Seal Primer Valves:
 1. Available Manufacturers: Subject to compliance with requirements, manufacturers offering products that may be incorporated into the Work include, but are not limited to, the following:
 2. Manufacturers: Subject to compliance with requirements, provide products by one of the following:
 - a. Smith, Jay R. Mfg. Co.; Division of Smith Industries, Inc.
 3. Standard: ASSE 1044, lavatory P-trap with NPS 3/8 (DN 10) minimum, trap makeup connection.
 4. Size: NPS 1-1/4 (DN 32) minimum.
 5. Material: Chrome-plated, cast brass.

PART 3 - EXECUTION

3.1 INSTALLATION

- A. Refer to Division 22 Section "Common Work Results for Plumbing" for piping joining materials, joint construction, and basic installation requirements.
- B. Install backflow preventers in each water supply to mechanical equipment and systems and to other equipment and water systems that may be sources of contamination. Comply with authorities having jurisdiction.
 - 1. Locate backflow preventers in same room as connected equipment or system.
 - 2. Install drain for backflow preventers with atmospheric-vent drain connection with air-gap fitting, fixed air-gap fitting, or equivalent positive pipe separation of at least two pipe diameters in drain piping and pipe to floor drain. Locate air-gap device attached to or under backflow preventer. Simple air breaks are not acceptable for this application.
 - 3. Do not install bypass piping around backflow preventers.
- C. Install water regulators with inlet and outlet shutoff valves. Install pressure gages on inlet and outlet.
- D. Install water control valves with inlet and outlet shutoff valves and bypass with globe valve. Install pressure gages on inlet and outlet.
- E. Install balancing valves in locations where they can easily be adjusted.
- F. Install temperature-actuated water mixing valves with check stops or shutoff valves on inlets and with shutoff valve on outlet.
 - 1. Install thermometers and water regulators if specified.
 - 2. Install cabinet-type units recessed in or surface mounted on wall as specified.
- G. Install Y-pattern strainers for water on supply side of each control valve, solenoid valve, and pump.
- H. Install hose stations with check stops or shutoff valves on inlets and with thermometer on outlet.
 - 1. Install shutoff valve on outlet if specified.
 - 2. Install cabinet-type units recessed in or surface mounted on wall as specified. Install 2-by-4-inch (38-by-89-mm) fire-retardant-treated-wood blocking wall reinforcement between studs. Fire-retardant-treated-wood blocking is specified in Division 06 Section "Rough Carpentry."
- I. Install nonfreeze, nondraining-type post hydrants set in concrete or pavement.
- J. Install water hammer arresters in water piping according to PDI-WH 201.
- K. Install air vents at high points of water piping. Install drain piping and discharge onto floor drain.
- L. Install supply-type, trap-seal primer valves with outlet piping pitched down toward drain trap a minimum of 1 percent, and connect to floor-drain body, trap, or inlet fitting. Adjust valve for proper flow.
- M. Install drainage-type, trap-seal primer valves as lavatory trap with outlet piping pitched down toward drain trap a minimum of 1 percent, and connect to floor-drain body, trap, or inlet fitting.

- N. Install trap-seal primer systems with outlet piping pitched down toward drain trap a minimum of 1 percent, and connect to floor-drain body, trap, or inlet fitting. Adjust system for proper flow.

3.2 CONNECTIONS

- A. Piping installation requirements are specified in other Division 22 Sections. Drawings indicate general arrangement of piping and specialties.
- B. Ground equipment according to Division 26 Section "Grounding and Bonding for Electrical Systems."
- C. Connect wiring according to Division 26 Section "Low-Voltage Electrical Power Conductors and Cables."

3.3 LABELING AND IDENTIFYING

- A. Equipment Nameplates and Signs: Install engraved plastic-laminate equipment nameplate or sign on or near each of the following:
 - 1. Pressure vacuum breakers.
 - 2. Reduced-pressure-principle backflow preventers.
 - 3. Water pressure-reducing valves.
 - 4. Calibrated balancing valves.
 - 5. Primary, thermostatic, water mixing valves.
 - 6. Manifold, thermostatic, water-mixing-valve assemblies.
 - 7. Supply-type, trap-seal primer valves.
- B. Distinguish among multiple units, inform operator of operational requirements, indicate safety and emergency precautions, and warn of hazards and improper operations, in addition to identifying unit. Nameplates and signs are specified in Division 22 Section "Identification for Plumbing Piping and Equipment."

3.4 FIELD QUALITY CONTROL

- A. Perform the following tests and prepare test reports:
 - 1. Test each pressure vacuum breaker, reduced-pressure-principle backflow preventer and double-check backflow-prevention assembly according to authorities having jurisdiction and the device's reference standard.
- B. Remove and replace malfunctioning domestic water piping specialties and retest as specified above.

3.5 ADJUSTING

- A. Set field-adjustable pressure set points of water pressure-reducing valves.
- B. Set field-adjustable flow set points of balancing valves.
- C. Set field-adjustable temperature set points of temperature-actuated water mixing valves.

END OF SECTION

This page is intentionally left blank.

Section 22 11 23

DOMESTIC WATER PUMPS

PART 1 - GENERAL

1.1 RELATED DOCUMENTS

- A. Drawings and general provisions of the Contract, including General and Supplementary Conditions and Division 01 Specification Sections, apply to this Section.
- B. Section 01 81 13 "Sustainable Design Requirements – LEED v4 for Building Design & Construction – New Construction" for sustainable design requirements and detailed sustainable design submittal requirements.
- C. Section 01 74 19 "Construction and Demolition Waste Management and Disposal" for disposal of construction, demolition and packaging waste disposal requirements.

1.2 SUMMARY

- A. This Section includes the following all-bronze and bronze-fitted centrifugal pumps for domestic cold- and hot-water circulation:
 - 1. Close-coupled, horizontally mounted, in-line centrifugal pumps.
 - 2. Close-coupled, vertically mounted, in-line centrifugal pumps.
- B. Related Sections include the following:
 - 1. Division 33 Section "Water Supply Wells" for well pumps.
- C. Sustainable Building Requirements:
 - 1. The Owner requires the Contractor to implement practices and procedures to meet the project's environmental performance goals, which include achieving LEED version 4 **Certified** level Certification. Specific project goals that may impact this area of work include: use of recycled-content materials; use of locally-manufactured materials; use of low-emitting materials; construction waste recycling; and the implementation of a construction indoor air quality management plan. The Contractor shall ensure that the requirements related to these goals, as defined in the Articles below, are implemented to the fullest extent. Substitutions, or other changes to the work proposed by the Contractor or their Subcontractors, shall not be allowed if such changes compromise the aforementioned environmental goals and LEED certification.

1.3 SUBMITTALS

- A. Product Data: For each type and size of domestic water pump specified. Include certified performance curves with operating points plotted on curves; and rated capacities of selected models, furnished specialties, and accessories.
- B. Shop Drawings: Diagram power, signal, and control wiring.
- C. Operation and Maintenance Data: For domestic water pumps to include in emergency, operation, and maintenance manuals.

1.4 QUALITY ASSURANCE

- A. Product Options: Drawings indicate size, profiles, and dimensional requirements of domestic water pumps and are based on the specific system indicated. Refer to Division 01 Section "Product Requirements."
- B. Electrical Components, Devices, and Accessories: Listed and labeled as defined in NFPA 70, Article 100, by a testing agency acceptable to authorities having jurisdiction, and marked for intended use.
- C. UL Compliance: Comply with UL 778 for motor-operated water pumps.

1.5 DELIVERY, STORAGE, AND HANDLING

- A. Retain shipping flange protective covers and protective coatings during storage.
- B. Protect bearings and couplings against damage.
- C. Comply with pump manufacturer's written rigging instructions for handling.

1.6 COORDINATION

- A. Coordinate size and location of concrete bases. Concrete, reinforcement, and formwork requirements are specified in Division 03.

PART 2 - PRODUCTS

2.1 MANUFACTURERS

- A. In other Part 2 articles where titles below introduce lists, the following requirements apply to product selection:
 - 1. Manufacturers: Subject to compliance with requirements, provide products by one of the manufacturers specified.

2.2 CLOSE-COUPLED, HORIZONTALLY MOUNTED, IN-LINE CENTRIFUGAL PUMPS

- A. Manufacturers:
 - 1. Armstrong Pumps Inc.
 - 2. Bell & Gossett Domestic Pump; ITT Industries.
 - 3. Taco, Inc.
- B. Description: Factory-assembled and -tested, overhung impeller, single-stage, close-coupled, horizontally mounted, in-line centrifugal pumps as defined in HI 1.1-1.2 and HI 1.3; and designed for installation with pump and motor shafts mounted horizontally.
 - 1. Pump Construction: All bronze.
 - a. Casing: Radially split, cast iron, with threaded companion-flange connections for pumps with NPS 2 (DN 50) pipe connections and flanged connections for pumps with NPS 2-1/2 (DN 65) pipe connections.
 - b. Impeller: ASTM B 584, cast bronze; statically and dynamically balanced, closed, and keyed to shaft.
 - c. Shaft and Shaft Sleeve: Steel shaft, with copper-alloy shaft sleeve.

- d. Seal: Mechanical, with carbon-steel rotating ring, stainless-steel spring, ceramic seat, and rubber bellows and gasket. Include water slinger on shaft between motor and seal.
- e. Bearings: Oil-lubricated; bronze-journal or ball type.
2. Shaft Coupling: Rigid type if pump is provided with coupling.
3. Motor: Single speed, with grease-lubricated ball bearings. Comply with requirements in Division 22 Section "Common Motor Requirements for Plumbing Equipment."

- C. Capacities and Characteristics:
1. As scheduled on the plans

2.3 CLOSE-COUPLED, VERTICALLY MOUNTED, IN-LINE CENTRIFUGAL PUMPS

- A. Manufacturers:
1. Armstrong Pumps Inc.
 2. Bell & Gossett Domestic Pump; ITT Industries.
 3. Grundfos Pumps Corp.
 4. Taco, Inc.
- B. Description: Factory-assembled and -tested, overhung impeller, single-stage, close-coupled, vertically mounted, in-line centrifugal pumps as defined in HI 1.1-1.2 and HI 1.3; and designed for installation with pump and motor shafts mounted vertically.
1. Pump Construction: Bronze fitted.
 - a. Casing: Radially split, cast iron, with wear rings and threaded companion-flange connections for pumps with NPS 2 (DN 50) pipe connections and flanged connections for pumps with NPS 2-1/2 (DN 65) pipe connections. Include pump manufacturer's base attachment for mounting pump on concrete base.
 - b. Impeller: ASTM B 584, cast bronze; statically and dynamically balanced, closed, and keyed to shaft.
 - c. Shaft and Shaft Sleeve: Stainless-steel shaft, with copper-alloy shaft sleeve.
 - d. Seal: Mechanical, with carbon-steel rotating ring, stainless-steel spring, ceramic seat, and rubber bellows and gasket. Include water slinger on shaft between motor and seal.
 - e. Bearings: Oil-lubricated; bronze-journal or ball type.
 2. Shaft Coupling: Rigid type if pump is provided with coupling.
 3. Motor: Single speed, with grease-lubricated ball bearings; and directly mounted to pump casing. Comply with requirements in Division 22 Section "Common Motor Requirements for Plumbing Equipment."
 - a. Lifting and Supporting Lug: Factory mounted in top of motor enclosure.
- C. Capacities and Characteristics As Shown on the Drawings:

2.4 CONTROLS

- A. Thermostats: Electric; adjustable for control of hot-water circulation pump.
1. Manufacturers:
 - a. Honeywell International, Inc.
 - b. Square D.
 2. Type: Water-immersion sensor, for installation in hot-water circulation piping.

3. Range: 65 to 200 deg F (18 to 93 deg C) .
4. Operation of Pump: On or off.
5. Transformer: Provide if required.
6. Power Requirement: 120 V, ac.
7. Settings: Start pump at 115 deg F (46 deg C) and stop pump 125 deg F (52 deg C).

2.5 FLEXIBLE CONNECTORS

- A. Manufacturers:
 1. Mercer Rubber.
 2. Metraflex, Inc.
 3. Unaflex Inc.
- B. Description: Corrugated, bronze inner tubing covered with bronze wire braid. Include copper-tube ends or bronze flanged ends, braze-welded to tubing. Include 125-psig (860-kPa) minimum working-pressure rating and ends matching pump connections.

2.6 BUILDING-AUTOMATION-SYSTEM INTERFACE

- A. Provide auxiliary contacts in pump controllers for interface to building automation system. Include the following:
 1. On-off status of each pump.
 2. Alarm status.

PART 3 - EXECUTION

3.1 EXAMINATION

- A. Examine roughing-in of domestic-water-piping system to verify actual locations of connections before pump installation.

3.2 CONCRETE BASES

- A. Install concrete bases of dimensions indicated for pumps and controllers. Refer to Division 22 Section "Common Work Results for Plumbing."
 1. Install dowel rods to connect concrete base to concrete floor. Unless otherwise indicated, install dowel rods on 18-inch (450-mm) centers around full perimeter of base.
 2. For supported equipment, install epoxy-coated anchor bolts that extend through concrete base and anchor into structural concrete floor.
 3. Place and secure anchorage devices. Use setting drawings, templates, diagrams, instructions, and directions furnished with items to be embedded.
 4. Install anchor bolts to elevations required for proper attachment to supported equipment.
- B. Cast-in-place concrete materials and placement requirements are specified in Division 03.

3.3 PUMP INSTALLATION

- A. Comply with HI 1.4.
- B. Install pumps with access for periodic maintenance including removal of motors, impellers, couplings, and accessories.
- C. Independently support pumps and piping so weight of piping is not supported by pumps and weight of pumps is not supported by piping.
- D. Install close-coupled, horizontally mounted, in-line centrifugal pumps with motor and pump shafts horizontal.
- E. Install continuous-thread hanger rods and spring hangers with vertical-limit stop of sufficient size to support pump weight. Vibration isolation devices are specified in Division 22 Section "Vibration and Seismic Controls for Plumbing Piping and Equipment." Fabricate brackets or supports as required. Hanger and support materials are specified in Division 22 Section "Hangers and Supports for Plumbing Piping and Equipment."
- F. Suspend vertically mounted, in-line centrifugal pumps independent of piping. Install pumps with motor and pump shafts vertical. Use continuous-thread hanger rods and spring hangers with vertical-limit stop of sufficient size to support pump weight. Vibration isolation devices are specified in Division 21 Section "Vibration and Seismic Controls for Fire-Suppression Piping and Equipment." Hanger and support materials are specified in Division 22 Section "Hangers and Supports for Plumbing Piping and Equipment."
- G. Install vertical in-line pumps on concrete bases. Install pumps with motor and pump shafts vertical.

3.4 CONTROL INSTALLATION

- A. Install immersion-type thermostats in hot-water return piping.

3.5 CONNECTIONS

- A. Piping installation requirements are specified in other Division 22 Sections. Drawings indicate general arrangement of piping, fittings, and specialties.
- B. Install piping adjacent to pumps to allow service and maintenance.
- C. Connect domestic water piping to pumps. Install suction and discharge piping equal to or greater than size of pump nozzles. Refer to Division 22 Section "Domestic Water Piping."
 - 1. Install flexible connectors adjacent to pumps in suction and discharge piping of the following pumps:
 - a. Close-coupled, horizontally mounted, in-line centrifugal pumps.
 - b. Close-coupled, vertically mounted, in-line centrifugal pumps.
 - 2. Install shutoff valve and strainer on suction side of pumps, and check valve and throttling valve on discharge side of pumps. Install valves same size as connected piping. Refer to Division 22 Section "General-Duty Valves for Plumbing Piping" for general-duty valves for domestic water piping and Division 22 Section "Domestic Water Piping Specialties" for strainers.

3. Install pressure gages at suction and discharge of pumps. Install at integral pressure-gage tappings where provided or install pressure-gage connectors in suction and discharge piping around pumps. Refer to Division 22 Section "Meters and Gages for Plumbing Piping" for pressure gages and gage connectors.
- D. Ground equipment according to Division 26 Section "Grounding and Bonding for Electrical Systems."
- E. Connect wiring according to Division 26 Section "Low-Voltage Electrical Power Conductors and Cables."
- F. Connect thermostats and timers to pumps that they control.
- G. Interlock pump with water heater burner and time delay relay.

3.6 STARTUP SERVICE

- A. Engage a factory-authorized service representative to perform startup service.
 1. Complete installation and startup checks according to manufacturer's written instructions.
 2. Check piping connections for tightness.
 3. Clean strainers on suction piping.
 4. Set thermostats and timers for automatic starting and stopping operation of pumps.
 5. Perform the following startup checks for each pump before starting:
 - a. Verify bearing lubrication.
 - b. Verify that pump is free to rotate by hand and that pump for handling hot liquid is free to rotate with pump hot and cold. If pump is bound or drags, do not operate until cause of trouble is determined and corrected.
 - c. Verify that pump is rotating in the correct direction.
 6. Prime pump by opening suction valves and closing drains, and prepare pump for operation.
 7. Start motor.
 8. Open discharge valve slowly.
 9. Adjust temperature settings on thermostats.
 10. Adjust timer settings.

3.7 DEMONSTRATION

- A. Engage a factory-authorized service representative to train Owner's maintenance personnel to adjust, operate, and maintain controls and pumps. Refer to Division 01 Section "Demonstration and Training."

END OF SECTION

SECTION 22 13 16

SANITARY WASTE, VENT PIPING AND STORM DRAINAGE

PART 1 - GENERAL

1.1 RELATED DOCUMENTS

- A. Drawings and general provisions of the Contract, including General and Supplementary Conditions and Division 01 Specification Sections, apply to this Section.
- B. Section 01 81 13 "Sustainable Design Requirements – LEED v4 for Building Design & Construction – New Construction" for sustainable design requirements and detailed sustainable design submittal requirements.
- C. Section 01 74 19 "Construction and Demolition Waste Management and Disposal" for disposal of construction, demolition and packaging waste disposal requirements.

1.2 SUMMARY

- A. This Section includes the following for soil, waste, and vent piping inside the building:
 - 1. Pipe, tube, and fittings.
 - 2. Special pipe fittings.
 - 3. Encasement for underground metal piping.
- B. Related Sections include the following:
 - 1. Division 22 Section "Chemical Waste Systems for Laboratory and Healthcare Facilities" for chemical-waste and vent piping systems.
- C. Sustainable Building Requirements:
 - 1. The Owner requires the Contractor to implement practices and procedures to meet the project's environmental performance goals, which include achieving LEED version 4 **Certified** level Certification. Specific project goals that may impact this area of work include: use of recycled-content materials; use of locally-manufactured materials; use of low-emitting materials; construction waste recycling; and the implementation of a construction indoor air quality management plan. The Contractor shall ensure that the requirements related to these goals, as defined in the Articles below, are implemented to the fullest extent. Substitutions, or other changes to the work proposed by the Contractor or their Subcontractors, shall not be allowed if such changes compromise the aforementioned environmental goals and LEED certification.

1.3 DEFINITIONS

- A. ABS: Acrylonitrile-butadiene-styrene plastic.
- B. EPDM: Ethylene-propylene-diene terpolymer rubber.
- C. LLDPE: Linear, low-density polyethylene plastic.

- D. NBR: Acrylonitrile-butadiene rubber.
- E. PE: Polyethylene plastic.
- F. PVC: Polyvinyl chloride plastic.
- G. TPE: Thermoplastic elastomer.

1.4 PERFORMANCE REQUIREMENTS

- A. Components and installation shall be capable of withstanding the following minimum working pressure, unless otherwise indicated:
 - 1. Soil, Waste, and Vent Piping: 10-foot head of water (30 kPa).
 - 2. Sanitary Sewer, Force-Main Piping: 50 psig (345 kPa) .
- B. Seismic Performance: Soil, waste, and vent piping and support and installation shall be capable of withstanding the effects of seismic events determined according to ASCE 7, "Minimum Design Loads for Buildings and Other Structures."

1.5 SUBMITTALS

- A. Product Data: For pipe, tube, fittings, and couplings.
- B. Shop Drawings:
 - 1. Design Calculations: Signed and sealed by a qualified professional engineer for selecting seismic restraints.
 - 2. Sovent Drainage System: Include plans, elevations, sections, and details.
- C. Field quality-control inspection and test reports.

1.6 QUALITY ASSURANCE

- A. Piping materials shall bear label, stamp, or other markings of specified testing agency.
- B. Comply with NSF 14, "Plastics Piping Systems Components and Related Materials," for plastic piping components. Include marking with "NSF-dwv" for plastic drain, waste, and vent piping; "NSF-drain" for plastic drain piping; "NSF-tubular" for plastic continuous waste piping; and "NSF-sewer" for plastic sewer piping.

PART 2 - PRODUCTS

2.1 MANUFACTURERS

- A. In other Part 2 articles where titles below introduce lists, the following requirements apply to product selection:
 - 1. Manufacturers: Subject to compliance with requirements, provide products by one of the manufacturers specified.

2.2 PIPING MATERIALS

- A. Refer to Part 3 "Piping Applications" Article for applications of pipe, tube, fitting, and joining materials.

2.3 HUB-AND-SPIGOT, CAST-IRON SOIL PIPE AND FITTINGS

- A. Pipe and Fittings: ASTM A 74, Service and Extra-Heavy class(es).
- B. Gaskets: ASTM C 564, rubber.
- C. Calking Materials: ASTM B 29, pure lead and oakum or hemp fiber.

2.4 HUBLESS CAST-IRON SOIL PIPE AND FITTINGS

- A. Pipe and Fittings: ASTM A 888 or CISPI 301.
- B. Sovent Stack Fittings: ASME B16.45 or ASSE 1043, hubless, cast-iron aerator and deaerator drainage fittings.
- C. Shielded Couplings: ASTM C 1277 assembly of metal shield or housing, corrosion-resistant fasteners, and rubber sleeve with integral, center pipe stop.
 - 1. Heavy-Duty, Shielded, Stainless-Steel Couplings: With stainless-steel shield, stainless-steel bands and tightening devices, and ASTM C 564, rubber sleeve.
 - a. Manufacturers:
 - 1) ANACO.
 - 2) Clamp-All Corp.
 - 3) Tyler Pipe; Soil Pipe Div.

2.5 STEEL PIPE AND FITTINGS

- A. Steel Pipe: ASTM A 53/A 53M, Type E or S, Grade A or B, Standard Weight or Schedule 40, galvanized. Include ends matching joining method.
- B. Drainage Fittings: ASME B16.12, galvanized, threaded, cast-iron drainage pattern.
- C. Pressure Fittings:
 - 1. Steel Pipe Nipples: ASTM A 733, made of ASTM A 53/A 53M or ASTM A 106, Schedule 40, galvanized, seamless steel pipe. Include ends matching joining method.
 - 2. Malleable-Iron Unions: ASME B16.39; Class 150; hexagonal-stock body with ball-and-socket, metal-to-metal, bronze seating surface; and female threaded ends.
 - 3. Gray-Iron, Threaded Fittings: ASME B16.4, Class 125, galvanized, standard pattern.
 - 4. Cast-Iron Flanges: ASME B16.1, Class 125.
 - 5. Cast-Iron, Flanged Fittings: ASME B16.1, Class 125, galvanized.
- D. Grooved-Joint Systems:
 - 1. Manufacturers:
 - a. Anvil International.
 - b. Star Pipe Products; Star Fittings Div.
 - c. Victaulic Company.
 - d. Ward Manufacturing, Inc.
 - 2. Grooved-End, Steel-Piping Fittings: ASTM A 47/A 47M, galvanized, malleable-iron casting; ASTM A 106, galvanized-steel pipe; or ASTM A 536, galvanized, ductile-iron casting; with dimensions matching steel pipe.
 - 3. Grooved-End, Steel-Piping Couplings: AWWA C606, for steel-pipe dimensions. Include ferrous housing sections, gasket suitable for water, and bolts and nuts.

2.6 COPPER TUBE AND FITTINGS

- A. Copper DWV Tube: ASTM B 306, drainage tube, drawn temper.
 - 1. Copper Drainage Fittings: ASME B16.23, cast copper or ASME B16.29, wrought copper, solder-joint fittings.
- B. Hard Copper Tube: ASTM B 88, Types L and M (ASTM B 88M, Types B and C), water tube, drawn temper.
 - 1. Copper Pressure Fittings: ASME B16.18, cast-copper-alloy or ASME B16.22, wrought-copper, solder-joint fittings. Furnish wrought-copper fittings if indicated.
 - 2. Copper Flanges: ASME B16.24, Class 150, cast copper with solder-joint end.
 - 3. Copper Unions: MSS SP-123, copper-alloy, hexagonal-stock body with ball-and-socket, metal-to-metal seating surfaces, and solder-joint or threaded ends.

2.7 SPECIAL PIPE FITTINGS

- A. Flexible, Nonpressure Pipe Couplings: Comply with ASTM C 1173, elastomeric, sleeve-type, reducing or transition pattern. Include shear ring, ends of same sizes as piping to be joined, and corrosion-resistant-metal tension band and tightening mechanism on each end.
 - 1. Manufacturers:
 - a. Fernco, Inc.
 - b. Mission Rubber Co.
 - c. Plastic Oddities, Inc.
 - 2. Sleeve Materials:
 - a. For Cast-Iron Soil Pipes: ASTM C 564, rubber.
 - b. For Plastic Pipes: ASTM F 477, elastomeric seal or ASTM D 5926, PVC.
 - c. For Dissimilar Pipes: ASTM D 5926, PVC or other material compatible with pipe materials being joined.
- B. Shielded Nonpressure Pipe Couplings: ASTM C 1460, elastomeric or rubber sleeve with full-length, corrosion-resistant outer shield and corrosion-resistant-metal tension band and tightening mechanism on each end.
 - 1. Manufacturers:
 - a. Mission Rubber Co.
- C. Rigid, Unshielded, Nonpressure Pipe Couplings: ASTM C 1461, sleeve-type reducing- or transition-type mechanical coupling molded from ASTM C 1440, TPE material with corrosion-resistant-metal tension band and tightening mechanism on each end.
 - 1. Manufacturers:
 - a. ANACO.
- D. Pressure Pipe Couplings: AWWA C219 metal, sleeve-type same size as, with pressure rating at least equal to, and ends compatible with, pipes to be joined.
 - 1. Manufacturers:
 - a. Dresser, Inc.; DMD Div.
 - b. EBAA Iron Sales, Inc.
 - c. Romac Industries, Inc.
 - 2. Center-Sleeve Material: Ductile iron.
 - 3. Gasket Material: Natural or synthetic rubber.
 - 4. Metal Component Finish: Corrosion-resistant coating or material.

- E. Flexible Ball Joints: Ductile-iron fitting with combination of flanged and mechanical-joint ends complying with AWWA C110 or AWWA C153. Include gasketed ball-joint section and ductile-iron gland, rubber gasket, and steel bolts.
 - 1. Manufacturers:
 - a. EBAA Iron Sales, Inc.
- F. Expansion Joints: Two or three-piece, ductile-iron assembly consisting of telescoping sleeve(s) with gaskets and restrained-type, ductile-iron, bell-and-spigot end sections complying with AWWA C110 or AWWA C153. Select and assemble components for expansion indicated. Include AWWA C111, ductile-iron glands, rubber gaskets, and steel bolts.
 - 1. Manufacturers:
 - a. EBAA Iron Sales, Inc.
 - b. Romac Industries, Inc.

2.8 ENCASEMENT FOR UNDERGROUND METAL PIPING

- A. Description: ASTM A 674 or AWWA C105, high-density, crosslaminated PE film of **0.004-inch (0.10-mm)** minimum thickness.
- B. Form: tube.
- C. Color: Black.

PART 3 - EXECUTION

3.1 EXCAVATION

- A. Refer to Division 31 Section "Earth Moving" for excavating, trenching, and backfilling.

3.2 PIPING APPLICATIONS

- A. Flanges and unions may be used on aboveground pressure piping, unless otherwise indicated.
- B. Aboveground, soil and waste piping **NPS 4 (DN 100)** and smaller shall be the following:
 - 1. Service class, cast-iron soil pipe and fittings; gaskets; and gasketed joints.
 - 2. Hubless cast-iron soil pipe and fittings; heavy-duty shielded, stainless-steel couplings; and hubless-coupling joints.
 - 3. Copper DWV tube, copper drainage fittings, and soldered joints.
 - 4. Dissimilar Pipe-Material Couplings: Flexible nonpressure pipe couplings for joining dissimilar pipe materials with small difference in OD.
- C. Aboveground, soil and waste piping **NPS 5 (DN 125)** and larger shall be the following:
 - 1. Service class, cast-iron soil pipe and fittings; gaskets; and gasketed joints.
 - 2. Hubless cast-iron soil pipe and fittings; shielded, stainless-steel couplings; and hubless-coupling joints.
 - 3. Dissimilar Pipe-Material Couplings: Flexible, nonpressure pipe couplings for joining dissimilar pipe materials with small difference in OD.
- D. Aboveground, vent piping **NPS 4 (DN 100)** and smaller shall be the following:

1. Service class, cast-iron soil pipe and fittings; gaskets; and gasketed joints.
 2. Hubless cast-iron soil pipe and fittings; heavy-duty shielded, stainless-steel couplings; and hubless-coupling joints.
 3. Stainless-steel pipe and fittings gaskets, and gasketed joints.
 4. Copper DWV tube, copper drainage fittings, and soldered joints.
 - a. Option for Vent Piping, **NPS 2-1/2 and NPS 3-1/2 (DN 65 and DN 90)**: Hard copper tube, **Type M (Type C)**; copper pressure fittings; and soldered joints.
 5. Dissimilar Pipe-Material Couplings: Flexible, nonpressure pipe couplings for joining dissimilar pipe materials with small difference in OD.
- E. Aboveground, vent piping **NPS 5 (DN 125)** and larger shall be the following:
1. Service class, cast-iron soil pipe and fittings; gaskets; and gasketed joints.
 2. Hubless cast-iron soil pipe and fittings; heavy-duty shielded, stainless-steel couplings; and hubless-coupling joints.
 3. Dissimilar Pipe-Material Couplings: Flexible, nonpressure pipe couplings for joining dissimilar pipe materials with small difference in OD.
- F. Underground, soil, waste, and vent piping **NPS 4 (DN 100)** and smaller shall be the following:
1. Extra-Heavy Service class, cast-iron soil piping; gaskets; and gasketed joints.
 2. Stainless-steel pipe and fittings, gaskets, and gasketed joints.
 3. Dissimilar Pipe-Material Couplings: Flexible, nonpressure pipe couplings for joining dissimilar pipe materials with small difference in OD.
- G. Underground, soil and waste piping **NPS 5 (DN 125)** and larger shall be the following:
1. Extra-Heavy Service class, cast-iron soil piping; gaskets; and gasketed joints.
 2. Dissimilar Pipe-Material Couplings: Flexible, nonpressure pipe couplings for joining dissimilar pipe materials with small difference in OD.

3.3 PIPING INSTALLATION

- A. Sanitary sewer piping outside the building is specified in Division 22 Section "Facility Sanitary Sewers."
- B. Basic piping installation requirements are specified in Division 22 Section "Common Work Results for Plumbing."
- C. Install seismic restraints on piping. Seismic-restraint devices are specified in Division 22 Section "Vibration and Seismic Controls for Plumbing Piping and Equipment."
- D. Install cleanouts at grade and extend to where building sanitary drains connect to building sanitary sewers.
- E. Install cleanout fitting with closure plug inside the building in sanitary force-main piping.
- F. Install underground, ductile-iron, force-main piping according to AWWA C600. Install buried piping inside the building between wall and floor penetrations and connection to sanitary sewer piping outside the building with restrained joints. Anchor pipe to wall or floor. Install thrust-block supports at vertical and horizontal offsets.
 1. Install encasement on piping according to ASTM A 674 or AWWA C105.
- G. Install underground, ductile-iron, special pipe fittings according to AWWA C600.

1. Install encasement on piping according to ASTM A 674 or AWWA C105.
 - H. Install cast-iron sleeve with water stop and mechanical sleeve seal at each service pipe penetration through foundation wall. Select number of interlocking rubber links required to make installation watertight. Sleeves and mechanical sleeve seals are specified in Division 22 Section "Common Work Results for Plumbing."
 - I. Install wall-penetration fitting at each service pipe penetration through foundation wall. Make installation watertight.
 - J. Install cast-iron soil piping according to CISPI's "Cast Iron Soil Pipe and Fittings Handbook," Chapter IV, "Installation of Cast Iron Soil Pipe and Fittings."
 1. Install encasement on underground piping according to ASTM A 674 or AWWA C105.
 - K. Make changes in direction for soil and waste drainage and vent piping using appropriate branches, bends, and long-sweep bends. Sanitary tees and short-sweep 1/4 bends may be used on vertical stacks if change in direction of flow is from horizontal to vertical. Use long-turn, double Y-branch and 1/8-bend fittings if 2 fixtures are installed back to back or side by side with common drain pipe. Straight tees, elbows, and crosses may be used on vent lines. Do not change direction of flow more than 90 degrees. Use proper size of standard increasers and reducers if pipes of different sizes are connected. Reducing size of drainage piping in direction of flow is prohibited.
 - L. Lay buried building drainage piping beginning at low point of each system. Install true to grades and alignment indicated, with unbroken continuity of invert. Place hub ends of piping upstream. Install required gaskets according to manufacturer's written instructions for use of lubricants, cements, and other installation requirements. Maintain swab in piping and pull past each joint as completed.
 - M. Install soil and waste drainage and vent piping at the following minimum slopes, unless otherwise indicated:
 1. Building Sanitary Drain: 2 percent downward in direction of flow for piping **NPS 3 (DN 80)** and smaller; 1 percent downward in direction of flow for piping **NPS 4 (DN 100)** and larger.
 2. Horizontal Sanitary Drainage Piping: 2 percent downward in direction of flow.
 3. Vent Piping: 1 percent down toward vertical fixture vent or toward vent stack.
 - N. Sleeves are not required for cast-iron soil piping passing through concrete slabs-on-grade if slab is without membrane waterproofing.
 - O. Do not enclose, cover, or put piping into operation until it is inspected and approved by authorities having jurisdiction.
- 3.4 JOINT CONSTRUCTION
- A. Basic piping joint construction requirements are specified in Division 22 Section "Common Work Results for Plumbing."
 - B. Join hub-and-spigot, cast-iron soil piping with gasket joints according to CISPI's "Cast Iron Soil Pipe and Fittings Handbook" for compression joints.
 - C. Join hubless cast-iron soil piping according to CISPI 310 and CISPI's "Cast Iron Soil Pipe and Fittings Handbook" for hubless-coupling joints.
 - D. Soldered Joints: Use ASTM B 813, water-flushable, lead-free flux; ASTM B 32, lead-free-alloy solder; and ASTM B 828 procedure, unless otherwise indicated.

- E. Grooved Joints: Assemble joint with keyed coupling, gasket, lubricant, and bolts according to coupling and fitting manufacturer's written instructions.

3.5 VALVE INSTALLATION

- A. General valve installation requirements are specified in Division 22 Section "General-Duty Valves for Plumbing Piping."
- B. Shutoff Valves: Install shutoff valve on each sewage pump discharge.
 - 1. Install gate or full-port ball valve for piping **NPS 2 (DN 50)** and smaller.
 - 2. Install gate valve for piping **NPS 2-1/2 (DN 65)** and larger.
- C. Check Valves: Install swing check valve, between pump and shutoff valve, on each sewage pump discharge.
- D. Backwater Valves: Install backwater valves in piping subject to sewage backflow.
 - 1. Horizontal Piping: Horizontal backwater valves. Use normally closed type, unless otherwise indicated.
 - 2. Floor Drains: Drain outlet backwater valves, unless drain has integral backwater valve.
 - 3. Install backwater valves in accessible locations.
 - 4. Backwater valve are specified in Division 22 Section "Sanitary Waste Piping Specialities."

3.6 HANGER AND SUPPORT INSTALLATION

- A. Seismic-restraint devices are specified in Division 22 Section "Vibration and Seismic Controls for Plumbing Piping and Equipment."
- B. Pipe hangers and supports are specified in Division 22 Section "Hangers and Supports for Plumbing Piping and Equipment." Install the following:
 - 1. Vertical Piping: MSS Type 8 or Type 42, clamps.
 - 2. Install individual, straight, horizontal piping runs according to the following:
 - a. **100 Feet (30 m)** and Less: MSS Type 1, adjustable, steel clevis hangers.
 - b. Longer Than **100 Feet (30 m)**: MSS Type 43, adjustable roller hangers.
 - c. Longer Than **100 Feet (30 m)**, if Indicated: MSS Type 49, spring cushion rolls.
 - 3. Multiple, Straight, Horizontal Piping Runs **100 Feet (30 m)** or Longer: MSS Type 44, pipe rolls. Support pipe rolls on trapeze.
 - 4. Base of Vertical Piping: MSS Type 52, spring hangers.
- C. Install supports according to Division 22 Section "Hangers and Supports for Plumbing Piping and Equipment."
- D. Support vertical piping and tubing at base and at each floor.
- E. Rod diameter may be reduced 1 size for double-rod hangers, with **3/8-inch (10-mm)** minimum rods.
- F. Install hangers for cast-iron soil piping with the following maximum horizontal spacing and minimum rod diameters:
 - 1. **NPS 1-1/2 and NPS 2 (DN 40 and DN 50)**: **60 inches (1500 mm)** with **3/8-inch (10-mm)** rod.
 - 2. **NPS 3 (DN 80)**: **60 inches (1500 mm)** with **1/2-inch (13-mm)** rod.
 - 3. **NPS 4 and NPS 5 (DN 100 and DN 125)**: **60 inches (1500 mm)** with **5/8-inch (16-mm)** rod.

4. NPS 6 (DN 150): 60 inches (1500 mm) with 3/4-inch (19-mm) rod.
 5. NPS 8 to NPS 12 (DN 200 to DN 300): 60 inches (1500 mm) with 7/8-inch (22-mm) rod.
- G. Install supports for vertical cast-iron soil piping every 15 feet (4.5 m).
- H. Install hangers for steel piping with the following maximum horizontal spacing and minimum rod diameters:
1. NPS 1-1/4 (DN 32): 84 inches (2100 mm) with 3/8-inch (10-mm) rod.
 2. NPS 1-1/2 (DN 40): 108 inches (2700 mm) with 3/8-inch (10-mm) rod.
 3. NPS 2 (DN 50): 10 feet (3 m) with 3/8-inch (10-mm) rod.
 4. NPS 2-1/2 (DN 65): 11 feet (3.4 m) with 1/2-inch (13-mm) rod.
 5. NPS 3 (DN 80): 12 feet (3.7 m) with 1/2-inch (13-mm) rod.
 6. NPS 4 and NPS 5 (DN 100 and DN 125): 12 feet (3.7 m) with 5/8-inch (16-mm) rod.
 7. NPS 6 (DN 150): 12 feet (3.7 m) with 3/4-inch (19-mm) rod.
 8. NPS 8 to NPS 12 (DN 200 to DN 300): 12 feet (3.7 m) with 7/8-inch (22-mm) rod.
- I. Install supports for vertical steel piping every 15 feet (4.5 m).
- J. Install hangers for copper tubing with the following maximum horizontal spacing and minimum rod diameters:
1. NPS 1-1/4 (DN 32): 72 inches (1800 mm) with 3/8-inch (10-mm) rod.
 2. NPS 1-1/2 and NPS 2 (DN 40 and DN 50): 96 inches (2400 mm) with 3/8-inch (10-mm) rod.
 3. NPS 2-1/2 (DN 65): 108 inches (2700 mm) with 1/2-inch (13-mm) rod.
 4. NPS 3 to NPS 5 (DN 80 to DN 125): 10 feet (3 m) with 1/2-inch (13-mm) rod.
 5. NPS 6 (DN 150): 10 feet (3 m) with 5/8-inch (16-mm) rod.
 6. NPS 8 (DN 200): 10 feet (3 m) with 3/4-inch (19-mm) rod.
- K. Install supports for vertical copper tubing every 10 feet (3 m).
- 3.7 CONNECTIONS
- A. Drawings indicate general arrangement of piping, fittings, and specialties.
- B. Connect soil and waste piping to exterior sanitary sewerage piping. Use transition fitting to join dissimilar piping materials.
- C. Connect drainage and vent piping to the following:
1. Plumbing Fixtures: Connect drainage piping in sizes indicated, but not smaller than required by plumbing code.
 2. Plumbing Fixtures and Equipment: Connect atmospheric vent piping in sizes indicated, but not smaller than required by authorities having jurisdiction.
 3. Plumbing Specialties: Connect drainage and vent piping in sizes indicated, but not smaller than required by plumbing code.
 4. Equipment: Connect drainage piping as indicated. Provide shutoff valve, if indicated, and union for each connection. Use flanges instead of unions for connections NPS 2-1/2 (DN 65) and larger.
- D. Connect force-main piping to the following:
1. Sanitary Sewer: To exterior force main or sanitary manhole.
 2. Sewage Pumps: To sewage pump discharge.

3.8 FIELD QUALITY CONTROL

- A. During installation, notify authorities having jurisdiction at least 24 hours before inspection must be made. Perform tests specified below in presence of authorities having jurisdiction.
 - 1. Roughing-in Inspection: Arrange for inspection of piping before concealing or closing-in after roughing-in and before setting fixtures.
 - 2. Final Inspection: Arrange for final inspection by authorities having jurisdiction to observe tests specified below and to ensure compliance with requirements.
- B. Reinspection: If authorities having jurisdiction find that piping will not pass test or inspection, make required corrections and arrange for reinspection.
- C. Reports: Prepare inspection reports and have them signed by authorities having jurisdiction.
- D. Test sanitary drainage and vent piping according to procedures of authorities having jurisdiction or, in absence of published procedures, as follows:
 - 1. Test for leaks and defects in new piping and parts of existing piping that have been altered, extended, or repaired. If testing is performed in segments, submit separate report for each test, complete with diagram of portion of piping tested.
 - 2. Leave uncovered and unconcealed new, altered, extended, or replaced drainage and vent piping until it has been tested and approved. Expose work that was covered or concealed before it was tested.
 - 3. Roughing-in Plumbing Test Procedure: Test drainage and vent piping, except outside leaders, on completion of roughing-in. Close openings in piping system and fill with water to point of overflow, but not less than **10-foot head of water (30 kPa)**. From 15 minutes before inspection starts to completion of inspection, water level must not drop. Inspect joints for leaks.
 - 4. Finished Plumbing Test Procedure: After plumbing fixtures have been set and traps filled with water, test connections and prove they are gastight and watertight. Plug vent-stack openings on roof and building drains where they leave building. Introduce air into piping system equal to pressure of **1-inch wg (250 Pa)**. Use U-tube or manometer inserted in trap of water closet to measure this pressure. Air pressure must remain constant without introducing additional air throughout period of inspection. Inspect plumbing fixture connections for gas and water leaks.
 - 5. Repair leaks and defects with new materials and retest piping, or portion thereof, until satisfactory results are obtained.
 - 6. Prepare reports for tests and required corrective action.

3.9 CLEANING

- A. Clean interior of piping. Remove dirt and debris as work progresses.
- B. Protect drains during remainder of construction period to avoid clogging with dirt and debris and to prevent damage from traffic and construction work.
- C. Place plugs in ends of uncompleted piping at end of day and when work stops.

END OF SECTION

SECTION 22 13 19

SANITARY WASTE PIPING SPECIALTIES

PART 1 - GENERAL

1.1 RELATED DOCUMENTS

- A. Drawings and general provisions of the Contract, including General and Supplementary Conditions and Division 01 Specification Sections, apply to this Section.
- B. Section 01 81 13 "Sustainable Design Requirements – LEED v4 for Building Design & Construction – New Construction" for sustainable design requirements and detailed sustainable design submittal requirements.
- C. Section 01 74 19 "Construction and Demolition Waste Management and Disposal" for disposal of construction, demolition and packaging waste disposal requirements.

1.2 SUMMARY

- A. This Section includes the following sanitary drainage piping specialties:
 - 1. Cleanouts.
 - 2. Floor drains.
 - 3. Trench drains.
 - 4. Air-admittance valves.
 - 5. Roof flashing assemblies.
 - 6. Through-penetration firestop assemblies.
 - 7. Miscellaneous sanitary drainage piping specialties.
 - 8. Flashing materials.
 - 9. Solids interceptors.
- B. Related Sections include the following:
 - 1. Division 22 Section "Storm Drainage Piping Specialties" for trench drains for storm water, channel drainage systems for storm water, roof drains, and catch basins.
 - 2. Division 22 Section "Plumbing Fixtures" for hair interceptors.
- C. Sustainable Building Requirements:
 - 1. The Owner requires the Contractor to implement practices and procedures to meet the project's environmental performance goals, which include achieving LEED version 4 **Certified** level Certification. Specific project goals that may impact this area of work include: use of recycled-content materials; use of locally-manufactured materials; use of low-emitting materials; construction waste recycling; and the implementation of a construction indoor air quality management plan. The Contractor shall ensure that the requirements related to these goals, as defined in the Articles below, are implemented to the fullest extent. Substitutions, or other changes to the work proposed by the Contractor or their Subcontractors, shall not be allowed if such changes compromise the aforementioned environmental goals and LEED certification.

1.3 DEFINITIONS

- A. ABS: Acrylonitrile-butadiene-styrene plastic.
- B. FOG: Fats, oils, and greases.
- C. FRP: Fiberglass-reinforced plastic.
- D. HDPE: High-density polyethylene plastic.
- E. PE: Polyethylene plastic.
- F. PP: Polypropylene plastic.
- G. PVC: Polyvinyl chloride plastic.

1.4 SUBMITTALS

- A. Product Data: For each type of product indicated. Include rated capacities, operating characteristics, and accessories for the following:
 - 1. Solids Interceptions
- B. Shop Drawings: Show fabrication and installation details for frost-resistant vent terminals.
 - 1. Wiring Diagrams: Power, signal, and control wiring.
- C. Field quality-control test reports.
- D. Operation and Maintenance Data: For drainage piping specialties to include in emergency, operation, and maintenance manuals.

1.5 QUALITY ASSURANCE

- A. Drainage piping specialties shall bear label, stamp, or other markings of specified testing agency.
- B. Electrical Components, Devices, and Accessories: Listed and labeled as defined in NFPA 70, Article 100, by a testing agency acceptable to authorities having jurisdiction, and marked for intended use.
- C. Comply with NSF 14, "Plastics Piping Components and Related Materials," for plastic sanitary piping specialty components.

1.6 COORDINATION

- A. Coordinate size and location of concrete bases. Cast anchor-bolt inserts into bases. Concrete, reinforcement, and formwork requirements are specified in Division 03.
- B. Coordinate size and location of roof penetrations.

PART 2 - PRODUCTS

2.1 CLEANOUTS

- A. Exposed Metal Cleanouts:
 - 1. Manufacturers: Subject to compliance with requirements, provide products by one of the following:
 - a. Josam Company; Josam Div.

- b. Smith, Jay R. Mfg. Co.; Division of Smith Industries, Inc.
 - c. Tyler Pipe; Wade Div.
 - d. Zurn Plumbing Products Group; Specification Drainage Operation.
 2. Standard: ASME A112.36.2M for cast iron ASME A112.3.1 for stainless steel for cleanout test tee.
 3. Size: Same as connected drainage piping
 4. Body Material: Hub-and-spigot, cast-iron soil pipe T-branch and Hubless, cast-iron soil pipe test tee as required to match connected piping.
 5. Closure: Countersunk, brass cast-iron plastic plug.
 6. Closure Plug Size: Same as or not more than one size smaller than cleanout size.
 7. Closure: Stainless-steel plug with seal.
- B. Metal Floor Cleanouts:
 1. Manufacturers: Subject to compliance with requirements, provide products by one of the following:
 - a. Josam Company; Josam Div.
 - b. Smith, Jay R. Mfg. Co.; Division of Smith Industries, Inc.
 - c. Tyler Pipe; Wade Div.
 - d. Zurn Plumbing Products Group; Specification Drainage Operation.
 2. Standard: ASME A112.36.2M for adjustable housing heavy-duty, adjustable housing cleanout.
 3. Size: Same as connected branch.
 4. Type: Adjustable housing Heavy-duty, adjustable housing.
 5. Body or Ferrule: Cast iron .
 6. Clamping Device: Required.
 7. Outlet Connection: Threaded.
 8. Closure: Brass plug with straight threads and gasket.
 9. Adjustable Housing Material: Cast iron with threads.
 10. Frame and Cover Material and Finish: Nickel-bronze, copper alloy .
 11. Frame and Cover Shape: Round Square.
 12. Top Loading Classification: Extra Heavy Duty.
 13. Riser: ASTM A 74, Service class, cast-iron drainage pipe fitting and riser to cleanout.
 14. Standard: ASME A112.3.1.
 15. Size: Same as connected branch.
 16. Housing: Stainless steel.
 17. Closure: Stainless steel with seal.
 18. Riser: Stainless-steel drainage pipe fitting to cleanout.
- C. Cast-Iron Wall Cleanouts:
 1. Manufacturers: Subject to compliance with requirements, provide products by one of the following:
 - a. Josam Company; Josam Div.
 - b. Smith, Jay R. Mfg. Co.; Division of Smith Industries, Inc.
 - c. Tyler Pipe; Wade Div.
 - d. Zurn Plumbing Products Group; Specification Drainage Operation.
 2. Standard: ASME A112.36.2M. Include wall access.
 3. Size: Same as connected drainage piping.
 4. Body: Hub-and-spigot, cast-iron soil pipe T-branch and Hubless, cast-iron soil pipe test tee as required to match connected piping.
 5. Closure: Countersunk, brass cast-iron plug.

6. Closure Plug Size: Same as or not more than one size smaller than cleanout size.
7. Wall Access: Round, flat, chrome-plated brass or stainless-steel cover plate with screw.
8. Wall Access: Round wall-installation frame and cover.

2.2 FLOOR DRAINS

A. Cast-Iron Floor Drains:

1. Manufacturers: Subject to compliance with requirements, provide products by one of the following:
 - a. Josam Company; Josam Div.
 - b. Smith, Jay R. Mfg. Co.; Division of Smith Industries, Inc.
 - c. Tyler Pipe; Wade Div.
 - d. Zurn Plumbing Products Group; Specification Drainage Operation.
2. Drains shall be as scheduled on the plans.

2.3 TRENCH DRAINS

A. Trench Drains:

1. Manufacturers: Subject to compliance with requirements, provide products by one of the following:
 - a. Josam Company; Josam Div.
 - b. Smith, Jay R. Mfg. Co.; Division of Smith Industries, Inc.
 - c. Tyler Pipe; Wade Div.
 - d. Zurn Plumbing Products Group; Specification Drainage Operation.
2. Drains shall be as scheduled on the plans..

2.4 ROOF FLASHING ASSEMBLIES

A. Roof Flashing Assemblies:

1. Manufacturers: Subject to compliance with requirements, provide products by one of the following:
 - a. Acorn Engineering Company; Elmdor/Stoneman Div.
 - b. Thaler Metal Industries Ltd.

B. Description: Manufactured assembly made of 6.0-lb/sq. ft. (30-kq/sq. m), 0.0938-inch- (2.4-mm-) thick, lead flashing collar and skirt extending at least 10 inches (250 mm) from pipe, with galvanized-steel boot reinforcement and counterflashing fitting.

1. Open-Top Vent Cap: Without cap.
2. Low-Silhouette Vent Cap: With vandal-proof vent cap.
3. Extended Vent Cap: With field-installed, vandal-proof vent cap.

2.5 THROUGH-PENETRATION FIRESTOP ASSEMBLIES

A. Through-Penetration Firestop Assemblies:

1. Manufacturers: Subject to compliance with requirements, provide products by one of the following:
 - a. ProSet Systems Inc.
2. Standard: UL 1479 assembly of sleeve and stack fitting with firestopping plug.
3. Size: Same as connected soil, waste, or vent stack.

4. Sleeve: Molded PVC plastic, of length to match slab thickness and with integral nailing flange on one end for installation in cast-in-place concrete slabs.
5. Stack Fitting: ASTM A 48/A 48M, gray-iron, hubless-pattern, wye branch with neoprene O-ring at base and gray-iron plug in thermal-release harness. Include PVC protective cap for plug.
6. Special Coating: Corrosion resistant on interior of fittings.

2.6 MISCELLANEOUS SANITARY DRAINAGE PIPING SPECIALTIES

A. Open End Drains:

1. Description: Shop or field fabricate from ASTM A 74, Service class, hub-and-spigot, cast-iron, soil-pipe fittings. Include P-trap, hub-and-spigot riser section; and where required, increaser fitting joined with ASTM C 564, rubber gaskets.
2. Size: Same as connected waste piping with increaser fitting of size indicated.

B. Deep-Seal Traps:

1. Description: Cast-iron or bronze casting, with inlet and outlet matching connected piping and cleanout trap-seal primer valve connection.
2. Size: Same as connected waste piping.
 - a. NPS 2 (DN 50): 4-inch- (100-mm-) minimum water seal.
 - b. NPS 2-1/2 (DN 65) and Larger: 5-inch- (125-mm-) minimum water seal.

C. Floor-Drain, Trap-Seal Primer Fittings:

1. Description: Cast iron, with threaded inlet and threaded or spigot outlet, and trap-seal primer valve connection.
2. Size: Same as floor drain outlet with NPS 1/2 (DN 15) side inlet.

D. Air-Gap Fittings:

1. Standard: ASME A112.1.2, for fitting designed to ensure fixed, positive air gap between installed inlet and outlet piping.
2. Body: Bronze or cast iron.
3. Inlet: Opening in top of body.
4. Outlet: Larger than inlet.
5. Size: Same as connected waste piping and with inlet large enough for associated indirect waste piping.

E. Sleeve Flashing Device:

1. Description: Manufactured, cast-iron fitting, with clamping device, that forms sleeve for pipe floor penetrations of floor membrane. Include galvanized-steel pipe extension in top of fitting that will extend 2 inches (51 mm) above finished floor and galvanized-steel pipe extension in bottom of fitting that will extend through floor slab.
2. Size: As required for close fit to riser or stack piping.

F. Stack Flashing Fittings:

1. Description: Counterflashing-type, cast-iron fitting, with bottom recess for terminating roof membrane, and with threaded or hub top for extending vent pipe.
2. Size: Same as connected stack vent or vent stack.

G. Vent Caps:

1. Description: Cast-iron body with threaded or hub inlet and vandal-proof design. Include vented hood and setscrews to secure to vent pipe.
2. Size: Same as connected stack vent or vent stack.

H. Frost-Resistant Vent Terminals:

1. Description: Manufactured or shop-fabricated assembly constructed of copper, lead-coated copper, or galvanized steel.
2. Design: To provide 1-inch (25-mm) enclosed air space between outside of pipe and inside of flashing collar extension, with counterflashing.

I. Expansion Joints:

1. Standard: ASME A112.21.2M.
2. Body: Cast iron with bronze sleeve, packing, and gland.
3. End Connections: Matching connected piping.
4. Size: Same as connected soil, waste, or vent piping.

2.7 FLASHING MATERIALS

- A. Lead Sheet: ASTM B 749, Type L51121, copper bearing, with the following minimum weights and thicknesses, unless otherwise indicated:
1. General Use: 4.0-lb/sq. ft. (20-kg/sq. m), 0.0625-inch (1.6-mm) thickness.
 2. Vent Pipe Flashing: 3.0-lb/sq. ft. (15-kg/sq. m), 0.0469-inch (1.2-mm) thickness.
 3. Burning: 6-lb/sq. ft. (30-kg/sq. m), 0.0938-inch (2.4-mm) thickness.
- B. Copper Sheet: ASTM B 152/B 152M, of the following minimum weights and thicknesses, unless otherwise indicated:
1. General Applications: 12 oz./sq. ft. (3.7 kg/sq. m or 0.41-mm thickness).
 2. Vent Pipe Flashing: 8 oz./sq. ft. (2.5 kg/sq. m or 0.27-mm thickness).
- C. Zinc-Coated Steel Sheet: ASTM A 653/A 653M, with 0.20 percent copper content and 0.04-inch (1.01-mm) minimum thickness, unless otherwise indicated. Include G90 (Z275) hot-dip galvanized, mill-phosphatized finish for painting if indicated.
- D. Elastic Membrane Sheet: ASTM D 4068, flexible, chlorinated polyethylene, 40-mil (1.01-mm) minimum thickness.
- E. Fasteners: Metal compatible with material and substrate being fastened.
- F. Metal Accessories: Sheet metal strips, clamps, anchoring devices, and similar accessory units required for installation; matching or compatible with material being installed.
- G. Solder: ASTM B 32, lead-free alloy.
- H. Bituminous Coating: SSPC-Paint 12, solvent-type, bituminous mastic.

2.8 SOLIDS INTERCEPTORS

1. Manufacturers: Subject to compliance with requirements, provide products by one of the following:
 - a. Josam Company; Josam Div.
 - b. Smith, Jay R. Mfg. Co.; Division of Smith Industries, Inc.
 - c. Tyler Pipe; Wade Div.
 - d. Zurn Plumbing Products Group; Specification Drainage Operation.
2. Type: Factory-fabricated interceptor made for removing and retaining plaster from wastewater.

3. Body Material: Cast iron or steel.
4. Interior Separation Device: Screens.
5. Interior Lining: Corrosion-resistant enamel.
6. Exterior Coating: Corrosion-resistant enamel.
7. Body Dimensions: Per Mfg.
8. Flow Rate: Not required.
9. Inlet and Outlet Size: 2".
10. End Connections: Threaded.
11. Mounting: Inline.

PART 3 - EXECUTION

3.1 INSTALLATION

- A. Refer to Division 22 Section "Common Work Results for Plumbing" for piping joining materials, joint construction, and basic installation requirements.
- B. Install cleanouts in aboveground piping and building drain piping according to the following, unless otherwise indicated:
 1. Size same as drainage piping up to NPS 4 (DN 100). Use NPS 4 (DN 100) for larger drainage piping unless larger cleanout is indicated.
 2. Locate at each change in direction of piping greater than 45 degrees.
 3. Locate at minimum intervals of 50 feet (15 m) for piping NPS 4 (DN 100) and smaller and 100 feet (30 m) for larger piping.
 4. Locate at base of each vertical soil and waste stack.
- C. For floor cleanouts for piping below floors, install cleanout deck plates with top flush with finished floor.
- D. For cleanouts located in concealed piping, install cleanout wall access covers, of types indicated, with frame and cover flush with finished wall.
- E. Install floor drains at low points of surface areas to be drained. Set grates of drains flush with finished floor, unless otherwise indicated.
 1. Position floor drains for easy access and maintenance.
 2. Set floor drains below elevation of surrounding finished floor to allow floor drainage. Set with grates depressed according to the following drainage area radii:
 - a. Radius, 30 Inches (750 mm) or Less: Equivalent to 1 percent slope, but not less than 1/4-inch (6.35-mm) total depression.
 - b. Radius, 30 to 60 Inches (750 to 1500 mm): Equivalent to 1 percent slope.
 - c. Radius, 60 Inches (1500 mm) or Larger: Equivalent to 1 percent slope, but not greater than 1-inch (25-mm) total depression.
 3. Install floor-drain flashing collar or flange so no leakage occurs between drain and adjoining flooring. Maintain integrity of waterproof membranes where penetrated.
 4. Install individual traps for floor drains connected to sanitary building drain, unless otherwise indicated.
- F. Install trench drains at low points of surface areas to be drained. Set grates of drains flush with finished surface, unless otherwise indicated.
- G. Install fixture air-admittance valves on fixture drain piping.

- H. Install stack air-admittance valves at top of stack vent and vent stack piping.
- I. Install air-admittance-valve wall boxes recessed in wall.
- J. Install roof flashing assemblies on sanitary stack vents and vent stacks that extend through roof.
- K. Install flashing fittings on sanitary stack vents and vent stacks that extend through roof.
- L. Install through-penetration firestop assemblies in plastic stacks at floor penetrations.
- M. Assemble open drain fittings and install with top of hub 2 inches (51 mm) above floor.
- N. Install deep-seal traps on floor drains and other waste outlets, if indicated.
- O. Install floor-drain, trap-seal primer fittings on inlet to floor drains that require trap-seal primer connection.
 - 1. Exception: Fitting may be omitted if trap has trap-seal primer connection.
 - 2. Size: Same as floor drain inlet.
- P. Install air-gap fittings on draining-type backflow preventers and on indirect-waste piping discharge into sanitary drainage system.
- Q. Install sleeve flashing device with each riser and stack passing through floors with waterproof membrane.
- R. Install vent caps on each vent pipe passing through roof.
- S. Install frost-resistant vent terminals on each vent pipe passing through roof. Maintain 1-inch (25-mm) clearance between vent pipe and roof substrate.
- T. Install expansion joints on vertical stacks and conductors. Position expansion joints for easy access and maintenance.
- U. Install frost-proof vent caps on each vent pipe passing through roof. Maintain 1-inch (25-mm) clearance between vent pipe and roof substrate.
- V. Install solids interceptors with cleanout immediately downstream from interceptors that do not have integral cleanout on outlet. Install trap on interceptors that do not have integral trap and are connected to sanitary drainage and vent systems.
- W. Install traps on plumbing specialty drain outlets. Omit traps on indirect wastes unless trap is indicated.
- X. Install escutcheons at wall, floor, and ceiling penetrations in exposed finished locations and within cabinets and millwork. Use deep-pattern escutcheons if required to conceal protruding pipe fittings.

3.2 CONNECTIONS

- A. Piping installation requirements are specified in other Division 22 Sections. Drawings indicate general arrangement of piping, fittings, and specialties.
- B. Install piping adjacent to equipment to allow service and maintenance.

3.3 FLASHING INSTALLATION

- A. Fabricate flashing from single piece unless large pans, sumps, or other drainage shapes are required. Join flashing according to the following if required:
 - 1. Lead Sheets: Burn joints of lead sheets 6.0-lb/sq. ft. (30-kg/sq. m), 0.0938-inch (2.4-mm) thickness or thicker. Solder joints of lead sheets 4.0-lb/sq. ft. (20-kg/sq. m), 0.0625-inch (1.6-mm) thickness or thinner.
 - 2. Copper Sheets: Solder joints of copper sheets.
- B. Install sheet flashing on pipes, sleeves, and specialties passing through or embedded in floors and roofs with waterproof membrane.
 - 1. Pipe Flashing: Sleeve type, matching pipe size, with minimum length of 10 inches (250 mm), and skirt or flange extending at least 8 inches (200 mm) around pipe.
 - 2. Sleeve Flashing: Flat sheet, with skirt or flange extending at least 8 inches (200 mm) around sleeve.
 - 3. Embedded Specialty Flashing: Flat sheet, with skirt or flange extending at least 8 inches (200 mm) around specialty.
- C. Set flashing on floors and roofs in solid coating of bituminous cement.
- D. Secure flashing into sleeve and specialty clamping ring or device.
- E. Install flashing for piping passing through roofs with counterflashing or commercially made flashing fittings, according to Division 07 Section "Sheet Metal Flashing and Trim."
- F. Extend flashing up vent pipe passing through roofs and turn down into pipe, or secure flashing into cast-iron sleeve having calking recess.
- G. Fabricate and install flashing and pans, sumps, and other drainage shapes.

3.4 LABELING AND IDENTIFYING

- A. Equipment Nameplates and Signs: Install engraved plastic-laminate equipment nameplate or sign on or near each of the following:
 - 1. Solids interceptors.
- B. Distinguish among multiple units, inform operator of operational requirements, indicate safety and emergency precautions, and warn of hazards and improper operations, in addition to identifying unit. Nameplates and signs are specified in Division 22 Section "Identification for Plumbing Piping and Equipment."

3.5 PROTECTION

- A. Protect drains during remainder of construction period to avoid clogging with dirt or debris and to prevent damage from traffic or construction work.
- B. Place plugs in ends of uncompleted piping at end of each day or when work stops.

END OF SECTION

This page is intentionally left blank.

Section 22 14 23

STORM DRAINAGE PIPING SPECIALTIES

PART 1 - GENERAL

1.1 RELATED DOCUMENTS

- A. Drawings and general provisions of the Contract, including General and Supplementary Conditions and Division 01 Specification Sections, apply to this Section.
- B. Section 01 81 13 "Sustainable Design Requirements – LEED v4 for Building Design & Construction – New Construction" for sustainable design requirements and detailed sustainable design submittal requirements.
- C. Section 01 74 19 "Construction and Demolition Waste Management and Disposal" for disposal of construction, demolition and packaging waste disposal requirements.

1.2 SUMMARY

- A. This Section includes the following storm drainage piping specialties:
 - 1. Cleanouts.
 - 2. Through-penetration firestop assemblies.
 - 3. Roof drains.
 - 4. Miscellaneous storm drainage piping specialties.
 - 5. Flashing materials.
- B. Related Sections include the following:
 - 1. Division 22 Section "Sanitary Waste Piping Specialties" for backwater valves, floor drains, trench drains and channel drainage systems connected to sanitary sewer, air admittance valves.
- C. Sustainable Building Requirements:
 - 1. The Owner requires the Contractor to implement practices and procedures to meet the project's environmental performance goals, which include achieving LEED version 4 **Certified** level Certification. Specific project goals that may impact this area of work include: use of recycled-content materials; use of locally-manufactured materials; use of low-emitting materials; construction waste recycling; and the implementation of a construction indoor air quality management plan. The Contractor shall ensure that the requirements related to these goals, as defined in the Articles below, are implemented to the fullest extent. Substitutions, or other changes to the work proposed by the Contractor or their Subcontractors, shall not be allowed if such changes compromise the aforementioned environmental goals and LEED certification.

1.3 DEFINITIONS

- A. ABS: Acrylonitrile-butadiene-styrene plastic.
- B. FOG: Fats, oils, and greases.
- C. FRP: Fiberglass-reinforced plastic.
- D. HDPE: High-density polyethylene plastic.
- E. PE: Polyethylene plastic.
- F. PP: Polypropylene plastic.
- G. PUR: Polyurethane plastic.
- H. PVC: Polyvinyl chloride plastic.

1.4 SUBMITTALS

- A. Product Data: For each type of product indicated.

1.5 QUALITY ASSURANCE

- A. Drainage piping specialties shall bear label, stamp, or other markings of specified testing agency.

1.6 COORDINATION

- A. Coordinate size and location of roof penetrations.

PART 2 - PRODUCTS

2.1 CLEANOUTS

- A. Exposed Metal Cleanouts:
 - 1. Available Manufacturers: Subject to compliance with requirements, manufacturers offering products that may be incorporated into the Work include, but are not limited to, the following:
 - 2. Manufacturers: Subject to compliance with requirements, provide products by one of the following:
 - 3. Basis-of-Design Product: Subject to compliance with requirements, provide the product indicated on Drawings or a comparable product by one of the following:
 - a. Josam Company; Josam Div.

- b. Smith, Jay R. Mfg. Co.; Division of Smith Industries, Inc.
 - c. Tyler Pipe; Wade Div.
 - d. Zurn Plumbing Products Group; Specification Drainage Operation.
4. Standard: ASME A112.36.2M for cast iron for cleanout test tee.
 5. Size: Same as connected drainage piping
 6. Body Material: Hub-and-spigot, cast-iron soil pipe T-branch and Hubless, cast-iron soil pipe test tee as required to match connected piping.
 7. Closure: Countersunk Raised-head, brass plug.
 8. Closure Plug Size: Same as or not more than one size smaller than cleanout size.
9. Closure: Stainless-steel plug with seal.
- B. Metal Floor Cleanouts:
1. Available Manufacturers: Subject to compliance with requirements, manufacturers offering products that may be incorporated into the Work include, but are not limited to, the following:
 2. Manufacturers: Subject to compliance with requirements, provide products by one of the following:
 3. Basis-of-Design Product: Subject to compliance with requirements, provide the product indicated on Drawings or a comparable product by one of the following:
 - a. Josam Company; Josam Div.
 - b. Smith, Jay R. Mfg. Co.; Division of Smith Industries, Inc.
 - c. Tyler Pipe; Wade Div.
 - d. Zurn Plumbing Products Group; Specification Drainage Operation.
4. Standard: ASME A112.36.2M for cast-iron soil pipe with cast-iron ferrule cleanout.
 5. Size: Same as connected branch.
 6. Type: Cast-iron soil pipe with cast-iron ferrule.
 7. Body or Ferrule: Cast iron.
 8. Clamping Device: Required.
 9. Outlet Connection: Inside calk.
 10. Closure: Brass plug with straight threads and gasket.
 11. Adjustable Housing Material: Cast iron with threads.
 12. Frame and Cover Material and Finish: Nickel-bronze, copper alloy.
 13. Frame and Cover Shape: Round.
 14. Top Loading Classification: Extra Heavy Duty.
 15. Riser: ASTM A 74, Extra-Heavy class, cast-iron drainage pipe fitting and riser to cleanout.
16. Standard: ASME A112.3.1.
 17. Size: Same as connected branch.
 18. Housing: Stainless steel.
 19. Closure: Stainless steel with seal.
 20. Riser: Stainless-steel drainage pipe fitting to cleanout.
- C. Cast-Iron Wall Cleanouts:

1. Available Manufacturers: Subject to compliance with requirements, manufacturers offering products that may be incorporated into the Work include, but are not limited to, the following:
2. Manufacturers: Subject to compliance with requirements, provide products by one of the following:
3. Basis-of-Design Product: Subject to compliance with requirements, provide the product indicated on Drawings or a comparable product by one of the following:
 - a. Josam Company; Josam Div.
 - b. Smith, Jay R. Mfg. Co.; Division of Smith Industries, Inc.
 - c. Tyler Pipe; Wade Div.
 - d. Zurn Plumbing Products Group; Specification Drainage Operation.
4. Standard: ASME A112.36.2M. Include wall access.
5. Size: Same as connected drainage piping.
6. Body: Hub-and-spigot, cast-iron soil pipe T-branch, Hubless, cast-iron soil pipe test tee as required to match connected piping.
7. Closure: Countersunk, brass plug.
8. Closure Plug Size: Same as or not more than one size smaller than cleanout size.
9. Wall Access: Round, flat, chrome-plated brass or stainless-steel cover plate with screw.
10. Wall Access: Round, stainless-steel wall-installation frame and cover.

2.2 THROUGH-PENETRATION FIRESTOP ASSEMBLIES

A. Through-Penetration Firestop Assemblies:

1. Available Manufacturers: Subject to compliance with requirements, manufacturers offering products that may be incorporated into the Work include, but are not limited to, the following:
2. Manufacturers: Subject to compliance with requirements, provide products by one of the following:
 - a. ProSet Systems Inc.
3. Standard: UL 1479 assembly of sleeve and stack fitting with firestopping plug.
4. Size: Same as connected pipe.
5. Sleeve: Molded PVC plastic, of length to match slab thickness and with integral nailing flange on one end for installation in cast-in-place concrete slabs.
6. Stack Fitting: ASTM A 48/A 48M, gray-iron, hubless-pattern, wye branch with neoprene O-ring at base and gray-iron plug in thermal-release harness. Include PVC protective cap for plug.
7. Special Coating: Corrosion resistant on interior of fittings.

2.3 ROOF DRAINS

A. Metal Roof Drains:

1. Available Manufacturers: Subject to compliance with requirements, manufacturers offering products that may be incorporated into the Work include, but are not limited to, the following:
2. Manufacturers: Subject to compliance with requirements, provide products by one of the following:
3. Basis-of-Design Product: Subject to compliance with requirements, provide the product indicated on Drawings or a comparable product by one of the following:
 - a. Smith, Jay R. Mfg. Co.; Division of Smith Industries, Inc.
 - b. Tyler Pipe; Wade Div.
4. Standard: ASME A112.21.2M.
5. Pattern: Roof drain.
6. Body Material: Cast iron.
7. Dimensions of Body: As noted on the drawings.
8. Combination Flashing Ring and Gravel Stop: Required.
9. Flow-Control Weirs: Not required.
10. Outlet: Bottom.
11. Dome Material: Cast iron.
12. Extension Collars: Required.
13. Underdeck Clamp: Required.
14. Sump Receiver: Required.

2.4 MISCELLANEOUS STORM DRAINAGE PIPING SPECIALTIES

A. Expansion Joints:

1. Standard: ASME A112.21.2M.
2. Body: Cast iron with bronze sleeve, packing, and gland.
3. End Connections: Matching connected piping.
4. Size: Same as connected piping.

2.5 FLASHING MATERIALS

- A. Copper Sheet: ASTM B 152/B 152M, 12 oz./sq. ft. (3.7 kg/sq. m or 0.41-mm) thickness.
- B. Zinc-Coated Steel Sheet: ASTM A 653/A 653M, with 0.20 percent copper content and 0.04-inch (1.01-mm) minimum thickness, unless otherwise indicated. Include G90 (Z275) hot-dip galvanized, mill-phosphatized finish for painting if indicated.
- C. Elastic Membrane Sheet: ASTM D 4068, flexible, chlorinated polyethylene, 40-mil (1.01-mm) minimum thickness.
- D. Fasteners: Metal compatible with material and substrate being fastened.

- E. Metal Accessories: Sheet metal strips, clamps, anchoring devices, and similar accessory units required for installation; matching or compatible with material being installed.
- F. Solder: ASTM B 32, lead-free alloy.
- G. Bituminous Coating: SSPC-Paint 12, solvent-type, bituminous mastic.

PART 3 - EXECUTION

3.1 INSTALLATION

- A. Refer to Division 22 Section "Common Work Results for Plumbing" for piping joining materials, joint construction, and basic installation requirements.
- B. Install cleanouts in aboveground piping and building drain piping according to the following, unless otherwise indicated:
 - 1. Size same as drainage piping up to NPS 4 (DN 100). Use NPS 4 (DN 100) for larger drainage piping unless larger cleanout is indicated.
 - 2. Locate at each change in direction of piping greater than 45 degrees.
 - 3. Locate at minimum intervals of 50 feet (15 m) for piping NPS 4 (DN 100) and smaller and 100 feet (30 m) for larger piping.
 - 4. Locate at base of each vertical soil and waste stack.
- C. For floor cleanouts for piping below floors, install cleanout deck plates with top flush with finished floor.
- D. For cleanouts located in concealed piping, install cleanout wall access covers, of types indicated, with frame and cover flush with finished wall.
- E. Install trench drains at low points of surface areas to be drained. Set grates of drains flush with finished surface, unless otherwise indicated.
- F. Install through-penetration firestop assemblies in plastic conductors and stacks at floor penetrations.
- G. Install roof drains at low points of roof areas according to roof membrane manufacturer's written installation instructions. Roofing materials are specified in Division 07.
 - 1. Install roof-drain flashing collar or flange so that there will be no leakage between drain and adjoining roofing. Maintain integrity of waterproof membranes where penetrated.
 - 2. Position roof drains for easy access and maintenance.
- H. Install sleeve flashing device with each riser and stack passing through floors with waterproof membrane.

- I. Install expansion joints on vertical stacks and conductors. Position expansion joints for easy access and maintenance.
- J. Install conductor nozzles at exposed bottom of conductors where they spill onto grade.
- K. Install escutcheons at wall, floor, and ceiling penetrations in exposed finished locations and within cabinets and millwork. Use deep-pattern escutcheons if required to conceal protruding pipe fittings.

3.2 CONNECTIONS

- A. Piping installation requirements are specified in other Division 22 Sections. Drawings indicate general arrangement of piping, fittings, and specialties.

3.3 FLASHING INSTALLATION

- A. Fabricate flashing from single piece unless large pans, sumps, or other drainage shapes are required. Join flashing according to the following if required:
 - 1. Lead Sheets: Burn joints of lead sheets 6.0-lb/sq. ft. (30-kg/sq. m), 0.0938-inch (2.4-mm) thickness or thicker. Solder joints of lead sheets 4.0-lb/sq. ft. (20-kg/sq. m), 0.0625-inch (1.6-mm) thickness or thinner.
 - 2. Copper Sheets: Solder joints of copper sheets.
- B. Install sheet flashing on pipes, sleeves, and specialties passing through or embedded in floors and roofs with waterproof membrane.
 - 1. Pipe Flashing: Sleeve type, matching pipe size, with minimum length of 10 inches (250 mm), and skirt or flange extending at least 8 inches (200 mm) around pipe.
 - 2. Sleeve Flashing: Flat sheet, with skirt or flange extending at least 8 inches (200 mm) around sleeve.
 - 3. Embedded Specialty Flashing: Flat sheet, with skirt or flange extending at least 8 inches (200 mm) around specialty.
- C. Set flashing on floors and roofs in solid coating of bituminous cement.
- D. Secure flashing into sleeve and specialty clamping ring or device.
- E. Fabricate and install flashing and pans, sumps, and other drainage shapes.

3.4 PROTECTION

- A. Protect drains during remainder of construction period to avoid clogging with dirt or debris and to prevent damage from traffic or construction work.
- B. Place plugs in ends of uncompleted piping at end of each day or when work stops.

END OF SECTION

This page is intentionally left blank.

This page is intentionally left blank.

SECTION 22 35 00

DOMESTIC WATER HEAT EXCHANGERS

PART 1 - GENERAL

1.1 RELATED DOCUMENTS

- A. Drawings and general provisions of the Contract, including General and Supplementary Conditions and Division 01 Specification Sections, apply to this Section.
- B. Section 01 81 13 "Sustainable Design Requirements – LEED v4 for Building Design & Construction – New Construction" for sustainable design requirements and detailed sustainable design submittal requirements.
- C. Section 01 74 19 "Construction and Demolition Waste Management and Disposal" for disposal of construction, demolition and packaging waste disposal requirements.

1.2 SUMMARY

- A. This Section includes the following heat exchangers:
 - 1. Heating-fluid-in-coil, instantaneous heat exchangers.
 - 2. Compression tanks.
 - 3. Heat-exchanger accessories.
- B. Sustainable Building Requirements:
 - 1. The Owner requires the Contractor to implement practices and procedures to meet the project's environmental performance goals, which include achieving LEED version 4 **Certified** level Certification. Specific project goals that may impact this area of work include: use of recycled-content materials; use of locally-manufactured materials; use of low-emitting materials; construction waste recycling; and the implementation of a construction indoor air quality management plan. The Contractor shall ensure that the requirements related to these goals, as defined in the Articles below, are implemented to the fullest extent. Substitutions, or other changes to the work proposed by the Contractor or their Subcontractors, shall not be allowed if such changes compromise the aforementioned environmental goals and LEED certification.

1.3 SUBMITTALS

- A. Product Data: For each type and size of heat exchanger indicated. Include rated capacities, operating characteristics, furnished specialties, and accessories.
- B. Shop Drawings: Diagram power, signal, and control wiring.

- C. Product Certificates: For each type of instantaneous heat exchanger, signed by product manufacturer.
- D. Manufacturer Seismic Qualification Certification: Submit certification that heat exchangers, accessories, and components will withstand seismic forces defined in Division 15 Section "Vibration and Seismic Controls for Plumbing Piping and Equipment." Include the following:
 - 1. Basis for Certification: Indicate whether withstand certification is based on actual test of assembled components or on calculation.
 - a. The term "withstand" means "the unit will remain in place without separation of any parts from the device when subjected to the seismic forces specified."
 - b. The term "withstand" means "the unit will remain in place without separation of any parts from the device when subjected to the seismic forces specified and the unit will be fully operational after the seismic event."
 - 2. Dimensioned Outline Drawings of Equipment Unit: Identify center of gravity and locate and describe mounting and anchorage provisions.
 - 3. Detailed description of equipment anchorage devices on which the certification is based and their installation requirements.
- E. Source quality-control test reports.
- F. Field quality-control test reports.
- G. Operation and Maintenance Data: For heat exchangers to include in emergency, operation, and maintenance manuals.
- H. Warranty: Special warranty specified in this Section.

1.4 QUALITY ASSURANCE

- A. Source Limitations: Obtain same type of heat exchangers through one source from a single manufacturer.
- B. Product Options: Drawings indicate size, profiles, and dimensional requirements of heat exchangers and are based on the specific system indicated. Refer to Division 01 Section "Product Requirements."
- C. Electrical Components, Devices, and Accessories: Listed and labeled as defined in NFPA 70, Article 100, by a testing agency acceptable to authorities having jurisdiction, and marked for intended use.
- D. ASME Compliance: Where ASME-code construction is indicated, fabricate and label heat-exchanger storage tanks to comply with ASME Boiler and Pressure Vessel Code: Section VIII, Division 1.

- E. Comply with NSF 61, "Drinking Water System Components - Health Effects; Sections 1 through 9" for all components that will be in contact with water.

1.5 COORDINATION

- A. Coordinate size and location of concrete bases with Architectural and Structural Drawings.

1.6 WARRANTY

- A. Special Warranty: Manufacturer's standard form in which manufacturer agrees to repair or replace components of heat exchangers that fail in materials or workmanship within specified warranty period.

- 1. Failures include, but are not limited to, the following:
 - a. Structural failures including heat exchanger, storage tank, and supports.
 - b. Faulty operation of controls.
 - c. Deterioration of metals, metal finishes, and other materials beyond normal use.
- 2. Warranty Period(s): From date of Substantial Completion:
 - a. Instantaneous Heat Exchangers:
 - 1) Tube Coil and Shell: One year(s).
 - 2) Controls and Other Components: One year(s).
 - b. Compression Tanks: One year(s).

PART 2 - PRODUCTS

2.1 MANUFACTURERS

- A. In other Part 2 articles where titles below introduce lists, the following requirements apply to product selection:
 - 1. Available Manufacturers: Subject to compliance with requirements, manufacturers offering products that may be incorporated into the Work include, but are not limited to, manufacturers specified.
 - 2. Manufacturers: Subject to compliance with requirements, provide products by one of the manufacturers specified.

2.2 INSTANTANEOUS HEAT EXCHANGERS

- A. Heating-Fluid-in-Coil, Instantaneous Heat Exchangers:

1. Manufacturers:
 - a. Patterson Kelly
 - b. AERCO International, Inc.
2. Description: Packaged assembly of tank, heat-exchanger coils, controls, and specialties for heating domestic water with steam in heat-exchanger coils.
3. Construction: ASME-code, negligible-capacity, copper-lined, carbon-steel shell with 150-psig (1035-kPa) minimum working-pressure rating.
 - a. Tappings: Factory fabricated of materials compatible with heat-exchanger shell. Attach tappings to shell before testing and labeling.
 - 1) NPS 2 (DN 50) and Smaller: Threaded ends according to ASME B1.20.1.
 - 2) NPS 2-1/2 (DN 65) and Larger: Flanged ends according to ASME B16.5 for steel and stainless-steel flanges, and according to ASME B16.24 for copper and copper-alloy flanges.
 - b. Insulation: Complying with ASHRAE/IESNA 90.1, unless otherwise indicated, and suitable for operating temperature. Surround entire shell and nozzle except connections and controls.
 - c. Heat-Exchanger Coils: Copper, helix-wound coils for heating fluid with pressure rating equal to or greater than heating-fluid supply pressure.
 - d. Temperature Control: Adjustable thermostat that operates control valve and that is capable of maintaining outlet-water temperature within 4 deg F (2 deg C) of setting.
 - e. Safety Control: Automatic, high-temperature-limit cutoff device or system.
 - f. Relief Valves: ASME rated and stamped and complying with ASME PTC 25.3, for combination temperature and pressure relief valves. Include one or more relief valves with total relieving capacity at least as great as heat input, and include pressure setting less than working-pressure rating of heat exchanger. Select one relief valve with sensing element that extends into storage tank.
4. Miscellaneous Components for Heating Hot-Water Unit: Control valve, valves, and piping.
5. Miscellaneous Components for Steam Unit: Strainers, steam-control valve, steam trap, valves, pressure gage, thermometer, and piping.
 - a. Exception: Steam trap is not required if manufacturer's written instructions direct that it not be used.
6. Stand: Factory fabricated for floor mounting.
7. Capacity and Characteristics:
 - a. Flow Rate: 30 gpm at 100 deg F (56 deg C) temperature rise.
 - b. Hot-Water Temperature Setting: 140 deg F.
 - c. Heating Hot-Water Supply:
 - 1) Inlet Temperature: 40 deg F.

- 2) Outlet Temperature: 40 deg F .
 - 3) Pipe Size: 1 ½ NPS (DN).
- d. Steam Supply:
- 1) Inlet Pressure: 15 psig (kPa).
- e. Condensate Pipe Size: Insert NPS (DN).
- f. Electrical Characteristics:
- 1) Volts: 115V.
 - 2) Phases: Single I.
 - 3) Hertz: 60.

2.3 COMPRESSION TANKS

- A. Description: Steel, pressure-rated tank constructed with welded joints and factory-installed, butyl-rubber diaphragm. Include air precharge to minimum system-operating pressure at tank.
1. Manufacturers:
 - a. AMTROL Inc.
 - b. Watts Regulator Co.
 - c. Wessels Co.
 2. Construction:
 - a. Tappings: Factory-fabricated steel, welded to tank before testing and labeling. Include ASME B1.20.1 pipe thread.
 - b. Interior Finish: Comply with NSF 61 barrier materials for potable-water tank linings, including extending finish into and through tank fittings and outlets.
 - c. Air-Charging Valve: Factory installed.
 3. Capacity and Characteristics:
 - a. Working-Pressure Rating 150 psig (1035 kPa).
 - b. Capacity Acceptable 7 gal. (26.5 L) 10 gal. (37.9 L) minimum.

2.4 HEAT-EXCHANGER ACCESSORIES

- A. Combination Temperature and Pressure Relief Valves: ASME rated and stamped and complying with ASME PTC 25.3. Include relieving capacity at least as great as heat input, and include pressure setting less than working-pressure rating of heat exchanger. Select relief valves with sensing element that extends into heat-exchanger storage tank.

- B. Pressure Relief Valves: ASME rated and stamped and complying with ASME PTC 25.3. Include pressure setting less than working-pressure rating of heat exchanger.
- C. Piping-Type Heat Traps: Field-fabricated piping arrangement according to ASHRAE/IESNA 90.1 or ASHRAE 90.2.

2.5 SOURCE QUALITY CONTROL

- A. Test and inspect heat-exchanger storage tanks, specified to be ASME-code construction, according to ASME Boiler and Pressure Vessel Code.
- B. Hydrostatically test commercial heat-exchanger storage tanks before shipment to minimum of one and one-half times pressure rating.
- C. Prepare test reports.

PART 3 - EXECUTION

3.1 HEAT-EXCHANGER INSTALLATION

- A. Install heat exchangers on concrete bases.
 - 1. Concrete base construction requirements are specified in Division 22 Section "Common Work Results for Plumbing."
- B. Install heat exchangers level and plumb, according to layout drawings, original design, and referenced standards. Maintain manufacturer's recommended clearances. Arrange units so controls and devices needing service are accessible.
- C. Anchor heat exchangers to substrate.
- D. Install seismic restraints for heat exchangers. Anchor to substrate.
- E. Install temperature and pressure relief valves in top portion of storage tank shells of heat exchangers with domestic water storage. Use relief valves with sensing elements that extend into shells. Extend relief-valve outlet, with drain piping same as water piping in continuous downward pitch, and discharge by positive air gap onto closest floor drain.
- F. Install combination temperature and pressure relief valves in water piping for heat exchangers without storage. Extend relief-valve outlet, with drain piping same as water piping in continuous downward pitch, and discharge by positive air gap onto closest floor drain.
- G. Install heat-exchanger drain piping as indirect waste to spill by positive air gap into open drains or over floor drains. Install hose-end drain valves at low points in water piping for heat exchangers that do not have tank drains. Refer to Division 22 Section "Domestic Water Piping Specialties" for hose-end drain valves.

- H. Install thermometer on each heat-exchanger domestic-water inlet and outlet piping, and install thermometer on each heat-exchanger heating-fluid inlet and outlet piping. Refer to Division 22 Section "Meters and Gages for Plumbing Piping" for thermometers.
- I. Install pressure gages on heat-exchanger heating-fluid piping. Refer to Division 22 Section "Meters and Gages for Plumbing Piping" for pressure gages.
- J. Fill heat exchangers with water.
- K. Charge compression tanks with air.

3.2 CONNECTIONS

- A. Piping installation requirements are specified in other Division 22 Sections. Drawings indicate general arrangement of piping, fittings, and specialties.
- B. Install piping adjacent to heat exchangers to allow service and maintenance. Arrange piping for easy removal of heat exchangers.
- C. Ground equipment according to Division 26 Section "Grounding and Bonding for Electrical Systems."
- D. Connect wiring according to Division 26 Section "Low-Voltage Electrical Power Conductors and Cables."

3.3 FIELD QUALITY CONTROL

- A. Manufacturer's Field Service: Engage a factory-authorized service representative to inspect, test, and adjust field-assembled components and equipment installation, including connections, and to assist in field testing. Report results in writing.
- B. Perform the following field tests and inspections and prepare test reports:
 - 1. Leak Test: After installation, test for leaks. Repair leaks and retest until no leaks exist.
 - 2. Operational Test: After electrical circuitry has been energized, confirm proper operation.
 - 3. Test and adjust controls and safeties. Replace damaged and malfunctioning controls and equipment.
- C. Remove and replace heat exchangers that do not pass tests and inspections and retest as specified above.

3.4 DEMONSTRATION

- A. Engage a factory-authorized service representative to train Owner's maintenance personnel to adjust, operate, and maintain heat exchangers. Refer to Division 01 Section "Demonstration and Training."

END OF SECTION

SECTION 22 40 00
PLUMBING FIXTURES

PART 1 - GENERAL

1.1 RELATED DOCUMENTS

- A. Drawings and general provisions of the Contract, including General and Supplementary Conditions and Division 01 Specification Sections, apply to this Section.
- B. Section 01 81 13 "Sustainable Design Requirements – LEED v4 for Building Design & Construction – New Construction" for sustainable design requirements and detailed sustainable design submittal requirements.
- C. Section 01 74 19 "Construction and Demolition Waste Management and Disposal" for disposal of construction, demolition and packaging waste disposal requirements.

1.2 SUMMARY

- A. This Section includes the following conventional plumbing fixtures and related components:
 - 1. Faucets for lavatories.
 - 2. Laminar-flow faucet-spout outlets.
 - 3. Flushometers.
 - 4. Toilet seats.
 - 5. Protective shielding guards.
 - 6. Fixture supports.
 - 7. Shower receptors.
 - 8. Water closets.
 - 9. Urinals.
 - 10. Lavatories.
 - 11. Commercial sinks.
 - 12. Individual showers.
 - 13. Service sinks.
- B. Related Sections include the following:
 - 1. Division 10 Section "Toilet, Bath, and Laundry Accessories."
 - 2. Division 22 Section "Domestic Water Piping Specialties" for backflow preventers, floor drains, and specialty fixtures not included in this Section.
 - 3. Division 22 Section "Domestic Water Filtration Equipment" for water filters.
 - 4. Division 22 Section "Healthcare Plumbing Fixtures."
 - 5. Division 22 Section "Emergency Plumbing Fixtures."
 - 6. Division 22 Section "Security Plumbing Fixtures."
 - 7. Division 22 Section "Drinking Fountains and Water Coolers."

8. Division 31 Section "Facility Water Distribution Piping" for exterior plumbing fixtures and hydrants.

C. Sustainable Building Requirements:

1. The Owner requires the Contractor to implement practices and procedures to meet the project's environmental performance goals, which include achieving LEED version 4 **Certified** level Certification. Specific project goals that may impact this area of work include: use of recycled-content materials; use of locally-manufactured materials; use of low-emitting materials; construction waste recycling; and the implementation of a construction indoor air quality management plan. The Contractor shall ensure that the requirements related to these goals, as defined in the Articles below, are implemented to the fullest extent. Substitutions, or other changes to the work proposed by the Contractor or their Subcontractors, shall not be allowed if such changes compromise the aforementioned environmental goals and LEED certification.

1.3 DEFINITIONS

- A. ABS: Acrylonitrile-butadiene-styrene plastic.
- B. Accessible Fixture: Plumbing fixture that can be approached, entered, and used by people with disabilities.
- C. Cast Polymer: Cast-filled-polymer-plastic material. This material includes cultured-marble and solid-surface materials.
- D. Cultured Marble: Cast-filled-polymer-plastic material with surface coating.
- E. Fitting: Device that controls the flow of water into or out of the plumbing fixture. Fittings specified in this Section include supplies and stops, faucets and spouts, shower heads and tub spouts, drains and tailpieces, and traps and waste pipes. Piping and general-duty valves are included where indicated.
- F. FRP: Fiberglass-reinforced plastic.
- G. PMMA: Polymethyl methacrylate (acrylic) plastic.
- H. PVC: Polyvinyl chloride plastic.
- I. Solid Surface: Nonporous, homogeneous, cast-polymer-plastic material with heat-, impact-, scratch-, and stain-resistance qualities.

1.4 SUBMITTALS

- A. Product Data: For each type of plumbing fixture indicated. Include selected fixture and trim, fittings, accessories, appliances, appurtenances, equipment, and supports. Indicate materials and finishes, dimensions, construction details, and flow-control rates.
- B. Shop Drawings: Diagram power, signal, and control wiring.

- C. Operation and Maintenance Data: For plumbing fixtures to include in emergency, operation, and maintenance manuals.
- D. Warranty: Special warranty specified in this Section.

1.5 QUALITY ASSURANCE

- A. Source Limitations: Obtain plumbing fixtures, faucets, and other components of each category through one source from a single manufacturer.
 - 1. Exception: If fixtures, faucets, or other components are not available from a single manufacturer, obtain similar products from other manufacturers specified for that category.
- B. Electrical Components, Devices, and Accessories: Listed and labeled as defined in NFPA 70, Article 100, by a testing agency acceptable to authorities having jurisdiction, and marked for intended use.
- C. Regulatory Requirements: Comply with requirements in ICC A117.1, "Accessible and Usable Buildings and Facilities "Americans with Disabilities Act" for plumbing fixtures for people with disabilities.
- D. Regulatory Requirements: Comply with requirements in Public Law 102-486, "Energy Policy Act," about water flow and consumption rates for plumbing fixtures.
- E. NSF Standard: Comply with NSF 61, "Drinking Water System Components--Health Effects," for fixture materials that will be in contact with potable water.
- F. Select combinations of fixtures and trim, faucets, fittings, and other components that are compatible.
- G. Comply with the following applicable standards and other requirements specified for plumbing fixtures:
 - 1. Enameled, Cast-Iron Fixtures: ASME A112.19.1M.
 - 2. Porcelain-Enameled, Formed-Steel Fixtures: ASME A112.19.4M.
 - 3. Slip-Resistant Bathing Surfaces: ASTM F 462.
 - 4. Solid-Surface-Material Lavatories and Sinks: ANSI/ICPA SS-1.
 - 5. Stainless-Steel Commercial, Handwash Sinks: NSF 2 construction.
 - 6. Vitreous-China Fixtures: ASME A112.19.2M.
 - 7. Water-Closet, Flush Valve, ASME A112.19.5.
- H. Comply with the following applicable standards and other requirements specified for lavatory faucets:
 - 1. Backflow Protection Devices for Faucets with Side Spray: ASME A112.18.3M.
 - 2. Backflow Protection Devices for Faucets with Hose-Thread Outlet: ASME A112.18.3M.
 - 3. Diverter Valves for Faucets with Hose Spray: ASSE 1025.
 - 4. Faucets: ASME A112.18.1.

5. Hose-Connection Vacuum Breakers: ASSE 1011.
 6. Hose-Coupling Threads: ASME B1.20.7.
 7. Integral, Atmospheric Vacuum Breakers: ASSE 1001.
 8. NSF Potable-Water Materials: NSF 61.
 9. Pipe Threads: ASME B1.20.1.
 10. Sensor-Actuated Faucets and Electrical Devices: UL 1951.
 11. Supply Fittings: ASME A112.18.1.
 12. Brass Waste Fittings: ASME A112.18.2.
- I. Comply with the following applicable standards and other requirements specified for shower faucets:
1. Backflow Protection Devices for Hand-Held Showers: ASME A112.18.3M.
 2. Combination, Pressure-Equalizing and Thermostatic-Control Antiscald Faucets: ASSE 1016.
 3. Faucets: ASME A112.18.1.
 4. Hand-Held Showers: ASSE 1014.
 5. High-Temperature-Limit Controls for Thermal-Shock-Preventing Devices: ASTM F 445.
 6. Hose-Coupling Threads: ASME B1.20.7.
 7. Manual-Control Antiscald Faucets: ASTM F 444.
 8. Pipe Threads: ASME B1.20.1.
 9. Pressure-Equalizing-Control Antiscald Faucets: ASTM F 444 and ASSE 1016.
 10. Thermostatic-Control Antiscald Faucets: ASTM F 444 and ASSE 1016.
- J. Comply with the following applicable standards and other requirements specified for miscellaneous fittings:
1. Atmospheric Vacuum Breakers: ASSE 1001.
 2. Brass and Copper Supplies: ASME A112.18.1.
 3. Manual-Operation Flushometers: ASSE 1037.
 4. Brass Waste Fittings: ASME A112.18.2.
 5. Sensor-Operation Flushometers: ASSE 1037 and UL 1951.
- K. Comply with the following applicable standards and other requirements specified for miscellaneous components:
1. Flexible Water Connectors: ASME A112.18.6.
 2. Floor Drains: ASME A112.6.3.
 3. Hose-Coupling Threads: ASME B1.20.7.
 4. Off-Floor Fixture Supports: ASME A112.6.1M.
 5. Pipe Threads: ASME B1.20.1.
 6. Plastic Toilet Seats: ANSI Z124.5.
 7. Supply and Drain Protective Shielding Guards: ICC A117.1.
- 1.6 WARRANTY
- A. Special Warranties: Manufacturer's standard form in which manufacturer agrees to repair or replace components of whirlpools that fail in materials or workmanship within specified warranty period.

1. Failures include, but are not limited to, the following:
 - a. Structural failures of unit shell.
 - b. Faulty operation of controls, blowers, pumps, heaters, and timers.
 - c. Deterioration of metals, metal finishes, and other materials beyond normal use.
2. Warranty Period for Commercial Applications: 1 year from date of Substantial Completion.

1.7 EXTRA MATERIALS

- A. Furnish extra materials described below that match products installed and that are packaged with protective covering for storage and identified with labels describing contents.
 1. Faucet Washers and O-Rings: Equal to 10 percent of amount of each type and size installed.
 2. Faucet Cartridges and O-Rings: Equal to 5 percent of amount of each type and size installed.
 3. Flushometer Valve, Repair Kits: Equal to 10 percent of amount of each type installed, but no fewer than 12 of each type.

PART 2 - PRODUCTS

2.1 LAVATORY FAUCETS

- A. Lavatory Faucets:
 1. Available Manufacturers: Subject to compliance with requirements, manufacturers offering products that may be incorporated into the Work include, but are not limited to, the following:
 2. Manufacturers: Subject to compliance with requirements, provide products by one of the following:
 3. Basis-of-Design Product: Subject to compliance with requirements, provide the product indicated on Drawings or a comparable product by one of the following:
 - a. Chicago Faucets.
 - b. Toto, Inc.
 - c. T & S Brass and Bronze Works, Inc.
 4. Description: Two-handle mixing valve. Include hot- and cold-water indicators; coordinate faucet inlets with supplies and fixture holes; coordinate outlet with spout and fixture receptor.
 - a. Body Material: Commercial, solid brass.
 - b. Finish: Polished chrome plate.
 - c. Maximum Flow Rate: 0.5 gpm (1.5 L/min.).

- d. Centers: 4 inches (102 mm).
- e. Mounting: Deck, exposed.
- f. Valve Handle(s): Wrist blade, 4 inches (102 mm).
- g. Inlet(s): NPS 1/2 (DN 15) male shank] [NPS 1/2 (DN 15) female shank.
- h. Spout: Rigid, gooseneck type.
- i. Spout Outlet: Aerator, 0.5 gpm (1.5L/min.).
- j. Operation: Compression, manual.
- k. Drain: Grid.
- l. Tempering Device: Not required.

2.2 SHOWER FAUCETS

A. Shower Faucets:

- 1. Available Manufacturers: Subject to compliance with requirements, manufacturers offering products that may be incorporated into the Work include, but are not limited to, the following:
- 2. Manufacturers: Subject to compliance with requirements, provide products by one of the following:
- 3. Basis-of-Design Product: Subject to compliance with requirements, provide the product indicated on Drawings or a comparable product by one of the following:
 - a. Chicago Faucets.
 - b. Leonard Valve Company.
 - c. Symmons Industries, Inc.
- 4. Description: Single-handle pressure-balance valve. Include hot- and cold-water indicators; check stops; and shower head, arm, and flange. Coordinate faucet inlets with supplies and outlet with diverter valve.
 - a. Body Material: Solid brass.
 - b. Finish: Polished chrome plate.
 - c. Maximum Flow Rate: 2.5 gpm (9.5 L/min.), unless otherwise indicated.
 - d. Diverter Valve: Not required.
 - e. Mounting: Concealed.
 - f. Backflow Protection Device for Hand-Held Shower: Required.
 - g. Operation: Compression, manual.
 - h. Antiscald Device: Integral with mixing valve.
 - i. Check Stops: Check-valve type, integral with or attached to body; on hot- and cold-water supply connections.
 - j. Supply Connections: NPS 1/2 (DN 15)
 - k. Shower Head Type: Ball joint and head integral with mounting flange
 - l. Shower Head Material: Metallic with chrome-plated finish.
 - m. Spray Pattern: Fixed
 - n. Integral Volume Control: Required
 - o. Shower-Arm Flow-Control Fitting: Not required
 - p. Temperature Indicator: Not required

2.3 SINK FAUCETS

A. Sink Faucets:

1. Available Manufacturers: Subject to compliance with requirements, manufacturers offering products that may be incorporated into the Work include, but are not limited to, the following:
2. Manufacturers: Subject to compliance with requirements, provide products by one of the following:
3. Basis-of-Design Product: Subject to compliance with requirements, provide the product indicated on Drawings or a comparable product by one of the following:
 - a. Chicago Faucets.
 - b. Moen, Inc.
 - c. T & S Brass and Bronze Works, Inc.
4. Description: Include hot- and cold-water indicators; coordinate faucet inlets with supplies and fixture holes; coordinate outlet with spout and fixture receptor.
 - a. Body Material: Commercial, solid brass
 - b. Finish: Polished chrome plate
 - c. Maximum Flow Rate: 2.5 gpm (9.5 L/min.), unless otherwise indicated.
 - d. Mixing Valve: Two-lever handle.
 - e. Backflow Protection Device for Hose Outlet: Not required.
 - f. Backflow Protection Device for Side Spray: Not required
 - g. Centers: 4 inches (102 mm)
 - h. Mounting: Deck
 - i. Handle(s): Wrist blade, 4 inches (102 mm)
 - j. Inlet(s): NPS 1/2 (DN 15) female shank
 - k. Spout Type: Rigid gooseneck
 - l. Spout Outlet: Aerator
 - m. Vacuum Breaker: Not required
 - n. Operation: Compression, manual.
 - o. Drain: Grid

2.4 LAMINAR-FLOW FAUCET-SPOUT OUTLETS

A. Laminar-Flow Faucet-Spout Outlets:

1. Available Manufacturers: Subject to compliance with requirements, manufacturers offering products that may be incorporated into the Work include, but are not limited to, the following:
2. Manufacturers: Subject to compliance with requirements, provide products by one of the following:
3. Basis-of-Design Product: Subject to compliance with requirements, provide the product indicated on Drawings or a comparable product by one of the following:

- a. Chronomite Laboratories, Inc.
 - b. NEOPERL, Inc.
4. Description: Chrome-plated-brass faucet-spout outlet that produces non-aerating, laminar stream. Include male or female thread that mates with faucet outlet for attachment to faucets where indicated and flow-rate range that includes flow of faucet.

2.5 FLUSHOMETERS

A. Flushometers:

1. Available Manufacturers: Subject to compliance with requirements, manufacturers offering products that may be incorporated into the Work include, but are not limited to, the following:
2. Manufacturers: Subject to compliance with requirements, provide products by one of the following:
3. Basis-of-Design Product: Subject to compliance with requirements, provide the product indicated on Drawings or a comparable product by one of the following:
 - a. Zurn Plumbing Products Group; Commercial Brass Operation.
 - b. Sloan Company.
 - c. TOTO USA, Inc.
4. Description: Flushometer for urinal and water-closet-type fixture. Include brass body with corrosion-resistant internal components, non-hold-open feature, control stop with check valve, vacuum breaker, copper or brass tubing, and polished chrome-plated finish on exposed parts.
 - a. Internal Design: Diaphragm operation.
 - b. Style: Exposed
 - c. Inlet Size: [NPS 3/4 (DN 20)] [NPS 1 (DN 25)].
 - d. Trip Mechanism: Oscillating, lever-handle actuator
 - e. Consumption: 1.6 gal./flush (6.0 L/flush)
 - f. Tailpiece Size: NPS 1-1/2 (DN 40) length to top of bowl.

2.6 TOILET SEATS

A. Toilet Seats:

1. Available Manufacturers: Subject to compliance with requirements, manufacturers offering products that may be incorporated into the Work include, but are not limited to, the following:
2. Manufacturers: Subject to compliance with requirements, provide products by one of the following:

3. Basis-of-Design Product: Subject to compliance with requirements, provide the product indicated on Drawings or a comparable product by one of the following:
 - a. Bemis Manufacturing Company.
 - b. Church Seats.
 - c. Olsonite Corp.

4. Description: Toilet seat for water-closet-type fixture.
 - a. Material: Molded, solid plastic with antimicrobial agent
 - b. Configuration: Open front without cover.
 - c. Size: Elongated
 - d. Hinge Type: CK, check
 - e. Class: Heavy-duty commercial.
 - f. Color: White

2.7 PROTECTIVE SHIELDING GUARDS

A. Protective Shielding Pipe Covers:

1. Available Manufacturers: Subject to compliance with requirements, manufacturers offering products that may be incorporated into the Work include, but are not limited to, the following:
2. Manufacturers: Subject to compliance with requirements, provide products by one of the following:
 - a. Insul-Tect Products Co.; a Subsidiary of MVG Molded Products.
 - b. Plumberex Specialty Products Inc.
 - c. TRUEBRO, Inc.

3. Description: Manufactured plastic wraps for covering plumbing fixture hot- and cold-water supplies and trap and drain piping. Comply with Americans with Disabilities Act (ADA) requirements.

B. Protective Shielding Piping Enclosures:

1. Available Manufacturers: Subject to compliance with requirements, manufacturers offering products that may be incorporated into the Work include, but are not limited to, the following:
2. Manufacturers: Subject to compliance with requirements, provide products by one of the following:
 - a. TRUEBRO, Inc.

3. Description: Manufactured plastic enclosure for covering plumbing fixture hot- and cold-water supplies and trap and drain piping. Comply with ADA requirements.

2.8 FIXTURE SUPPORTS

- A. Available Manufacturers: Subject to compliance with requirements, manufacturers offering products that may be incorporated into the Work include, but are not limited to, the following:
- B. Manufacturers: Subject to compliance with requirements, provide products by one of the following:
 - 1. Josam Company.
 - 2. Smith, Jay R. Mfg. Co.
 - 3. Tyler Pipe; Wade Div.
 - 4. Zurn Plumbing Products Group; Specification Drainage Operation.
- C. Water-Closet Supports:
 - 1. Description: Combination carrier designed for accessible and standard mounting height of wall-mounting, water-closet-type fixture. Include single or double, vertical or horizontal, hub-and-spigot or hubless waste fitting as required for piping arrangement; faceplates; couplings with gaskets; feet; and fixture bolts and hardware matching fixture. Include additional extension coupling, faceplate, and feet for installation in wide pipe space. Carrier shall be rated at 500-750 lbs for bariatric use similar to J.R Smith 0220Y-M5A-XX
- D. Urinal Supports:
 - 1. Description: Type I, urinal carrier with fixture support plates and coupling with seal and fixture bolts and hardware matching fixture for wall-mounting, urinal-type fixture. Include steel uprights with feet.
 - 2. Accessible-Fixture Support: Include rectangular steel uprights.
- E. Lavatory Supports:
 - 1. Description: Type III, lavatory carrier with hanger plate and tie rod for wall-mounting, lavatory-type fixture. Include steel uprights with feet.
 - 2. Accessible-Fixture Support: Include rectangular steel uprights.
- F. Sink Supports:
 - 1. Description: Type I, sink carrier with exposed arms and tie rods for sink-type fixture. Include steel uprights with feet.

2.9 SHOWER RECEPTORS

- A. Shower Receptors:
 - 1. Available Manufacturers: Subject to compliance with requirements, manufacturers offering products that may be incorporated into the Work include, but are not limited to, the following:
 - a. Best Bath Systems

2. Basis-of-Design Product: Subject to compliance with requirements, provide the product indicated on Drawings or a comparable product by one of the following:
 - a. Crane Plumbing, L.L.C./Fiat Products.
 - b. American Standard Companies, Inc.
 - c. Stern-Williams Co., Inc.

3. Description: One piece gel coat/ fiber glass with integral ply wood backing and with the following factory installed accessories: Grab bar, folding seat, mixing valve, vacuum breaker and soap dish.
 - a. Type: Handicapped/wheelchair.
 - b. Size: As shown on the drawings.
 - c. Color: White.
 - d. Outlet: Drain with NPS 2 (DN 50) outlet.

2.10 WATER CLOSETS

A. Water Closets:

1. Available Manufacturers: Subject to compliance with requirements, manufacturers offering products that may be incorporated into the Work include, but are not limited to, the following:
2. Manufacturers: Subject to compliance with requirements, provide products by one of the following:
3. Basis-of-Design Product: Subject to compliance with requirements, provide the product indicated on Drawings or a comparable product by one of the following:
 - a. American Standard Companies, Inc.
 - b. Eljer.
 - c. Kohler Co.

4. Description Accessible, wall mounting, back-outlet, vitreous-china fixture designed for flushometer valve operation.
 - a. Style: One piece.
 - 1) Bowl Type: Elongated with siphon-jet design.
 - 2) Design Consumption: 1.6 gal./flush (6 L/flush)
 - 3) Trip Mechanism: Lever-handle actuator.
 - 4) Color: White.
 - b. Supply: 1 1/4" chrome-plated brass or copper with screwdriver stop.
 - c. Style: Flushometer valve.

- 1) Bowl Type: Elongated with siphon-jet design.
- 2) Design Consumption: 1.6 gal./flush (6 L/flush).
- 3) Color: White.

2.11 URINALS

A. Urinals:

1. Available Manufacturers: Subject to compliance with requirements, manufacturers offering products that may be incorporated into the Work include, but are not limited to, the following:
2. Manufacturers: Subject to compliance with requirements, provide products by one of the following:
3. Basis-of-Design Product: Subject to compliance with requirements, provide the product indicated on Drawings or a comparable product by one of the following:
 - a. American Standard Companies, Inc.
 - b. Eljer.
 - c. Kohler Co.
4. Description: Accessible, wall-mounting, back-outlet, vitreous-china fixture designed for flushometer valve operation.
 - a. Type: Siphon jet.
 - b. Strainer or Trapway: Integral cast strainer with integral trap.
 - c. Design Consumption: 1 gal./flush (3.8 L/flush).
 - d. Color: White.
 - e. Supply Spud Size: NPS 1-1/4 (DN 32).
 - f. Outlet Size: NPS 2 (DN 50)

2.12 LAVATORIES

A. Lavatories:

1. Available Manufacturers: Subject to compliance with requirements, manufacturers offering products that may be incorporated into the Work include, but are not limited to, the following:
2. Manufacturers: Subject to compliance with requirements, provide products by one of the following:
3. Basis-of-Design Product: Subject to compliance with requirements, provide the product indicated on Drawings or a comparable product by one of the following:
 - a. American Standard Companies, Inc.
 - b. Eljer.
4. Description: Accessible, wall-mounting, vitreous-china fixture.

- a. Type: Slab.
- b. Size: 20 by 18 inches (508 by 457 mm) rectangular.
- c. Faucet Hole Punching: Three holes, 4-inch (102-mm) centers.
- d. Faucet Hole Location: Top.
- e. Pedestal: Not required.
- f. Color: White.
- g. Faucet: Lavatory.
- h. Supplies: NPS 3/8 (DN 10) chrome-plated copper with stops.
- i. Drain: Grid.
 - 1) Location: Near back of bowl.
- j. Drain Piping: chrome-plated, cast-brass P-trap; NPS 1-1/2 (DN 40), thick tubular brass waste to wall; and wall escutcheon.
 - 1) Exception: Omit P-trap if hair interceptor is required.
- k. Hair Interceptor:
- l. Protective Shielding Guard(s):
- m. Fixture Support: Lavatory

2.13 COMMERCIAL SINKS

A. Commercial Sinks:

- 1. Available Manufacturers: Subject to compliance with requirements, manufacturers offering products that may be incorporated into the Work include, but are not limited to, the following:
- 2. Manufacturers: Subject to compliance with requirements, provide products by one of the following:
- 3. Basis-of-Design Product: Subject to compliance with requirements, provide the product indicated on Drawings or a comparable product by one of the following:
 - a. Elkay Manufacturing Co.
 - b. Just Manufacturing Company.
- 4. Description: One-compartment, counter-mounting, stainless-steel commercial sink with backsplash.
 - a. Overall Dimensions: 22" x 19" x 7 1/2"
 - b. Metal Thickness: 0.050 inch (1.3 mm).
 - c. Compartment:
 - 1) Dimensions: As shown on drawings
 - 2) Drain: Grid with NPS 2 (DN 50) tailpiece and twist drain
 - a) Location: Near back of compartment.

2.14 SERVICE SINKS

A. Service Sinks:

1. Available Manufacturers: Subject to compliance with requirements, manufacturers offering products that may be incorporated into the Work include, but are not limited to, the following:
2. Manufacturers: Subject to compliance with requirements, provide products by one of the following:
3. Basis-of-Design Product: Subject to compliance with requirements, provide the product indicated on Drawings or a comparable product by one of the following:
 - a. American Standard Companies, Inc.
 - b. Eljer.
 - c. Kohler Co.
4. Description: Trap-standard- and wall-mounting, enameled, cast-iron fixture with roll-rim vitreous-china fixture with two faucet holes in back and rim guard on front and sides.
 - a. Size: 24 by 20 inches (610 by 510 mm).
 - b. Size: 22 by 20 inches (560 by 510 mm).
 - c. Color: White.
 - d. Faucet: Sink.
 - e. Drain: Grid with NPS 3 (DN 80) outlet.
 - f. Trap Standard: NPS 3 (DN 80) enameled, cast iron with cleanout and floor flange.
 - g. Fixture Support: Sink.

PART 3 - EXECUTION

3.1 EXAMINATION

- A. Examine roughing-in of water supply and sanitary drainage and vent piping systems to verify actual locations of piping connections before plumbing fixture installation.
- B. Examine cabinets, counters, floors, and walls for suitable conditions where fixtures will be installed.
- C. Proceed with installation only after unsatisfactory conditions have been corrected.

3.2 INSTALLATION

- A. Assemble plumbing fixtures, trim, fittings, and other components according to manufacturers' written instructions.

- B. Install off-floor supports, affixed to building substrate, for wall-mounting fixtures.
 - 1. Use carrier supports with waste fitting and seal for back-outlet fixtures.
 - 2. Use carrier supports without waste fitting for fixtures with tubular waste piping.
 - 3. Use chair-type carrier supports with rectangular steel uprights for accessible fixtures.
- C. Install back-outlet, wall-mounting fixtures onto waste fitting seals and attach to supports.
- D. Install floor-mounting fixtures on closet flanges or other attachments to piping or building substrate.
- E. Install wall-mounting fixtures with tubular waste piping attached to supports.
- F. Install floor-mounting, back-outlet water closets attached to building floor substrate and wall bracket and onto waste fitting seals.
- G. Install counter-mounting fixtures in and attached to casework.
- H. Install fixtures level and plumb according to roughing-in drawings.
- I. Install water-supply piping with stop on each supply to each fixture to be connected to water distribution piping. Attach supplies to supports or substrate within pipe spaces behind fixtures. Install stops in locations where they can be easily reached for operation.
 - 1. Exception: Use ball, gate, or globe valves if supply stops are not specified with fixture. Valves are specified in Division 22 Section "General-Duty Valves for Plumbing Piping."
- J. Install trap and tubular waste piping on drain outlet of each fixture to be directly connected to sanitary drainage system.
- K. Install tubular waste piping on drain outlet of each fixture to be indirectly connected to drainage system.
- L. Install flushometer valves for accessible water closets and urinals with handle mounted on wide side of compartment. Install other actuators in locations that are easy for people with disabilities to reach.
- M. Install toilet seats on water closets.
- N. Install faucet-spout fittings with specified flow rates and patterns in faucet spouts if faucets are not available with required rates and patterns. Include adapters if required.
- O. Install water-supply flow-control fittings with specified flow rates in fixture supplies at stop valves.

- P. Install faucet flow-control fittings with specified flow rates and patterns in faucet spouts if faucets are not available with required rates and patterns. Include adapters if required.
- Q. Install shower flow-control fittings with specified maximum flow rates in shower arms.
- R. Install traps on fixture outlets.
 - 1. Exception: Omit trap on fixtures with integral traps.
 - 2. Exception: Omit trap on indirect wastes, unless otherwise indicated.
- S. Install disposer in outlet of each sink indicated to have disposer. Install switch where indicated or in wall adjacent to sink if location is not indicated.
- T. Install escutcheons at piping wall ceiling penetrations in exposed, finished locations and within cabinets and millwork. Use deep-pattern escutcheons if required to conceal protruding fittings. Escutcheons are specified in Division 22 Section "Common Work Results for Plumbing."
- U. Set shower receptors and service basins in leveling bed of cement grout. Grout is specified in Division 22 Section "Common Work Results for Plumbing."
- V. Seal joints between fixtures and walls, floors, and countertops using sanitary-type, one-part, mildew-resistant silicone sealant. Match sealant color to fixture color. Sealants are specified in Division 07 Section "Joint Sealants."

3.3 CONNECTIONS

- A. Piping installation requirements are specified in other Division 22 Sections. Drawings indicate general arrangement of piping, fittings, and specialties.
- B. Connect fixtures with water supplies, stops, and risers, and with traps, soil, waste, and vent piping. Use size fittings required to match fixtures.
- C. Ground equipment according to Division 26 Section "Grounding and Bonding for Electrical Systems."
- D. Connect wiring according to Division 26 Section "Low-Voltage Electrical Power Conductors and Cables."

3.4 FIELD QUALITY CONTROL

- A. Verify that installed plumbing fixtures are categories and types specified for locations where installed.
- B. Check that plumbing fixtures are complete with trim, faucets, fittings, and other specified components.

- C. Inspect installed plumbing fixtures for damage. Replace damaged fixtures and components.
- D. Test installed fixtures after water systems are pressurized for proper operation. Replace malfunctioning fixtures and components, then retest. Repeat procedure until units operate properly.
- E. Install fresh batteries in sensor-operated mechanisms.

3.5 ADJUSTING

- A. Operate and adjust faucets and controls. Replace damaged and malfunctioning fixtures, fittings, and controls.
- B. Operate and adjust disposers. Replace damaged and malfunctioning units.
- C. Adjust water pressure at faucets and flushometer valves to produce proper flow and stream.
- D. Replace washers and seals of leaking and dripping faucets and stops.
- E. Install fresh batteries in sensor-operated mechanisms.

3.6 CLEANING

- A. Clean fixtures, faucets, and other fittings with manufacturers' recommended cleaning methods and materials. Do the following:
 - 1. Remove faucet spouts and strainers, remove sediment and debris, and reinstall strainers and spouts.
 - 2. Remove sediment and debris from drains.
- B. After completing installation of exposed, factory-finished fixtures, faucets, and fittings, inspect exposed finishes and repair damaged finishes.

3.7 PROTECTION

- A. Provide protective covering for installed fixtures and fittings.
- B. Do not allow use of plumbing fixtures for temporary facilities unless approved in writing by Owner.

END OF SECTION

This page is intentionally left blank.

Section 22 62 19

VACUUM EQUIPMENT FOR HEALTHCARE FACILITIES

PART 1 - GENERAL

1.1 RELATED DOCUMENTS

- A. Drawings and general provisions of the Contract, including General and Supplementary Conditions and Division 01 Specification Sections, apply to this Section.
- B. Section 01 81 13 "Sustainable Design Requirements – LEED v4 for Building Design & Construction – New Construction" for sustainable design requirements and detailed sustainable design submittal requirements.
- C. Section 01 74 19 "Construction and Demolition Waste Management and Disposal" for disposal of construction, demolition and packaging waste disposal requirements.

1.2 SUMMARY

- A. Section Includes:
 - 1. Package, claw type vacuum pumps.
 - 2. Medical vacuum equipment alarm systems.
 - 3. Computer interface cabinets.
- B. Sustainable Building Requirements:
 - 1. The Owner requires the Contractor to implement practices and procedures to meet the project's environmental performance goals, which include achieving LEED version 4 **Certified** level Certification. Specific project goals that may impact this area of work include: use of recycled-content materials; use of locally-manufactured materials; use of low-emitting materials; construction waste recycling; and the implementation of a construction indoor air quality management plan. The Contractor shall ensure that the requirements related to these goals, as defined in the Articles below, are implemented to the fullest extent. Substitutions, or other changes to the work proposed by the Contractor or their Subcontractors, shall not be allowed if such changes compromise the aforementioned environmental goals and LEED certification.

1.3 DEFINITIONS

- A. Actual Air: Air delivered at vacuum producer inlet. Flow rate is air measured in expanded cfm (expanded L/s).
- B. HVE: High-volume oral evacuation for dental applications in healthcare facilities.
- C. Laboratory Vacuum Equipment: Equipment and accessories for nonmedical laboratory facilities.

- D. Low Voltage: As defined in NFPA 70 for circuits and equipment operating at less than 50 V or for remote-control, signaling power-limited circuits.
- E. Medical vacuum equipment includes medical vacuum, WAGD evacuation and healthcare laboratory vacuum equipment and accessories for healthcare facilities.
- F. Standard Air: Free air at 68 deg F (20 deg C) and 1 atmosphere (29.92 in. Hg) before compression or expansion and measured in scfm (standard L/s).
- G. WAGD Evacuation: Waste anesthetic gas disposal for medical-surgical applications in healthcare facilities.

1.4 PERFORMANCE REQUIREMENTS

- A. Delegated Design: Design vacuum equipment mounting, including comprehensive engineering analysis by a qualified professional engineer, using performance requirements and design criteria indicated.
- B. Seismic Performance: Vacuum equipment shall withstand the effects of earthquake motions determined according to SEI/ASCE 7.
 - 1. The term "withstand" means "the unit will remain in place without separation of any parts from the device when subjected to the seismic forces specified and the unit will be fully operational after the seismic event."

1.5 SUBMITTALS

- A. Product Data: For each type of product indicated. Include rated capacities, operating characteristics, electrical characteristics, and furnished specialties and accessories.
 - 1. Wiring Diagrams: For power, signal, and control wiring.
- B. Delegated-Design Submittal: For vacuum-producing equipment mounting indicated to comply with performance requirements and design criteria, including analysis data signed and sealed by the qualified professional engineer responsible for their preparation.
 - 1. Detail fabrication and assembly of supports.
 - 2. Design Calculations: Calculate requirements for selecting vibration isolators and seismic restraints and for designing vibration isolation bases.
- C. Qualification Data: For qualified testing agency.
- D. Seismic Qualification Certificates: For vacuum producers, accessories, and components, from manufacturer.
 - 1. Basis for Certification: Indicate whether withstand certification is based on actual test of assembled components or on calculation.
 - 2. Dimensioned Outline Drawings of Equipment Unit: Identify center of gravity and locate and describe mounting and anchorage provisions.

3. Detailed description of equipment anchorage devices on which the certification is based and their installation requirements.

E. Field quality-control reports.

F. Operation and Maintenance Data: For vacuum equipment to include in operation and maintenance manuals.

1.6 QUALITY ASSURANCE

A. Installer Qualifications:

1. Laboratory Vacuum System Equipment for Nonmedical Laboratory Facilities: An employer of workers trained and approved by manufacturer.

2. Medical Vacuum System Equipment for Healthcare Facilities: Qualify installers according to ASSE 6010.

B. Testing Agency Qualifications: An independent testing agency, with the experience and capability to conduct the vacuum equipment testing indicated, that is an NRTL, and that is acceptable to authorities having jurisdiction.

1. Qualify testing personnel according to ASSE 6020 for inspectors and ASSE 6030 for verifiers.

C. Electrical Components, Devices, and Accessories: Listed and labeled as defined in NFPA 70, by a qualified testing agency, and marked for intended location and application.

D. ASME Compliance: Fabricate and label receivers to comply with ASME Boiler and Pressure Vessel Code.

E. Comply with NFPA 99, "Health Care Facilities," for vacuum equipment and accessories for medical vacuum systems.

F. Comply with UL 544, "Medical and Dental Equipment," for medical vacuum equipment.

1.7 COORDINATION

A. Coordinate sizes and locations of concrete bases with actual equipment provided.

1.8 EXTRA MATERIALS

A. Furnish extra materials that match products installed and that are packaged with protective covering for storage and identified with labels describing contents.

1. Belts: Two for each belt-driven vacuum producer.

PART 2 - PRODUCTS

2.1 GENERAL REQUIREMENTS FOR PACKAGED VACUUM PUMPS

- A. Description: Factory-assembled, -wired, -piped, and -tested; electric-motor-driven; air-cooled; continuous-duty vacuum pumps and receivers.
- B. Control Panels: Automatic control station with load control and protection functions. Comply with NEMA ICS 2 and UL 508.
 - 1. Enclosure: NEMA ICS 6, Type 12 control panel unless otherwise indicated.
 - 2. Motor Controllers: Full-voltage, combination-magnetic type with undervoltage release feature and motor-circuit-protector-type disconnecting means and short-circuit protective device.
 - 3. Control Voltage: 120-V ac or less, using integral control power transformer.
 - 4. Motor Overload Protection: Overload relay in each phase.
 - 5. Starting Devices: Hand-off-automatic selector switch in cover of control panel, plus pilot device for automatic control.
 - 6. Automatic control switches to sequence lead-lag vacuum pumps for multiplex vacuum pumps.
 - 7. Instrumentation: Include vacuum pump inlet and receiver vacuum gages, hour meter, vacuum pump discharge-air and coolant temperature gages, and control transformer.
 - 8. Alarm Signal Device: For connection to alarm system to indicate when backup vacuum pump is operating.
- C. Receivers: Steel tank constructed according to ASME Boiler and Pressure Vessel Code, Section VIII, Division 1; bearing appropriate code symbols.
 - 1. Interior Finish: Corrosion-resistant coating.
 - 2. Accessories: Include vacuum relief valve, vacuum gage, and drain.
- D. Mounting Frame: Fabricate base and attachment to pressure vessel with reinforcement strong enough to resist packaged equipment movement during a seismic event when base is anchored to building structure.

2.2 CLAW TYPE VACUUM PUMPS

- A. Furnish and install per plans and specifications one (1) BeaconMedaes Model 7D-120V-DV Oil-less claw medical vacuum system complete with Variable Speed Drive, fully compliant with the latest edition of NFPA 99. The package is to consist of two (2) 7.4 HP oil-less rotary claw vacuum pumps, each rated for 65 SCFM @ 19" HgV, complete with a duplex control and 120 gallon ASME coded receiver tank with a 3-valve by-pass system to allow for draining of the receiver without interrupting the vacuum service. A manual drain is to be provided on the receiver. The package is to be furnished as a single point connection system and completely tested prior to shipment.
- B. Each pump is to be direct driven, non-contacting claw type, capable of operating at 24" HgV continuous duty. The pumping chamber is to be oil-free. The pump must be completely air-cooled with no water requirements. The pump is to have an inlet

air filter and be equipped with a vacuum relief valve, check valve to prevent backflow through off-cycle units, flexible connector, isolation valve, high discharge temperature switch, high inlet vacuum switch, oil drain valve, oil sight glass, and exhaust muffler at each pump location.

- C. The motors are to be continuous duty, NEMA rated, C-face, TEFC, 3450 RPM with a 1.15 service factor suitable for 208V or 230/460V-3PH-60HZ, 3-phase electrical service.
- D. Each vacuum pump is to have a factory piped intake with integral flex connector, isolation valve, and check valve. The vacuum receiver tank is to be a 120 gallon ASME code stamped and rated for a minimum of 150 psig design pressure. All components are to be pre-piped and wired to constitute a single point connection system.
- E. The duplex control system is to be NEMA 12 and U.L. labeled. The control system shall have an HMI (Human Machine Interface) touch screen control, single variable speed drive, automatic lead/lag sequencing, single external operator with circuit breaker disconnects, full voltage motor starters and VSD contactors, overload protection, 24V control circuit and hand-off-auto principle with provisions for simultaneous operation if required. Automatic activation of reserve unit if required, will activate an audible alarm as well as a visual alarm on the HMI.
- F. The HMI must display service alerts, run hours for each vacuum pump, system status, system vacuum level, high discharge air temperature and high inlet vacuum shutdown. A complete alarm and service history must be available on the HMI.
- G. System must be warranted to be free of defects in material and workmanship under normal use for a period not to exceed thirty (30) months from date of shipment, or twenty-four (24) months from date of start-up. Start-up and owner's training is to be provided.

2.3 MEDICAL VACUUM EQUIPMENT ALARM SYSTEMS

- A. Basis-of-Design Product: Subject to compliance with requirements, provide product indicated on Drawings comparable product by one of the following:
 - 1. Allied Healthcare Products, Inc.; Chemetron Div.
 - 2. Amico Corporation.
 - 3. BeaconMedaes.
- B. General Requirements for Medical Vacuum Equipment Alarm System: Compatible alarm panels, remote sensing devices, and other related components as required by NFPA 99 for Level 1 alarm systems. Refer to Division 22 Section "Vacuum Piping for Laboratory and Healthcare Facilities" for medical vacuum piping and alarm systems. Power wiring is specified in Division 26 Sections.
- C. Components: Designed for continuous service and to operate on power supplied from 120-V ac power source to alarm panels and with connections for low-voltage wiring to remote sensing devices. Include step-down transformers if required.
- D. Vacuum Switches or Transducer Sensors: Continuous equipment monitoring with electrical connections for alarm system.

1. Vacuum Switches: 0- to 30-in. Hg (0- to 101-kPa) vacuum operating range.
- E. General Requirements for Medical Vacuum Equipment Alarm Panels: Factory wired with audible and color-coded visible signals to indicate specified functions.
 1. Mounting: Recessed installation.
 2. Enclosures: Fabricated from minimum 0.047-inch- (1.2-mm-) thick steel or minimum 0.05-inch- (1.27-mm-) thick aluminum, with knockouts for electrical and piping connections.
- F. Local and Master Alarm Panels: Separate trouble alarm signals and pressure gages to indicate function of medical vacuum equipment when the following conditions exist:
 1. Medical Vacuum Equipment: Drops below 12-in. Hg (40.6-kPa) vacuum, backup vacuum producer is in operation, and high water level is in receiver.

2.4 MOTORS

- A. Comply with NEMA designation, temperature rating, service factor, enclosure type, and efficiency requirements for motors specified in Division 22 Section "Common Motor Requirements for Plumbing Equipment."
 1. Motor Sizes: Minimum size as indicated. If not indicated, large enough so driven load will not require motor to operate in service factor range above 1.0.
 2. Controllers, Electrical Devices, and Wiring: Comply with requirements for electrical devices and connections specified in Division 26 Sections.

2.5 COMPUTER INTERFACE CABINET

- A. Description:
 1. Wall mounting.
 2. Welded steel with white-enamel finish.
 3. Gasketed door.
 4. Grounding device.
 5. Factory-installed signal circuit boards.
 6. Power transformer.
 7. Circuit breaker.
 8. Wiring terminal board.
 9. Internal wiring capable of interfacing 20 alarm signals.

PART 3 - EXECUTION

3.1 PREPARATION

- A. Clean vacuum equipment, accessories, and components that have not been cleaned for oxygen service and sealed or that are furnished unsuitable for medical vacuum applications, according to CGA G4.1, "Cleaning Equipment for Oxygen Service."

3.2 VACUUM EQUIPMENT INSTALLATION

- A. Install vacuum equipment for healthcare facilities according to ASSE 6010 and NFPA 99.
- B. Equipment Mounting: Install vacuum producer on concrete bases using elastomeric pads. Comply with requirements in Division 03 Section "Cast-in-Place Concrete." Comply with requirements for vibration isolation devices specified in Division 22 Section "Vibration and Seismic Controls for Plumbing Piping and Equipment."
 - 1. Minimum Deflection: 1/4 inch (6 mm).
 - 2. Install dowel rods to connect concrete base to concrete floor. Unless otherwise indicated, install dowel rods on 18-inch (450-mm) centers around the full perimeter of concrete base.
 - 3. For supported equipment, install epoxy-coated anchor bolts that extend through concrete base and anchor into structural concrete floor.
 - 4. Place and secure anchorage devices. Use setting drawings, templates, diagrams, instructions, and directions furnished with items to be embedded.
 - 5. Install anchor bolts to elevations required for proper attachment to supported equipment.
- C. Install vacuum equipment anchored to substrate.
- D. Orient equipment so controls and devices are accessible for servicing.
- E. Maintain manufacturer's recommended clearances for service and maintenance.
- F. Install the following devices on vacuum equipment:
 - 1. Thermometer, Vacuum Gage, and Pressure Relief Valve: Install on each vacuum pump receiver.
 - 2. Drain Valves: Install on receivers. Discharge receiver condensate over nearest floor drain. Discharge separator and evacuation fluids by direct connection into sanitary waste piping system.

3.3 MEDICAL VACUUM EQUIPMENT ALARM SYSTEM INSTALLATION

- A. Alarm panels for medical vacuum equipment may be combined in single panels with medical air equipment and medical gas piping systems.
- B. Install medical vacuum equipment alarm system components in locations required by and according to NFPA 99.
- C. Install medical vacuum equipment local and master alarm panels where indicated.

3.4 COMPUTER INTERFACE CABINET INSTALLATION

- A. Install computer interface cabinet with connection to medical vacuum piping alarm system and to facility computer.

3.5 CONNECTIONS

- A. Comply with requirements for water-supply piping specified in Division 22 Section "Domestic Water Piping." Drawings indicate general arrangement of piping, fittings, and specialties.
- B. Comply with requirements for drain piping specified in Division 22 Section "Sanitary Waste and Vent Piping." Drawings indicate general arrangement of piping, fittings, and specialties.
- C. Comply with requirements for vacuum piping specified in Division 22 Section "Vacuum Piping for Laboratory and Healthcare Facilities." Drawings indicate general arrangement of piping, fittings, and specialties.
- D. Install piping adjacent to equipment to allow service and maintenance.
- E. Connect vacuum piping to vacuum equipment, accessories, and specialties with shutoff valve and union or flanged connection.
- F. Connect water supply to vacuum equipment that requires water. Include backflow preventer. Backflow preventers are specified in Division 22 Section "Domestic Water Piping Specialties."

3.6 IDENTIFICATION

- A. Identify nonmedical laboratory vacuum equipment system components. Comply with requirements for identification specified in Division 22 Section "Identification for Plumbing Piping and Equipment."
- B. Identify medical vacuum equipment system components. Comply with requirements for identification specified in Division 22 Section "Identification for Plumbing Piping and Equipment." and with NFPA 99.

3.7 FIELD QUALITY CONTROL FOR HEALTHCARE-FACILITY MEDICAL VACUUM EQUIPMENT

- A. Testing Agency: Engage a qualified testing agency to perform tests and inspections.
- B. Manufacturer's Field Service: Engage a factory-authorized service representative to inspect, test, and adjust components, assemblies, and equipment installations, including connections.
- C. Perform tests and inspections.
 - 1. Manufacturer's Field Service: Engage a factory-authorized service representative to inspect components, assemblies, and equipment installations, including connections, and to assist in testing.
- D. Tests and Inspections:
 - 1. Medical Vacuum Equipment Testing Coordination: Perform tests, inspections, verifications, and certification of medical vacuum equipment concurrently with

tests, inspections, and certification of medical compressed-air equipment, medical compressed-air piping, medical vacuum piping and medical gas piping systems.

2. Preparation: Perform medical vacuum equipment tests according to requirements in NFPA 99 for the following:
 - a. System operation test.
3. Equipment Verification: Comply with requirements in ASSE 6020, ASSE 6030, and NFPA 99 for verification of medical vacuum equipment.
4. Replace damaged and malfunctioning controls and equipment.
5. Testing Certification: Certify that specified tests, inspections, and procedures have been performed and certify report results. Include the following:
 - a. Inspections performed.
 - b. Procedures and materials used.
 - c. Test methods used.
 - d. Results of tests.

- E. Components will be considered defective if they do not pass tests and inspections.
- F. Prepare test and inspection reports.

3.8 STARTUP SERVICE

- A. Perform startup service.
 1. Complete installation and startup checks according to manufacturer's written instructions.
 2. Check for lubricating oil in lubricated-type equipment.
 3. Check belt drives for proper tension.
 4. Verify that vacuum producer outlet piping is clear.
 5. Check for equipment vibration-control supports and flexible pipe connectors and verify that equipment is properly attached to substrate.
 6. Check safety valves for correct settings.
 7. Check for proper seismic restraints.
 8. Drain receiver tank(s).
 9. Operational Test: After electrical circuitry has been energized, start units to confirm proper motor rotation and unit operation.
 10. Test and adjust controls and safeties.
- B. Verify that vacuum equipment is installed and connected according to the Contract Documents.
- C. Verify that electrical wiring installation complies with manufacturer's submittal and written installation requirements in Division 26 Sections.
- D. Prepare written report documenting testing procedures and results.

3.9 DEMONSTRATION

- A. Engage a factory-authorized service representative to train Owner's maintenance personnel to adjust, operate, and maintain vacuum producers.

END OF SECTION

Section 22 63 13

GAS PIPING FOR LABORATORY AND HEALTHCARE FACILITIES

PART 1 - GENERAL

1.1 RELATED DOCUMENTS

- A. Drawings and general provisions of the Contract, including General and Supplementary Conditions and Division 01 Specification Sections, apply to this Section.
- B. Section 01 81 13 "Sustainable Design Requirements – LEED v4 for Building Design & Construction – New Construction" for sustainable design requirements and detailed sustainable design submittal requirements.
- C. Section 01 74 19 "Construction and Demolition Waste Management and Disposal" for disposal of construction, demolition and packaging waste disposal requirements.

1.2 SUMMARY

- A. This Section includes the following:
 - 1. Nitrogen piping and specialties designated "medical nitrogen" operating at 160 to 185 psig (1100 to 1275 kPa).
 - 2. Nitrous oxide piping and specialties designated "medical nitrous oxide" operating at 50 to 55 psig (345 to 380 kPa).
 - 3. Oxygen piping and specialties designated "medical oxygen" operating at 50 to 55 psig (345 to 380 kPa).
- B. Owner-Furnished Material:
 - 1. Ceiling columns.
 - 2. Owner will furnish gases for medical gas concentration testing specified in this Section.
 - 3. Supply of gases in cylinders or containers as appropriate for manifolds.
 - 4. Initial supply of liquid oxygen.
 - 5. Bulk cryogenic systems. Coordinate all plumbing and alarm connections to the bulk gas source, source start-up and system testing, providing the owner with systems ready for use.
- C. Related Sections include the following
 - 1. Division 22 Section "Compressed-Air Piping for Laboratory and Healthcare Facilities" for compressed-air piping systems for laboratory and healthcare facilities.
 - 2. Division 22 Section "Vacuum Piping for Laboratory and Healthcare Facilities" for vacuum piping systems for laboratory and healthcare facilities.

D. Sustainable Building Requirements:

1. The Owner requires the Contractor to implement practices and procedures to meet the project's environmental performance goals, which include achieving LEED version 4 **Certified** level Certification. Specific project goals that may impact this area of work include: use of recycled-content materials; use of locally-manufactured materials; use of low-emitting materials; construction waste recycling; and the implementation of a construction indoor air quality management plan. The Contractor shall ensure that the requirements related to these goals, as defined in the Articles below, are implemented to the fullest extent. Substitutions, or other changes to the work proposed by the Contractor or their Subcontractors, shall not be allowed if such changes compromise the aforementioned environmental goals and LEED certification.

1.3 DEFINITIONS

- A. CR: Chlorosulfonated polyethylene synthetic rubber.
- B. D.I.S.S.: Diameter-index safety system.
- C. Low Voltage: As defined in NFPA 70 for circuits and equipment operating at less than 50 V or for remote-control, signaling power-limited circuits.
- D. Medical gas piping systems include medical carbon dioxide, medical nitrogen, medical nitrous oxide and medical oxygen nonflammable gas for healthcare facility patient care or for healthcare laboratory applications.
- E. Specialty Gas: Gas, other than medical gas, for nonmedical laboratory facility applications.

1.4 PERFORMANCE REQUIREMENTS

- A. Seismic Performance: Gas manifolds and bulk gas storage tanks and piping shall withstand the effects of earthquake motions determined according to SEI/ASCE 7.
 1. The term "withstand" means "the unit will remain in place without separation of any parts from the device when subjected to the seismic forces specified."

1.5 SUBMITTALS

- A. Product Data: For the following:
 1. Tubes and fittings.
 2. Valves and valve boxes.
 3. Medical gas service connections.
 4. Electrical service connections.
 5. Medical nitrogen pressure control panels.
 6. Ceiling columns. Include integral service connections.
 7. Gas manifolds.
 8. Bulk gas storage tanks. Include rated capacities and operating weights.

9. Medical gas alarm system components.
 10. Gas cylinder storage racks.
 11. Buried and insulated oxygen piping.
- B. Shop Drawings: Diagram power, signal, and control wiring.
- C. Piping Material Certification: Signed by Installer certifying that medical gas piping materials comply with NFPA 99 requirements.
- D. Qualification Data: For Installer.
- E. Brazing certificates.
- F. Manufacturer Seismic Qualification Certification: Submit certification that gas manifolds and bulk gas storage tanks, accessories, and components will withstand seismic forces defined in Division 22 Section "Vibration and Seismic Controls for Plumbing Piping and Equipment." Include the following:
1. Basis for Certification: Indicate whether withstand certification is based on actual test of assembled components or on calculation.
- G. Certificates of Shop Inspection and Data Report for Bulk Gas Storage Tanks: As required by ASME Boiler and Pressure Vessel Code.
- H. Field quality-control test reports.
- I. Operation and Maintenance Data: For medical gas piping specialties to include in emergency, operation, and maintenance manuals.

1.6 QUALITY ASSURANCE

- A. Installer Qualifications:
1. Medical Gas Piping Systems for Healthcare Facilities: Qualify installers according to ASSE Standard #6010 for installers.
 2. All materials used shall be new and of the best grade and quality obtainable and workmanship shall be first class in every respect. Contractor shall be responsible for compliance with all local, state or federal codes.
 3. Provide all elements and accessories required for complete system per NFPA 99 most recent edition.
 4. Contractor shall make all necessary connections to owner furnished equipment.
 5. Install all piping as shown on drawings, as described herein and as described in section 1050, basic materials and methods, using methods of fabrication, grading, testing, repairing, cleaning and other procedures as described.
 6. Electrical power wiring for vacuum pumps, medical air compressors, WAGD producers, ceiling columns, alarms and modular accessories associated with the system shall be part of the electrical contract. Any equipment supplied by this contractor that require additional electrical services shall be the responsibility of this contractor to supply these services.

7. Perform installer pressure testing, cross connection testing and final testing per NFPA 99 most recent edition and using procedures as specified.
 - B. Testing Agency Qualifications: An independent testing agency, with the experience and capability to conduct the medical gas piping testing indicated, that is an NRTL as defined by OSHA in 29 CFR 1910.7, and that is acceptable to authorities having jurisdiction.
 1. Qualify testing personnel according to ASSE Standard #6020 for inspectors and ASSE Standard #6030 for verifiers.
 - C. Brazing: Qualify processes and operators according to ASME Boiler and Pressure Vessel Code: Section IX, "Welding and Brazing Qualifications"; or AWS B2.2, "Standard for Brazing Procedure and Performance Qualification."
 - D. Electrical Components, Devices, and Accessories: Listed and labeled as defined in NFPA 70, Article 100, by a testing agency acceptable to authorities having jurisdiction, and marked for intended use.
 - E. ASME Compliance: Fabricate and label bulk medical gas storage tanks to comply with ASME Boiler and Pressure Vessel Code: Section VIII, Division 1.
 - F. NFPA Compliance:
 1. Comply with NFPA 50, "Bulk Oxygen Systems at Consumer Sites," for bulk oxygen storage tanks.
 2. Comply with NFPA 99, "Health Care Facilities," for medical gas piping system materials and installation.
 - G. CGA Compliance: Comply with CGA G-8.1, "Nitrous Oxide Systems at Consumer Sites," for bulk nitrous oxide storage tanks.
 - H. UL Compliance:
 1. Comply with UL 498, "Attachment Plugs and Receptacles," for electrical service connections.
 2. Comply with UL 544, "Medical and Dental Equipment," for medical gas specialties.
- 1.7 COORDINATION
- A. Coordinate size and location of concrete bases. Cast anchor-bolt inserts into bases. Concrete, reinforcement, and formwork requirements are specified in Division 03.
 - B. Coordinate medical gas service connections with other service connections. Compressed-air service connections are specified in Division 22 Sections "Compressed-Air Piping for Laboratory and Healthcare Facilities" and "Vacuum Piping for Laboratory and Healthcare Facilities."

- C. Work with metal and stud partition installer and/or mason to ensure anchors, sleeves and similar items are provided in sufficient time to avoid delays, chases and openings are properly sized and prepared.
- D. Medical gas contractor shall supply and install the master alarm system and area alarm systems, including the signal wiring. The electrical contractor shall provide power wiring to each alarm panel. The medical gas contractor is responsible for proper termination, testing and marking of alarm panels. Termination shall be done under supervision of manufacturer of alarm panels.

1.8 EXTRA MATERIALS

- A. Furnish extra materials described below that match products installed and that are packaged with protective covering for storage and identified with labels describing contents.
 - 1. Quick-Coupler Service Connections: Furnish complete noninterchangeable medical gas pressure outlets and suction inlets.
 - a. Medical Air: Equal to 10 percent of amount installed.
 - b. Medical Carbon Dioxide: Equal to 10 percent of amount installed.
 - c. Medical Nitrous Oxide: Equal to 10 percent of amount installed.
 - d. Medical Oxygen: Equal to 10 percent of amount installed.
 - e. Medical Vacuum: Equal to 10 percent of amount installed.
 - f. WAGD Evacuation: Equal to 10 percent of amount installed.
 - 2. D.I.S.S. Service Connections: Furnish complete noninterchangeable medical gas pressure outlets and suction inlets complying with CGA V-5.
 - a. Medical Air D.I.S.S. No. 1160: Equal to 10 percent of amount installed.
 - b. Medical Carbon Dioxide D.I.S.S. No. 1080: Equal to 10 percent of amount installed.
 - c. Medical Nitrogen D.I.S.S. No. 1120: Equal to 10 percent of amount installed.
 - d. Medical Nitrous Oxide D.I.S.S. No. 1040: Equal to 10 percent of amount installed.
 - e. Medical Oxygen D.I.S.S. No. 1240: Equal to 10 percent of amount installed.
 - f. Medical Vacuum D.I.S.S. No. 1220: Equal to 10 percent of amount installed.
 - g. WAGD Evacuation D.I.S.S. No. 2220: Equal to 10 percent of amount installed.
 - 3. Vacuum Bottle Brackets: Equal to 10 percent of amount installed.

PART 2 - PRODUCTS

2.1 PIPES, TUBES, AND FITTINGS

- A. Copper Medical Gas Tube: ASTM B 819, Types K and L, seamless, drawn temper that has been manufacturer cleaned, purged, and sealed for medical gas service or according to CGA G-4.1 for oxygen service. Include standard color marking "OXY," "MED," "OXY/MED," "OXY/ACR," or "ACR/MED" in green for Type K tube and blue for Type L tube.
1. General Requirements for Copper Fittings: Manufacturer cleaned, purged, and bagged for oxygen service according to CGA G-4.1.
 2. Wrought-Copper Fittings: ASME B16.22, solder-joint pressure type or MSS SP-73, with dimensions for brazed joints.
 3. Copper Unions: ASME B16.22 or MSS SP-123, wrought copper or cast-copper alloy.
 4. Press-Type Fittings:
 - a. Available Manufacturers: Subject to compliance with requirements, manufacturers offering products that may be incorporated into the Work include, but are not limited to, the following:
 - b. Manufacturers: Subject to compliance with requirements, provide products by one of the following:
 - 1) Viega; Plumbing and Heating Systems.
 - c. NPS 2 (DN 50) and Smaller: Wrought-copper fitting with EPDM O-ring seal in each end.
 - d. NPS 2-1/2 to NPS 4 (DN 65 to DN 100): Bronze fitting with stainless-steel grip ring and EPDM O-ring seal in each end.
 5. Memory-Metal Couplings: Cryogenic compression fitting made of ASTM F 2063, nickel-titanium, shape-memory-alloy, and that has been manufacturer cleaned, purged, and sealed for oxygen service according to CGA G-4.1.
 - a. Available Manufacturers: Subject to compliance with requirements, manufacturers offering products that may be incorporated into the Work include, but are not limited to, the following:
 - b. Manufacturers: Subject to compliance with requirements, provide products by one of the following:
 - 1) Smart Technology, Inc.

2.2 JOINING MATERIALS

- A. Brazing Filler Metals: AWS A5.8/A5.8M, BCuP Series, copper-phosphorus alloys.
- B. Threaded-Joint Tape: PTFE.

2.3 Buried Oxygen

- A. All underground oxygen lines with design temperatures up to 250 degrees shall be XTRU-THERM as manufactured by PERMA-PIPE. All straight sections, fittings, anchors and other accessories shall be factory fabricated, insulated and jacketed. The piping system layout shall be analyzed by the piping system manufacturer to determine the stresses and displacements of the service pipe. The piping system design and manufacturer shall be in strict conformance with ASME B31.1, latest edition. Installation of the piping system shall be in accordance with the manufacturers instructions. Factory trained field technical assistance shall be provided for critical periods of installation, unloading, field joint instruction and testing.
- B. The service pipe shall be hard drawn seamless copper ASTM C-819 Type L. Tubes, fittings and other components in medical gas systems shall be cleaned and capped in accordance with CGA-G-4.1. Where possible, straight sections shall be supplied in 20-foot random lengths with piping exposed at each end for field joint fabrication.
- C. Elbows, tees, reducers, anchors, field joints, and end seals shall be designed and factory fabricated to prevent the ingress of moisture into the system.
- D. The service pipe insulation shall be polyurethane foam with 2.0 lbs/ft² minimum density, 90% minimum closed cell content and initial thermal conductivity of 0.16 Btu in/hr FT² ° F. The insulation shall completely fill the annular space between the service pipe and jacket shall be bonded to both. Systems using open cell insulation of a non-bonded design shall not be allowed. Insulation for piping 1" to 4" shall be 1 ½".
- E. The outer protective insulation jacket shall be seamless high-density polyethylene (HDPE) in accordance with ASTM D1248, type 3, Class C. PVC or tape materials are not allowed. The minimum thickness of the HDPE jacket shall be 0.125".
- F. All fittings shall be factory prefabricated and pre-insulated. Straight tangent lengths shall be added to all ends so that all field joints are at straight sections of pipe. Elbow jackets shall be molded HDPE. Tee jackets shall be extrusion welded or butt fusion welded HDPE. Gluing, taping or hot air welding shall not be allowed.
- G. The service pipe shall be hydrostatically tested to 15- psig or 1 ½ times the design pressures whichever is greater. Insulation shall then be poured in place into the field joint area. All field-applied insulation shall be placed only in straight sections of pipe. Field insulation of fittings is not acceptable. The installed shall seal with field joint area with a heat shrinkable adhesive backed sleeve. Backfilling shall not begin until the heat shrink sleeve has cooled. All insulation and jacketing materials for the field joint shall be furnished by PERMA-PIPE.
- H. A 4" layer of sand or fine gravel shall be placed and tamped in the trench to provide a uniform bedding for the pipe. The entire trench width shall be evenly backfilled with a similar material as the bedding in 6" compacted layers to a minimum height of 6" above the top of the insulated pipe. The remaining trench shall be evenly and continuously backfilled and compacted in uniform layers with suitable excavated soil.

2.4 VALVES

- A. General Requirements for Valves: Manufacturer cleaned, purged, and bagged according to CGA G-4.1 for oxygen service.
- B. Ball Valves: MSS SP-110, 3-piece body, brass or bronze.
 - 1. Available Manufacturers: Subject to compliance with requirements, manufacturers offering products that may be incorporated into the Work include, but are not limited to, the following:
 - 2. Manufacturers: Subject to compliance with requirements, provide products by one of the following:
 - 3. Basis-of-Design Product: Subject to compliance with requirements, provide a comparable product by one of the following:
 - a. BeaconMedaes.
 - b. Conbraco Industries, Inc.
 - c. NIBCO INC.
 - 4. Pressure Rating: 300 psig (2070 kPa) minimum.
 - 5. Ball: Full-port, chrome-plated brass.
 - 6. Seats: PTFE or TFE.
 - 7. Handle: Lever type with locking device.
 - 8. Stem: Blowout proof with PTFE or TFE seal.
 - 9. Ends: Manufacturer-installed ASTM B 819, copper-tube extensions.
- C. Check Valves: In-line pattern, bronze.
 - 1. Available Manufacturers: Subject to compliance with requirements, manufacturers offering products that may be incorporated into the Work include, but are not limited to, the following:
 - 2. Manufacturers: Subject to compliance with requirements, provide products by one of the following:
 - 3. Basis-of-Design Product: Subject to compliance with requirements, provide the product indicated on Drawings a comparable product by one of the following:
 - a. Allied Healthcare Products, Inc.; Chemetron Div.
 - b. BeaconMedaes.
 - c. Conbraco Industries, Inc.
 - 4. Pressure Rating: 300 psig (2070 kPa) minimum.
 - 5. Operation: Spring loaded.
 - 6. Ends: Manufacturer-installed ASTM B 819, copper-tube extensions.
- D. Zone Valves: MSS SP-110, 3-piece-body, brass or bronze ball valve with gage.
 - 1. Available Manufacturers: Subject to compliance with requirements, manufacturers offering products that may be incorporated into the Work include, but are not limited to, the following:

2. Manufacturers: Subject to compliance with requirements, provide products by one of the following:
 3. Basis-of-Design Product: Subject to compliance with requirements, provide the product indicated on Drawings a comparable product by one of the following:
 - a. Allied Healthcare Products, Inc.; Chemetron Div.
 - b. Amico Corporation.
 - c. BeaconMedaes.
 4. Pressure Rating: 300 psig (2070 kPa) minimum.
 5. Ball: Full-port, chrome-plated brass.
 6. Seats: PTFE or TFE.
 7. Handle: Lever type with locking device.
 8. Stem: Blowout proof with PTFE or TFE seal.
 9. Ends: Manufacturer-installed ASTM B 819, copper-tube extensions.
 10. Pressure Gage: Manufacturer-installed on one copper-tube extension.
- E. Zone Valve Boxes: Formed steel with anchors for recessed mounting, holes with grommets in box sides for tubing extension protection, and of size for single or multiple valves with pressure gages and in sizes required to permit manual operation of valves.
1. Available Manufacturers: Subject to compliance with requirements, manufacturers offering products that may be incorporated into the Work include, but are not limited to, the following:
 2. Manufacturers: Subject to compliance with requirements, provide products by one of the following:
 3. Basis-of-Design Product: Subject to compliance with requirements, provide the product indicated on Drawings a comparable product by one of the following:
 - a. Allied Healthcare Products, Inc.; Chemetron Div.
 - b. Amico Corporation.
 - c. BeaconMedaes.
 4. Interior Finish: Factory-applied white enamel.
 5. Cover Plate: Aluminum or extruded-anodized aluminum with frangible or removable windows.
 6. Valve-Box Windows: Clear or tinted transparent plastic with labeling that includes rooms served, according to NFPA 99.
- F. Zone Valve Boxes: Formed or extruded aluminum with anchors for recessed mounting, holes with grommets in box sides for tubing extension protection, and of size for single or multiple valves with pressure gages and in sizes required to permit manual operation of valves.
1. Available Manufacturers: Subject to compliance with requirements, manufacturers offering products that may be incorporated into the Work include, but are not limited to, the following:
 2. Manufacturers: Subject to compliance with requirements, provide products by one of the following:

3. Basis-of-Design Product: Subject to compliance with requirements, provide the product indicated on Drawings a comparable product by one of the following:
 - a. Tri-Tech Medical.
 - b. BeaconMedaes.
 - c. Chemetron Div.
 4. Interior Finish: Factory-applied white enamel.
 5. Cover Plate: Aluminum or extruded-anodized aluminum with frangible or removable windows.
 6. Valve-Box Windows: Clear or tinted transparent plastic with labeling that includes rooms served, according to NFPA 99.
- G. Emergency Oxygen Connections: Low-pressure oxygen inlet assembly for connection to building oxygen piping systems.
1. Available Manufacturers: Subject to compliance with requirements, manufacturers offering products that may be incorporated into the Work include, but are not limited to, the following:
 2. Manufacturers: Subject to compliance with requirements, provide products by one of the following:
 3. Basis-of-Design Product: Subject to compliance with requirements, provide the product indicated on Drawings a comparable product by one of the following:
 - a. Allied Healthcare Products, Inc.; Chemetron Div.
 - b. Amico Corporation.
 - c. BeaconMedaes.
 4. Enclosure: Weatherproof hinged locking cover with caption similar to "Emergency Low-Pressure Gaseous Oxygen Inlet."
 5. Inlet: Manufacturer-installed, NPS 1 or NPS 1-1/4 (DN 25 or DN 32), ASTM B 819, copper tubing with NPS 1 (DN 25) minimum ball valve and plugged inlet.
 6. Safety Valve: Bronze-body, pressure relief valve set at 75 or 80 psig (520 or 550 kPa).
 7. Instrumentation: Pressure gage.
- H. Safety Valves: Bronze-body, ASME-construction, poppet, pressure-relief type with settings to match system requirements.
- I. Pressure Regulators: Bronze body and trim; spring-loaded, diaphragm-operated, relieving type; manual pressure-setting adjustment; rated for 250-psig (1725-kPa) minimum inlet pressure; and capable of controlling delivered gas pressure within 0.5 psig for each 10-psig (5.0 kPa for each 100-kPa) inlet pressure.

2.5 MEDICAL GAS SERVICE CONNECTIONS

- A. Available Manufacturers: Subject to compliance with requirements, manufacturers offering products that may be incorporated into the Work include, but are not limited to, the following:
- B. Manufacturers: Subject to compliance with requirements, provide products by one of the following:
- C. Basis-of-Design Product: Subject to compliance with requirements, provide the product indicated on Drawings a comparable product by one of the following:
 - 1. Allied Healthcare Products, Inc.; Chemetron Div.
 - 2. Amico Corporation.
 - 3. BeaconMedaes.
- D. General Requirements for Medical Gas Service Connections,: For specific medical gas pressure and suction service listed. Include roughing-in assemblies, finishing assemblies, and cover plates. Individual cover plates are not required if service connection is in multiple unit or assembly with cover plate. Furnish recessed-type units made for concealed piping unless otherwise indicated.
 - 1. Roughing-in Assembly:
 - a. Steel outlet box for recessed mounting and concealed piping.
 - b. Brass-body outlet block with secondary check valve that will prevent gas flow when primary valve is removed. Suction inlets to be without secondary valve.
 - c. Double seals that will prevent gas leakage.
 - d. ASTM B 819, NPS 3/8 (DN 10) copper outlet tube brazed to valve with service marking and tube-end dust cap.
 - 2. Finishing Assembly:
 - a. Brass housing with primary check valve.
 - b. Double seals that will prevent gas leakage.
 - c. Cover plate with gas-service label.
 - 3. Quick-Coupler Service Connections: Pressure outlets for nitrogen service connections with noninterchangeable keyed indexing to prevent interchange between services, constructed to permit one-handed connection and removal of equipment, and with positive-locking ring that retains equipment stem in valve during use.
 - 4. D.I.S.S. Service Connections: Pressure outlets, complying with CGA V-5, with threaded indexing to prevent interchange between services, constructed to permit one-handed connection and removal of equipment.
 - a. Medical Nitrogen Service Connections: D.I.S.S. No. 1120.
 - 5. Cover Plates: One piece, stainless steel, with NAAMM AMP 503, No. 4 finish and permanent, color-coded, identifying label matching corresponding service.

2.6 MEDICAL NITROGEN PRESSURE CONTROL PANELS

- A. Available Manufacturers: Subject to compliance with requirements, manufacturers offering products that may be incorporated into the Work include, but are not limited to, the following:
- B. Manufacturers: Subject to compliance with requirements, provide products by one of the following:
- C. Basis-of-Design Product: Subject to compliance with requirements, provide the product indicated on Drawings a comparable product by one of the following:
 - 1. BeaconMedaes (Nitrogen Control Panel Series 6-120276-XX) (IA Control Panel Series 6-12-274-00) (Air Control Panel Series 6-120881-00)
- D. Description: Steel box and support brackets for recessed roughing-in with stainless-steel or anodized-aluminum cover plate with printed operating instructions. Include manifold assembly consisting of inlet supply valve, inlet supply pressure gage, line-pressure control regulator, outlet supply pressure gage, D.I.S.S. service connection, and piping outlet for remote service connection.
 - 1. Minimum Working Pressure: 200 psig (1380 kPa).
 - 2. Line-Pressure Control Regulator: Self-relieving diaphragm type with precision manual adjustment.
 - 3. Pressure Gages: 0- to 300-psig (0- to 2070-kPa) range.
 - 4. Service Connection: CGA V-5, D.I.S.S. No. 1120, nitrogen outlet.
 - 5. Before final assembly, provide temporary dust shield and U-tube for testing.
 - 6. Label cover plate "Nitrogen Pressure Control."

2.7 MEDICAL GAS PIPING ALARM SYSTEMS

- A. Available Manufacturers: Subject to compliance with requirements, manufacturers offering products that may be incorporated into the Work include, but are not limited to, the following:
- B. Manufacturers: Subject to compliance with requirements, provide products by one of the following:
- C. Basis-of-Design Product: Subject to compliance with requirements, provide the product indicated on Drawings a comparable product by one of the following:
 - 1. Allied Healthcare Products, Inc.; Chemetron Div.
 - 2. Amico Corporation.
 - 3. BeaconMedaes.
- D. Panels for medical gas piping systems may be combined in single panels with medical compressed-air and medical vacuum piping systems.
- E. Components: Designed for continuous service and to operate on power supplied from 120-V ac power source to alarm panels and with connections for low-voltage wiring to remote sensing devices. Include step-down transformers if required.

- F. Pressure Switches or Pressure Transducer Sensors: Continuous line monitoring with electrical connections for alarm system.
 - 1. Low-Pressure Operating Range: 0- to 100-psig (0- to 690-kPa).
 - 2. High-Pressure Operating Range: Up to 250-psig (1725-kPa).

- G. General Requirements for Medical Gas Alarm Panels: Factory wired with audible and color-coded visible signals to indicate specified functions.
 - 1. Mounting: Recessed installation.
 - 2. Enclosures: Fabricated from minimum 0.047-inch- (1.2-mm-) thick steel or minimum 0.05-inch- (1.27-mm-) thick aluminum, with knockouts for electrical and piping connections.

- H. Master Alarm Panels: With separate trouble alarm signals, pressure gages, and indicators for medical gas piping systems.
 - 1. Include alarm signals when the following conditions exist:
 - a. Medical Carbon Dioxide: Pressure drops below 40 psig (275 kPa) or rises above 60 psig (415 kPa) and changeover is made to alternate bank.
 - b. Medical Nitrogen: Pressure drops below 145 psig (1000 kPa) or rises above 200 psig (1380 kPa) and changeover is made to alternate bank.
 - c. Medical Nitrous Oxide: Liquid level is low, pressure downstream from main shutoff valve drops below 40 psig (275 kPa) or rises above 60 psig (415 kPa), changeover is made to reserve, reserve is in use, and reserve level is low.
 - d. Medical Nitrous Oxide: Pressure drops below 40 psig (275 kPa) or rises above 60 psig (415 kPa) and changeover is made to alternate bank.
 - e. Medical Oxygen: Liquid level is low, pressure downstream from main shutoff valve drops below 40 psig (275 kPa) or rises above 60 psig (415 kPa), changeover is made to reserve, reserve is in use, reserve level is low, and reserve pressure is low.
 - f. Medical Oxygen: Pressure downstream from main shutoff valve drops below 40 psig (275 kPa) or rises above 60 psig (415 kPa) and changeover is made to alternate bank.

- I. Anesthetizing-Area Alarm Panels: Separate trouble alarm signals; pressure gages; and indicators for medical gas piping systems.
 - 1. Include alarm signals when the following conditions exist:
 - a. Medical Carbon Dioxide: Pressure drops below 40 psig (275 kPa) or rises above 60 psig (415 kPa).
 - b. Medical Nitrous Oxide: Pressure drops below 40 psig (275 kPa) or rises above 60 psig (415 kPa).
 - c. Medical Nitrogen: Pressure drops below 145 psig (1000 kPa) or rises above 200 psig (1380 kPa).

- d. Medical Oxygen: Pressure drops below 40 psig (275 kPa) or rises above 60 psig (415 kPa).
- J. Area Alarm Panels: Separate trouble alarm signals; pressure and vacuum gages; and indicators for medical gas piping systems.
 - 1. Include alarm signals when the following conditions exist:
 - a. Oxygen: Pressure drops below 40 psig (275 kPa) or rises above 60 psig (415 kPa).

2.8 COMPUTER INTERFACE CABINET

- A. Description: Wall-mounting, welded-steel, control cabinet with gasketed door, mounting brackets, grounding device, and white-enamel finish for connection of medical gas system alarms to facility computer. Include factory-installed signal circuit boards, power transformer, circuit breaker, wiring terminal board, and internal wiring capable of interfacing 20 alarm signals.

2.9 SLEEVES

- A. Galvanized-Steel Sheet: 0.0239-inch (0.6-mm) minimum thickness; round tube closed with welded longitudinal joint.
- B. Stack Sleeve Fittings: Manufactured, cast-iron sleeve with integral clamping flange. Include clamping ring and bolts and nuts for membrane flashing.
 - 1. Underdeck Clamp: Clamping ring with set screws.

2.10 ESCUTCHEONS

- A. General Requirements for Escutcheons: Manufactured wall and ceiling escutcheons and floor plates, with ID to closely fit around pipe and tube and OD that completely covers opening.
- B. One-Piece, Deep-Pattern Escutcheons: Deep-drawn, box-shaped brass with polished chrome-plated finish.
- C. One-Piece, Cast-Brass Escutcheons: With set screw.
 - 1. Finish: Polished chrome-plated.
- D. Split-Casting, Cast-Brass Escutcheons: With concealed hinge and set screw.
 - 1. Finish: Polished chrome-plated.
- E. One-Piece, Stamped-Steel Escutcheons: With set screw and chrome-plated finish.

- F. Split-Plate, Stamped-Steel Escutcheons: With concealed hinge, set screw, and chrome-plated finish.
- G. One-Piece, Floor-Plate Escutcheons: Cast iron.
- H. Split-Casting, Floor-Plate Escutcheons: Cast brass with concealed hinge and set screw.

2.11 GROUT

- A. Description: ASTM C 1107, Grade B, nonshrink and nonmetallic, dry hydraulic-cement grout.
 - 1. Characteristics: Post-hardening, volume adjusting, nonstaining, noncorrosive, nongaseous, and recommended for interior and exterior applications.
 - 2. Design Mix: 5000-psi (34.5-MPa), 28-day compressive strength.
 - 3. Packaging: Premixed and factory packaged.

2.12 NITROGEN

- A. Description: Comply with USP 28 - NF 23 for oil-free dry nitrogen.

PART 3 - EXECUTION

3.1 PREPARATION

- A. Cleaning of Medical Gas Tubing: If manufacturer-cleaned and -capped fittings or tubing are not available or if precleaned fittings or tubing must be recleaned because of exposure, have supplier or separate agency acceptable to authorities having jurisdiction, perform the following procedures:
 - 1. Clean medical gas tube and fittings, valves, gages, and other components of oil, grease, and other readily oxidizable materials as required for oxygen service according to CGA G-4.1, "Cleaning Equipment for Oxygen Service."
 - 2. Wash medical gas tubing and components in hot, alkaline-cleaner-water solution of sodium carbonate or trisodium phosphate in proportion of 1 lb (0.453 kg) of chemical to 3 gal. (11.3 L) of water.
 - a. Scrub to ensure complete cleaning.
 - b. Rinse with clean, hot water to remove cleaning solution.

3.2 PIPING APPLICATIONS

- A. Medical Gas Piping: Use Type L, copper medical gas tube; wrought-copper fittings; and brazed joints.

- B. Medical Nitrogen Piping: Type L, copper medical gas tube; wrought-copper fittings; and brazed joints.
- C. Medical Nitrogen Piping NPS 2-1/2 (DN 65) and Smaller: Type K, copper medical gas tube; wrought-copper fittings; and brazed joints.
- D. Medical Nitrogen Piping NPS 3 (DN 80) and Larger: Type K, copper tube; wrought-copper fittings; and brazed joints.

3.3 PIPING INSTALLATION

- A. Drawing plans, schematics, and diagrams indicate general location and arrangement of gas piping. Indicated locations and arrangements were used to size pipe and calculate friction loss, expansion, air-compressor sizing, and other design considerations. Install piping as indicated unless deviations to layout are approved on Coordination Drawings.
- B. Comply with ASSE Standard #6010 for installation of medical gas piping.
- C. Install piping concealed from view and protected from physical contact by building occupants unless otherwise indicated and except in equipment rooms and service areas.
- D. Install piping indicated to be exposed and piping in equipment rooms and service areas at right angles or parallel to building walls. Diagonal runs are prohibited unless specifically indicated otherwise.
- E. Install piping above accessible ceilings to allow sufficient space for ceiling panel removal and coordinate with other services occupying that space.
- F. Install piping adjacent to equipment and specialties to allow service and maintenance.
- G. Install nipples, unions, and special fittings, and valves with pressure ratings same as or higher than system pressure rating used in applications below unless otherwise indicated.
- H. Install piping to permit valve servicing.
- I. Install piping free of sags and bends.
- J. Install fittings for changes in direction and branch connections.
- K. Install medical gas piping to medical gas service connections specified in this Section, to medical gas service connections in equipment specified in this Section, and to equipment specified in other Sections requiring medical gas service.
- L. Install exterior, buried medical gas piping in protective conduit fabricated with PVC pipe and fittings. Do not extend conduit through foundation wall.

- M. Install seismic restraints on gas piping. Seismic-restraint devices are specified in Division 22 Section "Vibration and Seismic Controls for Plumbing Piping and Equipment."
- N. Install medical gas service connections recessed in walls. Attach roughing-in assembly to substrate; attach finishing assembly to roughing-in assembly.
- O. Connect gas piping to gas sources and to gas outlets and equipment requiring gas service.
- P. Install unions, in copper tubing adjacent to each valve and at final connection to each piece of equipment and specialty.

3.4 VALVE INSTALLATION

- A. Install shutoff valve at each connection to gas laboratory and healthcare equipment and specialties.
- B. Install check valves to maintain correct direction of gas flow from laboratory and healthcare gas supplies.
- C. Install valve boxes recessed in wall and anchored to substrate. Single boxes may be used for multiple valves that serve same area or function.
- D. Install zone valves and gages in valve boxes. Rotate valves to angle that prevents closure of cover when valve is in closed position.
- E. Install pressure regulators on gas piping where reduced pressure is required.
- F. Install emergency oxygen connection with pressure relief valve and full-size discharge piping to outside, with check valve downstream from pressure relief valve and with ball valve and check valve in supply main from bulk oxygen storage tank.

3.5 JOINT CONSTRUCTION

- A. Remove scale, slag, dirt, and debris from outside of cleaned tubing and fittings before assembly.
- B. Threaded Joints: Apply appropriate tape to external pipe threads.
- C. Brazed Joints: Join copper tube and fittings according to CDA's "Copper Tube Handbook," "Braze Joints" Chapter. Continuously purge joint with oil-free, dry nitrogen during brazing.
- D. Pressure-Sealed Joints: Join copper tube and press-type fittings with tools recommended by fitting manufacturer.
- E. Memory-Metal Coupling Joints: Join new copper tube to existing tube according to procedures developed by fitting manufacturer for installation of memory-metal coupling joints.

3.6 GAS SERVICE COMPONENT INSTALLATION

- A. Assemble patient service console with service connections. Install with supplies concealed, in walls. Attach console box or mounting bracket to substrate.
- B. Install nitrogen pressure-control panels in walls. Attach to substrate.
- C. Assemble ceiling columns and install anchored to substrate. Provide structural steel, hanger rods, anchors, and fasteners in addition to components furnished with specialties necessary to fabricate supports.
- D. Assemble ceiling assemblies and install anchored to substrate. Provide structural steel, hanger rods, anchors, and fasteners in addition to components furnished with specialties necessary to fabricate supports.
- E. Install gas manifolds anchored to substrate.
- F. Install gas cylinders and connect to manifold piping.
- G. Install gas manifolds with seismic restraints as indicated.
- H. Install bulk gas storage tanks and reserve supply tanks level on concrete bases. Set tanks and connect gas piping to tanks. Install tanks level and plumb, firmly anchored to concrete bases; maintain NFPA 50 and tank manufacturer's recommended clearances. Orient tanks so controls and devices are accessible for servicing.
- I. Install bulk gas storage tanks and reserve supply tanks with seismic restraints.

3.7 MEDICAL GAS PIPING ALARM SYSTEM INSTALLATION

- A. Install medical gas alarm system components in locations required by and according to NFPA 99.
- B. Install medical gas area and master alarm panels where indicated.
- C. Install computer interface cabinet with connection to medical gas piping alarm system and facility computer.

3.8 SLEEVE INSTALLATION

- A. Sleeves are not required for core-drilled holes.
- B. Permanent sleeves are not required for holes formed by removable PE sleeves.
- C. Install sleeves for pipes passing through concrete and masonry walls and concrete floor and roof slabs using galvanized-steel pipe.
 - 1. Wall Penetrations: Cut sleeves to length for mounting flush with both surfaces.

2. Floor Penetrations: Extend sleeves installed in floors of mechanical equipment areas or other wet areas 2 inches (50 mm) above finished floor level. Extend cast-iron sleeve fittings below floor slab as required to secure clamping ring if ring is specified.
- D. Install sleeves in new walls and slabs as new walls and slabs are constructed.
 - E. Install sleeves that are large enough to provide 1/4-inch (6.4-mm) annular clear space between sleeve and pipe or pipe insulation. Use the following sleeve materials:
 1. Steel Pipe Sleeves: For pipes smaller than NPS 6 (DN 150).
 2. Steel Sheet Sleeves: For pipes NPS 6 (DN 150) and larger, penetrating gypsum board partitions.
 3. Stack Sleeve Fittings: For pipes penetrating floors with membrane waterproofing. Secure flashing between clamping flanges. Install section of cast-iron soil pipe to extend sleeve to 2 inches (50 mm) above finished floor level. Comply with requirements in Division 07 Section "Sheet Metal Flashing and Trim" for flashing.
 - a. Seal space outside of sleeve fittings with grout.
 - F. Fire-Barrier Penetrations: Maintain indicated fire rating of walls, partitions, ceilings, and floors at pipe penetrations. Seal pipe penetrations with firestop materials. Comply with requirements in Division 07 Section "Penetration Firestopping."

3.9 ESCUTCHEON INSTALLATION

- A. Install escutcheons for penetrations of walls, ceilings, and floors according to the following:
 1. New Piping:
 - a. Piping with Fitting or Sleeve Protruding from Wall: One piece, deep pattern.
 - b. Bare Piping at Wall and Floor Penetrations in Finished Spaces: One piece, cast brass with polished chrome-plated finish.
 - c. Bare Piping at Ceiling Penetrations in Finished Spaces: One piece, cast brass with polished chrome-plated finish.
 - d. Bare Piping in Unfinished Service Spaces: One piece, cast brass with polished chrome-plated finish.
 - e. Bare Piping in Equipment Rooms: One piece, cast brass.
 - f. Bare Piping at Floor Penetrations in Equipment Rooms: One-piece floor plate.

3.10 HANGER AND SUPPORT INSTALLATION

- A. Comply with requirements in Division 22 Section "Vibration and Seismic Controls for Plumbing Piping and Equipment" for seismic-restraint devices.

- B. Comply with requirements in Division 22 Section "Hangers and Supports for Plumbing Piping and Equipment" for pipe hanger and support devices.
- C. Vertical Piping: MSS Type 8 or 42, clamps.
- D. Individual, Straight, Horizontal Piping Runs:
 - 1. 100 Feet (30 m) and Less: MSS Type 1, adjustable, steel, clevis hangers.
 - 2. Longer Than 100 Feet (30 m): MSS Type 43, adjustable, roller hangers.
- E. Multiple, Straight, Horizontal Piping Runs 100 Feet (30 m) or Longer: MSS Type 44, pipe rolls. Support pipe rolls on trapeze. Comply with requirements in Division 22 Section "Hangers and Supports for Plumbing Piping and Equipment" for trapeze hangers.
- F. Base of Vertical Piping: MSS Type 52, spring hangers.
- G. Support horizontal piping within 12 inches (300 mm) of each fitting and coupling.
- H. Rod diameter may be reduced 1 size for double-rod hangers, with 3/8-inch (10-mm) minimum rods.
- I. Install hangers for copper tubing with the following maximum horizontal spacing and minimum rod diameters:
 - 1. NPS 1/4 (DN 8): 60 inches (1500 mm) with 3/8-inch (10-mm) rod.
 - 2. NPS 3/8 and NPS 1/2 (DN 10 and DN 15): 72 inches (1800 mm) with 3/8-inch (10-mm) rod.
 - 3. NPS 3/4 (DN 20): 84 inches (2100 mm) with 3/8-inch (10-mm) rod.
 - 4. NPS 1 (DN 25): 96 inches (2400 mm) with 3/8-inch (10-mm) rod.
 - 5. NPS 1-1/4 (DN 32): 108 inches (2700 mm) with 3/8-inch (10-mm) rod.
 - 6. NPS 1-1/2 (DN 40): 10 feet (3 m) with 3/8-inch (10-mm) rod.
 - 7. NPS 2 (DN 50): 11 feet (3.4 m) with 3/8-inch (10-mm) rod.
 - 8. NPS 2-1/2 (DN 65): 13 feet (4 m) with 1/2-inch (13-mm) rod.
 - 9. NPS 3 (DN 80): 14 feet (4.3 m) with 1/2-inch (13-mm) rod.
 - 10. NPS 3-1/2 (DN 90): 15 feet (4.6 m) with 1/2-inch (13-mm) rod.
 - 11. NPS 4 (DN 100): 16 feet (4.9 m) with 1/2-inch (13-mm) rod.
 - 12. NPS 5 (DN 125): 18 feet (5.5 m) with 1/2-inch (13-mm) rod.
 - 13. NPS 6 (DN 150): 20 feet (6 m) with 5/8-inch (16-mm) rod.
 - 14. NPS 8 (DN 200): 23 feet (7 m) with 3/4-inch (19-mm) rod.
- J. Install supports for vertical copper tubing every 10 feet (3 m).

3.11 LABELING AND IDENTIFICATION

- A. Install identifying labels and devices for specialty gas piping, valves, and specialties. Comply with requirements in Division 22 Section "Identification for Plumbing Piping and Equipment."

- B. Install identifying labels and devices for healthcare medical gas piping systems according to NFPA 99. Use the following or similar captions and color-coding for piping products where required by NFPA 99:
 - 1. Carbon Dioxide: Black or white letters on gray background.
 - 2. Nitrogen: White letters on black background.
 - 3. Nitrous Oxide: White letters on blue background.
 - 4. Oxygen: White letters on green background or green letters on white background.

3.12 FIELD QUALITY CONTROL FOR LABORATORY FACILITY SPECIALTY GAS

- A. Testing Agency: Engage qualified testing agency to perform field tests and inspections of specialty gas piping for nonhealthcare laboratory facilities and prepare test reports.
- B. Perform field tests and inspections of specialty gas piping for nonhealthcare laboratory facilities and prepare test reports.
- C. Tests and Inspections:
 - 1. Piping Leak Tests for Specialty Gas Piping: Test new and modified parts of existing piping. Cap and fill specialty gas piping with oil-free, dry nitrogen to pressure of 50 psig (345 kPa) above system operating pressure, but not less than 150 psig (1035 kPa). Isolate test source and let stand for four hours to equalize temperature. Refill system, if required, to test pressure; hold for two hours with no drop in pressure.
 - 2. Repair leaks and retest until no leaks exist.
 - 3. Inspect specialty gas regulators for proper operation.

3.13 FIELD QUALITY CONTROL FOR HEALTHCARE FACILITY MEDICAL GAS

- A. Testing Agency: Engage a qualified testing agency to perform tests and inspections of medical gas piping systems in healthcare facilities and prepare test reports.
- B. Perform tests and inspections of medical gas piping systems in healthcare facilities and prepare test reports.
- C. Tests and Inspections:
 - 1. Medical Gas Piping Testing Coordination: Perform tests, inspections, verifications, and certification of medical gas piping systems concurrently with tests, inspections, and certification of medical compressed-air piping and medical vacuum piping systems.
 - 2. Preparation: Perform the following Installer tests according to requirements in NFPA 99 and ASSE Standard #6010:
 - a. Initial blow down.
 - b. Initial pressure test.

- c. Cross-connection test.
 - d. Piping purge test.
 - e. Standing pressure test for positive pressure medical gas piping.
 - f. Standing pressure test for vacuum systems.
 - g. Repair leaks and retest until no leaks exist.
 3. System Verification: Comply with requirements in NFPA 99, ASSE Standard #6020, and ASSE Standard #6030 for verification of medical gas piping systems and perform the following tests and inspections:
 - a. Standing pressure test.
 - b. Individual-pressurization cross-connection test.
 - c. Valve test.
 - d. Master and area alarm tests.
 - e. Piping purge test.
 - f. Piping particulate test.
 - g. Piping purity test.
 - h. Final tie-in test.
 - i. Operational pressure test.
 - j. Medical gas concentration test.
 - k. Medical air purity test.
 - l. Verify correct labeling of equipment and components.
 - m. Verify the following source equipment:
 - 1) Medical gas supply sources.
 4. Testing Certification: Certify that specified tests, inspections, and procedures have been performed and certify report results. Include the following:
 - a. Inspections performed.
 - b. Procedures, materials, and gases used.
 - c. Test methods used.
 - d. Results of tests.
- D. Remove and replace components that do not pass tests and inspections and retest as specified above.

3.14 DEMONSTRATION

- A. Train Owner's maintenance personnel to adjust, operate, and maintain bulk gas storage tanks and medical gas alarm system. Refer to Division 01 Section "Demonstration and Training."

END OF SECTION

TABLE OF CONTENTS

HEATING VENTILATING AND AIR CONDITIONING

SECTION NUMBER	SECTION TITLE
23 00 00	GENERAL PROVISIONS FOR HEATING, VENTILATING AND AIR CONDITIONING
23 00 01	SUPPLEMENTARY CONDITIONS FOR MECHANICAL, ELECTRICAL, PLUMBING AND AIR CONDITIONING
23 01 30	HVAC AIR DUCT CLEANING
23 05 00	COMMON WORK RESULTS FOR HVAC
23 05 12	BEARING PROTECTION RING FOR MOTORS
23 05 13	COMMON MOTOR REQUIREMENTS FOR HVAC EQUIPMENT
23 05 14	ENCLOSED CONTROLLERS
23 05 15	VARIABLE-FREQUENCY MOTOR CONTROLLERS
23 05 16	EXPANSION FITTINGS AND LOOPS FOR HVAC PIPING
23 05 19	METERS AND GAGES FOR HVAC PIPING
23 05 23	GENERAL-DUTY VALVES FOR HVAC PIPING
23 05 29	HANGERS AND SUPPORTS FOR HVAC PIPING AND EQUIPMENT
23 05 33	HEAT TRACING FOR HVAC PIPING
23 05 48	MECHANICAL VIBRATION ISOLATION AND SEISMIC RESTRAINT SYSTEMS
23 05 49	NOISE CONTROL AND ACOUSTICAL PERFORMANCE
23 05 53	IDENTIFICATION FOR HVAC PIPING AND EQUIPMENT
23 05 93	TESTING, ADJUSTING, AND BALANCING FOR HVAC
23 07 00	HVAC INSULATION
23 08 00	COMMISSIONING OF HVAC
23 09 00	HVAC INSTRUMENTATION AND CONTROLS
23 09 93	SEQUENCE OF OPERATIONS
23 21 13	HYDRONIC PIPING
23 21 23	HYDRONIC PUMPS
23 22 13	STEAM AND CONDENSATE HEATING PIPING
23 22 23	STEAM CONDENSATE PUMPS
23 25 00	HVAC WATER TREATMENT
23 31 13	METAL DUCTS

23 33 00	AIR DUCT ACCESSORIES
23 34 16	CENTRIFUGAL HVAC FANS
23 34 23	HVAC POWER VENTILATORS
23 36 00	AIR TERMINAL UNITS
23 37 13	DIFFUSERS, REGISTERS, AND GRILLES
23 57 00	HEAT EXCHANGERS FOR HVAC
23 73 14	CUSTOM PACKAGED CENTRAL-STATION AIR-HANDLING UNITS
23 81 26	SPLIT-SYSTEM AIR-CONDITIONERS
23 82 39	UNIT HEATERS
23 83 16	HYDRONIC RADIANT SNOW MELT SYSTEM
23 83 23	RADIANT-HEATING PANELS
23 84 13	HUMIDIFIERS

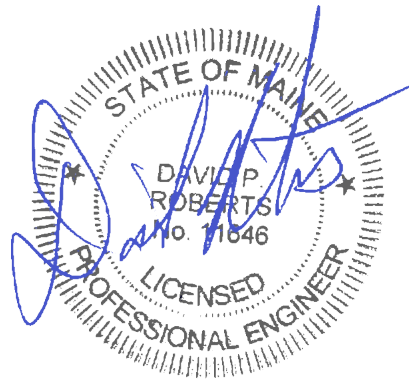

SECTION 23 00 00

GENERAL PROVISIONS FOR HEATING, VENTILATING AND AIR CONDITIONING WORK

PART 1 - GENERAL

1.1 WORK INCLUDED

- A. Work in this Section includes the providing of labor, materials, equipment and services necessary for a complete and safe installation in accordance with the contract documents and all applicable codes and authorities having jurisdiction for heating, ventilating and air conditioning work covered by all sections within Division 23 of the specifications (including but not limited to HVAC systems and equipment).
- B. Provide cutting and patching, except as noted in "AIA Document A210" and "Supplementary Conditions for Mechanical and Electrical Work."
- C. Provide piping extensions and connections from capped Plumbing terminations, for makeup water and other such services.
- D. Provide drainage from noted equipment to floor drains, roof, sink, or funnel drains.
- E. Provide piping connections to equipment, as required, for kitchens, sterilizers, kitchenettes, and as indicated.
- F. Provide 3/8" coordinated shop drawings with a sheetmetal construction drawing as the base drawing; and overlay plumbing, fire protection, and electrical systems for coordination.
- G. Related Work And Requirements
 - 1. Requirements of general conditions, supplementary conditions for mechanical and electrical work and Division No. 1.
 - 2. Requirements noted under other Divisions of Work
- H. Section 01 81 13 "Sustainable Design Requirements – LEED v4 for Building Design & Construction – New Construction" for sustainable design requirements and detailed sustainable design submittal requirements.
- I. Section 01 74 19 "Construction and Demolition Waste Management and Disposal" for disposal of construction, demolition and packaging waste disposal requirements.

1.2 WORK NOT INCLUDED:

- 1. Providing temporary heat.
- 2. Providing finish painting.
- 3. Installing building construction access door filler.
- 4. Providing trench covers and frames.
- 5. Cutting and patching, except as noted in "AIA Document A201" and "Supplementary Conditions for Mechanical and Electrical Work."
- 6. Excavating and backfilling under building.
- 7. Excavating and backfilling.
- 8. Providing exterior louvers.
- 9. Providing undercut and louvers in doors.

10. Providing exterior wall louvers intake, screens and exterior attenuation panels.
11. Providing plenums other than sheet metal.
12. Providing flashing.
13. Providing shaft gratings.
14. Providing equipment platforms.

1.3 DESCRIPTION OF BID DOCUMENTS

- A. Specifications, in general, describe quality and character of materials and equipment.
- B. Drawings, in general are diagrammatic and indicate sizes, locations, connections to equipment and methods of installation. Provide additional offsets, fittings, hangers, supports, valves, drains as required for construction and coordination with work of other trades.
- C. Scaled and indicated dimensions are approximate and are for estimating purposes only. Before proceeding with work, check and verify all dimensions.
- D. Make adjustments that may be necessary or requested in order to resolve space problems, preserve headroom, and avoid architectural openings, structural members and work of other trades.
- E. Typical details, where shown on the drawings, apply to each and every item of the project where such items are applicable. Typical details are not repeated in full on the plans, and are diagrammatic only, but with the intention that such details shall be incorporated in full.
- F. If any part of Specifications or Drawings appears unclear or contradictory, consult Architect and/or Engineer for interpretation and decision as early as possible during bidding period. Do not proceed with work without the Architect's and/or Engineer's decision.

1.4 DEFINITIONS

- A. "Furnish" or "provide": to supply, install and make complete, safe, and operable, the particular work referred to unless specifically indicated otherwise.
- B. "Install": to erect, mount and make complete with all related accessories.
- C. "Supply": to purchase, procure, acquire, and deliver complete with related accessories.
- D. "Work": includes labor, materials, equipment, services, and all related accessories necessary for the proper and complete installation of complete systems.
- E. "Piping": includes pipe, tube, fittings, flanges, valves, controls, strainers, hangers, supports, unions, traps, drains, insulation, and all related accessories.
- F. "Wiring": includes raceway, fittings, wire, boxes, and all related accessories.
- G. "Concealed": not in view, installed in masonry or other construction, within furred spaces, double partitions, hung ceilings, trenches, crawl spaces, or enclosures.
- H. "Exposed": in view, not installed underground or "concealed" as defined above.
- I. "Indicated," "shown," or "noted": as indicated, shown or noted on drawings or specifications.

- J. "Similar" or "equal" of base bid manufacturer, equal in quality, materials, weight, size, performance, design and efficiency of specified product, conforming with "Base Bid Manufacturers."
- K. "Reviewed," "satisfactory," "accepted," or "directed" as reviewed, satisfactory, accepted, or directed by or to Architect and/or Engineer.
- L. "Motor Controllers": includes manual or magnetic starters with or without switches, individual pushbuttons or hand-off-automatic (HOA) switches controlling the operation of motors.
- M. "Control or Actuating Devices": includes automatic sensing and switching devices such as thermostats, pressure, float, flow, electro-pneumatic switches and electrodes controlling operation of equipment.

1.5 QUALITY ASSURANCE

- A. All equipment and accessories shall be the product of manufacturers regularly engaged in their manufacture. All items of a given type shall be the products of the same manufacturer.
- B. Furnish all equipment and accessories new and free from defects.
- C. All electrical equipment shall be listed by Underwriters' Laboratories, Inc. (UL) or bear UL labels.
- D. Supply all equipment and accessories in complete compliance with and in accordance with the applicable standards listed in reference standards of this Section and with all applicable national, state and local codes.

1.6 JOB CONDITIONS

- A. Inspection of Site Conditions:
 - 1. Before starting work, visit the site and examine the conditions under which the work has to be performed. Report in writing any conditions which might adversely affect the work.
- B. Hazardous locations:
 - 1. Provide required material, equipment and installation applicable for hazardous location defined by codes.
 - 2. Provide material, equipment and installation as required for Class, Division and Group noted.

1.7 REFERENCE STANDARDS

- A. Published specifications, standards tests, or recommended methods of trade, industry or governmental organizations apply to work in all Sections as noted below:
 - 1. ASHRAE - American Society of Heating, Refrigerating and Air Conditioning engineers.
 - 2. AABC - Associated Air Balance Controls.
 - 3. AMCA - Air Moving and Conditioning Association.
 - 4. ADC - Air Diffuser Council.
 - 5. NEMA - National Electrical Manufacturers' Association.
 - 6. ANSI - American National Standards Institute.
 - 7. ASME - American Society of Mechanical Engineers.
 - 8. ASTM - American Society for Testing and Materials.

9. NFPA - National Fire Protection Association.
10. ARI - Air-Conditioning and Refrigeration Institute.
11. UL - Underwriters' Laboratories, Inc.
12. OSHA - Occupational Safety and Health Administration Regulations.

B. Codes:

1. This installation is to abide by all applicable codes including, but not limited to:
 - a. International Building Code-2009/Maine State Building Code including all amendments.

1.8 SUBMITTALS

- A. Submit shop drawings product data, samples and certificates of compliance required by contract documents, "AIA Document 201" and "SUPPLEMENTARY CONDITIONS FOR MECHANICAL AND ELECTRICAL WORK."
- B. Operating instructions, maintenance manuals and parts lists.
 1. Provide five sets of manufacturer's equipment brochures and service manuals consisting of the following:
 - a. Descriptive literature for equipment and components.
 - b. Model number and performance data.
 - c. Installation and operating instructions.
 - d. Maintenance and repair instructions.
 - e. Recommended spare parts lists.
 2. Assemble manufacturers' equipment manuals in chronological order following the specifications' numbering system using heavy duty three ring binders.
 3. Submit valve tag chart.
 4. Submit three sets of field test reports including instrument set points and normal operating valves.
- C. Submit to the Construction Manager all testing and certification documentation as required to comply in all respects with the U.S. Green Building Council/LEED®.

1.9 AS-BUILT DRAWINGS

- A. Provide as-built drawings of all work modified from the construction documents in the field during the construction phase.

1.10 CLEARANCE FROM ELECTRICAL EQUIPMENT

- A. Piping and ductwork is prohibited in electric and telephone rooms and closets, elevator machine rooms, and for installations over or within 5 ft of transformers, substations, switchboards, motor control centers, standby power plants, and motors.
- B. Branch piping to equipment is acceptable when installed over or within 5 ft of motors.

1.11 DRIP PANS

- A. Provide drip pans under piping when installation over or within 5 ft of electrical apparatus is unavoidable or in rooms containing electrical equipment. Pan shall be reinforced, properly supported and made watertight. Provide enclosed type for

pressure piping. Extend 1-1/4 in. drain pipe from pan to spill over nearest floor drain, janitors sink or as indicated.

1. Construction shall be 18 gauge galvanized sheet steel. Pans shall be constructed to retain 3 inches of water minimum.
2. BMS Contractor shall install a waterflow detector for BMS alarm in case of a water leak.

1.12 PRODUCT, DELIVERY, HANDLING AND STORAGE

- A. Ship materials and equipment in crated sections of sizes to permit passing through available space, where required
- B. Deliver equipment with protective crating and shrink-wrapped covering.
- C. Receive and accept materials and equipment at the site, properly handle, house, and protect them from damage and the weather until installation. Replace equipment damaged in the course of handling without additional charge.
- D. Store to prevent damage and protect from weather, dirt, fumes, water, and construction debris in clean dry space
- E. Arrange for and provide storage space or area at the job site for all materials and equipment to be received and/or installed in this project
- F. All exposed openings of equipment, piping and ductwork are to be covered nightly and/or when no work is anticipated for more than 4 hours.
- G. Handle according to manufacturer's written rigging and installation instructions for unloading, transporting, and setting in final location
- H. Protect units from physical damage. Leave factory shipping covers in place until installation

1.13 TEMPORARY HEAT

- A. Temporary heat will be provided under General Construction Work.

1.14 ACCESSIBILITY

- A. Install all work so that parts requiring periodic inspection, operation, maintenance, and repair are readily accessible. Minor deviations from the drawings may be made to accomplish this, but changes of substantial magnitude shall not be made without written approval.
- B. Group concealed valves, expansion joints, controls, dampers, and equipment requiring access, so as to be freely accessible through access doors.

1.15 SPECIAL TOOLS

- A. Provide one set of any special tools required to operate, adjust, dismantle or repair equipment furnished under this Division for the Owner's use at the completion of the work.
- B. Provide one pressure grease gun with adapters for each type of grease required.
- C. Provide one suitable tool case for special tools.

1.16 CUTTING AND PATCHING

- A. Provide all carpentry, cutting and patching required for proper installation of materials and equipment specified. Do not cut or drill structural members without review by Architect and Structural Engineer.

1.17 PROTECTION OF MATERIALS

- A. Protect from damage, water, dust, etc., materials, equipment and apparatus provided under this trade, both in storage and installed

1.18 SUBSTITUTIONS

- A. No substitute material or manufacturer of equipment shall be permitted without a formal written submittal to the Construction Manager and Architect which includes all dimensional, performance and material specifications and is approved in writing by the engineer. Any changes in layout or design brought about by the use of a substitution shall be submitted to the Construction Manager and Architect fully designed for review in conjunction with the submittal of the alternate. Any substitution must be submitted with an explanation why a substitution is being proposed. If the substitute is being proposed for financial reasons, the associated credit must be simultaneously submitted. Final acceptance or rejection of any substitution is subject to the owner's review.

1.19 STANDARDS:

- A. If any item in the specification, as furnished by the contractor, is manufactured in a location which does not certify ASME/ANSI standards, the contractor is to pay the Construction Manager/Owner for ALL expenses incurred by the Construction Manager/Owner for an outside testing company to confirm such compliance.

1.20 COORDINATION

- A. Arrange for pipe spaces, duct spaces, space for equipment, chases, slots, and openings in building structure during progress of construction, to allow for mechanical installations.
- B. Coordinate installation of required supporting devices and set sleeves in poured-in-place concrete and other structural components as they are constructed.
- C. Coordinate requirements for access panels and doors for mechanical items requiring access that are concealed behind finished surfaces.
- D. Provide coordination drawing for all areas of the work. The drawings shall have the following qualities:
 1. Minimum 3/8" scale
 2. Clearly show all the work for each trade including, but not limited to hangers, valves, dampers, actuators, access doors and service access requirements for all items.
 3. Indicate bottom elevations of all ductwork, electrical conduit, raceways, cable trays, control wiring and piping.
 4. Ductwork, piping, and conduit 3 inches and smaller may be shown in single line.
 5. Ductwork, piping, and conduit greater than 3 inches shall be shown in double line.
 6. Color scheme:
 - a. Architectural and structural background: Light grey.

- b. Ductwork: Black.
- c. Equipment and pads: Purple.
- d. HVAC piping and equipment: Green.
- e. Electrical conduits and equipment: Blue.
- f. Plumbing: Orange.
- g. Fire protection: Red.
- h. Control wiring: Pink.

1.21 GUARANTEE

- A. In accordance with General Conditions (AIA Document 201) & Supplementary Conditions for Mechanical & Electrical Work.
- B. The Contractor shall furnish a written guarantee to replace or repair promptly and assume responsibility for all expenses incurred for any workmanship and equipment in which defects develop within one year from the date of final certificate for payment and/or from date of actual use of equipment or occupancy of spaces by Owner included under the various parts of work, whichever date is earlier. This work shall be done as directed by the Owner. This guarantee shall also provide that where defects occur, the Contractor will assume responsibility for all expenses incurred in repairing and replacing work of other trades affected by defects, repairs or replacements in equipment supplied by the Contractor.

1.22 PERMITS AND FEES

- A. In accordance with General Conditions (AIA Document 201) & Supplementary Conditions for Mechanical & Electrical Work.
- B. The Contractor shall give necessary notice, file drawings and specifications with the department having jurisdiction, obtain permits or licenses necessary to carry out this work and pay all fees therefore. The Contractor shall arrange for inspection and test of any or all parts of the work if so required by authorities and pay all charges for same. The Contractor shall pay all costs for, furnish to the Owner before final billing, all certificates necessary as evidence that the work installed conforms with all regulations where they apply to this work.

1.23 RIGGING

- A. This contractor shall provide all required rigging, hoisting and bracing to install the equipment as indicated on the plans. This work shall be performed by an insured certified licensed rigging company that is experienced in rigging equipment of the type indicated for the areas shown on the construction documents. This contractor shall submit rigging plans for approval prior to proceeding with the work.
- B. All permits required from the authorities and agencies involved to perform the rigging are the responsibilities of this contractor.
- C. All structural supports, modifications or additions are to be submitted to the structural engineer for approval prior to proceeding with the work. All supplemental structural supports, elevator charges /modifications, bracing and protection required for the rig is the responsibility of this contractor
- D. The rigging contractor shall hire and pay for all charges and services of the building elevator contractor for the rigging of the equipment

1.24 COMMISSIONING

- A. Provisions Included
 - 1. Include Division 00 and applicable parts of Division 01 for conditions and requirements which may affect the work of this Section.
 - 2. Examine all other Sections of the specifications for requirements which affect work under this Section whether or not such work is specifically mentioned in this Section.
 - 3. Coordinate work with that of all other Trades affecting, or affected by work of this Section. Cooperate with such Trades to ensure the steady progress of all work under the Contract.
 - 4. This scope is not all inclusive of the overall effort necessary to fully commission this project but rather serves as a guide. Refer to the Commissioning Plan and Section provided by the Construction Manager for further details. Refer to Sections 019100- Commissioning and Section 230800- Commissioning of HVAC for further scope and responsibility required.
- B. Commissioning Effort
 - 1. The Construction Manager shall be the prime contractor which is responsible for the overall commissioning program.
 - 2. The Construction Manager and all Contractors/Subcontractors shall completely assist the Commissioning Agent in establishing and maintaining the schedule of commissioning events, as developed for the complete check out of each individual mechanical and electrical sub-system and the integration of all building systems.
 - 3. The Contractor, BMS Contractor and TAB Contractor responsible for all work, installation, testing, balancing and controls under this Division shall be responsible to provide all set up, testing and services required in the commissioning of the systems under this Division.
- C. Commissioning Team
 - 1. A representative of each of the following parties shall be designated as a member of the Commissioning Team.
 - 2. Each member must attend weekly "schedule of events" meetings, in accordance with the Commissioning Agent's schedule.
 - 3. Each member must be closely associated with this design project to accommodate the actual scheduling of events upon mechanical and electrical systems which have been "completed" and thus in proper operation to be commissioned.
 - 4. Commissioning Team
 - 5. Commissioning Agent
 - a. Construction Manager
 - b. HVAC Contractor
 - c. BMS Contractor
 - d. Testing and Balancing Contractor (TAB)
 - e. Plumbing Contractor
 - f. Fire Protection Contractor
 - g. Electrical Contractor
 - h. Selective Equipment Manufacturers
 - i. Owners Designated Representative
- D. Substantial Completion
 - 1. The Construction Manager shall submit written notice that the project is substantially complete. Provide a detailed punch list of items not yet in conformance with the contract documents which require attention.

2. Submit preliminary copies of the Operation and Maintenance Manuals.
 3. Submit the as-built drawings.
 4. Submit warranties, workmanship/maintenance bonds, maintenance agreements, final certifications, and similar documents.
 5. Obtain and submit releases enabling Owner's full and unrestricted use of the work and access to services and utilities, including occupancy permits, operating certifications, and similar releases.
 6. The Contractor shall have completed all commissioning requirements in Division 21, 22, 23 and 26 except Functional Performance Testing of systems.
 7. The Contractor shall have completed all training required for Owner's staff.
 8. Submit a letter to the Architect requesting inspection and the Certificate of Substantial Completion, which will be signed and submitted to the Owner.
- E. Functional Completion
1. The Construction Manager shall submit commissioning acceptance procedures test check-off sheets, signed by the Commissioning Agent, and the Commissioning Agent's letter recommending Functional Completion.
 2. Formal records of all test procedures and results shall be included, as specified, in binders organized for convenient future reference by the Owner's operations staff.
 3. The Commissioning Agent will submit a final commissioning report recommending Function Completion when all requirements have been met and when the final report is accepted by the Client. The Commissioning Agent's report will be a comprehensive summary regarding the commissioning program, which shall also include formal records and data accumulated by the Commissioning Agent during the commissioning process.
 4. All Contractors shall participate in assisting the commissioning agent in indicating system compliance by performance ALL system tests to the satisfaction of the commissioning agent.
- F. Final Completion And Final Acceptance
1. Final Completion occurs when the work is fully and finally completed in accordance with the Contract Documents and all deficiencies have been corrected. Final Acceptance is the written acceptance issued to the Contractor by the Construction Manager and Owner after the Contractor has achieved Final Completion. The specific requirements are:
 - a. Submit "Consent of Surety to Final Payment". This letter is to be completed by the surety and mailed to the Owner.
 - b. Submit final payment request with final releases and supporting documentation not previously submitted or accepted.
 - c. Submit a copy of the Architect's final punch list of itemized work to be completed or corrected, stating that each item is complete (or otherwise resolved) for acceptance, endorsed and dated by the Architect.
 - d. Deliver tools, spare parts, extra stock of materials, and similar physical items to the Owner.
 - e. Make the final change-over of locks and transmit the new keys to the Owner. Return any loaned construction access keys. Advise Owner's personnel regarding change-over in security provisions.
 - f. Discontinue and remove from the project site temporary facilities and services, along with construction tools and facilities, mock-ups, and similar elements.
 - g. Complete final cleaning requirements, including touch-up of marred surfaces, and repair, restore and touch-up exposed finishes.

- h. Submit a letter to the Architect requesting inspection and the Certificate of Final Acceptance, which will be signed and submitted to the Owner.
- G. Commissioning Schedule
1. The Construction Managers schedule for construction, control implementation and completion, start, and point-by-point checkout must be complete for Owner occupancy, in accordance with the Construction Managers schedule.
- H. Responsibilities
1. The Contractors shall cooperate with the Construction Manager and Commissioning Agent to accomplish the following tasks:
 - a. Review and approve all functional performance tests, results, and documentation required by the contract documents, for all equipment and systems, as performed by subcontractors, vendors, etc.
 - b. Develop schedules for all testing, integrate testing into the master construction activity schedule and coordinate all subcontractor testing as required.
 - c. Assist and participate in all equipment tests, system functional tests, and cross system functional tests. Test procedures shall be in accordance with equipment manufacturer's recommendations, where applicable. Test procedures shall fully describe system configuration and steps required for each test, appropriately documented so that another party can repeat the tests with virtually identical results.
 - d. Submit test procedure schedule, procedures, forms and other documentation to the Construction Manager and Owner for approval three months prior to starting any testing required and stipulated by the construction Manager.
 - e. Coordinate directly with subcontractor on the project specific to their responsibilities and contractual obligations.
 - f. Provide qualified personnel for participation in commissioning tests, including seasonal testing required after the initial commissioning.
 - g. Provide engineering and technical expertise to oversee and direct the correction of deficiencies found during the commissioning process.
 - h. Provide all start-up and initial testing of all systems and equipment by the Contractor and subcontractors, and then all final tests of equipment and systems in accordance with the Commissioning Agent procedures.
 - i. Manage all cross system testing such as HVAC, building fire alarm, emergency power, life safety, elevators, etc.
 - j. Note any inconsistencies or deficiencies in system operations and enforce system compliance or recommend to the Architect modifications to system design which will enhance system performance.
 - 1) Coordinate with the Commissioning Agent and Construction Manager the required A/E and Owner testing participation and approval procedures, after verifying that pretests have been satisfactorily conducted and final testes are ready to be performed.
 - 2) In the event that a functional test fails, the cause of failure shall be determined and rectified as soon as possible, and then retested. If more than three functional tests of the same system(s) are required, the Contractor shall reimburse all associated costs for the extraordinary participation of the A/E, Commissioning Agent, Construction Manager and Owner's staff, as required by the particular test being performed.

- 3) Review operation and maintenance information and as-built drawings provided by the various subcontractors and vendors for verification, organization and distribution.
- 4) Obtain all documentation from tests and assemble a final test report to be submitted to the Construction Manager, Commissioning Agent, Architect and the Owner for approval.
- 5) Oversee and/or provide training for the systems specified in the Division with coordination by the Division 23 Subcontractors.

I. Related Work

1. All start-up and testing procedures and documentation requirements specified within Divisions 21, 22, 23 and 26.
2. The Test, Adjust and Balance (TAB) firm shall provided the following:
 - a. Allow sufficient time before final commissioning dates so that testing, adjusting and balancing can be accomplished.
 - b. Put all heating, ventilating and air conditioning equipment and systems into full operation and continue the operation during each working day of testing, adjusting and balancing and commissioning so they are fully functional. This includes the complete installation of all equipment, materials, pipe, duct, wire, insulation, controls, etc., per the contract documents and related directives, clarifications, change orders, etc.
3. A commissioning plan will be developed by the Commissioning Agent. Divisions, 21, 22, 23 and 26 are obligated to assist the Commissioning Agent in preparing the commissioning plan by providing all necessary information pertaining to the actual equipment and installation. If system modifications/clarifications are in the contractual requirements of this and related sections of work, they will be made at no additional cost to the Owner. If Contractor initiated system changes have been made that alter the commissioning process, the Test Engineer will notify the Commissioning Agent and Owner's Representative for approval.
4. Normal start-up services required to bring each system into a fully operational state. This includes cleaning, filling, purging, leak testing, motor rotation check, control sequences of operation, full and part load performance, etc. The TAB firm will not begin the TAB work until each system is complete, including normal contractor start-up. The Commissioning Agent will not begin the commissioning process until each system is complete, including normal contractor start-up and the TAB work has been completed.
5. Provide labor and material to make corrections when required, without undue delay.
6. The HVAC Contractor shall include the cost of exchanged sheaves and belts as may be required by the TAB firm.
7. Provide test holes in ducts and plenums where directed or necessary for pitot tubes to take air measurements and to balance the air systems. Test holes shall be provided with an approved removable plug or seal. At each location where ducts or plenums are insulated, test holes shall be provided with an approved extension with plug fitting.
8. Provide pressure and temperature taps as indicated on construction documents in locations as required by the TAB firm to adequately test and/or balance the hydronic systems.
9. The Contractor shall include a minimum of two week "flush out" period, in which the air handling systems are sequenced into a 100% outside air mode, to assist in the removal of any construction material off-gasing, in accordance with LEEDS.

- J. Test Equipment
 - 1. Provide test equipment as necessary for start-up and commissioning of the mechanical equipment and systems. The TAB firm will provide the test equipment required to perform their service.
- K. Test Equipment - Proprietary
 - 1. Proprietary test equipment required by the manufacturer, whether specified or not, shall be provided by the manufacturer of the equipment. Manufacturer shall provide the test equipment, demonstrate its use, and assist the Commissioning Test Engineer in the commissioning process. Proprietary test equipment shall become the property of the Owner upon completion of commissioning.
 - 2. Identify the proprietary test equipment required in the test procedures submittals and in a separate list of equipment to be included in the operations and maintenance manuals.
- L. Work Prior To Commissioning
 - 1. Complete all phases of work so the system can be started, tested, adjusted, balanced, controlled and otherwise commissioned. Divisions 21, 22, 23 and 26 have primary start-up responsibilities with obligations to complete systems, including all sub-systems completion will not relieve these Divisions from completing those systems as per the Construction and Commissioning schedule.
- M. Work To Resolve Deficiencies
 - 1. In some systems, mis-adjustments, misapplied equipment and/or deficient performance under varying loads will result in additional work being required by the Contractors to commission the systems. This work will be completed under the direction of the Construction Manager, Architect and Owner's Representative, with input from the Contractor, equipment supplier, and Commissioning Agent. Whereas all members will have input and the opportunity to discuss the work and resolve problems, the Architect will have final jurisdiction on the necessary work to be done to achieve performance.
 - 2. Corrective work shall be completed in a timely fashion to permit timely completion of the commissioning process. Experimentation to render system performance will be permitted. If the Commissioning Agent deems the experimentation work to be ineffective or untimely as it relates to the commissioning process, the Commissioning Agent will notify the Owner indicating the nature of the problem, expected steps to be taken, and the deadline for completion of activities. If deadlines pass without resolution of the problem, the Owner reserves the right to obtain supplementary services and/or equipment to resolve the problem. Costs incurred to solve the problems in an expeditious manner will be the Contractor's responsibility.
- N. Seasonal Commissioning And Occupancy Variations
 - 1. Seasonal commissioning pertains to testing under full-load conditions during peak heating and peak cooling seasons, as well as part-load conditions in the spring and fall. Initial commissioning will be done as soon as contract work is completed regardless of season. Subsequent commissioning may be undertaken at any time thereafter to ascertain adequate performance during the different seasons.
 - 2. All equipment and systems will be tested and commissioned in a peak season to observe full-load performance. Heating equipment will be tested during winter design extremes. Cooling equipment will be tested during summer design extremes, with a fully occupied building. Each Contractor and supplier

- will be responsible to participate in the initial and the alternate peak season test of the systems required to demonstrate performance, as scheduled by the Commission Agent, with three day (minimum) advance notification.
3. Subsequent commissioning may be required under conditions of minimum and/or maximum occupancy or use. All equipment and systems affected by occupancy variations will be tested and commissioned at the minimum and peak loads to observe system performance. The Contractor will be responsible to participate in the occupancy sensitive testing of systems to provide verification of adequate performance.
- O. Recommissioning
1. Upon notification by the Commissioning Agent of successful system/equipment performance/checkout test, the Owner shall witness Test No. 1. If any system/equipment/component/device fails to perform correctly during Test No. 1, the Contractor and/or equipment supplier must correct any systems/wiring deficiencies, and must incur any travel/airfares/food/hotel expenses of the designated Agent, to be available for the Retest No. 1.
- P. Training
1. Participate in the training of the Owner's engineering and maintenance staff, as required in Divisions 01, 21, 22, 23 and 26, on each system and related components. Training, in part, will be conducted in a classroom setting, with system and component documentation, and suitable classroom training aids.
 2. Training will be conducted jointly by the Commissioning Agent, the Contractor, and the equipment vendors. The Test Engineer will be responsible for highlighting system peculiarities specific to this project.
- Q. Systems Documentation
1. In addition to the requirements of Division 01, The Contractor shall update contract documents to incorporate field changes and revisions to system designs to account for actual constructed configurations. All drawings shall be red-lined on two sets. Divisions 21, 22, 23 and 26 as-built drawings shall include architectural floor plans, elevations, and details, and the individual mechanical or electrical systems in relation to actual building layout.
 2. Maintain as-built red-lines as required by Division 01. Given the size and complexity of this project, red-line drawings at completion of construction, based on memory of key personnel, is not satisfactory. Continuous and regular red-lining of drawings is considered essential and mandatory.
- R. Miscellaneous Support
1. Divisions 21, 22, 23 and 26 shall remove and replace covers of mechanical equipment, open access panels, etc., to permit the Commissioning Agent, Architect and Owner's representative to observe equipment and controllers provided. Furnish ladders and flashlights as necessary.
- S. Systems To Be Commissioned
1. HVAC
 - a. Each exhaust fan.
 - b. Each supply fan.
 - c. Each return fan.
 - d. Each supply air unit including verification of all air and water flows at each coil and filter.
 - e. Each air flow station.
 - f. Each Variable Frequency Drive.
 - g. Cabinet and unit heaters.
 - h. Each water flow measuring station/flow meter.

- i. Each DDC terminal box and induction box.
 - j. Each Circulating Pump.
 - k. Tele/Data A.C.System.
 - l. Verify the final accuracy of the air and water test and balancing report.
 - m. Verify the air distribution of the operating rooms system for both summer and winter operations. (temperature, humidity and pressurization)
 - n. BMS functional and operational control sequences.
 - o. Moisture sensor system at drain pans.
 - p. Each individual lighting control interface.
 - q. Each kilowatt metering interface.
 2. Plumbing/Fire Protection
 - a. Domestic Water Heaters (Potable).
 - b. Each alarm valve.
 - c. Flow Restriction Devices
 - d. Reduced Pressure Backflow Devices
 3. Electrical
 - a. Circuit breaker trip setting verification.
 - b. Lighting controls.
 - c. Fire alarm interface to HVAC/ATC.
 - d. Security interface.
 - e. Elevator fire alarm control system.
 - f. Emergency Power
- T. Post Occupancy Commissioning
 1. This Contractor shall fully cooperate in all regards with this phase of commissioning.
 2. The Commissioning Agent will prepare a complete building operations review within ten (10) months after substantial completion with the owners operating personnel and note in the report any outstanding construction and/or operational deficiencies that are identified during this post occupancy review. This report shall be provided to the owner, Construction Manager and A/E. This Post-Occupancy deficiency list shall be corrected by the Construction Manager under the one year guarantee/warranty period and shall be submitted as being completed by the Contractor and Equipment Suppliers. The Commissioning Agent shall also procure all equipment manufacturer test data verifying post-occupancy equipment efficiencies and compare all such data to the information published by the manufacturer. This data shall be used to verify overall equipment efficiency against the contract specifications.
 3. Divisions 21, 22, 23 and 26 shall correct any and all system deficiencies noted by the Commissioning Agent during the first one year after substantial completion and as noted by the Commissioning Agent during the 10th month building operating review.
- U. LEED Point Initiative
 1. It is the intent of the Owner to install, test, commission and operate the building systems in accordance with USGBC LEED-NC for new construction. This contractor shall be responsible for all submittal data, testing, flush-out, reporting and verification necessary during the construction, close-out and post commissioning to comply with the following USGBC LEED credits for HVAC systems:
 - a. Energy and Atmosphere Credit 3- Cooperation and Documentation for Enhanced Commissioning and Credit 5-Measurement and Verification Documentation.

- b. Indoor Environmental Quality Credits 1- Outdoor Air Delivery Monitoring, Credit 3.2- Construction IAQ Management Plan (Before Occupancy), Credit 4.1- Low-Emitting Materials (Adhesive and Sealants), Credit 5- Indoor Chemical and Pollutant Source Control and Credit 7.2- Thermal Comfort Verification.

PART 2 - PRODUCTS

2.1 BASE BID MANUFACTURERS

- A. Base bid on materials or equipment are specified by name of manufacturer, brand or trade name and catalog reference.
- B. The choice will be optional with bidder where two or more manufacturers are named.
- C. The following are base bid manufacturers for items under this Section:
 - 1. Access doors: Karp Associates, Inc., Higgins Mfg. Co., Milcor Steel Co., and Walsh-Spencer Co.
 - 2. Inserts: F and S Mfg Co., Fee and Mason and Grinnell.
 - 3. Hangers and supports: I.T.T. Grinnell, Carpenter and Patterson, Inc., and Fee & Mason.
 - 4. Paint: Sherwin-Williams, Pittsburgh Paint Co., Pratt and Lambert, and Rust-Oleum.
 - 5. Gratings: Irving Grating IKG Industries and Ryerson - Inland Steel Co.

2.2 INSERTS AND SUPPORTS

- A. Support all HVAC work from building construction by providing inserts, beam clamps, steel fishplates (in concrete fill only), and acceptable brackets. Submit all methods for review.
- B. Provide trapeze hangers of bolted angles or channels for grouped lines and services.
- C. Provide additional framing where building construction is inadequate. Submit for review.
- D. Inserts shall be steel, slotted type and factory-painted.
 - 1. Single rod shall be similar to Grinnell Fig. 281.
 - 2. Multi-rod shall be similar to Fee & Mason Series 9000 with end caps and closure strips.
 - 3. Clip form nails flush with inserts.
 - 4. Maximum loading including pipe, contents and covering shall not exceed 75 percent of rated insert capability.
- E. Supports from steel decks:
 - 1. Pipes:
 - a. Sizes up to 3" diameter maximum hanger spacing: 10' centers maximum.
 - b. Beyond 3" diameter provide support steel, hanger spacing: 10' centers.
 - 2. Ductwork:
 - a. Hangers spacing: maximum 10' centers and/or every change in direction.

2.3 SUPPLEMENTARY STEEL, CHANNELS AND SUPPORTS:

- A. Furnish supplementary steel, channels and supports required for proper installation, mounting and support of all HVAC work.
- B. Connect supplementary steel and channels firmly to building construction in an acceptable manner.
- C. Determine type and size of supporting channels and supplementary steel. Supplementary steel and channels shall be of sufficient strength and size to allow only a minimum deflection in conformance with manufacturer's requirements of loading.
- D. Install supplementary steel and channels in a neat and workmanlike manner parallel to walls, floors, and ceiling construction.
- E. All supplementary steel, channels, supports shall be submitted to Structural Engineer for review.

2.4 EXPANSION ANCHORS

- A. Provide smooth wall, non-self-drilling internal plug expansion type anchors constructed of AISC 12L14 steel and zinc plated in accordance with Fed. Spec. QQ-A-325 Type 1, Class 3.
- B. Do not exceed 1/4 of average values for a specific anchor size using 2000 psig (13,800 kpa) concrete only, for maximum working load.
- C. Provide spacing and install anchors in accordance with manufacturer's recommendations.

2.5 ACCESS DOORS

- A. This contractor shall submit to the architect for approval a plan indicating the size (minimum 18" x 18") and location of all building construction access doors required for operation and maintenance of all concealed equipment, devices, valves, dampers and controls. Contractor shall arrange for furnishing of all access doors in finished construction and include costs in the bid.
- B. Flush type access doors shall be similar to Karp Type DSC-211 with No. 13 USSG steel doors and trim and No. 16 USSG steel frame, metal wings for keying into construction, concealed hinges and screwdriver operated stainless steel cam lock. Provide lift off type access doors, similar to Karp Type DSC-212, where door cannot swing open.
- C. In acoustic tile ceilings, factory finished white access doors shall be similar to Karp Type DSC-210, with No. 13 USSG steel frame, No. 16 USSG steel pan door suitable for receiving tile thickness and hinges that are not visible when door is closed. Access door shall have screwdriver operated stainless steel cam locks finishing flush with tile with a minimum of 2 per door.
- D. In plaster ceilings recessed access doors shall be similar to Karp DSC-210-PL, with recess to receive plaster.
- E. In fire rated construction provide fire rated access doors, similar to Karp KRP-150-FR, in accordance with applicable code requirements.
- F. Access doors shall have one coat of shop-painted zinc chromate primer.

2.6 ACCESS TILE IDENTIFICATION:

- A. In removable ceiling tiles, provide buttons, tabs, and markers to identify location of concealed work. Submit for review.

2.7 EQUIPMENT PLATFORMS

- A. Equipment platforms will be provided under General Construction Work.

2.8 LADDERS

- A. Ladders will be provided under General Construction Work except those inside air handling units which shall be provided as an integral part of the unit.

2.9 SHAFT GRATINGS

- A. Shaft gratings will be provided under General Construction Work.

2.10 TAGS:

- A. Provide 2 in. round valve tags on all valves and controls of No. 18 BS gauge aluminum with stamped numbers and letters filled in with black paint.
- B. Indicate identifying number and system letter on tags, and fasten by heavy aluminum or brass "S" hooks or chains.
- C. Tags shall be similar to Seton Name Plate Corporation.

2.11 CHARTS

- A. Provide valve tag chart indicating valve number, system, type, size, location and function for all valves.
- B. Mount in aluminum frame and glass.
- C. Letter and number valves and controls to correspond with designations on metal tags.
- D. Fasten charts permanently in locations, as directed, with four brass screws.

2.12 NAMEPLATES

- A. Provide nameplates with inscriptions, subject to review, indicating building abbreviations, equipment number and capacity (CFM and/or GPM). Fasten with epoxy cement or chrome plated screws. Nameplate shall be black Lamicoid sheet with white lettering.

PART 3 - EXECUTION

3.1 MECHANICAL IDENTIFICATION

- A. Refer to identification Section.

3.2 FOUNDATIONS

- A. Foundations and concrete will be provided under General Construction Work.
- B. Coordinate foundations for:
 - 1. Pumps.
 - 2. Fans.
 - 3. Air handling units and floor mounted plenums.
 - 4. Floor mounted control panels.
 - 5. Motor controllers; VFD's, Disconnect Switches, etc.
 - 6. Motors.
 - 7. Air cooled chillers and/or compressor/condensers units.
 - 8. Control Panels.
 - 9. Boilers
 - 10. Vertical Stacks.

3.3 WATERPROOFING

- A. Waterproofing will be provided under General Construction Work.

3.4 FIELD QUALITY CONTROL

- A. Perform tests as noted, and in the presence of Architect and/or Construction Manager, Engineer and authorities having jurisdiction.
- B. Provide required labor, material, equipment, and connections necessary for tests and submit results for review.
- C. Repair or replace defective work and pay for restoring or replacing damaged work due to tests, as directed.

3.5 CLEANING

- A. Brush and clean work prior to concealing, painting and acceptance. Perform in stages if directed.
- B. Clean and repair painted exposed work, soiled or damaged, to match adjoining work before final acceptance.
- C. Remove debris from inside and outside of material and equipment.

END OF SECTION

SECTION 23 00 01

SUPPLEMENTARY CONDITIONS FOR MECHANICAL, ELECTRICAL, PLUMBING AND FIRE PROTECTION WORK

PART 1 - GENERAL

- 1.1 The "GENERAL CONDITIONS OF THE CONTRACT FOR CONSTRUCTION", AIA Document A201-2007, is part of this Contract.
- 1.2 SUMMARY
 - A. Sustainable Building Requirements:
 - 1. The Owner requires the Contractor to implement practices and procedures to meet the project's environmental performance goals, which include achieving LEED version 4 **Certified** level Certification. Specific project goals that may impact this area of work include: use of recycled-content materials; use of locally-manufactured materials; use of low-emitting materials; construction waste recycling; and the implementation of a construction indoor air quality management plan. The Contractor shall ensure that the requirements related to these goals, as defined in the Articles below, are implemented to the fullest extent. Substitutions, or other changes to the work proposed by the Contractor or their Subcontractors, shall not be allowed if such changes compromise the aforementioned environmental goals and LEED certification.
- 1.3 SUPPLEMENTARY CONDITIONS
 - A. These SUPPLEMENTARY CONDITIONS amend or supplement the GENERAL CONDITIONS and other provisions of the Contract Documents as indicated below. All provisions which are not so amended or supplemented remain in full force and effect. AIA document A201-2007 Edition is referenced
- 1.4 GENERAL PROVISIONS
 - A. THE SPECIFICATIONS
 - B. For additional definitions, see "General Provisions" section of each trade.
 - C. CORRELATION AND INTENT OF CONTRACT DOCUMENTS
 - D. No reassignment of division of responsibility for work as specified for the respective trades shall be made without prior written acceptance by Engineer.
- 1.5 CONTRACTOR
 - A. SUPERINTENDENT

- B. Contractor shall arrange for Subcontractors for Heating, Ventilation and Air Conditioning work, Electrical Work, Fire Protection Work, Plumbing Work, or any other division of work, to each supply services of a competent project manager who shall act as assistants to the Superintendent and who shall be in attendance at the Project site during the progress of the Work. Such project managers shall be satisfactory to the Engineer, and shall not be changed except with the consent of the Architect
- C. DOCUMENTS AND SAMPLES AT THE SITE
- D. Dimension underground utilities from permanent identifiable benchmarks on Record Drawings.

- E. RECORD DRAWINGS
- F. Before commencing work, procure complete reproducible set of Contract Drawings.
- G. Conspicuously indicate major deviations in Mechanical Equipment Rooms by specific reference to shop drawings of these rooms and submit reproducibles of such shop drawings.
- H. Submit up-to-date "in progress" prints, to Architect when requesting 25 percent, 50 percent, 75 percent and 95 percent payment of work installed.
- I. Upon completion of work, submit signed certified reproducibles of Record and reference shop drawings, along with marked-up prints of in-progress drawing to Architect for acceptance. Also provide an electronic version of the as-built drawings using Auto CADD
- J. SHOP DRAWINGS, PRODUCT DATA AND SAMPLES
- K. Any Shop Drawing, Product Data or Sample submitted without Contractor's approval will not be processed for approval by the Architect, but will be returned to the Contractor for his compliance with the above procedures, in which event it will be deemed that the Contractor has not complied with the provisions herein specified and the Contractor shall bear risk of all delays as if no Shop Drawing, Product Data or Sample had been submitted
- L. Shop Drawings, Product Data, and Samples shall include complete dimensional accuracy; the Contractor shall verify that he has checked to insure that work contiguous with and having bearing on the work shown on the Shop Drawings is accurately and clearly shown, that he has checked the Shop Drawings against the Composite Drawings prepared by the Contractor, and that the work has been coordinated and that the equipment will fit into the assigned spaces
- M. Prior to shop drawings and sample submissions, and within 30 days after award of contract, submit lists of proposed manufacturers names, shop drawings and samples with proposed schedule of submission dates referenced by Specification Section, Article Numbers and Contract Drawing Number. Contractor shall be responsible for any delays resulting from failure to submit such lists
- N. Submit shop drawings and samples for materials, equipment and systems as noted in each respective specification section for each trade
- O. Any construction and/or design changes as a result of any approved substitution shall be made at no additional cost to the Owner
- P. Composite Drawings:
- Q. In the interest of coordination and to expedite the work in critical areas, the Contractor shall prepare and submit, to the Architect for review, Composite Drawings incorporating the work of the various trades and/or subcontractor involved. After review, the Contractor shall distribute prints of reviewed Composite Drawings to affected trades and/or subcontractors. The Contractor

shall require that the involved trades and/or subcontractors cooperate in preparation of the Composite Drawings to assure proper coordination between trades and/or subcontractors. The participating parties shall indicate their approval on these drawings, in addition to the Contractor

- R. Provide composite shop drawings 3/8 inch per foot scale or as approved of areas where contractors proposed installation is at variance with the Contract Drawings or Specifications. Ductwork, piping layout and distribution drawings are required for all below listed specific areas
- S. Equipment Rooms
- T. Plenums
- U. Shafts
- V. Roof Level
- W. All Floors
- X. Indicate dimensioned layouts, elevations and sections of the following, on composite shop drawings
- Y. Piping and valves
- Z. Raceways
- AA. Pull boxes
- BB. Lighting
- CC. Equipment
- DD. Connections
- EE. Access for servicing
- FF. Building construction (floor, ceiling, beams and columns)
- GG. Plan work to allow sufficient time for coordination and for compliance with construction schedule
- HH. Catalog, model and serial numbers will be assumed to represent equipment complying with Contract Drawings and Specifications, unless otherwise noted
- II. Submit additional shop drawings (other than noted) when directed, during progress of project
- JJ. Shop drawing resubmissions are required within 30 days of receipt of review comments from Architect

- KK. Replace all material and equipment which was installed prior to shop drawing review when directed by Architect
- LL. Before submitting shop drawings and samples, check material and equipment against drawings for clearance, connections, accessibility, servicing and maintenance
- MM. Submit shop drawings with:
- NN. Marked notation of any deviations from the Contract Documents and reasons for same. Indicate such deviations in a conspicuous manner including component, material and system variations, additions and deletions revised equipment locations, hung ceiling heights and headroom conditions
- OO. Manufacturer's specifications including: materials, type, performance characteristics, voltage, phase and capacity. Specifications for project shall be tailored to reflect the requirements of the contract documents
- PP. Certified dimensional drawings, indicating sizes, component parts and installation details
- QQ. Wiring diagrams when applicable
- RR. Identify with:
 - a. Project name and number.
 - b. Names of Architect and Engineer.
 - c. Identification of applicable items on each submission.
 - d. Applicable Contract Specification Section and Article Numbers.
 - e. Applicable Contract Drawing Numbers.
- SS. Minimum copies of shop drawing submissions:
- TT. 8-1/2 inch by 14 inch and smaller: Eight (8) copies
- UU. Larger than 8-1/2 inch by 14 inch: 1 reproducible plus eight (8) print
- VV. All fire walls and smoke partitions must be highlighted on the sheet metal drawings for appropriate coordination
- WW. CLEANING UP
- XX. Remove broken or scratched glass and replace with new glass, remove paint drippings, spots, stains, and dirt from finished surfaces and clean fixtures, hardware, floors and equipment. Contractor shall keep interior of the building free of stored or unattended combustible material
- YY. INDEMNIFICATION

ZZ. Relieve Owner of all claims in connection with use of facilities, conveniences or services supplied by other parties

AAA. ADMINISTRATION OF THE CONTRACT

BBB. ARCHITECT

1. Whenever the word "Architect" occurs, the word "Engineer" shall be also stipulated, and shall mean the firm of AKF Group, LLC or its authorized representative

CCC. PROTECTION OF PERSONS AND PROPERTY

DDD. SAFETY OF PERSONS AND PROPERTY

EEE. Close open ends of work with temporary covers or plugs during construction to prevent entry of obstructing materials

FFF. Storage areas will be designated by Architect or Building Owner

GGG. PARTIAL OCCUPANCY OR USE

HHH. No equipment intended for permanent installation shall be operated for temporary purposes without written permission of, and complete agreement with stipulation as set forth by, the Architect

III. DEVIATIONS

JJJ. When deviations to Contract Documents are requested by the Contractor and accepted by the Architect, Contractor shall be responsible for all affected work and costs, including that of other contracts.

KKK. Interference with Owner's Operations

LLL. Contractors shall take whatever action is necessary to avoid interference with owner's use of the building or damage to existing facilities equipment

MMM. Except as otherwise specified herein, contractors may work during normal working hours. In the event that noisy work interferes with owner's operations, owner may direct contractor to stop that work. If the workers involved cannot be used on other work, Contractor shall be paid for the lost time in accordance with a schedule of hourly rates to be included in the contract. Owner's representative will determine the duration of the stoppage and whether compensation therefor is warranted

NNN. Contractor shall include with his proposal a schedule of hourly rates and overtime premiums

OOO. Maintain all existing site utility and building services in operation

PPP. PROJECT CLOSEOUT PROCEDURES

QQQ. The requirements of this section are in addition to and supplement the requirements outlined in Division 1

RRR. It shall be each contractor's responsibility to personally hand-deliver all of the required project closeout checklist items and to obtain Owner's authorized representative(s) signed receipt on all items requiring Owner sign-off

SSS. Project Closeout Checklist

TTT. Review requirements of each section of the specifications and submit for approval to Architect the sign-off forms which shall become the project closeout checklist. These, at a minimum, shall include the following information shown in attached Project Closeout Checklist Example. The Architect and/or Owner may incorporate additional specific items to the following checklist which shall become part of the project requirements

UUU. Closeout Checklist Example:

PART 2 - PROJECT CLOSETOUT			
PART 3 - PROJECT:			
PART 4 - DIVISION NO.:			
PART 5 - CONTRACTOR:			
PART 6 - ITEM ¹	PART 7 - DATES		PART 8 - OWNER'S SIGN-OFF
	PART 9 - COMPLETED	PART 10 - RECEIVED BY OWNER	
PART 11 - Permits	PART 12 -	PART 13 -	PART 14 -
PART 15 - City and State Inspection	PART 16 -	PART 17 -	PART 18 -
PART 19 - Manufacturer's warranties	PART 20 -	PART 21 -	PART 22 -
PART 23 - Contractor's Warranties	PART 24 -	PART 25 -	PART 26 -
PART 27 - State Fire Rating Data	PART 28 -	PART 29 -	PART 30 -
PART 31 - Copy of Final Shop Drawings	PART 32 -	PART 33 -	PART 34 -
PART 35 - List and Possession of Spare Parts	PART 36 -	PART 37 -	PART 38 -
PART 39 - Pressure Tests (Ductwork)	PART 40 -	PART 41 -	PART 42 -
PART 43 - Pressure Tests (Piping)	PART 44 -	PART 45 -	PART 46 -
PART 47 - Equipment Tests Required by Specs	PART 48 -	PART 49 -	PART 50 -
PART 51 - O & M Manuals	PART 52 -	PART 53 -	PART 54 -
PART 55 - Record Documents	PART 56 -	PART 57 -	PART 58 -
PART 59 - Coordination Drawings	PART 60 -	PART 61 -	PART 62 -
PART 63 - Sanitization Reports	PART 64 -	PART 65 -	PART 66 -

PART 2 - PROJECT CLOSETOUT			
PART 3 - PROJECT:			
PART 4 - DIVISION NO.:			
PART 5 - CONTRACTOR:			
PART 67 - Commissioning and LEED® Reports/Letters/Forms	PART 68 -	PART 69 -	PART 70 -
PART 71 - On-Site Training Complete	PART 72 -	PART 73 -	PART 74 -
PART 75 - Protective Device Settings	PART 76 -	PART 77 -	PART 78 -
PART 79 - Valve Tags and Charts	PART 80 -	PART 81 -	PART 82 -
PART 83 - Final BMS Installation Drawings	PART 84 -	PART 85 -	PART 86 -
PART 87 - Insurance Underwriters Approvals	PART 88 -	PART 89 -	PART 90 -
PART 91 - Final Punch List (Initialed by contractor that items are complete)	PART 92 -	PART 93 -	PART 94 -
PART 95 - Building Certificate of Occupancy (C.O.)	PART 96 -	PART 97 -	PART 98 -
PART 99 - 24-Hour Phone No. for Service During Guarantee Period	PART 100 -	PART 101 -	PART 102 -

Part 2- PRODUCTS

(Not Applicable)

Part 3- EXECUTION

(Not Applicable)

END OF SECTION

SECTION 23 05 00

COMMON WORK RESULTS FOR HVAC

PART 1 - GENERAL

1.1 RELATED DOCUMENTS

- A. Drawings and general provisions of the Contract, including General and Supplementary Conditions and Division 01 Specification Sections, apply to this Section.
- B. Section 01 81 13 "Sustainable Design Requirements – LEED v4 for Building Design & Construction – New Construction" for sustainable design requirements and detailed sustainable design submittal requirements.
- C. Section 01 74 19 "Construction and Demolition Waste Management and Disposal" for disposal of construction, demolition and packaging waste disposal requirements.

1.2 SUMMARY

- A. This Section includes the following:
 - 1. Piping materials and installation instructions common to most piping systems.
 - 2. Transition fittings.
 - 3. Dielectric fittings.
 - 4. Mechanical sleeve seals.
 - 5. Sleeves.
 - 6. Escutcheons.
 - 7. Grout.
 - 8. Equipment installation requirements common to equipment sections.
 - 9. Painting and finishing.
 - 10. Concrete bases.
 - 11. Supports and anchorages.
- B. Sustainable Building Requirements:
 - 1. The Owner requires the Contractor to implement practices and procedures to meet the project's environmental performance goals, which include achieving LEED version 4 **Certified** level Certification. Specific project goals that may impact this area of work include: use of recycled-content materials; use of locally-manufactured materials; use of low-emitting materials; construction waste recycling; and the implementation of a construction indoor air quality management plan. The Contractor shall ensure that the requirements related to these goals, as defined in the Articles below, are implemented to the fullest extent. Substitutions, or other changes to the work proposed by the Contractor or their Subcontractors, shall not be allowed if such changes compromise the aforementioned environmental goals and LEED certification.

1.3 DEFINITIONS

- A. Finished Spaces: Spaces other than mechanical and electrical equipment rooms, furred spaces, pipe and duct chases, unheated spaces immediately below roof, spaces above ceilings, unexcavated spaces, crawlspaces, and tunnels.
- B. Exposed, Interior Installations: Exposed to view indoors. Examples include finished occupied spaces and mechanical equipment rooms.
- C. Exposed, Exterior Installations: Exposed to view outdoors or subject to outdoor ambient temperatures and weather conditions. Examples include rooftop locations.
- D. Concealed, Interior Installations: Concealed from view and protected from physical contact by building occupants. Examples include above ceilings and chases.
- E. Concealed, Exterior Installations: Concealed from view and protected from weather conditions and physical contact by building occupants but subject to outdoor ambient temperatures. Examples include installations within unheated shelters.
- F. The following are industry abbreviations for plastic materials:
 - 1. CPVC: Chlorinated polyvinyl chloride plastic.
 - 2. PE: Polyethylene plastic.
 - 3. PVC: Polyvinyl chloride plastic.
- G. The following are industry abbreviations for rubber materials:
 - 1. EPDM: Ethylene-propylene-diene terpolymer rubber.
 - 2. NBR: Acrylonitrile-butadiene rubber.

1.4 SUBMITTALS

- A. Product Data: For the following:
 - 1. Transition fittings.
 - 2. Dielectric fittings.
 - 3. Mechanical sleeve seals.
 - 4. Escutcheons.
- B. Welding certificates
- C. Welding: Before proceeding, submit the following for review and approval;
 - 1. Proposed procedure conforming to latest revision of:
 - a. ANSI/ASME B31.1, Pressure Piping Chapter V.
 - b. ANSI/ASME B31.9, Building Services Piping
 - c. ANSI 249.1 Safety in Welding and Cutting
 - 2. List of welders qualified per section IX of ASME. Boiler and Pressure Vessel Code including, but not limited to, the following information:
 - a. Welder's name
 - b. Welder's Social Security Number
 - c. Employer's name
 - d. Name of testing laboratory
 - e. Procedure tested for including, but not limited to, the following:
 - 1) Date of test
 - 2) Wall thickness
 - 3) Base metal material
 - 4) Electrode
 - 5) Position
 - f. Procedure tested for including, but not limited to, the following:
 - 1) Type of test performed

- 2) Result of test
 - 3) Welder's identification symbol
 - 4) Sample of each identification device
 - 5) Certify that each welder has either worked in the procedure or successfully tested in the procedure within the past six month
3. No reports from any welding inspection agency shall be accepted unless each agency has first requested and obtained qualifications from the office in accordance with rule 16-1 of the Board of Standards and Appeals welding rule.
- D. Brazing: Before proceeding, submit the following for review and approval;
1. Proposal procedure conforming to latest revision of:
 - a. Section IX, ASME Boiler and Pressure Vessel Code, Welding and Brazing Qualifications.
 - b. ANSI/AWS B2.2 Standard for Brazing Procedure and Performance Qualification
 2. List of brazers qualified per section IX of ASME. Boiler and Pressure Vessel Code including, but not limited to, the following information:
 - a. Brazer's name
 - b. Brazer's Social Security Number
 - c. Employer's name
 - d. Name of testing laboratory
 - e. Procedure tested for including, but not limited to, the following:
 - 1) Date of test
 - 2) Wall thickness
 - 3) Base metal material
 - 4) Brazing filler material
 - 5) Position
 - 6) Type of test performed
 - 7) Result of test
 - 8) Brazer's identification symbol
 - 9) Sample of each identification device
 - 10) Certify that each Brazer has either worked in the procedure or successfully tested in the procedure within the past six months

1.5 QUALITY ASSURANCE

- A. Steel Support Welding: Qualify processes and operators according to AWS D1.1, "Structural Welding Code--Steel."
- B. Steel Pipe Welding: Qualify processes and operators according to ASME Boiler and Pressure Vessel Code: Section IX, "Welding and Brazing Qualifications."
 1. Comply with provisions in ASME B31 Series, "Code for Pressure Piping."
 2. Certify that each welder has passed AWS qualification tests for welding processes involved and that certification is current.
- C. Electrical Characteristics for HVAC Equipment: Equipment of higher electrical characteristics may be furnished provided such proposed equipment is approved in writing and connecting electrical services, circuit breakers, and conduit sizes are appropriately modified. If minimum energy ratings or efficiencies are specified, equipment shall comply with requirements.

1.6 DELIVERY, STORAGE, AND HANDLING

- A. Deliver pipes and tubes with factory-applied end caps. Maintain end caps through shipping, storage, and handling to prevent pipe end damage and to prevent entrance of dirt, debris, and moisture.
- B. Store plastic pipes protected from direct sunlight. Support to prevent sagging and bending.

1.7 COORDINATION

- A. Arrange for pipe spaces, chases, slots, and openings in building structure during progress of construction, to allow for HVAC installations.
- B. Coordinate installation of required supporting devices and set sleeves in poured-in-place concrete and other structural components as they are constructed.
- C. Coordinate requirements for access panels and doors for HVAC items requiring access that are concealed behind finished surfaces. Access panels and doors are specified in Division 08 Section "Access Doors and Frames."

PART 2 - PRODUCTS

2.1 MANUFACTURERS

- A. In other Part 2 articles where subparagraph titles below introduce lists, the following requirements apply for product selection:
 - 1. Available Manufacturers: Subject to compliance with requirements, manufacturers offering products that may be incorporated into the Work include, but are not limited to, the manufacturers specified.
 - 2. Manufacturers: Subject to compliance with requirements, provide products by the manufacturers specified.

2.2 PIPE, TUBE, AND FITTINGS

- A. Refer to individual Division 23 Piping Sections for pipe, tube, and fitting materials and joining methods.
- B. Pipe Threads: ASME B1.20.1 for factory-threaded pipe and pipe fittings.

2.3 JOINING MATERIALS

- A. Refer to individual Division 23 Piping Sections for special joining materials not listed below.
- B. Pipe-Flange Gasket Materials: Suitable for chemical and thermal conditions of piping system contents.
 - 1. ASME B16.21, nonmetallic, flat, asbestos-free, 1/8-inch (3.2-mm) maximum thickness unless thickness or specific material is indicated.
 - a. Full-Face Type: For flat-face, Class 125, cast-iron and cast-bronze flanges.
 - b. Narrow-Face Type: For raised-face, Class 250, cast-iron and steel flanges.

2. AWWA C110, rubber, flat face, 1/8 inch (3.2 mm) thick, unless otherwise indicated; and full-face or ring type, unless otherwise indicated.
- C. Flange Bolts and Nuts: ASME B18.2.1, carbon steel, unless otherwise indicated.
- D. Plastic, Pipe-Flange Gasket, Bolts, and Nuts: Type and material recommended by piping system manufacturer, unless otherwise indicated.
- E. Solder Filler Metals: ASTM B 32, lead-free alloys. Include water-flushable flux according to ASTM B 813.
- F. Brazing Filler Metals: AWS A5.8, BCuP Series, copper-phosphorus alloys for general-duty brazing, unless otherwise indicated; and AWS A5.8, BAg1, silver alloy for refrigerant piping, unless otherwise indicated.
- G. Welding Filler Metals: Comply with AWS D10.12 for welding materials appropriate for wall thickness and chemical analysis of steel pipe being welded.

2.4 DIELECTRIC FITTINGS

- A. Description: Combination fitting of copper alloy and ferrous materials with threaded, solder-joint, plain, or weld-neck end connections that match piping system materials.
- B. Insulating Material: Suitable for system fluid, pressure, and temperature.
- C. Dielectric Unions: In lieu of dielectric unions, use brass unions between different pipe materials.

2.5 MECHANICAL SLEEVE SEALS

- A. Description: Modular sealing element unit, designed for field assembly, to fill annular space between pipe and sleeve.
 1. Manufacturers:
 - a. Advance Products & Systems, Inc.
 - b. Calpico, Inc.
 - c. Metraflex Co.
 - d. Pipeline Seal and Insulator, Inc.
 - e. Thunderline Link-seal
 2. Sealing Elements: NBR interlocking links shaped to fit surface of pipe. Include type and number required for pipe material and size of pipe.
 3. Pressure Plates: Stainless steel. Include two for each sealing element.
 4. Connecting Bolts and Nuts: Stainless steel of length required to secure pressure plates to sealing elements. Include one for each sealing element.

2.6 SLEEVES

- A. Galvanized-Steel Sheet: 0.0239-inch minimum thickness; round tube closed with welded longitudinal joint.
- B. Steel Pipe: ASTM A 53, Type E, Grade B, Schedule 40, galvanized, plain ends.
 1. Underdeck Clamp: Clamping ring with set screws.

2.7 ESCUTCHEONS

- A. Description: Manufactured wall and ceiling escutcheons and floor plates, with an ID to closely fit around pipe, tube, and insulation of insulated piping and an OD that completely covers opening.
- B. One-Piece, Deep-Pattern Type: Deep-drawn, box-shaped brass with polished chrome-plated finish.
- C. One-Piece, Cast-Brass Type: With set screw.
 - 1. Finish: Polished chrome-plated.
- D. Split-Casting, Cast-Brass Type: With concealed hinge and set screw.
 - 1. Finish: Polished chrome-plated.
- E. One-Piece, Stamped-Steel Type: With spring clips and chrome-plated finish.
- F. Split-Plate, Stamped-Steel Type: With concealed hinge, spring clips, and chrome-plated finish.
- G. One-Piece, Floor-Plate Type: Cast-iron floor plate.
- H. Split-Casting, Floor-Plate Type: Cast brass with concealed hinge and set screw.

2.8 GROUT

- A. General Purpose Description: ASTM C 1107, Grade B, nonshrink and nonmetallic, dry hydraulic-cement grout.
 - 1. Characteristics: Post-hardening, volume-adjusting, nonstaining, noncorrosive, nongaseous, and recommended for interior and exterior applications.
 - 2. Design Mix: 14000 / 19000-psi, 36 hours @70 degrees compressive strength.
 - 3. Packaging: factory packaged for field mixing.
- B. Pump Mounting: High flow, high strength epoxy machine-based grout: ASTM C 881, CRD-C 590.
 - 1. Characteristics: Two to Three-component, highly flowable, epoxy-based grout that produces high performance strength plus chemical inertness and excellent bonding properties.
 - 2. Design Mix: ASTM-C 579, 14,000 / 19,000 psi , 36 hours @72 degree F compressive strength.
 - 3. Packaging: Factory packaged for field mixing.
 - 4. Products: Chocfast by ITW Philadelphia resins, ESCOWELD or approved equal.

PART 3 - EXECUTION

3.1 PIPING SYSTEMS - COMMON REQUIREMENTS

- A. Install piping according to the following requirements and Division 23 Sections specifying piping systems.
- B. Drawing plans, schematics, and diagrams indicate general location and arrangement of piping systems. Indicated locations and arrangements were used to size pipe and calculate friction loss, expansion, pump sizing, and other design

- considerations. Install piping as indicated unless deviations to layout are approved on Coordination Drawings.
- C. Install piping in concealed locations, unless otherwise indicated and except in equipment rooms and service areas.
 - D. Install piping indicated to be exposed and piping in equipment rooms and service areas at right angles or parallel to building walls. Diagonal runs are prohibited unless specifically indicated otherwise.
 - E. Install piping above accessible ceilings to allow sufficient space for ceiling panel removal.
 - F. Install piping to permit valve servicing.
 - G. Install piping at indicated slopes.
 - H. Install piping free of sags and bends.
 - I. Install fittings for changes in direction and branch connections.
 - J. Install piping to allow application of insulation.
 - K. Select system components with pressure rating equal to or greater than system operating pressure.
 - L. Install escutcheons for penetrations of walls, ceilings, and floors according to the following:
 - 1. New Piping:
 - a. Piping with Fitting or Sleeve Protruding from Wall: One-piece, deep-pattern type.
 - b. Chrome-Plated Piping: One-piece, cast-brass type with polished chrome-plated finish.
 - c. Insulated Piping: One-piece, stamped-steel type with spring clips.
 - d. Bare Piping at Wall and Floor Penetrations in Finished Spaces: One-piece, cast-brass type with polished chrome-plated finish.
 - e. Bare Piping at Wall and Floor Penetrations in Finished Spaces: One-piece, stamped-steel type.
 - f. Bare Piping at Ceiling Penetrations in Finished Spaces: One-piece, cast-brass type with polished chrome-plated finish.
 - g. Bare Piping at Ceiling Penetrations in Finished Spaces: One-piece, stamped-steel type and set screw.
 - h. Bare Piping in Unfinished Service Spaces: One-piece, cast-brass type with polished chrome-plated finish.
 - i. Bare Piping in Unfinished Service Spaces: One-piece, stamped-steel type with spring clips.
 - j. Bare Piping in Equipment Rooms: One-piece, cast-brass type.
 - k. Bare Piping in Equipment Rooms: One-piece, stamped-steel type with spring clips.
 - l. Bare Piping at Floor Penetrations in Equipment Rooms: One-piece, floor-plate type.
 - M. Sleeves are not required for core-drilled holes except at all Penthouse and/or roof penetrations.
 - N. Permanent sleeves are not required for holes formed by removable PE sleeves except at all Penthouse and/or roof penetrations.

- O. Install sleeves for pipes passing through concrete and masonry walls and concrete floor and roof slabs.
- P. Install sleeves for pipes passing through concrete and masonry walls, gypsum-board partitions, and concrete floor and roof slabs.
 - 1. Cut sleeves to length for mounting flush with both surfaces.
 - a. Exception: Extend sleeves installed in floors of the Penthouse and/or mechanical equipment areas or other wet areas 2 inches above finished floor level. Extend cast-iron sleeve fittings below floor slab as required to secure clamping ring if ring is specified.
 - 2. Install sleeves in new walls and slabs as new walls and slabs are constructed. Air seal all penetrations at all supply and return air plenums.
 - 3. Install sleeves that are large enough to provide 1/4-inch annular clear space between sleeve and pipe or pipe insulation. Use the following sleeve materials:
 - a. Steel Pipe Sleeves: For pipes smaller than NPS 6.
 - b. Steel Sheet Sleeves: For pipes NPS 6 and larger, penetrating gypsum-board partitions 16 Gauge
 - 1) Seal space outside of sleeve fittings with grout.
 - 4. Except for underground wall penetrations, seal annular space between sleeve and pipe or pipe insulation, using joint sealants appropriate for size, depth, and location of joint. Refer to Division 07 Section "Joint Sealants" for materials and installation.
- Q. Aboveground, Exterior-Wall Pipe Penetrations: Seal penetrations using sleeves and mechanical sleeve seals. Select sleeve size to allow for 1-inch annular clear space between pipe and sleeve for installing mechanical sleeve seals.
 - 1. Install steel pipe for sleeves smaller than 6 inches in diameter.
 - 2. Install cast-iron "wall pipes" for sleeves 6 inches and larger in diameter.
 - 3. Mechanical Sleeve Seal Installation: Select type and number of sealing elements required for pipe material and size. Position pipe in center of sleeve. Assemble mechanical sleeve seals and install in annular space between pipe and sleeve. Tighten bolts against pressure plates that cause sealing elements to expand and make watertight seal.
- R. Underground, Exterior-Wall Pipe Penetrations: Install cast-iron "wall pipes" for sleeves. Seal pipe penetrations using mechanical sleeve seals. Select sleeve size to allow for 1-inch annular clear space between pipe and sleeve for installing mechanical sleeve seals.
 - 1. Mechanical Sleeve Seal Installation: Select type and number of sealing elements required for pipe material and size. Position pipe in center of sleeve. Assemble mechanical sleeve seals and install in annular space between pipe and sleeve. Tighten bolts against pressure plates that cause sealing elements to expand and make watertight seal.
- S. Fire-Barrier Penetrations: Maintain indicated fire rating of walls, partitions, ceilings, and floors at pipe penetrations. Seal pipe penetrations with firestop materials. Refer to Division 07 Section "Penetration Firestopping" for materials.
- T. Verify final equipment locations for roughing-in.
- U. Refer to equipment specifications in other Sections of these Specifications for roughing-in requirements.

3.2 PIPING JOINT CONSTRUCTION

- A. Join pipe and fittings according to the following requirements and Division 23 Sections specifying piping systems.
- B. Ream ends of pipes and tubes and remove burrs. Bevel or groove (on applicable systems) plain ends of steel pipe.
- C. Remove scale, slag, dirt, and debris from inside and outside of pipe and fittings before assembly.
- D. Soldered Joints: Apply ASTM B 813, water-flushable flux, unless otherwise indicated, to tube end. Construct joints according to ASTM B 828 or CDA's "Copper Tube Handbook," using lead-free solder alloy complying with ASTM B 32.
- E. Brazed Joints: Construct joints according to AWS's "Brazing Handbook," "Pipe and Tube" Chapter, using copper-phosphorus brazing filler metal complying with AWS A5.8.
- F. Threaded Joints: Thread pipe with tapered pipe threads according to ASME B1.20.1. Cut threads full and clean using sharp dies. Ream threaded pipe ends to remove burrs and restore full ID. Join pipe fittings and valves as follows:
 - 1. Apply appropriate tape or thread compound to external pipe threads unless dry seal threading is specified.
 - 2. Damaged Threads: Do not use pipe or pipe fittings with threads that are corroded or damaged. Do not use pipe sections that have cracked or open welds.
 - 3. Threaded fittings not allowed in glycol system.
- G. Welded Joints: Construct joints according to AWS D10.12, using qualified processes and welding operators according to Part 1 "Quality Assurance" Article.
- H. Flanged Joints: Select appropriate gasket material, size, type, and thickness for service application. Install gasket concentrically positioned. Use suitable lubricants on bolt threads.
- I. Grooved Joints: Install in accordance with the manufacturer's (Victaulic or Engineer Approved Equal) guidelines and recommendations. All grooved couplings, fittings, valves and specialties shall be supplied by a single manufacturer. Grooving tools shall be supplied by the same manufacturer as the grooved components. The gasket style and elastomeric material (grade) shall be verified as suitable for the intended service as specified. Gaskets shall be developed and supplied by the manufacturer. Grooved end shall be clean and free from indentations, projections and roll marks in the area from pipe end to groove. A Victaulic factory trained field representative shall provide on-site training to contractor's field personnel in the installation of grooved piping products. Factory trained representative shall periodically review the product installation. Contractor shall remove and replace any improperly installed products.
 - 1. Install the Victaulic AGS piping system in accordance with the latest Victaulic installation instructions. Use Victaulic grooving tools with AGS roll sets to groove the pipe. Follow Victaulic guidelines for tool selection and operation. Coupling installation shall be complete when visual metal-to-metal contact is reached. AGS products shall not be installed with standard grooved end pipe or components. Installing AGS products in combination with standard grooved end products could result in joint separation and/or leakage.
 - 2. Grooved joints not allowed on Hot Water system

3.3 PIPING CONNECTIONS

- A. Make connections according to the following, unless otherwise indicated:
 - 1. Install unions, in piping NPS 2 and smaller, adjacent to each valve and at final connection to each piece of equipment.
 - 2. Install flanges, or grooved joints, in piping NPS 2-1/2 and larger, adjacent to flanged or grooved end valves and at final connection to each piece of equipment.
 - 3. Dry Piping Systems: Install brass unions to connect piping materials of dissimilar metals.
 - 4. Wet Piping Systems: Install brass unions to connect piping materials of dissimilar metals.

3.4 DUCT SYSTEMS – COMMON REQUIREMENTS

- A. Install ductwork according to the following requirements and Division 23 Sections specifying metal ducts, casings, duct accessories and related components.
- B. Drawing plans, schematics and diagram indicate general location and arrangement of duct systems. Indicated locations and arrangements were used to size ducts and calculate friction loss, expansion, fan sizing and other design considerations. Install ductwork as indicated unless deviations to layout are approved on Coordination Drawings.
- C. Install ductwork in concealed locations, unless otherwise indicated and except in equipment rooms and service areas.
- D. Install ductwork indicated to be exposed and ductwork in equipment rooms and service areas at right angles or parallel to building walls. Diagonal runs are prohibited unless specifically indicated otherwise.
- E. Install ductwork above accessible ceilings to allow sufficient space for ceiling panel removal.
- F. Install ductwork to permit servicing of C.V. boxes, VAV boxes, dampers, actuators, filters, valves, and as required.
- G. Install with indicated horizontal and vertical offset.
- H. Install ductwork free of sags and bends.
- I. Install fittings for changes in direction and branch connections.
- J. Install ductwork to allow application of insulation.
- K. Select system components with pressure class equal to or greater than system operating pressure.

3.5 EQUIPMENT INSTALLATION - COMMON REQUIREMENTS

- A. Install equipment to allow maximum possible headroom unless specific mounting heights are not indicated.
- B. Install equipment level and plumb, parallel and perpendicular to other building systems and components in exposed interior spaces, unless otherwise indicated.
- C. Install HVAC equipment to facilitate service, maintenance, and repair or replacement of components. Connect equipment for ease of disconnecting, with

minimum interference to other installations. Extend grease fittings to accessible locations.

- D. Install equipment to allow right of way for piping installed at required slope.

3.6 PAINTING

- A. Painting of HVAC systems, equipment, and components is specified in Division 09 Sections "Interior Painting" and "Exterior Painting."
- B. Damage and Touchup: Repair marred and damaged factory-painted finishes with materials and procedures to match original factory finish.

3.7 CONCRETE BASES

- A. Concrete Bases: Anchor equipment to concrete base according to equipment manufacturer's written instructions and according to seismic codes at Project.
 1. Construct concrete bases of dimensions indicated, but not less than 4 inches larger in both directions than supported unit.
 2. Install dowel rods to connect concrete base to concrete floor. Unless otherwise indicated, install dowel rods on 18-inch centers around the full perimeter of the base.
 3. Install epoxy-coated anchor bolts for supported equipment that extend through concrete base, and anchor into structural concrete floor.
 4. Place and secure anchorage devices. Use supported equipment manufacturer's setting drawings, templates, diagrams, instructions, and directions furnished with items to be embedded.
 5. Install anchor bolts to elevations required for proper attachment to supported equipment.
 6. Install anchor bolts according to anchor-bolt manufacturer's written instructions.

3.8 ERECTION OF METAL SUPPORTS AND ANCHORAGES

- A. Refer to Division 05 Section "Metal Fabrications" for structural steel.
- B. Cut, fit, and place miscellaneous metal supports accurately in location, alignment, and elevation to support and anchor HVAC materials and equipment.
- C. Field Welding: Comply with AWS D1.1.

3.9 GROUTING

- A. Mix and install grout for HVAC equipment base bearing surfaces, pump and other equipment base plates, and anchors.
- B. Clean surfaces that will come into contact with grout.
- C. Provide forms as required for placement of grout.
- D. Avoid air entrapment during placement of grout.
- E. Place grout, completely filling equipment bases.
- F. Place grout on concrete bases and provide smooth bearing surface for equipment.
- G. Place grout around anchors.

H. Cure placed grout.

END OF SECTION

SECTION 23 05 12

BEARING PROTECTION RING FOR MOTORS

PART 1 - GENERAL

1.1 RELATED DOCUMENTS

- A. Drawings and general provisions of the Contract, including General and Supplementary Conditions and Division 01 Specification Sections, apply to this Section.
- B. Section 01 81 13 "Sustainable Design Requirements – LEED v4 for Building Design & Construction – New Construction" for sustainable design requirements and detailed sustainable design submittal requirements.
- C. Section 01 74 19 "Construction and Demolition Waste Management and Disposal" for disposal of construction, demolition and packaging waste disposal requirements.

1.2 SUMMARY

- A. Section includes general requirements for single-phase and polyphase, general-purpose, horizontal, small and medium, squirrel-cage induction motors for use on ac power systems up to 600 V.
- B. The mechanical contractor is to provide motor protection ring. The mechanical contractor to install motor protection ring. Coordinate all requirements with electrical contractor.
- C. Sustainable Building Requirements:
 - 1. The Owner requires the Contractor to implement practices and procedures to meet the project's environmental performance goals, which include achieving LEED version 4 **Certified** level Certification. Specific project goals that may impact this area of work include: use of recycled-content materials; use of locally-manufactured materials; use of low-emitting materials; construction waste recycling; and the implementation of a construction indoor air quality management plan. The Contractor shall ensure that the requirements related to these goals, as defined in the Articles below, are implemented to the fullest extent. Substitutions, or other changes to the work proposed by the Contractor or their Subcontractors, shall not be allowed if such changes compromise the aforementioned environmental goals and LEED certification.

1.3 COORDINATION

- A. Coordinate features of bearing ring with the following:
 - 1. Motor controllers
 - 2. Variable frequency motor controllers.
 - 3. Torque, speed, and horsepower requirements of the load.
 - 4. Ambient and environmental conditions of installation location.

1.4 DESCRIPTION OF BEARING PROTECTION RING

- A. VFD induced shaft voltages may also discharge through the bearing in attached equipment included gear boxes, pillow block bearings, break motor bearings, encoders, etc. Applying AEGIS SGR Bearing Protection Ring applied to the motor shaft will discharge induced electrical voltages to ground and prevent voltages from seeking a discharge path through the attached equipment.

PART 2 - PRODUCTS

2.1 GENERAL REQUIREMENTS

- A. Provide shaft grounding ring (AEGIA SGR on the AC motor to discharge shaft currents to the ground whenever variable frequency PWM drives are installed to control AC motors.
- B. Bearing ring to be circumferential conductive micro-fiber and maintenance free
- C. Provide vibration baseline readings before and after installation
- D. Installation to be preformed by factory authorized personnel only.
- E. For outdoor installations, a cover should be installed to prevent rust on the shaft. Use Ted Pella fast drying silver paint on motor shaft to help retard rust.
- F. For wash down duty application, high pressure water should not be directed onto the conductive micro fibers. Install o-ring or slinger to AEGIS SGR.
- G. For severe duty environments, install an o-ring or slinger against the AEGIS SGR to prevent ingress of excess grease or particles.
- H. Verify RPM/ surface rates with AEGIS engineering.
- I. Maximum temperature rating 300F/150C - Verify application specific temperatures with AEGIS engineering.
- J. Minimum temperature rating -40 degrees F/C - Verify application specific temperatures with AEGIS engineering.
- K. Humidity rating - 0-90% - Verify application specific acceptable humidity with AEGIS engineering
- L. Shaft preparation - Motor shaft must be clean and bear metal to ensure electrical contact of motor shaft to conductive micro fibers.
- M. Shaft - Shaft motor manufacturer standard shaft finish is suitable for AEGIS shaft grounding ring application. A nominal 130 micron finish or better.
- N. Corrosion Protection - Apply a Fast Drying Silver paint such as Ted Pella #16040-30, on shaft surface to prevent corrosion.
- O. Thread Locking Compound - Do not use Loctite or any other non-conductive material to secure the screws.
- P. Excessive Vibration - Installation bolts should be tightened and lock washers used. In some critical applications it may also be desirable to use a thread locker. In this case you must use a conductive silver epoxy such as Chemtronics Conductive Silver Epoxy CW2400.

PART 3 - EXECUTION

(Not Applicable)

END OF SECTION

This page is intentionally left blank.

SECTION 23 05 13

COMMON MOTOR REQUIREMENTS FOR HVAC EQUIPMENT

PART 1 - GENERAL

1.1 RELATED DOCUMENTS

- A. Drawings and general provisions of the Contract, including General and Supplementary Conditions and Division 01 Specification Sections, apply to this Section.
- B. Section 01 81 13 "Sustainable Design Requirements – LEED v4 for Building Design & Construction – New Construction" for sustainable design requirements and detailed sustainable design submittal requirements.
- C. Section 01 74 19 "Construction and Demolition Waste Management and Disposal" for disposal of construction, demolition and packaging waste disposal requirements.

1.2 SUMMARY

- A. Section includes general requirements for single-phase and three-phase, general-purpose, horizontal, small and medium, squirrel-cage induction motors for use on ac power systems up to 600 V and installed at equipment manufacturer's factory or shipped separately by equipment manufacturer for field installation.
- B. The mechanical contractor is to provide motor, motor controllers, fused disconnect switches and VFD's. The mechanical contractor to install motor, motor controllers, disconnect switches and VFD's. The Electrical contractor is to wire all motors, fused disconnect switches, motor controllers and VFD's. Electrical contractor to furnish and install all fuses in disconnect switches.
- C. Sustainable Building Requirements:
 - 1. The Owner requires the Contractor to implement practices and procedures to meet the project's environmental performance goals, which include achieving LEED version 4 **Certified** level Certification. Specific project goals that may impact this area of work include: use of recycled-content materials; use of locally-manufactured materials; use of low-emitting materials; construction waste recycling; and the implementation of a construction indoor air quality management plan. The Contractor shall ensure that the requirements related to these goals, as defined in the Articles below, are implemented to the fullest extent. Substitutions, or other changes to the work proposed by the Contractor or their Subcontractors, shall not be allowed if such changes compromise the aforementioned environmental goals and LEED certification.

1.3 COORDINATION

- A. Coordinate features of motors, installed units, and accessory devices to be compatible with the following:
 - 1. Motor controllers and fused disconnect switches.
 - 2. Variable frequency motor controllers.

3. Torque, speed, and horsepower requirements of the load.
4. Ratings and characteristics of supply circuit and required control sequence.
5. Ambient and environmental conditions of installation location.

PART 2 - PRODUCTS

2.1 BASE BID MANUFACTURERS

- A. Motors: Toshiba, Reliance.
- B. Motor controllers and disconnect switches:
 1. Division 260000-"Enclosed Switches and Circuit Breakers" and "Enclosed Controllers".

2.2 MOTORS

- A. Motors shall be in accordance with NEMA, IEEE, UL and ANSI C50 standards with minimum indicated horsepower and the ability to operate the drive device under all conditions without overload. Motors shall be of the same manufacturer, except those provided integrally with equipment.
- B. Motors shall be designed for continuous load to operate in ambient temperature of 104 deg F and service factor of 1.15.
- C. Efficiency of motor shall be IEEE standard 112, 1978 Test Method B. Unless noted otherwise motors shall be of premium efficiency, in order to qualify for the local utility company rebate program for New Construction, and shall meet ASHRAE 90.1-2013 as a minimum, unless the utility company rebate program for new construction is more stringent, then they shall meet the utility company requirements.
- D. Except as noted, motors below ½ hp shall be 120 volts, 60 Hertz, single phase and motors ½ hp and larger shall be 460 volts, 60 hertz, 3 phase.
- E. Except as noted, motors shall be squirrel-cage induction type, open dripproof, 1750 rpm Class B insulation. Motors mounted on equipment outdoors shall be totally enclosed fan cooled (TEFC), weatherproof, 1750 rpm, class F insulation.
- F. Motor mounted outdoor and in areas where condensation can occur shall be with electrical heaters.
- G. Provide, sealed, permanently lubricated bearings for motors.
- H. Except as noted, multispeed motors shall be variable torque type.
- I. Coordinate all motor types and sizes with motor controller types and sizes. Coordinate size and location of terminal box with electrical work. Terminal box shall be clear of ventilation openings and shall be of size to receive electrical circuit wiring.
- J. Provide foundation slide base and shaft for belt-connected motors as required for aligning pulleys.
- K. Fractional horsepower motors shall be furnished with built in overload protection, where respective controllers are without overload protection.

2.3 MOTORS WITH ADDITIONAL REQUIREMENTS

- A. Motors Used with Reduced-Voltage and Multispeed Controllers: Match wiring connection requirements for controller with required motor leads. Provide terminals in motor terminal box, suited to control method.
- B. Motors Used with Variable Frequency Controllers: Ratings, characteristics, and features coordinated with and approved by controller manufacturer.
 - 1. Windings: Copper magnet wire with moisture-resistant insulation varnish, designed and tested to resist transient spikes, high frequencies, and short time rise pulses produced by pulse-width modulated inverters.
 - 2. Energy- and Premium-Efficient Motors: Class B temperature rise; Class F insulation.
 - 3. Inverter-Duty Motors: Class F temperature rise; Class H insulation.
 - 4. Thermal Protection: Comply with NEMA MG 1 requirements for thermally protected motors.
- C. Severe-Duty Motors: Comply with IEEE 841, with 1.15 minimum service factor.

2.4 SINGLE-PHASE MOTORS

- A. Motors larger than 1/20 hp shall be electronically commutated (ECM).
- B. Bearings: Prelubricated, antifriction ball bearings or sleeve bearings suitable for radial and thrust loading.
- C. Motors 1/20 HP and Smaller: Shaded-pole type.
- D. Thermal Protection: Internal protection to automatically open power supply circuit to motor when winding temperature exceeds a safe value calibrated to temperature rating of motor insulation. Thermal-protection device shall automatically reset when motor temperature returns to normal range.

PART 3 - EXECUTION

3.1 FIELD QUALITY CONTROL

- A. Test all motors for proper operation after installation and wiring.

END OF SECTION

This page is intentionally left blank.

SECTION 23 05 14

ENCLOSED CONTROLLERS

PART 1 - GENERAL

1.1 RELATED DOCUMENTS

- A. Drawings and general provisions of the Contract, including General and Supplementary Conditions and Division 01 Specification Sections, apply to this Section.
- B. Section 01 81 13 "Sustainable Design Requirements – LEED v4 for Building Design & Construction – New Construction" for sustainable design requirements and detailed sustainable design submittal requirements.
- C. Section 01 74 19 "Construction and Demolition Waste Management and Disposal" for disposal of construction, demolition and packaging waste disposal requirements.

1.2 SUMMARY

- A. This Section includes ac, enclosed controllers rated 600 V and less, of the following types:
 - 1. Across-the-line, manual and magnetic controllers.
 - 2. Reduced-voltage controllers.
 - 3. Multispeed controllers.
 - 4. All with fused disconnect switches.
- B. Sustainable Building Requirements:
 - 1. The Owner requires the Contractor to implement practices and procedures to meet the project's environmental performance goals, which include achieving LEED version 4 **Certified** level Certification. Specific project goals that may impact this area of work include: use of recycled-content materials; use of locally-manufactured materials; use of low-emitting materials; construction waste recycling; and the implementation of a construction indoor air quality management plan. The Contractor shall ensure that the requirements related to these goals, as defined in the Articles below, are implemented to the fullest extent. Substitutions, or other changes to the work proposed by the Contractor or their Subcontractors, shall not be allowed if such changes compromise the aforementioned environmental goals and LEED certification.

1.3 WORK INCLUDED

- A. The mechanical contractor is to provide motor, motor controllers and VFD's. The mechanical contractor to install motor, motor controllers and VFD's. The Electrical contractor is to wire all motors and motor controllers.
- B. The mechanical contractor shall be responsible for coordinating all requirements of the motor and controller manufacturer.

- C. If this contractor elects to substitute or increase motor horsepower over that specified, the cost of motor, motor controllers and electrical changes shall be borne by this contractor
- D. Each motor except as noted, shall be provided with a combination fused disconnection means and across-the-line magnetic starter with push button stations mounted on cover or variable frequency drive. Coordinate requirements between trades (electrical and mechanical contractors).
- E. For automatically or remotely controlled motors, furnish hand off auto (HOA) selector switches in place of the push buttons.
- F. Provide manually operated motor starters of the proper size for all motors less than 1/2 hp which are not automatically controlled. Starters for motors 175 watts or less shall consist of a snap switch with thermal overload protection where such protection is not an integral part of the motor.
- G. Combination magnetic starters for all motors shall have thermal overload, pilot light, low voltage protection in all three phases. Include a control transformer for each magnetic starter to provide 120 volt control power with 3 sets of spare normally closed or normally open contacts
- H. Starters for motors 75 hp and above shall be solid state electronic soft start type starters.
- I. All disconnect switches shall be provided by this contractor and shall be fused suitable for the motor or equipment served.
- J. Provide enclosures for motor controllers suitable for operating environment.
- K. Where a motor control center is indicated on plans, individually mounted motor controllers shall not be utilized. Please review electrical drawings for all motor control center starters, which will be provided by others.

1.4 RELATED SECTIONS INCLUDE THE FOLLOWING:

- 1. Division 26 Section "Electrical Power Monitoring and Control" for interfacing communication and metering requirements.
- 2. Division 23 Section 230515 "Variable-Frequency Motor Controllers" for general-purpose, ac, adjustable-frequency, pulse-width-modulated controllers for use on constant torque loads in ranges up to 200 hp.
- 3. All division 230000 sections.
- 4. Division 26 Section "Enclosed Controllers".

1.5 SUBMITTALS

- A. Product Data: For each type of enclosed controller. Include dimensions and manufacturer's technical data on features, performance, electrical characteristics, ratings, and finishes.
- B. Shop Drawings: For each enclosed controller.
 - 1. Include dimensioned plans, elevations, sections, and details, including required clearances and service space around equipment. Show tabulations of installed devices, equipment features, and ratings. Include the following:
 - a. Each installed unit's type and details.
 - b. Nameplate legends.
 - c. Short-circuit current rating of integrated unit.

- d. Listed and labeled for series rating of overcurrent protective devices in combination controllers by an NRTL acceptable to authorities having jurisdiction.
 - e. Features, characteristics, ratings, and factory settings of individual overcurrent protective devices in combination controllers.
 - 2. Wiring Diagrams: Power, signal, and control wiring.
 - C. Coordination Drawings: Floor plans, drawn to scale, showing dimensioned layout, required working clearances, and required area above and around enclosed controllers where pipe and ducts are prohibited. Show enclosed controller layout and relationships between electrical components and adjacent structural and mechanical elements. Show support locations, type of support, and weight on each support. Indicate field measurements.
- 1.6 QUALITY ASSURANCE
- A. Manufacturer Qualifications: A qualified manufacturer. Maintain, within 100 miles of Project site, a service center capable of providing training, parts, and emergency maintenance and repairs.
 - B. Source Limitations: Obtain enclosed controllers of a single type through one source from a single manufacturer. Coordinate with the project electrical contractor so all equipment is compatible.
 - C. Electrical Components, Devices, and Accessories: Listed and labeled as defined in NFPA 70, Article 100, by a testing agency acceptable to authorities having jurisdiction, and marked for intended use.
 - D. Comply with NFPA 70.
- 1.7 DELIVERY, STORAGE, AND HANDLING
- A. Store enclosed controllers indoors in clean, dry space with uniform temperature to prevent condensation. Protect enclosed controllers from exposure to dirt, fumes, water, corrosive substances, and physical damage.
 - B. If stored in areas subject to weather, cover enclosed controllers to protect them from weather, dirt, dust, corrosive substances, and physical damage. Remove loose packing and flammable materials from inside controllers; install electric heating of sufficient wattage to prevent condensation.
- 1.8 PROJECT CONDITIONS
- A. Interruption of Existing Electrical Service: Do not interrupt electrical service to facilities occupied by Owner or others unless permitted under the following conditions and then only after arranging to provide temporary electrical service according to requirements indicated:
 - 1. Notify Construction Manager no fewer than two days in advance of proposed interruption of electrical service.
 - 2. Do not proceed with interruption of electrical service without Construction Manager's written permission.

1.9 COORDINATION

- A. Coordinate layout and installation of enclosed controllers with other construction including conduit, piping, equipment, and adjacent surfaces. Maintain required workspace clearances and required clearances for equipment access doors and panels.
- B. Coordinate size and location of concrete bases. Cast anchor-bolt inserts into bases. Concrete, reinforcement, and formwork requirements are specified in Division 03 Section "Cast-in-Place Concrete."
- C. Coordinate installation of roof curbs, equipment supports, and roof penetrations. These items are specified in Division 07 Section "Roof Accessories."
- D. Coordinate features of enclosed controllers and accessory devices with pilot devices and control circuits to which they connect.
- E. Coordinate features, accessories, and functions of each enclosed controller with ratings and characteristics of supply circuit, motor, required control sequence, and duty cycle of motor and load.

1.10 EXTRA MATERIALS

- A. Furnish extra materials described below that match products installed and that are packaged with protective covering for storage and identified with labels describing contents.
 - 1. Spare Fuses: Furnish one spare for every five installed, but no fewer than one set of three of each type and rating.
 - 2. Indicating Lights: Two of each type installed.

PART 2 - PRODUCTS

2.1 MANUFACTURERS

- A. Manufacturers: Subject to compliance with requirements, and compatibility with the electrical system equipment being provided, provide products by one of the following:
 - 1. ABB Power Distribution, Inc.; ABB Control, Inc. Subsidiary.
 - 2. Rockwell Automation; Allen-Bradley Co.; Industrial Control Group.

2.2 ACROSS-THE-LINE ENCLOSED CONTROLLERS

- A. Manual Controller: NEMA ICS 2, general purpose, Class A, with "quick-make, quick-break" toggle or pushbutton action, and marked to show whether unit is "OFF," "ON," or "TRIPPED."
 - 1. Overload Relay: Ambient-compensated type with inverse-time-current characteristics and NEMA ICS 2, Class 10 tripping characteristics. Relays shall have heaters and sensors in each phase, matched to nameplate, full-load current of specific motor to which they connect and shall have appropriate adjustment for duty cycle.
- B. Magnetic Controller: NEMA ICS 2, Class A, full voltage, nonreversing, across the line, unless otherwise indicated.

1. Control Circuit: 120 V; obtained from integral control power transformer of sufficient capacity to operate connected pilot, indicating and control devices, plus 100 percent spare capacity.
 2. Overload Relay: Ambient-compensated type with inverse-time-current characteristic and NEMA ICS 2, Class 10 tripping characteristic. Provide with heaters or sensors in each phase matched to nameplate full-load current of specific motor to which they connect and with appropriate adjustment for duty cycle.
 3. Adjustable Overload Relay: Dip switch selectable for motor running overload protection with NEMA ICS 2, Class 10 tripping characteristic, and selected to protect motor against voltage and current unbalance and single phasing. Provide relay with Class II ground-fault protection, with start and run delays to prevent nuisance trip on starting.
- C. Combination Magnetic Controller: Factory-assembled combination controller and fused disconnect switch.
1. Fusible Disconnecting Means: NEMA KS 1, heavy-duty, fusible switch with rejection-type fuse clips rated for fuses. Select and size fuses to provide Type 2 protection according to IEC 947-4-1, as certified by an NRTL.
 2. Nonfusible Disconnecting Means: NEMA KS 1, heavy-duty, nonfusible switch.
 3. Circuit-Breaker Disconnecting Means: NEMA AB 1, motor-circuit protector with field-adjustable, short-circuit trip coordinated with motor locked-rotor amperes.

2.3 REDUCED-VOLTAGE ENCLOSED CONTROLLERS

- A. Star-Delta Controller: NEMA ICS 2, closed transition with adjustable time delay.
- B. Part-Winding Controller: NEMA ICS 2, closed transition with separate overload relays for starting and running sequences.
- C. Autotransformer Reduced-Voltage Controller: NEMA ICS 2, closed transition.
- D. Solid-State, Reduced-Voltage Controller: NEMA ICS 2, suitable for use with NEMA MG 1, Design B, polyphase, medium induction motors.
 1. Adjustable acceleration rate control utilizing voltage or current ramp, and adjustable starting torque control with up to 500 percent current limitation for 20 seconds.
 2. Surge suppressor in solid-state power circuits providing 3-phase protection against damage from supply voltage surges 10 percent or more above nominal line voltage.
 3. LED indicators showing motor and control status, including the following conditions:
 - a. Control power available.
 - b. Controller on.
 - c. Overload trip.
 - d. Loss of phase.
 - e. Shorted silicon-controlled rectifier.
 4. Motor running contactor operating automatically when full voltage is applied to motor.

2.4 ENCLOSURES

- A. Description: Flush- or surface-mounting cabinets as indicated. NEMA 250, Type 1, unless otherwise indicated to comply with environmental conditions at installed location.
 - 1. Outdoor Locations: NEMA 250, Type 3R.
 - 2. Other Wet or Damp Indoor Locations: NEMA 250, Type 4.
 - 3. Hazardous Areas Indicated on Drawings: NEMA 250, Type 7C.

2.5 ACCESSORIES

- A. Devices shall be factory installed in controller enclosure, unless otherwise indicated.
- B. Push-Button Stations, Pilot Lights, and Selector Switches: NEMA ICS 2, heavy-duty type.
- C. Stop and Lockout Push-Button Station: Momentary-break, push-button station with a factory-applied hasp arranged so padlock can be used to lock push button in depressed position with control circuit open.
- D. Control Relays: Auxiliary and adjustable time-delay relays.
- E. Auxillary contacts (normally open/ normally closed) for Building Management System (BMS) interface and control.

2.6 FACTORY FINISHES

- A. Finish: Manufacturer's standard paint applied to factory-assembled and -tested enclosed controllers before shipping.

PART 3 - EXECUTION

3.1 EXAMINATION

- A. Examine areas and surfaces to receive enclosed controllers for compliance with requirements, installation tolerances, and other conditions affecting performance.
 - 1. Proceed with installation only after unsatisfactory conditions have been corrected.

3.2 APPLICATIONS

- A. Select features of each enclosed controller to coordinate with ratings and characteristics of supply circuit and motor; required control sequence; duty cycle of motor, controller, and load; and configuration of pilot device and control circuit affecting controller functions.
- B. Select horsepower rating of controllers to suit motor controlled.

3.3 INSTALLATION

- A. For control equipment at walls, bolt units to wall or mount on lightweight structural-steel channels bolted to wall. For controllers not at walls, provide freestanding racks complying with Division 26 Section "Hangers and Supports for Electrical Systems."

- B. Install freestanding equipment on concrete bases.
- C. Comply with mounting and anchoring requirements specified in Division 26 Section "Vibration and Seismic Controls for Electrical Systems."
- D. Enclosed Controller Fuses: Install fuses in each fusible switch. Comply with requirements in Division 26 Section "Fuses."

3.4 CONCRETE BASES

- A. Coordinate size and location of concrete bases. Verify structural requirements with structural engineer.
- B. Concrete base is specified in Division 26 Section "Hangers and Supports for Electrical Systems," and concrete materials and installation requirements are specified in Division 03.

3.5 IDENTIFICATION

- A. Identify enclosed controller, components, and control wiring according to Division 26 Section "Identification for Electrical Systems."

3.6 CONTROL WIRING INSTALLATION

- A. Install wiring between enclosed controllers according to Division 26 Section "Low-Voltage Electrical Power Conductors and Cables."
- B. Bundle, train, and support wiring in enclosures.
- C. Connect hand-off-automatic switch and other automatic-control devices where applicable.
 - 1. Connect selector switches to bypass only manual- and automatic-control devices that have no safety functions when switch is in hand position.
 - 2. Connect selector switches with enclosed controller circuit in both hand and automatic positions for safety-type control devices such as low- and high-pressure cutouts, high-temperature cutouts, and motor overload protectors.

3.7 CONNECTIONS

- A. Conduit installation requirements are specified in other Division 26 Sections. Drawings indicate general arrangement of conduit, fittings, and specialties.
- B. Ground equipment according to Division 26 Section "Grounding and Bonding for Electrical Systems."

3.8 FIELD QUALITY CONTROL

- A. Prepare for acceptance tests as follows:
 - 1. Test insulation resistance for each enclosed controller element, bus, component, connecting supply, feeder, and control circuit.
 - 2. Test continuity of each circuit.
 - 3. Perform test to demonstrate that controllers are operational and functioning in accordance with the manufacturer's recommendations and the contract documents.

3.9 ADJUSTING

- A. Set field-adjustable switches and circuit-breaker trip ranges.

END OF SECTION

This page is intentionally left blank.

This page is intentionally left blank.

SECTION 23 05 15

VARIABLE-FREQUENCY MOTOR CONTROLLERS

PART 1 - GENERAL

1.1 RELATED DOCUMENTS

- A. Drawings and general provisions of the Contract, including General and Supplementary Conditions and Division 01 Specification Sections, apply to this Section.
- B. Section 01 81 13 "Sustainable Design Requirements – LEED v4 for Building Design & Construction – New Construction" for sustainable design requirements and detailed sustainable design submittal requirements.
- C. Section 01 74 19 "Construction and Demolition Waste Management and Disposal" for disposal of construction, demolition and packaging waste disposal requirements.

1.2 SUMMARY

- A. This Section includes solid-state, PWM, VFDs for speed control of three-phase, squirrel-cage induction motors.
- B. Related Sections include the following:
 - 1. Division 26 Section "Electrical Power Monitoring and Control" for monitoring and control of motor circuits.
 - 2. Division 26 Section "Transient-Voltage Suppression for Low-Voltage Electrical Power Circuits" for low-voltage power, control, and communication surge suppressors
 - 3. All division 230000 sections.
- C. Sustainable Building Requirements:
 - 1. The Owner requires the Contractor to implement practices and procedures to meet the project's environmental performance goals, which include achieving LEED version 4 **Certified** level Certification. Specific project goals that may impact this area of work include: use of recycled-content materials; use of locally-manufactured materials; use of low-emitting materials; construction waste recycling; and the implementation of a construction indoor air quality management plan. The Contractor shall ensure that the requirements related to these goals, as defined in the Articles below, are implemented to the fullest extent. Substitutions, or other changes to the work proposed by the Contractor or their Subcontractors, shall not be allowed if such changes compromise the aforementioned environmental goals and LEED certification.

1.3 WORK INCLUDED

- 1. The mechanical contractor is to provide motor, variable frequency controllers (VFD's). The mechanical contractor to install motor, motor controllers and VFD's. The Electrical contractor is to wire all motors and VFD's
- 2. The mechanical contractor shall be responsible for coordinating all requirements of the motor and VFD manufacturer.

3. If this contractor elects to substitute or increase motor horsepower over that specified, the cost of motor, motor controllers and electrical changes shall be borne by this contractor.
4. Each motor except as noted, shall be provided with a combination fused disconnecting means and across-the-line magnetic starter with push button stations mounted on cover or variable frequency drive. Coordinate requirements between trades (electrical and mechanical contractors).
5. For automatically or remotely controlled motors, furnish hand off auto (HOA) selector switches in place of the push buttons.
6. Combination magnetic starters for all motors shall have thermal overload, pilot light, low voltage protection in all three phases. Include a control transformer for each magnetic starter to provide 120 volt control power with 3 sets of spare normally closed or normally open contacts
7. Starters for motors 75 hp and above shall be solid state electronic soft start type starters.
8. Fused disconnect switches are to be provided by the electrical contractor if not integral with equipment.
9. Provide enclosures for VFD's suitable for operating environment.

1.4 DEFINITIONS

- A. BMS: Building Management System.
- B. IGBT: Integrated gate bipolar transistor.
- C. LAN: Local area network.
- D. PID: Control action, proportional plus integral plus derivative.
- E. PWM: Pulse-width modulated.
- F. VFD: Variable frequency motor controller.
- G. VFD: Variable frequency drive same as variable frequency motor controller

1.5 SUBMITTALS

- A. Product Data: For each type of VFD. Include dimensions, mounting arrangements, location for conduit entries, shipping and operating weights, and manufacturer's technical data on features, performance, electrical ratings, characteristics, and finishes.
- B. Shop Drawings: For each VFD.
 1. Include dimensioned plans, elevations, sections, and details, including required clearances and service space around equipment. Show tabulations of installed devices, equipment features, and ratings. Include the following:
 - a. Each installed unit's type and details.
 - b. Nameplate legends.
 - c. Short-circuit current rating of integrated unit.
 - d. Listed and labeled for series rating of overcurrent protective devices in combination controllers by an NRTL acceptable to authorities having jurisdiction.
 - e. Features, characteristics, ratings, and factory settings of each motor-control center unit.
 2. Wiring Diagrams: Power, signal, and control wiring for VFDs. Provide schematic wiring diagram for each type of VFD.

- C. Coordination Drawings: Floor plans, drawn to scale, showing dimensioned layout, required working clearances, and required area above and around VFDs where pipe and ducts are prohibited. Show VFD layout and relationships between electrical components and adjacent structural and mechanical elements. Show support locations, type of support, and weight on each support. Indicate field measurements.
- D. Qualification Data: For manufacturer.
- E. Field quality-control test reports.
- F. Operation and Maintenance Data: For VFDs, all installed devices, and components to include in emergency, operation, and maintenance manuals. In addition to items specified in Division 01 Section "Operation and Maintenance Data," include the following:
 - 1. Routine maintenance requirements for VFDs and all installed components.
 - 2. Manufacturer's written instructions for testing and adjusting overcurrent protective devices.
- G. Load-Current and Overload-Relay Heater List: Compile after motors have been installed and arrange to demonstrate that selection of heaters suits actual motor nameplate full-load currents.
- H. Load-Current and List of Settings of Adjustable Overload Relays: Compile after motors have been installed and arrange to demonstrate that dip switch settings for motor running overload protection suit actual motor to be protected.
- I. Compliance to IEEE 519
 - 1. Harmonic analysis for particular jobsite including total harmonic voltage distortion and total harmonic current distortion (TDD).
 - a. The VFD manufacturer shall provide calculations, specific to this installation, showing total harmonics voltage distortion is less than 5%. Input line filters shall be sized and provided as required by the VFD manufacturer to ensure compliance with IEEE standard 519. All VFD's shall include a minimum of 5% impedance reactors, no exceptions.
 - b. No VFD shall be reviewed unless all required calculations are submitted and reviewed as part of the shop drawing submission.

1.6 QUALITY ASSURANCE

- A. Manufacturer Qualifications: A qualified manufacturer. Maintain, within 100 miles (160 km) of Project site, a service center capable of providing training, parts, and emergency maintenance and repairs.
- B. Testing Agency Qualifications: An independent agency, with the experience and capability to conduct the testing indicated, that is a member company of the InterNational Electrical Testing Association or is a nationally recognized testing laboratory (NRTL) as defined by OSHA in 29 CFR 1910.7, and that is acceptable to authorities having jurisdiction.
 - 1. Testing Agency's Field Supervisor: Person currently certified by the InterNational Electrical Testing Association or the National Institute for Certification in Engineering Technologies to supervise on-site testing specified in Part 3.
- C. Source Limitations: Obtain VFDs of a single type through one source from a single manufacturer.

- D. Electrical Components, Devices, and Accessories: Listed and labeled as defined in NFPA 70, Article 100, by a testing agency acceptable to authorities having jurisdiction, and marked for intended use.
- E. Comply with NFPA 70.
- F. All components and assembly shall be UL listed.

1.7 DELIVERY, STORAGE, AND HANDLING

- A. Deliver VFDs in shipping splits of lengths that can be moved past obstructions in delivery path as indicated.
- B. Store VFDs indoors in clean, dry space with uniform temperature to prevent condensation. Protect VFDs from exposure to dirt, fumes, water, corrosive substances, and physical damage.
- C. If stored in areas subject to weather, cover VFDs to protect them from weather, dirt, dust, corrosive substances, and physical damage. Remove loose packing and flammable materials from inside controllers; install electric heating of sufficient wattage to prevent condensation.

1.8 PROJECT CONDITIONS

- A. Environmental Limitations: Rate equipment for continuous operation, capable of driving full load without derating, under the following conditions, unless otherwise indicated:
 - 1. Ambient Temperature: 0 to 40 deg C.
 - 2. Humidity: Less than 90 percent (noncondensing).
 - 3. Altitude: Not exceeding 3300 feet (1005 m).
- B. Interruption of Existing Electrical Service: Do not interrupt electrical service to facilities occupied by Owner or others unless permitted under the following conditions and then only after arranging to provide temporary electrical service according to requirements indicated:
 - 1. Notify Construction Manager no fewer than two days in advance of proposed interruption of electrical service.
 - 2. Indicate method of providing temporary electrical service.
 - 3. Do not proceed with interruption of electrical service without Construction Manager's written permission.
- C. Product Selection for Restricted Space: Drawings indicate maximum dimensions for VFDs, including clearances between VFDs, and adjacent surfaces and other items. Comply with indicated maximum dimensions.

1.9 COORDINATION

- A. Coordinate layout and installation of VFDs with other construction including conduit, piping, equipment, and adjacent surfaces. Maintain required workspace clearances and required clearances for equipment access doors and panels.
- B. Coordinate size and location of concrete bases. Cast anchor-bolt inserts into bases. Concrete, reinforcement, and formwork requirements are specified in Division 03 Section "Cast-in-Place Concrete."

- C. Coordinate installation of roof curbs, equipment supports, and roof penetrations. These items are specified in Division 07 Section "Roof Accessories."
- D. Coordinate features of VFDs, installed units, and accessory devices with pilot devices and control circuits to which they connect.
- E. Coordinate features, accessories, and functions of each VFD and each installed unit with ratings and characteristics of supply circuit, motor, required control sequence, and duty cycle of motor and load.

1.10 EXTRA MATERIALS

- A. Furnish extra materials described below that match products installed and that are packaged with protective covering for storage and identified with labels describing contents.
 - 1. Spare Fuses: Furnish one spare for every five installed, but no fewer than one set of three of each type and rating.
 - 2. Indicating Lights: Two of each type installed.

PART 2 - PRODUCTS

2.1 MANUFACTURERS

- A. Manufacturers: Subject to compliance with requirements, provide products by one of the following:
 - 1. ABB Power Distribution, Inc.; ABB Control, Inc. Subsidiary.

2.2 VARIABLE FREQUENCY CONTROLLERS

- A. Description: NEMA ICS 2, IGBT, PWM, VFD; listed and labeled as a complete unit and arranged to provide variable speed of an NEMA MG 1, Design B, 3-phase induction motor by adjusting output voltage and frequency.
 - 1. Provide unit suitable for operation of premium-efficiency motor as defined by NEMA MG 1.
- B. Design and Rating: Match load type such as fans, blowers, and pumps; and type of connection used between motor and load such as direct or through a power-transmission connection.
- C. Output Rating: 3-phase; 6 to 60 Hz, with voltage proportional to frequency throughout voltage range .
- D. Twelve (12) Pulse Input Configuration, 25HP to 200HP
 - 1. The VFD shall be configured with a 12-pulse converter section comprised of two full wave bridge rectifiers, and an integral three-phase-shifting transformers to reduce the harmonic current distortion. The VFD, phase-shifting transformer, and bypass contactors shall be provided in one enclosure. Each 12-pulse VFD shall be furnished with a 3% line reactor and 2.5% D.C. choke to avoid line interference and act as harmonic filters
- E. Unit Operating Requirements:
 - 1. Input ac voltage tolerance of 480 0 V, plus or minus 10 percent.
 - 2. Input frequency tolerance of 60 Hz, plus or minus 6 percent.
 - 3. Minimum Efficiency: 96 percent at 60 Hz, full load.

4. Minimum Displacement Primary-Side Power Factor: 96 percent.
 5. Overload Capability: 1.1 times the base load current for 60 seconds; 1.5 times the base load current for 3 seconds.
 6. Starting Torque: 100 percent of rated torque or as indicated.
 7. Speed Regulation: Plus or minus 1 percent.
- F. Isolated control interface to allow controller to follow control signal over an 11:1 speed range.
1. Electrical Signal: 4 to 20 mA at 24 V.
- G. Internal Adjustability Capabilities:
1. Minimum Speed: 5 to 25 percent of maximum rpm.
 2. Maximum Speed: 80 to 100 percent of maximum rpm.
 3. Acceleration: 2 to a minimum of 22 seconds.
 4. Deceleration: 2 to a minimum of 22 seconds.
 5. Current Limit: 50 to a minimum of 110 percent of maximum rating.
- H. Self-Protection and Reliability Features:
1. Input transient protection by means of surge suppressors.
 2. Under- and overvoltage trips; inverter overtemperature, overload, and overcurrent trips.
 3. Motor Overload Relay: Adjustable and capable of NEMA ICS 2, Class 10 performance.
 4. Notch filter to prevent operation of the controller-motor-load combination at a natural frequency of the combination.
 5. Instantaneous line-to-line and line-to-ground overcurrent trips.
 6. Loss-of-phase protection.
 7. Reverse-phase protection.
 8. Short-circuit protection.
 9. Motor over temperature fault.
- I. Multiple-Motor Capability: Controller suitable for service to multiple motors and having a separate overload relay and protection for each controlled motor. Overload relay shall shut off controller and motors served by it when overload relay is tripped.
- J. Automatic Reset/Restart: Attempts three restarts after controller fault or on return of power after an interruption and before shutting down for manual reset or fault correction. Bidirectional autospeed search shall be capable of starting into rotating loads spinning in either direction and returning motor to set speed in proper direction, without damage to controller, motor, or load.
- K. Power-Interruption Protection: To prevent motor from re-energizing after a power interruption until motor has stopped.
- L. Torque Boost: Automatically varies starting and continuous torque to at least 1.5 times the minimum torque to ensure high-starting torque and increased torque at slow speeds.
- M. Motor Temperature Compensation at Slow Speeds: Adjustable current fall-back based on output frequency for temperature protection of self-cooled, fan-ventilated motors at slow speeds.
- N. Input Line Conditioning: Integral input 5% impedance line reactors .
- O. Status Lights: Door-mounted LED indicators shall indicate the following conditions:
1. Power on.

2. Run.
 3. Overvoltage.
 4. Line fault.
 5. Overcurrent.
 6. External fault.
- P. Panel-Mounted Operator Station: Start-stop and auto-manual selector switches with manual speed control potentiometer and elapsed time meter.
- Q. Indicating Devices: Meters or digital readout devices and selector switch, mounted flush in controller door and connected to indicate the following controller parameters:
1. Output frequency (Hz).
 2. Motor speed (rpm).
 3. Motor status (running, stop, fault).
 4. Motor current (amperes).
 5. Motor torque (percent).
 6. Fault or alarming status (code).
 7. PID feedback signal (percent).
 8. DC-link voltage (VDC).
 9. Set-point frequency (Hz).
 10. Motor output voltage (V).
- R. Control Signal Interface:
1. Electric Input Signal Interface: A minimum of 2 analog inputs (0 to 10 V or 0/4-20 mA) and 6 programmable digital inputs.
 2. Remote Signal Inputs: Capability to accept any of the following speed-setting input signals from the BMS or other control systems:
 - a. 0 to 10-V dc.
 - b. 0-20 or 4-20 mA.
 - c. Potentiometer using up/down digital inputs.
 - d. Fixed frequencies using digital inputs.
 - e. RS485.
 - f. Keypad display for local hand operation.
 3. Output Signal Interface:
 - a. A minimum of 1 analog output signal (0/4-20 mA), which can be programmed to any of the following:
 - 1) Output frequency (Hz).
 - 2) Output current (load).
 - 3) DC-link voltage (VDC).
 - 4) Motor torque (percent).
 - 5) Motor speed (rpm).
 - 6) Set-point frequency (Hz).
 4. Remote Indication Interface: A minimum of 2 dry circuit relay outputs (120-V ac, 1 A) for remote indication of the following:
 - a. Motor running.
 - b. Set-point speed reached.
 - c. Fault and warning indication (overtemperature or overcurrent).
 - d. PID high- or low-speed limits reached.
- S. Communications: Provide an RS485 interface allowing VFD to be used with an external system within a multidrop LAN configuration. Interface shall allow all parameter settings of VFD to be programmed via BMS control. Provide capability for VFD to retain these settings within the nonvolatile memory.

- T. Manual Bypass: Magnetic contactor arranged to safely transfer motor between controller output and bypass controller circuit when motor is at zero speed. Controller-off-bypass selector switch sets mode, and indicator lights give indication of mode selected. Unit shall be capable of stable operation (starting, stopping, and running), with motor completely disconnected from controller (no load)
- U. Bypass Controller: NEMA ICS 2, full-voltage, nonreversing enclosed controller with across-the-line starting capability in manual-bypass mode for motors less than 75 horsepower. Provide motor overload protection under both modes of operation with control logic that allows common start-stop capability in either mode
 - 1. Provide Solid-State, Reduced-Voltage Controller: NEMA ICS 2, suitable for use with NEMA MG 1, Design B, polyphase, medium induction motors for motors 75 horsepower and greater..
- V. Integral Disconnecting Means: NEMA AB 1, fusible disconnect switch with lockable handle rated minimum 65 K.A.I.C..
- W. Remote Indicating Circuit Terminals: Mode selection, controller status, and controller fault
- X. Provide eight adjustable set points to lock out operation at frequencies that may provide mechanical resonance.

2.3 ENCLOSURES

- A. NEMA 1 ventilated freestanding enclosure for motor horsepower listed on the design drawings. Coordinate final motor hp with fan/pump/equipment manufacturer.

2.4 ACCESSORIES

- A. Devices shall be factory installed in controller enclosure, unless otherwise indicated.
- B. Push-Button Stations, Pilot Lights, and Selector Switches: NEMA ICS 2, heavy-duty type.
- C. Stop and Lockout Push-Button Station: Momentary-break, push-button station with a factory-applied hasp arranged so padlock can be used to lock push button in depressed position with control circuit open.
- D. Control Relays: Auxiliary and adjustable time-delay relays.
- E. Standard Displays:
 - 1. Output frequency (Hz).
 - 2. Set-point frequency (Hz).
 - 3. Motor current (amperes).
 - 4. DC-link voltage (VDC).
 - 5. Motor torque (percent).
 - 6. Motor speed (rpm).
 - 7. Motor output voltage (V).
- F. Interlock terminal strip
 - 1. Provide a separate terminal strip for connection of freeze, fire, smoke and all dampers contacts and external start command. All external safety interlocks shall remain fully functional whether the system is in hand, auto, or bypass

modes. The remote start / stop contact shall operate in auto and bypass modes.

- G. Historical Logging Information and Displays:
 - 1. Real-time clock with current time and date.
 - 2. Running log of total power versus time.
 - 3. Total run time.
 - 4. Fault log, maintaining last four faults with time and date stamp for each.
- H. Line Reactors and D.C. Chokes

2.5 FACTORY FINISHES

- A. Finish: Manufacturer's standard paint applied to factory-assembled and -tested VFDs before shipping.

PART 3 - EXECUTION

3.1 EXAMINATION

- A. Examine areas, surfaces, and substrates to receive VFDs for compliance with requirements, installation tolerances, and other conditions affecting performance.
- B. Examine roughing-in for conduit systems to verify actual locations of conduit connections before VFD installation.
- C. Proceed with installation only after unsatisfactory conditions have been corrected.

3.2 APPLICATIONS

- A. Select features of each VFD to coordinate with ratings and characteristics of supply circuit and motor; required control sequence; and duty cycle of motor, controller, and load.
- B. Select horsepower rating of controllers to suit motor controlled.

3.3 INSTALLATION

- A. Anchor each VFD assembly to steel-channel sills arranged and sized according to manufacturer's written instructions. Attach by bolting. Level and grout sills flush with mounting surface.
- B. Install VFDs on concrete bases.
- C. Comply with mounting and anchoring requirements specified in Division 26 Section "Hangers and Supports for Electrical Systems."
- D. Controller Fuses: Install fuses in each fusible switch. Comply with requirements in Division 26 Section "Fuses."

3.4 CONCRETE BASES

- A. Coordinate size and location of concrete bases. Verify structural requirements with structural engineer.

- B. Concrete base is specified in Division 26 Section "Common Work Results for Electrical," and concrete materials and installation requirements are specified in Division 03.

3.5 IDENTIFICATION

- A. Identify VFDs, components, and control wiring according to Division 26 Section "Identification for Electrical Systems."
- B. Operating Instructions: Frame printed operating instructions for VFDs, including control sequences and emergency procedures. Fabricate frame of finished metal, and cover instructions with clear acrylic plastic. Mount on front of VFD units.

3.6 CONTROL WIRING INSTALLATION

- A. Install wiring between VFDs and remote devices according to Division 26 Section "Low-Voltage Electrical Power Conductors and Cables."
- B. Bundle, train, and support wiring in enclosures.
- C. Connect hand-off-automatic switch and other automatic-control devices where applicable.
 - 1. Connect selector switches to bypass only manual- and automatic-control devices that have no safety functions when switch is in hand position.
 - 2. Connect selector switches with control circuit in both hand and automatic positions for safety-type control devices such as low- and high-pressure cutouts, high-temperature cutouts, and motor overload protectors.

3.7 CONNECTIONS

- A. Conduit installation requirements are specified in other Division 26 Sections. Drawings indicate general arrangement of conduit, fittings, and specialties.
- B. Ground equipment according to Division 26 "Grounding and Bonding for Electrical Systems."

3.8 FIELD QUALITY CONTROL

- A. Prepare for acceptance tests as follows:
 - 1. Test insulation resistance for each enclosed controller element, bus, component, connecting supply, feeder, and control circuit.
 - 2. Test continuity of each circuit.
- B. Setup drive set points to lock out operation at frequencies that may provide mechanical resonance
- C. Manufacturer's Field Service: Engage a factory-authorized service representative to perform the following:
 - 1. Inspect controllers, wiring, components, connections, and equipment installation. Test and adjust controllers, components, and equipment.
 - 2. Assist in field testing of equipment including pretesting and adjusting of solid-state controllers.
 - 3. Report results in writing.
 - 4. Service station shall be located within 100 miles of job site and shall be available upon a 24-hour basis.

- D. Testing Agency: Owner will engage a qualified testing and inspecting agency to perform field tests and inspections and prepare test reports.
- E. Testing Agency: Engage a qualified testing and inspecting agency to perform the following field tests and inspections and prepare test reports:
- F. Perform the following field tests and inspections and prepare test reports:
 - 1. Perform each electrical test and visual and mechanical inspection, except optional tests, stated in NETA ATS. Certify compliance with test parameters.
 - 2. Correct malfunctioning units on-site, where possible, and retest to demonstrate compliance; otherwise, replace with new units and retest

3.9 ADJUSTING

- A. Set field-adjustable switches and circuit-breaker trip ranges.

3.10 DEMONSTRATION

- A. Engage a factory-authorized service representative to train Owner's maintenance personnel to adjust, operate, and maintain variable frequency controllers. Refer to Division 01 Section "Demonstration and Training."

END OF SECTION

This page is intentionally left blank.

SECTION 23 05 16

EXPANSION FITTINGS AND LOOPS FOR HVAC PIPING

PART 1 - GENERAL

1.1 RELATED DOCUMENTS

- A. Drawings and general provisions of the Contract, including General and Supplementary Conditions and Division 01 Specification Sections, apply to this Section.
- B. Section 01 81 13 "Sustainable Design Requirements – LEED v4 for Building Design & Construction – New Construction" for sustainable design requirements and detailed sustainable design submittal requirements.
- C. Section 01 74 19 "Construction and Demolition Waste Management and Disposal" for disposal of construction, demolition and packaging waste disposal requirements

1.2 SUMMARY

- A. Section Includes:
 - 1. Metal-bellows expansion joints.
 - 2. Expansion compensators.
 - 3. Flexible-hose expansion joints.
 - 4. Packed slip expansion joints.
 - 5. Flexible ball joints.
 - 6. Pipe bends and loops.
 - 7. Alignment guides and anchors.
- B. Sustainable Building Requirements:
 - 1. The Owner requires the Contractor to implement practices and procedures to meet the project's environmental performance goals, which include achieving LEED version 4 **Certified** level Certification. Specific project goals that may impact this area of work include: use of recycled-content materials; use of locally-manufactured materials; use of low-emitting materials; construction waste recycling; and the implementation of a construction indoor air quality management plan. The Contractor shall ensure that the requirements related to these goals, as defined in the Articles below, are implemented to the fullest extent. Substitutions, or other changes to the work proposed by the Contractor or their Subcontractors, shall not be allowed if such changes compromise the aforementioned environmental goals and LEED certification.

1.3 DEFINITIONS

- A. BR: Butyl rubber.
- B. Buna-N: Nitrile rubber.
- C. CR: Chlorosulfonated polyethylene synthetic rubber.
- D. CSM: Chlorosulfonyl-polyethylene rubber.

- E. EPDM: Ethylene-propylene-diene terpolymer rubber.
- F. NR: Natural rubber.
- G. PTFE: Polytetrafluoroethylene plastic.

1.4 PERFORMANCE REQUIREMENTS

- A. Compatibility: Products shall be suitable for piping system fluids, materials, working pressures, and temperatures.
- B. Capability: Products shall absorb 200 percent of maximum axial movement between anchors.

1.5 SUBMITTALS

- A. Product Data: For each type of product indicated.
- B. Delegated-Design Submittal: For each anchor and alignment guide indicated to comply with performance requirements and design criteria, including analysis data signed and sealed by the qualified professional engineer responsible for their preparation.
 - 1. Design Calculations: Calculate requirements for thermal expansion of piping systems and for selecting and designing expansion joints, loops, and bends.
 - 2. Anchor Details: Detail fabrication of each anchor indicated. Show dimensions and methods of assembly and attachment to building structure.
 - 3. Alignment Guide Details: Detail field assembly and attachment to building structure.
 - 4. Schedule: Indicate type, manufacturer's number, size, material, pressure rating, end connections, and location for each expansion joint
 - 5. Coordination:
 - a. Coordinate the location of all anchors, guides and expansion devices with the structural engineer.
 - b. Submit details for attachment to the building structure to the structural engineer including all loads and supplemental steel.
 - c. Coordinate the location of items in this section with access requirements for equipment, valves, dampers, as required for work in other sections, and as indicated on the drawings.
- C. Welding certificates.
- D. Product Certificates: For each type of pipe expansion joint, signed by product manufacturer.
- E. Maintenance Data: For pipe expansion joints to include in maintenance manuals.
- F. Grooved joint couplings and fittings shall be shown on drawings and product submittals, and be specifically identified with the applicable Victaulic style or series number.

1.6 QUALITY ASSURANCE

- A. Welding Qualifications: Qualify procedures and personnel according to the following:
 - 1. Steel Shapes and Plates: AWS D1.1, "Structural Welding Code - Steel."
 - 2. Welding to Piping: ASME Boiler and Pressure Vessel Code: Section IX.

- B. Engineering Responsibility: Design and preparation of Shop Drawings and calculations for expansion fittings and loops by a qualified professional engineer
 - 1. Professional Engineer Qualifications: A professional engineer who is legally qualified to practice in jurisdiction where Project is located and who is experienced in providing engineering services of the kind indicated. Engineering services are defined as those performed for installations of expansion fittings and loops that are similar to those indicated for this Project in material, design, and extent.
- C. To assure uniformity and compatibility of piping components in grooved piping systems, all grooved products utilized shall be supplied by a single manufacturer. Grooving tools shall be supplied by the same manufacturer as the grooved components.

PART 2 - PRODUCTS

2.1 EXPANSION JOINTS

- A. Metal-Bellows Expansion Joints: ASTM F 1120, circular-corrugated-bellows type with external tie rods.
 - 1. Manufacturers: Subject to compliance with requirements, provide products by one of the following:
 - a. Adscos Manufacturing, LLC.
 - b. Badger Industries.
 - c. Hyspan Precision Products, Inc.
 - d. Metraflex, Inc.
 - 2. Metal-Bellows Expansion Joints for Copper Piping: Single- or multiple-ply phosphor-bronze bellows, copper pipe end connections, and brass shrouds.
 - 3. Metal-Bellows Expansion Joints for Stainless-Steel Waterway: Single-ply stainless-steel bellows, stainless-steel-pipe end connections, and steel shroud.
 - 4. Metal-Bellows Expansion Joints for Steel Piping: Single- or multiple-ply stainless-steel bellows, steel pipe end connections, and carbon-steel shroud.
 - 5. Minimum Pressure Rating: 150 psig unless otherwise indicated.
 - 6. Configuration: Single- or double bellows type with base, unless otherwise indicated.
 - 7. End Connections: Flanged welded or Brazed.
- B. Expansion Compensators: Double-ply corrugated steel, stainless-steel, or copper-alloy bellows in a housing with internal guides, antitorque device, and removable end clip for positioning.
 - 1. Manufacturers: Subject to compliance with requirements, provide products by one of the following:
 - a. Adscos Manufacturing, LLC.
 - b. Hyspan Precision Products, Inc.
 - c. Metraflex, Inc.
 - 2. Minimum Pressure Rating: 150 psig unless otherwise indicated.
 - 3. Configuration for Copper Piping: Two-ply phosphor-bronze or stainless-steel bellows and bronze or stainless-steel shroud.
 - 4. Configuration for Steel Piping: Two-ply stainless-steel bellows and carbon-steel shroud.

5. End Connections for Copper Tubing NPS 2 and Smaller: Solder joint or threaded.
 6. End Connections for Copper Tubing NPS 2-1/2 to NPS 4: Solder joint .
 7. End Connections for Steel Pipe NPS 2 and Smaller: Threaded.
 8. End Connections for Steel Pipe NPS 2-1/2 to NPS 4: Flanged, threaded or Welded.
- C. Flexible-Hose Expansion Joints: Manufactured assembly with two flexible-metal-hose legs joined by long-radius, 180-degree return bend or center section of flexible hose; with inlet and outlet elbow fittings, corrugated-metal inner hoses, and braided outer sheaths.
1. Manufacturers: Subject to compliance with requirements, provide products by one of the following:
 - a. Flexicraft Industries.
 - b. Metraflex, Inc.
 2. Flexible-Hose Expansion Joints for Copper Piping: Copper-alloy fittings with solder- joint end connections.
 - a. NPS 2 and Smaller: Bronze hoses and single-braid bronze sheaths with 450 psig at 70 deg F and 340 psig at 450 deg F ratings.
 - b. NPS 2-1/2 to NPS 4: Stainless-steel hoses and single-braid, stainless-steel sheaths with 300 psig at 70 deg F and 225 psig at 450 deg F ratings.
 3. Flexible-Hose Expansion Joints for Copper Piping: Copper-alloy fittings with solder- joint end connections.
 - a. NPS 2 and Smaller: Bronze hoses and double-braid bronze sheaths with 700 psig at 70 deg F and 500 psig at 450 deg F ratings.
 - b. NPS 2-1/2 to NPS 4: Stainless-steel hoses and double-braid, stainless-steel sheaths with 420 psig at 70 deg F and 315 psig at 450 deg F ratings.
 4. Flexible-Hose Expansion Joints for Steel Piping: Carbon-steel fittings with threaded end connections for NPS 2 and smaller and flanged or weld end connections for NPS 2-1/2 and larger.
 - a. NPS 2 and Smaller: Stainless-steel hoses and single-braid, stainless-steel sheaths with 450 psig at 70 deg F and 325 psig at 600 deg F ratings.
 - b. NPS 2-1/2 to NPS 6: Stainless-steel hoses and single-braid, stainless-steel sheaths with 200 psig at 70 deg F and 145 psig at 600 deg F ratings.
 - c. NPS 8 to NPS 12: Stainless-steel hoses and single-braid, stainless-steel sheaths with 125 psig at 70 deg F and 90 psig at 600 deg F ratings.
 5. Flexible-Hose Expansion Joints for Steel Piping: Carbon-steel fittings with threaded end connections for NPS 2 and smaller and flanged or weld end connections for NPS 2-1/2 and larger.
 - a. NPS 2 and Smaller: Stainless-steel hoses and double-braid, stainless-steel sheaths with 700 psig at 70 deg F and 515 psig at 600 deg F ratings.
 - b. NPS 2-1/2 to NPS : Stainless-steel hoses and double-braid, stainless-steel sheaths with 275 psig at 70 deg F and 200 psig at 600 deg F ratings.
 - c. NPS 8 and Larger: Stainless-steel hoses and double-braid, stainless-steel sheaths with 165 psig at 70 deg F and 120 psig at 600 deg F ratings.

- D. Packed Slip Expansion Joints: ASTM F 1007, carbon-steel, packing type designed for repacking under pressure and pressure rated for 250 psig at 400 deg F minimum. Include asbestos-free PTFE packing, compound limit stops, and drip connection if used for steam piping.
1. Manufacturers: Subject to compliance with requirements, provide products by one of the following:
 - a. Adsko Manufacturing, LLC. Type RJ
 - b. Advanced Thermal Systems, Inc. Thermal Pak-Type TP2
 - c. Hyspan Precision Products, Inc.
 2. Configuration: Single- and double joint class with base, unless otherwise indicated.
 3. End Connections: Flanged or weld ends to match piping system.
- E. Packed type: Provide single or double slip, with anchor base except as noted. Provide internal and external guides integral with stuffing box; wrought steel with chromium plating applied directly to polished steel surface. Provide butt weld ends, except as noted.
1. Provide limit stops, capable of holding against full internal thrust.
 2. Packing: Provide self-lubricating asbestos-free polytetrafluoroethylene or asbestos-free reinforced teflon type, which can be injected under full line pressure, contained by minimum of 3 teflon non-asbestos rings at each side.
 3. Provide joints body of weldable quality carbon steel, ASTM 53 grade B seamless pipe with drip connection if used for steam service.
 4. Slip requirements: Provide ASTM A 53 grade B seamless pipe up to and including 12 inch: Schedule 80 and 16 inch through 24 inch: Schedule 60.
 - a. Provide wall thickness after machining not reduced more than 1/8 inch.
 - b. Provide double layer of chrome plating with minimum thickness 0.001 inch each after buffing. First layer: crack-free hard chrome; second layer: standard hard chrome.
 5. Provide welded steel packing cylinder with internal acme thread and male threaded plunger with cylinder welded directly to stuffing box. Minimum number of packing cylinders as follows:

<u>Expansion Joint Size</u>	<u>Number of Packing Cylinders</u>
1-1/2 inch thru 4 inch	1
5 inch and 6 inch	3
8 inch and 10 inch	4
12 inch and 14 inch	5
16 inch and 18 inch	6
20 inch and 24 inch	8

6. Pressure ratings:
 - a. All piping: 150 lb.
 7. Provide all welding in accordance with Section IX of ASME Boiler and Pressure Vessel Code.
- F. Flexible Ball Joints: Carbon-steel assembly with asbestos-free composition packing, designed for 360-degree rotation and angular deflection, and 250 psig at 400 deg F minimum pressure rating; complying with ASME Boiler and Pressure Vessel Code: Section II, "Materials," and with ASME B31.9, "Building Services Piping," for materials and design of pressure-containing parts and bolting.
1. Angular Deflection for NPS 6 and Smaller: 30-degree minimum.
 2. Angular Deflection for NPS 8 and Larger: 15-degree minimum.

3. End Connections for NPS 2 and Smaller: Threaded.
 4. End Connections for NPS 2-1/2 and Larger: Flanged.
 5. Manufacturers: Subject to compliance with requirements, provide products by one of the following:
 - a. Advanced Thermal Systems, Inc.
 - b. Hyspan Precision Products, Inc.
- G. Grooved End Expansion Joints for Steel Piping: Use in water piping systems 2-1/2" and larger that are installed within enclosures where a pipe bend or loop cannot be applied. Grooved joints not to be used on hot water systems.
1. Manufacturers: Subject to compliance with requirements provide products by one of the following:
 - a. Victaulic Company
 2. 2" Through 6": Packless, gasketed, slip-type expansion joint with grooved end telescoping body for installation with Victaulic Style 07 rigid couplings. Provides axial end movement to 3", designed for water services up to 230°F and working pressure to 350 psi. Victaulic Style 150 Mover®.
 3. 2" Through 24": Combination of short nipples and Victaulic Style 75 or 77 flexible couplings joined in tandem for increased expansion. Joint movement and expansion capabilities dependent on number of couplings/nipples used in the joint. Pressure rating dependent on size and style of flexible couplings used. Victaulic Style 155.

2.2 ALIGNMENT GUIDES

- A. Description: Steel, factory fabricated, with bolted two-section outer cylinder and base for alignment of piping and two-section guiding spider for bolting to pipe.
1. Manufacturers: Subject to compliance with requirements, provide products by one of the following:
 - a. Adesco Manufacturing, LLC.
 - b. Advanced Thermal Systems, Inc.
 - c. B-Line systems, Inc.
 - d. Grinnell Corp.

2.3 MATERIALS FOR ANCHORS

- A. Steel Shapes and Plates: ASTM A 36/A 36M.
- B. Bolts and Nuts: ASME B18.10 or ASTM A 183, steel, hex head.
- C. Washers: ASTM F 844, steel, plain, flat washers.
- D. Mechanical Fasteners: Insert-wedge-type stud with expansion plug anchor for use in hardened portland cement concrete, and tension and shear capacities appropriate for application.
1. Stud: Threaded, zinc-coated carbon steel.
 2. Expansion Plug: Zinc-coated steel.
 3. Washer and Nut: Zinc-coated steel.
- E. Chemical Fasteners: Insert-type-stud bonding system anchor for use with hardened portland cement concrete, and tension and shear capacities appropriate for application.
1. Bonding Material: ASTM C 881, Type IV, Grade 3, 2-component epoxy resin suitable for surface temperature of hardened concrete where fastener is to be installed.

2. Stud: ASTM A 307, zinc-coated carbon steel with continuous thread on stud, unless otherwise indicated.
 3. Washer and Nut: Zinc-coated steel.
- F. Concrete: Portland cement mix, 3000 psi minimum. Comply with requirements in Division 03 Section "Cast-in-Place Concrete" for formwork, reinforcement, and concrete.
- G. Grout: ASTM C 1107, factory-mixed and -packaged, dry, hydraulic-cement, nonshrink, nonmetallic grout; suitable for interior and exterior applications.
1. Properties: Nonstaining, noncorrosive, and nongaseous.
 2. Design Mix: 5000-psi, 28-day compressive strength.

PART 3 - EXECUTION

3.1 EXPANSION-JOINT INSTALLATION

- A. Install manufactured, nonmetallic expansion joints according to FSA's "Technical Handbook: Non-Metallic Expansion Joints and Flexible Pipe Connectors."
- B. Install expansion joints of sizes matching size of piping in which they are installed.
- C. Install alignment guides to allow expansion and to avoid end-loading and torsional stress.
- D. Grooved joint piping systems shall be installed in accordance with the manufacturer's guidelines and recommendations. All grooved couplings, fittings, valves and specialties shall be supplied by a single manufacturer. Grooving tools shall be supplied by the same manufacturer as the grooved components. The gasket style and elastomeric material (grade) shall be verified as suitable for the intended service as specified. Gaskets shall be developed and supplied by the manufacturer. Grooved end shall be clean and free from indentations, projections and roll marks in the area from pipe end to groove. A factory trained field representative shall provide on-site training to contractor's field personnel in the installation of grooved piping products. Factory trained representative shall periodically review the product installation. Contractor shall remove and replace any improperly installed products.

3.2 PIPE BEND AND LOOP INSTALLATION

- A. Install pipe bends and loops cold-sprung in tension or compression as required to partly absorb tension or compression produced during anticipated change in temperature.
- B. Expansion: Install piping to permit free expansion and contraction without damaging piping or construction.
 1. Provide offsets, expansion loops, anchors, guides and supports to permit expansion, with stress limits of ASME Code for Pressure Piping for temperature range of 40 deg F to minimum of 20 deg F above maximum system temperature.
- C. Attach pipe bends and loops to anchors.
 1. Steel Anchors: Attach by welding. Comply with ASME B31.9 and ASME Boiler and Pressure Vessel Code: Section IX, "Welding and Brazing Qualifications."

2. Concrete Anchors: Attach by fasteners. Follow fastener manufacturer's written instructions.

3.3 SWING CONNECTIONS

- A. Connect risers and branch connections to mains with at least five pipe fittings, including tee in main.
- B. Connect risers and branch connections to terminal units with at least four pipe fittings, including tee in riser.
- C. Connect mains and branch connections to terminal units with at least four pipe fittings, including tee in main.

3.4 ALIGNMENT-GUIDE INSTALLATION

- A. Install guides on piping adjoining pipe expansion fittings and loops.
- B. Attach guides to pipe and secure to building structure.

3.5 ANCHOR INSTALLATION

- A. Install anchors at locations to prevent stresses from exceeding those permitted by ASME B31.9 and to prevent transfer of loading and stresses to connected equipment.
- B. Fabricate and install steel anchors by welding steel shapes, plates, and bars to piping and to structure. Comply with ASME B31.9 and AWS D1.1.
- C. Construct concrete anchors of poured-in-place concrete of dimensions indicated and include embedded fasteners.
- D. Install pipe anchors according to expansion-joint manufacturer's written instructions if expansion joints or compensators are indicated.
- E. Use grout to form flat bearing surfaces for expansion fittings, guides, and anchors installed on or in concrete.

3.6 PAINTING

- A. Touching Up: Clean field welds and abraded areas of shop paint. Paint exposed areas immediately after erecting hangers and supports. Use same materials as used for shop painting. Comply with SSPC-PA 1 requirements for touching up field-painted surfaces.
 1. Apply paint by brush or spray to provide a minimum dry film thickness of 2.0 mils.
- B. Galvanized Surfaces: Clean welds, bolted connections, and abraded areas and apply galvanizing-repair paint to comply with ASTM A 780.

END OF SECTION

SECTION 23 05 19

METERS AND GAGES FOR HVAC PIPING

PART 1 - GENERAL

1.1 RELATED DOCUMENTS

- A. Drawings and general provisions of the Contract, including General and Supplementary Conditions and Division 01 Specification Sections, apply to this Section.
- B. Section 01 81 13 "Sustainable Design Requirements – LEED v4 for Building Design & Construction – New Construction" for sustainable design requirements and detailed sustainable design submittal requirements.
- C. Section 01 74 19 "Construction and Demolition Waste Management and Disposal" for disposal of construction, demolition and packaging waste disposal requirements.

1.2 SUMMARY

- A. Section Includes:
 - 1. Thermometers.
 - 2. Thermometer wells.
 - 3. Gages.
 - 4. Test plugs.
 - 5. Thermal Energy Meters
- B. This Contractor shall provide all devices, piping, valving, relays, end switches, control components, power wiring, control wiring and interlock wiring as required to accomplish the sequence of operations for the specified meters and instrumentation and thereby provide a fully operational system
- C. Sustainable Building Requirements:
 - 1. The Owner requires the Contractor to implement practices and procedures to meet the project's environmental performance goals, which include achieving LEED version 4 **Certified** level Certification. Specific project goals that may impact this area of work include: use of recycled-content materials; use of locally-manufactured materials; use of low-emitting materials; construction waste recycling; and the implementation of a construction indoor air quality management plan. The Contractor shall ensure that the requirements related to these goals, as defined in the Articles below, are implemented to the fullest extent. Substitutions, or other changes to the work proposed by the Contractor or their Subcontractors, shall not be allowed if such changes compromise the aforementioned environmental goals and LEED certification.

1.3 DEFINITIONS

- A. CR: Chlorosulfonated polyethylene synthetic rubber.
- B. EPDM: Ethylene-propylene-diene terpolymer rubber.

1.4 SUBMITTALS

- A. Product Data: For each type of product indicated; include performance curves.
- B. Shop Drawings: Schedule for thermometers, gages and flowmeters indicating manufacturer's number, scale range, and location for each.
- C. Product Certificates: For each type of thermometer, gage and flowmeter, signed by product manufacturer.
- D. Operation and Maintenance Data: For flowmeters to include in emergency, operation, and maintenance manuals.

1.5 QUALITY ASSURANCE

- A. Product options: Drawings indicate size, profiles and connections for instrumentation and are based on the specific types and models indicated.
- B. Electrical components, devices and accessories: Listed and labeled as defined in NFPA 70, Article 100, by a testing agency acceptable to authorities having jurisdiction.
- C. Standards: If any item in this specification as furnished by the contractor is manufactured in a location which does not certify ASME/ANSI standards, the contractor is to pay the owner for all expenses incurred by the owner for an outside testing company to confirm such compliances.
- D. Pressure and temperature rating:
 - 1. Each meter and gauge shall be rated and suitable for the piping system that it is being installed in.
 - 2. Refer to applicable piping section for service temperature and pressure rating of systems that meters and gauges are to be installed in.
 - 3. Minimum upstream and downstream straight pipe diameters for meters shall be provided as per manufacturer's published recommendations.

1.6 COORDINATION

- A. Coordinate the location and installation of all items furnished under this specification with and including but not limited to the following:
 - 1. Equipment installation details.
 - 2. Purchased equipment.
 - 3. Piping shop drawings.
 - 4. Field conditions.

PART 2 - PRODUCTS

2.1 METAL-CASE, LIQUID-IN-GLASS THERMOMETERS

- A. Manufacturers: Subject to compliance with requirements, provide products by one of the following:
 - 1. Terrice, H. O. Co.
 - 2. Weiss Instruments, Inc.
 - 3. Weksler Instruments Operating Unit; Dresser Industries; Instrument Div.
 - 4. Miljoco Corporation

- B. Case: Die-cast aluminum 9 inches long.
- C. Tube: Red or blue reading, organic-liquid filled, with magnifying lens, silicone shock mounted.
- D. Tube Background: Satin-faced, nonreflective aluminum with permanently etched scale markings.
- E. Window: Plastic.
- F. Connector: Adjustable type, 180 degrees in vertical plane.
- G. Stem: Copper-plated steel, aluminum, or brass for thermowell installation and of length to suit installation.
- H. Accuracy: Plus or minus 1 percent of range or plus or minus 1 scale division to maximum of 1.5 percent of range.

2.2 DIRECT-MOUNTING, VAPOR-ACTUATED DIAL THERMOMETERS

- A. Manufacturers: Subject to compliance with requirements, provide products by one of the following:
 - 1. Ashcroft Commercial Instrument Operations; Dresser Industries; Instrument Div.
 - 2. KOBOLD Instruments, Inc.
 - 3. Trerice, H. O. Co.
 - 4. Weiss Instruments, Inc.
 - 5. Weksler Instruments Operating Unit; Dresser Industries; Instrument Div
 - 6. Miljoco Corporation
- B. Case: Dry type, stainless steel , 4-1/2-inch diameter.
- C. Element: Bourdon tube or other type of pressure element.
- D. Movement: Mechanical, connecting element and pointer.
- E. Dial: Satin-faced, nonreflective aluminum with permanently etched scale markings.
- F. Pointer: Red metal.
- G. Window: Plastic.
- H. Ring: Stainless steel .
- I. Connector: Adjustable type, 180 degrees in vertical plane, 360 degrees in horizontal plane, with locking device.
- J. Thermal System: Liquid- filled bulb in copper-plated steel, aluminum, or brass stem for thermowell installation and of length to suit installation.
- K. Accuracy: Plus or minus 1 percent of range or plus or minus 1 scale division to maximum of 1.5 percent of range.

2.3 REMOTE-MOUNTING, VAPOR-ACTUATED DIAL THERMOMETERS

- A. Manufacturers: Subject to compliance with requirements, provide products by one of the following:
 - 1. AMETEK, Inc.; U.S. Gauge Div.
 - 2. Ashcroft Commercial Instrument Operations; Dresser Industries; Instrument Div.

3. Miljoco Corp.
 4. Trerice, H. O. Co.
 5. Weiss Instruments, Inc.
 6. Weksler Instruments Operating Unit; Dresser Industries; Instrument Div.
- B. Case: Dry type, stainless steel, 4-1/2-inch diameter with holes for panel mounting.
- C. Element: Bourdon tube or other type of pressure element.
- D. Movement: Mechanical, connecting element and pointer.
- E. Dial: Satin-faced, nonreflective aluminum with permanently etched scale markings.
- F. Pointer: Red metal.
- G. Window: Plastic.
- H. Ring: Stainless steel.
- I. Connector: Back union type.
- J. Thermal System: Liquid-filled bulb in copper-plated steel, aluminum, or brass stem for thermowell installation and of length to suit installation.
- K. Accuracy: Plus or minus 1 percent of range or plus or minus 1 scale division to maximum of 1.5 percent of range.

2.4 BIMETALLIC-ACTUATED DIAL THERMOMETERS

- A. Manufacturers: Subject to compliance with requirements, provide products by one of the following:
1. Ashcroft Commercial Instrument Operations; Dresser Industries; Instrument Div.
 2. Miljoco Corp.
 3. Trerice, H. O. Co.
 4. Weiss Instruments, Inc.
 5. Weksler Instruments Operating Unit; Dresser Industries; Instrument Div.
 6. WIKA Instrument Corporation.
- B. Description: Direct-mounting, bimetallic-actuated dial thermometers complying with ASME B40.3.
- C. Case: Liquid-filled type, stainless steel with 5-inch (127-mm) diameter.
- D. Element: Bimetal coil.
- E. Dial: Satin-faced, nonreflective aluminum with permanently etched scale markings.
- F. Pointer: Red metal.
- G. Window: Plastic.
- H. Ring: Stainless steel.
- I. Connector: Adjustable angle type.
- J. Stem: Metal, for thermowell installation and of length to suit installation.
- K. Accuracy: Plus or minus 1 percent of range or plus or minus 1 scale division to maximum of 1.5 percent of range.

2.5 THERMOWELLS

- A. Manufacturers: Subject to compliance with requirements, provide products by one of the following:
 - 1. Miljoco Corp.
 - 2. Terice, H. O. Co.
 - 3. Weiss Instruments, Inc.
 - 4. Weksler Instruments Operating Unit; Dresser Industries; Instrument Div.
 - 5. WIKA Instrument Corporation.
- B. Manufacturers: Same as manufacturer of thermometer being used.
- C. Description: Pressure-tight, socket-type metal fitting made for insertion into piping and of type, diameter, and length required to hold thermometer.

2.6 PRESSURE GAGES

- A. Manufacturers: Subject to compliance with requirements, provide products by one of the following:
 - 1. Miljoco Corp.
 - 2. Terice, H. O. Co.
 - 3. Weiss Instruments, Inc.
 - 4. Weksler Instruments Operating Unit; Dresser Industries; Instrument Div.
- B. Dry type for steam only, liquid-filled case type for all other services.
- C. Direct-Mounting, Dial-Type Pressure Gages: Indicating-dial type complying with ASME B40.100.
 - 1. Case: Liquid-filled type, cast aluminum , 4-1/2-inch diameter.
 - 2. Pressure-Element Assembly: Bourdon tube, unless otherwise indicated.
 - 3. Pressure Connection: Brass, NPS 1/4, bottom-outlet type unless back-outlet type is indicated.
 - 4. Movement: Mechanical, with link to pressure element and connection to pointer.
 - 5. Dial: Satin-faced, nonreflective aluminum with permanently etched scale markings.
 - 6. Pointer: Red metal.
 - 7. Window: Plastic.
 - 8. Ring: Aluminum .
 - 9. Accuracy: Grade A, plus or minus 1 percent of middle half scale.
 - 10. Vacuum-Pressure Range: 30-in. Hg of vacuum to 15 psig of pressure.
 - 11. Range for Fluids under Pressure: Two times operating pressure.
- D. Remote-Mounting, Dial-Type Pressure Gages: ASME B40.100, indicating-dial type.
 - 1. Case: Dry type, cast aluminum, 4-1/2-inch diameter with holes for panel mounting.
 - 2. Pressure-Element Assembly: Bourdon tube, unless otherwise indicated.
 - 3. Pressure Connection: Brass, NPS 1/4, bottom-outlet type unless back-outlet type is indicated.
 - 4. Movement: Mechanical, with link to pressure element and connection to pointer.
 - 5. Dial: Satin-faced, nonreflective aluminum with permanently etched scale markings.
 - 6. Pointer: Red metal.
 - 7. Window: Plastic.

8. Ring: Aluminum.
 9. Accuracy: Grade A, plus or minus 1 percent of middle half scale.
 10. Vacuum-Pressure Range: 30-in. Hg of vacuum to 15 psig of pressure.
 11. Range for Fluids under Pressure: Two times operating pressure.
- E. Provide single gauge for pump installations mounted to a 4-port trumpet valve
- F. Pressure-Gage Fittings:
1. Valves: NPS 1/4 brass or stainless-steel needle type.
 2. Syphons: NPS 1/4 coil of brass tubing with threaded ends.
 3. Snubbers: ASME B40.5, NPS 1/4 brass bushing with corrosion-resistant, porous-metal disc of material suitable for system fluid and working pressure.

2.7 TEST PLUGS

- A. Manufacturers: Subject to compliance with requirements, provide products by one of the following:
1. Trecice, H. O. Co.
 2. Watts Industries, Inc.; Water Products Div.
- B. Description: Corrosion-resistant brass or stainless-steel body with core inserts and gasketed and threaded cap, with extended stem for units to be installed in insulated piping.
- C. Minimum Pressure and Temperature Rating: 500 psig at 200 deg F.
- D. Core Inserts: One or two self-sealing rubber valves.
1. Insert material for air, water, oil, or gas service at 20 to 200 deg F shall be CR.
 2. Insert material for air or water service at minus 30 to plus 275 deg F shall be EPDM.
- E. Test Kit: Furnish one test kit containing one pressure gage and adaptor, two thermometer(s), and carrying case. Pressure gage, adapter probes, and thermometer sensing elements shall be of diameter to fit test plugs and of length to project into piping.
1. Pressure Gage: Small bourdon-tube insertion type with 2- to 3-inch-diameter dial and probe. Dial range shall be 0 to 200 psig.
 2. Low-Range Thermometer: Small bimetallic insertion type with 1- to 2-inch-diameter dial and tapered-end sensing element. Dial ranges shall be 25 to 125 deg F.
 3. High-Range Thermometer: Small bimetallic insertion type with 1- to 2-inch-diameter dial and tapered-end sensing element. Dial ranges shall be 0 to 220 deg F.
 4. Carrying case shall have formed instrument padding.

2.8 INSERTION-TURBINE, THERMAL-ENERGY METER SYSTEMS

- A. Manufacturers: Subject to compliance with requirements, provide products by one of the following:
1. Data Industrial Corp.
 2. ONICON Incorporated.
- B. Description: Flow sensor, strainer, two temperature sensors, transmitter, meter, and connecting wiring.

- C. Flow Sensor: Insertion-type turbine or paddle-wheel element with corrosion-resistant-metal body and transmitter.
 - 1. Pressure Rating: 125 psig (860 kPa).
 - 2. Temperature Range: 40 to 250 deg F (5 to 121 deg C).
- D. Meter: Solid-state integrating type.
 - 1. Data Output: Six-digit electromechanical counter with readout in kilowatts per hour or British thermal units (joules).
 - 2. Accuracy: Plus or minus 1 percent.
 - 3. Battery Pack: Five-year lithium battery.
- E. Strainer: Full size of main line piping.

PART 3 - EXECUTION

3.1 THERMOMETER APPLICATIONS

- A. Install liquid-in-glass thermometers in the following locations:
 - 1. Inlet and outlet of each hydronic zone.
 - 2. Inlet and outlet of each boiler and air cooled chiller.
 - 3. Inlet and outlet of each hydronic coil in air-handling units and built-up central systems.
 - 4. Inlet and outlet of each mixing valve.
- B. Install direct-mounting, vapor-actuated dial thermometers in locations where temperature sensing bulb is more than 5 feet from viewing position.
- C. Install remote-mounting, vapor-actuated dial thermometers in cabinets and panels.
- D. Install liquid-filled-case-type, bimetallic-actuated dial thermometers at suction and discharge of each pump.
- E. Provide the following temperature ranges for thermometers:
 - 1. Heating Hot Water: 30 to 240 deg F, with 2-degree scale divisions.
 - 2. Chilled Water: 0 to 100 deg F, with 2-degree scale divisions.

3.2 GAGE APPLICATIONS

- A. Install liquid-filled-type pressure gauges at suction and discharge of each pump and all other services.

3.3 INSTALLATIONS

- A. Install direct-mounting thermometers and adjust vertical and tilted positions.
- B. Install remote-mounting dial thermometers on panel, with tubing connecting panel and thermometer bulb supported to prevent kinks. Use minimum tubing length.
- C. Install thermowells with socket extending a minimum of 2 inches into fluid and in vertical position in piping tees where thermometers are indicated.
- D. Install direct-mounting pressure gages in piping tees with pressure gage located on pipe at most readable position.
- E. Install remote-mounting pressure gages on panel.

- F. Install needle-valve and snubber fitting in piping for each pressure gage for fluids (except steam).
- G. Install needle-valve and syphon fitting in piping for each pressure gage for steam.
- H. Install test plugs in tees in piping.
- I. Install flow indicators, in accessible positions for easy viewing, in piping systems.
- J. Assemble and install connections, tubing, and accessories between flow-measuring elements and flowmeters as prescribed by manufacturer's written instructions.
- K. Install flowmeter elements in accessible positions in building chilled water piping systems.
- L. Install differential-pressure-type flowmeter elements with at least minimum straight lengths of pipe upstream and downstream from element as prescribed by manufacturer's written instructions.

3.4 CONNECTIONS

- A. Install meters and gages adjacent to machines and equipment to allow service and maintenance for meters, gages, machines, and equipment.

3.5 ADJUSTING

- A. Calibrate meters according to manufacturer's written instructions, after installation.
- B. Adjust faces of thermometers and gages to proper angle for best visibility.

END OF SECTION

SECTION 23 05 23

GENERAL-DUTY VALVES FOR HVAC PIPING

PART 1 - GENERAL

1.1 RELATED DOCUMENTS

- A. Drawings and general provisions of the Contract, including General and Supplementary Conditions and Division 01 Specification Sections, apply to this Section.
- B. Section 01 81 13 "Sustainable Design Requirements – LEED v4 for Building Design & Construction – New Construction" for sustainable design requirements and detailed sustainable design submittal requirements.
- C. Section 01 74 19 "Construction and Demolition Waste Management and Disposal" for disposal of construction, demolition and packaging waste disposal requirements.

1.2 SUMMARY

- A. Section Includes:
 - 1. Bronze gate valves.
 - 2. Bronze globe valves.
 - 3. Bronze swing check valves.
 - 4. Bronze needle valves.
 - 5. Iron gate valves.
 - 6. Iron globe valves.
 - 7. Iron swing check valves.
 - 8. Iron grooved-end check valves.
 - 9. Bronze ball valves.
 - 10. Steel ball valves.
 - 11. Cast iron plug valves.
 - 12. Calibrated balancing valves.
 - 13. Electric valve actuators.
- B. Related Sections:
 - 1. Division 23 HVAC piping Sections for specialty valves applicable to those Sections only.
 - 2. Division 23 Section "Identification for HVAC Piping and Equipment" for valve tags and schedules.
- C. Sustainable Building Requirements:
 - 1. The Owner requires the Contractor to implement practices and procedures to meet the project's environmental performance goals, which include achieving LEED version 4 **Certified** level Certification. Specific project goals that may impact this area of work include: use of recycled-content materials; use of locally-manufactured materials; use of low-emitting materials; construction waste recycling; and the implementation of a construction indoor air quality management plan. The Contractor shall ensure that the requirements related to these goals, as defined in the Articles below, are implemented to the fullest

extent. Substitutions, or other changes to the work proposed by the Contractor or their Subcontractors, shall not be allowed if such changes compromise the aforementioned environmental goals and LEED certification.

1.3 DEFINITIONS

- A. CWP: Cold working pressure.
- B. EPDM: Ethylene propylene copolymer rubber.
- C. NBR: Acrylonitrile-butadiene, Buna-N, or nitrile rubber.
- D. NRS: Nonrising stem.
- E. OS&Y: Outside screw and yoke.
- F. RS: Rising stem.
- G. SWP: Steam working pressure.
- H. PTFE: Polytetrafluoroethylene plastic.
- I. WOG: Water, oil, or gas.
- J. TFE: Tetrafluoroethylene plastic

1.4 SUBMITTALS

- A. Product Data:
 - 1. For each type of valve indicated. Include body, seating, and trim materials; valve design; pressure and temperature classifications; end connections; arrangement; dimensions; and required clearances. Include list indicating valve and its application. Include rated capacities; shipping, installed, and operating weights; furnished specialties; and accessories.
 - 2. For each type of special duty valve indicated include flow and pressure drop curves based on manufacturer's testing for diverting fittings, calibrated balancing valves and automatic flow control valves.
- B. Maintenance Data.
 - 1. Furnish maintenance manuals as specified in Division 1.

1.5 QUALITY ASSURANCE

- A. Source Limitations for Valves: Obtain each type of valve from single source from single manufacturer.
- B. ASME Compliance:
 - 1. ASME B16.10 and ASME B16.34 for ferrous valve dimensions and design criteria.
 - 2. ASME B31.1 for power piping valves.
 - 3. ASME B31.9 for building services piping valves.
- C. Standards: If any item in this specification, as furnished by the contractor is manufactured in a location which does not certify ASME / ANSI standards, the contractor is to pay the owner for all expenses incurred by the owner for an outside testing company to confirm such compliances.
- D. To assure uniformity and compatibility, all grooved end valves and adjoining couplings and fittings shall be supplied by Victaulic.

1.6 DELIVERY, STORAGE, AND HANDLING

- A. Prepare valves for shipping as follows:
 - 1. Protect internal parts against rust and corrosion.
 - 2. Protect threads, flange faces, grooves, and weld ends. with wooden flange covers or with screwed plugs / caps as required.
 - 3. Set gate, and globe valves closed to prevent rattling.
 - 4. Set ball and plug valves open to minimize exposure of functional surfaces.
 - 5. Set butterfly valves closed or slightly open.
 - 6. Block check valves in either closed or open position.
 - 7. Protect instrumentation from damage.
 - 8. Clean flanges and exposed metal surfaces and treat with anti-corrosive compound before assembly and testing.
- B. Use the following precautions during storage:
 - 1. Maintain valve end protection.
 - 2. Store valves indoors and maintain at higher than ambient dew point temperature. If outdoor storage is necessary, store valves off the ground in watertight enclosures.
- C. Use sling to handle large valves; rig sling to avoid damage to exposed parts. Do not use handwheels or stems as lifting or rigging points

1.7 WARRANTY

- A. General warranty: Special warranty specified in this article shall not deprive the owner of the other rights Owner may have under other provisions of the Contract Documents and shall be in addition to and run concurrent with other warranties made by Contractor under requirements of the Contract Documents.

PART 2 - PRODUCTS

2.1 GENERAL REQUIREMENTS FOR VALVES

- A. Refer to HVAC valve schedule articles for applications of valves (Part 3 "Valve Applications Schedule").
- B. Valve Pressure and Temperature Ratings: Not less than indicated and as required for system pressures and temperatures.
- C. Valve Sizes: Same as upstream piping unless otherwise indicated.
- D. Valve Actuator Types:
 - 1. Gear Actuator: For quarter-turn valves NPS 8 (DN 200) and larger.
 - 2. Handwheel: For valves other than quarter-turn types.
 - 3. Handlever: For quarter-turn valves NPS 6 (DN 150) and smaller except plug valves.
 - 4. Wrench: For plug valves with square heads. Furnish Owner with 1 wrench for every 10 plug valves, for each size square plug-valve head.
 - 5. Chainwheel: Device for attachment to valve handwheel, stem, or other actuator; of size and with chain for mounting height, as indicated in the "Valve Installation" Article.
 - 6. Electric motor: As indicated on the drawings.

- E. Valves in Insulated Piping: With 2-inch (50-mm) stem extensions and the following features:
 - 1. Gate Valves: With rising stem.
 - 2. Ball Valves: With extended operating handle of non-thermal-conductive material, and protective sleeve that allows operation of valve without breaking the vapor seal or disturbing insulation.
- F. Valve-End Connections:
 - 1. Flanged: With flanges according to ASME B16.1 for iron valves
 - 2. Flanged: With flanges according to ASME B16.24 for bronze valves.
 - 3. Grooved: With grooves according to AWWA C606.
 - 4. Solder Joint: With sockets according to ASME B16.18.
 - 5. Threaded: With threads according to ASME B1.20.1.
- G. Valve Bypass and Drain Connections: MSS SP-45.

2.2 VALVE DESCRIPTIONS

- A. BRONZE GATE VALVES, 2 INCHES AND SMALLER, MSS SP-80 TYPE 1
 - 1. Manufacturers -Bronze gate valves
 - a. Crane Co.; Crane Valve Group; Jenkins Valves
 - b. Crane Co; Crane Valve Group; Crane Valves
 - c. Crane Co; Crane Valve Group; Stockham Division.
 - d. Grinnell Corporation
 - e. Walworth Company
 - f. NIBCO Inc.
 - 2. Class 150 psi steam, 300 psi cold working pressure (CWP)
 - a. ASTM B 62 cast-bronze body and bonnet
 - b. Union bonnet
 - c. Solid-bronze wedge
 - d. Copper-silicon alloy rising stem
 - e. Teflon-impregnated packing with bronze packing nut
 - f. Threaded (steel piping) end connection –SCHEDULE VALVE NO. 0101
 - g. Soldered (copper piping) end connection – SCHEDULE VALVE NO. 0102
 - h. Aluminum or malleable-iron handwheel
- B. BRONZE GLOBE VALVES, 2 INCHES AND SMALLER, MSS SP-80 TYPE 3
 - 1. Manufactures-Bronze globe valves
 - a. Crane Co; Crane Valve Group; Jenkins Valves
 - b. Crane Co; Crane Valve Group; Crane Valves
 - c. Crane Co; Crane Valve Group; Stockham Division.
 - d. Grinnell Corporation
 - e. Walworth Company
 - f. NIBCO Inc.
 - 2. Class 150 psi steam, 300 psi cold working pressure (CWP)
 - a. ASTM B 62 cast-bronze body and bonnet
 - b. Union bonnet
 - c. Stainless steel disc
 - d. Stainless steel seat
 - e. Copper-silicon alloy rising stem
 - f. Teflon-impregnated packing with bronze packing nut
 - g. Threaded end connection
 - h. Aluminum or malleable-iron handwheel
 - i. SCHEDULE VALVE NO. 0201

- C. BRONZE SWING CHECK VALVES, 2 INCHES AND SMALLER, MSS SP-80
 - 1. Manufacturers - Bronze check valves, Horizontal and Vertical
 - a. Horizontal
 - 1) Crane Co.; Crane Valve Group; Jenkins Valves
 - 2) Crane Co.; Crane Valve Group; Crane Valves
 - 3) Crane Co.; Crane Valve Group; Stockham Division
 - 4) Grinnell Corporation
 - 5) Walworth Company
 - 6) NIBCO Inc.
 - b. Vertical
 - 1) Crane Co.; Crane Valve Group; Jenkins Valves
 - 2) Crane Co.; Crane Valve Group; Crane Valves
 - 3) Cincinnati Valve Co
 - 2. Class 150 pi steam, 300 psi cold working pressure (CWP)
 - a. ASTM B 62 cast-bronze body and cap
 - b. "Y" pattern
 - c. Stainless steel free floating hinge pin
 - d. Threaded cap
 - e. Regrinding seat
 - f. Bronze disc
 - g. Threaded (steel piping) end connection - SCHEDULE VALVE NO. 0301
 - h. Soldered (copper piping) end connection - SCHEDULE VALVE NO. 0302
- D. Bronze needle valves, 1/8 inch to 3/4 inch, MSS SP-80
 - 1. Manufacturers - Bronze Needle Valves
 - a. Crane Co.; Crane Valve Group; Jenkins Valves
 - b. Crane Co.; Crane Valve Group; Stockham Division.
 - 2. Class 200 psi steam, 400 psi cold working pressure (CWP)
 - a. ASTM B 62 cast-bronze body and bonnet
 - b. Screwed bonnet
 - c. Bronze ASTM B 150 rising stem & needle
 - d. Integral bronze seat
 - e. Graphite packing with bronze packing nut
 - f. Threaded end connection
 - g. Globe or angle pattern
 - h. Aluminum or malleable-iron handwheel
 - i. SCHEDULE VALVE NO. 0501
- E. IRON GATE VALVES
 - 1. Manufacturers - Iron gate valves
 - a. Crane Co.; Crane Valve Group; Jenkins Valves
 - b. Crane Co.; Crane Valve Group; Crane Valves
 - c. Crane Co.; Crane Valve Group; Stockham Division
 - d. Grinnell Corporation
 - e. Cincinnati Valve Co.
 - f. NIBCO Inc.
 - 2. 2 inch and smaller, MSS SP 25, MSS SP-70 type 1
 - a. Class 125 psi steam, 200 psi cold working pressure (CWP)
 - 1) ASTM A 126 class B cast-iron body and bonnet
 - 2) Bolted bonnet
 - 3) Outside screw & yoke
 - 4) Rising stem
 - 5) Solid bronze disc

- 6) Bronze stem
- 7) Renewable bronze seat rings
- 8) Threaded end connection
- 9) Non-asbestos packing and gaskets
- 10) Aluminum or malleable-iron handwheel
- 11) SCHEDULE VALVE NO. 0601
- b. Class 250 psi steam, 500 psi cold working pressure (CWP)
 - 1) ASTM A 126 class B cast-iron body and bonnet
 - 2) Bolted bonnet
 - 3) Outside screw & yoke
 - 4) Rising stem
 - 5) Solid bronze disc
 - 6) Steel stem
 - 7) Renewable bronze seat rings
 - 8) ANSI 250 flat face flanged ends
 - 9) Non-asbestos packing and gaskets
 - 10) Aluminum or malleable-iron handwheel
 - 11) SCHEDULE VALVE NO. 0602
3. 2 1/2 inch to 12 inch, MSS SP 25, MSS SP-70 type 1
 - a. Class 125 psi steam, 200 psi cold working pressure (CWP)
 - 1) ASTM A 126 class B cast-iron body and bonnet
 - 2) Bolted bonnet
 - 3) Outside screw & yoke
 - 4) Rising stem
 - 5) Solid bronze disc
 - 6) Steel stem
 - 7) Renewable bronze seat rings
 - 8) ANSI 125 flat face flanged ends
 - 9) Non-asbestos packing and gaskets
 - 10) Aluminum or malleable-iron handwheel
 - 11) SCHEDULE VALVE NO. 0611
 - b. Class 250 psi steam, 500 psi cold working pressure (CWP)
 - 1) ASTM A 126 class B cast-iron body and bonnet
 - 2) Bolted bonnet
 - 3) Outside screw & yoke
 - 4) Rising stem
 - 5) Solid bronze disc
 - 6) Steel stem
 - 7) Renewable bronze seat rings
 - 8) ANSI 250 flat face flanged ends
 - 9) Non-asbestos packing and gaskets
 - 10) Aluminum or malleable-iron handwheel
 - 11) SCHEDULE VALVE NO. 0612

F. IRON GLOBE VALVES

1. Manufacturers - Iron globe valves
 - a. Crane Co.; Crane Valve Group; Jenkins Valves
 - b. Crane Co.; Crane Valve Group; Crane Valves
 - c. Crane Co.; Crane Valve Group; Stockham Division
 - d. Grinnell Corporation
 - e. Cincinnati Valve Co.
 - f. NIBCO Inc.
2. 3 inches to 10 inches, MSS SP-85

- a. Class 125 psi steam, 200 psi cold working pressure (CWP)
 - 1) ASTM A 126 class B cast-iron body and bonnet
 - 2) Bolted bonnet
 - 3) Outside screw & yoke
 - 4) Rising stem
 - 5) 6 inch and smaller: solid bronze disc
 - 6) 8 inch and larger: cast iron disc with bronze facing
 - 7) Bottom guided disc
 - 8) Brass alloy stem
 - 9) Renewable bronze seat
 - 10) ANSI 125 flat face flanged ends
 - 11) Non-asbestos packing and gaskets
 - 12) Aluminum, steel, or cast iron handwheel
 - 13) SCHEDULE VALVE NO. 0701
- b. Class 250 psi steam, 500 psi cold working pressure (CWP)
 - 1) ASTM A 126 class B cast-iron body and bonnet
 - 2) Bolted bonnet
 - 3) Outside screw & yoke
 - 4) Rising stem
 - 5) 3 inch and smaller: solid bronze disc
 - 6) 6 inch and larger: cast iron disc with bronze facing
 - 7) Bottom guided disc
 - 8) Brass alloy stem
 - 9) Renewable bronze seat
 - 10) ANSI 250 flat face flanged ends
 - 11) Non-asbestos packing and gaskets
 - 12) Aluminum, steel, or cast iron handwheel
 - 13) SCHEDULE VALVE NO. 0702

G. IRON SWING CHECK VALVES

- 1. Manufacturers:
 - a. Crane Co.; Crane Valve Group; Jenkins Valves
 - b. Crane Co.; Crane Valve Group; Crane Valves
 - c. Crane Co.; Crane Valve Group; Stockham Division
 - d. Grinnell Corporation
 - e. Cincinnati Valve Co.
 - f. NIBCO Inc.
- 2. 2½ inch to 12 inch, ASME B16.10
 - a. Class 125 psi steam, 200 psi cold working pressure (CWP)
 - 1) Cast iron body and cap
 - 2) Replaceable bronze seat ring
 - 3) 6 inch and smaller: solid bronze disc
 - 4) 8 inch and larger: cast iron disc with bronze facing
 - 5) Replaceable brass hinge pin
 - 6) Flanged ends
 - 7) SCHEDULE VALVE NO. 0811
 - b. Class 250 psi steam, 500 psi cold working pressure (CWP)
 - 1) Cast iron body and cap, ASTM A126 class B
 - 2) Screwed in bronze body seat ring
 - 3) 3 inch and smaller: solid bronze disc
 - 4) 4 inch and larger: cast iron disc with bronze facing
 - 5) Stainless steel hinge pin
 - 6) Flanged ends

7) SCHEDULE VALVE NO. 0812

H. IRON, GROOVED-END SWING CHECK VALVES

1. Manufacturers: Subject to compliance with requirements, [provide products by one of the following] [available manufacturers offering products that may be incorporated into the Work include, but are not limited to, the following]:
 - a. Victaulic Company.
2. Description:
 - a. CWP Rating: NPS 2 through NPS 12: 300 psig (2070 kPa).
 - b. Body Material: ASTM A 536, ductile iron.
 - c. Seal: EPDM.
 - d. Disc: Spring operated, ductile iron or stainless steel.
 - e. Victaulic Styles 716H, 716, 779

I. BRONZE BALL VALVES, 3 INCHES AND SMALLER

1. Manufacturers - Bronze ball valves
 - a. Conbraco Industries Inc.; Apollo Division
 - b. Crane Co.; Crane Valve Group; Jenkins Valves
 - c. Crane Co.; Crane Valve Group; Stockham Division
 - d. Jamesbury Inc.
 - e. Milwaukee Valve Company
2. 2 piece, class 150 psi steam, 600 psi cold working pressure (CWP), standard port
 - a. ASTM B584 cast bronze body
 - b. Stainless steel ball and stem
 - c. Chrome plated brass ball with brass stem
 - d. Blow out proof stem design
 - e. PTFE seats
 - f. PTFE stem packing
 - g. Zinc plated steel lever with vinyl covered grip
 - h. Threaded ends - SCHEDULE VALVE NO. 1811
 - i. Solder ends - SCHEDULE VALVE NO. 1812
3. 3 piece, class 150 psi steam, 600 psi cold working pressure (CWP), full port
 - a. ASTM B584 cast bronze body
 - b. Stainless steel ball and stem
 - c. Chrome plated brass ball with brass stem
 - d. Blow out proof stem design
 - e. PTFE seats
 - f. PTFE stem packing
 - g. Zinc plated steel lever with vinyl covered grip
 - h. Threaded ends
 - i. SCHEDULE VALVE NO. 1821

J. CARBON STEEL BALL VALVES

1. Manufacturers - Steel ball valves
 - a. Conbraco Industries Inc.; Apollo Division
 - b. Crane Co.; Crane Valve Group; Stockham Division
 - c. Jamesbury Inc.
 - d. Cooper Cameron Corp.; Cooper Cameron Valves Div.
 - e. Milwaukee Valve Company
2. 2 piece, class 150 psi steam, 3000 psi cold working pressure (CWP), full port, 2_inches and smaller
 - a. ASTM A108 carbon steel body

- b. Stainless steel ball and stem
 - c. ASTM A108 chrome plated ball and stem
 - d. Blow out proof stem design
 - e. PTFE seats
 - f. PTFE stem packing
 - g. Zinc plated steel lever with vinyl covered grip
 - h. Threaded ends
 - i. SCHEDULE VALVE NO. 1901
3. 3 piece, class 150 psi steam, 1000 psi cold working pressure (CWP), full port, 2 inches and smaller
- a. ASTM A108 carbon steel body
 - b. Stainless steel ball and stem
 - c. ASTM A108 chrome plated ball and stem
 - d. Blow out proof stem design
 - e. PTFE seats
 - f. PTFE stem packing
 - g. Zinc plated steel lever with vinyl covered grip
 - h. Threaded ends – SCHEDULE VALVE NO. 1911
 - i. Socket weld ends – SCHEDULE VALVE NO. 1912
4. ANSI flanged, class 150 psi steam, 285 psi cold working pressure (CWP), reduced port, 2½ inches to 10 inches
- a. ASTM A216 WCB cast carbon steel body
 - b. ASTM A216 WCB chrome plated ball
 - c. ASTM A108 carbon steel stem
 - d. Blow out proof stem design
 - e. PTFE seats
 - f. Graphite stem packing
 - g. Galvanized pipe lever
 - h. Raised face flange ends
 - i. SCHEDULE VALVE NO. 1921
5. ANSI flanged, class 300 psi steam, 740 psi cold working pressure (CWP), reduced port, 3 inches to 10 inches
- a. ASTM A216 WCB cast carbon steel body
 - b. ASTM A216 WCB chrome plated ball
 - c. ASTM A108 carbon steel stem
 - d. Blow out proof stem design
 - e. PTFE seats
 - f. Graphite stem packing
 - g. Galvanized pipe lever
 - h. Raised face flange ends
 - i. SCHEDULE VALVE NO. 1941
- K. CAST IRON PLUG VALVES
1. Manufacturers - Cast iron plug valves
- a. Nordstrom Valve Inc.
 - b. Walworth Company
 - c. R&M Energy systems (Tomball Tx)
 - d. Olson Technologies; Homestead Div.
2. 2 inch and smaller, MSS SP 25, MSS SP-78
- a. 200 psi cold working pressure (CWP)
 - 1) ASTM A 126 gray iron body
 - 2) Regular pattern
 - 3) Screwed gland

- 4) Buna-N gland and stem seals
- 5) Gray iron lubricated tapered plug
- 6) Carbon steel sealant fitting
- 7) 1 year supply lubricant per valve
- 8) 1 lubricating gun with 15,000 psi gauge and 12 inch connection hose per 10 valves
- 9) 1 wrench operator per 10 valves
- 10) Threaded end connection
- 11) SCHEDULE VALVE NO. 2001
- b. 400 psi cold working pressure (CWP)
 - 1) ASTM A 126 gray iron body
 - 2) Short pattern
 - 3) Screwed gland
 - 4) Buna-N gland and stem seals
 - 5) Gray iron lubricated tapered plug
 - 6) Carbon steel sealant fitting
 - 7) 1 year supply lubricant per valve
 - 8) 1 lubricating gun with 15,000 psi gauge and 12 inch connection hose per 10 valves
 - 9) 1 wrench operator per 10 valves
 - 10) Threaded end connection
 - 11) SCHEDULE VALVE NO. 2002
3. 2 1/2 inch to 4 inch, MSS SP 25, MSS SP-78
 - a. 200 psi cold working pressure (CWP)
 - 1) ASTM A 126 gray iron body
 - 2) Regular pattern
 - 3) Screwed gland
 - 4) Buna-N gland and stem seals
 - 5) Gray iron lubricated tapered plug
 - 6) Carbon steel sealant fitting
 - 7) 1 year supply lubricant per valve
 - 8) 1 lubricating gun with 15,000 psi gauge and 12 inch connection hose per 10 valves
 - 9) 1 wrench operator per 10 valves
 - 10) ANSI 125 flanged ends
 - 11) SCHEDULE VALVE NO. 2011
 - b. 400 psi cold working pressure (CWP)
 - 1) ASTM A 126 gray iron body
 - 2) Short pattern
 - 3) Screwed gland
 - 4) Buna-N gland and stem seals
 - 5) Gray iron lubricated tapered plug
 - 6) Carbon steel sealant fitting
 - 7) 1 year supply lubricant per valve
 - 8) 1 lubricating gun with 15,000 psi gauge and 12 inch connection hose per 10 valves
 - 9) 1 wrench operator per 10 valves
 - 10) ANSI 250 flanged ends
 - 11) SCHEDULE VALVE NO. 2012
4. 5 and 6 inch, MSS SP 25, MSS SP-78
 - a. 200 psi cold working pressure (CWP)

- 1) ASTM A 126 gray iron body
 - 2) Short pattern
 - 3) Bolted gland
 - 4) Buna-N gland and stem seals
 - 5) Gray iron lubricated tapered plug
 - 6) Carbon steel sealant fitting
 - 7) 1 year supply lubricant per valve
 - 8) 1 lubricating gun with 15,000 psi gauge and 12 inch connection hose per 10 valves
 - 9) 1 wrench operator per 10 valves
 - 10) ANSI 125 flanged ends
 - 11) SCHEDULE VALVE NO. 2021
 - b. 400 psi cold working pressure (CWP)
 - 1) ASTM A 126 gray iron body
 - 2) Regular pattern
 - 3) Bolted gland
 - 4) Buna-N gland and stem seals
 - 5) Gray iron lubricated tapered plug
 - 6) Carbon steel sealant fitting
 - 7) 1 year supply lubricant per valve
 - 8) 1 lubricating gun with 15,000 psi gauge and 12 inch connection hose per 10 valves
 - 9) 1 wrench operator per 10 valves
 - 10) ANSI 250 flanged end
 - 11) SCHEDULE VALVE NO. 2022
- L. IRON BUTTERFLY VALVES-Not Used
- M. SPRING LOADED LIFT DISC CHECK VALVES
1. Manufacturers - Spring loaded lift disc check valves.
 - a. Mueller Steam Specialty Co.
 - b. Milwaukee Valve Co.
 - c. Titan Flow Control, Inc.
 2. 2 inch and smaller
 - a. 200 psi cold working pressure (CWP) up to 150°F
 - 1) Cast iron body and cap
 - 2) Screwed cap
 - 3) EPDM seal
 - 4) Stainless steel stem
 - 5) Stainless steel spring
 - 6) Brass disc
 - 7) Threaded ends
 - 8) SCHEDULE VALVE NO. 2401
 - b. 400 psi cold working pressure (CWP) up to 150°F
 - 1) Bronze body and cap
 - 2) Screwed cap
 - 3) EPDM seal
 - 4) Stainless steel stem
 - 5) Stainless steel spring
 - 6) Brass disc
 - 7) Threaded ends
 - 8) SCHEDULE VALVE NO. 2402
 3. 2½ inch to 12 inch

- a. 200 psi cold working pressure (CWP) up to 150°F
 - 1) ASTM A126 grade B cast iron, globe style, body
 - 2) ASTM B62 bronze disc and seat
 - 3) Stainless steel spring
 - 4) Silicon bronze guide pins and bushings
 - 5) ANSI class 125 flanged end connections
 - 6) SCHEDULE VALVE NO. 2411
- b. 500 psi cold working pressure (CWP) up to 150°F
 - 1) ASTM A126 grade B cast iron, globe style, body
 - 2) ASTM B62 bronze disc and seat
 - 3) Stainless steel spring
 - 4) Silicon bronze guide pins and bushings
 - 5) ANSI class 250 flanged end connections
 - 6) SCHEDULE VALVE NO. 2413

N. CIRCUIT BALANCING VALVES

1. Manufacturers: Taco fixed port venturi style balancing valves:
 - a. 2" and Smaller Sizes: 300 psi (2065 kPa), threaded or soldered non-ferrous bronze body, with dual Schrader style pressure ports. All wetted parts shall be of brass construction. Valves shall have built in drain ports. Internal seats shall be Teflon. Valves shall have memory stop and shall be Taco Accu-Flo.
 - b. 2-1/2" and Larger Sizes: 125 psi ,flanged ends, Cast iron body, all other metal parts of brass, EPDM O-ring seals, dual Schrader style pressure ports. Valves shall have memory stop and shall be Taco Accu-Flo.

2.3 Electric MOTOR ACTUATORS

1. Manufacturers - Electric valve actuators
 - a. Limitorque Corporation
 - b. Rotork Controls, Inc.
 - c. Belimo Air Controls, Inc.
 - d. EIM Company, Inc.
- B. Motor valve operators.
- C. Provide as follows:
 1. Mount operators on side or top of valve at factory or at site under manufacturer's supervision. Provide gear operated single or double reduction. For 90 deg (1/4 turn) application, adjustable mechanical stops shall prevent travel of more than 90 deg
 2. Grease or oil lubricated.
 3. 120 Volt, 1 phase, 60 hertz
 4. Control circuit: 24 volt, transformer as required.
 5. Assembly:
 - a. Motor shall be high speed, high torque, totally enclosed non-ventilated, Class B or F insulation and operational at up to 10 percent above or below nominal voltage. Motor shall be prelubricated, anti-friction bearing type with thermal overload protection.
 - b. Limit switches shall be integral to the unit. Gearing shall be bronze or stainless steel. Steel switches shall be fully adjustable and shall trip anywhere between full open and full close, as required. Switches shall

- be heavy duty, open contact type with rotary wiping action. Provide minimum spare contacts 2 normally open, 2 normally closed.
- c. Torque switch shall have torque protection either direction, fully adjustable and shall shut off actuator motor when a predetermined amount of torque is reached.
 - d. Stem nut shall be high tensile bronze or material compatible to the valve stem and shall be constructed for easy removal without disassembling gear case.
 - e. Handwheel for manual operation: Handwheel shall declutch automatically when motor is energized. Rimpull shall not exceed a maximum of 80 lb. Handwheel shall be similar to Limitorque SMB and SMC.
6. For open/closed operation: All valves shall have integral control package including control transformer with fused secondary, motor reversing contactor (mechanically interlocked), limit switch compartment heater and terminal strip.
 - a. Indicating lights shall be:
 - 1) Red light glows when valve closed.
 - 2) Green light glows when valve open.
 - 3) Intermediate position indication.
 - b. Pushbutton station: Provide selector switch if required and momentary or maintained contacts as required.
 7. For modulating service shall be controlled by analog signal 4-20 ma DC with momentary pushbuttons.
 - a. Controls shall be mounted inside the actuator.
 - b. Provide single phase power supply:
 - 1) Comparator circuit module.
 - 2) Mechanical dial position indicator with 1,000 ohm potentiometer feedback.
 - 3) 2 position (auto/manual) selector switch.
 - 4) Limit switch compartment heater.
 - 5) Motor: 2100 rpm D.C. in lieu of A.C.; class F insulation; 20 percent run valve duty.
 - 6) Mounted and wired, similar to Limitorque Modutronic 10A and 10B.
 8. Closing time:
 - a. Gate shall be 12 inches per minute, minimum 1 minute.
 - b. Globe shall be 4 inches per minute, minimum 1 minute.
 9. Provide remote open-close buttons and open-close indicating lights for installation on control board in Division 15 Section "Automatic Controls System".
 10. Final field adjustment of valve operation shall be made by manufacturer's representative.

PART 3 - EXECUTION

3.1 EXAMINATION

- A. Examine piping system for compliance with requirements for installation tolerances and other conditions affecting performance.

1. Proceed with installation only after unsatisfactory conditions have been corrected.
- B. Examine valve interior for cleanliness, freedom from foreign matter, and corrosion. Remove special packing materials, such as blocks, used to prevent disc movement during shipping and handling.
- C. Operate valves in positions from fully open to fully closed. Examine guides and seats made accessible by such operations.
- D. Examine threads on valve and mating pipe for form and cleanliness.
- E. Examine mating flange faces for conditions that might cause leakage. Check bolting for proper size, length, and material. Verify that gasket is of proper size, that its material composition is suitable for service, and that it is free from defects and damage.
- F. Do not attempt to repair defective valves; replace with new valves.
- G. Examine grooved ends for conditions that might cause leakage. Ends should be free from indentations or projections in the area from valve end to groove

3.2 VALVE INSTALLATION

- A. Install valves with unions flanges, or Victaulic couplings (on authorized systems) at each piece of equipment arranged to allow service, maintenance, and equipment removal without system shutdown.
- B. Locate valves for easy access and provide separate support where necessary.
- C. Install valves in horizontal piping with stem at or above center of pipe.
- D. Install valves in position to allow full stem movement.
- E. Install check valves for proper direction of flow and as follows:
 1. Swing Check Valves: In horizontal position with hinge pin level.
 2. Center-Guided and Plate-Type Check Valves: In horizontal or vertical position, between flanges.
 3. Lift Check Valves: With stem upright and plumb.

3.3 ADJUSTING

- A. Adjust or replace valve packing after piping systems have been tested and put into service but before final adjusting and balancing. Replace valves if persistent leaking occurs.

3.4 GENERAL REQUIREMENTS FOR VALVE APPLICATIONS

- A. General-Duty Valve Applications: Unless otherwise indicated, use the following valve types:
 1. Shutoff Service except Steam: Ball, or gate valves.
 2. Shutoff service, Steam: gate valves.
 3. Throttling Service except Steam: Ball, or plug valves.
 4. Throttling Service, Steam: Globe valves.
- B. If valves with specified SWP classes or CWP ratings are not available, the same types of valves with higher SWP classes or CWP ratings may be substituted.

- C. Install shutoff duty valves at each branch connection to supply mains, at supply connection to each piece of equipment, unless only one piece of equipment is connected in the branch line. Install throttling duty valves at each branch connection to return mains, at return connections to each piece of equipment, and elsewhere as indicated.
- D. Install Y-pattern multi-turn globe style balancing valves in the return water line of each heating or cooling element and elsewhere as required to facilitate system balancing.
- E. Install spring loaded check valves at each pump discharge and elsewhere as required to control flow direction.

3.5 VALVE SCHEDULE

- A. The valve numbers listed in the tables below correspond to the valve numbers listed in the products section for each valve type.
- B. Table abbreviations
 - 1. CHW – Chilled water
 - 2. HW – hot water
 - 3. LPS – low pressure steam
 - 4. MPS – medium pressure steam, classified as high pressure steam, however the requirements may vary
 - 5. HPS – high pressure steam
 - 6. The pressures are listed next to the service (i.e. <125 psig is less than 125 psig; 126-250 is between 126 and 250 psig, >251 is greater than 251 psig)..
- C. Gate valves

Service pressure	< 2"thread	< 2"solder	< 2"flange	> 2"flange	< 2"weld	> 2"weld
CHW< 125	0101 0601	0102	na	0611	na	na
HW < 125	0101 0601	0102	na	0611	na	na
LPS < 15	0101 0601	na	na	0611	na	na
MPS 16-125	0101 0601	na	na	0611	na	na
HPS 126-250	0111	na	na	1411	1102	1412
LPR	0101 0601	na	na	0611	na	na
HPR	0111	na	na	1411	1102	1412
MU	0101 0601	0102	na	0611	na	na

- D. Globe valves

Service pressure	< 2"thread	< 2"solder	< 2"flange	> 2"flange	< 2"weld	> 2"weld
CHW< 125	0201	na	na	0701	na	na
HW < 125	0201	na	na	0701	na	na
LPS < 15	0201	na	na	0701	na	na

MPS 16-125	0201	na	na	1501	na	na
HPS 126-250	0211 1201	na	na	1511	1202	1512
LPR	0201	na	na	0701	na	na
HPR	0211	na	na	1511	1202	1512
MU	0201	na	na	0701	na	na

E. Check valves

Service pressure	< 2" thread	< 2" solder	< 2" flange	> 2" flange	< 2" weld	> 2" weld	>2" grooved
CHW < 125	0301	0302	na	0811	na	na	716/779/W715
HW < 125	0301	0302	na	0811	na	na	
LPS < 15	0301	na	na	0811	na	na	
MPS 16-125	0301	na	na	1601	na	na	
HPS 126-250	0311 0801	na	na	1611	1302	1612	
LPR	0301	na	na	0811	na	na	
HPR	0311	na	na	1611	1302	1612	
MU	0301	0302	na	0811	na	na	

F. Angle valves

Service pressure	< 2" thread	< 2" solder	< 2" flange	> 2" flange		
CHW < 125	0401	na	na	0901		
HW < 125	0401	na	na	0901		
LPS < 15	0401	na	na	0901		
MPS 16-125	na	na	na	0901		
HPS 126-300	na	na	na	na		
LPR	0401	na	na	0901		
HPR	na	na	na	na		
MU	0401	na	na	0901		

G. Needle valves

Service pressure	< 3/4" thread					
CHW	0501					
HW	0501					
MU	0501					

H. Stop check valves

Service pressure				> 2" flange		> 2" weld
LPS < 15				1001		1702
MPS 16-125				1701		1702

HPS 126-300				1701		1702
-------------	--	--	--	------	--	------

I. Ball valves

Service pressure	< 3"thread	< 3"solder		> 2"flange	< 2" weld	
CHW < 125	1811 1821 1901	1812		1921	1912	
HW < 125	1811 1821 1901	1812		1921	1912	
LPS < 15	1811 1821 1901	na		1921	1912	
LPR	1811 1821 1901	1812		1921	1912	
MU	1811 1821 1901	1812		1921	na	

J. Plug valves

Service pressure	< 2"thread	2½" - 4"	5" - 6"	8" - 12"	8" - 24"	
CHW < 200	2001	2011	2021	2031	na	
HW < 125	2001	2011	2021	2031	na	

K. Butterfly valves-Not Used

L. High performance butterfly valves-Not Used

M. Spring loaded lift disc check valves

Service pressure	< 2"	2 ½" - 12"	12" - 24"			
CHW < 200	2401	2411	2422			
HW < 125	2401	2411	2422			

N. Safety valves

Service pressure	Shut Off	Relief				
LPS < 15	2701	2711				
MPS 16-125	2701	2711				
HPS 126-300	2701	2711				

O. Automatic flow control valves

Service pressure	< 2" thread	2 ½" - 3"	3" - 14"	16" - 24"		
CHW <	na	na	2821	2831		

200						
HW < 200	na	na	2821	2831		

P. Solenoid valves

Service pressure	< 2" thread					
CHW < 125	2901 2902					
HW < 125	2901 2902					
MU	2901 2902					

END OF SECTION

SECTION 23 05 29

HANGERS AND SUPPORTS FOR HVAC PIPING AND EQUIPMENT

PART 1 - GENERAL

1.1 RELATED DOCUMENTS

- A. Drawings and general provisions of the Contract, including General and Supplementary Conditions and Division 1 Specification Sections, apply to this Section.
- B. Section 01 81 13 "Sustainable Design Requirements – LEED v4 for Building Design & Construction – New Construction" for sustainable design requirements and detailed sustainable design submittal requirements.
- C. Section 01 74 19 "Construction and Demolition Waste Management and Disposal" for disposal of construction, demolition and packaging waste disposal requirements.

1.2 SUMMARY

- A. This Section includes the following hangers and supports for HVAC system piping and equipment:
 - 1. Steel pipe hangers and supports.
 - 2. Trapeze pipe hangers.
 - 3. Metal framing systems.
 - 4. Thermal-hanger shield inserts.
 - 5. Fastener systems.
 - 6. Equipment supports.
- B. Related Sections include the following:
 - 1. Division 23 Section " Expansion Fittings and Loops for HVAC Piping" for pipe guides and anchors.
 - 2. Division 23 Section " Vibration and Seismic Controls for HVAC Piping and Equipment" for vibration isolation devices.
 - 3. Division 23 Section(s) "Metal Ducts" for duct hangers and supports.
- C. Sustainable Building Requirements:
 - 1. The Owner requires the Contractor to implement practices and procedures to meet the project's environmental performance goals, which include achieving LEED version 4 **Certified** level Certification. Specific project goals that may impact this area of work include: use of recycled-content materials; use of locally-manufactured materials; use of low-emitting materials; construction waste recycling; and the implementation of a construction indoor air quality management plan. The Contractor shall ensure that the requirements related to these goals, as defined in the Articles below, are implemented to the fullest extent. Substitutions, or other changes to the work proposed by the Contractor or their Subcontractors, shall not be allowed if such changes compromise the aforementioned environmental goals and LEED certification.

1.3 DEFINITIONS

- A. MSS: Manufacturers Standardization Society for The Valve and Fittings Industry Inc.
- B. Terminology: As defined in MSS SP-90, "Guidelines on Terminology for Pipe Hangers and Supports."

1.4 PERFORMANCE REQUIREMENTS

- A. Design supports for multiple pipes, including pipe stands, capable of supporting combined weight of supported systems, system contents, and test water.
- B. Design equipment supports capable of supporting combined operating weight of supported equipment and connected systems and components.
- C. Design seismic-restraint hangers and supports for piping and equipment.

1.5 SUPPLEMENTARY STEEL

- A. Furnish supplementary steel as required for proper installation, mounting and support of HVAC work.
- B. Connect supplementary steel firmly to building construction in an acceptable manner.
- C. Determine type and size of supplementary steel. Supplementary steel shall be of sufficient strength and size to allow a minimum deflection of 1/360 of the span and in conformance with manufacturer's requirements of loading.
- D. Install supplementary steel in a neat and workmanlike manner parallel to walls, floors and ceiling construction.
- E. All supplementary steel and channel supports shall be submitted to the structural engineer for review

1.6 EXPANSION ANCHORS

- A. Provide smooth wall, non-self-drilling internal plug expansion type anchors constructed of AISC 12L14 steel and zinc plated in accordance with Fed. Spec. QQ-A-325 Type 1, Class 3.
- B. Do not exceed 1/4 of average values for a specific anchor size using 2,000 psig (13,800 kpa) concrete only for maximum working load.
- C. Provide spacing and install anchors in accordance with manufacturer's recommendations.

1.7 SUBMITTALS

- A. Product Data: For the following:
 - 1. Steel pipe hangers and supports.
 - 2. Thermal-hanger shield inserts.
 - 3. Powder-actuated fastener systems.
- B. Shop Drawings: Show fabrication and installation details and include calculations for the following:
 - 1. Trapeze pipe hangers. Include Product Data for components.

2. Metal framing systems. Include Product Data for components.
3. Equipment supports.
- C. Submit to the structural engineer:
 1. Details of all proposed methods of attachment to the building structure for all hangers and supports.
 2. All forces and weights that will be imposed on the building structure by the hangers and supports.
- D. Welding certificates.

1.8 QUALITY ASSURANCE

- A. Welding: Qualify procedures and personnel according to AWS D1.1, "Structural Welding Code--Steel."
- B. Welding: Qualify procedures and personnel according to the following:
 1. AWS D1.1, "Structural Welding Code--Steel."
- C. Engineering Responsibility: Design and preparation of Shop Drawings and calculations for each multiple pipe support, trapeze, and seismic restraint by a qualified professional engineer.
 1. Professional Engineer Qualifications: A professional engineer who is legally qualified to practice in jurisdiction where Project is located and who is experienced in providing engineering services of the kind indicated. Engineering services are defined as those performed for installations of hangers and supports that are similar to those indicated for this Project in material, design, and extent

PART 2 - PRODUCTS

2.1 MANUFACTURERS

- A. In other Part 2 articles where titles below introduce lists, the following requirements apply to product selection:
 1. Manufacturers: Subject to compliance with requirements, provide products by one of the manufacturers specified.

2.2 STEEL PIPE HANGERS AND SUPPORTS

- A. Description: MSS SP-58, Types 1 through 58, factory-fabricated components. Refer to Part 3 "Hanger and Support Applications" Article for where to use specific hanger and support types.
- B. Manufacturers:
 1. AAA Technology & Specialties Co., Inc.
 2. B-Line Systems, Inc.; a division of Cooper Industries.
 3. Carpenter & Paterson, Inc.
 4. Empire Industries, Inc.
 5. Globe Pipe Hanger Products, Inc.
 6. Grinnell Corp.
 7. GS Metals Corp.
 8. National Pipe Hanger Corporation.

9. PHD Manufacturing, Inc.
10. Piping Technology & Products, Inc.
11. Tolco Inc.

- C. Galvanized, Metallic Coatings: Pregalvanized or hot dipped.
- D. Nonmetallic Coatings: Plastic coating, jacket, or liner.
- E. Padded Hangers: Hanger with fiberglass or other pipe insulation pad or cushion for support of bearing surface of piping.

2.3 TRAPEZE PIPE HANGERS

- A. Description: MSS SP-69, Type 59, shop- or field-fabricated pipe-support assembly made from structural-steel shapes with MSS SP-58 hanger rods, nuts, saddles, and U-bolts.

2.4 METAL FRAMING SYSTEMS

- A. Description: MFMA-3, shop- or field-fabricated pipe-support assembly made of steel channels and other components.
- B. Manufacturers:
 1. B-Line Systems, Inc.; a division of Cooper Industries.
 2. ERICO/Michigan Hanger Co.; ERISTRUT Div.
 3. GS Metals Corp.
 4. Power-Strut Div.; Tyco International, Ltd.
 5. Thomas & Betts Corporation.
 6. Tolco Inc.
 7. Unistrut Corp.; Tyco International, Ltd.
- C. Coatings: Manufacturer's standard finish, unless bare metal surfaces are indicated.
- D. Nonmetallic Coatings: Plastic coating, jacket, or liner.

2.5 THERMAL-HANGER SHIELD INSERTS

- A. Description: 100-psig- (690-kPa-) minimum, compressive-strength insulation insert encased in sheet metal shield.
- B. Manufacturers:
 1. Carpenter & Paterson, Inc.
 2. ERICO/Michigan Hanger Co.
 3. PHS Industries, Inc.
 4. Pipe Shields, Inc.
 5. Rilco Manufacturing Company, Inc.
 6. Value Engineered Products, Inc.
- C. Insulation-Insert Material for Cold Piping: ASTM C 552, Type II cellular glass with vapor barrier.
- D. Insulation-Insert Material for Hot Piping: ASTM C 552, Type II cellular glass.
- E. For Trapeze or Clamped Systems: Insert and shield shall cover entire circumference of pipe.
- F. For Clevis or Band Hangers: Insert and shield shall cover lower 180 degrees of pipe.

- G. Insert Length: Extend 2 inches (50 mm) beyond sheet metal shield for piping operating below ambient air temperature.

2.6 FASTENER SYSTEMS

- A. Powder-Actuated Fasteners: Threaded-steel stud, for use in hardened portland cement concrete with pull-out, tension, and shear capacities appropriate for supported loads and building materials where used.
 - 1. Manufacturers:
 - a. Hilti, Inc.
 - b. ITW Ramset/Red Head.
 - c. Masterset Fastening Systems, Inc.
 - d. MKT Fastening, LLC.
 - e. Powers Fasteners.
- B. Mechanical-Expansion Anchors: Insert-wedge-type zinc-coated steel, for use in hardened portland cement concrete with pull-out, tension, and shear capacities appropriate for supported loads and building materials where used.
 - 1. Manufacturers:
 - a. B-Line Systems, Inc.; a division of Cooper Industries.
 - b. Empire Industries, Inc.
 - c. Hilti, Inc.
 - d. ITW Ramset/Red Head.
 - e. MKT Fastening, LLC.
 - f. Powers Fasteners.

2.7 EQUIPMENT SUPPORTS

- A. Description: Welded, shop- or field-fabricated equipment support made from structural-steel shapes.

2.8 MISCELLANEOUS MATERIALS

- A. Structural Steel: ASTM A 36/A 36M, steel plates, shapes, and bars; black and galvanized.
- B. Grout: ASTM C 1107, factory-mixed and -packaged, dry, hydraulic-cement, nonshrink and nonmetallic grout; suitable for interior and exterior applications.
 - 1. Properties: Nonstaining, noncorrosive, and nongaseous.
 - 2. Design Mix: 5000-psi (34.5-MPa), 28-day compressive strength.

PART 3 - EXECUTION

3.1 HANGER AND SUPPORT APPLICATIONS

- A. Specific hanger and support requirements are specified in Sections specifying piping systems and equipment.
- B. Comply with MSS SP-69 for pipe hanger selections and applications that are not specified in piping system Sections.
- C. Use hangers and supports with galvanized, metallic coatings for piping and equipment that will not have field-applied finish.

- D. Use nonmetallic coatings on attachments for electrolytic protection where attachments are in direct contact with copper tubing.
- E. Use padded hangers for piping that is subject to scratching.
- F. Horizontal-Piping Hangers and Supports: Unless otherwise indicated and except as specified in piping system Sections, install the following types:
 - 1. Adjustable, Steel Clevis Hangers (MSS Type 1): For suspension of noninsulated or insulated stationary pipes, NPS 1/2 to NPS 30 (DN 15 to DN 750).
 - 2. Yoke-Type Pipe Clamps (MSS Type 2): For suspension of 120 to 450 deg F (49 to 232 deg C) pipes, NPS 4 to NPS 16 (DN 100 to DN 400), requiring up to 4 inches (100 mm) of insulation.
 - 3. Carbon- or Alloy-Steel, Double-Bolt Pipe Clamps (MSS Type 3): For suspension of pipes, NPS 3/4 to NPS 24 (DN 20 to DN 600), requiring clamp flexibility and up to 4 inches (100 mm) of insulation.
 - 4. Steel Pipe Clamps (MSS Type 4): For suspension of cold and hot pipes, NPS 1/2 to NPS 24 (DN 15 to DN 600), if little or no insulation is required.
 - 5. Pipe Hangers (MSS Type 5): For suspension of pipes, NPS 1/2 to NPS 4 (DN 15 to DN 100), to allow off-center closure for hanger installation before pipe erection.
 - 6. Adjustable, Swivel Split- or Solid-Ring Hangers (MSS Type 6): For suspension of noninsulated stationary pipes, NPS 3/4 to NPS 8 (DN 20 to DN 200).
 - 7. Adjustable, Steel Band Hangers (MSS Type 7): For suspension of noninsulated stationary pipes, NPS 1/2 to NPS 8 (DN 15 to DN 200).
 - 8. Adjustable Band Hangers (MSS Type 9): For suspension of noninsulated stationary pipes, NPS 1/2 to NPS 8 (DN 15 to DN 200).
 - 9. Adjustable, Swivel-Ring Band Hangers (MSS Type 10): For suspension of noninsulated stationary pipes, NPS 1/2 to NPS 2 (DN 15 to DN 50).
 - 10. Split Pipe-Ring with or without Turnbuckle-Adjustment Hangers (MSS Type 11): For suspension of noninsulated stationary pipes, NPS 3/8 to NPS 8 (DN 10 to DN 200).
 - 11. Extension Hinged or 2-Bolt Split Pipe Clamps (MSS Type 12): For suspension of noninsulated stationary pipes, NPS 3/8 to NPS 3 (DN 10 to DN 80).
 - 12. U-Bolts (MSS Type 24): For support of heavy pipes, NPS 1/2 to NPS 30 (DN 15 to DN 750).
 - 13. Clips (MSS Type 26): For support of insulated pipes not subject to expansion or contraction.
 - 14. Pipe Saddle Supports (MSS Type 36): For support of pipes, NPS 4 to NPS 36 (DN 100 to DN 900), with steel pipe base stanchion support and cast-iron floor flange.
 - 15. Pipe Stanchion Saddles (MSS Type 37): For support of pipes, NPS 4 to NPS 36 (DN 100 to DN 900), with steel pipe base stanchion support and cast-iron floor flange and with U-bolt to retain pipe.
 - 16. Adjustable, Pipe Saddle Supports (MSS Type 38): For stanchion-type support for pipes, NPS 2-1/2 to NPS 36 (DN 65 to DN 900), if vertical adjustment is required, with steel pipe base stanchion support and cast-iron floor flange.
 - 17. Single Pipe Rolls (MSS Type 41): For suspension of pipes, NPS 1 to NPS 30 (DN 25 to DN 750), from 2 rods if longitudinal movement caused by expansion and contraction might occur.
 - 18. Adjustable Roller Hangers (MSS Type 43): For suspension of pipes, NPS 2-1/2 to NPS 20 (DN 65 to DN 500), from single rod if horizontal movement caused by expansion and contraction might occur.

19. Complete Pipe Rolls (MSS Type 44): For support of pipes, NPS 2 to NPS 42 (DN 50 to DN 1050), if longitudinal movement caused by expansion and contraction might occur but vertical adjustment is not necessary.
 20. Pipe Roll and Plate Units (MSS Type 45): For support of pipes, NPS 2 to NPS 24 (DN 50 to DN 600), if small horizontal movement caused by expansion and contraction might occur and vertical adjustment is not necessary.
 21. Adjustable Pipe Roll and Base Units (MSS Type 46): For support of pipes, NPS 2 to NPS 30 (DN 50 to DN 750), if vertical and lateral adjustment during installation might be required in addition to expansion and contraction.
- G. Vertical-Piping Clamps: Unless otherwise indicated and except as specified in piping system Sections, install the following types:
1. Extension Pipe or Riser Clamps (MSS Type 8): For support of pipe risers, NPS 3/4 to NPS 20 (DN 20 to DN 500).
 2. Carbon- or Alloy-Steel Riser Clamps (MSS Type 42): For support of pipe risers, NPS 3/4 to NPS 20 (DN 20 to DN 500), if longer ends are required for riser clamps.
- H. Hanger-Rod Attachments: Unless otherwise indicated and except as specified in piping system Sections, install the following types:
1. Steel Turnbuckles (MSS Type 13): For adjustment up to 6 inches (150 mm) for heavy loads.
 2. Steel Clevises (MSS Type 14): For 120 to 450 deg F (49 to 232 deg C) piping installations.
 3. Swivel Turnbuckles (MSS Type 15): For use with MSS Type 11, split pipe rings.
 4. Malleable-Iron Sockets (MSS Type 16): For attaching hanger rods to various types of building attachments.
 5. Steel Weldless Eye Nuts (MSS Type 17): For 120 to 450 deg F (49 to 232 deg C) piping installations.
- I. Building Attachments: Unless otherwise indicated and except as specified in piping system Sections, install the following types:
1. Steel or Malleable Concrete Inserts (MSS Type 18): For upper attachment to suspend pipe hangers from concrete ceiling.
 2. Top-Beam C-Clamps (MSS Type 19): For use under roof installations with bar-joist construction to attach to top flange of structural shape.
 3. Side-Beam or Channel Clamps (MSS Type 20): For attaching to bottom flange of beams, channels, or angles.
 4. Center-Beam Clamps (MSS Type 21): For attaching to center of bottom flange of beams.
 5. Welded Beam Attachments (MSS Type 22): For attaching to bottom of beams if loads are considerable and rod sizes are large.
 6. C-Clamps (MSS Type 23): For structural shapes.
 7. Top-Beam Clamps (MSS Type 25): For top of beams if hanger rod is required tangent to flange edge.
 8. Side-Beam Clamps (MSS Type 27): For bottom of steel I-beams.
 9. Steel-Beam Clamps with Eye Nuts (MSS Type 28): For attaching to bottom of steel I-beams for heavy loads.
 10. Linked-Steel Clamps with Eye Nuts (MSS Type 29): For attaching to bottom of steel I-beams for heavy loads, with link extensions.
 11. Malleable Beam Clamps with Extension Pieces (MSS Type 30): For attaching to structural steel.

12. Welded-Steel Brackets: For support of pipes from below, or for suspending from above by using clip and rod. Use one of the following for indicated loads:
 - a. Light (MSS Type 31): 750 lb (340 kg).
 - b. Medium (MSS Type 32): 1500 lb (680 kg).
 - c. Heavy (MSS Type 33): 3000 lb (1360 kg).
 13. Side-Beam Brackets (MSS Type 34): For sides of steel or wooden beams.
 14. Plate Lugs (MSS Type 57): For attaching to steel beams if flexibility at beam is required.
 15. Horizontal Travelers (MSS Type 58): For supporting piping systems subject to linear horizontal movement where headroom is limited.
- J. Saddles and Shields: Unless otherwise indicated and except as specified in piping system Sections, install the following types:
1. Steel Pipe-Covering Protection Saddles (MSS Type 39): To fill interior voids with insulation that matches adjoining insulation.
 2. Protection Shields (MSS Type 40): Of length recommended in writing by manufacturer to prevent crushing insulation.
 3. Thermal-Hanger Shield Inserts: For supporting insulated pipe.
- K. Spring Hangers and Supports: Unless otherwise indicated and except as specified in piping system Sections, install the following types:
1. Restraint-Control Devices (MSS Type 47): Where indicated to control piping movement.
 2. Spring Cushions (MSS Type 48): For light loads if vertical movement does not exceed 1-1/4 inches (32 mm).
 3. Spring-Cushion Roll Hangers (MSS Type 49): For equipping Type 41 roll hanger with springs.
 4. Spring Sway Braces (MSS Type 50): To retard sway, shock, vibration, or thermal expansion in piping systems.
 5. Variable-Spring Hangers (MSS Type 51): Preset to indicated load and limit variability factor to 25 percent to absorb expansion and contraction of piping system from hanger.
 6. Variable-Spring Base Supports (MSS Type 52): Preset to indicated load and limit variability factor to 25 percent to absorb expansion and contraction of piping system from base support.
 7. Variable-Spring Trapeze Hangers (MSS Type 53): Preset to indicated load and limit variability factor to 25 percent to absorb expansion and contraction of piping system from trapeze support.
 8. Constant Supports: For critical piping stress and if necessary to avoid transfer of stress from one support to another support, critical terminal, or connected equipment. Include auxiliary stops for erection, hydrostatic test, and load-adjustment capability. These supports include the following types:
 - a. Horizontal (MSS Type 54): Mounted horizontally.
 - b. Vertical (MSS Type 55): Mounted vertically.
 - c. Trapeze (MSS Type 56): Two vertical-type supports and one trapeze member.
- L. Comply with MSS SP-69 for trapeze pipe hanger selections and applications that are not specified in piping system Sections.
- M. Comply with MFMA-102 for metal framing system selections and applications that are not specified in piping system Sections.

- N. Use powder-actuated fasteners or mechanical-expansion anchors instead of building attachments where required in concrete construction.

3.2 HANGER AND SUPPORT INSTALLATION

- A. Steel Pipe Hanger Installation: Comply with MSS SP-69 and MSS SP-89. Install hangers, supports, clamps, and attachments as required to properly support piping from building structure.
- B. Trapeze Pipe Hanger Installation: Comply with MSS SP-69 and MSS SP-89. Arrange for grouping of parallel runs of horizontal piping and support together on field-fabricated trapeze pipe hangers.
 - 1. Pipes of Various Sizes: Support together and space trapezes for smallest pipe size or install intermediate supports for smaller diameter pipes as specified above for individual pipe hangers.
 - 2. Field fabricate from ASTM A 36/A 36M, steel shapes selected for loads being supported. Weld steel according to AWS D1.1.
- C. Metal Framing System Installation: Arrange for grouping of parallel runs of piping and support together on field-assembled metal framing systems.
- D. Thermal-Hanger Shield Installation: Install in pipe hanger or shield for insulated piping.
- E. Fastener System Installation:
 - 1. Install powder-actuated fasteners for use in lightweight concrete or concrete slabs less than 4 inches (100 mm) thick in concrete after concrete is placed and completely cured. Use operators that are licensed by powder-actuated tool manufacturer. Install fasteners according to powder-actuated tool manufacturer's operating manual.
 - 2. Install mechanical-expansion anchors in concrete after concrete is placed and completely cured. Install fasteners according to manufacturer's written instructions.
- F. Install hangers and supports complete with necessary inserts, bolts, rods, nuts, washers, and other accessories.
- G. Equipment Support Installation: Fabricate from welded-structural-steel shapes.
- H. Install hangers and supports to allow controlled thermal and seismic movement of piping systems, to permit freedom of movement between pipe anchors, and to facilitate action of expansion joints, expansion loops, expansion bends, and similar units.
- I. Install lateral bracing with pipe hangers and supports to prevent swaying.
- J. Install building attachments within concrete slabs or attach to structural steel. Install additional attachments at concentrated loads, including valves, flanges, and strainers, NPS 2-1/2 (DN 65) and larger and at changes in direction of piping. Install concrete inserts before concrete is placed; fasten inserts to forms and install reinforcing bars through openings at top of inserts.
- K. Load Distribution: Install hangers and supports so piping live and dead loads and stresses from movement will not be transmitted to connected equipment.
- L. Pipe Slopes: Install hangers and supports to provide indicated pipe slopes and so maximum pipe deflections allowed by ASME B31.1 (for power piping) and ASME B31.9 (for building services piping) are not exceeded.

- M. Insulated Piping: Comply with the following:
1. Attach clamps and spacers to piping.
 - a. Piping Operating above Ambient Air Temperature: Clamp may project through insulation.
 - b. Piping Operating below Ambient Air Temperature: Use thermal-hanger shield insert with clamp sized to match OD of insert.
 - c. Do not exceed pipe stress limits according to ASME B31.1 for power piping and ASME B31.9 for building services piping.
 2. Install MSS SP-58, Type 39, protection saddles if insulation without vapor barrier is indicated. Fill interior voids with insulation that matches adjoining insulation.
 - a. Option: Thermal-hanger shield inserts may be used. Include steel weight-distribution plate for pipe NPS 4 (DN 100) and larger if pipe is installed on rollers.
 3. Install MSS SP-58, Type 40, protective shields on cold piping with vapor barrier. Shields shall span an arc of 180 degrees.
 - a. Option: Thermal-hanger shield inserts may be used. Include steel weight-distribution plate for pipe NPS 4 (DN 100) and larger if pipe is installed on rollers.
 4. Shield Dimensions for Pipe: Not less than the following:
 - a. NPS 1/4 to NPS 3-1/2 (DN 8 to DN 90): 12 inches (305 mm) long and 0.048 inch (1.22 mm) thick.
 - b. NPS 4 (DN 100): 12 inches (305 mm) long and 0.06 inch (1.52 mm) thick.
 - c. NPS 5 and NPS 6 (DN 125 and DN 150): 18 inches (457 mm) long and 0.06 inch (1.52 mm) thick.
 - d. NPS 8 to NPS 14 (DN 200 to DN 350): 24 inches (610 mm) long and 0.075 inch (1.91 mm) thick.
 - e. NPS 16 to NPS 24 (DN 400 to DN 600): 24 inches (610 mm) long and 0.105 inch (2.67 mm) thick.
 5. Pipes NPS 8 (DN 200) and Larger: Include wood inserts.
 6. Insert Material: Length at least as long as protective shield.
 7. Thermal-Hanger Shields: Install with insulation same thickness as piping insulation.

3.3 EQUIPMENT SUPPORTS

- A. Fabricate structural-steel stands to suspend equipment from structure overhead or to support equipment above floor.
- B. Grouting: Place grout under supports for equipment and make smooth bearing surface.
- C. Provide lateral bracing, to prevent swaying, for equipment supports.

3.4 METAL FABRICATIONS

- A. Cut, drill, and fit miscellaneous metal fabrications for trapeze pipe hangers and equipment supports.
- B. Fit exposed connections together to form hairline joints. Field weld connections that cannot be shop welded because of shipping size limitations.

- C. Field Welding: Comply with AWS D1.1 procedures for shielded metal arc welding, appearance and quality of welds, and methods used in correcting welding work, and with the following:
 - 1. Use materials and methods that minimize distortion and develop strength and corrosion resistance of base metals.
 - 2. Obtain fusion without undercut or overlap.
 - 3. Remove welding flux immediately.
 - 4. Finish welds at exposed connections so no roughness shows after finishing and contours of welded surfaces match adjacent contours.

3.5 ADJUSTING

- A. Hanger Adjustments: Adjust hangers to distribute loads equally on attachments and to achieve indicated slope of pipe.
- B. Trim excess length of continuous-thread hanger and support rods to 1-1/2 inches (40 mm).

3.6 PAINTING

- A. Touch Up: Cleaning and touchup painting of field welds, bolted connections, and abraded areas of shop paint on miscellaneous metal are specified in Division 09 painting Sections.
- B. Galvanized Surfaces: Clean welds, bolted connections, and abraded areas and apply galvanizing-repair paint to comply with ASTM A 780.

END OF SECTION

This page is intentionally left blank.

SECTION 23 05 33

HEAT TRACING FOR HVAC PIPING

PART 1 - GENERAL

1.1 RELATED DOCUMENTS

- A. Drawings and general provisions of the Contract, including General and Supplementary Conditions and Division 01 Specification Sections, apply to this Section.
- B. Section 01 81 13 "Sustainable Design Requirements – LEED v4 for Building Design & Construction – New Construction" for sustainable design requirements and detailed sustainable design submittal requirements.
- C. Section 01 74 19 "Construction and Demolition Waste Management and Disposal" for disposal of construction, demolition and packaging waste disposal requirements.

1.2 SUMMARY

- A. This Section includes heat tracing with the following electric heating cables:
 - 1. Plastic insulated, series resistance.
 - 2. Self-regulating, parallel resistance.
- B. Sustainable Building Requirements:
 - 1. The Owner requires the Contractor to implement practices and procedures to meet the project's environmental performance goals, which include achieving LEED version 4 **Certified** level Certification. Specific project goals that may impact this area of work include: use of recycled-content materials; use of locally-manufactured materials; use of low-emitting materials; construction waste recycling; and the implementation of a construction indoor air quality management plan. The Contractor shall ensure that the requirements related to these goals, as defined in the Articles below, are implemented to the fullest extent. Substitutions, or other changes to the work proposed by the Contractor or their Subcontractors, shall not be allowed if such changes compromise the aforementioned environmental goals and LEED certification.

1.3 SUBMITTALS

- A. Product Data: Include rated capacities, operating characteristics, furnished specialties, and accessories for each type of product indicated.
 - 1. Schedule heating capacity, length of cable, spacing, and electrical power requirement for each electric heating cable required.
- B. Shop Drawings: For electric heating cable. Include plans, sections, details, and attachments to other work.
 - 1. Wiring Diagrams: Power, signal, and control wiring.
- C. Field quality-control test reports.

- D. Operation and Maintenance Data: For electric heating cables to include in operation and maintenance manuals.
- E. Warranty: Special warranty specified in this Section.

1.4 QUALITY ASSURANCE

- A. Electrical Components, Devices, and Accessories: Listed and labeled as defined in NFPA 70, Article 100, by a testing agency acceptable to authorities having jurisdiction, and marked for intended use.

1.5 WARRANTY

- A. Special Warranty: Manufacturer's standard form in which manufacturer agrees to repair or replace electric heating cable that fails in materials or workmanship within specified warranty period.
 - 1. Warranty Period: 15 years from date of Substantial Completion.

PART 2 - PRODUCTS

2.1 SELF-REGULATING, PARALLEL-RESISTANCE HEATING CABLES

- A. Available Manufacturers: Subject to compliance with requirements, manufacturers offering products that may be incorporated into the Work include, but are not limited to, the following:
- B. Manufacturers: Subject to compliance with requirements, provide products by one of the following:
 - 1. Chromalox, Inc.; Wiegard Industrial Division; Emerson Electric Company.
 - 2. Raychem; a division of Tyco Thermal Controls.
 - 3. Thermon Manufacturing Co.
- C. Heating Element: Pair of parallel No. 16 AWG, nickel-coated stranded copper bus wires embedded in crosslinked conductive polymer core, which varies heat output in response to temperature along its length. Terminate with waterproof, factory-assembled nonheating leads with connectors at one end, and seal the opposite end watertight. Cable shall be capable of crossing over itself once without overheating.
- D. Electrical Insulating Jacket: Flame-retardant polyolefin.
- E. Cable Cover: Tinned-copper braid, and polyolefin outer jacket with UV inhibitor.
- F. Maximum Operating Temperature (Power On): 150 deg F (65 deg C).
- G. Maximum Exposure Temperature (Power Off): 150 deg F (65 deg C).
- H. Maximum Operating Temperature: 300 deg F (150 deg C).
- I. Capacities and Characteristics:
 - 1. Maximum Heat Output: 5 W/ft. (16.4 W/m).
 - 2. Piping Diameter: SEE PLANS.
 - 3. Number of Parallel Cables: 2.
 - 4. Volts: 120 V.
 - 5. Phase: 1.
 - 6. Hertz: 60.

2.2 CONTROLS

- A. Remote bulb unit with adjustable temperature range from 30 to 50 deg F (minus 1 to plus 10 deg C).
- B. Snap action; open-on-rise, single-pole switch with minimum current rating adequate for connected cable.
- C. Remote bulb on capillary, resistance temperature device, or thermistor for directly sensing pipe-wall temperature.
- D. Corrosion-resistant, waterproof control enclosure.

2.3 ACCESSORIES

- A. Cable Installation Accessories: Fiberglass tape, heat-conductive putty, cable ties, silicone end seals and splice kits, and installation clips all furnished by manufacturer, or as recommended in writing by manufacturer.
- B. Warning Labels: Refer to Division 23 Section "Identification for HVAC Piping and Equipment."
- C. Warning Tape: Continuously printed "Electrical Tracing"; vinyl, at least 3 mils (0.08 mm) thick, and with pressure-sensitive, permanent, waterproof, self-adhesive back.
 - 1. Width for Markers on Pipes with OD, Including Insulation, Less Than 6 Inches (150 mm): 3/4 inch (19 mm) minimum.
 - 2. Width for Markers on Pipes with OD, Including Insulation, 6 Inches (150 mm) or Larger: 1-1/2 inches (38 mm) minimum.

PART 3 - EXECUTION

3.1 EXAMINATION

- A. Examine surfaces and substrates to receive electric heating cables for compliance with requirements for installation tolerances and other conditions affecting performance.
 - 1. Ensure surfaces and pipes in contact with electric heating cables are free of burrs and sharp protrusions.
 - 2. Proceed with installation only after unsatisfactory conditions have been corrected.

3.2 INSTALLATION

- A. Install electric heating cable across expansion joints according to manufacturer's written recommendations using slack cable to allow movement without damage to cable.
- B. Install electric heating cables after piping has been tested and before insulation is installed.
- C. Install electric heating cables according to IEEE 515.1.
- D. Install insulation over piping with electric cables according to Division 23 Section "HVAC Insulation."

- E. Install warning tape on piping insulation where piping is equipped with electric heating cables.
- F. Set field-adjustable switches and circuit-breaker trip ranges.
- G. Protect installed heating cables, including nonheating leads, from damage.

3.3 CONNECTIONS

- A. Ground equipment according to Division 26 Section "Grounding and Bonding for Electrical Systems."
- B. Connect wiring according to Division 26 Section "Low-Voltage Electrical Power Conductors and Cables."

3.4 FIELD QUALITY CONTROL

- A. Testing: Perform tests after cable installation but before application of coverings such as insulation, wall or ceiling construction, or concrete.
 - 1. Test cables for electrical continuity and insulation integrity before energizing.
 - 2. Test cables to verify rating and power input. Energize and measure voltage and current simultaneously.
- B. Repeat tests for continuity, insulation resistance, and input power after applying thermal insulation on pipe-mounting cables.
- C. Remove and replace malfunctioning units and retest as specified above.

END OF SECTION

SECTION 23 05 48

MECHANICAL VIBRATION ISOLATION AND SEISMIC RESTRAINT SYSTEMS

PART 1 - GENERAL

1.1 RELATED DOCUMENTS

- A. Drawings and general provisions of the Contract, including General and Supplementary Conditions and Division 1 Specification Sections, apply to this Section.
- B. Section 01 81 13 "Sustainable Design Requirements – LEED v4 for Building Design & Construction – New Construction" for sustainable design requirements and detailed sustainable design submittal requirements.
- C. Section 01 74 19 "Construction and Demolition Waste Management and Disposal" for disposal of construction, demolition and packaging waste disposal requirements.

1.2 SUMMARY

- A. It is the objective of this Specification to provide the necessary design requirements for the control of excessive noise and vibration in the buildings due to the operation of machinery or equipment, and/or due to interconnected piping, ductwork or conduit. It is also the objective of this specification to provide the design criteria for seismic restraints for all isolated and non-isolated equipment.
- B. Work in this section includes the providing of labor, materials, equipment and services necessary for a complete and safe installation in of vibration isolation systems and seismic restraints for every mechanical system including piping and ductwork within and on the roof of the building, complete, as shown and specified per the contract documents and all applicable codes and authorities having jurisdiction.
- C. The work of this section includes, but is not limited to the following:
 - 1. Vibration isolation elements for piping and equipment.
 - 2. Equipment isolation bases.
 - 3. Piping flexible connections.
 - 4. Seismic restraints for isolated and non-isolated piping, tanks, stacks, ductwork, VAV boxes, and equipment.
- D. Related Sections:
 - 1. All Division 23000 Sections as issued for this project.
- E. Seismic restraints:
 - 1. All equipment, piping and ductwork shall be adequately restrained to resist seismic forces. This specification is in addition to the specified vibration isolation for this project. Restraint devices shall be designed and selected to meet seismic requirements as defined in the latest issue of the state and local codes and other authorities having jurisdiction.
 - 2. Anchor bolt calculations, signed and stamped by a registered Professional Engineer, shall be submitted showing adequacy of the bolt sizing and type. Calculations shall include anchor embedment, minimum edge distance and minimum center distance. The design lateral forces shall be distributed in proportion to the mass distribution of the equipment. Calculations shall be

- furnished for anchors on restraint devices, cables, isolators and on rigid mounted equipment. The seismic designer must perform final jobsite inspection to verify anchor installation.
3. Contractor shall supply all supplemental steel required for all equipment, ductwork and piping including roof mounted equipment.
 4. All isolators and equipment shall meet OSHPD requirements and contain approval from OSHPD.
- F. This specification shall be supplemented by all local codes and ordinance which shall take precedence in the event of the existence of any conflict between same and this specification. Where methods or materials specified are equivalent to the code requirements specified, comply with the specified requirements.
- G. Seismic-Restraint Loading:
1. Site Class as Defined in the IBC: D
 2. Assigned Seismic Use Group or Building Design Category as Defined in the IBC: C
 - a. Component Importance Factor: 1.50
 - b. Component Response Modification Factor: 6.0
 - c. Component Amplification Factor: 2.5
 3. Design Spectral Response Acceleration at Short Periods (0.123 Second): 0.327
 4. Design Spectral Response Acceleration at 1-Second Period: 0.077
- H. Sustainable Building Requirements:
1. The Owner requires the Contractor to implement practices and procedures to meet the project's environmental performance goals, which include achieving LEED version 4 **Certified** level Certification. Specific project goals that may impact this area of work include: use of recycled-content materials; use of locally-manufactured materials; use of low-emitting materials; construction waste recycling; and the implementation of a construction indoor air quality management plan. The Contractor shall ensure that the requirements related to these goals, as defined in the Articles below, are implemented to the fullest extent. Substitutions, or other changes to the work proposed by the Contractor or their Subcontractors, shall not be allowed if such changes compromise the aforementioned environmental goals and LEED certification.

1.3 SUBMITTALS

- A. In addition to the requirements of the section on Mechanical General Provisions, the submittal material shall include descriptive data for all products and materials including, but not limited to, the following:
1. Descriptive Data:
 - a. Catalog cuts and data sheets on specific vibration isolators and seismic restraints to be utilized showing compliance with the specifications.
 - b. An itemized list showing the items of equipment or piping to be isolated, the isolator type and model number selected, isolator loading and deflection, and reference to specific drawings showing seismic restraints, base and construction where applicable.
 - c. An itemized list of non-isolated equipment, piping, and ductwork to be seismically restrained.
 - d. Seismic restraint calculations.
 - e. Riser supports: Include riser diagrams and calculations showing anticipated expansion and contraction at each support point, initial and final loads on building structure, spring deflection changes and seismic loads. Include certification that riser system has been examined for excessive stress and that none will exist.

- f. Structural or civil engineer's stamp verifying design and calculations for seismic restraining systems used.
2. Shop Drawings:
 - a. Drawings showing equipment base constructions for each machine, including dimensions, structural member sizes and support point locations.
 - b. Drawings showing methods of suspension, support guides for piping and ductwork.
 - c. Drawings showing methods for isolation of pipes and ductwork piercing walls and slabs.
 - d. Concrete and steel details for bases, including anchor bolt locations.
 - e. Number and location of seismic restraints and anchors for each piece of equipment and of ductwork and piping.
 - f. Specific details of restraints, including anchor bolts for mounting and maximum loading at each location for each piece of equipment and lengths of ductwork and piping.

1.4 CODE AND REFERENCE STANDARD REQUIREMENTS

- A. All equipment supplied under this specification shall conform in all respects to the rules and regulations of:
 1. SMACNA "Guidelines for Seismic Restraints of Mechanical Systems and Plumbing Piping Systems." 1982
 2. 2003 ASHRAE GUIDE, Chapter 47, and Chapter 54
 3. All applicable state and local codes and authorities having jurisdiction.
 4. American Society for Testing and Materials:
 - a. ASTM A 36/a 36M-96: Specification for Carbon Structural Steel.
 - b. ASTM E 488-96: Test Methods for Strength of Anchors in Concrete and Masonry Elements.
 5. American Welding Society:
 - a. ASW D1.1-98: Structural Welding Code – Steel.

1.5 QUALITY ASSURANCE

- A. All vibration isolation and seismic restraint devices shall be the product of a single manufacturer. Products of other manufacturer's are acceptable provided that their systems comply with the design intent for system performance, static deflection and structural design of the base manufacturer.
- B. Vibration isolation firms having a minimum ten years experience designing and supervising the installation of vibration isolation and seismic restraint systems shall be qualified to provide the materials and installation required by this section. Project listings shall be provided including geographical location and a reference contact.
- C. The installation of all vibration isolation units, and associated seismic restraints, hangers and bases, shall be under the direct supervision of the vibration isolation manufacturer's representative. The isolation manufacturer is to send a letter stating that they have inspected all of the vibration isolation units installed and they are installed properly and operating.
- D. Substitution of internally isolated mechanical equipment in lieu of the specified isolation of this Section must be approved for individual equipment units and is acceptable only if above acceleration loads are certified in writing by the equipment manufacturer and stamped and sealed by a licensed civil or structural engineer.

- E. Purchased and/or fabricated equipment must be designed to safely accept external forces of 1.0 g load in any direction for all rigidly and resiliently supported equipment, piping and ductwork without failure and permanent displacement of the equipment. Life safety equipment such as fire pumps, smoke exhaust fans, emergency generators and other life safety designated equipment must be capable of accepting external forces of up to 1.5 g in any direction without permanent displacement or failure of the equipment.
- F. Standards: If any item in this specification as furnished by the contractor is manufactured in a location which does not certify the referenced standards as defined in paragraph 1.4 of this specification, the contractor is to pay the owner for all expenses incurred by the owner for an outside testing company to confirm such compliances.
- G. Welding: Qualify procedures and personnel according to AWS D1.1, "Structural Welding Code--Steel."

1.6 DELIVERY, STORAGE, AND HANDLING

- A. Deliver each item as a factory-assembled unit with protective crating and covering.
- B. Store in a dry location.
- C. Provide disassembly and re-assembly as required to accommodate rigging and shipping.
- D. Comply with the manufacturer's written rigging and installation instructions for unloading, transporting and setting in final location.
- E. All equipment with shaft bearings (pump, fans, etc..) must have the shaft rotated every 2 weeks and the equipment must be stored inside.

1.7 SUBSTITUTIONS

- A. Any proposed substitution must be submitted at the time the bid is submitted. No substitute material or manufacturer of equipment shall be permitted without a formal written submittal to the engineer which includes all dimensional, performance and material specifications and is approved in writing by the engineer. Any changes in layout or design brought about by the use of a substitution shall be submitted to the engineer fully designed for review in conjunction with the submittal of the alternate. Any substitutions must be submitted with an explanation why a substitution is being proposed. If the substitute is being proposed for financial reasons the associated credit must be simultaneously submitted.
- B. Final acceptance or rejection of any substitution is subject to the Owner's review.

1.8 COORDINATION

- A. Coordinate size and location of concrete bases. Cast anchor-bolt inserts into base. Coordinate with the architect and structural engineer for concrete, reinforcement, and formwork requirements.
- B. Coordinate installation of roof curbs, equipment supports, and roof penetrations. These items are specified in Division 7 Section "Roof Accessories."

PART 2 - PRODUCTS

2.1 MANUFACTURERS

- A. The following are approved manufacturers, provided their systems strictly comply with the design intent for performance, deflection and structural capacity of this specification.
1. Mason Industries, Inc., Hauppauge, NY
 2. Vibration Mountings & Controls, Inc., Bloomingdale, NJ
 3. Kinetics Noise Control, Dublin, OH
 4. Vibration Eliminator Co., Inc., Capiague, NY
 5. Amber Booth, Houston, TX

2.2 DESCRIPTION

- A. All vibration isolators shall have either known undeflected heights or calibration markings so that, after adjustment, when carrying their load, the deflection under load can be verified, thus determining that the load is within the proper range of the device and that the correct degree of vibration isolation is being provided according to the design.
- B. All isolators shall operate in the linear portion of their load versus deflection curve. Load versus deflection curves shall be furnished by the manufacturer, and must be linear over a deflection range of not less than 50% above the design deflection.
- C. Where spring isolation systems are described in the following specifications, the mounting assemblies shall utilize bare springs with the spring diameter not less than 0.8 of the loaded operating height of the spring. Each spring isolator shall be designed and installed so that the ends of the springs remain parallel. The minimum deflection from loaded operating height to spring solid height shall be 50% of the rated static deflection of the spring.
- D. Where neoprene-in-shear isolation systems are described in the following specifications, the mounting assemblies shall utilize bare neoprene elements with unit type design molded in oil resistant neoprene. The neoprene shall be compounded to meet the following:
1. Shore hardness of 35 to 65 \pm 5, after minimum aging of 20 days or corresponding oven-aging.
 2. Minimum tensile strength of 2000 PSI.
 3. Minimum elongation of 300 %.
 4. Maximum compression at 25 % of original deflection.
- E. The isolator ratio of lateral to vertical stiffness shall not be less than 0.9 nor more than 1.5.
- F. The theoretical vertical natural frequency for each support point, based upon load per isolator and isolator stiffness, shall not differ from the design objectives for the equipment as a whole by more than \pm 10%.
- G. All mounting systems, including seismic restraints, exposed to weather and other corrosive environments shall be protected with factory corrosion resistance. All metal parts of mountings (except springs and hardware) to be hot dip galvanized. Springs shall be powder coated and neoprene coated. Nuts and bolts shall be cadmium plated.
- H. All roof-mounted isolators shall be bolted or welded to building steel and anchored to the structure to resist 110 mph wind loads.

2.3 MANUFACTURER RESPONSIBILITIES

- A. Manufacturer of vibration isolation and seismic restraint equipment shall have the following responsibilities:
 - 1. Determine vibration isolation and seismic restraint sizes and locations.
 - 2. Provide piping and equipment isolation systems and seismic restraints as scheduled or specified.
 - 3. Guarantee specified isolation system deflection.
 - 4. Provide installation instructions, drawings and field supervision to assure proper installation and performance.

2.4 VIBRATION ISOLATORS

- A. Type A: Bare spring isolators shall incorporate the following:
 - 1. Minimum 1/4" (6 mm) thick neoprene acoustical base pad on underside, unless designated otherwise.
 - 2. Non-resonant with equipment forcing frequencies or support structure natural frequencies.
 - 3. Requires seismic restraint type II
 - 4. Spring isolators to be Mason Type SLF, or as approved.
- B. Type B: Spring isolators shall be same as Type A, except:
 - 1. Provide built-in vertical limit stops with minimum 1/4" clearance under normal operation.
 - 2. Tapped holes in top plate for bolting to equipment. All hot dipped galvanized for outdoor installation such as at the air cooled chiller and centrifugal exhaust fans.
 - 3. Capable of supporting equipment at a fixed elevation during equipment erection. Installed and operating heights shall be identical.
 - 4. Shall incorporate snubbing restraint in all directions. Cast or aluminum housings are unacceptable. System to be field bolted or welded to deck with ability to resist forces of 1.5 g acceleration.
 - 5. Mason Type SLR, or as approved.
- C. Type C: Spring hanger rod isolators shall incorporate the following:
 - 1. Spring element seated on a steel washer within a neoprene cup incorporating a rod isolation bushing.
 - 2. Steel retainer box encasing the spring and neoprene cup.
 - 3. Provide sufficient clearance between retainer box and spring hanger rod to permit minimum 15 degree allowable rod misalignment in any direction, total 30 degrees.
 - 4. Requires seismic restraint type III
 - 5. Mason Type TPC-30N, or as approved.
 - 6. Where operating weight differs from installed weight, provide built-in adjustable limit stops to prevent equipment rising when weight is removed. Stops shall not be in contact during normal operation.
- D. Type D: Elastomer Mounting Types/Elastomer Isolators, shall incorporate the following:
 - 1. Bolt holes for bolting to equipment base.
 - 2. Bottom steel plates for bolting or welding to sub-base as required.
 - 3. Unit type design molded in oil-resistant neoprene.
 - 4. Encased in ductile steel or iron casing and capable of withstanding external forces of up to 1.5 g. System to be field bolted or welded to deck with ability to resist forces of 1.5 g.
 - 5. Mason Type ND isolation BR, RBA or as approved.
- E. Type E: Elastomer hanger rod isolators shall incorporate the following:

1. Molded unit type neoprene element with projecting bushing lining rod clearance hole.
 2. Neoprene element to be minimum 1 3/4" thick.
 3. Steel retainer box encasing neoprene mounting.
 4. Clearance between mounting hanger rod and neoprene bushing shall be minimum 1/8".
 5. Requires seismic restraint type III.
 6. Mason Type HD, or as approved.
- F. Type F: Combination spring/elastomer hanger rod isolators to incorporate the following:
1. Spring and neoprene isolator elements in a steel box retainer.
 2. Other characteristics of steel box retainer and hanger rod swing as described for Type C isolators.
 3. Requires seismic restraint type III
 4. Mason Type TPC-30N, or as approved.
- G. Type G: Pad type elastomer mountings to incorporate the following:
1. 0.750" minimum thickness.
 2. 50 psi maximum loading.
 3. Ribbed or waffled design.
 4. 0.10" deflection per pad thickness.
 5. 1/16" galvanized steel plate between multiple layers of pad thickness.
 6. Suitable bearing plate to distribute load.
 7. Requires seismic restraint type II or III as installation requires.
 8. Mason Type Super W, or as approved.
- H. Type H: Pad type elastomer mountings to incorporate the following:
1. Laminated canvas duck and neoprene.
 2. Maximum loading 1000 psi.
 3. Suitable bearing plate to distribute load.
 4. Minimum thickness, 2".
 5. Requires seismic restraint type II or III as installation requires.
 6. Mason Type HL, or as approved.
- I. Type I: Air Mounts: Freestanding, single or multiple, compressed-air bellows.
1. Assembly: Upper and lower steel sections connected by a replaceable, flexible, nylon-reinforced neoprene bellows.
 2. Maximum Natural Frequency: 3 Hz.
 3. Operating Pressure Range: 25 to 100 psig.
 4. Burst Pressure: At least three times the manufacturer's published maximum operating pressure.
 5. Leveling Valves: Minimum of 3 required to maintain leveling within plus or minus 1/8 inch.
 6. Requires seismic restraint type II
- J. Restrained Air Mounts: Housed compressed-air bellows.
1. Assembly: Upper and lower steel sections connected by a replaceable, flexible, nylon-reinforced neoprene bellows and spring, with angle-iron frame having vertical-limit stops and channel-section top with leveling adjustment and attachment screws.
 2. Maximum Natural Frequency: 3 Hz.
 3. Operating Pressure Range: 25 to 100 psig.
 4. Burst Pressure: At least three times the manufacturer's published maximum operating pressure.
 5. Leveling Valves: Minimum of 3 required to maintain leveling within plus or minus 1/8 inch.

6. Requires seismic restraint type II

2.5 EQUIPMENT BASES

A. Integral Structural Steel Base, Type B-1

1. Reinforced, as required, to prevent base flexure at start-up and misalignment of drive and driven units. Centrifugal fan bases complete with motor slide base with double adjustment bolts.. Drilled for drive and driven unit mounting template.
2. Mason Type M, WF, or as approved.

B. Concrete Inertia Base, Type B-2

1. Concrete inertia bases shall be formed in a structural steel perimeter base, reinforced as required to prevent flexure, misalignment of drive and driven unit or stress transfer into equipment. The base shall be complete with motor slide base with double adjustment bolts , pump base elbow supports, and complete with height saving brackets, reinforcing, equipment bolting provisions and isolators.
2. Minimum thickness of the inertia base shall be according to the following tabulation:

Motor Size		Minimum Thickness	
(hp)	(kw)	(in.)	(mm)
5-15	(4-11)	6	(150)
20-50	(15-37)	8	(200)
60-75	(45-55)	10	(250)
100-250	(75-190)	12	(300)
300-500	(220-375)	18	(350)

3. Mason Type K, BMK, or as approved.

C. Curb Mounted Base, Type B-3

1. Rooftop equipment, such as the air cooled chiller, shall be mounted on steel dunnage that is part of the structure and roof construction and are flashed and incorporated into roof's membrane waterproofing system.
2. All spring isolators shall have Type G continuous Super W elastomer mounting pads between the equipment and the isolator plate and bolted through.
3. Curb and equipment shall be capable of withstanding 110mph wind and 1.5 g seismic loads.

D. Type B-4 (Flashable Roof Rail System)

1. Rooftop fans, condensing units, air handlers, etc. shall be mounted on continuous support piers that combines equipment support and isolation into (1) assembly.
2. Rails shall incorporate Type A isolators which are adjustable, removable and interchangeable after equipment has been installed.
3. The system shall maintain the same installed and operating height with or without the equipment load.
4. The system shall have full plywood nailers on all (4) sides, designed to accept membrane waterproofing and shall be dry galvanized or plastic coated.
5. Unit to be supplied with flashing.

6. Roof rail shall be similar to Mason Industries Type R-7000 having a minimum 3" rated static deflection.

E. Type B-6 (Non-Isolated Roof Curb)

1. Non-isolated, curb mounted rooftop equipment shall be mounted on structural curbs that meet the acceleration criteria hereinbefore defined.
2. Curbs shall accept standard 2" roof insulation furnished and installed by the roofing contractor.
3. Non-isolated curbs shall be similar to Mason Industries Type B-6000.

2.6 FLEXIBLE CONNECTORS

A. Elastomer Type FC-1

1. Manufactured of nylon tire cord and EPDM, both molded and cured with hydraulic presses.
2. Straight connectors to have two spheres reinforced with a molded-in external ductile iron ring between spheres.
3. Elbow shall be long radius reducing type.
4. Rated 250 psi. at 170°F. Dropping in a straight line to 170 psi. at 250°F for sizes 1-1/2" to 12", elbows. Elbows shall be rated no less than 90% of straight connections.
5. Sizes 10" and 12" to employ control cables with neoprene end fittings isolated from anchor plates by means of 2" bridge bearing neoprene bushings.
6. Minimum safety factor of 4 to 1 at maximum pressure ratings.
7. Submittals to include test reports, projected life, replacement interval, compression and elongation limits.
8. Mason Types SuperFlex MFNEC, MFLRR, MFTFU, MFTNC, MFTCR, or as approved.

B. Flexible Stainless Hose, Type FC-2

1. Braided flexible metal hose.
2. 2" pipe size and smaller with male nipple fittings.
3. 2-1/2" and larger pipe size with fixed steel flanges.
4. Suitable for operating pressure with 4 to 1 minimum safety factor.
5. Length as shown on drawings.
6. Mason Type BSS, or as approved.

C. Unbraided Exhaust Hose, Type FC-3

1. Low pressure stainless steel angularly corrugated.
2. Fitted with flanged ends.
3. Maximum temperature 1500°F.
4. Mason Type SDL-RF, or as approved.

2.7 SEISMIC RESTRAINTS

- A. All seismic restraints for mechanical equipment shall be capable of safely accepting 1.0 g (1.5 g for designated life safety equipment) external forces without failure, and shall maintain equipment, piping, duct and pressure reducing boxes in a captive position. Seismic restraints shall not short circuit isolation systems or transmit objectionable vibration or noise, and shall be Provided on all equipment as scheduled on drawings.
- B. Submit calculations by a licensed Structural or Civil Engineer substantiating that all equipment mountings and foundations and their seismic restraints can safely accept external forces of 1.0 g load for all rigidly and resiliently supported equipment, piping, and ductwork (1.5 g load for all life safety equipment) without failure and

permanent displacement. Restrain all resiliently mounted piping and ductwork with cable sway bracing by Mason Industries, or approved equal.

C. Seismic Restraint Types

1. Seismic Restraint, Type I
 - a. Shall comply with general characteristics of spring isolators.
 - b. Shall have vertical restraints and are capable of supporting equipment at fixed elevation during equipment erection.
 - c. Shall incorporate seismic snubbing restraint in all directions at specified acceleration loadings.
 - d. System to be field bolted to structure with minimum capability to withstand external forces of 1.5 g.
 - e. Mason Type SSLR, or as approved.
2. Seismic Restraint, Type II
 - a. Each corner or side seismic restraint shall incorporate minimum 5/8" thick pad limit stops. Restraints shall be made of plate, structural members or square metal tubing in a welded assembly, incorporating resilient pads. Angle bumpers are not acceptable. System to be field bolted to deck with 1.5 g acceleration capacity.
 - b. Seismic spring mountings as described above are an acceptable alternative providing all seismic loading requirements are met.
 - c. Mason Industries Type Z-1011, Type Z-1225, or as approved.
3. Seismic Restraint, Type III
 - a. Galvanized steel aircraft cables with end connections made of steel assemblies that swivel to final installation angle and utilize two clamping bolts for cable fastening to equipment and structure. System to be field bolted to deck or overhead structural members or deck with aircraft cable and clamps as per SMACNA guidelines.

PART 3 - EXECUTION

3.1 GENERAL VIBRATION ISOLATION REQUIREMENTS

- A. Install in accordance with manufacturer's written instructions. Vibration isolators must not cause any change of position of equipment or piping resulting in piping stresses or misalignment.
- B. Mechanical equipment shall be isolated from the building structure by means of noise and vibration isolators as scheduled on the drawings or within these specifications.
- C. No rigid connections between equipment and building structure shall be made that degrades the noise and vibration isolation systems herein specified.
- D. Electrical circuit connections to isolated equipment shall be looped to allow free motion of isolated equipment.
- E. The contractor shall not install any equipment, piping or conduit which makes rigid contact with the "building" unless permitted in this Specification. Building includes, but is not limited to, slabs, beams, columns, studs and walls.
- F. Isolation mounting deflection shall be (minimum) as specified or scheduled on drawings.
- G. Coordinate work with other trades to avoid rigid contact with the building. Inform other trades following work, such as plastering or electrical, to avoid any contact which would reduce the vibration isolation.

- H. Bring to the Architect's attention, prior to installation, any conflicts with other trades which will result in unavoidable rigid contact with equipment or piping as described herein, due to inadequate space or other unforeseen conditions. Corrective work necessitated by conflicts after installation shall be at the responsible contractor's expense.
- I. Bring to the Architect's attention any discrepancies between the specifications and field conditions or changes required due to specific equipment selection, prior to installation. Corrective work necessitated by discrepancies after installation shall be at the contractor's expense.
- J. Obtain inspection and approval of any installation to be covered or enclosed, prior to such closure.
- K. Correct, at no additional cost, all installations which are deemed defective in workmanship or materials.

3.2 EQUIPMENT ISOLATION

- A. Mount floor mounted equipment on 4" high concrete housekeeping pads over complete floor area of equipment. Mount vibration isolating devices and related inertia blocks on concrete pad. Key housekeeping pads with hair pins, as required, to be integral with structural slab. Provide approved seismic restraint anchor plates flush with top of housekeeping pad. Concrete work specified in Division 3.

3.3 EQUIPMENT BASES

- A. Fill concrete inertia bases, after installing base frame, with concrete; trowel to a smooth finish.
- B. Concrete Bases: Anchor equipment to concrete base according to supported equipment manufacturer's written instructions for seismic codes at Project site.
 - 1. Install dowel rods to connect concrete base to concrete floor. Unless otherwise indicated, install dowel rods on 18-inch(450-mm) centers around the full perimeter of the base.
 - 2. Install epoxy-coated anchor bolts for supported equipment that extend through concrete base and anchor into structural concrete floor.
 - 3. Place and secure anchorage devices. Use Setting Drawings, templates, diagrams, instructions, and directions furnished with items to be embedded.
 - 4. Install anchor bolts to elevations required for proper attachment to supported equipment.
 - 5. Install anchor bolts according to anchor-bolt manufacturer's written instructions.
 - 6. Cast-in-place concrete materials and placement requirements are specified in Division 3.
- C. Each fan and motor assembly shall be supported on a single structural steel frame. Flexible duct connections shall be provided at inlet and discharge of fan.
- D. The machine to be isolated shall be supported by a structural steel frame or concrete inertia base.
- E. Brackets shall be provided to accommodate the isolator. The vertical position and size of the bracket shall be specified by the isolator manufacturer.
- F. The minimum operating clearance between the equipment frame or rigid steel base frame and the housekeeping pad or floor shall be 1". Minimum operating clearance between concrete inertia and base and housekeeping pad or floor shall be 2".

- G. The equipment structural steel or concrete inertia base shall be placed in position and supported temporarily by blocks or shims, as appropriate, prior to the installation of the machine or isolators.
- H. The isolators shall be installed without raising the machine and frame assembly.
- I. After the entire installation is complete and under full operational load, the isolators shall be adjusted so that the load is transferred from the blocks to the isolators. When all isolators are properly adjusted, the blocks or shims shall be barely free and shall be removed.
- J. Prior to start-up, clean out all foreign matter between bases and equipment. Verify that there are no isolation short circuits in the base, isolators or seismic restraints.
- K. Verify that all installed isolator and mounting systems permit equipment motion in all directions. Adjust or provide additional resilient restraints to flexibly limit start-up equipment lateral motion to 1/4".
- L. Provide flexible connections between all fans and ductwork. Refer to duct accessories section.
- M. When operating weight differs from installed weight, provide built-in limit stops to prevent equipment from rising when weight is removed. Stops shall not be in contact during normal operation.
- N. Additional Requirements
 - 1. Diagonal thrust restraint shall be as described for Type C hanger with the same deflection as specified for the spring mountings. The spring element shall be designed so it can be pre-set for thrust and adjusted to allow for a maximum of 1/4" movement at start and stop. Thrust restraints shall be attached at the centerline of thrust. Restraint shall be Mason Type WB, or as approved.
 - 2. All piping and ductwork to be isolated shall freely pass through walls and floors without rigid connections. Penetration points shall be sleeved or otherwise formed to allow passage of piping or ductwork, and maintain 3/4" to 1 1/4" clearance around the outside surfaces. This clearance space shall be tightly packed with fiberglass (except in cases of fire smoke dampers in ducts), and caulked airtight after installation of piping or ductwork.
 - 3. HVAC piping vertical risers larger than 2" in diameter shall be isolated from the building structure by means of noise and vibration isolation guides and supports.
 - 4. Isolators shall be installed with the isolator hanger box attached to, or hung as close as possible to, the structure. Hanger rods shall be aligned to clear the hanger box.
 - 5. Isolators shall be suspended from substantial structural members, not from slab diaphragm unless specifically permitted.
 - 6. Structural steel for cooling tower or other equipment must support the equipment without excessive deflection of the steel. The structural steel support shall not be resonant with the isolation system resonant frequencies or the driving frequencies of the supported equipment.

3.4 PIPING AND BOILER BREECHING ISOLATORS

- A. All piping and boiler breeching, except fire standpipe systems, are included under this Section.
- B. Installation:
 - 1. Isolate piping, generator stacks/breeching, muffler, domestic hot water breeching and boiler breeching outside of shafts as follows:

- a. All water, steam and glycol piping and breeching in the boiler room and machine rooms.
 - b. Piping where exposed on roof.
 - c. Water piping, stacks, all mufflers and all boiler breeching within 50 ft, or 100 diameters, whichever is greater, from connected equipment.
 - d. All other piping shall be rigidly supported and provided with approved seismic restraints to maintain the piping in a captive position without excessive motion.
 - e. Do not use neoprene components on emergency generator exhaust.
 - f. All emergency generator fuel oil piping and pumps.
2. All piping 2" and over located in mechanical equipment rooms, and for a minimum of fifty (50) feet or 100 pipe diameters, whichever is greater, from connection to vibrating mechanical or electrical equipment, shall be isolated from the building structure by means of noise and vibration isolation hangers, Type F.
 3. Horizontal suspended pipe 2" and smaller and all steam piping shall be suspended by Type E isolator with a minimum 3/8" deflection. Water pipe larger than 2" shall be supported by Type F isolator with a minimum 1", or same static deflection as isolated equipment to which pipe connects, whichever is greater.
 4. Horizontal pipe floor supported at slab shall be supported via Type B, with a minimum static deflection of 1" or same deflection as isolated equipment to which pipe connects, whichever is the greater.
 5. Vertical riser pipe supports shall utilize Type H.
 6. Vertical riser guides, if required, shall avoid direct contact of piping with building.
 7. Pipe anchors, where required, shall utilize resilient pipe anchors, Mason Industries Type ADA, or equivalent, to avoid direct contact of piping with building.
 8. Pipe sway braces, where required, shall utilize two (2) neoprene elements (Type G or H to accommodate tension and compression forces).
 9. Pipe extension and alignment connectors: Provide connectors at riser takeoffs, cooling and heating coils, and elsewhere as required, to accommodate thermal expansion and misalignment.
 10. Adjust, as required, all isolators to eliminate all contact of the isolated rod with the hanger rod box retainer or short circuiting of the spring.
- C. Domestic Water System Isolation :
1. Support all domestic water piping in horizontal and vertical runs with a resilient wrapping or clamp system employing a resilient element of wool, felt, neoprene, or other suitable material; "Trisolators" by Semco or P.R. Isolators by Potter-Roemer, or as approved.
 2. All domestic water piping, size 2" and larger within the building shall be isolated as follows:
 - a. Provide Type F hanger rod isolators with a minimum static deflection of 1" (25 mm) or as scheduled.
 - b. Provide Type B isolators with 1" static deflection, or as scheduled.
 - c. Support water piping in shafts and floor supports` entering shaft with Type G isolators or Type H pad to prevent direct contact of piping with building structure.
 - d. Guide and anchor piping in shafts, as required, with approved mounting designs incorporating Type H pad to prevent direct contact of pipe with building structure.
- D. Isolator Position:

1. Close to building structure.
2. Between building structure and supplementary steel if required.
3. Suspend isolators from rigid and massive support points.
4. All supplementary steel to be sized for a maximum deflection of 0.08 inches (2 mm) at center span.

3.5 GENERAL SEISMIC RESTRAINT REQUIREMENT

- A. All equipment whether isolated or not shall be bolted to structure to allow for minimum 1.0 g of acceleration (1.5 g for life safety equipment). Bolt points and diameter of inserts shall be submitted and verified as part of the contractor's submission for each piece of equipment and stamped and sealed by a civil or structural engineer.
- B. Position all corner or side seismic restraints with equipment at operating weight for proper operation clearance and weld or bolt seismic restraint to seismic anchor plates in housekeeping pad. Install equipment with flexibility in wiring connection. Verify all installed isolators and mounting systems permit equipment motion in all directions. Adjust or provide additional resilient restraints to flexibly limit startup equipment lateral motion to 1/4 inch. Prior to startup, clean out all foreign matter between bases and equipment. Verify that there are no isolation short circuits in the base, isolators or seismic restraints.
- C. All suspended equipment, whether isolated or not, shall be seismically restrained at four points with Type III cable restraints.
- D. Install seismic restraining system Type III taut for overhead suspended unisolated equipment, piping or ductwork, and slack with 2" cable deflection for isolated systems.
- E. Seismically restrain all piping and ductwork with center bracing or Type III restraining system in accordance with SMACNA guidelines to comply as outlined below:
 1. All schedule 10, 20, or 40 piping shall be welded or laterally braced at 40 foot intervals and at turns of more than 4 feet. Longitudinally bracing shall be supplied at 80 foot intervals. No-hub piping shall be braced at 10 foot intervals or at 40 foot intervals if 1.5 g rated couplings are used.
 2. Ductwork to be braced every 30 feet and at every turn and duct run ends. Longitudinal bracing to be provided at 60 foot intervals.
- F. Seismic restraints are not required for the following:
 1. Gas piping less than 1" internal diameter.
 2. Piping in boiler and MER room that is less than 1 1/4" internal diameter. Less than 1 inch for fuel oil piping.
 3. All other piping and electrical conduit less than 2" internal diameter.
 4. All rectangular ducts less than 6 sq. ft. (0.56 m²) in cross sectional area.
 5. All round ducts less than 28" in diameter.
 6. All piping suspended by individual hangers 12" in length or less from the top of the pipe to the bottom of the support for the hanger.
 7. All ducts suspended by hangers 12" (305 mm) or less in length from the point of the attachment to the duct to the bottom of the support for the hanger.
- G. Chimneys, breeching and stacks passing through floors are to be bolted at each floor level or secured above and below each floor with riser clamps or approved vibration isolation systems with seismic restraints.
- H. Chimneys and stacks running horizontally to be braced every 30 ft with Type III restraining system.

- I. Where base anchoring is insufficient to resist seismic forces, supplementary restraining such as seismic restraint system Type III shall be used above system's center of gravity to suitably resist "g" force levels. Vertically mounted tanks may require this additional restraint.
- J. For overhead supported equipment, overstress of the building structure must not occur. Bracing may occur from:
 - 1. upper flanges of structural beams;
 - 2. upper truss chords in bar joist construction at the panel points;
 - 3. cast-in-place inserts or drilled and shielded inserts in concrete structures suitably located away from edges.
- K. Each seismic restraint and snubbing device shall be installed after equipment is installed and fully operational. Each isolation mounting incorporating seismic restraint shall be adjusted to provide the minimum operating clearance in all directions to permit the operation of the equipment without objectionable noise or vibration to any part of the building structure. The operating clearance for equipment seismic restraints shall not be greater than 1/4" (6 mm). Seismic restraints must not result in short-circuiting of isolated equipment.
- L. Pipe risers through cored holes in structure require no additional seismic bracing. (Cored hole diameter to be a maximum of 2 inches larger than pipe outer diameter).

3.6 INSPECTION

- A. On completion of installation of all vibration isolation and seismic restraint devices herein specified, the local representative of the isolation materials manufacturer shall inspect the completed system and report in writing any installation errors, improperly selected isolation or restraint devices, or other faults that could affect the performance of the system. Contractor shall submit a report to the Architect, including the manufacturer's representatives final report, indicating all isolation reported as properly installed or requiring correction, and include a report by the Contractor on steps taken to properly complete the isolation work.

3.7 VIBRATION TESTING

- A. Owner reserves the right to require vibration testing for all new rotating pieces of equipment installed under this contract including pumps and fans. Vibration testing will be performed after the equipment is installed, aligned, dynamically balanced and commissioned. The mechanical contractor shall correct any deficiencies found with the new equipment as identified in the vibration analysis report. The vibration testing shall be as follows:
 - 1. Equipment Vibration testing shall be performed by a certified vibration consultant. A report shall be provided indicating all of the pieces of equipment tested, the results of the tests and any deficiencies found.
 - 2. Vibration allowances shall be as per the latest ASHRAE standard for rotating equipment (ASHRAE 2000 Systems and Equipment), as defined here:
 - 3. Vibration shall not exceed 0.20 inches per second (0.20 in/sec), peak value throughout the operating range of the piece of rotating equipment. (If connected to a VFD.)
 - 4. Measurements for all equipment, at each point shall be taken at each axis (3 axis) throughout the entire operating range of the equipment. (If connected to a VFD.)
 - 5. The test for equipment connected and driven by a Variable Frequency Drive shall include natural (critical) speed testing. Measurements shall be taken throughout the operating range of the equipment starting from a complete

- stop, ramping slowly up to maximum speed, and pausing briefly at the natural frequencies of the equipment/VFD (15, 30, 45 and 60 Hz) during the test.
6. Tests for any piece of equipment not driven by a VFD shall be at their normal operating speed, under normal operating conditions.

3.8 CLEANING

- A. After completing equipment installation, inspect vibration isolation and seismic-control devices. Remove paint splatters and other spots, dirt, and debris.

3.9 DEMONSTRATION

- A. Engage a factory-authorized service representative to train Owner's maintenance personnel to adjust, operate, and maintain air-mounting systems. Refer to Division 23 Section HVAC General Provisions or to Division 1 Section "Closeout Procedures and Demonstration and Training."

3.10 VIBRATION ISOLATION SCHEDULE

Equipment Type	Horsepower and Other	RPM	Base Type	Isolator Type	Min. Defl., in.
Chillers			-	B	
Rotary, screw	All	All	-	B	1.50
Air Compressors and vacuum pumping					
Tank-mounted horizontal	Up to 10	All	-	A or C	1.50
	15 & up	All	B-2	A or C	1.50
Tank-mounted vertical	All	All	B-2	A or C	1.50
Base-mounted	All	All	B-2	A or C	1.50
Large reciprocating	All	All	B-2	A or C	1.50
Pumps					
Close-coupled	Up to 7.5	All	B-2	A or C	.75
	10 & up	All	B-2	A or C	1.50
Large in-line	5 to 25	All	-	A or C	1.50
	30 & up	All	-	A or C	1.50
End suction and split case	Up to 40	All	B-2	A or C	1.50
	50 to 125	All	B-2	A or C	1.50
	150 & up	All	B-2	A or C	2.50
Boilers	All	All	B-1	B	1.50
Fans and Fan Sections					
Up to 22 in. diameter	All	All	-	A or C	.75
24 in. diameter	Up to 2 in. s.p.	Up to 300	B-2	A or C	3.50
		300 to 500	C	A or C	2.50
		501 & up	B	A or C	1.50
	2.1 in s.p and up	Up to 300	B-2	A or C	3.50
		300 to 500	C	A or C	2.50

		501 & up	B	A or C	1.50	
Centrifugal Fans						
Up to 22 in. diameter	All	All	B-1	A or C	.75	
24 in. diameter and up	Up to 40	Up to 300	B-1	A or C	3.50	
		300 to 500	B-1	A or C	2.50	
		501 & up	B-1	A or C	1.5	
	50 and up	Up to 300	B-2	A or C	3.50	
		300 to 500	B-2	A or C	2.50	
Propeller Fans						
Wall-mounted	All	All	-	G	0.25	
Air Cooled Chillers	On Roof	All	All	-	A	1.50
Packaged AHU						
All	Up to 10	All	-	A	1.0	
	15 and up to 4 in. s.p.	Up to 300	-	A	3.50	
		301 to 500	-	A	2.50	
		501 & up	-	A	1.50	
	15 and up, 4 in. s.p. & up	Up to 300	B-2	A	3.50	
		301 to 500	B-2	A	2.50	
		501 & up	B-2	A	1.50	
Packaged Rooftop Equipment	All	All	B-3	G	2.50	
Ducted Rotating Equipment						
Small fans, fan-powered boxes	Up to 600 cfm	All	-	A	0.50	
	601 cfm & up	All	-	A		

Curb-Mounted Equipment	All	All	B-6	-	-
Engine-Driven Generators & Muffler	All	All	-	A	2.50

1. Pumps mounted at grade do not require inertia bases. Provide Type A isolators.

END OF SECTION

SECTION 23 05 49

NOISE CONTROL AND ACOUSTICAL PERFORMANCE

PART 1 - GENERAL

1.1 RELATED DOCUMENTS

- A. Drawings and General Provisions for Heating, Ventilating and Air Conditioning Work, including General and Supplementary Conditions and Division 1 Specification Sections apply to this Section.
- B. Section 01 81 13 "Sustainable Design Requirements – LEED v4 for Building Design & Construction – New Construction" for sustainable design requirements and detailed sustainable design submittal requirements.
- C. Section 01 74 19 "Construction and Demolition Waste Management and Disposal" for disposal of construction, demolition and packaging waste disposal requirements.

1.2 SUMMARY

- A. It is the objective of this Specification to provide the necessary design requirements for the noise control measures and acoustical performance criteria for mechanical systems.
- B. Work in this section includes the providing of labor, materials, equipment and services necessary for a complete installation of sound control for every mechanical system including piping and ductwork within and on the roof of the building, complete, as shown and specified per the contract documents and all applicable codes and authorities having jurisdiction for the following:
 - 1. Sound attenuating units
 - 2. Sound linings
 - 3. Sound Packing
 - 4. Special cleaning and packaging for all operating rooms and pharmacy attenuating units.
- C. Related section include the following:
 - 1. Mechanical Vibration Isolation and Seismic Control, Section 230548.
- D. Sustainable Building Requirements:
 - 1. The Owner requires the Contractor to implement practices and procedures to meet the project's environmental performance goals, which include achieving LEED version 4 **Certified** level Certification. Specific project goals that may impact this area of work include: use of recycled-content materials; use of locally-manufactured materials; use of low-emitting materials; construction waste recycling; and the implementation of a construction indoor air quality management plan. The Contractor shall ensure that the requirements related to these goals, as defined in the Articles below, are implemented to the fullest extent. Substitutions, or other changes to the work proposed by the Contractor or their Subcontractors, shall not be allowed if such changes compromise the aforementioned environmental goals and LEED certification.

1.3 SUBMITTAL DATA REQUIREMENTS

- A. Submit data for each product indicated.
- B. Sound Traps and Silencers:
 - 1. Including certified test data of sound attenuation and self-generated flow noise.
- C. Sound Linings:
 - 1. Certification that sound lining meets erosion test method described in UL Publication No. 181.
 - 2. Certification that sound lining meets ASTM standards C1071, G21 and G22.
- D. Include product description, list of materials for each service, and locations.
- E. Submit manufacturer's installation instructions.

1.4 CODE AND REFERENCE STANDARDS

- A. Published Specifications' standards, tests or recommended methods of trade, industry or governmental organizations that apply to work in this Section.
- B. Comply with all applicable national, state and local codes. Refer to General Provisions Section for additional reference standards.
- C. ANSI/ASTM C553 - Mineral Fiber Blanket And Felt Insulation.
- D. ANSI/ASTM C612 - Mineral Fiber Block And Board Thermal Insulation.
- E. ASTM E84 - Surface Burning Characteristics Of Building Materials.
- F. NFPA 255 - Surface Burning Characteristics Of Building Materials.
- G. UL 723 - Surface Burning Characteristics Of Building Materials.
- H. UL 181 - Factory-Made Air Ducts And Air Connectors
- I. ASTM C1071-00 - Standard Specification For Fibrous Glass Duct Lining Insulation
- J. ASTM C423-02 - Standard Test Method For Sound Absorption And Sound Absorption Coefficients By The Reverberation Room Method
- K. ASTM E795-00 - Standard Practices For Mounting Test Specimens During Sound Absorption Tests
- L. ASTM C919-02 - Standard Practice For Use Of Sealants In Acoustical Applications
- M. NFPA 90A - Standard For The Installation Of Air-Conditioning And Ventilating Systems
- N. NFPA 90B - Standard For The Installation Of Warm Air Heating And Air-Conditioning Systems
- O. ARI 885-98 - Procedure For Estimating Occupied Space Sound Levels In The Application Of Air Terminals And Air Outlets
- P. ASTM E1414-91 - Standard Test Method For Airborne Sound Attenuation Between Rooms Sharing A Common Ceiling Plenum.

1.5 QUALITY ASSURANCE

- A. Applicator: Company specializing in sound trap construction with five years minimum experience.

B. Acoustical Criteria:

1. Noise levels due to equipment and ductwork shall permit attaining sound pressure levels in all 8 octave bands in occupied spaces conforming to noise Criteria (NC) curves as follows:

Offices	NC 35
Public Areas	NC 40
Operating Rooms	NC 40
Procedure and Examination Rooms	NC 35
Dining Facilities	NC 35

C. MECHANICAL EQUIPMENT ACOUSTICAL DESIGN PERFORMANCE

1. Air Distribution System:

- a. Pressure Reducing Device Noise: Maximum permissible sound-power levels in octave bands of airborne transmission through the combination of grille, registers, diffusers, and terminal units or related pressure reducing devices, when operated at the maximum inlet pressure and cfm in installed condition per plans and specifications shall be as follows:

AIR DISTRIBUTION SYSTEM EQUIPMENT/TERMINAL DEVICE NOISE
 MAX PWL (dB re 10⁻¹² Watt)

Octave Band	NC-30	NC-35	NC-40	NC-45	NC-50+
1	58	62	66	68	70
2	50	56	60	63	66
3	45	49	54	58	62
4	41	46	51	56	61
5	38	43	48	53	58
6	37	42	47	52	57
7	36	41	46	51	56
8	37	42	47	52	57

2. Pressure reducing valve radiated noise, including VAV and CV Boxes.

- a. Maximum permissible radiated sound-power levels in octave bands of pressure reducing valves when operated at the maximum inlet pressure and air quantity in an installed condition over occupied spaces shall be as follows:

RADIATED SOUND POWER (dB re 10⁻¹² WATT)

Octave Band	NC-35	NC-40	NC-45	NC-50+
1	72	76	79	82
2	70	74	77	80
3	61	65	68	71
4	60	64	68	72
5	57	62	68	72
6	56	60	65	70
7	66	70	75	80
8	65	70	75	80

3. Acoustical Performance within Equipment Spaces: Equipment room noise levels and noise transmission to adjacent buildings shall comply with all Federal, State and City Noise Ordinances.

PART 2 - PRODUCTS

2.1 BASE BID MANUFACTURERS

- A. Sound Traps and Silencers:
 - 1. Industrial Acoustics Company
 - 2. United McGill Corporation
 - 3. Semco
 - 4. Vibro-Acoustics
- B. Sound-Linings:
 - 1. Johns-Manville Corp.
 - 2. Owens-Corning Fiberglas Corp.

2.2 DUCT SOUND TRAPS:

- A. Available shape:
 - 1. Rectangular straight with splitters or baffles.
 - 2. Round straight with center bodies or pods.
 - 3. Rectangular elbow with splitters or baffles.
 - 4. Round elbow with center bodies or pods.
 - 5. Rectangular transitional with splitters or baffles.
- B. Factory fabricated.
 - 1. Shell:
 - a. Galvanized steel: minimum 22 USSG (0.85 mm).
 - b. Leakproof at pressure differential of 8 inch wg (200 mm wg).
 - 2. Media:
 - a. Flamespread: maximum 25.
 - b. Fuel contributed and smoke developed: maximum 20.
 - c. Minimum 1.5 lbs per cubic foot (24 kg/m) density glass or mineral fiber packed under 5 percent compression.
 - d. Filler to be inert, vermin and moisture proof.
 - 3. Provide all required duct transition pieces and connections. Connections to match ductwork being connected to.
 - 4. Internal Construction: Galvanized perforated steel baffles: minimum 26 USSG (0.5 mm).
 - 5. Protective Tedlar film shall be provided between air stream and fill to prevent any intermingling of the airstream with the fill material.
 - 6. Silencers for any system and/or equipment serving operating rooms, and any fume hoods or other hazardous exhaust systems shall have no media (packless type attenuators). All fume hood or hazardous exhausts, packless sound attenuators shall be stainless steel when installed in stainless steel ductwork.
 - 7. Net Insertion Ratings: Determined by duct-to-reverberant room test method at design airflow shall be as follows:

SOUND TRAP DYNAMIC INSERTION LOSS (FORWARD FLOW)
 SPECIFICATION TYPES
 (INDUSTRIAL ACOUSTICS COMPANY TYPE AS STANDARD)

Octave Band	IAC Type as Std	2	3	4	5	6
A	3L	5	9	14	23	24
B	5L	7	13	21	29	39
C	7L	13	18	28	40	47

Octave Band	IAC Type as Std	2	3	4	5	6
D	3MS	7	12	19	23	23
E	5MS	10	18	30	42	34
F	7MS	14	24	36	48	44
G	3S	12	16	28	35	36
H	5S	18	24	40	45	46
I	7S	20	35	45	50	48
J	3HL	4	4	7	9	19
K	5HL	6	7	14	19	37
L	3HS	9	14	19	22	28
M	5HS	13	19	26	35	44
N	12TXS	11	19	22	14	11
O	12TXL	8	16	16	7	7
P	8TXLB	14	26	18	14	14

8. Maximum self-generated noise shall be as follows:

SOUND TRAP SELF-GENERATED NOISE AT 2000 FPM MAX PWL
 (dB re 10⁻¹² WATT) (10.2 m/sec)

Octave	Band	2	3	4	5	6
A,B,C, J,K	Type L,HL	51	51	49	47	50
D,E,F	Type MS	54	52	50	47	48
G,H,I,L,M	Type S, HS	69	63	64	61	63
N	Type TXS	34	35	35	35	28
O	Type TXL	22	28	28	25	<20
P	Type TXLB	29	27	32	30	23

9. Certified Tests:
- a. Submit certified test data from approved laboratory for pressure drop and insertion loss ratings.
 - 1) For square or rectangular attenuators: 24 inch x 24 inch (610 mm x 610 mm).
 - 2) For round attenuators 24 inch (610 mm) diameter.
 10. Certification data for pressure drop and net insertion loss based on tests of same attenuator.
 11. Attenuators and tests: subject to inspection upon request of Architect or Engineer.
 12. Similar to Industrial Acoustics Company (IAC).
 13. All operating room packless sound attenuators shall have all surfaces factory cleaned and caulked with VOC free sealants and then shrink wrapped prior to shipment.

2.3 SOUND LINING

- A. Fibrous glass.
- B. Facing for low pressure duct liners.
 1. Airstream Finish: neoprene or acrylic coated 100% coverage with acrylic coating with a United States Environmental Protection Agency registered anti-microbial agent proven resistant to microbial growth per ASTM Standards G21 and G22.

2. Stenciled NFPA 90A and 90B.
 - C. Facing for circular medium and high pressure duct liner: Finish: Perforated 28 percent minimum open area 24 USSG (0.7 mm) sheet metal.
 - D. Where lining could be exposed to weather or other sources of moisture and in medium pressure system, protective Tedlar film shall be provided between air stream and fill to prevent contact of the liner material with moisture.
 - E. Protective Tedlar film shall be protected by a perforated inner sheet metal liner.
 - F. Minimum thickness:
 1. In ductwork less than 10 sq. ft cross section: 1 inch (25 mm).
 2. In ductwork greater than 10 sq. ft cross section: 2 inch (25 mm).
 3. In plenums: 2 inch (50 mm).
 - G. Minimum density:
 1. In ductwork: 1-1/2 lb per cu ft (24 kg/cu m).
 2. In plenums: 3 lb per cu ft (48 kg/cu m).
 - H. Flamespread: maximum 25.
 - I. Fuel contributed and smoke developed: maximum 50.
 - J. Suitable for duct velocity of 5000 fpm (20.5 m/sec).
 - K. Dynamic loss coefficient: maximum 1.2.
 - L. K Factor: maximum 0.25 BTU in/hr/deg F/sq ft (36 mW/m/K).
 - M. Noise reduction coefficient± for 1 inch (25 mm) thick lining: minimum NRC = 0.70 when tested in accordance with ASTM C423 in Type A mounting.
 - N. Similar to Johns Manville Permacote Linacoustic meeting ASTM C1071.
 - O. Adhesive and Sealer:
 1. In conformance with NFPA 90A.
 2. Maximum fire hazard ratings; as specified in insulation.
 3. Adhesive: similar to Benjamin Foster 81-99.
 4. Sealer: similar to Johns Manville Superseal or Benjamin Foster 82-07.
 5. In conformance with ASTM C919.
- 2.4 NON-HARDENING SOUND CAULKING:
- A. Guaranteed to be permanently elastic.
 - B. Similar to Tremco Polybutene.

PART 3 - EXECUTION

3.1 SOUND TRAPS AND SILENCERS:

- A. Install in accordance with manufacturer's recommendations to obtain published performance.
- B. Maximum static pressure loss: refer to schedules.

3.2 SOUND LININGS

- A. Adhere duct liner to duct wall with full coverage of adhesive conforming to ASTM C919.
- B. Secure Insulation with mechanical fasteners per SMACNA, NAIMA or duct liner manufacturer's recommendations. Pin length shall be such as to limit compression of liner.
- C. All exposed edges of duct liner shall be factory or field coated. For systems with air flow in excess of 2,500 fpm (12.7 m/sec) a metal nosing must be installed in all liner leading edges, trailing edges, and at all seams.
- D. Repair all unprotected penetrations, tears and rips in the surface of the liner with liner adhesive meeting ASTM C919 or Johns Manville Superseal.
- E. Dimensions of lined ductwork are clear inside dimensions after lining has been installed.
- F. Provide 28% open perforated metal liner and plastic film, meeting the same fire and smoke characteristics as the duct liner, between air stream and duct liner to prevent any intermingling of the air stream with the liner material, for all medium and high pressure ductwork and for all lined ductwork 25'-0" upstream and downstream from fans and HVAC units.
- G. Extent of ductwork sound linings:
 - 1. Upstream of all exhaust fans for minimum distance of 25'-0".
 - 2. All toilet exhaust branch ducts. Lining can be deleted if duct configuration has at least two 90° elbows between the closest air inlets of the men's and women's toilet rooms.
 - 3. All air transfer and jumper ducts from rooms to return air plenums.
 - 4. Where indicated on drawings.

3.3 TESTS

- A. Sound Traps and Duct Silencers:
 - 1. After installation: measure total system pressure before and after attenuators.
 - 2. If pressure loss exceeds maximum static pressure loss schedules on drawings: at no charge, replace attenuators and/or modify entrance and/or discharge aerodynamic flow to obtain specified performance.

END OF SECTION

This page is intentionally left blank.

SECTION 23 05 53

IDENTIFICATION FOR HVAC PIPING AND EQUIPMENT

PART 1 - GENERAL

1.1 RELATED DOCUMENTS

- A. Drawings and general provisions of the Contract, including General and Supplementary Conditions and Division 01 Specification Sections, apply to this Section.
- B. Section 01 81 13 "Sustainable Design Requirements – LEED v4 for Building Design & Construction – New Construction" for sustainable design requirements and detailed sustainable design submittal requirements.
- C. Section 01 74 19 "Construction and Demolition Waste Management and Disposal" for disposal of construction, demolition and packaging waste disposal requirements.

1.2 SUMMARY

- A. Section Includes:
 - 1. Equipment labels.
 - 2. Warning signs and labels.
 - 3. Pipe labels.
 - 4. Duct labels.
 - 5. Stencils.
 - 6. Valve tags.
 - 7. Warning tags.
- B. Sustainable Building Requirements:
 - 1. The Owner requires the Contractor to implement practices and procedures to meet the project's environmental performance goals, which include achieving LEED version 4 **Certified** level Certification. Specific project goals that may impact this area of work include: use of recycled-content materials; use of locally-manufactured materials; use of low-emitting materials; construction waste recycling; and the implementation of a construction indoor air quality management plan. The Contractor shall ensure that the requirements related to these goals, as defined in the Articles below, are implemented to the fullest extent. Substitutions, or other changes to the work proposed by the Contractor or their Subcontractors, shall not be allowed if such changes compromise the aforementioned environmental goals and LEED certification.

1.3 SUBMITTALS

- A. Product Data: For each type of product indicated.
- B. Samples: For color, letter style, and graphic representation required for each identification material and device.
- C. Equipment Label Schedule: Include a listing of all equipment to be labeled with the proposed content for each label.

- D. Valve numbering scheme.
- E. Valve Schedules: For each piping system to include in maintenance manuals.

1.4 COORDINATION

- A. Coordinate installation of identifying devices with completion of covering and painting of surfaces where devices are to be applied.
- B. Coordinate installation of identifying devices with locations of access panels and doors.
- C. Install identifying devices before installing acoustical ceilings and similar concealment.
- D. Coordinate all unit numbering, designation and label locations with the owner.

PART 2 - PRODUCTS

2.1 EQUIPMENT LABELS

- A. Metal Labels for Equipment:
 - 1. Material and Thickness: Anodized aluminum, 0.032-inch minimum thickness, and having predrilled or stamped holes for attachment hardware.
 - 2. Minimum Label Size: Length and width vary for required label content, but not less than 2-1/2 by 3/4 inch.
 - 3. Minimum Letter Size: 1/4 inch for name of units if viewing distance is less than 24 inches, 1/2 inch for viewing distances up to 72 inches, and proportionately larger lettering for greater viewing distances. Include secondary lettering two-thirds to three-fourths the size of principal lettering.
 - 4. Fasteners: Stainless-steel rivets or self-tapping screws.
 - 5. Adhesive: Contact-type permanent adhesive, compatible with label and with substrate.
- B. Label Content: Include building identification, equipment's Drawing designation or unique equipment number, manufacturer's product name, model number and serial number, capacity, operating and power characteristics, essential data, and labels of tested compliances.
- C. Equipment Label Schedule: For each item of equipment to be labeled, on 8-1/2-by-11-inch (A4) bond paper. Tabulate equipment identification number and identify Drawing numbers where equipment is indicated (plans, details, and schedules), plus the Specification Section number and title where equipment is specified. Equipment schedule shall be included in operation and maintenance data.

2.2 WARNING SIGNS AND LABELS

- A. Material and Thickness: Multilayer, multicolor, plastic labels for mechanical engraving, 1/16 inch thick, and having predrilled holes for attachment hardware.
- B. Letter Color: Black.
- C. Background Color: Yellow.
- D. Maximum Temperature: Able to withstand temperatures up to 160 deg F.

- E. Minimum Label Size: Length and width vary for required label content, but not less than 3 by 5 ¼".
- F. Minimum Letter Size: 1/4 inch for name of units if viewing distance is less than 24 inches, 1/2 inch for viewing distances up to 72 inches, and proportionately larger lettering for greater viewing distances. Include secondary lettering two-thirds to three-fourths the size of principal lettering.
- G. Fasteners: Stainless-steel rivets or self-tapping screws.
- H. Adhesive: Contact-type permanent adhesive, compatible with label and with substrate.
- I. Label Content: Include caution and warning information, plus emergency notification instructions.
- J. Systems that shall include these labels shall include any exhaust system serving exhaust hoods, kitchen exhaust, radioactive exhaust, etc.

2.3 PIPE LABELS

- A. General Requirements for Manufactured Pipe Labels: Preprinted, color-coded, with lettering indicating service, and showing flow direction.
- B. Pretensioned Pipe Labels: Precoiled, semirigid plastic formed to cover full circumference of pipe and to attach to pipe without fasteners or adhesive.
- C. Self-Adhesive Pipe Labels: Printed plastic with contact-type, permanent-adhesive backing.
- D. Pipe Label Contents: Include identification of piping service using same designations or abbreviations as used on Drawings, pipe size, and an arrow indicating flow direction.
 - 1. Flow-Direction Arrows: Integral with piping system service lettering to accommodate both directions or as separate unit on each pipe label to indicate flow direction.
 - 2. Lettering Size: At least 1-1/2 inches high.

2.4 DUCT LABELS

- A. Material and Thickness: Multilayer, multicolor, plastic labels with permanent adhesive.
- B. Letter Color: Black.
- C. Background Color: Refer to Part 3.
- D. Maximum Temperature: Able to withstand temperatures up to 160 deg F.
- E. Minimum Label Size: Length and width vary for required label content, but not less than 2-1/2 by 3/4 inch.
- F. Adhesive: Contact-type permanent adhesive, compatible with label and with substrate.
- G. Duct Label Contents: Include identification of duct service using same designations or abbreviations as used on Drawings, duct size, and an arrow indicating flow direction.

1. Flow-Direction Arrows: Integral with duct system service lettering to accommodate both directions or as separate unit on each duct label to indicate flow direction.
2. Lettering Size: At least 1-1/2 inches high.

2.5 STENCILS

- A. Stencils: Prepared with letter sizes according to ASME A13.1 for piping; minimum letter height of 1-1/4 inches for ducts; and minimum letter height of 3/4 inch for access panel and door labels, equipment labels, and similar operational instructions.
 1. Stencil Material: Fiberboard or metal
 2. Stencil Paint: Exterior, gloss, alkyd enamel black unless otherwise indicated. Paint may be in pressurized spray-can form.
 3. Identification Paint: Exterior, alkyd enamel in colors according to ASME A13.1 unless otherwise indicated.

2.6 VALVE TAGS

- A. Valve Tags: Stamped or engraved with 1/4-inch letters for piping system abbreviation and 1/2-inch numbers.
 1. Tag Material: Brass, 0.032-inch minimum thickness, and having predrilled or stamped holes for attachment hardware.
 2. Fasteners: Brass wire-link or beaded chain; or S-hook.
- B. Valve Schedules: For each piping system, on 8-1/2-by-11-inch bond paper. Tabulate valve number, piping system, system abbreviation (as shown on valve tag), location of valve (room or space), normal-operating position (open, closed, or modulating), and variations for identification. Mark valves for emergency shutoff and similar special uses.
 1. Valve-tag schedule shall be included in operation and maintenance data.

2.7 WARNING TAGS

- A. Warning Tags: Preprinted or partially preprinted, accident-prevention tags, of plasticized card stock with matte finish suitable for writing.
 1. Size: 3 by 5-1/4 inches minimum.
 2. Fasteners: Brass grommet and wire.
 3. Nomenclature: Large-size primary caption such as "DANGER," "CAUTION," or "DO NOT OPERATE."
 4. Color: Yellow background with black lettering.

PART 3 - EXECUTION

3.1 PREPARATION

- A. Clean piping and equipment surfaces of substances that could impair bond of identification devices, including dirt, oil, grease, release agents, and incompatible primers, paints, and encapsulants.

3.2 EQUIPMENT LABEL INSTALLATION

- A. Install or permanently fasten labels on each major item of mechanical equipment.

- B. Locate equipment labels where accessible and visible.

3.3 PIPE LABEL INSTALLATION

- A. Locate pipe labels where piping is exposed or above accessible ceilings in finished spaces; machine rooms; accessible maintenance spaces such as shafts, tunnels, and plenums; and exterior exposed locations as follows:
 - 1. Near each valve and control device.
 - 2. Near each branch connection, excluding short takeoffs for fixtures and terminal units. Where flow pattern is not obvious, mark each pipe at branch.
 - 3. Near penetrations through walls, floors, ceilings, and inaccessible enclosures.
 - 4. At access doors, manholes, and similar access points that permit view of concealed piping.
 - 5. Near major equipment items and other points of origination and termination.
 - 6. Spaced at maximum intervals of 50 feet along each run. Reduce intervals to 25 feet in areas of congested piping and equipment.
 - 7. On piping above removable acoustical ceilings. Omit intermediately spaced labels.
- B. Pipe Label Color Schedule:
 - 1. Chilled-Water Piping:
 - a. Background Color: Blue.
 - b. Letter Color: Black.
 - 2. Heating Water Piping:
 - a. Background Color: Red.
 - b. Letter Color: Black.

3.4 DUCT LABEL INSTALLATION

- A. Install plastic-laminated, self-adhesive duct labels with permanent adhesive on air ducts in the following color codes:
 - 1. Blue: For cold-air supply ducts.
 - 2. Yellow: For hot-air supply ducts.
 - 3. Green: For exhaust-, outside-, relief-, return-, and mixed-air ducts.
 - 4. ASME A13.1 Colors and Designs: For hazardous material exhaust.
- B. Locate labels near points where ducts enter into concealed spaces and at maximum intervals of 50 feet in each space where ducts are exposed or concealed by removable ceiling system.

3.5 VALVE-TAG INSTALLATION

- A. Install tags on valves and control devices in piping systems, except check valves; valves within factory-fabricated equipment units; shutoff valves; faucets; convenience and lawn-watering hose connections; and HVAC terminal devices and similar roughing-in connections of end-use fixtures and units. List tagged valves in a valve schedule.
- B. Valve-Tag Application Schedule: Tag valves according to size, shape, and color scheme and with captions similar to those indicated in the following subparagraphs:
 - 1. Valve-Tag Size and Shape:
 - a. Chilled Water: 1-1/2 inches.
 - b. Hot Water: 1-1/2 inches.

2. Valve-Tag Color:
 - a. Chilled Water: Green.
 - b. Hot Water: Red.
3. Letter Color:
 - a. Chilled Water: White.
 - b. Hot Water: White.

3.6 WARNING-TAG INSTALLATION

- A. Write required message on, and attach warning tags to, equipment and other items where required.

END OF SECTION

SECTION 23 05 93

TESTING, ADJUSTING, AND BALANCING FOR HVAC

PART 1 - GENERAL

1.1 RELATED DOCUMENTS

- A. Drawings and general provisions of the Contract, including General and Supplementary Conditions and Division 01 Specification Sections, apply to this Section.
- B. Section 01 81 13 "Sustainable Design Requirements – LEED v4 for Building Design & Construction – New Construction" for sustainable design requirements and detailed sustainable design submittal requirements.
- C. Section 01 74 19 "Construction and Demolition Waste Management and Disposal" for disposal of construction, demolition and packaging waste disposal requirements.

1.2 SUMMARY

- A. This Section includes TAB to produce design objectives for the following:
 - 1. Air Systems:
 - a. Constant-volume air systems.
 - b. Variable-air-volume systems.
 - c. Exhaust air system.
 - 2. Hydronic Piping Systems:
 - a. Constant-flow systems.
 - b. Variable-flow systems.
 - c. Hot water
 - d. Chilled water.
 - 3. HVAC equipment quantitative-performance settings.
 - 4. Exhaust airflow balancing.
 - 5. Space pressurization testing and adjusting.
 - 6. Vibration measuring.
 - 7. Sound level measuring.
 - 8. Indoor-air quality measuring
 - 9. Verifying that automatic control devices are functioning properly.
 - 10. Reporting results of activities and procedures specified in this Section.
 - 11. Commissioning.
- B. The TAB contractor shall submit all bids to the HVAC Contractor and to the Construction Manager and shall contract directly with the HVAC Contractor.
- C. Sustainable Building Requirements:
 - 1. The Owner requires the Contractor to implement practices and procedures to meet the project's environmental performance goals, which include achieving LEED version 4 **Certified** level Certification. Specific project goals that may impact this area of work include: use of recycled-content materials; use of locally-manufactured materials; use of low-emitting materials; construction waste recycling; and the implementation of a construction indoor air quality

management plan. The Contractor shall ensure that the requirements related to these goals, as defined in the Articles below, are implemented to the fullest extent. Substitutions, or other changes to the work proposed by the Contractor or their Subcontractors, shall not be allowed if such changes compromise the aforementioned environmental goals and LEED certification.

1.3 DEFINITIONS

- A. Adjust: To regulate fluid flow rate and air patterns at the terminal equipment, such as to reduce fan speed or adjust a damper.
- B. Balance: To proportion flows within the distribution system, including submains, branches, and terminals, according to indicated quantities.
- C. Barrier or Boundary: Construction, either vertical or horizontal, such as walls, floors, and ceilings that are designed and constructed to restrict the movement of airflow, smoke, odors, and other pollutants.
- D. Draft: A current of air, when referring to localized effect caused by one or more factors of high air velocity, low ambient temperature, or direction of airflow, whereby more heat is withdrawn from a person's skin than is normally dissipated.
- E. NC: Noise criteria.
- F. Procedure: An approach to and execution of a sequence of work operations to yield repeatable results.
- G. RC: Room criteria.
- H. Report Forms: Test data sheets for recording test data in logical order.
- I. Static Head: The pressure due to the weight of the fluid above the point of measurement. In a closed system, static head is equal on both sides of the pump.
- J. Suction Head: The height of fluid surface above the centerline of the pump on the suction side.
- K. System Effect: A phenomenon that can create undesired or unpredicted conditions that cause reduced capacities in all or part of a system.
- L. System Effect Factors: Allowances used to calculate a reduction of the performance ratings of a fan when installed under conditions different from those presented when the fan was performance tested.
- M. TAB: Testing, adjusting, and balancing.
- N. Terminal: A point where the controlled medium, such as fluid or energy, enters or leaves the distribution system.
- O. Test: A procedure to determine quantitative performance of systems or equipment.
- P. Testing, Adjusting, and Balancing (TAB) Firm: The entity responsible for performing and reporting TAB procedures.

1.4 SUBMITTALS

- A. Qualification Data: Within 15 days from Contractor's Notice to Proceed, submit 4 copies of evidence that TAB firm and this Project's TAB team members meet the qualifications specified in "Quality Assurance" Article.

- B. Contract Documents Examination Report: Within 45 days from Contractor's Notice to Proceed, submit 4 copies of the Contract Documents review report as specified in Part 3.
- C. Strategies and Procedures Plan: Within 60 days from Contractor's Notice to Proceed, submit 4 copies of TAB strategies and step-by-step procedures as specified in Part 3 "Preparation" Article. Include a complete set of report forms intended for use on this Project.
- D. Certified TAB Reports: Submit two copies of reports prepared, as specified in this Section, on approved forms certified by TAB firm.
- E. Sample Report Forms: Submit two sets of sample TAB report forms.
- F. Warranties specified in this Section.

1.5 QUALITY ASSURANCE

- A. TAB Firm Qualifications: Engage a TAB firm certified by AABC or NEBB.
- B. TAB Conference: Meet with Owner's, Architect's and Commissioning Agent representatives on approval of TAB strategies and procedures plan to develop a mutual understanding of the details. Ensure the participation of TAB team members, equipment manufacturers' authorized service representatives, HVAC controls installers, and other support personnel. Provide seven days' advance notice of scheduled meeting time and location.
 - 1. Agenda Items: Include at least the following:
 - a. Submittal distribution requirements.
 - b. The Contract Documents examination report.
 - c. TAB plan.
 - d. Work schedule and Project-site access requirements.
 - e. Coordination and cooperation of trades and subcontractors.
 - f. Coordination of documentation and communication flow.
- C. Certification of TAB Reports: Certify TAB field data reports. This certification includes the following:
 - 1. Review field data reports to validate accuracy of data and to prepare certified TAB reports.
 - 2. Certify that TAB team complied with approved TAB plan and the procedures specified and referenced in this Specification.
- D. TAB Report Forms: Use standard forms from AABC's "National Standards for Testing and Balancing Heating, Ventilating, and Air Conditioning Systems." NEBB's "Procedural Standards for Testing, Adjusting, and Balancing of Environmental Systems." SMACNA's TABB "HVAC Systems - Testing, Adjusting, and Balancing." or TAB firm's forms approved by Architect.
- E. Instrumentation Type, Quantity, and Accuracy: As described in AABC's "National Standards for Testing and Balancing Heating, Ventilating, and Air Conditioning Systems and NEBB's "Procedural Standards for Testing, Adjusting, and Balancing of Environmental Systems," Section II, "Required Instrumentation for NEBB Certification."
- F. Instrumentation Calibration: Calibrate instruments at least every six months or more frequently if required by instrument manufacturer.
 - 1. Keep an updated record of instrument calibration that indicates date of calibration and the name of party performing instrument calibration.

1.6 COORDINATION

- A. Coordinate the efforts of factory-authorized service representatives for systems and equipment, HVAC controls installers, and other mechanics to operate HVAC systems and equipment to support and assist TAB activities.
- B. Notice: Provide seven days' advance notice for each test. Include scheduled test dates and times.
- C. Perform TAB after leakage and pressure tests on air and water distribution systems have been satisfactorily completed.

PART 2 - PRODUCTS

(Not Applicable)

PART 3 - EXECUTION

3.1 EXAMINATION

- A. Examine the Contract Documents to become familiar with Project requirements and to discover conditions in systems' designs that may preclude proper TAB of systems and equipment.
 - 1. Contract Documents are defined in the General and Supplementary Conditions of Contract.
 - 2. Verify that balancing devices, such as test ports, gage cocks, thermometer wells, flow-control devices, balancing valves and fittings, and manual volume dampers, are required by the Contract Documents. Verify that quantities and locations of these balancing devices are accessible and appropriate for effective balancing and for efficient system and equipment operation.
- B. Examine approved submittal data of HVAC systems and equipment.
- C. Examine Project Record Documents described in Division 01 Section "Project Record Documents."
- D. Examine design data, including HVAC system descriptions, statements of design assumptions for environmental conditions and systems' output, and statements of philosophies and assumptions about HVAC system and equipment controls.
- E. Examine equipment performance data including fan and pump curves. Relate performance data to Project conditions and requirements, including system effects that can create undesired or unpredicted conditions that cause reduced capacities in all or part of a system. Calculate system effect factors to reduce performance ratings of HVAC equipment when installed under conditions different from those presented when the equipment was performance tested at the factory. To calculate system effects for air systems, use tables and charts found in AMCA 201, "Fans and Systems," Sections 7 through 10; or in SMACNA's "HVAC Systems--Duct Design," Sections 5 and 6. Compare this data with the design data and installed conditions.
- F. Examine system and equipment installations to verify that they are complete and that testing, cleaning, adjusting, and commissioning specified in individual Sections have been performed.
- G. Examine system and equipment test reports.

- H. Examine HVAC system and equipment installations to verify that indicated balancing devices, such as test ports, gage cocks, thermometer wells, flow-control devices, balancing valves and fittings, and manual volume dampers, are properly installed, and that their locations are accessible and appropriate for effective balancing and for efficient system and equipment operation.
- I. Examine systems for functional deficiencies that cannot be corrected by adjusting and balancing.
- J. Examine HVAC equipment to ensure that clean filters have been installed, bearings are greased, belts are aligned and tight, and equipment with functioning controls is ready for operation.
- K. Examine terminal units, such as variable-air-volume boxes, to verify that they are accessible and their controls are connected and functioning.
- L. Examine plenum ceilings used for return air to verify that they are airtight. Verify that pipe penetrations and other holes are sealed.
- M. Examine strainers for clean screens and proper perforations.
- N. Examine valves (two-way and three-way) for proper installation for their intended function of diverting, varying or mixing fluid flows.
- O. Examine heat-transfer coils for correct piping connections and for clean and straight fins.
- P. Examine system pumps and piping to ensure absence of entrained air in the suction piping.
- Q. Examine all equipment for installation and for properly operating safety interlocks and controls including all boilers, chillers, air handling equipment, pumps, boxes and exhaust system equipment.
- R. Examine automatic temperature system components to verify the following:
 - 1. Dampers, valves, and other controlled devices are operated by the intended controller.
 - 2. Dampers and valves are in the position indicated by the controller.
 - 3. Integrity of valves and dampers for free and full operation and for tightness of fully closed and fully open positions. This includes dampers in multizone units, mixing boxes, and variable-air-volume terminals.
 - 4. Automatic modulating and shutoff valves, including two-way valves and three-way mixing and diverting valves, are properly connected.
 - 5. Thermostats and humidistats are located to avoid adverse effects of sunlight, drafts, and cold walls.
 - 6. Sensors are located to sense only the intended conditions.
 - 7. Sequence of operation for control modes is according to the Contract Documents.
 - 8. Controller set points are set at indicated values.
 - 9. Interlocked systems are operating.
 - 10. Changeover from heating to cooling mode occurs according to indicated values.
- S. Report deficiencies discovered before and during performance of TAB procedures. Observe and record system reactions to changes in conditions. Record default set points if different from indicated values.

3.2 PREPARATION

- A. Prepare a TAB plan that includes strategies and step-by-step procedures.
- B. Complete system readiness checks and prepare system readiness reports. Verify the following:
 - 1. Permanent electrical power wiring is complete.
 - 2. Hydronic systems are filled, clean, and free of air.
 - 3. Automatic temperature-control systems are operational.
 - 4. Equipment and duct access doors are securely closed.
 - 5. Balance, smoke, and fire dampers are open.
 - 6. Isolating and balancing valves are open and control valves are operational.
 - 7. Ceilings are installed in critical areas where air-pattern adjustments are required and access to balancing devices is provided.
 - 8. Windows and doors can be closed so indicated conditions for system operations can be met.
- C. Coordinate all such checks with the owner's commissioning agent.

3.3 GENERAL PROCEDURES FOR TESTING AND BALANCING

- A. Perform testing and balancing procedures on each system according to the procedures contained in AABC's "National Standards for Testing and Balancing Heating, Ventilating, and Air Conditioning Systems", NEBB's "Procedural Standards for Testing, Adjusting, and Balancing of Environmental Systems", SMACNA's TABB "HVAC Systems - Testing, Adjusting, and Balancing" and this Section.
- B. Cut insulation, ducts, pipes, and equipment cabinets for installation of test probes to the minimum extent necessary to allow adequate performance of procedures. After testing and balancing, close probe holes and patch insulation with new materials identical to those removed. Restore vapor barrier and finish according to insulation Specifications for this Project.
- C. Mark equipment and balancing device settings with paint or other suitable, permanent identification material, including damper-control positions, valve position indicators, fan-speed-control levers, and similar controls and devices, to show final settings.
- D. Take and report testing and balancing measurements in inch-pound (IP) units.

3.4 GENERAL PROCEDURES FOR BALANCING AIR SYSTEMS

- A. Prepare test reports for both fans and outlets. Obtain manufacturer's outlet factors and recommended testing procedures. Crosscheck the summation of required outlet volumes with required fan volumes.
- B. Prepare schematic diagrams of systems' "as-built" duct layouts.
- C. For variable-air-volume systems, develop a plan to simulate diversity.
- D. Determine the best locations in main and branch ducts for accurate duct airflow measurements.
- E. Check airflow patterns from the outside-air louvers and dampers and the return- and exhaust-air dampers, through the supply-fan discharge and mixing dampers.
- F. Locate start-stop and disconnect switches, electrical interlocks, and motor starters.

- G. Verify that motor starters are equipped with properly sized thermal protection.
- H. Check dampers for proper position to achieve desired airflow path.
- I. Check for airflow blockages.
- J. Check condensate drains for proper connections and functioning.
- K. Check for proper sealing of air-handling unit components.
- L. Check for proper sealing of air duct system.
- M. When adjustable sheaves are provided with equipment for balancing, this contractor is to replace with fixed sheaves, after balancing is complete.

3.5 PROCEDURES FOR ALL AIR SYSTEMS

- A. Adjust fans to deliver total indicated airflows within the maximum allowable fan speed listed by fan manufacturer.
 - 1. Measure fan static pressures to determine actual static pressure as follows:
 - a. Measure outlet static pressure as far downstream from the fan as practicable and upstream from restrictions in ducts such as elbows and transitions.
 - b. Measure static pressure directly at the fan outlet or through the flexible connection.
 - c. Measure inlet static pressure of single-inlet fans in the inlet duct as near the fan as possible, upstream from flexible connection and downstream from duct restrictions.
 - d. Measure inlet static pressure of double-inlet fans through the wall of the plenum that houses the fan.
 - 2. Measure static pressure across each component that makes up an air-handling unit, and other air-handling and treating equipment.
 - a. Simulate dirty filter operation and record the point at which maintenance personnel must change filters.
 - 3. Measure static pressures entering and leaving other devices such as exposed sound traps and other such equipment, under final balanced conditions. Measure duct riser pressure drops to assimilate the pressure drops of concealed (in shaft) sound attenuators.
 - 4. Compare design data with installed conditions to determine variations in design static pressures versus actual static pressures. Compare actual system effect factors with calculated system effect factors to identify where variations occur. Recommend corrective action to align design and actual conditions.
 - 5. Make required adjustments to pulley sizes, motor sizes, and electrical connections to accommodate fan-speed changes.
 - 6. Do not make fan-speed adjustments that result in motor overload. Consult equipment manufacturers about fan-speed safety factors. Modulate dampers and measure fan-motor amperage to ensure that no overload will occur. Measure amperage in full cooling, full heating, economizer, and any other operating modes to determine the maximum required brake horsepower.
 - 7. When balancing is complete, replace any adjustable sheaves to fixed sheaves.
- B. Adjust volume dampers for main duct, submain ducts, and major branch ducts to indicated airflows within specified tolerances.
 - 1. Measure static pressure at a point downstream from the balancing damper and adjust volume dampers until the proper static pressure is achieved.

- a. Where sufficient space in submain and branch ducts is unavailable for Pitot-tube traverse measurements, measure airflow at terminal outlets and inlets and calculate the total airflow for that zone.
 2. Remeasure each submain and branch duct after all have been adjusted. Continue to adjust submain and branch ducts to indicated airflows within specified tolerances.
- C. Measure terminal outlets and inlets without making adjustments.
1. Measure terminal outlets using a direct-reading hood or outlet manufacturer's written instructions and calculating factors.
- D. Adjust terminal outlets and inlets for each space to indicated airflows within specified tolerances of indicated values. Make adjustments using volume dampers rather than extractors and the dampers at air terminals.
1. Adjust each outlet in same room or space to within specified tolerances of indicated quantities without generating noise levels above the limitations prescribed by the Contract Documents.
 2. Adjust patterns of adjustable outlets for proper distribution without drafts.
- 3.6 PROCEDURES FOR VARIABLE-AIR-VOLUME SYSTEMS
- A. Compensating for Diversity: When the total airflow of all terminal units is more than the indicated airflow of the fan, place a selected number of terminal units at a maximum set-point airflow condition until the total airflow of the terminal units equals the indicated airflow of the fan. Select the reduced airflow terminal units so they are distributed evenly among the branch ducts.
- B. The TAB Contractor shall determine and provide the necessary information to the HVAC Contractor and Air Handling Unit manufacturer so as to determine the size of the motor/fan sheave change required for the TAB Contractor to set the Air Handling Unit performance as follows:
1. The TAB Contractor shall provide all labor and materials to provide a sheave change to operate the air system/return systems at approximately 105%-110% above design air flow. The VAV boxes served by the particular air handling unit shall be indexed to approximately 70% of the maximum flow (system diversity) and the required static pressure with dirty filters used as the system set point. The Variable Frequency Drives (VFD) shall be set at 100% speed.
 2. The replacement sheaves shall be sized and installed by the TAB Contractor and provided by the AHU supplier to match the actual field conditions of both the supply and return fans.
- C. Pressure-Independent, Variable-Air-Volume Systems: After the fan systems have been adjusted, adjust the variable-air-volume systems as follows:
1. Set outside-air dampers at minimum, and return- and exhaust-air dampers at a position that simulates full-cooling load.
 2. Select the terminal unit that is most critical to the supply-fan airflow and static pressure. Measure static pressure. Adjust system static pressure so the entering static pressure for the critical terminal unit is not less than the sum of terminal-unit manufacturer's recommended minimum inlet static pressure plus the static pressure needed to overcome terminal-unit discharge system losses.
 3. Measure total system airflow. Adjust to within indicated airflow.

4. Set terminal units at maximum airflow and adjust controller or regulator to deliver the designed maximum airflow. Use terminal-unit manufacturer's written instructions to make this adjustment. When total airflow is correct, balance the air outlets downstream from terminal units as described for constant-volume air systems.
5. Set terminal units at minimum airflow and adjust controller or regulator to deliver the designed minimum airflow. Check air outlets for a proportional reduction in airflow as described for constant-volume air systems.
 - a. If air outlets are out of balance at minimum airflow, report the condition but leave outlets balanced for maximum airflow.
6. Remeasure the return airflow to the fan while operating at maximum return airflow and minimum outside airflow. Adjust the fan and balance the return-air ducts and inlets as described for constant-volume air systems.
7. Measure static pressure at the most critical terminal unit and adjust the static-pressure controller at the main supply-air sensing station to ensure that adequate static pressure is maintained at the most critical unit.
8. Record the final fan performance data.

3.7 PROCEDURES FOR INDOOR-AIR QUALITY MEASUREMENTS

- A. After air balancing is complete and with HVAC systems operating at indicated conditions, perform indoor-air quality testing.
- B. Observe and record the following conditions for each HVAC system:
 1. The distance between the outside-air intake and the closest exhaust fan discharge, flue termination, or vent termination.
 2. Specified filters are installed. Check for leakage around filters.
 3. Cooling coil drain pans have a positive slope to drain.
 4. Cooling coil condensate drain trap maintains an air seal.
 5. Evidence of water damage.
 6. Insulation in contact with the supply, return, and outside air is dry and clean.
- C. Measure and record indoor conditions served by each Air Handling Unit system. Make measurements at multiple locations served by the system if required to satisfy the following:
 1. Most remote area.
 2. One location per floor.
 3. One location for every 5000 sq. ft. (500 sq. m).
- D. Measure and record the following indoor conditions for each operating room two times at two-hour intervals, and in accordance with ASHRAE 113:
 1. Temperature.
 2. Relative humidity.
 3. Air velocity.
 4. Concentration of carbon dioxide (ppm).
 5. Concentration of carbon monoxide (ppm).
 6. Nitrogen oxides (ppm).
 7. Room Pressurization (in H₂O).

3.8 GENERAL PROCEDURES FOR HYDRONIC SYSTEMS

- A. Prepare test reports with pertinent design data and number in sequence starting at pump to end of system. Check the sum of branch-circuit flows against approved pump flow rate. Correct variations that exceed plus or minus 5 percent.

- B. Prepare schematic diagrams of systems' "as-built" piping layouts.
- C. Prepare hydronic systems for testing and balancing according to the following, in addition to the general preparation procedures specified above:
 - 1. Open all manual valves for maximum flow.
 - 2. Check expansion tank liquid level.
 - 3. Check makeup-water-station pressure gage for adequate pressure for highest vent.
 - 4. Check flow-control valves for specified sequence of operation and set at indicated flow.
 - 5. Set differential-pressure control valves at the specified differential pressure. Do not set at fully closed position when pump is positive-displacement type unless several terminal valves are kept open.
 - 6. Set system controls so automatic valves are wide open to heat exchangers.
 - 7. Check pump-motor load. If motor is overloaded, throttle main flow-balancing device so motor nameplate rating is not exceeded.
 - 8. Check air vents for a forceful liquid flow exiting from vents when manually operated.

3.9 PROCEDURES FOR HYDRONIC SYSTEMS

- A. Measure water flow at pumps. Use the following procedures, except for positive-displacement pumps:
 - 1. Verify impeller size by operating the pump with the discharge valve closed. Read pressure differential across the pump. Convert pressure to head and correct for differences in gage heights. Note the point on manufacturer's pump curve at zero flow and verify that the pump has the intended impeller size.
 - 2. Check system resistance. With all valves open, read pressure differential across the pump and mark pump manufacturer's head-capacity curve. Adjust pump discharge valve until indicated water flow is achieved.
 - 3. Verify pump-motor brake horsepower. Calculate the intended brake horsepower for the system based on pump manufacturer's performance data. Compare calculated brake horsepower with nameplate data on the pump motor. Report conditions where actual amperage exceeds motor nameplate amperage.
 - 4. Report flow rates that are not within plus or minus 5 percent of design.
- B. Set calibrated balancing valves, if installed, at calculated presettings.
- C. Measure flow at all stations and adjust, where necessary, to obtain first balance.
 - 1. System components that have Cv rating or an accurately cataloged flow-pressure-drop relationship may be used as a flow-indicating device.
- D. Measure flow at main balancing station and set main balancing device to achieve flow that is 5 percent greater than indicated flow.
- E. Adjust balancing stations to within specified tolerances of indicated flow rate as follows:
 - 1. Determine the balancing station with the highest percentage over indicated flow.
 - 2. Adjust each station in turn, beginning with the station with the highest percentage over indicated flow and proceeding to the station with the lowest percentage over indicated flow.
 - 3. Record settings and mark balancing devices.

- F. Measure pump flow rate and make final measurements of pump amperage, voltage, rpm, pump heads, and systems' pressures and temperatures including outdoor-air temperature.
- G. Measure the differential-pressure control valve settings existing at the conclusions of balancing.
- H. Adjust all flows through all chillers and boilers.
- I. Adjust all make-up systems for flow such as glycol make-up system.

3.10 PROCEDURES FOR VARIABLE-FLOW HYDRONIC SYSTEMS

- A. Balance systems with automatic two- and three-way mixing control valves by setting systems at maximum flow through heat-exchange terminals and proceed as specified above for hydronic systems.

3.11 PROCEDURES FOR MOTORS

- A. Motors, 1/2 HP and Larger: Test at final balanced conditions and record the following data:
 - 1. Manufacturer, model, and serial numbers.
 - 2. Motor horsepower rating.
 - 3. Motor rpm.
 - 4. Efficiency rating.
 - 5. Nameplate and measured voltage, each phase.
 - 6. Nameplate and measured amperage, each phase.
 - 7. Starter thermal-protection-element rating.
- B. Motors Driven by Variable-Frequency Controllers: Test for proper operation at speeds varying from minimum to maximum. Test the manual bypass for the controller to prove proper operation. Record observations, including controller manufacturer, model and serial numbers, and nameplate data.

3.12 PROCEDURES FOR HEAT-TRANSFER COILS

- A. Water Coils: Measure the following data for each coil:
 - 1. Entering- and leaving-water temperature.
 - 2. Water flow rate.
 - 3. Water pressure drop.
 - 4. Dry-bulb temperature of entering and leaving air.
 - 5. Wet-bulb temperature of entering and leaving air for cooling coils.
 - 6. Airflow.
 - 7. Air pressure drop.

3.13 PROCEDURES FOR TEMPERATURE MEASUREMENTS

- A. During TAB, report the need for adjustment in temperature regulation within the automatic temperature-control system.
- B. Measure indoor wet- and dry-bulb temperatures every other hour for a period of two successive eight-hour days, in each separately controlled zone, to prove correctness of final temperature settings. Measure when the building or zone is occupied.

- C. Measure outside-air, wet- and dry-bulb temperatures.

3.14 PROCEDURES FOR VIBRATION MEASUREMENTS

- A. Use a vibration meter meeting the following criteria:
 - 1. Solid-state circuitry with a piezoelectric accelerometer.
 - 2. Velocity range of 0.1 to 10 inches per second.
 - 3. Displacement range of 1 to 100 mils.
 - 4. Frequency range of at least 0 to 1000 Hz.
 - 5. Capable of filtering unwanted frequencies.
- B. Calibrate the vibration meter before each day of testing.
 - 1. Use a calibrator provided with the vibration meter.
 - 2. Follow vibration meter and calibrator manufacturer's calibration procedures.
- C. Perform vibration measurements when other building and outdoor vibration sources are at a minimum level and will not influence measurements of equipment being tested.
 - 1. Turn off equipment in the building that might interfere with testing.
 - 2. Clear the space of people.
- D. Perform vibration measurements after air and water balancing and equipment testing is complete.
- E. Clean equipment surfaces in contact with the vibration transducer.
- F. Position the vibration transducer according to manufacturer's written instructions and to avoid interference with the operation of the equipment being tested.
- G. Measure and record vibration on rotating equipment over 3 hp.
- H. Measure and record equipment vibration, bearing vibration, equipment base vibration, and building structure vibration. Record velocity and displacement readings in the horizontal, vertical, and axial planes.
 - 1. Pumps:
 - a. Pump Bearing: Drive end and opposite end.
 - b. Motor Bearing: Drive end and opposite end.
 - c. Pump Base: Top and side.
 - d. Building: Floor.
 - e. Piping: To and from the pump after flexible connections.
 - 2. Fans and HVAC Equipment with Fans:
 - a. Fan Bearing: Drive end and opposite end.
 - b. Motor Bearing: Drive end and opposite end.
 - c. Equipment Casing: Top and side.
 - d. Equipment Base: Top and side.
 - e. Building: Floor.
 - f. Ductwork: To and from equipment after flexible connections.
 - g. Piping: To and from equipment after flexible connections.
 - 3. HVAC Equipment with Compressors:
 - a. Compressor Bearing: Drive end and opposite end.
 - b. Motor Bearing: Drive end and opposite end.
 - c. Equipment Casing: Top and side.
 - d. Equipment Base: Top and side.
 - e. Building: Floor.
 - f. Piping: To and from equipment after flexible connections.

- I. For equipment with vibration isolation, take floor measurements with the vibration isolation blocked solid to the floor and with the vibration isolation floating. Calculate and report the differences.
- J. Inspect, measure, and record vibration isolation.
 1. Verify that vibration isolation is installed in the required locations.
 2. Verify that installation is level and plumb.
 3. Verify that isolators are properly anchored.
 4. For spring isolators, measure the compressed spring height, the spring OD, and the travel-to-solid distance.
 5. Measure the operating clearance between each inertia base and the floor or concrete base below. Verify that there is unobstructed clearance between the bottom of the inertia base and the floor.

3.15 TEMPERATURE-CONTROL VERIFICATION

- A. Verify that controllers are calibrated and commissioned.
- B. Check transmitter and controller locations and note conditions that would adversely affect control functions.
- C. Record controller settings and note variances between set points and actual measurements.
- D. Check the operation of limiting controllers (i.e., high- and low-temperature controllers).
- E. Check free travel and proper operation of control devices such as damper and valve operators at all VAV, CV boxes, etc.
- F. Check the sequence of operation of control devices. Note device positions and correlate with airflow and water flow measurements. Note the speed of response to input changes.
- G. Check the interaction of electrically operated switch transducers.
- H. Check the interaction of interlock and lockout systems.
- I. Record voltages of power supply and controller output. Determine whether the system operates on a grounded or nongrounded power supply.
- J. Note operation of electric actuators using spring return for proper fail-safe operations.

3.16 TOLERANCES

- A. Set HVAC system airflow and water flow rates within the following tolerances:
 1. Supply, Return, and Exhaust Fans and Equipment with Fans: Plus 5 to plus 10 percent.
 2. Air Outlets and Inlets: 0 to minus 10 percent.
 3. Heating-Water Flow Rate: 0 to minus 10 percent.
 4. Cooling-Water Flow Rate: 0 to minus 5 percent.

3.17 REPORTING

- A. Initial Construction-Phase Report: Based on examination of the Contract Documents as specified in "Examination" Article, prepare a report on the adequacy

of design for systems' balancing devices. Recommend changes and additions to systems' balancing devices to facilitate proper performance measuring and balancing. Recommend changes and additions to HVAC systems and general construction to allow access for performance measuring and balancing devices.

- B. Status Reports: As Work progresses, prepare reports to describe completed procedures, procedures in progress, and scheduled procedures. Include a list of deficiencies and problems found in systems being tested and balanced. Prepare a separate report for each system and each building floor for systems serving multiple floors.
- C. Commissioning: Attend all commissioning meetings and cooperate fully with the owners commissioning agent. Submit all test reports as requested.

3.18 FINAL REPORT

- A. General: Typewritten, or computer printout in letter-quality font, on standard bond paper, in three-ring binder, tabulated and divided into sections by tested and balanced systems.
- B. Include a certification sheet in front of binder signed and sealed by the certified testing and balancing engineer.
 - 1. Include a list of instruments used for procedures, along with proof of calibration.
- C. Final Report Contents: In addition to certified field report data, include the following:
 - 1. Pump curves.
 - 2. Fan curves.
 - 3. Manufacturers' test data (heat wheels, heat pipes, coils and air handlers).
 - 4. Field test reports prepared by system and equipment installers.
 - 5. Other information relative to equipment performance, but do not include Shop Drawings and Product Data.
- D. General Report Data: In addition to form titles and entries, include the following data in the final report, as applicable:
 - 1. Title page.
 - 2. Name and address of TAB firm.
 - 3. Project name.
 - 4. Project location.
 - 5. Architect's name and address.
 - 6. Engineer's name and address.
 - 7. Contractor's name and address.
 - 8. Report date.
 - 9. Signature of TAB firm who certifies the report.
 - 10. Table of Contents with the total number of pages defined for each section of the report. Number each page in the report.
 - 11. Summary of contents including the following:
 - a. Indicated versus final performance.
 - b. Notable characteristics of systems.
 - c. Description of system operation sequence if it varies from the Contract Documents.
 - 12. Nomenclature sheets for each item of equipment.
 - 13. Data for terminal units, including manufacturer, type size, and fittings.

14. Notes to explain why certain final data in the body of reports varies from indicated values.
 15. Test conditions for fans and pump performance forms including the following:
 - a. Settings for outside-, return-, and exhaust-air dampers.
 - b. Conditions of filters.
 - c. Cooling coil, wet- and dry-bulb conditions.
 - d. Fan drive settings including settings and percentage of maximum pitch diameter.
 - e. Air Flow sensors for variable-air-volume systems.
 - f. Settings for supply-air, static-pressure controller.
 - g. Other system operating conditions that affect performance.
- E. System Diagrams: Include schematic layouts of air and hydronic distribution systems. Present each system with single-line diagram and include the following:
1. Quantities of outside, supply, return, and exhaust airflows.
 2. Water and steam flow rates.
 3. Duct, outlet, and inlet sizes.
 4. Pipe and valve sizes and locations.
 5. Terminal units.
 6. Balancing stations.
 7. Position of balancing devices.
- F. Air-Handling Unit Test Reports: For air-handling units with coils, include the following:
1. Unit Data: Include the following:
 - a. Unit identification.
 - b. Location.
 - c. Make and type.
 - d. Model number and unit size.
 - e. Manufacturer's serial number.
 - f. Unit arrangement and class.
 - g. Discharge arrangement.
 - h. Sheave make, size in inches (mm), and bore.
 - i. Sheave dimensions, center-to-center, and amount of adjustments in inches (mm).
 - j. Number of belts, make, and size.
 - k. Number of filters, type, and size.
 2. Motor Data:
 - a. Make and frame type and size.
 - b. Horsepower and rpm.
 - c. Volts, phase, and hertz.
 - d. Full-load amperage and service factor.
 - e. Sheave make, size in inches (mm), and bore.
 - f. Sheave dimensions, center-to-center, and amount of adjustments in inches (mm).
 3. Test Data (Indicated and Actual Values):
 - a. Total airflow rate in cfm.
 - b. Total system static pressure in inches wg.
 - c. Fan rpm.
 - d. Discharge static pressure in inches wg.
 - e. Filter static-pressure differential in inches wg.
 - f. Heat Pipe or Heat Wheel static-pressure differential in inches wg.
 - g. Cooling coil static-pressure differential in inches wg.

- h. Heating coil static-pressure differential in inches wg.
 - i. Outside airflow in cfm.
 - j. Return airflow in cfm.
 - k. Outside-air damper position.
 - l. Return-air damper position.
 - m. VFD settings.
- G. Apparatus-Coil Test Reports:
- 1. Coil Data:
 - a. System identification.
 - b. Location.
 - c. Coil type.
 - d. Number of rows.
 - e. Fin spacing in fins per inch (mm) o.c.
 - f. Make and model number.
 - g. Face area in sq. ft. (sq. m).
 - h. Tube size in NPS (DN).
 - i. Tube and fin materials.
 - j. Circuiting arrangement.
 - 2. Test Data (Indicated and Actual Values):
 - a. Airflow rate in cfm (L/s).
 - b. Average face velocity in fpm (m/s).
 - c. Air pressure drop in inches wg (Pa).
 - d. Outside-air, wet- and dry-bulb temperatures in deg F (deg C).
 - e. Return-air, wet- and dry-bulb temperatures in deg F (deg C).
 - f. Entering-air, wet- and dry-bulb temperatures in deg F (deg C).
 - g. Leaving-air, wet- and dry-bulb temperatures in deg F (deg C).
 - h. Water flow rate in gpm (L/s).
 - i. Water pressure differential in feet of head or psig (kPa).
 - j. Entering-water temperature in deg F (deg C).
 - k. Leaving-water temperature in deg F (deg C).
 - l. Refrigerant expansion valve and refrigerant types. (Air cooled chiller)
 - m. Refrigerant suction pressure in psig (kPa). (air cooled chiller)
 - n. Refrigerant suction temperature in deg F (deg C). (air cooled chiller)
- H. Fan Test Reports: For supply, return and exhaust fans, include the following:
- 1. Fan Data:
 - a. System identification.
 - b. Location.
 - c. Make and type.
 - d. Model number and size.
 - e. Manufacturer's serial number.
 - f. Arrangement and class.
 - g. Sheave make, size in inches (mm), and bore.
 - h. Sheave dimensions, center-to-center, and amount of adjustments in inches (mm).
 - 2. Motor Data:
 - a. Make and frame type and size.
 - b. Horsepower and rpm.
 - c. Volts, phase, and hertz.
 - d. Full-load amperage and service factor.
 - e. Sheave make, size in inches (mm), and bore.

- f. Sheave dimensions, center-to-center, and amount of adjustments in inches (mm).
 - g. Number of belts, make, and size.
 3. Test Data (Indicated and Actual Values):
 - a. Total airflow rate in cfm (L/s).
 - b. Total system static pressure in inches wg (Pa).
 - c. Fan rpm.
 - d. Discharge static pressure in inches wg (Pa).
 - e. Suction static pressure in inches wg (Pa).
 - I. Round and Rectangular Duct Traverse Reports: Include a diagram with a grid representing the duct cross-section and record the following:
 1. Report Data:
 - a. System and air-handling unit number.
 - b. Location and zone.
 - c. Traverse air temperature in deg F (deg C).
 - d. Duct static pressure in inches wg (Pa).
 - e. Duct size in inches (mm).
 - f. Duct area in sq. ft. (sq. m).
 - g. Indicated airflow rate in cfm (L/s).
 - h. Indicated velocity in fpm (m/s).
 - i. Actual airflow rate in cfm (L/s).
 - j. Actual average velocity in fpm (m/s).
 - k. Barometric pressure in psig (Pa).
 - J. Air-Terminal-Device Reports:
 1. Unit Data:
 - a. System and air-handling unit identification.
 - b. Location and zone.
 - c. Test apparatus used.
 - d. Area served.
 - e. Air-terminal-device make.
 - f. Air-terminal-device number from system diagram.
 - g. Air-terminal-device type and model number.
 - h. Air-terminal-device size.
 - i. Air-terminal-device effective area in sq. ft. (sq. m).
 2. Test Data (Indicated and Actual Values):
 - a. Airflow rate in cfm (L/s).
 - b. Air velocity in fpm (m/s).
 - c. Preliminary airflow rate as needed in cfm (L/s).
 - d. Preliminary velocity as needed in fpm (m/s).
 - e. Final airflow rate in cfm (L/s).
 - f. Final velocity in fpm (m/s).
 - g. Space temperature in deg F (deg C).
 - K. System-Coil Reports: For zone coils and water coils of terminal units, include the following:
 1. Unit Data:
 - a. System and air-handling unit identification.
 - b. Location and zone.
 - c. Room or riser served.
 - d. Coil make and size.
 - e. Flowmeter type.
 2. Test Data (Indicated and Actual Values):

- a. Airflow rate in cfm (L/s).
 - b. Entering-water temperature in deg F (deg C).
 - c. Leaving-water temperature in deg F (deg C).
 - d. Water pressure drop in feet of head or psig (kPa).
 - e. Entering-air temperature in deg F (deg C).
 - f. Leaving-air temperature in deg F (deg C).
- L. Pump Test Reports: Calculate impeller size by plotting the shutoff head on pump curves and include the following:
1. Unit Data:
 - a. Unit identification.
 - b. Location.
 - c. Service.
 - d. Make and size.
 - e. Model and serial numbers.
 - f. Water flow rate in gpm (L/s).
 - g. Water pressure differential in feet of head or psig (kPa).
 - h. Required net positive suction head in feet of head or psig (kPa).
 - i. Pump rpm.
 - j. Impeller diameter in inches (mm).
 - k. Motor make and frame size.
 - l. Motor horsepower and rpm.
 - m. Voltage at each connection.
 - n. Amperage for each phase.
 - o. Full-load amperage and service factor.
 - p. Seal type.
 2. Test Data (Indicated and Actual Values):
 - a. Static head in feet of head or psig (kPa).
 - b. Pump shutoff pressure in feet of head or psig (kPa).
 - c. Actual impeller size in inches (mm).
 - d. Full-open flow rate in gpm (L/s).
 - e. Full-open pressure in feet of head or psig (kPa).
 - f. Final discharge pressure in feet of head or psig (kPa).
 - g. Final suction pressure in feet of head or psig (kPa).
 - h. Final total pressure in feet of head or psig (kPa).
 - i. Final water flow rate in gpm (L/s).
 - j. Voltage at each connection.
 - k. Amperage for each phase.
- M. Vibration Measurement Reports:
1. Date and time of test.
 2. Vibration meter manufacturer, model number, and serial number.
 3. Equipment designation, location, equipment, speed, motor speed, and motor horsepower.
 4. Diagram of equipment showing the vibration measurement locations.
 5. Measurement readings for each measurement location.
 6. Calculate isolator efficiency using measurements taken.
 7. Description of predominant vibration source.
- N. Instrument Calibration Reports:
1. Report Data.
 - a. Instrument type and make.
 - b. Serial number.
 - c. Application.

- d. Dates of use.
- e. Dates of calibration.

3.19 INSPECTIONS

A. Initial Inspection:

1. After testing and balancing are complete, operate each system and randomly check measurements to verify that the system is operating according to the final test and balance readings documented in the Final Report.
2. Randomly check the following for each system:
 - a. Measure airflow of at least 10 percent of air outlets.
 - b. Measure water flow of at least 5 percent of terminals.
 - c. Measure room temperature at each thermostat/temperature sensor. Compare the reading to the set point.
 - d. Measure sound levels at two locations.
 - e. Measure space pressure of at least 10 percent of locations.
 - f. Verify that balancing devices are marked with final balance position.
 - g. Note deviations to the Contract Documents in the Final Report.

END OF SECTION

This page is intentionally left blank.

SECTION 23 07 00

HVAC INSULATION

PART 1 - GENERAL

1.1 RELATED DOCUMENTS

- A. Drawings and general provisions of the Contract, including General and Supplementary Conditions and Division 01 Specification Sections, apply to this Section.
- B. Section 01 81 13 "Sustainable Design Requirements – LEED v4 for Building Design & Construction – New Construction" for sustainable design requirements and detailed sustainable design submittal requirements.
- C. Section 01 74 19 "Construction and Demolition Waste Management and Disposal" for disposal of construction, demolition and packaging waste disposal requirements.

1.2 SUMMARY

- A. Section Includes:
 - 1. Insulation Materials:
 - a. Calcium silicate.
 - b. Flexible elastomeric.
 - c. Mineral fiber (blanket and board).
 - 2. Fire-rated insulation systems.
 - 3. Insulating cements.
 - 4. Adhesives.
 - 5. Mastics.
 - 6. Lagging adhesives.
 - 7. Sealants.
 - 8. Factory-applied jackets.
 - 9. Field-applied fabric-reinforcing mesh.
 - 10. Field-applied cloths.
 - 11. Field-applied jackets.
 - 12. Tapes.
 - 13. Securements.
- B. Related Sections:
 - 1. Division 23 Section "Common Works Results for HVAC."
 - 2. Division 23 Section "Hydronic Pumps."
 - 3. Division 23 Section "Piping."
 - 4. Division 23 Section "Metal Ducts."
- C. Sustainable Building Requirements:
 - 1. The Owner requires the Contractor to implement practices and procedures to meet the project's environmental performance goals, which include achieving LEED version 4 **Certified** level Certification. Specific project goals that may impact this area of work include: use of recycled-content materials; use of locally-manufactured materials; use of low-emitting materials; construction

waste recycling; and the implementation of a construction indoor air quality management plan. The Contractor shall ensure that the requirements related to these goals, as defined in the Articles below, are implemented to the fullest extent. Substitutions, or other changes to the work proposed by the Contractor or their Subcontractors, shall not be allowed if such changes compromise the aforementioned environmental goals and LEED certification.

1.3 SUBMITTALS

- A. Product Data: For each type of product indicated. Include thermal conductivity, thickness, and jackets (both factory and field applied, if any).
- B. Shop Drawings:
 - 1. Detail application of protective shields, saddles, and inserts at hangers for each type of insulation and hanger.
 - 2. Detail attachment and covering of heat tracing inside insulation.
 - 3. Detail insulation application at pipe expansion joints for each type of insulation.
 - 4. Detail insulation application at elbows, fittings, flanges, valves, and specialties for each type of insulation.
 - 5. Detail removable insulation at piping specialties, equipment connections, and access panels.
 - 6. Detail application of field-applied jackets.
 - 7. Detail application at linkages of control devices.
 - 8. Detail field application for each equipment type.
- C. Qualification Data: Provide a firm or individual experienced in installing, erecting, or assembling work similar in material, design, and extent to that indicated for this project, whose work has resulted in construction with a record of successful in-service performance.
- D. Material Test Reports: From a qualified testing agency acceptable to authorities having jurisdiction indicating, interpreting, and certifying test results for compliance of insulation materials, sealers, attachments, cements, and jackets, with requirements indicated. Include dates of tests and test methods employed.
- E. Field quality-control reports.

1.4 QUALITY ASSURANCE

- A. Installer Qualifications: Skilled mechanics who have successfully completed an apprenticeship program or another craft training program certified by the Department of Labor, Bureau of Apprenticeship and Training.
- B. Fire-Test-Response Characteristics: Insulation and related materials shall have fire-test-response characteristics indicated, as determined by testing identical products per ASTM E 84, by a testing and inspecting agency acceptable to authorities having jurisdiction. Factory label insulation and jacket materials and adhesive, mastic, tapes, and cement material containers, with appropriate markings of applicable testing and inspecting agency.
 - 1. Insulation Installed Indoors: Flame-spread index of 25 or less, and smoke-developed index of 50 or less and as tested and certified in accordance with ASTM E-84.
 - 2. Insulation Installed Outdoors: Flame-spread index of 75 or less, and smoke-developed index of 150 or less.

1.5 DELIVERY, STORAGE, AND HANDLING

- A. Packaging: Insulation material containers shall be marked by manufacturer with appropriate ASTM standard designation, type and grade, and maximum use temperature.

1.6 COORDINATION

- A. Coordinate size and location of supports, hangers, and insulation shields specified in Division 23 Section "Hangers and Supports for HVAC Piping and Equipment."
- B. Coordinate clearance requirements with Piping Installer for piping insulation application, Duct Installer for duct insulation application, and Equipment Installer for equipment insulation application. Before preparing piping and ductwork Shop Drawings, establish and maintain clearance requirements for installation of insulation and field-applied jackets and finishes and for space required for maintenance.
- C. Coordinate installation and testing of heat tracing.

1.7 SCHEDULING

- A. Schedule insulation application after pressure testing systems and, where required, after installing and testing heat tracing. Insulation application may begin on segments that have satisfactory test results.
- B. Complete installation and concealment of plastic materials as rapidly as possible in each area of construction.

1.8 DEFINITIONS

- A. Indoor Exposed: Indoor ducts, piping or equipment located in mechanical equipment rooms, penthouse, and in areas which will be visible without removing ceilings or opening access panels.
- B. Indoor Concealed: Indoor ducts, piping or equipment which are not exposed to the weather.
- C. Outdoor: All Ducts, piping or equipment which is exposed to the weather. All piping outdoors is considered to be exposed to the weather

PART 2 - PRODUCTS

2.1 INSULATION MATERIALS

- A. Comply with requirements in Part 3 schedule articles for where insulating materials shall be applied. Refer to paragraph 3.14 for insulation schedules.
- B. Products shall not contain asbestos, lead, mercury, or mercury compounds.
- C. Products that come in contact with stainless steel shall have a leachable chloride content of less than 50 ppm when tested according to ASTM C 871.
- D. Insulation materials for use on austenitic stainless steel shall be qualified as acceptable according to ASTM C 795.
- E. Foam insulation materials shall not use CFC or HCFC blowing agents in the manufacturing process.

- F. Calcium Silicate:
1. Products: Subject to compliance with requirements, provide the following:
 - a. Industrial Insulation Group (The); Thermo-12 Gold.
 2. Preformed Pipe Sections: Flat-, curved-, and grooved-block sections of noncombustible, inorganic, hydrous calcium silicate with a non-asbestos fibrous reinforcement. Comply with ASTM C 533, Type I.
 3. Flat-, curved-, and grooved-block sections of noncombustible, inorganic, hydrous calcium silicate with a non-asbestos fibrous reinforcement. Comply with ASTM C 533, Type I.
 4. Prefabricated Fitting Covers: Comply with ASTM C450 and ASTM C585 for dimensions used in performing insulation to cover valves, elbows, tees and flanges.
- G. Mineral-Fiber Blanket Insulation: Mineral or glass fibers bonded with a thermosetting resin. Comply with ASTM C 553, Type II and ASTM C 1290, Type III with factory-applied FSK jacket. Factory-applied jacket requirements are specified in "Factory-Applied Jackets" Article.
1. Products: Subject to compliance with requirements, provide one of the following:
 - a. Johns Manville; Microlite.
 - b. Knauf Insulation; Duct Wrap.
 - c. Owens Corning; All-Service Duct Wrap.
 - d. Certainteed Corp; Duct Wrap.
- H. Mineral-Fiber Board Insulation: Mineral or glass fibers bonded with a thermosetting resin. Comply with ASTM C 612, Type IA or Type IB. For duct and plenum applications, provide insulation with factory-applied FSK jacket. For equipment applications, provide insulation with factory-applied ASJ. Factory-applied jacket requirements are specified in "Factory-Applied Jackets" Article.
1. Products: Subject to compliance with requirements, provide the following:
 - a. Johns Manville; 800 Series Spin-Glas.
 - b. Knauf Insulation; Insulation Board.
 - c. Owens Corning; Fiberglas 700 Series.
 - d. Certainteed Corp; Commercial Board
- I. High Temperature, Mineral Fiber Blanket Insulation: Mineral or glass fibers bonded with a thermosetting resin. Comply with ASTM C553, type V, without factory applied jacket.
1. Products: Subject to compliance with requirements. Provide the following:
 - a. Johns Manville; HTB 23 Spin-Glas.
 - b. Owens Corning; High temperature flexible batt insulations.
- J. Mineral-Fiber, Preformed Pipe Insulation:
1. Products: Subject to compliance with requirements, provide the following available products that may be incorporated
 - a. Fibrex Insulations Inc.; Coreplus 1200.
 - b. Johns Manville; Micro-Lok.
 - c. Knauf Insulation; 1000 Pipe Insulation.
 - d. Manson Insulation Inc.; Alley-K.
 - e. Owens Corning; Fiberglas Pipe Insulation.
 2. Type I, 850 deg F Materials: Mineral or glass fibers bonded with a thermosetting resin. Comply with ASTM C 547, Type I, Grade A, with factory-applied ASJ-SSL. Factory-applied jacket requirements are specified in "Factory-Applied Jackets" Article.

- K. Mineral-Fiber, Pipe and Tank Insulation: Mineral or glass fibers bonded with a thermosetting resin. Semirigid board material with factory-applied ASJ complying with ASTM C 1393, Type II or Type IIIA Category 2, or with properties similar to ASTM C 612, Type IB. Nominal density is 2.5 lb/cu. ft. or more. Thermal conductivity (k-value) at 100 deg F is 0.29 Btu x in./h x sq. ft. x deg F or less. Factory-applied jacket requirements are specified in "Factory-Applied Jackets" Article.
1. Products: Subject to compliance with requirements, provide the following :
 - a. Johns Manville; MicroFlex.
 - b. Knauf Insulation; Pipe and Tank Insulation.
 - c. Manson Insulation Inc.; AK Flex.
 - d. Owens Corning; Fiberglas Pipe and Tank Insulation.
 - e. Certainteed Corp; CrimpWrap.

2.2 FIRE-RATED INSULATION SYSTEMS

- A. Fire-Rated Board: Structural-grade, press-molded, xonolite calcium silicate, fireproofing board suitable for operating temperatures up to 1700 deg F. Comply with ASTM C 656, Type II, Grade 6. tested and certified to provide a 2-hour fire rating by a NRTL acceptable to authority having jurisdiction.
1. Products: Subject to compliance with requirements, provide the following :
 - a. Johns Manville; Super Firetemp M.
- B. Fire-Rated Blanket: High-temperature, flexible, blanket insulation with FSK jacket that is tested and certified to provide a 2-hour fire rating by a NRTL acceptable to authority having jurisdiction.
1. Products: Subject to compliance with requirements, provide the following :
 - a. CertainTeed Corp.; FlameChek.
 - b. Johns Manville; Firetemp Wrap.
 - c. Nelson Firestop Products; Nelson FSB Flameshield Blanket.
 - d. Thermal Ceramics; FireMaster Duct Wrap.
 - e. 3M; Fire Barrier Wrap Products.
 - f. Unifrax Corporation; FyreWrap.
 - g. Vesuvius; PYROSCAT FP FASTR Duct Wrap.

2.3 INSULATING CEMENTS

- A. Mineral-Fiber Insulating Cement: Comply with ASTM C 195.
1. Products: Subject to compliance with requirements, provide the following :
 - a. Insulco, Division of MFS, Inc.; Triple I.
 - b. P. K. Insulation Mfg. Co., Inc.; Super-Stik.
- B. Expanded or Exfoliated Vermiculite Insulating Cement: Comply with ASTM C 196.
1. Products: Subject to compliance with requirements, provide the following :
 - a. P. K. Insulation Mfg. Co., Inc.; Thermal-V-Kote.
- C. Mineral-Fiber, Hydraulic-Setting Insulating and Finishing Cement: Comply with ASTM C 449/C 449M.
1. Products: Subject to compliance with requirements, provide the following :
 - a. Insulco, Division of MFS, Inc.; SmoothKote.
 - b. P. K. Insulation Mfg. Co., Inc.; PK No. 127, and Quik-Cote.
 - c. Rock Wool Manufacturing Company; Delta One Shot.

2.4 ADHESIVES

- A. Materials shall be compatible with insulation materials, jackets, and substrates and for bonding insulation to itself and to surfaces to be insulated, unless otherwise indicated.
 - B. Cellular-Glass, Adhesive: Solvent-based resin adhesive, with a service temperature range of minus 75 to plus 300 deg F (minus 59 to plus 149 deg C).
 - 1. Products: Subject to compliance with requirements, provide the following:
 - a. Childers Products, Division of ITW; CP-96.
 - b. Foster Products Corporation, H. B. Fuller Company; 81-33.
 - C. Flexible Elastomeric Adhesive: Comply with MIL-A-24179A, Type II, Class I.
 - 1. Products: Subject to compliance with requirements, provide the following:
 - a. Aeroflex USA Inc.; Aero seal.
 - b. Armacell LCC; 520 Adhesive.
 - c. Foster Products Corporation, H. B. Fuller Company; 85-75.
 - d. RBX Corporation; Rubatex Contact Adhesive.
 - D. Mineral-Fiber Adhesive: Comply with MIL-A-3316C, Class 2, Grade A.
 - 1. Products: Subject to compliance with requirements, provide the following:
 - a. Childers Products, Division of ITW; CP-82.
 - b. Foster Products Corporation, H. B. Fuller Company; 85-20.
 - c. ITW TACC, Division of Illinois Tool Works; S-90/80.
 - d. Marathon Industries, Inc.; 225.
 - e. Mon-Eco Industries, Inc.; 22-25.
 - E. ASJ Adhesive, and FSK and PVDC Jacket Adhesive: Comply with MIL-A-3316C, Class 2, Grade A for bonding insulation jacket lap seams and joints.
 - 1. Products: Subject to compliance with requirements, provide the following:
 - a. Childers Products, Division of ITW; CP-82.
 - b. Foster Products Corporation, H. B. Fuller Company; 85-20.
 - c. ITW TACC, Division of Illinois Tool Works; S-90/80.
 - d. Marathon Industries, Inc.; 225.
 - e. Mon-Eco Industries, Inc.; 22-25.
 - F. PVC Jacket Adhesive: Compatible with PVC jacket.
 - 1. Products: Subject to compliance with requirements, provide the following:
 - a. Dow Chemical Company (The); 739, Dow Silicone.
 - b. Johns-Manville; Zeston Perma-Weld, CEEL-TITE Solvent Welding Adhesive.
 - c. P.I.C. Plastics, Inc.; Welding Adhesive.
 - d. Red Devil, Inc.; Celulon Ultra Clear.
 - e. Speedline Corporation; Speedline Vinyl Adhesive.
- 2.5 MASTICS
- A. Materials shall be compatible with insulation materials, jackets, and substrates; comply with MIL-C-19565C, Type II.
 - B. Vapor-Barrier Mastic: Water based; suitable for indoor and outdoor use on below ambient services. All mastics shall have low VOC content in compliance with U.S. Green Building Council/LEED® guidelines.
 - 1. Products: Subject to compliance with requirements, provide the following:
 - a. Childers Products, Division of ITW; CP-35.
 - b. Foster Products Corporation, H. B. Fuller Company; 30-90.
 - c. ITW TACC, Division of Illinois Tool Works; CB-50.
 - d. Marathon Industries, Inc.; 590.

- e. Mon-Eco Industries, Inc.; 55-40.
- f. Vimasco Corporation; 749.
2. Water-Vapor Permeance: ASTM E 96, Procedure B, 0.013 perm at 43-mil dry film thickness.
3. Service Temperature Range: Minus 20 to plus 180 deg F.
4. Solids Content: ASTM D 1644, 59 percent by volume and 71 percent by weight.
5. Color: White.

2.6 LAGGING ADHESIVES

- A. Description: Comply with MIL-A-3316C Class I, Grade A and shall be compatible with insulation materials, jackets, and substrates.
 1. Products: Subject to compliance with requirements, provide the following:
 - a. Childers Products, Division of ITW; CP-52.
 - b. Foster Products Corporation, H. B. Fuller Company; 81-42.
 - c. Marathon Industries, Inc.; 130.
 - d. Mon-Eco Industries, Inc.; 11-30.
 - e. Vimasco Corporation; 136.
 2. Fire-resistant, water-based lagging adhesive and coating for use indoors to adhere fire-resistant lagging cloths over duct, equipment, and pipe insulation.
 3. Service Temperature Range: Minus 50 to plus 180 deg F.
 4. Color: White.

2.7 SEALANTS

- A. Joint Sealants:
- B. FSK and Metal Jacket Flashing Sealants:
 1. Products: Subject to compliance with requirements, provide the following :
 - a. Childers Products, Division of ITW; CP-76-8.
 - b. Foster Products Corporation, H. B. Fuller Company; 95-44.
 - c. Marathon Industries, Inc.; 405.
 - d. Mon-Eco Industries, Inc.; 44-05.
 - e. Vimasco Corporation; 750.
 2. Materials shall be compatible with insulation materials, jackets, and substrates.
 3. Fire- and water-resistant, flexible, elastomeric sealant.
 4. Service Temperature Range: Minus 40 to plus 250 deg F.
 5. Color: Aluminum.
- C. ASJ Flashing Sealants, and Vinyl, PVDC, and PVC Jacket Flashing Sealants:
 1. Products: Subject to compliance with requirements, provide the following :
 - a. Childers Products, Division of ITW; CP-76.
 2. Materials shall be compatible with insulation materials, jackets, and substrates.
 3. Fire- and water-resistant, flexible, elastomeric sealant.
 4. Service Temperature Range: Minus 40 to plus 250 deg F.
 5. Color: White.

2.8 FACTORY-APPLIED JACKETS

- A. Insulation system schedules indicate factory-applied jackets on various applications. When factory-applied jackets are indicated, comply with the following:

1. ASJ: White, kraft-paper, fiberglass-reinforced scrim with vapor barrier aluminum-foil backing; complying with ASTM C 1136, Type I.
2. ASJ-SSL: ASJ with self-sealing, pressure-sensitive, acrylic-based adhesive covered by a removable protective strip; complying with ASTM C 1136, Type I.
3. FSK Jacket: Aluminum-foil vapor barrier, fiberglass-reinforced scrim with kraft-paper backing; complying with ASTM C 1136, Type II.
4. FSP Jacket: Aluminum-foil vapor barrier, fiberglass-reinforced scrim with polyethylene backing; complying with ASTM C 1136, Type II.
5. PVDC Jacket for Indoor Applications: 4-mil- thick, white PVDC biaxially oriented barrier film with a permeance at 0.02 perms when tested according to ASTM E 96 and with a flame-spread index of 5 and a smoke-developed index of 20 when tested according to ASTM E 84.
 - a. Products: Subject to compliance with requirements, provide the following :
 - 1) Dow Chemical Company (The); Saran 540 Vapor Retarder Film and Saran 560 Vapor Retarder Film.

2.9 FIELD-APPLIED FABRIC-REINFORCING MESH

- A. Woven Glass-Fiber Fabric for Pipe Insulation: Approximately 2 oz./sq. yd. with a thread count of 10 strands by 10 strands/sq. inch for covering pipe and pipe fittings.
 1. Products: Subject to compliance with requirements, provide the following :
 - a. Vimasco Corporation; Elastafab 894.
- B. Woven Glass-Fiber Fabric for Duct and Equipment Insulation: Approximately 6 oz./sq. yd. with a thread count of 5 strands by 5 strands/sq. inch for covering equipment.
 1. Products: Subject to compliance with requirements, provide the following :
 - a. Childers Products, Division of ITW; Chil-Glas No. 5.
- C. Woven Polyester Fabric: Approximately 1 oz./sq. yd. with a thread count of 10 strands by 10 strands/sq. inch, in a Leno weave, for duct, equipment, and pipe.
 1. Products: Subject to compliance with requirements, provide the following :
 - a. Foster Products Corporation, H. B. Fuller Company; Mast-A-Fab.
 - b. Vimasco Corporation; Elastafab 894.

2.10 FIELD-APPLIED CLOTHS

- A. Woven Glass-Fiber Fabric: Comply with MIL-C-20079H, Type I, plain weave, and presized a minimum of 8 oz./sq. yd.
 1. Products: Subject to compliance with requirements, provide the following :
 - a. Alpha Associates, Inc.; Alpha-Maritex 84215 and 84217/9485RW, Luben 59.

2.11 FIELD-APPLIED JACKETS

- A. Field-applied jackets shall comply with ASTM C 921, Type I, unless otherwise indicated.
- B. FSK Jacket: Aluminum-foil-face vapor barrier, fiberglass-reinforced scrim with kraft-paper backing.
- C. PVC Jacket: High-impact-resistant, UV-resistant PVC complying with ASTM D 1784, Class 16354-C and ASTM E-84 (25/50); thickness as scheduled; roll stock ready for

shop or field cutting and forming. Thickness is indicated in field-applied jacket schedules.

1. Products: Subject to compliance with requirements, provide the following :
 - a. Johns Manville; Zeston.
 - b. P.I.C. Plastics, Inc.; FG Series.
 - c. Proto PVC Corporation; LoSmoke.
 - d. Speedline Corporation; SmokeSafe.
2. Adhesive: As recommended by jacket material manufacturer.
3. Color: White.
4. Factory-fabricated fitting covers to match jacket if available; otherwise, field fabricate.
 - a. Shapes: 45- and 90-degree, short- and long-radius elbows, tees, valves, flanges, unions, reducers, end caps, soil-pipe hubs, traps, mechanical joints, and P-trap and supply covers for lavatories.
5. Factory-fabricated tank heads and tank side panels.

D. Metal Jacket:

1. Products: Subject to compliance with requirements, provide the following :
 - a. Childers Products, Division of ITW; Metal Jacketing Systems.
 - b. PABCO Metals Corporation; Surefit.
 - c. RPR Products, Inc.; Insul-Mate.
2. Aluminum Jacket: Comply with ASTM B 209 (ASTM B 209M), Alloy 3003, 3005, 3105 or 5005, Temper H-14.
 - a. Sheet and roll stock ready for shop or field sizing.
 - b. Finish and thickness are indicated in field-applied jacket schedules.
 - c. Moisture Barrier for Indoor Applications: 1-mil-thick, heat-bonded polyethylene and kraft paper.
 - d. Moisture Barrier for Outdoor Applications: 2.5-mil-thick Polysurlyn.
 - e. Factory-Fabricated Fitting Covers:
 - 1) Same material, finish, and thickness as jacket.
 - 2) Preformed 2-piece or gore, 45- and 90-degree, short- and long-radius elbows.
 - 3) Tee covers.
 - 4) Flange and union covers.
 - 5) End caps.
 - 6) Beveled collars.
 - 7) Valve covers.
 - 8) Field fabricate fitting covers only if factory-fabricated fitting covers are not available.

E. Self-Adhesive Outdoor Jacket: 60-mil-thick, laminated vapor barrier and waterproofing membrane for installation over insulation located aboveground outdoors; consisting of a rubberized bituminous resin on a crosslaminated polyethylene film covered with whitealuminum-foil facing.

1. Products: Subject to compliance with requirements, provide the following :
 - a. Polyguard; Alumaguard 60.

2.12 TAPES

A. ASJ Tape: White vapor-retarder tape matching factory-applied jacket with acrylic adhesive, complying with ASTM C 1136.

1. Products: Subject to compliance with requirements, provide the following :
 - a. Avery Dennison Corporation, Specialty Tapes Division; Fasson 0835.

- b. Compac Corp.; 104 and 105.
 - c. Ideal Tape Co., Inc., an American Biltrite Company; 428 AWF ASJ.
 - d. Venture Tape; 1540 CW Plus, 1542 CW Plus, and 1542 CW Plus/SQ.
 2. Width: 3 inches.
 3. Thickness: 11.5 mils.
 4. Adhesion: 90 ounces force/inch in width.
 5. Elongation: 2 percent.
 6. Tensile Strength: 40 lbf/inch in width.
 7. ASJ Tape Disks and Squares: Precut disks or squares of ASJ tape.
- B. FSK Tape: Foil-face, vapor-retarder tape matching factory-applied jacket with acrylic adhesive; complying with ASTM C 1136.
 1. Products: Subject to compliance with requirements, provide the following :
 - a. Avery Dennison Corporation, Specialty Tapes Division; Fasson 0827.
 - b. Compac Corp.; 110 and 111.
 - c. Ideal Tape Co., Inc., an American Biltrite Company; 491 AWF FSK.
 - d. Venture Tape; 1525 CW, 1528 CW, and 1528 CW/SQ.
 2. Width: 3 inches.
 3. Thickness: 6.5 mils.
 4. Adhesion: 90 ounces force/inch in width.
 5. Elongation: 2 percent.
 6. Tensile Strength: 40 lbf/inch in width.
 7. FSK Tape Disks and Squares: Precut disks or squares of FSK tape.
- C. PVC Tape: White vapor-retarder tape matching field-applied PVC jacket with acrylic adhesive. Suitable for indoor and outdoor applications.
 1. Products: Subject to compliance with requirements, provide the following :
 - a. Avery Dennison Corporation, Specialty Tapes Division; Fasson 0555.
 - b. Compac Corp.; 130.
 - c. Ideal Tape Co., Inc., an American Biltrite Company; 370 White PVC tape.
 - d. Venture Tape; 1506 CW NS.
 2. Width: 2 inches.
 3. Thickness: 6 mils.
 4. Adhesion: 64 ounces force/inch in width.
 5. Elongation: 500 percent.
 6. Tensile Strength: 18 lbf/inch in width.
- D. Aluminum-Foil Tape: Vapor-retarder tape with acrylic adhesive.
 1. Products: Subject to compliance with requirements, provide the following :
 - a. Avery Dennison Corporation, Specialty Tapes Division; Fasson 0800.
 - b. Compac Corp.; 120.
 - c. Ideal Tape Co., Inc., an American Biltrite Company; 488 AWF.
 - d. Venture Tape; 3520 CW.
 2. Width: 2 inches.
 3. Thickness: 3.7 mils.
 4. Adhesion: 100 ounces force/inch in width.
 5. Elongation: 5 percent.
 6. Tensile Strength: 34 lbf/inch in width.

2.13 SECUREMENTS

- A. Bands:
 1. Products: Subject to compliance with requirements, provide the following :
 - a. Childers Products; Bands.

- b. PABCO Metals Corporation; Bands.
 - c. RPR Products, Inc.; Bands.
 2. Stainless Steel: ASTM A 167 or ASTM A 240/A 240M, Type 304 or Type 316; 0.015 inch thick, 1/2 inch wide with wing or closed seal.
 3. Aluminum: ASTM B 209 (ASTM B 209M), Alloy 3003, 3005, 3105, or 5005; Temper H-14, 0.020 inch thick, 1/2 inch wide with wing or closed seal.
 4. Springs: Twin spring set constructed of stainless steel with ends flat and slotted to accept metal bands. Spring size determined by manufacturer for application.
- B. Insulation Pins and Hangers:
 1. Capacitor-Discharge-Weld Pins: Copper- or zinc-coated steel pin, fully annealed for capacitor-discharge welding, 0.106-inch-diameter shank, length to suit depth of insulation indicated.
 - a. Products: Subject to compliance with requirements, provide the following :
 - 1) AGM Industries, Inc.; CWP-1.
 - 2) GEMCO; CD.
 - 3) Midwest Fasteners, Inc.; CD.
 - 4) Nelson Stud Welding; TPA, TPC, and TPS.
 2. Cupped-Head, Capacitor-Discharge-Weld Pins: Copper- or zinc-coated steel pin, fully annealed for capacitor-discharge welding, 0.135-inch- diameter shank, length to suit depth of insulation indicated with integral 1-1/2-inch galvanized carbon-steel washer.
 - a. Products: Subject to compliance with requirements, provide the following :
 - 1) AGM Industries, Inc.; CWP-1.
 - 2) GEMCO; Cupped Head Weld Pin.
 - 3) Midwest Fasteners, Inc.; Cupped Head.
 - 4) Nelson Stud Welding; CHP.
 3. Metal, Adhesively Attached, Perforated-Base Insulation Hangers: Baseplate welded to projecting spindle that is capable of holding insulation, of thickness indicated, securely in position indicated when self-locking washer is in place. Comply with the following requirements:
 - a. Products: Subject to compliance with requirements, provide the following :
 - 1) AGM Industries, Inc.; Tactoo Insul-Hangers, Series T.
 - 2) GEMCO; Perforated Base.
 - 3) Midwest Fasteners, Inc.; Spindle.
 - b. Baseplate: Perforated, galvanized carbon-steel sheet, 0.030 inch thick by 2 inches square.
 - c. Spindle: Copper- or zinc-coated, low carbon steel Aluminum, fully annealed, 0.106-inch-diameter shank, length to suit depth of insulation indicated.
 - d. Adhesive: Recommended by hanger manufacturer. Product with demonstrated capability to bond insulation hanger securely to substrates indicated without damaging insulation, hangers, and substrates.
 4. Nonmetal, Adhesively Attached, Perforated-Base Insulation Hangers: Baseplate fastened to projecting spindle that is capable of holding insulation, of thickness indicated, securely in position indicated when self-locking washer is in place. Comply with the following requirements:

- a. Products: Subject to compliance with requirements, provide the following :
 - 1) GEMCO; Nylon Hangers.
 - 2) Midwest Fasteners, Inc.; Nylon Insulation Hangers.
 - b. Baseplate: Perforated, nylon sheet, 0.030 inch thick by 1-1/2 inches in diameter.
 - c. Spindle: Nylon, 0.106-inch-diameter shank, length to suit depth of insulation indicated, up to 2-1/2 inches.
 - d. Adhesive: Recommended by hanger manufacturer. Product with demonstrated capability to bond insulation hanger securely to substrates indicated without damaging insulation, hangers, and substrates.
5. Self-Sticking-Base Insulation Hangers: Baseplate welded to projecting spindle that is capable of holding insulation, of thickness indicated, securely in position indicated when self-locking washer is in place. Comply with the following requirements:
- a. Products: Subject to compliance with requirements, provide the following :
 - 1) AGM Industries, Inc.; Tactoo Insul-Hangers, Series TSA.
 - 2) GEMCO; Press and Peel.
 - 3) Midwest Fasteners, Inc.; Self Stick.
 - b. Baseplate: Galvanized carbon-steel sheet, 0.030 inch thick by 2 inches square.
 - c. Spindle: Copper- or zinc-coated, low carbon steel Aluminum, fully annealed, 0.106-inch-diameter shank, length to suit depth of insulation indicated.
 - d. Adhesive-backed base with a peel-off protective cover.
6. Insulation-Retaining Washers: Self-locking washers formed from 0.016-inch-thick, aluminum sheet, with beveled edge sized as required to hold insulation securely in place but not less than 1-1/2 inches (38 mm) in diameter.
- a. Products: Subject to compliance with requirements, provide the following :
 - 1) AGM Industries, Inc.; RC-150.
 - 2) GEMCO; R-150.
 - 3) Midwest Fasteners, Inc.; WA-150.
 - 4) Nelson Stud Welding; Speed Clips.
 - b. Protect ends with capped self-locking washers incorporating a spring steel insert to ensure permanent retention of cap in exposed locations.
7. Nonmetal Insulation-Retaining Washers: Self-locking washers formed from 0.016-inch-thick nylon sheet, with beveled edge sized as required to hold insulation securely in place but not less than 1-1/2 inches in diameter.
- a. Products: Subject to compliance with requirements, provide the following :
 - 1) GEMCO.
 - 2) Midwest Fasteners, Inc.
- C. Staples: Outward-clinching insulation staples, nominal 3/4-inch-wide, stainless steel or Monel.
- D. Wire: 0.062-inch soft-annealed, stainless steel.
1. Manufacturers: Subject to compliance with requirements, provide products by one of the following:

- a. C & F Wire.
- b. Childers Products.
- c. PABCO Metals Corporation.
- d. RPR Products, Inc.

2.14 THERMAL-HANGER SHIELD INSERTS

- A. Description: 100 PSIG minimum, compressive-strength insulation insert encased in sheet metal shield.
- B. Manufacturers:
 1. Carpenter & Paterson, Inc.
 2. ERICO/Michigan Hanger Co.
 3. PHS Industries, Inc.
 4. Pipe Shields, Inc.
 5. Rilco Manufacturing Company, Inc.
 6. Value Engineered Products, Inc.
- C. Insulation-Insert Material for Cold Piping: Water-repellent treated, ASTM C 533 Type I calcium silicate or ASTM C 552, Type II cellular glass with vapor barrier.
- D. Insulation-Insert Material for Hot Piping: Water-repellent treated, ASTM C 533 Type I calcium silicate or ASTM C 552, Type II cellular glass.
- E. For Trapeze or Clamped Systems: Insert and shield shall cover entire circumference of pipe.
- F. For Clevis or Band Hangers: Insert and shield shall cover lower 180 degrees of pipe.
- G. Insert Length: Extend 2 inches beyond sheet metal shield for piping operating below ambient air temperature.

PART 3 - EXECUTION

3.1 EXAMINATION

- A. Examine substrates and conditions for compliance with requirements for installation and other conditions affecting performance of insulation application.
 1. Verify that systems and equipment to be insulated have been tested and are free of defects.
 2. Verify that surfaces to be insulated are clean and dry.
 3. Proceed with installation only after unsatisfactory conditions have been corrected.

3.2 PREPARATION

- A. Surface Preparation: Clean and dry surfaces to receive insulation. Remove materials that will adversely affect insulation application.
- B. Coordinate insulation installation with the trade installing heat tracing. Comply with requirements for heat tracing that apply to insulation.
- C. Mix insulating cements with clean potable water; if insulating cements are to be in contact with stainless-steel surfaces, use demineralized water.

3.3 GENERAL INSTALLATION REQUIREMENTS

- A. Install insulation materials, accessories, and finishes with smooth, straight, and even surfaces; free of voids throughout the length of equipment, ducts and fittings, and piping including fittings, valves, and specialties.
- B. Install insulation materials, forms, vapor barriers or retarders, jackets, and thicknesses required for each item of equipment, duct system, and pipe system as specified in insulation system schedules.
- C. Install accessories compatible with insulation materials and suitable for the service. Install accessories that do not corrode, soften, or otherwise attack insulation or jacket in either wet or dry state.
- D. Install insulation with longitudinal seams at top and bottom of horizontal runs.
- E. Install multiple layers of insulation with longitudinal and end seams staggered.
- F. Do not weld brackets, clips, or other attachment devices to piping, fittings, and specialties.
- G. Keep insulation materials dry during application and finishing.
- H. Install insulation with tight longitudinal seams and end joints. Bond seams and joints with adhesive recommended by insulation material manufacturer.
- I. Install insulation with least number of joints practical.
- J. Where vapor barrier is indicated, seal joints, seams, and penetrations in insulation at hangers, supports, anchors, and other projections with vapor-barrier mastic.
 - 1. Install insulation continuously through hangers and around anchor attachments.
 - 2. For insulation application where vapor barriers are indicated, extend insulation on anchor legs from point of attachment to supported item to point of attachment to structure. Taper and seal ends at attachment to structure with vapor-barrier mastic.
 - 3. Install insert materials and install insulation to tightly join the insert. Seal insulation to insulation inserts with adhesive or sealing compound recommended by insulation material manufacturer.
 - 4. Cover inserts with jacket material matching adjacent pipe insulation. Install shields over jacket, arranged to protect jacket from tear or puncture by hanger, support, and shield.
- K. Apply adhesives, mastics, and sealants at manufacturer's recommended coverage rate and wet and dry film thicknesses.
- L. Install insulation with factory-applied jackets as follows:
 - 1. Draw jacket tight and smooth.
 - 2. Cover circumferential joints with 3-inch-wide strips, of same material as insulation jacket. Secure strips with adhesive and outward clinching staples along both edges of strip, spaced 4 inches o.c.
 - 3. Overlap jacket longitudinal seams at least 1-1/2 inches. Install insulation with longitudinal seams at bottom of pipe. Clean and dry surface to receive self-sealing lap. Staple laps with outward clinching staples along edge at 2 inches o.c.
 - a. For below ambient services, apply vapor-barrier mastic over staples.
 - 4. Cover joints and seams with tape as recommended by insulation material manufacturer to maintain vapor seal.
 - 5. Where vapor barriers are indicated, apply vapor-barrier mastic on seams and joints and at ends adjacent to duct and pipe flanges and fittings.

- M. Cut insulation in a manner to avoid compressing insulation more than 75 percent of its nominal thickness.
- N. Finish installation with systems at operating conditions. Repair joint separations and cracking due to thermal movement.
- O. Repair damaged insulation facings by applying same facing material over damaged areas. Extend patches at least 4 inches beyond damaged areas. Adhere, staple, and seal patches similar to butt joints.
- P. For above ambient services, do not install insulation to the following:
 - 1. Vibration-control devices.
 - 2. Testing agency labels and stamps.
 - 3. Nameplates and data plates.
 - 4. Manholes.
 - 5. Handholes.
 - 6. Cleanouts.

3.4 PENETRATIONS

- A. Insulation Installation at Roof Penetrations: Install insulation continuously through roof penetrations.
 - 1. Seal penetrations with flashing sealant.
 - 2. For applications requiring only indoor insulation, terminate insulation above roof surface and seal with joint sealant. For applications requiring indoor and outdoor insulation, install insulation for outdoor applications tightly joined to indoor insulation ends. Seal joint with joint sealant.
 - 3. Extend jacket of outdoor insulation outside roof flashing at least 2 inches (50 mm) below top of roof flashing.
 - 4. Seal jacket to roof flashing with flashing sealant.
- B. Insulation Installation at Underground Exterior Wall Penetrations: Terminate insulation flush with sleeve seal. Seal terminations with flashing sealant.
- C. Insulation Installation at Aboveground Exterior Wall Penetrations: Install insulation continuously through wall penetrations.
 - 1. Seal penetrations with flashing sealant.
 - 2. For applications requiring only indoor insulation, terminate insulation inside wall surface and seal with joint sealant. For applications requiring indoor and outdoor insulation, install insulation for outdoor applications tightly joined to indoor insulation ends. Seal joint with joint sealant.
 - 3. Extend jacket of outdoor insulation outside wall flashing and overlap wall flashing at least 2 inches.
 - 4. Seal jacket to wall flashing with flashing sealant.
- D. Insulation Installation at Interior Wall and Partition Penetrations (That Are Not Fire Rated): Install insulation continuously through walls and partitions.
- E. Insulation Installation at Fire-Rated Wall and Partition Penetrations: Install insulation continuously through penetrations of fire-rated walls and partitions. Terminate insulation at fire damper sleeves for fire-rated wall and partition penetrations. Externally insulate damper sleeves to match adjacent insulation and overlap duct insulation at least 2 inches.
 - 1. Comply with requirements in Division 07 Section "Penetration Firestopping" firestopping and fire-resistive joint sealers.
- F. Insulation Installation at Floor Penetrations:

1. Duct: Install insulation continuously through floor penetrations that are not fire rated. For penetrations through fire-rated assemblies, terminate insulation at fire damper sleeves and externally insulate damper sleeve beyond floor to match adjacent duct insulation. Overlap damper sleeve and duct insulation at least 2 inches.
2. Pipe: Install insulation continuously through floor penetrations.
3. Seal penetrations through fire-rated assemblies. Comply with requirements in Division 07 Section "Penetration Firestopping."

3.5 EQUIPMENT, TANK, AND VESSEL INSULATION INSTALLATION

- A. Mineral Fiber, Pipe and Tank Insulation Installation for Tanks and Vessels: Secure insulation with adhesive and anchor pins and speed washers.
1. Apply adhesives according to manufacturer's recommended coverage rates per unit area, for 100 percent coverage of tank and vessel surfaces.
 2. Groove and score insulation materials to fit as closely as possible to equipment, including contours. Bevel insulation edges for cylindrical surfaces for tight joints. Stagger end joints.
 3. Protect exposed corners with secured corner angles.
 4. Install adhesively attached or self-sticking insulation hangers and speed washers on sides of tanks and vessels as follows:
 - a. Do not weld anchor pins to ASME-labeled pressure vessels.
 - b. Select insulation hangers and adhesive that are compatible with service temperature and with substrate.
 - c. On tanks and vessels, maximum anchor-pin spacing is 3 inches from insulation end joints, and 16 inches o.c. in both directions.
 - d. Do not overcompress insulation during installation.
 - e. Cut and miter insulation segments to fit curved sides and domed heads of tanks and vessels.
 - f. Impale insulation over anchor pins and attach speed washers.
 - g. Cut excess portion of pins extending beyond speed washers or bend parallel with insulation surface. Cover exposed pins and washers with tape matching insulation facing.
 5. Secure each layer of insulation with stainless-steel or aluminum bands. Select band material compatible with insulation materials.
 6. Where insulation hangers on equipment and vessels are not permitted or practical and where insulation support rings are not provided, install a girdle network for securing insulation. Stretch prestressed aircraft cable around the diameter of vessel and make taut with clamps, turnbuckles, or breather springs. Place one circumferential girdle around equipment approximately 6 inches from each end. Install wire or cable between two circumferential girdles 12 inches o.c. Install a wire ring around each end and around outer periphery of center openings, and stretch prestressed aircraft cable radially from the wire ring to nearest circumferential girdle. Install additional circumferential girdles along the body of equipment or tank at a minimum spacing of 48 inches o.c. Use this network for securing insulation with tie wire or bands.
 7. Stagger joints between insulation layers at least 3 inches.
 8. Install insulation in removable segments on equipment access doors, manholes, handholes, and other elements that require frequent removal for service and inspection.
 9. Bevel and seal insulation ends around manholes, handholes, ASME stamps, and nameplates.

10. For equipment with surface temperatures below ambient, apply mastic to open ends, joints, seams, breaks, and punctures in insulation.
- B. Flexible Elastomeric Thermal Insulation Installation for Tanks and Vessels: Install insulation over entire surface of tanks and vessels.
1. Apply 100 percent coverage of adhesive to surface with manufacturer's recommended adhesive.
 2. Seal longitudinal seams and end joints.
- C. Insulation Installation on Pumps:
1. Fabricate metal boxes lined with insulation. Fit boxes around pumps and coincide box joints with splits in pump casings. Fabricate joints with outward bolted flanges. Bolt flanges on 6-inch centers, starting at corners. Install 3/8-inch-diameter fasteners with wing nuts. Alternatively, secure the box sections together using a latching mechanism.
 2. Fabricate boxes from galvanized steel, at least 0.050 inch thick.
 3. For below ambient services, install a vapor barrier at seams, joints, and penetrations. Seal between flanges with replaceable gasket material to form a vapor barrier.
- ### 3.6 GENERAL PIPE INSULATION INSTALLATION
- A. Requirements in this article generally apply to all insulation materials except where more specific requirements are specified in various pipe insulation material installation articles.
- B. Insulation Installation on Fittings, Valves, Strainers, Flanges, and Unions:
1. Install insulation over fittings, valves, strainers, flanges, unions, and other specialties with continuous thermal and vapor-retarder integrity, unless otherwise indicated.
 2. Insulate pipe elbows using preformed fitting insulation or mitered fittings made from same material and density as adjacent pipe insulation. Each piece shall be butted tightly against adjoining piece and bonded with adhesive. Fill joints, seams, voids, and irregular surfaces with insulating cement finished to a smooth, hard, and uniform contour that is uniform with adjoining pipe insulation.
 3. Insulate tee fittings with preformed fitting insulation or sectional pipe insulation of same material and thickness as used for adjacent pipe. Cut sectional pipe insulation to fit. Butt each section closely to the next and hold in place with tie wire. Bond pieces with adhesive.
 4. Insulate valves using preformed fitting insulation or sectional pipe insulation of same material, density, and thickness as used for adjacent pipe. Overlap adjoining pipe insulation by not less than two times the thickness of pipe insulation, or one pipe diameter, whichever is thicker. For valves, insulate up to and including the bonnets, valve stuffing-box studs, bolts, and nuts. Fill joints, seams, and irregular surfaces with insulating cement.
 5. Insulate strainers using preformed fitting insulation or sectional pipe insulation of same material, density, and thickness as used for adjacent pipe. Overlap adjoining pipe insulation by not less than two times the thickness of pipe insulation, or one pipe diameter, whichever is thicker. Fill joints, seams, and irregular surfaces with insulating cement. Insulate strainers so strainer basket flange or plug can be easily removed and replaced without damaging the insulation and jacket. Provide a removable reusable insulation cover. For below ambient services, provide a design that maintains vapor barrier.

6. Insulate flanges and unions using a section of oversized preformed pipe insulation. Overlap adjoining pipe insulation by not less than two times the thickness of pipe insulation, or one pipe diameter, whichever is thicker.
 7. Cover segmented insulated surfaces with a layer of finishing cement and coat with a mastic. Install vapor-barrier mastic for below ambient services and a breather mastic for above ambient services. Reinforce the mastic with fabric-reinforcing mesh. Trowel the mastic to a smooth and well-shaped contour.
 8. For services not specified to receive a field-applied jacket except for flexible elastomeric and polyolefin, install fitted PVC cover over elbows, tees, strainers, valves, flanges, and unions. Terminate ends with PVC end caps. Tape PVC covers to adjoining insulation facing using PVC tape.
 9. Stencil or label the outside insulation jacket of each union with the word "UNION." Match size and color of pipe labels.
- C. Insulate instrument connections for thermometers, pressure gages, pressure temperature taps, test connections, flow meters, sensors, switches, and transmitters on insulated pipes, vessels, and equipment. Shape insulation at these connections by tapering it to and around the connection with insulating cement and finish with finishing cement, mastic, and flashing sealant.
- D. Install removable insulation covers at locations indicated. Installation shall conform to the following:
1. Make removable flange and union insulation from sectional pipe insulation of same thickness as that on adjoining pipe. Install same insulation jacket as adjoining pipe insulation.
 2. When flange and union covers are made from sectional pipe insulation, extend insulation from flanges or union long at least two times the insulation thickness over adjacent pipe insulation on each side of flange or union. Secure flange cover in place with stainless-steel or aluminum bands. Select band material compatible with insulation and jacket.
 3. Construct removable valve insulation covers in same manner as for flanges except divide the two-part section on the vertical center line of valve body.
 4. When covers are made from block insulation, make two halves, each consisting of mitered blocks wired to stainless-steel fabric. Secure this wire frame, with its attached insulation, to flanges with tie wire. Extend insulation at least 2 inches (50 mm) over adjacent pipe insulation on each side of valve. Fill space between flange or union cover and pipe insulation with insulating cement. Finish cover assembly with insulating cement applied in two coats. After first coat is dry, apply and trowel second coat to a smooth finish.
 5. Unless a PVC jacket is indicated in field-applied jacket schedules, finish exposed surfaces with a metal jacket.
- E. Saddles and Shields: Unless otherwise indicated and except as specified in piping system Sections, install the following types:
1. Steel Pip-Covering Protection Saddles (MSS Type 39)): To fill interior voids with insulation that matches adjoining insulation.
 2. Protection Shields (MSS Type 40): Of length recommended in writing by manufacturer to prevent crushing insulation.
 3. Thermal-Hanger Shield Inserts: For supporting insulated pipe. Include steel weight distribution plate for pipe NPS 4 and larger if pipe is installed on rollers.
- 3.7 CALCIUM SILICATE INSULATION INSTALLATION
- A. Insulation Installation on Boiler Breechings and Ducts:

1. Secure single-layer insulation with stainless-steel bands at 12-inch (300-mm) intervals and tighten bands without deforming insulation material.
 2. Install 2-layer insulation with joints tightly butted and staggered at least 3 inches (75 mm). Secure inner layer with wire spaced at 12-inch (300-mm) intervals. Secure outer layer with stainless-steel bands at 12-inch (300-mm) intervals.
 3. On exposed applications without metal jacket, finish insulation surface with a skim coat of mineral-fiber, hydraulic-setting cement. When cement is dry, apply flood coat of lagging adhesive and press on one layer of glass cloth. Overlap edges at least 1 inch (25 mm). Apply finish coat of lagging adhesive over glass cloth. Thin finish coat to achieve smooth, uniform finish.
- B. Insulation Installation on Straight Pipes and Tubes:
1. Secure single-layer insulation with stainless-steel bands at 12-inch (300-mm) intervals and tighten bands without deforming insulation materials.
 2. Install 2-layer insulation with joints tightly butted and staggered at least 3 inches (75 mm). Secure inner layer with wire spaced at 12-inch (300-mm) intervals. Secure outer layer with stainless-steel bands at 12-inch (300-mm) intervals.
 3. Apply a skim coat of mineral-fiber, hydraulic-setting cement to insulation surface. When cement is dry, apply flood coat of lagging adhesive and press on one layer of glass cloth or tape. Overlap edges at least 1 inch (25 mm). Apply finish coat of lagging adhesive over glass cloth or tape. Thin finish coat to achieve smooth, uniform finish.
- C. Insulation Installation on Pipe Flanges:
1. Install preformed pipe insulation to outer diameter of pipe flange.
 2. Make width of insulation section same as overall width of flange and bolts, plus twice the thickness of pipe insulation.
 3. Fill voids between inner circumference of flange insulation and outer circumference of adjacent straight pipe segments with cut sections of block insulation of same material and thickness as pipe insulation.
 4. Finish flange insulation same as pipe insulation.
- D. Insulation Installation on Pipe Fittings and Elbows:
1. Install preformed sections of same material as straight segments of pipe insulation when available. Secure according to manufacturer's written instructions.
 2. When preformed insulation sections of insulation are not available, install mitered sections of calcium silicate insulation. Secure insulation materials with wire or bands.
 3. Finish fittings insulation same as pipe insulation.
- E. Insulation Installation on Valves and Pipe Specialties:
1. Install mitered segments of calcium silicate insulation to valve body. Arrange insulation to permit access to packing and to allow valve operation without disturbing insulation.
 2. Install insulation to flanges as specified for flange insulation application.
 3. Finish valve and specialty insulation same as pipe insulation.
- 3.8 FLEXIBLE ELASTOMERIC INSULATION INSTALLATION
- A. Seal longitudinal seams and end joints with manufacturer's recommended adhesive to eliminate openings in insulation that allow passage of air to surface being insulated.

- B. Insulation Installation on Pipe Flanges:
 - 1. Install pipe insulation to outer diameter of pipe flange.
 - 2. Make width of insulation section same as overall width of flange and bolts, plus twice the thickness of pipe insulation.
 - 3. Fill voids between inner circumference of flange insulation and outer circumference of adjacent straight pipe segments with cut sections of sheet insulation of same thickness as pipe insulation.
 - 4. Secure insulation to flanges and seal seams with manufacturer's recommended adhesive to eliminate openings in insulation that allow passage of air to surface being insulated.
- C. Insulation Installation on Pipe Fittings and Elbows:
 - 1. Install mitered sections of pipe insulation.
 - 2. Secure insulation materials and seal seams with manufacturer's recommended adhesive to eliminate openings in insulation that allow passage of air to surface being insulated.
- D. Insulation Installation on Valves and Pipe Specialties:
 - 1. Install preformed valve covers manufactured of same material as pipe insulation when available.
 - 2. When preformed valve covers are not available, install cut sections of pipe and sheet insulation to valve body. Arrange insulation to permit access to packing and to allow valve operation without disturbing insulation.
 - 3. Install insulation to flanges as specified for flange insulation application.
 - 4. Secure insulation to valves and specialties and seal seams with manufacturer's recommended adhesive to eliminate openings in insulation that allow passage of air to surface being insulated.

3.9 MINERAL-FIBER INSULATION INSTALLATION

- A. Insulation Installation on Straight Pipes and Tubes:
 - 1. Secure each layer of preformed pipe insulation to pipe with wire or bands and tighten bands without deforming insulation materials.
 - 2. Where vapor barriers are indicated, seal longitudinal seams, end joints, and protrusions with vapor-barrier mastic and joint sealant.
 - 3. For insulation with factory-applied jackets on above ambient surfaces, secure laps with outward clinched staples at 6 inches o.c.
 - 4. For insulation with factory-applied jackets on below ambient surfaces, do not staple longitudinal tabs but secure tabs with additional adhesive as recommended by insulation material manufacturer and seal with vapor-barrier mastic and flashing sealant.
- B. Insulation Installation on Pipe Flanges:
 - 1. Install preformed pipe insulation to outer diameter of pipe flange.
 - 2. Make width of insulation section same as overall width of flange and bolts, plus twice the thickness of pipe insulation.
 - 3. Fill voids between inner circumference of flange insulation and outer circumference of adjacent straight pipe segments with mineral-fiber blanket insulation.
 - 4. Install jacket material with manufacturer's recommended adhesive, overlap seams at least 1 inch (25 mm), and seal joints with flashing sealant.
- C. Insulation Installation on Pipe Fittings and Elbows:
 - 1. Install preformed sections of same material as straight segments of pipe insulation when available.

2. When preformed insulation elbows and fittings are not available, install mitered sections of pipe insulation, to a thickness equal to adjoining pipe insulation. Secure insulation materials with wire or bands.
- D. Insulation Installation on Valves and Pipe Specialties:
1. Install preformed sections of same material as straight segments of pipe insulation when available.
 2. When preformed sections are not available, install mitered sections of pipe insulation to valve body.
 3. Arrange insulation to permit access to packing and to allow valve operation without disturbing insulation.
 4. Install insulation to flanges as specified for flange insulation application.
- E. Blanket Insulation Installation on Ducts and Plenums: Secure with adhesive and insulation pins.
1. Apply adhesives according to manufacturer's recommended coverage rates per unit area, for 100 percent coverage of duct and plenum surfaces.
 2. Apply adhesive to entire circumference of ducts and to all surfaces of fittings and transitions.
 3. Install either capacitor-discharge-weld pins and speed washers or cupped-head, capacitor-discharge-weld pins on sides and bottom of horizontal ducts and sides of vertical ducts as follows:
 - a. On duct sides with dimensions 18 inches and smaller, place pins along longitudinal centerline of duct. Space 3 inches maximum from insulation end joints, and 16 inches o.c.
 - b. On duct sides with dimensions larger than 18 inches, place pins 16 inches o.c. each way, and 3 inches maximum from insulation joints. Install additional pins to hold insulation tightly against surface at cross bracing.
 - c. Pins may be omitted from top surface of horizontal, rectangular ducts and plenums.
 - d. Do not overcompress insulation during installation.
 - e. Impale insulation over pins and attach speed washers.
 - f. Cut excess portion of pins extending beyond speed washers or bend parallel with insulation surface. Cover exposed pins and washers with tape matching insulation facing.
 4. For ducts and plenums with surface temperatures below ambient, install a continuous unbroken vapor barrier. Create a facing lap for longitudinal seams and end joints with insulation by removing 2 inches (50 mm) from 1 edge and 1 end of insulation segment. Secure laps to adjacent insulation section with 1/2-inch (13-mm) outward-clinching staples, 1 inch (25 mm) o.c. Install vapor barrier consisting of factory- or field-applied jacket, adhesive, vapor-barrier mastic, and sealant at joints, seams, and protrusions.
 - a. Repair punctures, tears, and penetrations with tape or mastic to maintain vapor-barrier seal.
 - b. Install vapor stops for ductwork and plenums operating below 50 deg F at 18-foot intervals. Vapor stops shall consist of vapor-barrier mastic applied in a Z-shaped pattern over insulation face, along butt end of insulation, and over the surface. Cover insulation face and surface to be insulated a width equal to 2 times the insulation thickness but not less than 3 inches.

5. Overlap unfaced blankets a minimum of 2 inches on longitudinal seams and end joints. At end joints, secure with steel bands spaced a maximum of 18 inches o.c.
 6. Install insulation on rectangular duct elbows and transitions with a full insulation section for each surface. Install insulation on round and flat-oval duct elbows with individually mitered gores cut to fit the elbow.
 7. Insulate duct stiffeners, hangers, and flanges that protrude beyond insulation surface with 6-inch-wide strips of same material used to insulate duct. Secure on alternating sides of stiffener, hanger, and flange with pins spaced 6 inches o.c.
- F. Board Insulation Installation on Ducts and Plenums: Secure with adhesive and insulation pins.
1. Apply adhesives according to manufacturer's recommended coverage rates per unit area, for 100 percent coverage of duct and plenum surfaces.
 2. Apply adhesive to entire circumference of ducts and to all surfaces of fittings and transitions.
 3. Install either capacitor-discharge-weld pins and speed washers or cupped-head, capacitor-discharge-weld pins on sides and bottom of horizontal ducts and sides of vertical ducts as follows:
 - a. On duct sides with dimensions 18 inches and smaller, place pins along longitudinal centerline of duct. Space 3 inches maximum from insulation end joints, and 16 inches o.c.
 - b. On duct sides with dimensions larger than 18 inches, space pins 16 inches o.c. each way, and 3 inches maximum from insulation joints. Install additional pins to hold insulation tightly against surface at cross bracing.
 - c. Pins may be omitted from top surface of horizontal, rectangular ducts and plenums.
 - d. Do not overcompress insulation during installation.
 - e. Cut excess portion of pins extending beyond speed washers or bend parallel with insulation surface. Cover exposed pins and washers with tape matching insulation facing.
 4. For ducts and plenums with surface temperatures below ambient, install a continuous unbroken vapor barrier. Create a facing lap for longitudinal seams and end joints with insulation by removing 2 inches from 1 edge and 1 end of insulation segment. Secure laps to adjacent insulation section with 1/2-inch outward-clinching staples, 1 inch o.c. Install vapor barrier consisting of factory- or field-applied jacket, adhesive, vapor-barrier mastic, and sealant at joints, seams, and protrusions.
 - a. Repair punctures, tears, and penetrations with tape or mastic to maintain vapor-barrier seal.
 - b. Install vapor stops for ductwork and plenums operating below 50 deg F at 18-foot intervals. Vapor stops shall consist of vapor-barrier mastic applied in a Z-shaped pattern over insulation face, along butt end of insulation, and over the surface. Cover insulation face and surface to be insulated a width equal to 2 times the insulation thickness but not less than 3 inches.
 5. Install insulation on rectangular duct elbows and transitions with a full insulation section for each surface. Groove and score insulation to fit as closely as possible to outside and inside radius of elbows. Install insulation on round and flat-oval duct elbows with individually mitered gores cut to fit the elbow.

6. Insulate duct stiffeners, hangers, and flanges that protrude beyond insulation surface with 6-inch-wide strips of same material used to insulate duct. Secure on alternating sides of stiffener, hanger, and flange with pins spaced 6 inches o.c.

3.10 FIELD-APPLIED JACKET INSTALLATION

- A. Where glass-cloth jackets are indicated, install directly over bare insulation or insulation with factory-applied jackets.
 1. Draw jacket smooth and tight to surface with 2-inch overlap at seams and joints.
 2. Embed glass cloth between two 0.062-inch-thick coats of lagging adhesive.
 3. Completely encapsulate insulation with coating, leaving no exposed insulation.
- B. Where FSK jackets are indicated, install as follows:
 1. Draw jacket material smooth and tight.
 2. Install lap or joint strips with same material as jacket.
 3. Secure jacket to insulation with manufacturer's recommended adhesive.
 4. Install jacket with 1-1/2-inch laps at longitudinal seams and 3-inch-wide joint strips at end joints.
 5. Seal openings, punctures, and breaks in vapor-retarder jackets and exposed insulation with vapor-barrier mastic.
- C. Where PVC jackets are indicated, install with 1-inch overlap at longitudinal seams and end joints; for horizontal applications, install with longitudinal seams along top and bottom of tanks and vessels. Seal with manufacturer's recommended adhesive.
 1. Apply two continuous beads of adhesive to seams and joints, one bead under lap and the finish bead along seam and joint edge.
- D. Where metal jackets are indicated, install with 2-inch overlap at longitudinal seams and end joints. Overlap longitudinal seams arranged to shed water. Seal end joints with weatherproof sealant recommended by insulation manufacturer. Secure jacket with stainless-steel bands 12 inches o.c. and at end joints.

3.11 FIRE-RATED INSULATION SYSTEM INSTALLATION

- A. Where fire-rated insulation system is indicated, secure system to ducts and duct hangers and supports to maintain a continuous fire rating.
- B. Insulate duct access panels and doors to achieve same fire rating as duct.
- C. Install firestopping at penetrations through fire-rated assemblies. Fire-stop systems are specified in Division 07 Section "Penetration Firestopping."

3.12 FINISHES

- A. Duct, Equipment, and Pipe Insulation with ASJ, Glass-Cloth, or Other Paintable Jacket Material: Paint jacket with paint system identified below and as specified in Division 09 painting Sections.
 1. Flat Acrylic Finish: Two finish coats over a primer that is compatible with jacket material and finish coat paint. Add fungicidal agent to render fabric mildew proof.
 - a. Finish Coat Material: Interior, flat, latex-emulsion size.
- B. Flexible Elastomeric Thermal Insulation: After adhesive has fully cured, apply two coats of insulation manufacturer's recommended protective coating.

- C. Color: Final color as selected by Architect. Vary first and second coats to allow visual inspection of the completed Work.
- D. Do not field paint aluminum or stainless-steel jackets.

3.13 FIELD QUALITY CONTROL

- A. Testing Agency: Engage a qualified testing agency to perform tests and inspections.
- B. Perform tests and inspections.
- C. Tests and Inspections:
 - 1. Inspect ductwork, randomly selected by Engineer, by removing field-applied jacket and insulation in layers in reverse order of their installation. Extent of inspection shall be limited to three location(s) for each duct system defined in the "Duct Insulation Schedule, General" Article.
 - 2. Inspect field-insulated equipment, randomly selected by Engineer, by removing field-applied jacket and insulation in layers in reverse order of their installation. Extent of inspection shall be limited to three location(s) for each type of equipment defined in the "Equipment Insulation Schedule" Article. For large equipment, remove only a portion adequate to determine compliance.
 - 3. Inspect pipe, fittings, strainers, and valves, randomly selected by Engineer, by removing field-applied jacket and insulation in layers in reverse order of their installation. Extent of inspection shall be limited to three locations of straight pipe, three locations of threaded fittings, three locations of welded fittings, three locations of threaded strainers, three locations of welded strainers, three locations of threaded valves, and three locations of flanged valves for each pipe service defined in the "Piping Insulation Schedule, General" Article.
- D. All insulation applications will be considered defective Work if sample inspection reveals noncompliance with requirements.

3.14 DUCT INSULATION SCHEDULE, GENERAL

- A. Plenums and Ducts Requiring Insulation:
 - 1. Indoor, concealed supply and outdoor air.
 - 2. Indoor, exposed supply and outdoor air.
 - 3. Indoor, return located in the penthouse and mechanical rooms.
 - 4. Indoor, concealed exhaust between automatic damper and penetration of building exterior.
 - 5. Indoor, exposed exhaust between automatic damper and penetration of building exterior.
 - 6. Indoor, concealed, type I, commercial kitchen hood exhaust.
 - 7. Indoor, exposed, type I, commercial kitchen hood exhaust.
 - 8. Indoor, concealed oven and warewash exhaust.
 - 9. Indoor, exposed over and warewash exhaust.
 - 10. Outdoor, exposed supply and return
- B. Items Not Insulated:
 - 1. Fibrous-glass ducts.
 - 2. Metal ducts with duct liner of sufficient thickness to comply with energy code and ASHRAE/IESNA 90.1.
 - 3. Factory-insulated flexible ducts.
 - 4. Factory-insulated plenums and casings.
 - 5. Flexible connectors.

6. Vibration-control devices.
7. Factory-insulated access panels and doors.
8. Return ducts in return air plenums and shafts.

3.15 INDOOR DUCT AND PLENUM INSULATION SCHEDULE

- A. Concealed, round and flat-oval, supply-air duct insulation shall be the following:
 1. Mineral-Fiber Blanket: 1-1/2 inches (38 mm) thick and 0.75-lb/cu. ft. (12-kg/cu. m) nominal density.
- B. Concealed, round and flat-oval, return-air duct insulation (in unconditioned space) shall be the following:
 1. Mineral-Fiber Blanket: 2 inches (51 mm) thick and 0.75-lb/cu. ft. (12-kg/cu. m) nominal density.
- C. Concealed, round and flat-oval, outdoor-air duct insulation shall be the following:
 1. Mineral-Fiber Board: 2 inches (51 mm) thick and 6-lb/cu. ft. (96-kg/cu. m) nominal density.
- D. Concealed, round and flat-oval, exhaust-air duct insulation between automatic damper and penetration of building exterior shall be the following:
 1. Mineral-Fiber Blanket: 1-1/2 inches (38 mm) thick and 0.75-lb/cu. ft. (12-kg/cu. m) nominal density.
- E. Concealed, rectangular, supply-air duct insulation shall be the following:
 1. Mineral-Fiber Blanket: 1-1/2 inches (38 mm) thick and 0.75-lb/cu. ft. nominal density.
- F. Concealed, rectangular, return-air duct insulation (in unconditioned space)shall be the following:
 1. Mineral-Fiber Blanket: 2 inches (51 mm) thick and 0.75-lb/cu. ft. nominal density.
- G. Concealed, rectangular, outdoor-air duct insulation shall be the following:
 1. Mineral-Fiber Board: 2 inches (51 mm) thick and 6-lb/cu. ft. (96-kg/cu. m) nominal density
- H. Concealed, rectangular, exhaust-air duct insulation between isolation damper and penetration of building exterior shall be the following:
 1. Mineral-Fiber Board: 2 inches (51 mm) thick and 6-lb/cu. ft. (96-kg/cu. m) nominal density
- I. Concealed, Type I, Commercial, Kitchen Hood Exhaust Duct and Plenum Insulation: Fire-rated blanket or board; thickness as required to achieve 2-hour fire rating.
- J. Concealed, outdoor-air plenum insulation(in unconditioned space) shall be the following:
 1. Mineral-Fiber Board: 2 inches (51 mm) thick and 6-lb/cu. ft. (96-kg/cu. m) nominal density.
- K. Concealed, exhaust-air plenum insulation shall be the following:
 1. Mineral-Fiber Board: 2 inches (51 mm) thick and 6-lb/cu. ft. (96-kg/cu. m) nominal density.
- L. Exposed, round and flat-oval, supply-air duct insulation shall be the following:
 1. Mineral-Fiber Board: 1-1/2 inches (38 mm) thick and 6-lb/cu. ft. (96-kg/cu. m) nominal density.

- M. Exposed, round and flat-oval, return-air duct insulation in unconditioned space) shall be the following:
 - 1. Mineral-Fiber Board: 1-1/2 inches (38 mm) thick and 6-lb/cu. ft. (96-kg/cu. m) nominal density.
- N. Exposed, round and flat-oval, outdoor-air duct insulation shall be the following:
 - 1. Mineral-Fiber Board: 2 inches (51 mm) thick and 6-lb/cu. ft. (96-kg/cu. m) nominal density.
- O. Exposed, round and flat-oval, exhaust-air duct insulation shall be the following:
 - 1. Mineral-Fiber Board: 1-1/2 inches (38 mm) thick and 6-lb/cu. ft. (96-kg/cu. m) nominal density.
- P. Exposed, rectangular, supply-air duct insulation shall be the following:
 - 1. Mineral-Fiber Board: 1-1/2 inches (38 mm) thick and 6-lb/cu. ft. (96-kg/cu. m) nominal density.
- Q. Exposed, rectangular, return-air duct insulation (in unconditioned space) shall be the following:
 - 1. Mineral-Fiber Board: 1-1/2 inches (38 mm) thick and 6-lb/cu. ft. (96-kg/cu. m) nominal density.
- R. Exposed, rectangular, outdoor-air duct insulation shall be the following:
 - 1. Mineral-Fiber Board: 2 inches (51 mm) thick and 6-lb/cu. ft. (96-kg/cu. m) nominal density.
- S. Exposed, rectangular, exhaust-air duct insulation shall be the following:
 - 1. Mineral-Fiber Board: 1-1/2 inches (38 mm) thick and 6-lb/cu. ft. (96-kg/cu. m) nominal density.
- T. Exposed, Type I, Commercial, Kitchen Hood Exhaust Duct and Plenum Insulation: Fire-rated blanket or board; thickness as required to achieve 2-hour fire rating.
- U. Exposed, outdoor-air plenum insulation shall be the following:
 - 1. Mineral-Fiber Board: 2 inches (51 mm) thick and 6-lb/cu. ft. (96-kg/cu. m) nominal density.
- V. Exposed, exhaust-air plenum insulation shall be the following:
 - 1. Mineral-Fiber Board: 2 inches (51 mm) thick and 6-lb/cu. ft. (96-kg/cu. m) nominal density.

3.16 ABOVEGROUND, OUTDOOR DUCT AND PLENUM INSULATION SCHEDULE

- A. Insulation materials and thicknesses are identified below. If more than one material is listed for a duct system, selection from materials listed is Contractor's option.
- B. Exposed, round and flat-oval, supply-air duct insulation shall be the following:
 - 1. Mineral-Fiber Board: 2 inches (51 mm) thick and 6-lb/cu. ft. (96-kg/cu. m) nominal density.
- C. Exposed, round and flat-oval, return-air duct insulation shall be the following:
 - 1. Mineral-Fiber Board: 2 inches (51 mm) thick and 6-lb/cu. ft. (96-kg/cu. m) nominal density.

- D. Exposed, rectangular, supply-air duct insulation shall be the following:
 - 1. Mineral-Fiber Board: 2 inches (51 mm) thick and 6-lb/cu. ft. (96-kg/cu. m) nominal density.
- E. Exposed, rectangular, return-air duct insulation shall be the following:
 - 1. Mineral-Fiber Board: 2 inches (51 mm) thick and 6-lb/cu. ft. (96-kg/cu. m) nominal density.
- F. Exposed, supply-air plenum insulation shall be the following:
 - 1. Mineral-Fiber Board: 2 inches (51 mm) thick and 6-lb/cu. ft. (96-kg/cu. m) nominal density.
- G. Exposed, return-air plenum insulation shall be the following:
 - 1. Mineral-Fiber Board: 2 inches (51 mm) thick and 6-lb/cu. ft. (96-kg/cu. m) nominal density.

3.17 EQUIPMENT INSULATION SCHEDULE

- A. Insulation materials and thicknesses are identified below.
- B. Insulate indoor and outdoor equipment in paragraphs below that is not factory insulated.
- C. Chilled-water pumps insulation shall be the following:
 - 1. Mineral-Fiber Board: 2 inches thick and 6-lb/cu. ft. nominal density.
- D. Heating-hot-water pump insulation shall be the following:
 - 1. Mineral-Fiber Board: 2 inches (50 mm) thick and 6-lb/cu. ft. (96-kg/cu. m) nominal density.
- E. Heating-hot-water and chilled water air-separator insulation shall be the following:
 - 1. Mineral-Fiber Board: 2 inches thick and 6-lb/cu. ft. nominal density.

3.18 PIPING INSULATION SCHEDULE, GENERAL

- A. Acceptable preformed pipe and tubular insulation materials and thicknesses are identified for each piping system and pipe size range. If more than one material is listed for a piping system, selection from materials listed is Contractor's option.
- B. Items Not Insulated: Unless otherwise indicated, do not install insulation on the following:
 - 1. Drainage piping located in crawl spaces.
 - 2. Chrome-plated pipes and fittings unless there is a potential for personnel injury.

3.19 INDOOR PIPING INSULATION SCHEDULE

- A. Cold water Makeup, condensate and Equipment Drain Water below 60 Deg F:
 - 1. All Pipe Sizes: Insulation shall be the following:
 - a. Mineral Fiber Preformed pipe type I: 1 inch thick
- B. Chilled Water Supply and Return, 40 Deg F
 - 1. NPS 3 and smaller: Insulation shall be the following:
 - a. Mineral Fiber Preformed pipe type I : 1 inch thick

2. NPS 4 TO NPS 12 : Insulation shall be the following:
 - a. Mineral Fiber Preformed pipe insulation type 1: 1-1/2 inch thick
 3. NPS 14 and larger: Insulation to be the followings;
 - a. Mineral Fiber Preformed pipe insulation type 1: 1-1/2 inch thick
 - C. Heating-Hot-Water Supply and Return, 200 Deg F and below:
 1. NPS 12 inches and Smaller: Insulation shall be the following:
 - a. Mineral-Fiber, Preformed Pipe, Type I: 1 ½ inches thick.
 - D. Refrigerant Suction and Hot-Gas Piping:
 1. All Pipe Sizes: Insulation shall be the following:
 - a. Flexible Elastomeric: 1 inch thick.
 - E. Hot Service Drains:
 1. All Pipe Sizes: Insulation shall be the following:
 - a. Mineral-Fiber, Preformed Pipe, Type I or II: 1 inch thick.
 - F. Hot Service Vents:
 1. All Pipe Sizes: Insulation shall be the following:
 - a. Mineral-Fiber, Preformed Pipe, Type I or II: 1 inch thick.
 - G. Steam and Steam Condensate, 350 Deg F (177 Deg C) and below:
 1. NPS ¾ inches and Smaller: Insulation shall be the following:
 - a. Mineral-Fiber, Preformed Pipe, Type I or II: 2 inches (50 mm) thick.
 2. NPS 1 inch to 6 inch: Insulation shall be the following:
 - a. Mineral- Fiber, Performed Pipe, Type I or II: 3 inches (75 mm) thick.
 3. NPS 8 inch and Larger: Insulation shall be the following:
 - a. Mineral-Fiber, Preformed Pipe, Type I or II: 4 inches (100 mm) thick.
 - H. Steam and Steam Condensate, above 350 Deg F (177 Deg C):
 1. NPS ¾ inches and Smaller: Insulation shall be the following:
 - a. Mineral-Fiber, Preformed Pipe, Type I or II: 2 inches (50 mm) thick.
 2. NPS 1 inch and Larger: Insulation shall be the following:
 - a. Mineral- Fiber, Preformed Pipe, Type I or II: 3 inches (75 mm) thick.
- 3.20 OUTDOOR, ABOVEGROUND AND UNHEATED ENCLOSURE PIPING INSULATION SCHEDULE
- A. Piping that is exposed to outside elements or below building ambient temperatures shall be heat traced and insulated. Coordinate all requirements with electrical contractor for piping lengths. All piping insulation installed outdoors or exposed above ground shall be protected by a wrapped weather proof all aluminum heavy duty jacket (.050" thick) with z-shaped locking seams.
 - B. Cold water Makeup and Equipment Drain Water:
 1. All Pipe Sizes: Insulation shall be the following:
 - a. Mineral Fiber Preformed pipe type I: 1-1/2 inch thick
 - b. Allow for heat traced piping surfaces
 - C. Chilled Water Supply and Return:
 1. All Pipe Sizes: Insulation shall be the following:
 - a. Mineral-Fiber, Preformed Pipe Insulation, Type I: 3 inches (75 mm) thick.
 - D. Heating-Hot-Water Supply and Return, 200 Deg F and below:
 1. All Pipe Sizes: Insulation shall be the following:
 - a. Mineral-Fiber, Preformed Pipe Insulation, Type I or II: 1 ½ inches (50 mm) thick.

- b. Allow for heat traced piping surfaces.
- E. Refrigerant Suction and Hot-Gas Piping:
- 1. All Pipe Sizes: Insulation shall be the following:
 - a. Flexible Elastomeric: 2 inches thick.
- 3.21 INDOOR, FIELD-APPLIED JACKET SCHEDULE
- A. Install jacket over insulation material. For insulation with factory-applied jacket, install the field-applied jacket over the factory-applied jacket.
 - B. Ducts and Plenums, Concealed:
 - 1. None.
 - C. Ducts and Plenums, Exposed:
 - 1. None.
 - D. Equipment, Concealed:
 - 1. None.
 - E. Equipment, Exposed, up to 48 Inches in Diameter or with Flat Surfaces up to 72 Inches:
 - 1. None.
 - F. Equipment, Exposed, Larger Than 48 Inches in Diameter or with Flat Surfaces Larger Than 72 Inches:
 - 1. None.
 - G. Piping, Concealed:
 - 1. None.
 - H. Piping, exposed:
 - 1. PVC Jackets in Mechanical rooms up to 10 feet AFF and on all exposed piping in occupied spaces.
 - I. Piping, Fittings and Elbows:
 - 1. PVC fitting Jackets on all pipe fittings, elbows, valves, tees and mechanical couplings.
 - 2. Extended valve stems shall be fitted with PVC jackets and insulation.
 - 3. Provide continuous vapor barrier on all cold surfaces.
- 3.22 OUTDOOR, FIELD-APPLIED JACKET SCHEDULE
- A. Install jacket over insulation material. For insulation with factory-applied jacket, install the field-applied jacket over the factory-applied jacket.
 - B. If more than one material is listed, selection from materials listed is Contractor's option.
 - C. Ducts and Plenums, Exposed, up to 48 Inches (1200 mm) in Diameter or with Flat Surfaces up to 72 Inches (1800 mm):
 - 1. Aluminum, Smooth: 0.024 inch (0.61 mm) thick.
 - 2. Self-adhesive Aluminized Outdoor Jacket, White, stucco-embossed, 40 mil (1.00 mm).
 - D. Ducts and Plenums, Exposed, Larger Than 48 Inches (1200 mm) in Diameter or with Flat Surfaces Larger Than 72 Inches (1800 mm):

1. Painted Aluminum, Smooth with 2-1/2-Inch- (65-mm-) Deep Corrugations 4-by-1-Inch (100-by-25-mm) Box Ribs: 0.040 inch (1.0 mm) thick.
- E. Piping, Exposed:
1. Painted Aluminum, Smooth Corrugated with Z-Shaped Locking Seam: 0.020 inch (0.51 mm) 0.024 inch (0.61 mm) thick.

END OF SECTION

SECTION 23 08 00

COMMISSIONING OF HVAC

PART 1 - GENERAL

1.1 RELATED DOCUMENTS

- A. Drawings and general provisions of the Contract, including General and Supplementary Conditions and other Division 01 Specification Sections, apply to this Section.
- B. Section 01 81 13 "Sustainable Design Requirements – LEED v4 for Building Design & Construction – New Construction" for sustainable design requirements and detailed sustainable design submittal requirements.
- C. Section 01 74 19 "Construction and Demolition Waste Management and Disposal" for disposal of construction, demolition and packaging waste disposal requirements.

1.2 SUMMARY

- A. Section includes commissioning process requirements for HVAC&R systems, assemblies, and equipment.
- B. Related Sections:
 - 1. Division 01 9100 Section "General Commissioning Requirements" for general commissioning process requirements.
- C. Sustainable Building Requirements:
 - 1. The Owner requires the Contractor to implement practices and procedures to meet the project's environmental performance goals, which include achieving LEED version 4 **Certified** level Certification. Specific project goals that may impact this area of work include: use of recycled-content materials; use of locally-manufactured materials; use of low-emitting materials; construction waste recycling; and the implementation of a construction indoor air quality management plan. The Contractor shall ensure that the requirements related to these goals, as defined in the Articles below, are implemented to the fullest extent. Substitutions, or other changes to the work proposed by the Contractor or their Subcontractors, shall not be allowed if such changes compromise the aforementioned environmental goals and LEED certification.

1.3 ALLOWANCES

- A. Labor, instrumentation, tools, and equipment costs for technicians for the performance of commissioning testing are covered by the "Schedule of Allowances" Article in Division 01 Section "Allowances."

1.4 UNIT PRICES

- A. Commissioning testing allowance may be adjusted up or down by the "List of Unit Prices" Article in Division 01 Section "Unit Prices" when actual man-hours are computed at the end of commissioning testing.

1.5 CONTRACTOR'S RESPONSIBILITIES

- A. Perform commissioning tests at the direction of the CxA.
- B. Attend construction phase controls coordination meeting.
- C. Attend testing, adjusting, and balancing review and coordination meeting.
- D. Participate in HVAC&R systems, assemblies, equipment, and component maintenance orientation and inspection as directed by the CxA.
- E. Provide information requested by the CxA for final commissioning documentation.
- F. Provide measuring instruments and logging devices to record test data, and provide data acquisition equipment to record data for the complete range of testing for the required test period.

1.6 CxA'S RESPONSIBILITIES

- A. Provide Project-specific construction checklists and commissioning process test procedures for actual HVAC&R systems, assemblies, equipment, and components to be furnished and installed as part of the construction contract.
- B. Direct commissioning testing.
- C. Verify testing, adjusting, and balancing of Work are complete.
- D. Provide test data, inspection reports, and certificates in Systems Manual.

1.7 COMMISSIONING DOCUMENTATION

- A. Provide the following information to the CxA for inclusion in the commissioning plan:
 - 1. Plan for delivery and review of submittals, systems manuals, and other documents and reports.
 - 2. Identification of installed systems, assemblies, equipment, and components including design changes that occurred during the construction phase.
 - 3. Process and schedule for completing construction checklists and manufacturer's prestart and startup checklists for HVAC&R systems, assemblies, equipment, and components to be verified and tested.
 - 4. Certificate of completion certifying that installation, prestart checks, and startup procedures have been completed.
 - 5. Certificate of readiness certifying that HVAC&R systems, subsystems, equipment, and associated controls are ready for testing.
 - 6. Test and inspection reports and certificates.
 - 7. Corrective action documents.
 - 8. Verification of testing, adjusting, and balancing reports.

1.8 SUBMITTALS

- A. Certificates of readiness.

- B. Certificates of completion of installation, prestart, and startup activities.

PART 2 - PRODUCTS

(Not Used)

PART 3 - EXECUTION

3.1 TESTING PREPARATION

- A. Certify that HVAC&R systems, subsystems, and equipment have been installed, calibrated, and started and are operating according to the Contract Documents.
- B. Certify that HVAC&R instrumentation and control systems have been completed and calibrated, that they are operating according to the Contract Documents, and that pretest set points have been recorded.
- C. Certify that testing, adjusting, and balancing procedures have been completed and that testing, adjusting, and balancing reports have been submitted, discrepancies corrected, and corrective work approved.
- D. Set systems, subsystems, and equipment into operating mode to be tested (e.g., normal shutdown, normal auto position, normal manual position, unoccupied cycle, emergency power, and alarm conditions).
- E. Inspect and verify the position of each device and interlock identified on checklists.
- F. Check safety cutouts, alarms, and interlocks with smoke control and life-safety systems during each mode of operation.
- G. Testing Instrumentation: Install measuring instruments and logging devices to record test data as directed by the CxA.

3.2 TESTING AND BALANCING VERIFICATION

- A. Prior to performance of testing and balancing Work, provide copies of reports, sample forms, checklists, and certificates to the CxA.
- B. Notify the CxA at least [10] <Insert number> days in advance of testing and balancing Work, and provide access for the CxA to witness testing and balancing Work.
- C. Provide technicians, instrumentation, and tools to verify testing and balancing of HVAC&R systems at the direction of the CxA.
 - 1. The CxA will notify testing and balancing [Contractor] [Subcontractor] [10] <Insert number> days in advance of the date of field verification. Notice will not include data points to be verified.
 - 2. The testing and balancing [Contractor] [Subcontractor] shall use the same instruments (by model and serial number) that were used when original data were collected.
 - 3. Failure of an item includes, other than sound, a deviation of more than 10 percent. Failure of more than 10 percent of selected items shall result in rejection of final testing, adjusting, and balancing report. For sound pressure readings, a deviation of 3 dB shall result in rejection of final testing. Variations in background noise must be considered.

4. Remedy the deficiency and notify the CxA so verification of failed portions can be performed.

3.3 GENERAL TESTING REQUIREMENTS

- A. Provide technicians, instrumentation, and tools to perform commissioning test at the direction of the CxA.
- B. Scope of HVAC&R testing shall include entire HVAC&R installation, from central equipment for heat generation and refrigeration through distribution systems to each conditioned space. Testing shall include measuring capacities and effectiveness of operational and control functions.
- C. Test all operating modes, interlocks, control responses, and responses to abnormal or emergency conditions, and verify proper response of building automation system controllers and sensors.
- D. The CxA along with the HVAC&R [**Contractor**] [**Subcontractor**], testing and balancing [**Contractor**] [**Subcontractor**], and HVAC&R Instrumentation and Control [**Contractor**] [**Subcontractor**] shall prepare detailed testing plans, procedures, and checklists for HVAC&R systems, subsystems, and equipment.
- E. Tests will be performed using design conditions whenever possible.
- F. Simulated conditions may need to be imposed using an artificial load when it is not practical to test under design conditions. Before simulating conditions, calibrate testing instruments. Provide equipment to simulate loads. Set simulated conditions as directed by the CxA and document simulated conditions and methods of simulation. After tests, return settings to normal operating conditions.
- G. The CxA may direct that set points be altered when simulating conditions is not practical.
- H. The CxA may direct that sensor values be altered with a signal generator when design or simulating conditions and altering set points are not practical.
- I. If tests cannot be completed because of a deficiency outside the scope of the HVAC&R system, document the deficiency and report it to the Owner. After deficiencies are resolved, reschedule tests.
- J. If the testing plan indicates specific seasonal testing, complete appropriate initial performance tests and documentation and schedule seasonal tests.

3.4 HVAC&R SYSTEMS, SUBSYSTEMS, AND EQUIPMENT TESTING PROCEDURES

- A. Boiler Testing and Acceptance Procedures: Testing requirements are specified in Division 23 boiler Sections. Provide submittals, test data, inspector record, and boiler certification to the CxA.
- B. HVAC&R Instrumentation and Control System Testing: Field testing plans and testing requirements are specified in Division 23 Sections "Instrumentation and Control for HVAC" and "Sequence of Operations for HVAC Controls." Assist the CxA with preparation of testing plans.
- C. Pipe system cleaning, flushing, hydrostatic tests, and chemical treatment requirements are specified in Division 23 piping Sections. HVAC&R [**Contractor**] [**Subcontractor**] shall prepare a pipe system cleaning, flushing, and hydrostatic

testing plan. Provide cleaning, flushing, testing, and treating plan and final reports to the CxA. Plan shall include the following:

1. Sequence of testing and testing procedures for each section of pipe to be tested, identified by pipe zone or sector identification marker. Markers shall be keyed to Drawings for each pipe sector, showing the physical location of each designated pipe test section. Drawings keyed to pipe zones or sectors shall be formatted to allow each section of piping to be physically located and identified when referred to in pipe system cleaning, flushing, hydrostatic testing, and chemical treatment plan.
 2. Description of equipment for flushing operations.
 3. Minimum flushing water velocity.
 4. Tracking checklist for managing and ensuring that all pipe sections have been cleaned, flushed, hydrostatically tested, and chemically treated.
- D. Energy Supply System Testing: Provide technicians, instrumentation, tools, and equipment to test performance of [oil] [gas] [coal] [steam] [hot-water] [and] [solar] systems and equipment at the direction of the CxA. The CxA shall determine the sequence of testing and testing procedures for each equipment item and pipe section to be tested.
- E. Refrigeration System Testing: Provide technicians, instrumentation, tools, and equipment to test performance of chillers, cooling towers, refrigerant compressors and condensers, heat pumps, and other refrigeration systems. The CxA shall determine the sequence of testing and testing procedures for each equipment item and pipe section to be tested.
- F. HVAC&R Distribution System Testing: Provide technicians, instrumentation, tools, and equipment to test performance of air, steam, and hydronic distribution systems; special exhaust; and other distribution systems, including HVAC&R terminal equipment and unitary equipment.
- G. Vibration and Sound Tests: Provide technicians, instrumentation, tools, and equipment to test performance of vibration isolation and seismic controls.
- H. <Insert HVAC systems>.

END OF SECTION

This page is intentionally left blank.

SECTION 230900

HVAC INSTRUMENTATION AND CONTROLS

PART 1 - GENERAL

1.1 RELATED DOCUMENTS

- A. Drawings and general provisions of the Contract, including General and Supplementary Conditions and Division 1 Specification Sections, apply to this section.
- B. Section 01 81 13 "Sustainable Design Requirements – LEED v4 for Building Design & Construction – New Construction" for sustainable design requirements and detailed sustainable design submittal requirements.
- C. Section 01 74 19 "Construction and Demolition Waste Management and Disposal" for disposal of construction, demolition and packaging waste disposal requirements

1.2 SUMMARY

- A. This Section includes control equipment for HVAC systems and components, including control components for terminal heating and cooling units not supplied with factory-wired controls.
- B. Sustainable Building Requirements:
 - 1. The Owner requires the Contractor to implement practices and procedures to meet the project's environmental performance goals, which include achieving LEED version 4 Certified level Certification. Specific project goals that may impact this area of work include: use of recycled-content materials; use of locally-manufactured materials; use of low-emitting materials; construction waste recycling; and the implementation of a construction indoor air quality management plan. The Contractor shall ensure that the requirements related to these goals, as defined in the Articles below, are implemented to the fullest extent. Substitutions, or other changes to the work proposed by the Contractor or their Subcontractors, shall not be allowed if such changes compromise the aforementioned environmental goals and LEED certification.

1.3 DEFINITIONS

- A. AHU: Air Handling Unit.
- B. ATC: Automatic Temperature Control.
- C. BMS: Building Management System.
- D. CFM: Cubic Feet per Minute.
- E. DDC: Direct-digital controls.
- F. FAS: Fire Alarm System.

- G. HVAC: Heating, Ventilating and Air Conditioning.
- H. LAN: Local area network.
- I. LCD: Liquid Crystal Display
- J. MER: Mechanical Equipment Room.
- K. PID: Proportional Integral Derivative.
- L. POT: Portable Operators Terminal.
- M. VFD: Variable Frequency Drive.

1.4 SYSTEM DESCRIPTION

- A. Control system consists of sensors, indicators, actuators, final control elements, interface equipment, other apparatus and accessories to control mechanical systems.
- B. Control system shall consist of sensors, indicators, actuators, final control elements, interface equipment, other apparatus, accessories and software connected to distributed controllers operating in multiuser, multitasking environment on a network and programmed to control mechanical systems. An operator workstation permits interface with the network via dynamic color graphics with each mechanical system, building floor plan and control device depicted by point-and-click graphics.
- C. Furnish a totally BACnet-based system, based on a distributed control system in accordance with this specification. The operator's workstation, all controllers and all input/output devices shall communicate using the protocols and network standards as defined by ANSI/ASHRAE Standard 135 - 2010 - BACnet. In other words, all workstations and controllers shall be BACnet devices. No gateways shall be used for communication to controllers installed under this section. Gateways may be used for communication to existing systems or to systems installed under other sections. Use of proprietary protocol on any part of the network is prohibited.
- D. Provide Building Controllers (BC), Advanced Application Controllers (AAC), Application Specific Controllers (ASC), Smart Actuators (SA) and Smart Sensors (SS) as required. Every device in the system which executes control logic and directly controls HVAC equipment must conform to a standard BACnet Device profile as specified in the latest version of ANSI/ASHRAE 135, BACnet Annex L. Unless otherwise specified, hardwired actuators and sensors may be used in lieu of BACnet Smart Actuators and Smart Sensors.

1.5 SYSTEM PERFORMANCE

- A. Comply with the following performance requirements:
- B. Graphic Display: Display graphic with minimum 20 dynamic points with current data within 10 seconds.
 - 1. Graphic Refresh: Update graphic with minimum 20 dynamic points with current data within 8 seconds.

2. Object Command: Reaction time of less than 2 seconds between operator command of a binary object and device reaction.
3. Object Scan: Transmit change of state and change of analog values to control units or workstation within 6 seconds.
4. Alarm Response Time: Annunciate alarm at workstation within 45 seconds. Multiple workstations must receive alarms within 5 seconds of each other.

1.6 WORK INCLUDED

- A. Furnish a complete distributed direct digital control system in accordance with this specification section. This includes all supervisory controllers, network controllers, logic controllers and all input/output devices. Items of work included are as follows:
 1. Provide a submittal that meets the requirements below for approval.
 2. Coordinate installation schedule with the mechanical contractor and general contractor.
 3. Provide installation of all panels and devices unless otherwise stated.
 4. Provide power for panels and control devices from a source designated by the electrical contractor. All 120 volt power circuits to the DDC panel(s) shall be provided by this Contractor (unless specifically shown on the electrical drawings).
 5. Provide all low voltage control wiring for the DDC system. All wiring of sensors and control devices including any power wiring of devices and necessary conduit shall be provided under this section of the specifications.
 6. Provide miscellaneous control wiring for HVAC and related systems regardless of voltage.
 7. Provide engineering and technician labor to program and commission software for each system and operator interface. Submit start up reports for approval.
 8. Provide testing, demonstration and training as specified below.
 9. Provide all necessary BACnet-compliant hardware and software to meet the system's functional specifications. Provide Protocol Implementation Conformance Statement (PICS) for Windows-based control software and every controller in system.
 10. The BMS server licensing options shall allow a minimum of five (5) local workstation connections/access concurrently.
 11. The web server licensing options shall allow concurrent access by a minimum of five (5) remote browser connections. These licenses shall be in addition to the five (5) licenses assigned for local connections
 12. BMS controllers must be powered off the equipment branch. Applies to all central equipment (AHUs, pumps, condensate pumps, etc.) and any fan

serving isolation rooms, protective environment rooms or any other space that must maintain a pressure relationship to its surroundings.

13. BMS controllers shall be connected to UPS power. Installation shall incorporate a bypass switch to allow for a faulty UPS to be replaced without interrupting power to the controller or controllers it serves.

1.7 SUBMITTALS

- A. One (1) submittal package shall be provided for the project that includes information for controls for all systems being provided as part of the project. Partial submittals are not acceptable and shall not be reviewed by the Engineer. For example, it is not acceptable to submit a control valve schedule as part of one package and control diagrams as part of a later package. For large projects or where partial submittals may be required to maintain the project schedule, the contractor shall coordinate a schedule for delivery of each partial submittal and the items to be contained within each submittal. It shall not be up to the contractor's discretion as to what shall be included in each partial submittal.
- B. Product Data: Include manufacturer's technical literature for each control device. Indicate dimensions, capacities, performance characteristics, electrical characteristics, finishes for materials and installation and startup instructions for each type of product indicated.
 1. Each control device labeled with setting or adjustable range of control.
 2. DDC System Hardware: Include technical data for operator workstation equipment, interface equipment, control units, transducers/transmitters, sensors, actuators, valves, relays/switches, control panels and operator interface equipment.
 3. Control System Software: Include technical data for operating system software, operator interface, color graphics and other third-party applications.
 4. Controlled Systems: Instrumentation list with element name, type of device, manufacturer, model number and product data. Include written description of sequence of operation including schematic diagram.
- C. Shop Drawings: Detail equipment assemblies and indicate dimensions, weights, loads, required clearances, method of field assembly, components and location and size of each field connection. Submittal shall include the following as a minimum:
 1. Schematic flow diagrams showing fans, pumps, coils, dampers, valves, instrumentation and control devices.
 2. Wiring Diagrams: Power, signal and control wiring.
 3. Architecture drawing including all communication wiring, network devices, etc. Indicate type of cabling and number of conductors.
 4. Symbol and abbreviation list for control diagrams.
 5. Points list including hardwired and software points.

6. Manufacturer's technical cut sheets which include a table of contents and an associated sheet numbering system for all pages. Model number shall be circled or pointed with an arrow.
 7. A complete bill of materials specific to each system detailing the equipment to be used, quantity, manufacturer, specific model number and tag number.
 8. List of color graphics indicating monitored systems, data (connected and calculated) point addresses, output schedule and operator notations.
 9. Details of control panel faces, including controls, instruments and labeling.
 10. Schedule of dampers including size, leakage and flow characteristics.
 11. Schedule of valves including leakage, flow characteristics, GPM, design pressure drop, actual pressure drop, design CV, calculated CV, valve body pressure rating, and close-off pressure rating at a minimum.
 12. All shop drawings used by field personnel for the installation of equipment shall bear an Engineer's approval stamp.
 13. Architectural floor plans indicating proposed locations of all wall-mounted devices (i.e., DDC units, control panels, sensors, thermostats, etc.) and mechanical drawings indicating proposed locations of all temperature, flow and pressure transmitters.
 14. Qualification Data: For firms and persons specified in "Quality Assurance" Article.
- D. Data Communications Protocol Certificates: Certify that each proposed DDC system component complies with the latest version of ASHRAE 135 related to BACnet.
- E. Samples for Initial Selection: For each color required, of each type of thermostat and/or sensor cover with factory-applied color finishes.
- F. Operation and Maintenance Data: For HVAC instrumentation and control system to include in emergency, operation and maintenance manuals. In addition to items specified in Division 1 Section "Operation and Maintenance Data," include the following:
1. Maintenance instructions and lists of spare parts for each type of control device and compressed-air station.
 2. Inspection period, cleaning methods, cleaning materials recommended and calibration tolerances.
 3. Calibration records and list of set points.
- G. The BMS Contractor shall correct any errors or omissions noted by the Owner and Engineer during review.
- H. Device substitutions shall be considered as long as they are submitted to the engineer one week in advance of the bid via a formal RFI. Contractor shall provide a technical comparison in spreadsheet format that includes, at a minimum,

comparison of physical size, accuracy, drift, cost, turndown, options provided, device warranty, as applicable.

1.8 SEQUENCING AND SCHEDULING

- A. Sequence and coordinate the work of this Section with the scheduling requirements and the Engineer. Review the approved schedule with the Engineer, sub-contractors, manufacturers, vendors, suppliers and all other contractors. Schedule and sequence all Work with the adjoining Work, and Work of others such that the all Work can be accomplished concurrently during the same time period.

1.9 QUALITY ASSURANCE

- A. Installer Qualifications: A qualified installer who is an authorized representative of the automatic control system manufacturer for both installation and maintenance of units required for this Project.
- B. Electrical Components, Devices and Accessories: Listed and labeled as defined in NFPA 70, Article 100, by a testing agency acceptable to authorities having jurisdiction and marked for intended use.
- C. Comply with NFPA 90A, "Installation of Air Conditioning and Ventilation Systems."
- D. Materials and equipment shall be the catalogued products of manufacturers regularly engaged in production and installation of automatic temperature control systems and shall be manufacturer's latest standard design that complies with the specification requirements.
- E. All portions of the system must be designed, furnished, installed, commissioned and serviced by manufacturer-approved, factory-trained employees.
- F. Single source responsibility of supplier shall be the complete installation and proper operation of the BMS and control system and shall include debugging and proper calibration of each component in the entire system.
- G. Supplier shall have an in-place support facility within 50 miles of the site with technical staff, spare parts inventory and all necessary test and diagnostic equipment.
- H. All electronic equipment shall conform to the requirements of FCC Regulation, Part 15, Section 15, Governing Radio Frequency Electromagnetic Interference and be so labeled.
- I. BMS shall comply with UL 916 PAZX and 864 UDTZ and be so listed at the time of bid.
- J. System devices shall have UL 864 (UUKL smoke control) and shall be so certified at time of bid, if the system is being used for smoke control or life safety
- K. All system components shall be fault-tolerant. System shall include:
 - 1. Satisfactory operation without damage at 110% and 90% of rated voltage and at plus 3 Hertz variation in line frequency.
 - 2. Static, transient and short-circuit protection on all inputs and outputs.

3. Protection for communication lines against incorrect wiring, static transients and induced magnetic interference.
 4. Network-connected devices to be AC coupled or equivalent so that any single device failure will not disrupt or halt network communication.
 5. All real time clocks and data file RAM to be battery-backed for a minimum 100 hours and include local and remote system low battery indication.
- L. The BMS contractor shall be regularly engaged in the installation and maintenance of BMS systems and shall meet the following qualifications.
1. A minimum of 10 years of demonstrated technical expertise and experience in the installation and maintenance of BMS systems similar in size and complexity to this project.
 2. A minimum of 10 years experience installing the control system of the manufacturer that is to be proposed.
 3. Shall be a certified-to-install, direct representative of a control system manufacturer that has a minimum of 10 years experience producing control systems similar to that which is to be proposed.
 4. A maintained service organization consisting of at least 8 competent servicemen, within 50 miles of the project site, for a period of not less than 10 years.
 5. The Bidder shall not be considered qualified to bid this project unless they can provide a list of 10 projects, similar in size and scope to this project, completed within the last 4 years.
 6. The system manufacturer/installer shall provide an experienced project manager for this work from beginning of control installation until final completion. The project manager is responsible for direct supervision of the design, installation, start-up and commissioning of the BMS as well as attending of project meetings whenever directed by the owner, construction manager and/or mechanical contractor. It shall not be acceptable to change the project manager after the project has begun and before final completion. If the BMS manufacturer wishes to change the project manager, the construction manager and/or owner's representative must be notified immediately and both the new project manager and the previous project manager shall spend three (3) consecutive business days together on-site performing a project management switchover. Exceptions may be allowed for small projects as determined by the construction manager and/or owner's representative.
- M. Comply with all current governing codes, ordinances and regulations including UL, NFPA, the local Building Code, NEC, etc.
- N. The system shall have a documented history of compatibility by design for a minimum of 15 years. Future compatibility shall be supported for no less than 10 years. Compatibility shall be defined as the ability for any existing control system component including but not limited to primary control panels, secondary control panels, personal operator workstations and portable operator's terminals, to be

connected and directly communicate with any new BMS system equipment without bridges, routers or protocol converters.

1.10 DELIVERY, STORAGE AND HANDLING

- A. Factory-Mounted Components: Where control devices specified in this Section are indicated to be factory mounted on equipment, arrange for shipping of control devices to unit manufacturer.
- B. Provide factory shipping cartons for each piece of equipment and control device. Maintain cartons while shipping, storing and handling as required to prevent equipment damage, and to eliminate dirt and moisture from equipment. Store equipment and materials inside and protect from weather. The stored products shall be protected from the weather, humidity and temperature variations, dirt and dust, and other contaminants, within the storage condition limits published by the equipment manufacturer.
- C. System Software: Update to latest version of software at project completion.

1.11 COORDINATION

- A. Coordinate location of temperature sensors, humidity sensors and other exposed control sensors with plans and room details before installation.
- B. Coordinate installation of taps, valves, airflow stations, etc. with the mechanical contractor.
- C. Coordinate BMS equipment with all relevant divisions including, but not limited to, Fire Alarm to achieve compatibility with equipment that interfaces with that system.
- D. Coordinate BMS equipment to achieve compatibility with motor starters and annunciation devices.

1.12 EXTRA MATERIALS

- A. Maintenance Materials: One (1) thermostat adjusting key.

PART 2 - PRODUCTS

2.1 MANUFACTURERS

- A. Available Manufacturers: Subject to compliance with requirements, manufacturers offering products that may be incorporated into the Work include the following:
 - 1. Honeywell, Inc.

2.2 CONTROL PANELS

- A. Fully enclosed, steel-rack-type cabinet with locking doors or locking removable backs. Match finish of panels and provide laminated as-built wiring diagrams, flow diagrams, etc. related to the system being controlled inside the associated cabinet. Each control panel shall be clearly and permanently labeled with the controller designation and indication of the mechanical equipment served.

- B. Where applicable, existing primary control panel enclosures shall be reused where possible. Replacement of any control panel enclosure and sub-panel shall be included in the base contract.
- C. Unitize cabinet with suitable brackets for wall or floor mounting, located adjacent to each system under automatic control. Provide common keying for all panels.
 - 1. Fabricate panels of furniture-quality steel or extruded-aluminum alloy, totally enclosed, with hinged doors and keyed lock and with manufacturer's standard shop-painted finish. All panels shall have common keying.
 - 2. Primary control panel: Provide minimum NEMA 12 rating for indoor application and NEMA 4 rating for outdoor application or the appropriate NEMA rating for application. Electrical piping and wiring shall be penetrated through the bottom of the panel with 4 inch nipples and 4 inches wiring trough. All control panel conduit penetrations shall be done at the side or the bottom of the panel as per MMC standards.
 - 3. Secondary control panel: Provide minimum NEMA 1 rating for indoor application.
 - 4. Size control panel enclosures for twenty percent spare mounting capacity for future expansion.
 - 5. Only one controller shall be allowed in a control panel with expansion modules if extra points are needed. The BMS contractor shall utilize the largest controller available and if maxed out, only then can a second controller be installed within the panel.
- D. Control panel shop drawings shall be submitted for each system (air handling unit, chilled water system, hot water system, etc.) for approval prior to fabrication.
- E. Coordinate installation of the control panels with the engineer/architect. Coordinate power for the panels with the electrical contractor.
- F. Control Panel Internal Components:
 - 1. Provide identification sleeves at each termination at the terminal strip.
 - 2. All control panels shall be provided with DIN Rail mounted screw terminal blocks. Field wiring shall be connected to the screw terminal blocks. It is not acceptable to terminate any field wiring directly to the DDC controller or any panel devices such as relay and transducers. The screw terminal blocks located/attached to the DDC controller alone does not comply with this requirement. Terminal blocks shall be rated for 300 volts, medium duty. Provide Phoenix Feed-through terminal block UT 2,5 or pre-approved equal.
 - 3. All control devices such as relays, transformers, transducers, power supplies, associated I/O devices, etc shall be installed inside the panel, not at the starter or electrical junction box.
 - 4. All panel wirings shall in be installed in Panduit and wiring duct. This shall include but not be limited to wiring from the DDC controller to the terminal

block, between DDC controller and relay (and other panel mounted control devices), power wiring for the controller, communication, etc.

5. Mounting any control devices on the back of the control panel enclosure door is not acceptable.
 6. The use of wire nuts in the control panel enclosures is also prohibited.
- G. Power wiring and communication wiring shall be provided in separate conduits with separate hot, neutral, and ground wire runs and separate breakers.
- H. Coordinate installation of the control panels with the Owner. Coordinate power for the panels with the electrical contractor.

2.3 BMS SYSTEM ARCHITECTURE

- A. The BMS system shall use a Client/Server architecture based on a modular PC network, utilizing industry standard operating systems, networks and protocols.
- B. The system shall allow the distribution of system functions such as monitoring and control and graphical user interface etc. across the network to achieve maximum flexibility and performance.
- C. Data communications protocol shall be BACnet and shall comply with the latest version of ASHRAE 135.
- D. The BMS shall utilize the building LAN (MMC IT backbone) as the primary network. Ethernet drops shall be provided by others as required. Coordinate exact locations of all Ethernet drops. The BMS contractor is responsible for all other wiring, devices, etc. required to connect to the LAN. The BMS contractor shall coordinate with MMC IT for all network tie-in requirements.

2.4 UNINTERRUPTIBLE POWER SUPPLY

- A. An Uninterruptible Power Supply (UPS) shall be provided and installed by the Contractor for each of the following devices that are powered by the BMS including; BMS primary control panels and BMS secondary control panels. Each UPS shall power the device for a minimum of 30 minutes, in the case of power interruption.
- B. Each UPS shall be DIN-Rail mounted in control cabinets for all new HVAC controllers. All control cabinets shall be properly labeled with the unit served.
- C. The UPS shall consist of a battery power source, charger, AC output inverter system and automatic load transfer circuits for a full automatic operation. The UPS shall be an on-line type. When normal AC power returns, the UPS shall transfer the load to the rectifier output. At this time, the charger shall turn on to its 'high' charge rate until the batteries are charged approximately 80% of their rated capacity and then automatically shall switch to its maintenance 'sensing' position to keep the batteries in their best full-charge condition. Battery recharge time shall not be more than 3 hours.
- D. Each UPS shall be provided, as a minimum, with pilot lights for the following conditions: "Incoming AC Power is Available", "UPS Ready Mode" and "UPS in Standby Mode". The UPS shall have the capability to hot-swap batteries without interrupting the supply of power to its users.

E. The batteries shall be of the totally enclosed nickel-cadmium type or equal. Batteries that can leak gas shall not be acceptable. There shall not be any damages should the emergency outage of line power exceed the maximum operation time of the UPS. Automatic shutdown shall occur when the UPS' maximum duty cycle is exceeded.

F. Provide APC, Liebert, or pre-approved equal.

2.5 PRIMARY CONTROL PANEL HARDWARE

A. Provide one (1) primary control panel to each AHU, AC unit, primary hot water system, primary chilled water system, etc.

B. ASHRAE 135 Compliance: Primary control panels shall use the latest version of BACnet/ASHRAE 135 protocol and communicate using ISO 8802-3 (Ethernet) datalink/physical layer protocol.

C. Spare Capacity

1. All primary control panels shall be installed with 10% spare points (of each type) and 10% spare memory capacity for future connections. The type of spare point capacity shall be in the same proportion as the implemented I/O functions of the panel, but in no case shall there be less than two (2) spares of each implemented I/O type. Provide all hardware modules, software modules, processors, power supplies, communication controllers, etc. required to ensure adding a point to the spare point location only requires the addition of the appropriate sensor/actuator and field wiring/tubing.

2. Provide all processors, power supplies and communication controllers so that the implementation of adding a point to the spare point location only requires the addition of the appropriate:

- a. Expansion modules.
- b. Sensor/actuator.
- c. Field wiring/tubing.

D. Provide all necessary hardware for a complete operating system as required. All hardware shall reside in each primary control panel. Primary control panels shall not be dependent upon any higher level computer or another controller for operation.

E. Each primary control panel shall, at a minimum, be provided with:

1. Appropriate NEMA 12 rated metal enclosure.
2. An integral real-time clock.
3. A 32bit, stand-alone, multi-tasking, multi-user, real-time 48M Hz digital control microprocessor module.
4. Primary Network communication module, if needed for primary network communications.

5. Secondary Network communication module, if needed for secondary network communications.
 6. Memory to accommodate all primary control panel software requirements, including but not limited to, its own operating system and databases, including control processes, energy management applications, alarm management applications, historical/trend data for points specified, maintenance support applications, custom processes, operator I/O, dial-up communications. Controller shall have a minimum of 32 MB RAM, 1 MB of flash, and 16K EPROM or EEPROM. Controller shall be provided with battery backup capable of supporting all RAM, clock functions, DDC database and operating programs within the controller for a minimum of 72 hours in the event of power failure or power interruption (if information is not stored in non-volatile memory).
 7. Data collection/ Data Trend module sized for 10,000 data samples.
 8. Power supplies as required for all associated modules, sensors, actuators, etc.
 9. Software modules as required for all sequences of operation, logic sequences and energy management routines. Relay logic is not acceptable.
 10. A portable operator terminal connection port to allow the temporary use of portable devices without interrupting the normal operation of permanently connected printers or terminals.
 11. Monitoring of the status of all HOA switches (related life safety/fire system fans only). The status of the HOA switch shall be available as a BMS data point.
 12. Monitoring of all industry standard types of analog and digital inputs and outputs, without the addition of equipment to the primary control panel.
 13. Auxiliary enclosure for analog output transducers, isolation relays, etc. Auxiliary enclosure shall be part of primary enclosure or mounted adjacent to the primary enclosure.
 14. Local status indication for each digital input and output for constant, up-to-date verification of all point conditions without the need for an operator I/O device. Each primary control panel shall perform diagnostics on all inputs and outputs and a failure of any input or output shall be indicated both locally and at the operator workstation.
 15. Graduated intensity LEDs or analog indication of value for each analog output
- F. The operator shall have the ability to manually override automatic or centrally executed commands at the primary control panels via local, point discrete, on-board hand/off/auto operator override switches. If on board switches are not available, provide separate control panels with HOA switches. Mount panel adjacent to primary control panel. These override switches shall be operable whether the panel processor is operational or not. Provide HOA switch for each digital output, including spares (related life safety/fire system fans only). Provide hand/auto switch and gradual positioning potentiometer for each analog output, including spares (related life safety/fire system fans only).

- G. Each primary control panel shall continuously perform self-diagnostics on all hardware modules and network communications. The primary control panel shall provide both local and remote annunciation of any detected component failures, or repeated failure to establish communication with any system.
- H. All databases and programs shall be stored in non-volatile EEPROM, EPROM and PROM.
- I. Each primary control panel shall support firmware upgrades without the need to replace hardware.
- J. Primary control panels shall provide at least two (2) EIA-232C serial data communication ports for operation of operator I/O devices such as industry standard printers, operator terminals, and portable laptop operator's terminals. Primary control panels shall allow temporary use of portable devices without interrupting the normal operation of permanently connected printers or terminals.
- K. Immunity to power and noise.
 - 1. Controller shall be able to operate at 90% – 110% of nominal voltage rating and shall perform an orderly shutdown below 80% nominal voltage.
 - 2. Operation shall be protected against electrical noise of 5 – 120 Hz and from keyed radios up to 5W at 1m (3').
 - 3. Isolation shall be provided at all primary network terminations, as well as all field point terminations to suppress induced voltage transients consistent with:
 - a. RF-Conducted Immunity (RFCI) per ENV 50141 (IEC 1000-4-6) at 3V.
 - b. Electro Static Discharge (ESD) Immunity per EN 61000-4-2 (IEC 1000-4-2) at 8kV air discharge, 4kV contact.
 - c. Electrical Fast Transient (EFT) per EN 61000-4-4 (IEC 1000-4-4) at 500V signal, 1kV power.
 - d. Output Circuit Transients per UL 864 (2,400V, 10A, 1.2 Joule max).
 - 4. Isolation shall be provided at all Primary Controller's AC input terminals to suppress induced voltage transients consistent with:
 - a. IEEE Standard 587 1980.
 - b. UL 864 Supply Line Transients.
 - c. Voltage Sags, Surge and Dropout per EN 61000-4-11 (EN 1000-4-11).
- L. BMS controllers must be powered off the equipment branch. Applies to all central equipment (AHUs, pumps, condensate pumps, etc.) and any fan serving isolation rooms, protective environment rooms or any other space that must maintain a pressure relationship to its surroundings.

- M. BMS controllers shall be connected to UPS power. Installation shall incorporate a bypass switch to allow for a faulty UPS to be replaced without interrupting power to the controller or controllers it serves.

2.6 PRIMARY CONTROL PANEL SOFTWARE

- A. Furnish the following applications software to form complete operating system for building and energy management as described in this specification.
- B. Provide all necessary software for a complete operating system as required. All software shall reside in each primary control panel. Primary control panels shall not be dependent upon any higher level computer or another controller for operation.
- C. All points, panels and programs shall be identified by a 30 character name and a 16 character point descriptor. The same names shall be displayed at both the primary control panel(s) (via portable terminal or printer) and the PC operator workstation(s).
- D. All digital points shall have a user-defined, 2-state status indication with 8 characters minimum (e.g., Summer, Enabled, Disabled, Abnormal).
- E. System Security
 - 1. User access shall be secured using individual security passwords and user names.
 - 2. Passwords shall restrict the user to the objects, applications and system functions as assigned by the system manager.
 - 3. Primary Controllers shall be able to assign a minimum of 50 passwords access and control priorities to each point individually. The logon password (at any Operator Interface or portable operator terminal) shall enable the operator to monitor, adjust and control only the points that the operator is authorized for. All other points shall not be displayed at the Operator Interface or portable terminal. Passwords and priorities for every point shall be fully programmable and adjustable.
 - 4. User Log On / Log Off attempts shall be recorded.
 - 5. The system shall protect itself from unauthorized use by automatically logging off following the last keystroke. The delay time shall be user-definable.
- F. Each primary control panel shall, at a minimum, be provided with software for:
 - 1. 2-position control, proportional control, proportional plus integral control, proportional, integral, plus derivative control algorithms, all with automatic control loop tuning.
 - 2. Limiting the number of times each piece of equipment may be cycled within any 1-hour period.
 - 3. The system shall provide protection against excessive demand situations during start-up periods by automatically introducing time delays between successive start commands to heavy electrical loads. Upon the resumption of

power, each DDC Controller shall analyze the status of all controlled equipment, compare it with normal occupancy scheduling and turn equipment on or off as necessary to resume normal operations.

4. Priority load shedding (10 zones).
5. Energy management routines including time of day scheduling, calendar-based scheduling, holiday scheduling, temporary schedule overrides, start-stop time optimization, automatic daylight savings time switch over, night setback control, enthalpy switch over, peak demand limiting, temperature-compensated duty cycling, heating/ cooling interlock, supply temperature reset, priority load shedding and power failure restart.
6. Custom, job-specific processes defined by the user, to automatically perform calculations and special control routines and sequences of operations.
 - a. Controllers shall be able to execute custom, job-specific processes defined by the user, to automatically perform calculations and special control routines.
 - b. It shall be possible to use any system measured point data or status, any system calculated data, a result from any process or any user-defined constant in any controller in the system.
 - c. Any process shall be able to issue commands to points in any and all other controllers in the system.
 - d. Processes shall be able to generate operator messages and advisories to other operator I/O devices. A process shall be able to directly send a message to a specified device or cause the execution of a dial-up connection to a remote device such as a printer or pager.
 - e. The custom control programming feature shall be documented via English language descriptors.
 - f. Each controller shall support text comment lines in the operating program to allow for quick troubleshooting, documentation and historical summaries of program development.
 - g. Controller shall provide a HELP function key, providing enhanced context sensitive on-line help with task orientated information from the user manual.
7. Generate and receive automatic and manual operator messages and advisories.
8. Comment lines for all programs.
9. Distributed independent alarm analysis and filtering. Reporting of selected alarms during system shutdown and start-up shall be automatically inhibited. A minimum of 6 priority levels shall be provided for each point.
10. Automatically accumulate and store run-time hours for all digital points.

11. Automatically sample, calculate and store consumption totals on a daily, weekly or monthly basis for all analog and pulse input type points.
- G. Trend data shall be stored at the primary control panels and automatically uploaded to the PC workstation. Uploads shall occur based on user-defined intervals, manual commands, or automatically when the trend buffer is 80% full. All trend data shall be available for use in any 3rd party personal computer applications located in the BMS.
 - H. Primary control panels shall be able to assign password access and control priorities to each system individually. The logon password (at any PC workstation(s) or POT) shall enable the operator to monitor, adjust and/or control only the systems, programs, primary control panel and/or secondary control panels that the operator is authorized for. All other systems, programs, primary and secondary control panels shall not be displayed at the PC workstation, or POT. Passwords and priority levels for each system, program, primary control panel and secondary control panel shall be fully programmable and adjustable.
 - I. Primary control panels shall be able to access any data from, or send control commands and alarm reports directly to, any other primary control panel or combination of controllers on the network without dependence upon a central or intermediate processing device. Primary control panels shall also be able to send alarm reports to multiple operator workstations without dependence upon a central or intermediate processing device.
 - J. Alarm management shall be provided to monitor and direct alarm information to operator devices. Each DDC Controller shall perform distributed, independent alarm analysis and filtering to minimize operator interruptions due to non-critical alarms, minimize network traffic and prevent alarms from being lost. At no time shall the DDC Controllers ability to report alarms be affected by either operator or activity at a PC workstation, local I/O device or communications with other panels on the network.
 1. All alarm or point change reports shall include the point's English language description and the time and date of occurrence.
 2. The user shall be able to define the specific system reaction for each point. Alarms shall be prioritized to minimize nuisance reporting and to speed operator response to critical alarms. A minimum of 6 priority levels shall be provided for each point. Point priority levels shall be combined with user definable destination categories (PC, printer, DDC Controller, etc.) to provide full flexibility in defining the handling of system alarms. Each DDC Controller shall automatically inhibit the reporting of selected alarms during system shutdown and start-up. Users shall have the ability to manually inhibit alarm reporting for each point.
 3. Alarm reports and messages shall be routed to user-defined list of operator workstations or other devices based on time and other conditions. An alarm shall be able to start programs, print, be logged in the event log, generate custom messages and display graphics.

4. In addition to the point's descriptor and the time and date, the user shall be able to print, display or store a 200 character alarm message to more fully describe the alarm condition or direct operator response.
 - a. Each DDC Controller shall be capable of storing a library of at least 50 alarm messages. Each message may be assignable to any number of points in the Controller.
5. Operator-selected alarms shall be capable of initiating a call to a remote operator device.

K. Scheduling:

1. Provide a comprehensive menu driven program to automatically start and stop designated object or group of objects in the system according to a stored time.
2. It shall be possible to define a group of objects as a custom event (i.e., meeting, athletic activity, etc.). Events can then be scheduled to operate all necessary equipment automatically.
3. For points assigned to one (1) common load group, it shall be possible to assign variable time delays between each successive start and stop within that group.
4. The operator shall be able to define the following information:
 - a. Time, day.
 - b. Commands such as on, off, auto and so forth.
 - c. Time delays between successive commands.
 - d. There shall be provisions for manual overriding of each schedule by an appropriate operator.
5. It shall be possible to schedule calendar-based events up to 1 year in advance based on the following:
 - a. Weekly Schedule. Provide separate schedules for each day of the week. Each of these schedules should include the capability for start, stop, optimal start, optimal stop and night economizer. When a group of objects are scheduled together as an Event, provide the capability to adjust the start and stop times for each member.
 - b. Exception Schedules. Provide the ability for the operator to designate any day of the year as an exception schedule. Exception schedules may be defined up to a year in advance. Once an exception schedule is executed, it will be discarded and replaced by the standard schedule for that day of the week.
 - c. Holiday Schedules. Provide the capability for the operator to define up to 99 special or holiday schedules. These schedules may be placed on the scheduling calendar and will be repeated each year. The operator shall be able to define the length of each holiday period.

- L. Temperature-compensated duty cycling.
 - 1. The DCCP (Duty Cycle Control Program) shall periodically stop and start loads according to various patterns.
 - 2. The loads shall be cycled such that there is a net reduction in both the electrical demands and the energy consumed.
- M. Automatic Daylight Savings Time Switchover: The system shall provide automatic time adjustment for switching to/from Daylight Savings Time.
- N. Night setback control. The system shall provide the ability to automatically adjust setpoints for night control.
- O. Enthalpy switchover (economizer). The Primary Controller Software shall control the position of the air handler relief, return and outside air dampers. If the outside air enthalpy is below the return air enthalpy, the software will modulate the dampers to provide 100% outside air. The user will be able to quickly changeover to an economizer system based on enthalpy and will be able to override the economizer cycle and return to minimum outside air operation at any time.
- P. PID Control. A PID (proportional-integral-derivative) algorithm with direct or reverse action and anti-windup shall be supplied. The algorithm shall calculate a time-varying analog value that is used to position an output or stage a series of outputs. The controlled variable, set point and PID gains shall be user-selectable.
- Q. Sequencing. Provide application software based upon the sequences of operation specified to properly sequence equipment.
- R. Staggered Start:
 - 1. This application shall prevent all controlled equipment from simultaneously restarting after a power outage. The order, in which equipment (or groups of equipment) is started, along with the time delay between starts, shall be user definable.
 - 2. Upon the resumption of power, each Primary Controller shall analyze the status of all controlled equipment, compare it with normal occupancy scheduling and turn equipment on or off as necessary to resume normal operations.
- S. Totalization:
 - 1. Run-Time Totalization. Primary Controllers shall automatically accumulate and store run-time hours for all digital input and output points. A high runtime alarm shall be assigned, if required, by the operator.
 - 2. Consumption totalization. Primary Controllers shall automatically sample, calculate and store consumption totals on a daily, weekly or monthly basis for all analog and digital pulse input type points.
 - 3. Event totalization. Primary Controllers shall have the ability to count events such as the number of times a pump or fan system is cycled on and off. Event totalization shall be performed on a daily, weekly or monthly basis for all

points. The event totalization feature shall be able to store the records associated with events before reset.

4. Totalization calculated on the front end is acceptable.
- T. A variety of historical data collection utilities shall be provided to manually or automatically sample, store and display system data for all points.
1. DDC Controllers shall store point history data for selected analog and digital inputs and outputs:
 - a. Any point, physical or calculated may be designated for trending. Any point, regardless of physical location in the network, may be collected and stored in each DDC Controllers point group. Two (2) methods of collection shall be allowed: either by a pre-defined time interval or upon a pre-defined change of value. Sample intervals of 1 minute to 7 days shall be provided. Each DDC Controller shall have a dedicated RAM-based buffer for trend data and shall be capable of storing a minimum of 10,000 data samples.
 - b. Trend data shall be stored at the DDC Controllers and automatically uploaded to the workstation. Uploads shall occur based upon user-defined interval, manual command or automatically when the trend buffers are 80% full. All trend data shall be available for use in any third party personal computer applications located on the MLN.
 - c. DDC Controllers shall also provide high resolution sampling capability for verification of control loop performance. Operator-initiated automatic and manual loop tuning algorithms shall be provided for a minimum of 36 operator-selected PID control loops. Provide capability to view or print trend and tuning reports.
 - 1) The controller shall perform a step response test with a minimum 1-second resolution, evaluate the trend data, calculate the new PID gains and input these values into the selected LOOP statement.
 - 2) Loop tuning shall be capable of being initiated either locally at the DDC Controller, from a network workstation, or remotely using web page interface. For all loop tuning functions, access shall be limited to authorized personnel through password protection.
 - 3) Controllers shall have automatic loop tuning function disabled as a default.
- U. DDC Controllers shall automatically accumulate and store run-time hours for all digital input and output points.
- V. DDC Controllers shall automatically sample, calculate and store consumption totals on a daily, weekly, or monthly basis for all analog and digital pulse input type points.
- W. DDC Controllers shall count events such as the number of times a pump or fan system is cycled on and off. Event totalization shall be performed on a daily, weekly

and monthly basis for all points. The event totalization feature shall be able to store the records associated with a minimum of 9,999.9 events before reset.

- X. Totalization calculated on the front end is acceptable.

2.7 SECONDARY CONTROL PANEL HARDWARE

- A. ASHRAE 135 Compliance: Secondary control panels shall use the latest version of BACnet/ASHRAE 135 protocol over MS/TP.
- B. Each secondary control panel shall operate as a stand-alone controller capable of performing its user selectable control routines independently of any other controller in the system. Each secondary control panel shall be a microprocessor-based, multi-tasking, real-time digital control processor.
- C. Each Primary Controller shall be able to communicate with secondary controllers over the Secondary Network to control terminal equipment only.
- D. Each secondary controller shall include all point inputs and outputs necessary to perform the specified control sequences. The secondary controller shall accept input and provide output signals that comply with industry standards. Controllers utilizing proprietary control signals shall not be acceptable. Outputs may be utilized either for 2-state, modulating, floating or proportional control, allowing for additional system flexibility.
- E. Each secondary control panel shall, at a minimum, be provided with:
 - 1. Appropriate NEMA rated enclosure.
 - 2. A stand-alone real-time digital control microprocessor module.
 - 3. Secondary network communications ability.
 - 4. Power supplies as required for all associated modules, sensors, actuators, etc.
 - 5. Input/output points as required.
 - 6. Software as required for all sequences of operation, logic sequences and energy management routines. Relay logic is not acceptable.
 - 7. A portable operator terminal connection port.
 - 8. Auxiliary enclosure for analog output transducers, isolation relays, etc. Auxiliary enclosure shall be part of primary enclosure or mounted adjacent primary enclosure.
 - 9. Local LED status indication for each digital input and output.
 - 10. Each controller measuring air volume shall include provisions for manual and automatic calibration of the differential pressure transducer in order to maintain stable control and insuring against drift over time.
 - 11. Each controller measuring air volume shall include a differential pressure transducer.

12. Fan speed controller for fan powered VAV boxes.
 13. Fan relay for fan powered VAV boxes and fan coil units.
- F. Communication. Each controller shall perform its primary control function independent of other Secondary Network communication or if Secondary Network communication is interrupted. Reversion to a fail-safe mode of operation during Secondary Network interruption is not acceptable.
 - G. Control Algorithms. The controller shall receive its real-time data from the Primary Controller time clock to insure Secondary Network continuity. Each controller shall include algorithms incorporating proportional, integral and derivative (PID) gains for all applications. All PID gains and biases shall be field-adjustable by the user via room sensor LCD or the portable operator's terminal as specified herein. Controllers that incorporate proportional and integral (PI) control algorithms only shall not be acceptable.
 - H. Control Applications. Operating programs shall be field-selectable for specific applications. In addition, specific applications may be modified to meet the user's exact control strategy requirements, allowing for additional system flexibility. Controllers that require factory changes of all applications are not acceptable.
 - I. Calibration. Each controller shall include provisions for manual and automatic calibration of the differential pressure transducer in order to maintain stable control and insuring against drift over time.
 1. Manual calibration may be accomplished by either commanding the actuator to 0% via the POT or by depressing the room sensor override switch. Calibration of the transducer at the controller location shall not be necessary.
 - J. Each secondary control panel shall continuously perform self-diagnostics on all hardware and secondary network communications. The secondary control panel shall provide both local and remote annunciation of any detected component failures or repeated failure to establish communication to the system.
 - K. Controllers shall include all point inputs and outputs necessary to perform the specified control sequences. As a minimum, 50% of the point outputs shall be of the Universal type; that is, the outputs may be utilized either as modulating or two-state, allowing for additional system flexibility. In lieu of Universal outputs, provide a minimum of 50% spare outputs of each type via additional point termination boards or controllers. Analog outputs shall be industry standard signals such as 24 VAC floating control, allowing for interface to a variety of modulating actuators. Terminal equipment controllers utilizing proprietary control signals and actuators shall not be acceptable.
 - L. Provide each secondary control panel with sufficient memory to accommodate point databases, operating programs, local alarming and local trending. All databases and programs shall be stored in non-volatile EEPROM, EPROM and PROM. The controllers shall be able to return to full normal operation without user intervention after a power failure of unlimited duration. Provide uninterruptible power supplies (UPSs) of sufficient capacities for all terminal controllers that do not meet this protection requirement. Operating programs shall be field-selectable for specific applications. In addition, specific applications may be modified to meet the user's exact control strategy requirements, allowing for additional system flexibility.

Controllers that require factory changes of all applications are not acceptable. Controller shall have a minimum of 16K EPROM or EEPROM.

- M. The secondary control panels shall be powered from a 24 VAC source provided by this contractor and shall function normally under an operating range of 18 – 28 VAC (-25% – 17%), allowing for power source fluctuations and voltage drops. Install plenum data line and sensor cable in accordance with local code and NEC. The BMS contractor shall provide a dedicated power source and separate isolation transformer for each controller to function normally under the specified operating range. The controllers shall also function normally under ambient conditions of 32° – 122°F (0° – 50°C) and 10% – 95% RH (non-condensing). Provide each controller with a suitable cover or enclosure to protect the intelligence board assembly. Power supply must be rated at a minimum of 125% of power consumption and shall be of the fused or current limiting type. The BMS contractor shall provide 24 VAC power to the terminal units by utilizing:
1. The existing line voltage power trunk and installing separate isolation transformers for each controller.
 2. Dedicated line voltage power source and isolation transformers at a central location and installing 24 VAC power trunk to supply multiple controllers in the area.
- N. Environment. The controllers shall function normally under ambient conditions of 32° – 122°F (0° – 50°C) and 10% – 95% RH (non-condensing). Provide each controller with a suitable cover or enclosure to protect the circuit board assembly.
- O. Immunity to noise. Operation shall be protected against electrical noise of 5 – 120Hz and from keyed radios up to 5W at 1m (3').

2.8 SECONDARY CONTROL PANEL SOFTWARE

- A. Provide all necessary software for a complete operating system as required. All software shall reside in each secondary control panel. Secondary control panels shall not be dependent upon any higher level computer or another controller for operation.
- B. Secondary control panel software configured for CAV or VAV control algorithms shall include provisions for manual and automatic calibration of attached differential pressure transducer in order to maintain stable control and insuring against drift over time. Calibration shall be accomplished by stroking the terminal unit damper actuator to a 0% position so that a 0 CFM air volume reading is sensed. The controller shall automatically accomplish this whenever the system mode switches from occupied to unoccupied or vice versa. Manual calibration may be accomplished by either commanding the actuator to 0% via the POT or by depressing the room sensor override switch. Calibration of the transducer at the controller location shall not be necessary.
- C. Each secondary controller shall perform its primary control function independent of primary controller LAN communication, or if LAN communication is interrupted. Reversion to a fail-safe mode of operation during LAN interruption is not acceptable. The controller shall receive its real-time data from the primary control panel time clock to insure LAN continuity. Each controller shall include algorithms incorporating proportional, integral and derivative (PID) control for all applications.

All PI parameters shall be field-adjustable by the user via a portable operator's terminal.

- D. Secondary control panels shall support pressure independent terminal boxes including VAV cooling only, VAV with hot water or electric reheat, Fan-powered VAV and Fan-powered VAV with hot water or electric reheat. All VAV box control applications shall be field-selectable such that a single controller may be used in conjunction with any of the above types of terminal units to perform the specified sequences of control. This requirement must be met in order to allow for future design and application changes and to facilitate system expansions. Controllers that require factory application changes are not acceptable.

2.9 WEB BASED OPERATOR INTERFACE

- A. Operator Interface. Web server shall reside on high-speed network with primary controllers. Each standard browser connected to server shall be able to access all system information. In addition to the primary operator interface, the system shall include a secondary interface compatible with a locally available commercial wireless network and viewable on a commercially available wireless device such as a Wireless Access Protocol (WAP) enabled cellular telephone or personal digital assistant (PDA). This secondary interface may be text-based and shall provide a summary of the most important data. As a minimum, the following capabilities shall be provided through this interface:
 - 1. An operator authentication system that requires an operator to log in before viewing or editing any data and which can be configured to limit the privileges of an individual operator.
 - 2. The ability to view and acknowledge any alarm in the system. Alarms or links to alarms shall be provided on a contiguous list so the operator can quickly view all alarms.
 - 3. A summary page or pages for each piece of equipment in the system. This page shall include the current values of all critical I/O points and shall allow the operator to lock binary points on or off and to lock analog points to any value within their range.
 - 4. Navigation links that allow the operator to quickly navigate from the home screen to any piece of equipment in the system and then return to the home screen. These links shall be arranged in a hierarchical fashion, such as navigating from the home screen to a particular building, then to a specific floor in the building and then to a specific room or piece of equipment.
- B. Communication. Web server or workstation and controllers shall communicate using BACnet protocol. Web server or workstation and control network backbone shall communicate using ISO 8802-3 (Ethernet) Data Link/Physical layer protocol and BACnet/IP addressing as specified in the latest version of ANSI/ASHRAE 135, BACnet Annex J.
- C. Hardware. Each workstation or web server shall consist of the following:
 - 1. Industry-standard hardware shall meet or exceed DDC system manufacturer's recommended specifications and shall meet requirements included herein. Hard disk shall have sufficient memory to store system software, 1 year of

data for trended points and a system database at least twice the size of the existing database at system acceptance. Configure computers and network connections if multiple computers are required to meet specified memory and performance.

- D. Operator Functions. Operator interface shall allow each authorized operator to execute the following functions as a minimum:
1. Log In and Log Out. System shall require user name and password to log in to operator interface.
 2. Point-and-click Navigation. Operator interface shall be graphically based and shall allow operators to access graphics for equipment and geographic areas using point-and-click navigation.
 3. View and Adjust Equipment Properties. Operators shall be able to view controlled equipment status and to adjust operating parameters such as setpoints, PID gains, on and off controls and sensor calibration.
 4. View and Adjust Operating Schedules. Operators shall be able to view scheduled operating hours of each schedulable piece of equipment on a weekly or monthly calendar-based graphical schedule display, to select and adjust each schedule and time period and to simultaneously schedule related equipment. System shall clearly show exception schedules and holidays on the schedule display.
 5. View and Respond to Alarms. Operators shall be able to view a list of currently active system alarms, to acknowledge each alarm and to clear (delete) unneeded alarms.
 6. View and Configure Trends. Operators shall be able to view a trend graph of each trended point and to edit graph configuration to display a specific time period or data range. Operator shall be able to create custom trend graphs to display on the same page data from multiple trended points.
 7. View and Configure Reports. Operators shall be able to run preconfigured reports, to view report results and to customize report configuration to show data of interest.
 8. Manage Control System Hardware. Operators shall be able to view controller status, to restart (reboot) each controller and to download new control software to each controller.
 9. Manage Operator Access. Typically, only a few operators are authorized to manage operator access. Authorized operators shall be able to view a list of operators with system access and of functions they can perform while logged in. Operators shall be able to add operators, to delete operators and to edit operator function authorization. Operator shall be able to authorize each operator function separately.
- E. System Software.

1. Operating System. Web server shall have an industry-standard professional-grade operating system. Acceptable systems include Microsoft Windows 10. The operating system shall be coordinated with MMC IT.
 2. System Graphics. Operator interface shall be graphically based and shall include at least one (1) graphic per piece of equipment, air handling unit or occupied zone, graphics for each chilled water and hot water system and graphics that summarize conditions on each floor. The BMS contractor shall review and standardize these graphics with the owner on site team.
 - a. All system graphic updates must be approved by MMC HVAC Lead.
 3. Provide links on each graphic to PDF files of the associated sequence of operation, flow diagram, and wiring diagrams.
 4. Functionality. Graphics shall allow operator to monitor system status, to view a summary of the most important data for each controlled zone or piece of equipment, to use point-and-click navigation between zones or equipment and to edit setpoints and other specified parameters.
 5. Animation. Graphics shall be able to animate by displaying different image files for changed object status.
 6. Alarm Indication. Indicate areas or equipment in an alarm condition using color or other visual indicator.
 7. Format. Graphics shall be saved in an industry-standard format such as BMP, JPEG, PNG or GIF. Web-based system graphics shall be viewable on browsers compatible with World Wide Web Consortium browser standards. Web graphic format shall require no plug-in (such as HTML and JavaScript) or shall only require widely available no-cost plug-ins (such as Active-X and Macromedia Flash).
- F. System Tools. System shall provide the following functionality to authorized operators as an integral part of the operator interface or as stand-alone software programs. If furnished as part of the interface, the tool shall be available from each workstation or web browser interface. If furnished as a stand-alone program, software shall be installable on standard IBM-compatible PCs with no limit on the number of copies that can be installed under the system license.
1. Automatic System Database Configuration. Each workstation or web server shall store on its hard disk a copy of the current system database, including controller firmware and software. Stored database shall be automatically updated with each system configuration or controller firmware or software change.
 2. Controller Memory Download. Operators shall be able to download memory from the system database to each controller.
 3. System Configuration. Operators shall be able to configure the system.
 4. Online Help. Context-sensitive online help for each tool shall assist operators in operating and editing the system.

5. Security. System shall require a user name and password to view, edit, add or delete data.
6. Operator Access. Each user name and password combination shall define accessible viewing, editing, adding and deleting functions in each system application, editor and object.
7. Automatic Log Out. Automatically log out each operator if no keyboard or mouse activity is detected. Operators shall be able to adjust automatic log out delay.
8. Encrypted Security Data. Store system security data including operator passwords in an encrypted format. System shall not display operator passwords.
9. System Diagnostics. System shall automatically monitor controller and I/O point operation. System shall annunciate controller failure and I/O point locking (manual overriding to a fixed value).
10. Alarm Processing. System input and status objects shall be configurable to alarm on departing from and on returning to normal state. Operator shall be able to enable or disable each alarm and to configure alarm limits, alarm limit differentials, alarm states and alarm reactions for each system object. Configure and enable alarm points as specified.
11. Alarm Messages. Alarm messages shall use an English language descriptor without acronyms or mnemonics to describe alarm source, location and nature.
12. Alarm Reactions. Operator shall be able to configure (by object) actions workstation or web server shall initiate on receipt of each alarm. As a minimum, workstation or web server shall be able to log, print, start programs, display messages, send e-mail, send page and audibly annunciate.
13. Alarm Maintenance. Operators shall be able to view system alarms and changes of state chronologically, to acknowledge and delete alarms and to archive closed alarms to the workstation or web server hard disk from each workstation or web browser interface.
14. Trend Configuration. Operator shall be able to configure trend sample or change of value (COV) interval, start time and stop time for each system data object and shall be able to retrieve data for use in spreadsheets and standard database programs. Controller shall sample and store trend data and shall be able to archive data to the hard disk. Configure trends as specified or required by the Owner.
15. Object and Property Status and Control. Operator shall be able to view and to edit if applicable, the status of each system object and property by menu, on graphics or through custom programs.
16. Reports and Logs. Operator shall be able to select, to modify, to create and to print reports and logs. Operator shall be able to store report data in a format accessible by standard spreadsheet and word processing programs.

17. Standard Reports. Furnish the following standard system reports:
18. Objects. System objects and current values filtered by object type, by status (in alarm, locked, normal), by equipment, by geographic location or by combination of filter criteria.
19. Alarm Summary. Current alarms and closed alarms. System shall retain closed alarms for an adjustable period.
20. Logs. System shall log the following to a database or text file and shall retain data for an adjustable period:
 - a. Alarm History.
 - b. Trend Data. Operator shall be able to select trends to be logged.
 - c. Operator Activity. At a minimum, system shall log operator log in and log out, control parameter changes, schedule changes and alarm acknowledgment and deletion. System shall date and time stamp logged activity.
21. Custom Reports. Operator shall be able to create custom reports that retrieve data, including archived trend data, from the system, that analyze data using common algebraic calculations and that present results in tabular or graphical format. Reports shall be launched from the operator interface.
22. Graphics Generation. Graphically based tools and documentation shall allow Operator to edit system graphics, to create graphics and to integrate graphics into the system. Operator shall be able to add analog and binary values, dynamic text, static text and animation files to a background graphic using a mouse.
23. Graphics Library. Complete library of standard HVAC equipment graphics shall include equipment such as chillers, boilers, air handlers, terminals, fan coils and unit ventilators. Library shall include standard symbols for other equipment including fans, pumps, coils, valves, piping, dampers and ductwork. Library graphic file format shall be compatible with graphics generation tools.
24. Custom Application Programming. Operator shall be able to create, edit, debug and download custom programs. System shall be fully operable while custom programs are edited, compiled and downloaded. Programming language shall have the following features:
25. Language. Language shall be graphically based and shall use function blocks arranged in a logic diagram that clearly shows control logic flow. Function blocks shall directly provide functions listed below and operators shall be able to create custom or compound function blocks.
26. Programming Environment. Tool shall provide a full-screen, cursor-and-mouse-driven programming environment that incorporates word processing features such as cut and paste. Operators shall be able to insert, add, modify and delete custom programming code and to copy blocks of code to a file library for reuse in other control programs.

27. Independent Program Modules. Operator shall be able to develop independently executing program modules that can disable, enable and exchange data with other program modules.
28. Debugging and Simulation. Operator shall be able to step through the program observing intermediate values and results. Operator shall be able to adjust input variables to simulate actual operating conditions. Operator shall be able to adjust each step's time increment to observe operation of delays, integrators and other time-sensitive control logic. Debugger shall provide error messages for syntax and for execution errors.
29. Conditional Statements. Operator shall be able to program conditional logic using compound Boolean (AND, OR and NOT) and relational (EQUAL, LESS THAN, GREATER THAN, NOT EQUAL) comparisons.
30. Mathematical Functions. Language shall support floating-point addition, subtraction, multiplication, division and square root operations, as well as absolute value calculation and programmatic selection of minimum and maximum values from a list of values.
31. Variables: Operator shall be able to use variable values in program conditional statements and mathematical functions.
 - a. Time Variables. Operator shall be able to use predefined variables to represent time of day, day of the week, month of the year and date. Other predefined variables or simple control logic shall provide elapsed time in seconds, minutes, hours and days. Operator shall be able to start, stop and reset elapsed time variables using the program language.
 - b. System Variables. Operator shall be able to use predefined variables to represent status and results of Controller Software and shall be able to enable, disable and change setpoints of Controller Software as described in Controller Software section.

2.10 INTERNET BASED COMMUNICATION

A. Web Based Operator Interface

1. The BMS shall provide a web based graphical interface that allows users to access the BMS data via the Internet, extranet, or Intranet. The interface shall use HTML based ASP pages to send and receive data from the BMS to a web browser.
2. A web server computer will be supplied (if required). The web server shall support browser access via a modern web browser as approved by MMC IT.
3. All information exchanged over Internet shall be optionally encrypted and secure via SSL (provided by Owner).
4. Access to the web interface shall be password protected. Users' rights and privileges to points and graphics will be the same as those assigned at the BMS workstation. An option will exist to only allow users "read" access via

the web browser, while maintaining "command" privileges via the BMS workstation.

5. The web interface shall not require modification or creation of HTML or ASP pages using an HTML editor. All graphics available at the BMS graphical workstation shall be automatically generated to a web server.
6. The web based interface shall provide the following functionality to users, based on their access and privilege rights:
 - a. Logon Screen - allows the user to enter their name, password and domain name for logging into the web server.
 - b. Alarm Display - a display of current BMS System alarms to which the user has access will be displayed. Users will be able to acknowledge and erase active alarms and link to additional alarm information including alarm messages. Any alarm acknowledgments initiated through the web interface will be recorded to the BMS System activity log.
 - c. Graphic Display - Display of system graphics, including animated motion, available in the BMS system workstation will be available for viewing over the web browser. Software that requires the creation of dedicated "web" graphics in order to display the via the browser interface will not be acceptable. A graphic selector list will allow users to select any graphics to which they have access. Graphics displays will automatically refresh with the latest change of values. Users will have the ability to recommand and override points from the graphic display as determined by their user account rights.
 - 1) All system graphic updates must be approved by MMC HVAC Lead.
 - d. Point Details - users will have access to point detail information including operational status, operational priority, physical address and alarm limits, for point objects to which they have access.
 - e. Point Commanding - users will be able to override and command points they have access to via the web browser interface. Any commands or overrides initiated via the web browser interface will be written to the BMS system central workstation activity log.
7. The web server licensing options will allow concurrent access by a minimum of five (5) browser connections.
8. Internet connections, ISP services, as well as necessary firewalls or proxy servers shall be provided by the owner as required to support the web access feature.

2.11 SENSORS

- A. Electronic Sensors: Vibration and corrosion resistant; for wall, immersion or duct mounting as required.
- B. Instruments and control devices shall be provided for all required points detailed herein. Instruments shall have accuracies as stated herein. Instrument

characteristics such as hysteresis, relaxation time, span, and maximum and minimum limits, shall be accounted for in applications of instruments and controls. Not all devices specified may be required for this project.

- C. Field wiring for each digital device shall be as per the manufacturer's standard. The details of the wiring shall be included in the submittal.
- D. Sensors for duct locations shall not be affected by vibrations encountered in normal duct systems.
- E. Temperature Sensors
 - 1. Temperature sensors used in duct or space sensing applications shall be thermistors. Temperature sensors shall have the following characteristics.
 - a. Accuracy: $\pm 0.5^{\circ}\text{F}$.
 - b. Wire: Twisted, shielded-pair cable.
 - 2. Insertion Elements in Ducts: Single point; use where not affected by temperature stratification or where ducts are smaller than 9sq ft. (1sq m). The length of the sensor shall be a minimum of one-third of the width of the duct with a maximum length of eighteen (18) inches. Provide duct mounted metal housing with conduit entrance.
 - 3. Averaging Elements in Ducts: Use where prone to temperature stratification or where ducts are larger than 9sq ft (1sq m); length as required. The length of the sensor shall be twelve (12) feet minimum or one (1) linear foot per every one (1) sq ft of cut cross section, whichever is greater. Provide duct mounted metal housing with conduit entrance and mounting clips
 - 4. Provide one (1) averaging temperature sensor for each preheat or heating coil section in an air handling unit. The sensor shall be installed on the discharge side of each preheat coil.
 - 5. Insertion Elements for Liquids: Provide 304 stainless steel thermowell with tapered pattern, $\frac{3}{4}$ inch NPT external connection, $\frac{1}{2}$ inch internal thread. Include lagging extension equal to insulation thickness where installed in insulated piping. Insertion length shall be a minimum of $\frac{1}{3}$ of pipe diameter but in no case shall be less than 2 $\frac{1}{2}$ inches and a maximum of $\frac{3}{4}$ pipe diameter or 6 inches, whichever is smaller.
 - 6. Space sensors:
 - a. Set-Point Adjustment: Exposed.
 - b. Set-Point Indication: Exposed.
 - c. LCD display for temperature reading.
 - d. Color: White.
 - e. Orientation: Vertical.

- f. Space sensors provided for existing facilities shall match existing site standard. Coordinate with the owner and the architect for all requirements.
- F. Humidity Sensors: Bulk polymer sensor element
1. Duct and Outside Humidity Air Sensors:
 - a. Factory calibrated to an accuracy of $\pm 2\%$ RH over a range of 0%-100% RH
 - b. With element guard and mounting plate, span of 0 to 100% RH.
 - c. Sensors shall be Vaisala HMD60/70 Series or pre-approved equal.
 2. Sensors shall be provided with a 3-point NIST traceable calibration certificate.
- G. Static Pressure Transmitter: Nondirectional sensor with suitable range for expected input and temperature compensated.
1. Accuracy: 1% of full scale with repeatability of 0.1%.
 2. Output: 4 – 20 mA.
 3. Building Static-Pressure Range: 0-0.25" wg (0-62 Pa).
 4. Duct Static-Pressure Range: 0-5" wg (0-1243 Pa).
 5. Provide a Setra M264 or pre-approved equal.
 6. These sensors shall be used for control of fan VFDs, monitoring of filter DP, etc.
- H. Pressure Transmitters: Direct acting for gas, liquid or steam service; range suitable for system; proportional output 4-20 mA.
1. 2-wire variable capacitance.
 2. NEMA 4X enclosure.
 3. Rated for 0% to 100% RH and -40°F – 185°F.
 4. Dual component housing with a moisture barrier completely isolating the electronic circuitry from the field wiring and calibration terminals.
 5. Operates with a 10 – 55 VDC power supply.
 6. Zero and span adjustments.
 7. Accuracy shall be $\pm 0.075\%$ of calibrated span.
 8. Transmitter shall be furnished complete with coplanar style factory mounted 5-valve manifold and mounting bracket manufactured by Rosemount Model 305 or pre-approved equal.
 9. Provide Rosemount 2051 or pre-approved equal.

I. Damper End Switches

1. Provide a heavy-duty switch with plug-in, oil tight, watertight and NEMA 3 construction (unless exposed to outside air type conditions) sensing of damper position. Shall be rated to operate from -40°F - 212°F (-40°C - 100°C). Shall have a side rotary switch for use with interchangeable levers. Shall have LED position and operation indicators. Shall be Omron D4A series or pre-approved equal. (For outside air dampers involved in helipad sequence).
2. Provide a compact, SPDT switch for sensing of damper position. Shall be rated to operate from -13°F - 158°F. Shall have a side rotary switch for use with interchangeable levers. Shall be Telemecanique XCKL series or pre-approved equal.

J. Water Differential Pressure Switches

1. Low Rise: Hermetically sealed SPDT contacts; stainless steel bourdon tube (or bellows) sensing element; fixed deadband; setpoint shall be at about midpoint of operating range; electrical rating of 5A at 120 VAC; manual adjustable setpoint; vibration resistant; weatherproof enclosure; snap-acting switch type. Switch shall be capable of sustaining 75 psig in either direction. High and low ports shall be ¼ inch NPT.

K. Air Differential Pressure Switches

1. Diaphragm type air differential pressure switches with die-cast aluminum housing, adjustable setpoint and minimum 5A switch rating at 120 VAC, SPST switches and the switch pressure range shall be suited for the application. Switch shall be automatic or manual reset type. Manual reset switches shall be Dwyer 1800 series and automatic reset switches shall be Dwyer 1900 series. High and low ports shall be 1/8 inch NPT connected to angle type tips designed to sense pressure.

L. Point Leak Detector

1. Leak detector shall have mounting feet with legs adjustable up to 1-1/2", gold-plated water detection probes, adjustable height, a green LED to indicate power, a red LED to indicate water detected, SPDT alarm contacts. The enclosure shall be cast aluminum, weatherproof with adjustable legs. The leak detector shall operate between 11 and 27 VAC/DC. Provide Kele and Associates WD-1B, Liebert LT 410 or preapproved equal.

M. Equipment operation sensors as follows:

1. Status Inputs for Electric Motors: Current sensor with current transformers, adjustable and set to 175% of rated motor current.

N. Current Sensing Relay

1. Provide and install current sensors for all motor status points. Current sensor shall combine a status sensor for monitoring positive status and a command relay for starting or stopping motors in a single package. Current sensor shall be split core, 2-wire, loop powered and sized for expected amperage. Unit

shall be UL listed. Provide status LEDs for current sensed below setpoint, current sensed above setpoint and loop power failure. The current sensor output shall be N.O., solid state and rated for 0.1A at 30 VAC/DC. The relay output shall be N.O. and rated for 5A resistive, 3A inductive at 30 VDC, 240 VAC. Current sensor with command relay shall be a Hawkeye model H938 or pre-approved equal.

O. Current Sensor

1. Provide and install current sensors for all motor status points. Current sensor shall be split core, 2-wire, loop powered and sized for expected amperage. Unit shall be UL listed. Provide status LEDs for current sensed below setpoint, current sensed above setpoint and loop power failure. The current sensor output shall be N.O., solid state and rated for 0.1A at 30 VAC/DC. Current sensor shall be manufactured by Hawkeye or pre-approved equal.

2.12 AQUASTATS

- A. Aquastats shall be a SPDT or SPST switch, strap-on mountable, liquid bulb type used for high or low limit application. The temperature range shall be between 65°F TO 200°F and with a differential temperature adjustable range of 5°F TO 30°F. They shall be mounted on the inlet piping and have an external adjustable temperature setpoint. Provide Honeywell L6006C1018 or pre-approved equal.

2.13 THERMOSTATS

- A. Electric Low-Limit Duct Thermostat (Freezestat): Snap-acting, single-pole, single-throw, manual-reset switch that trips if temperature sensed across any 12" of bulb length is equal to or below set point. Setpoint shall be adjustable.
1. Bulb Length: Minimum 20'.
 2. Quantity: one (1) thermostat for each cooling coil or for every 20 sq ft of coil surface, whichever is greater.
 3. Each freezestat shall be an input to the BMS and shall be separately alarmed.
 4. Reset shall be manual.
 5. Provide JCI A70 series or pre-approved equal.

2.14 STEAM FLOW METERS

- A. Vortex Steam Flow Meter
1. Accuracy: +1% of reading.
 2. Output: 4-20 mA.
 3. Range: Appropriate for application.
 4. 316 stainless steel valve ball.
 5. Grade CF8M stainless steel manifold body.

6. Nema 4X enclosure.
7. The furnished flowmeter shall be a VLM20 Spirax-Sarco or approved equal.

2.15 WATER ENERGY AND FLOW METERS

A. Insertion Electromagnetic Meters

1. Mag meter specification:
 - a. Size and flow range shall be selected by the contractor and approved by the engineer.
 - b. 304 SS tube material.
 - c. Teflon (PTFE) lining material.
 - d. 316L SS electrode material.
 - e. Standard electrode type (two).
 - f. Carbon steel flange material – ANSI rated.
 - g. Remote mounted transmitter.
 - h. Local display.
 - i. NEMA 4 enclosure.
 - j. Accuracy= 0.5 %.
 - k. Provide Rosemount Series 8700.
2. Provide required temperature transmitters as required and as specified.
3. Provide an ONICON Model F-3500 Insertion Electromagnetic Flow Meter. Materials of construction for wetted metal components shall be 316 SS. For installations in non-metallic pipe, install grounding rings or probes. The flow meter shall average velocity readings from two sets of diametrically opposed electrodes. Each flow meter shall be individually wet-calibrated against a primary volumetric standard that is accurate to within 0.1% and traceable to NIST*. A certificate of calibration shall be provided with each flow meter. Accuracy shall be within $\pm 1\%$ of rate from 2-20 ft/s. Overall turndown shall exceed 100:1. Output signals shall be completely isolated and shall consist of the following: (1) high resolution frequency output for use with peripheral devices such as an ONICON display module or Btu meter, (1) analog output; 4-20mA, 0-10V, or 0-5V jumper selectable and (1) scalable dry contact output for totalization. Each flow meter shall be covered by the manufacturer's two-year warranty.

2.16 SPACE PRESSURE MONITORS

A. Room Pressure Module

1. The alarm monitor device shall have an LCD display which continuously scrolls and displays pressure direction, pressure magnitude and alarms, if any. The measured room pressure shall be continuously compared to the adjustable pressure set point. If the room pressure falls below or rises above this set point for more than an adjustable time delay, a red alarm light and an audible alarm on the monitor shall be activated. Alarm device shall also have a silence button to mute the audible alarm and a green light to indicate that room pressure is in the normal operating range. Alarming device shall be TSI Model RPM-20 or pre-approved equal.
2. Coordinate the model number / requirements for the associated pressure transducers with the owner and the facility standards.

2.17 AIRFLOW MEASURING STATIONS/DEVICES

A. Airflow/Temperature Measurement Device

1. Provide airflow/temperature measurement devices (ATMD) where specified and/or indicated on the plans.
2. Fan inlet measurement devices shall not be substituted for duct or plenum measurement devices unless an authorized EBTRON representative deems duct work to be too restrictive for probes. Written authorization is required by EBTRON and the specifying engineer.
3. Each ATMD shall consist of one (1) or more sensor probes and a single, remotely mounted, microprocessor-based transmitter capable of independently processing up to 16 independently wired sensor assemblies.
 - a. Each sensor assembly shall contain 2 individually wired, hermetically sealed bead-in-glass thermistors.
 - b. Thermistors shall be mounted in the sensor assembly using a marine-grade, waterproof epoxy. Thermistor leads shall be protected and not exposed to the environment.
 - c. The airflow rate of each sensor assembly shall be equally weighted and averaged by the transmitter prior to output.
 - d. The temperature of each sensor assembly shall be velocity weighted and averaged by the transmitter prior to output.
 - e. Each transmitter shall have a 16-character alpha-numeric display capable of displaying airflow, temperature, system status, configuration settings and diagnostics.
 - f. Devices using chip-in-glass or diode-case chip thermistors are not acceptable.
 - g. Devices using less than two (2) thermistors in each sensor assembly are not acceptable.
 - h. Devices using platinum wire RTDs are not acceptable.

- i. Devices having electronic circuitry mounted in or at the sensor probe are not acceptable.
 - j. Pitot tubes and arrays are not acceptable.
 - k. Vortex shedding devices are not acceptable.
4. All Sensor Probes
- a. Each sensor assembly shall independently determine the airflow rate and temperature at each measurement point.
 - b. Each sensor assembly shall be calibrated at a minimum of 16 airflow rates and 3 temperatures to standards that are traceable to the National Institute of Standards and Technology (NIST).
 - c. Airflow accuracy shall be $\pm 2\%$ of reading over the entire operating airflow range.
 - 1) Devices whose accuracy is the combined accuracy of the transmitter and sensor probes must demonstrate that the total accuracy meets the performance requirements of this specification throughout the measurement range.
 - d. Temperature accuracy shall be $\pm 0.15^\circ\text{F}$ over the entire operating temperature range of -20°F to 160°F .
 - e. The operating humidity range for each sensor probe shall be 0-99% RH (non-condensing).
 - f. Each sensor probe shall have an integral, U.L. listed, plenum rated cable and terminal plug for connection to the remotely mounted transmitter. All terminal plug interconnecting pins shall be gold plated.
 - g. Each sensor assembly shall not require matching to the transmitter in the field.
 - h. A single manufacturer shall provide both the airflow/temperature measuring probe(s) and transmitter for each measurement location.
5. Duct and Plenum Probes
- a. Probes shall be constructed of extruded, gold anodized, 6063 aluminum tube. All wires within the aluminum tube shall be Kynar coated.
 - b. Probe assembly mounting brackets shall be constructed of 304 stainless steel. Probe assemblies shall be mounted using 1 of the following options:
 - 1) Insertion mounted through the side or top of the duct.
 - 2) Internally mounted inside the duct or plenum.
 - 3) Standoff mounted inside the plenum.

- c. The number of sensor housings provided for each location shall be as follows:

Duct or Plenum Area (sq. ft)	Total # Sensors/Location
<2	4
>2 and <4	6
>4 and <8	8
>8 and <16	12
≥16	16

- d. The operating airflow range shall be 0 to 5,000 FPM unless otherwise indicated on the plans.

6. Fan Inlet Probes

- a. Sensor assemblies shall be mounted on 304 stainless steel housings.
- b. Mounting rods shall be field adjustable to fit the fan inlet and constructed of nickel plated steel.
- c. Mounting feet shall be constructed of 304 stainless steel.
- d. The operating airflow range shall be 0 to 10,000 FPM unless otherwise indicated on the plans.

7. Transmitters

- a. The transmitter shall have an integral LCD display capable of simultaneously displaying airflow and temperature. The LCD display shall be capable of displaying individual airflow and temperature readings of each independent sensor assembly.
- b. The transmitter shall be capable of field configuration and diagnostics using an on-board pushbutton interface and LCD display.
- c. The transmitter shall have a power switch and operate on 24 VAC (isolation not required).
- 1) The transmitter shall use a switching power supply fused and protected from transients and power surges.
- 2) The transmitter shall use "watch-dog" circuitry to assure reset after power disruption, transients and brown-outs.
- d. All interconnecting pins, headers and connections on the main circuit board, option cards and cable receptacles shall be gold plated.
- e. The operating temperature range for the transmitter shall be -20°F to 120°F. The transmitter shall be installed at a location that is protected from weather and water.

- f. The transmitter shall be capable of communicating with other devices using 1 of the following interface options:
 - 1) Linear analog output signals for airflow and temperature: Field selectable, fuse protected and isolated, 0-10 VDC/4-20 mA (4-wire).
 - 2) RS-485: Field selectable BACnet-ARCNET, BACnet-MS/TP, Modbus-RTU or Johnson Controls N2-Bus
 - a) BACnet devices shall provide analog variables for airflow and temperature containing individual sensor airflow rate and temperature data.
 - 3) 10 Base-T Ethernet: Field selectable BACnet Ethernet, BACnet-IP, Modbus-TCP and TCP/IP
 - a) Provide dynamic link libraries and VBA functions to interface Ethernet devices to Microsoft Excel for remote monitoring of airflow and temperature using a Windows 2000 or Windows XP based PC.
- g. The transmitter shall be capable of accepting an infra-red interface card for downloading airflow and temperature data or uploading transmitter configuration data using a handheld PDA (Palm or Microsoft Windows Mobile operating systems).
 - 1) Provide PDA upload/download software.
 - a) Download software shall be capable of displaying and saving individual sensor airflow rates, the average airflow rate, individual sensor temperatures and the average temperature received from the transmitter.
 - b) Upload software shall be capable of displaying and saving all setup parameters that can be configured using the on-board pushbutton interface and LCD display.
 - 2) Provide a Microsoft Excel file capable of creating balance reports from PDA data files transferred to a Windows 98 or higher based PC.
 - 3) Provide a Microsoft Excel file to create configuration data files that can be transferred from a Windows 2000, Windows XP or higher based PC to a PDA for upload to 1 or more transmitters.
- 8. The ATMD shall be UL listed as an entire assembly.
- 9. The manufacturer's authorized representative shall review and approve placement and operating airflow rates for each measurement location indicated on the plans.
 - a. A written report shall be submitted to the consulting mechanical engineer if any measurement locations do not meet the manufacturer's placement requirements.

10. Integral sleeve for outside air measurement:

- a. Provide an extruded aluminum (6063T5) sleeve. Sleeve depth shall be 15" for ducted applications and 18" for un-ducted applications. Unducted applications shall include a 3" radius aluminum entry flair. Provide an additional 7" (10" for ducted applications) between the downstream edge of an intake louver and the leading edge of the entry flair for outside air intake applications that are close coupled to intake louvers.

11. Provide Ebtron Model GTx116-P, GTx116-F or pre-approved equal.

2.18 AUTOMATIC CONTROL VALVES

A. All automatic control valves shall meet the following requirements:

1. Fully proportioning.
2. Capable of operating at varying rates of speed to correspond to the exact dictates of the controllers and variable load requirements.
3. Body pressure rating and connection type construction shall conform to piping and fittings in which the valve is to be installed and to the valve schedules.
4. Isolation valve shall be line size, full port ball valve with stainless steel ball and stem. Isolation valve 4" and larger shall be globe valves.
5. Control valves 2" and smaller shall have screwed connections.
6. Control valves larger than 2-1/2" shall have flanged connections.

B. Water Control Valves: Chilled water, hot water

1. Two-position valves shall be quick opening type with the following characteristics:
 - a. Valves shall have replaceable seat, plug, or disc.
 - b. Valves shall be line size.
 - c. Valve body shall be bronze, cast iron, forged brass, or red brass.
 - d. Ball valve shall have stainless steel stem, stainless steel ball, and PTFE seats.
 - e. Globe valve shall have stainless steel stem and single stainless steel seat.
 - f. The pressure drop shall not exceed 10-20% of the piping system pressure differential, leaving the other 80-90% for the load and piping connections.
 - g. Two-Way Valve

- 1) Valve actuator and trim shall provide close-off (differential) pressure ratings greater than or equal to 150% of the total system (pump) head.
2. Modulating control valves shall have the following characteristics:
 - a. Valve shall be one size below pipe size.
 - b. Valve shall have replaceable seat, plug, or disc.
 - c. Equal percentage flow characteristic (characterized ball or globe type valves).
 - d. Valve body shall be bronze, cast iron, forged brass or red brass.
 - e. Ball valve shall have stainless steel stem, stainless steel ball, and PTFE seats.
 - f. Globe valve shall have stainless steel stem and single stainless steel seat.
 - g. Two-Way Valve
 - 1) Calculate Cv based upon maximum design flow and a pressure drop equal to the pressure drop through the coil with a maximum of 5 psi (35 kPa).
 - 2) Valve actuator and trim shall provide close-off (differential) pressure ratings greater than or equal to 150% of the total system (pump) head.
- C. Steam Control Valves
 1. Control valves shall be globe type with linear flow characteristic.
 2. Valves shall have replaceable seat or plug.
 3. Valve body shall be bronze, cast iron, or brass.
 4. Globe valves shall have stainless steel stem, single stainless steel seat, and stainless steel plug.
 5. Sizing:
 - a. Two-position service: valve shall be line size with maximum pressure drop equal to 10-20% of inlet pressure (psig).
 - b. Modulating service at 15 psig (100 kPa) or less: Calculate Cv based upon maximum flow and pressure drop equal to 80% of inlet pressure (psig) or as required to provide design inlet pressure to coil.
 - c. Modulating service at 16-50 psig (101-350 kPa): Calculate Cv based upon maximum flow and pressure drop equal to 42% of inlet pressure (psig) or as required to provide design inlet pressure to coil.

- d. Modulating service at over 50 psig (350 kPa): Calculate Cv based upon maximum flow and pressure drop as scheduled on drawings or as required to provide design inlet pressure to coil.
 6. Close-off (differential) pressure rating: Valve actuator and trim shall provided minimum close-off pressure rating equal to 150% of operating (inlet) pressure.
 7. Whenever the steam flow rate requires a single valve larger than 2 ½", provide two (2) valves in parallel, sized for 1/3, 2/3 capacity, operating sequentially.
- D. Provide one (1) control valve for each preheat or heating coil at a minimum.
- E. Control valves shall be Belimo, Honeywell, Johnson Controls, Siemens or pre-approved equal.
- F. Control valves 4" and larger shall be globe valves.
- G. All valve actuators shall meet the following requirements:
1. All valve actuation shall be electric. Pneumatic actuation is not acceptable.
 2. Valve actuator shall be by same manufacturer as valve body unless pre-approved.
 3. Valve actuators shall:
 - a. Be quiet in operation.
 - b. Provide smooth modulation at design flow and pressure conditions.
 - c. Be capable of operating in sequence with other valves and/or damper actuators when required by the sequence of operation.
 - d. Be sized to close against a differential pressure equal to the design pump head plus 15%. Where pressure and flow combinations exceed ratings for commercial valves and actuators, industrial class valves and actuators shall be provided.
 - e. Valve actuators shall fail-safe in either the normally open or normally closed position in the event of power failure, signal failure or compressed air failure. Fail Safe positions are as follows:

1) Air-Handling Unit Preheat Valves	Fail Open
2) Air-Handling Unit Cooling Valves	Fail Closed
3) Air-Handling Unit Heating Valves	Fail Open
4) VAV Box Hot Water Rehear Valves	Fail-In-Place
5) All Humidification Valves	Fail Closed
6) Radiant Panel Valves	Fail Open

- | | | |
|----|------------------------------------------------|-------------|
| 7) | Cabinet Unit Heater Valves | Fail Closed |
| 8) | Heat Exchanger Steam Control Valves (1/3, 2/3) | Fail Closed |
| 9) | Isolation Valve | Fail Closed |
4. Incremental Electronic Actuator for Terminal Equipment Valve Actuation
- a. Incremental actuators shall be allowed for terminal equipment only.
 - b. Actuators shall be proportional, electronic, direct-coupled actuators used for modulating service. Actuators shall be equipped with metal housings and visual stroke indicators.
 - c. Actuators shall be equipped with a permanent manual adjustment.
 - d. Minimum Torque: 35" lb.
 - e. Operating Voltage: 24 VAC.
 - f. Input Signal: 3-wire floating, 0 – 10 VDC or 4 – 20 mA.
 - g. Frequency: 50 – 60 Hz.
 - h. Power Consumption: 1.5VA maximum.
 - i. Spring Return Time: 20 sec maximum.
 - j. Spring return position should be field adjustable with a switch.
 - k. Nominal Force: 90lb Minimum.
 - l. Stroke: 7/32" (5.5mm) maximum.
 - m. For use when the maximum media temperature is 230°F.
5. Electric Valve Actuation
- a. Actuator shall have electronic, proportional control and shall be direct-coupled with spring return.
 - b. Actuators shall be equipped with a permanent manual override hand wheel and visual and electronic stroke indicators.
 - c. Operating Voltage: 24 VAC.
 - d. Input Signal: 0-10 VDC, 4 – 20 mA.
 - e. Power Consumption: 18VA maximum (valves 2" and under), 28VA maximum (valves 2-1/2" – 4")
 - f. Spring Return Time: 15 seconds maximum
 - g. Spring return position should be field adjustable with a switch.

- h. Nominal Force: 225lb Minimum (valves 2" and under), 610lb. (valves 2-1/2"-4")
- i. Stroke: 3/4" (20mm) maximum (valves 2" and under), 1-1/2" (valves 2-1/2"-4")
- j. For use when the maximum media temperature is 300°F.

2.19 DAMPER ACTUATION

- A. All damper actuation shall be electric. Pneumatic actuation is not acceptable.
- B. Damper actuators used for emergency generator intake or exhaust applications shall be fast-acting type.
- C. Size actuators for running torque calculated as follows:
 - 1. Parallel-Blade Damper with Edge Seals: 7"-lb/sq. ft. (86.8 kg-cm/sq. m) of damper.
 - 2. Opposed-Blade Damper with Edge Seals: 5"-lb/sq. ft. (62 kg-cm/sq. m) of damper.
 - 3. Parallel-Blade Damper without Edge Seals: 4"-lb/sq. ft (49.6 kg-cm/sq. m) of damper.
 - 4. Opposed-Blade Damper without Edge Seals: 3"-lb/sq. ft. (37.2 kg-cm/sq. m) of damper.
 - 5. Dampers with 2" to 3" wg (500 to 750 Pa) of Pressure Drop or Face Velocities of 1000 to 2500 fpm (5 to 13 m/s): Increase running torque by 1.5.
 - 6. Dampers with 3" to 4" wg (750 to 1000 Pa) of Pressure Drop or Face Velocities of 2500 to 3000 fpm (13 to 15 m/s): Increase running torque by 2.0.
- D. All damper actuators shall meet the following requirements:
 - 1. Damper actuators shall have external adjustable stops to limit the stroke in either direction.
 - 2. All damper actuators shall have sufficient power to overcome friction of damper linkage and air pressure acting on louvers and to operate the damper smoothly throughout the entire damper range.
 - 3. Actuators shall be sized with a torque greater than 150% of the design damper torque.
 - 4. Actuators shall have mounting arrangement for location outside of the air stream. The damper actuators shall be mounted on the damper extension so that it is not buried in the wall construction.
 - 5. Damper actuators shall fail-safe in either the normally open or normally closed position in the event of power failure, signal failure or compressed air failure. Fail Safe Positions are as follows:

- a. Outside Air Dampers Normally Closed
 - b. Return Air Dampers Normally Open
 - c. Exhaust Air Dampers Normally Closed
 - d. Isolation Dampers Normally Closed
6. Incremental Electronic Actuator for Terminal Equipment Damper Actuation
- a. Incremental actuators shall be allowed for terminal equipment only.
 - b. Actuators shall be proportional, electronic, direct-coupled actuators used for modulating service. Actuators shall be equipped with metal housings and visual stroke indicators.
 - c. Actuators shall be equipped with a permanent manual adjustment.
 - d. Minimum Torque: 35" lb.
 - e. Operating Voltage: 24 VAC.
 - f. Input Signal: 3 wire floating, 0 – 10 VDC, or 4 – 20 mA.
 - g. Frequency: 50 – 60 Hz.
 - h. Power Consumption: 1.5VA maximum.
 - i. Spring Return Time: 20sec maximum.
 - j. Spring return position should be field adjustable with a switch.
 - k. Nominal Force: 90lb Minimum.
 - l. Stroke: 7/32" (5.5mm) maximum.
 - m. For use when the maximum media temperature is 230°F.
7. Electric Damper Actuation
- a. Provide proportional, electronic, direct-coupled spring return actuators for all automatic dampers used for modulating service. Each actuator shall be equipped with a brushless DC motor, self centering shaft coupling, metal housing, permanent manual override, visual stroke indicators and built in adjustable start and span controls with the following specifications:
 - 1) Operating Voltage: 24 VAC./ 120 VAC (Hardwired to starter circuit)
 - 2) Input Signal: 0-10 VDC, 4 – 20 mA (modulating), on/off (2 position).
 - 3) Frequency: 50 – 60 Hz.
 - 4) Power Consumption: 9 VA Maximum.

- 5) Spring Return Time: 15 seconds Maximum.
- 6) Spring return position should be field adjustable with a switch.
- 7) Minimum Torque: 133" lb.
- 8) Angular Rotation: 90°.

E. Damper actuators shall be Belimo or pre-approved equal.

2.20 SMOKE PURGE PANEL

A. General:

1. This specification defines the basic construction and components for a Firefighter's Override Control Panel. The control panel shall be a graphic display with switches and LED indicators. The control panel shall be mounted on a surface mounted enclosure.
2. Construction:
 - a. The control panel shall be constructed with a .125-inch aluminum substrate and a 7-mil polyester film overlay. The polyester film overlay shall be protected by a non-glare textured coating, which is non-yellowing, durable, and scratch resistant. LEDs, resistors, diodes, etc. shall be mounted on printed circuit boards (PCBs). All wiring to the PCBs shall be made on solder type terminal turrets. All switches shall be securely mounted to the panel.

B. Graphic - Graphic Colors:

1. The film overlay shall be a graphic as shown in the architect's plan with black lines and legends, and colored background areas. The graphic shall be made of 7-mil photographic film, having all accent colors applied to the backside of the film. Important areas such as elevator shafts, stairwells, and main air ducts shall be highlighted for easy identification. The panel supplier shall furnish a color chart with a minimum of 22 accent colors for architect selection.

C. Graphic Surface:

1. The working surface (polyester film) shall be bonded to the aluminum substrate with an adhesive that has been proven not to delaminate in similar applications. The adhesive shall achieve 100% bonding without any creases, bumps, or blemishes in the working surface (face) of the graphic. The working surface (face) of the graphic shall be textured and non-glare. Translucent areas shall be made in the overlay for backlighted indicators. LEDs shall not protrude through the polyester film overlay. Backlit areas shall be subdued until the LED is illuminated. The illumination of any indicator shall be clearly visible from any viewing angle in front of the working surface of the graphic.

D. Substrate:

1. The aluminum substrate shall have holes for LEDs and switches. The substrate shall have holes drilled and tapped for mounting the printed circuit boards. The aluminum substrate shall have a clear irradiated finish to prevent oxidation.

E. Indicators:

1. The indicators shall be high intensity LEDs, T-1 $\frac{3}{4}$ in size, and rated for normal operation at a current of 20 mA. The LEDs shall have an operating life of a minimum of 170,000 hours of continuous or pulsed operation. The LED lens body shall be constructed of high impact plastic. All LEDs shall be mounted on .062" printed circuit boards constructed of epoxy glass material, NEMA Type FR-4, Grade 10. Resistors and diodes for current limiting and LED test shall also be mounted on the printed circuit boards. Solder type, pressed in turrets shall be provided for electrical connections to the LEDs. All field wiring shall terminate on modular screw clamp type terminals or connectors located in the rear of the enclosure.

F. Switches:

1. Rotary switches shall be used for specific panel operations unless other switch types are specified. A key switch shall be used for panel enable operation when specified. Switches shall be rated for the load served. A momentary pushbutton shall be provided for simultaneous testing of all LEDs. All switch wiring shall be terminated on modular screw clamp type terminal strips or connectors mounted in the rear of the enclosure.

G. Enclosure:

1. The enclosure shall be made from cold rolled steel and be assembled using all welded and formed steel construction. The enclosure shall be primed and painted with a baked enamel and have a textured finish. A security door with viewing window may be supplied to prevent unauthorized operation of the control panel switches. All enclosures shall be constructed according to UL 864 Section 7 specifications.

PART 3 - EXECUTION

3.1 INSTALLATION

- A. Install software in control units and operator workstation(s). Implement all features of programs to specified requirements and as appropriate to sequence of operation.
- B. Connect and configure equipment and software to achieve sequence of operation specified.
- C. All control components including automatic control valves, dampers, instruments, sensors, etc shall be tagged for identification. Acceptable methods of tagging are: laminated plastic, stamped metal and engraved plastic.
- D. Install equipment level and plumb.

- E. Verify location of temperature sensors, humidity sensors and other exposed control sensors with plans and room details before installation. Locate all 60" above the floor or as otherwise required by ADA.
 - 1. Install averaging elements in ducts and plenums in crossing or zigzag pattern.
 - F. Install guards on thermostats in the following locations:
 - 1. Entrances.
 - 2. Public areas.
 - 3. Where indicated.
 - G. Install damper motors on outside of duct in warm areas, not in locations exposed to outdoor temperatures.
 - H. Install automatic dampers according to Division 23 Section.
 - I. Install hydronic instrument wells, valves and other accessories according to Division 23.
 - J. Install refrigerant instrument wells, valves and other accessories according to Division 23.
 - K. Install duct volume-control dampers according to Division 23.
 - L. Install electronic cables according to Division 26.
 - M. Water line mounted sensors shall be removable without shutting down the system in which they are installed.
 - N. For duct static pressure sensors, the high pressure port shall be connected to a metal static pressure probe inserted into the duct pointing upstream. The low pressure port shall be left open to the plenum area at the point that the high pressure port is tapped into the ductwork.
 - O. Averaging temperature sensors (i.e. freezestats, mixed air temperature sensor, etc.) shall be provided with fasteners or mounting clips to prevent shearing due to vibrations in the ductwork.
- 3.2 ELECTRICAL WIRING AND CONNECTION INSTALLATION
- A. Install, connect and wire the items included under this Section. This work includes providing required conduit, wire, fittings and related wiring accessories.
 - B. All exposed wiring and wiring in mechanical equipment rooms shall be installed in conduit.
 - C. Plenum rated cable shall be acceptable in hung ceilings, walls and raised floors.
 - D. All wiring located outside shall be installed in rigid conduit, seal tite or EMT with compression fittings.
 - E. Conceal cable, except in mechanical rooms and areas where other conduit and piping are exposed.

- F. Install cable in raceway.
- G. Bundle and harness multiconductor instrument cable in place of single cables where several cables follow a common path.
- H. Fasten flexible conductors, bridging cabinets and doors, along hinge side; protect against abrasion. Tie and support conductors.
- I. Number-code or color-code conductors for future identification and service of control system, except local individual room control cables.
- J. Wires and cables shall be as follows:
 - 1. Single Conductor (120 VAC): Type THWN 12AWG stranded copper with 600V insulation.
- K. Primary and Secondary Communications Network Cabling
 - 1. Primary network shall be Ethernet based and shall utilize CAT5, CAT6 or fiber optic cable. All wiring runs longer than 300' shall utilize fiber optic cable.
 - 2. Cable shall be of type recommend by the DDC System Manufacturer and 20AWG at a minimum.
 - 3. Cable shall be shielded.
 - 4. Multimode OM4, 50/125-micrometer, 12-fiber at a minimum (or per design), armored, tight buffer, laser-optimized optical fiber cable. Shall comply with TIA/EIA-568-B.3 for performance specifications. Shall be listed by NRTL as compliant with UL 444, UL 1651, and NFPA 70 as OFNR or OFNP. Maximum attenuation 3.5 dB/km at 850 nm; 1.5 dB/km at 1300 nm. Minimal modal bandwidth 160 MHz-km at 850 nm; 500 MHz-km at 1300 nm. Aqua colored jacket. Provide 100% spare capacity. Industry standard ST style connectors shall be used, with a hot melt or glue and polish termination. Use of mechanical crimp type connectors is not acceptable.
- L. Room Sensor Cabling
 - 1. Cable shall consist of copper conductors not less than No. 24 AWG.
- M. Cables for 120 VAC wiring and low level signal wiring (i.e., 4 – 20 mA analog) shall always be run in separate raceways.

3.3 CONNECTIONS

- A. Connect manual-reset limit controls independent of manual-control switch positions. Automatic duct heater resets may be connected in interlock circuit of power controllers.
- B. Connect HOA selector switches to override automatic interlock controls when switch is in hand position.
- C. Ground equipment.

3.4 FIELD QUALITY CONTROL

- A. Manufacturer's Field Service: Engage a factory-authorized service representative to inspect field-assembled components and equipment installation, including piping and electrical connections. Report results in writing.
 - 1. Operational Test: After electrical circuitry has been energized, start units to confirm proper unit operation. Remove malfunctioning units, replace with new units and retest.
 - 2. Test and adjust controls and safeties.
- B. Engage a factory-authorized service representative to perform startup service.
- C. Replace damaged or malfunctioning controls and equipment.
 - 1. Start, test and adjust control systems.
 - 2. Demonstrate compliance with requirements, including calibration and testing and control sequences.
 - 3. Adjust, calibrate and fine tune circuits and equipment to achieve sequence of operation specified.
- D. Verification
 - 1. Verify that instruments are installed before calibration, testing and loop or leak checks.
 - 2. Check instruments for proper location and accessibility.
 - 3. Check instrument installation for direction of flow, elevation, orientation, insertion depth and other applicable considerations.
 - 4. Check instrument tubing for proper fittings, slope, material and support.
 - 5. Check installation of air supply for each instrument.
 - 6. Check flow instruments. Inspect tag number and line and bore size and verify that inlet side is identified and that meters are installed correctly.
 - 7. Check pressure instruments, piping slope, installation of valve manifold and self-contained pressure regulators.
 - 8. Check temperature instruments and material and length of sensing elements.
 - 9. Check control valves. Verify that they are in correct direction.
 - 10. Check air-operated dampers. Verify that pressure gages are provided and that proper blade alignment, either parallel or opposed, has been provided.
 - 11. Check DDC system as follows:
 - a. Verify that DDC controller power supply is from emergency power supply, if applicable.

- b. Verify that wires at control panels are tagged with their service designation and approved tagging system.
- c. Verify that spare I/O capacity has been provided.
- d. Verify that DDC controllers are protected from power supply surges.

3.5 COMMISSIONING

- A. Prior to full operation, the contractor in the presence of the owner's representative and engineer shall perform a complete demonstration and testing of the system operating functions and alarms. This testing shall take place after having satisfactorily met the requirements of shop drawing acceptance. Upon successful completion of system operation, the contractor shall submit a statement in writing stating that the full operation of all systems, functions and alarms has been demonstrated and are operational as well as a listing of all systems, alarms and functions that have been commissioned. All items shall be submitted for review and acceptance to the owner, owner's representative and engineer before final acceptance can take place.

3.6 DEMONSTRATION

- A. Engage a factory-authorized service representative to train Owner's maintenance personnel to adjust, operate and maintain HVAC instrumentation and controls. Refer to Division 1 Section "Closeout Procedures" and "Demonstration and Training."

3.7 TRAINING

- A. The BMS contractor shall provide competent instructors to give full instruction to designated personnel in the adjustment, operation and maintenance of the system installed rather than a general training course. Instructors shall be thoroughly familiar with all aspects of the subject matter they are to teach. All training shall be held during normal work hours of 8:00 a.m. to 4:30 p.m. weekdays.
- B. Provide eight (8) hrs of training for Owner's operating and maintenance personnel. All training shall be on-site training. Videotape all sessions and edit each session to 1-hour DVDs. Turn over two (2) copies each unedited and edited DVD to the Owner. Training shall include:
 - 1. Explanation of drawings, operators and maintenance manuals.
 - 2. Walk-through of the job to locate all control components.
 - 3. Operator workstation and peripherals.
 - 4. DDC Controller operation/function.
 - 5. Operator control functions including graphic generation, if design includes color graphics and field panel programming.
 - 6. Explanation of adjustment, calibration and replacement procedures.
- C. The BMS contractor shall also create a color PDF reference guide for the use of the Owner and the operating staff which provide graphical step-by-step instructions on

how to perform basic tasks at the BMS that are part of the owner's operating staff's daily duties. This shall include, but not be limited to, navigating the BMS screens, setpoint adjustment, turning units on/off, turning systems on/off, overriding commands, acknowledging alarms, adjusting time schedules, etc. Coordinate with the Owner's operating staff as required.

- D. Since the Owner may require personnel to have more comprehensive understanding of the hardware and software, additional training must be available from the Contractor. If the Owner requires such training, it will be contracted at a later date. Provide description of available local and factory customer training. Provide costs associated with performing training at an off-site classroom facility and detail what is included in the manufacturer's standard pricing such as transportation, meals, etc.
- E. The BMS Contractor shall provide phase training to ensure that when the new BMS workstation is installed, the facility staff are able to utilize the new workstation/software as equipment is switched over from the existing BMS to the new BMS. Below is a timeline of how to phase the training schedule:
 - 1. After cut-over of first system to the new BMS:
 - a. Familiarize the owner and their operating staff with the new BMS workstation, BMS software and how an overview of operator control functions including but not limited to:
 - 1) Navigating the new BMS software screens
 - 2) Setpoint adjustment
 - 3) Alarm notifications and acknowledgment
 - 4) Adjusting the occupancy schedule
 - 5) Overriding commands and setpoints
 - b. Familiarize the Owner and the Owner's operating staff with the new DDC controllers and their functions
 - c. Provide a simple navigation and basic operator control function tutorial in color in PDF for easy reference for the owner and the operating staff. The tutorial shall include how to access data and complete all operator control functions required for the owner's operating staff to perform their duties.
 - 2. After the major hydronic systems (chiller plant, hot water system) have been cut over:
 - a. Provide a more detailed version of the training that occurred after the cut-over of the first system.
 - b. Familiarize the Owner and the Owner's operating staff with the new DDC controllers and their functions
 - c. Update the navigation and basic operator control function as necessary

3. At the conclusion of the project, the BMS contractor shall provide a formal training that includes all items listed in this section along with any items recommended by the manufacturer of the BMS software/hardware. Update the navigation and basic operator control function as necessary.
4. The BMS Contractor shall also include training to be provided before the first heating season and before the first cooling season to assist the Owner's operating staff with switch-over of equipment and systems. This training shall be scheduled with the owner.

3.8 ON-SITE ASSISTANCE

- A. Occupancy Adjustments: Within 1 year of date of Substantial Completion, provide up to three (3) Project-site visits, when requested by Owner, to adjust and calibrate components and to assist Owner's personnel in making program changes and in adjusting sensors and controls to suit actual conditions.

3.9 RECORD DOCUMENTATION

A. Operation and Maintenance Manuals

1. Three (3) copies of the Operation and Maintenance Manuals shall be provided to the Owner's Representative upon completion of the project. The entire Operation and Maintenance Manual shall be furnished on Compact Disc media and include the following for the BMS provided:
 - a. Table of contents.
 - b. As-built system record drawings. Record drawings shall represent the as-built condition of the system and incorporate all information supplied with the approved submittal.
 - 1) BMS network riser diagram
 - 2) Wiring diagrams
 - 3) Electrical drawings
 - 4) Flow diagrams and device locations
 - 5) Hardware and software points list
 - 6) Bill of materials
 - 7) Sequence of operations.
 - 8) I/O point lists
 - 9) Cut sheets of all equipment installed
 - c. Manufacturer's product data sheets or catalog pages for all products including software.
 - d. System Operator's manuals.
 - e. Archive copy of all site-specific databases and sequences.

- f. BMS network diagrams.
 - g. Interfaces to all third-party products and work by other trades.
 - h. Training course list.
- B. The Operation and Maintenance Manual CD shall be self-contained and include all necessary software required to access the product data sheets. A logically organized table of contents shall provide dynamic links to view and print all product data sheets. Viewer software shall provide the ability to display, zoom and search all documents.

END OF SECTION

This page is intentionally left blank.

SECTION 230993

SEQUENCE OF OPERATIONS

PART 1 - GENERAL

1.1 RELATED DOCUMENTS

- A. Drawings and general provisions of the Contract, including General and Supplementary Conditions and Division 1 Specification Sections, apply to this Section.
- B. Section 01 81 13 "Sustainable Design Requirements – LEED v4 for Building Design & Construction – New Construction" for sustainable design requirements and detailed sustainable design submittal requirements.
- C. Section 01 74 19 "Construction and Demolition Waste Management and Disposal" for disposal of construction, demolition and packaging waste disposal requirements.

1.2 SUMMARY

- A. This Section includes control sequences for HVAC systems, subsystems and equipment.
- B. Sustainable Building Requirements:
 - 1. The Owner requires the Contractor to implement practices and procedures to meet the project's environmental performance goals, which include achieving LEED version 4 **Certified** level Certification. Specific project goals that may impact this area of work include: use of recycled-content materials; use of locally-manufactured materials; use of low-emitting materials; construction waste recycling; and the implementation of a construction indoor air quality management plan. The Contractor shall ensure that the requirements related to these goals, as defined in the Articles below, are implemented to the fullest extent. Substitutions, or other changes to the work proposed by the Contractor or their Subcontractors, shall not be allowed if such changes compromise the aforementioned environmental goals and LEED certification.

1.3 DEFINITIONS

- A. AHU: Air Handling Unit.
- B. AI: Analog Input.
- C. AO: Analog output.
- D. ATC: Automatic Temperature Control.
- E. BMS: Building Management System.
- F. CFM: Cubic Feet per Minute.
- G. DDC: Direct-digital controls.
- H. DI: Digital Input.

- I. DO: Digital Output.
- J. FAS: Fire Alarm System.
- K. HVAC: Heating, Ventilating and Air Conditioning.
- L. LAN: Local area network.
- M. LCD: Liquid Crystal Display
- N. MER: Mechanical Equipment Room.
- O. PID: Proportional Integral Derivative.
- P. POT: Portable Operators Terminal.
- Q. RTU: Rooftop Air Handling unit.
- R. VAV: Variable air volume.
- S. VFD: Variable Frequency Drive.

1.4 GENERAL

- A. All safety devices shall be hardwired to the starter and shall have a second contact for monitoring via the BMS.
- B. A failure alarm, as included in the point list, shall indicate the type of equipment that has failed (pump, fan, valve, etc.) including the specific designation of the piece of equipment (e.g., supply fan SF-1). It is not acceptable to generate a general failure alarm.
- C. Alarming devices such as pressure safeties, etc. shall be wired so the contacts open in the alarm condition. All alarm points shall be annunciated at the BMS audibly and visually. All alarm points associated with varying values shall be provided with adjustable limits.
- D. Air pressure switches shall be manual reset type and a manual reset at the switch shall be required to allow the system to restart.
- E. All setpoints including setpoints internal to control algorithms shall be adjustable from all BMS operator interfaces. All commands shall be overrideable from all BMS operator interfaces. All control points shall be adjustable or overrideable from the same graphic page that displays the points.
- F. All points for a specific mechanical system shall be connected to and controlled by the same DDC controller unless otherwise specified. For example, it is not acceptable to control a supply fan with one (1) DDC controller located at a motor control center and to control the rest of the air-handling unit points with a DDC controller located at the air-handling unit.
- G. All points required by the sequence of operation including, but not limited to, the points listed in the sequences of operation below, as well as all of the points' associated values, shall be connected to the BMS and available to the BMS operators on all operator workstations and all operator interface devices as part of a graphical display that depicts the mechanical system controlled.
- H. The BMS shall utilize the building LAN (MMC IT backbone) as the primary network. Ethernet drops shall be provided by others as required. Coordinate exact locations of all Ethernet drops. The BMS contractor is responsible for all other wiring,

devices, etc. required to connect to the LAN. The BMS contractor shall coordinate with MMC IT for all network tie-in requirements.

- I. All valves, dampers, controllers, control devices, etc. exposed to outside air conditions shall be specifically designed for outside air conditions including, but not limited to, NEMA 4X enclosures, weatherproof enclosures and all other weather precautions recommended by the manufacturer.
- J. No part of the programming specified herein shall be programmed into operator priority.
- K. All alarms associated with equipment that is disabled shall be inhibited.
- L. All initial field settings applied shall be saved as the default values. These values shall be downloaded to the controller such that they are the default value if the controller loses power. A printed copy shall also be provided to the owner as part of the O & M manuals.
- M. When the motor controller is equipped with an HOA, the motors shall only be controlled by the BMS when the HOA switch is in the auto position.
- N. Steam condensate sensors, pressure safeties, interlocked dampers, etc. shall be wired to shutdown motors when the HOA switch is in both the hand and auto positions. It shall not be possible to override these or any other safety devices or any fire alarm system control functions, except in the case of an engineered smoke control system in which case freeze protection safeties shall be overridden.
- O. Where fans and dampers are to be hardwire interlocked, provide hardwire interlocks between the motor terminal strip and dampers such that the damper shall be driven open then the motor is required to start. Motor start-up shall not occur until the damper end switch indicates the damper is in the full open position. Where fans and dampers are hardwire interlocked, the interlocks shall apply in both the "hand" and "auto" positions of the HOA switch at the motor controller.
- P. The point lists are provided for convenience and are not intended to be all-inclusive. All points required to provide the Sequence of Operation shall be included as if listed.

1.5 TIE-IN TO EXISTING BMS

- A. Provide a SEAMLESS tie-in to the existing BMS. The tie-in shall include Direct Digital Control (DDC), historical data collection, archiving and alarm, energy and information management for all control points specified herein.
- B. Tie-in to existing site BMS of all DDC equipment and points as specified in this section and as required in all other referenced sections and as required to complete the sequences of operation outlined herein. Tie-in shall be made via an extension of the existing BMS.
- C. Provide new color graphics for all new systems specified in this contract. MMC HVAC supervisor shall sign off on all changes to the BMS graphics.
- D. Revisions to all existing BMS workstations as required to incorporate the additional control components provided under this section. Revisions shall include, but are not limited to, revised graphics, update of additional firmware and/or software as required to accommodate new points.

1.6 VARIABLE AIR VOLUME RECIRCULATING ROOFTOP UNITS (AHU-149 & AHU-150)

A. Safeties

1. The supply and/or return smoke detector shall stop the supply and return fans upon the presence of smoke through the FAS.
2. A low suction air pressure switch located upstream of the supply fan array and downstream of the closest damper shall stop the supply and return fans when duct pressure decreases below an adjustable setpoint. A high discharge air pressure switch located downstream of the supply fan array and upstream of the closest damper shall stop the supply and return fans when duct pressure exceeds an adjustable setpoint. The supply and return fans shall remain off until the air pressure switch is manually reset.
3. A low suction air pressure switch located upstream of the return fan array and downstream of the closest damper shall stop the supply and return fans when duct pressure decreases below an adjustable setpoint. A high discharge air pressure switch located downstream of the return fan array and upstream of the closest damper shall stop the supply and return fans when duct pressure exceeds an adjustable setpoint. The supply and return fans shall remain off until the air pressure switch is manually reset.

B. Occupied Mode

1. The rooftop unit shall be started based upon a time of day schedule or manual command and run continuously. The rooftop unit shall be programmed to run 24 hours a day, 7 days a week.
2. All associated VAV boxes and fan powered boxes shall be enabled prior to the supply fan array starting.
3. Upon a command to start, the BMS shall send a signal to the fire alarm system to open associated fire/smoke dampers at the shafts. Once the FAS confirms the associated fire/smoke dampers open, the AHU shall be allowed to start. Hardwired damper end switches on all 2-position dampers shall energize the supply and return fan array VFDs when all associated dampers are in their fully open position.
4. Totalize current airflow rate from VAV boxes and display on AHU graphic at discharge duct. Display the AFMS airflow rate adjacent to the sum-of-zone airflow rate. The airflow measurement stations are to be used for control.
5. The AHU shall poll the VAVs it serves over the controls network to obtain each of its VAVs damper positions.
6. Rooftop Unit Damper Control
 - a. During occupied mode, the return air damper and exhaust air damper shall modulate open and the maximum outside air damper shall remain closed. The minimum outside air damper shall modulate to maintain minimum outdoor air setpoint as sensed by the minimum outdoor air flow monitoring station. If the minimum outside air damper is open 100% and the minimum outside air CFM requirement is not met, the return air dampers shall modulate close as necessary to maintain the minimum outdoor air CFM setpoint.

- b. During economizer mode, the exhaust air damper shall stay open, the maximum outside air damper shall modulate open, the return air damper shall modulate closed 120 seconds (adj.) after the maximum outside air damper is commanded open, and the minimum outside air CFM control loop shall be disabled.

7. Supply and Return Fan Control

- a. The controls will be programmed to maintain the minimal fan speed required to satisfy the boxes under the following criteria:

- 1) Note: there may exist a few rouge boxes in a system. These are boxes that, given normal building operating conditions, may consistently stay unsatisfied due to the upstream AHU reaching a stabilized state required to satisfy the majority of the VAVs.

- a) Rouge zones shall be given an importance multiplier of zero (0).

- 2) If any VAV dampers are less than 80% (adj.) open, then the duct static pressure setpoint shall be reduced by 0.05 inches every 5 minutes. This reduction will occur until at least one of the boxes has opened its damper greater than the aforementioned 80% (adj.) variable.

- 3) If a minimum of 2(adj.) VAV dampers have modulated to a position of 95% (adj.) or greater, then the duct static pressure setpoint shall be increased by 0.1 inches Every 2 minutes.

- 4) Alternatively, the static pressure setpoint may be reset with a properly tuned PID control algorithm.

- 5) If the supply fan VFD has been at full speed (100% or 60hz) for more than 5 minutes (adj.) and any VAV included in the calculation is at 100% open during the same 5 Minutes, a level 4 alarm shall be issued.

- 6) Upon a total loss of communications between the VFD and the VAVs, the supply fan speed shall operate at the current value until communications are restored.

- b. There shall be one (1) variable frequency drive per supply fan in the supply fan array and one (1) variable frequency drive per return fan in the return fan array. Supply and return fan array variable frequency drives shall start unloaded and slowly ramp up to speed as required. In the occupied mode, the supply and return fans run continuously. The supply fans in the supply fan array shall each modulate in unison. The return fans in the return fan array shall each modulate in unison. The supply fan array variable frequency drives shall be controlled to maintain the supply static pressure setpoint, as sensed at a point 3/4 downstream of the supply fan array. The return fan array variable frequency drives shall be controlled to maintain the return CFM, as sensed by a return airflow measuring station, at the return CFM setpoint. The return CFM setpoint shall be calculated by subtracting

[exhaust air and air flow required for pressurization)] from the supply CFM, as sensed by a supply airflow measuring station.

RA = SA - (EA + Qp) where,

- 1) RA = Return airflow setpoint.
 - 2) SA = Supply airflow as measured by airflow measuring station.
 - 3) EA = Total exhaust airflow from the area served by the RTU. (Coordinate with the air balancer and mechanical plans).
 - 4) Qp = Outdoor air required to maintain building pressurization. (use 10% of the RTU design CFM if this value is not given).
8. Economizer mode shall be available whenever the outside air enthalpy is less than the rooftop unit return air enthalpy and the outside air relative humidity is less than 80% (adj.). If economizer is available and there is a rise in supply air temperature above the supply air temperature setpoint, the maximum outside air damper shall modulate open to 100%. There shall be a 120 second (adj.) time delay to close the return damper after the maximum outside air damper is commanded open. If the maximum outside air damper is open 100% and there is a further rise in the supply air temperature above setpoint, the outside air damper shall remain 100% open, and the chilled water valve shall modulate open as necessary to maintain the supply air temperature setpoint.
9. When economizer mode is not available, the chilled water valve and steam valve shall modulate in sequence as necessary to maintain the supply air temperature setpoint. The minimum outside air damper shall modulate to maintain minimum fresh air CFM setpoint. The return air damper shall open 100%.

C. Supply Air Temperature Setpoint Control

1. Coordinate all temperature reset sequences with MMC Controls standards.
2. Control loop shall enable only when the supply air fan is proven on.
3. Supply air temperature set point
 - a. Setpoint shall be reset between supply air temperature setpoint minimum (sat-min) and supply air temperature setpoint maximum (sat-max) based on heating and cooling calls from the downstream VAVs.
 - 1) Sat-min shall be a user adjustable value, limited to a maximum of 60°F. Initial value for all AHUs shall be 53°F.
 - 2) Sat-max shall be a user adjustable value limited to a minimum of 70°F and a maximum of 85°F. Initial value for all AHUs shall be 75°F.
 - 3) Supply air temperature shall be reset using heating and cooling request and response. A PID will handle the response portion to the summed heating and cooling requests where:

- a) Heating and cooling requests cancel each other out. For example, all heating requests shall be negative and all cooling requests shall be positive.
 - b) Heating and cooling requests shall be summed from all associated zones.
 - c) The result of the summation shall then be used as the input of a PID with a fixed setpoint of zero. This result may be multiplied by 10 or 100 if required by the specific PID being used. The PID shall be configured in such a way that the loop will output 50% when its input is equal to set point (or PID bias will equal 50%).
 - d) The result of the PID shall then be used as the input of a linear reset. This reset shall use the PID's output range (0-100) to reset the supply air temperature set point between sat-min and sat-max. The calculated supply air temperature set point shall be able to be overridden at the user interface.
- b. During warm-up mode, supply air setpoint shall be 70°F and VAVs with reheats shall open reheats 100% until space heating set point is satisfied.
 - c. During unoccupied mode setpoint shall be calculated per heating/cooling requests as defined above.
- D. Humidification
1. When the outdoor air temperature is less than 65°F (adj.), the humidifier shall be enabled. The humidifier control valve shall modulate as necessary to maintain the return air relative humidity setpoint of 35% RH (adj.). As the return air relative humidity drops below setpoint, the humidifier valve shall modulate open. As the return air relative humidity rises above the setpoint, the humidifier valve shall modulate close.
 2. A supply air humidity high limit control algorithm shall override the humidifier valve close to maintain a high limit of 75% RH (adj.) as sensed by a humidity sensor located downstream of the humidifier. The humidifier valve shall not be fully closed upon reaching the high limit setpoint. A humidity high limit switch shall shut down the humidifier if the supply air humidity rises above the high limit setpoint (adj.). The humidity high limit switch shall be provided by the humidifier manufacturer.
- E. Mixed air temperature low limit control: The outside air, return air, and exhaust air dampers shall be overridden as necessary to maintain the mixed air low limit setpoint of 45°F (adj.).
- F. Preheat Valve Control and Freeze Protection
1. If the heating coil condensate temperature sensor drops below 45°F (adj.), the steam control valve shall modulate open to maintain the steam condensate temperature at 45°F (adj.).

2. Upon a freezestat sensing a temperature below 40°F (adj.), the supply and return fans shall disable and the outside air dampers shall close. The steam control valve shall modulate to maintain the preheat discharge air temperature of 90°F, and set an alarm to the BMS indicating the unit is shut down by freeze protection.
 - a. If a freeze protection shutdown is triggered, it shall remain in effect until it is reset by a physical reset switch. There shall be no software reset switches allowed.

G. Unoccupied Mode

1. The supply and return fans shall remain off and the variable frequency drives shall be set to 0%. The return air damper shall open and the outside air and return air dampers shall close. All isolation dampers shall close and the BMS shall send a signal to the fire alarm system to close the associated fire/smoke dampers at the shafts. The chilled water valve shall close and the steam valve shall modulate as necessary to maintain the steam condensate temperature of 45°F (adj.). The humidifier control valve shall remain closed.

H. Provide the following points hardwired to the BMS:

1. All points available via integration (BACNet, Modbus) to each VFD
2. AI – Final-filter differential pressure (via differential pressure transmitter).
3. AI – Mixed air temperature.
4. AI – Outside air CFM.
5. AI – Pre-filter differential pressure (via differential pressure transmitter).
6. AI – Preheat coil discharge air temperature.
7. AI – Return air CFM.
8. AI – Return air humidity.
9. AI – Return air temperature.
10. AI – Return fan VFD speed feedback (0-100%; one (1) per VFD).
11. AI – Steam Condensate temperature.
12. AI – Supply air CFM.
13. AI – Supply air humidity.
14. AI – Supply air static pressure.
15. AI – Supply air temperature.
16. AI – Supply fan VFD speed feedback (0-100%; one (1) per VFD).
17. AO – Chilled water valve control (0-100%).
18. AO – Humidifier valve control (0-100%).
19. AO – Outside air damper control (0-100%).
20. AO – Exhaust air damper control (0-100%).
21. AO – Preheat coil valve control (0-100%; per coil section).

22. AO – Return air damper control (0-100%).
 23. AO – Return fan VFD speed control (0-100%; one (1) per VFD).
 24. AO – Supply fan VFD speed control (0-100%; one (1) per VFD).
 25. DI – Freezestat status (one (1) per each).
 26. DI – Return fan array high discharge pressure switch status.
 27. DI – Return fan array low intake pressure switch status.
 28. DI – Return fan status (via current sensing relay; one (1) per fan).
 29. DI – Return fan VFD common alarm (one (1) per VFD).
 30. DI – Supply fan array high discharge pressure switch status.
 31. DI – Supply fan array low intake pressure switch status.
 32. DI – Supply fan status (via current sensing relay; one (1) per fan).
 33. DI – Supply fan VFD common alarm (one (1) per VFD).
 34. DO – Return fan VFD command (enable/disable; one (1) per VFD).
 35. DO – Supply fan VFD command (enable/disable; one (1) per VFD).
- I. Provide the following points on the associated equipment graphic in addition to the hardwired points indicated above:
1. RTU command (enable/disable).
 2. RTU mode (warm-up, cool-down, economizer, normal, etc.)
 3. Humidification mode (on/off).
 4. Dirty filter alarm (indicated if filter differential pressure exceeds 1" (adj.)).
 5. Economizer available.
 6. Freezestat alarm.
 7. High and low preheat coil discharge air temperature alarms.
 8. High and low return air CFM alarms.
 9. High and low return air humidity alarms.
 10. High and low supply air static pressure alarms.
 11. High and low supply air temperature alarms.
 12. High supply air humidity alarm.
 13. Low condensate temperature alarm.
 14. Mixed air low limit setpoint.
 15. Outside air CFM setpoint.
 16. Outside air enthalpy.
 17. Outside air humidity (global point).
 18. Outside air minimum CFM setpoint.
 19. Outside air temperature (global point).

20. Preheat discharge low limit setpoint.
21. Return air CFM setpoint.
22. Return air enthalpy.
23. Return air humidity setpoint.
24. Return fan failure.
25. Return fan high discharge pressure alarm.
26. Return fan low intake pressure alarm.
27. Setback and setup temperature setpoints.
28. Supply air static pressure reset parameters.
29. Supply air static pressure setpoint.
30. Supply air temperature reset parameters.
31. Supply air temperature setpoint.
32. Supply fan failure.
33. Supply fan high discharge pressure alarm.
34. Supply fan low intake pressure alarm.

1.7 SNOW MELTING SYSTEM

- A. The snow melting system consists of one (1) glycol to steam heat exchanger, two (2) snow melting water pumps and manufacturer provided snow melting manifold system with controls.
- B. The BMS Contractor shall:
 1. Provide a DDC control panel for the snow melt system and all sensors and devices described below.
 2. Mount and wire all control components that are shipped with the snow melting manifold system that are not factory installed. Coordinate with the manufacturer for all field installation requirements.
 3. Furnish, mount and wire any additional components not provided by the snow melting manifold system manufacturer to achieve a completely operational system.
 4. Provide a two (2) 2-way control valve (1/3, 2/3 configuration) in the low pressure steam supply to the heat exchanger for controlling the snow melting hot water supply temperature.
- C. The snowmelt system is enabled to operate when the outside air temperature is below 38°F (adj.)
- D. The heat exchanger control algorithm shall be enabled by the snow melting system or manual command. Upon a command to enable the heat exchanger, the lead snow melting water pump shall be energized. The snow melting water pump self-sensing VFD shall operate at a preset speed determined during water balancing.
- E. When the snow melt system is enabled, the associated lead snow melt pump shall be commanded on and the heat exchanger 1/3, 2/3 valves shall modulate as

required to maintain the heat exchanger discharge temperature setpoint (adj.). The discharge temperature shall be limited by the slab return temperature, plus 20°F, (adj.), and the discharge setpoint shall be limited to a maximum temperature of 150°F (adj.) to prevent thermal cracking.

- F. When there is no moisture present at any of the associated snow sensors, then the system will enter idle mode. In this mode the discharge temperature is reset to maintain the lowest slab temperature of 30°F (adj.).
- G. When the snow melt system is enabled and there is moisture present at any of the associated snow sensors, then the system shall enter snow melt mode. In this mode, the discharge temperature is reset to maintain the lowest slab temperature at 38°F (adj.).
- H. Disabled Mode
 - 1. Heat Trace
 - a. The BMS contractor shall coordinate with the plumbing contractor for all heat trace BMS tie-in requirements.
 - b. The BMS contractor shall provide all necessary communication cabling as required to interface the heat trace system to the BMS via high level communications such as BACnet, Modbus, etc.
 - c. Heat Trace Mode
 - 1) Once the snow melt moisture sensors have dried for a period of 60 min (adj.), heat tracing on the roof (serving gutters and downspouts) shall be enabled via the BMS for 48 hours (adj.).
 - 2) MMC shall have the ability to override Heat Trace and Snow Melt via the BMS.
- I. When the snow melt system is disabled, the associated lead snow melt pump shall be commanded off and the heat exchanger 1/3, 2/3 valves shall close.
- J. At any time a pump command does not equal a pump status, except immediately after startup, a pump failure alarm shall be generated on the BMS and that pump shall be commanded off. The BMS shall wait 30 seconds to see the pump status change before indicating a pump failure alarm. An automatic lead/standby program shall start the standby pump in the event of a lead pump failure. The lead pump shall be the pump with the lower runtime hours. The standby pump shall be the pump with the higher runtime hours.
- K. Provide the following points hardwired to the BMS:
 - 1. All points available via a BACnet or Modbus communication interface to the VFDs, snowmelt packaged controls, and heat trace system.
 - 2. AI – Concrete Slab temperature (one (1) for each sensor).
 - 3. AI – Snow melting water pump VFD speed feedback (0-100%; one (1) for each pump).
 - 4. AI – Heat exchanger discharge temperature.

5. AO – Snow melting water pump VFD control (0-100%; one (1) for each pump).
 6. AO – Heat exchanger control valve control (1/3, 2/3; 0-100%).
 7. DI – Common alarm (if available from heat trace manufacturer provided controls).
 8. DI – Heat tracing on/off status (as sensed by a current sensing relay; install one (1) per heat tracing circuit and each current sensing relay shall be an individual input to the BMS).
 9. DI – Snow melting water pump status (via current sensing relay; one (1) for each pump).
 10. DI – Snow melting water pump VFD common alarm (one (1) for each pump).
 11. DO – Snow melt system enable.
 12. DO – Snow melting water pump VFD command (enable/disable; one (1) for each pump).
- L. Provide the following points on the associated equipment graphic in addition to the hardwired points indicated above:
1. Failure alarm (indicated if no moisture is present, outside air temperature is less 38°F (adj.), and heat tracing status is off).
 2. High and low concrete slab temperature alarms.
 3. High and low snow melting water supply temperature alarms.
 4. Outside air temperature (global point).
 5. Snow melting system command (on/off).
 6. Snow melting water pump failure.
 7. Snow melting water supply temperature reset parameters.
 8. Snow melting water supply temperature setpoint.
- 1.8 CONSTANT AIR VOLUME (CAV) BOXES WITH HOT WATER REHEAT (ISOLATION ROOMS)
- A. Coordinate factory mounting and wiring of secondary control panel, actuator and hot water valve with the box manufacturer. The BMS contractor shall be responsible for furnishing, installing and wiring of controls not furnished, installed or wired by others that are required for an operational system.
- B. Enabled Mode
1. The CAV box damper shall modulate as necessary to maintain the CFM setpoint. The CAV box hot water reheat valve shall modulate as necessary to maintain the space temperature setpoint. The CFM setpoint shall be as scheduled on the mechanical drawings.
- C. Disabled Mode
1. The CAV box damper shall close to minimum position.

- D. Provide one (1) DDC controller and one (1) temperature sensor for each CAV box.
 - E. Provide the following points hardwired to the BMS:
 - 1. AI – Discharge air temperature.
 - 2. AI – Space temperature.
 - 3. AI – Supply air CFM.
 - 4. AO – Damper control (0-100%).
 - 5. AO – Reheat valve control (0-100%).
 - F. Provide the following points on the associated equipment graphic in addition to the hardwired points indicated above:
 - 1. Box enable/disable.
 - 2. Box K factor.
 - 3. High and low space temperature alarms.
 - 4. Minimum/maximum/heating CFM settings.
 - 5. Heating/cooling temperature setpoints.
 - 6. Space/area served.
 - 7. Supply air CFM setpoint.
- 1.9 CONSTANT AIR VOLUME (CAV) EXHAUST BOXES (ISOLATION ROOMS)
- A. Coordinate factory mounting and wiring of secondary control panel, actuator and transformer with the box manufacturer. The BMS contractor shall be responsible for furnishing, installing and wiring of controls not furnished, installed or wired by others that are required for an operational system.
 - B. Enabled Mode
 - 1. The CAV exhaust box damper shall maintain the exhaust CFM setpoint. The CFM setpoint shall be as scheduled on the mechanical drawings.
 - C. Disabled Mode
 - 1. The CAV exhaust box damper shall close to minimum position.
 - D. Provide one (1) DDC controller for each box.
 - E. Provide the following points hardwired to the BMS:
 - 1. AO – Damper control (0-100%).
 - 2. AI – Exhaust air CFM.

- F. Provide the following points on the associated equipment graphic in addition to the hardwired points indicated above:
 - 1. Box enable/disable.
 - 2. Box K factor.
 - 3. Minimum/maximum/ CFM settings.
 - 4. Space/area served.
 - 5. Exhaust air CFM setpoint.

1.10 ROOM PRESSURE MONITORING (ISOLATION ROOM)

- A. The BMS contractor shall provide a TSI room pressure monitor for the isolation rooms. Refer to the mechanical drawings for locations.
- B. The TSI room pressure monitor shall come with a display and match the facility standard.
- C. Coordinate with the room pressure monitor manufacturer for all field installation requirements. The BMS contractor shall furnish all field wiring required for the room pressure monitor, including but not limited to wiring between the room pressure monitor and door switches.
- D. The BMS contractor shall provide door switches for each room being monitored. All door switches shall be wired as inputs to the room pressurization monitor. Double doors will require two (2) door switches.
- E. Provide all points available to the operator interface panel via BACnet or Modbus communication interface to the room pressure monitor. Coordinate with the manufacturer for available protocol.
- F. System operation
 - 1. The room pressurization monitor shall monitor the pressure in the associated pressurization room relative to the adjacent room.
 - 2. For negatively pressurized rooms relative to the adjacent space, if the room pressure is less than 0.03"wc (adj.; negative pressure) lower than the adjacent room for 30 seconds (adj.), the BMS shall annunciate a critical low room pressure alarm.
 - 3. If a door switch proves open for an extended period of time, 45 seconds (adj.), a "door open" alarm shall annunciate on the BMS that notifies building facility that a door is left open.
- G. Provide the following points on the BMS:
 - 1. All points available via a BACnet or Modbus communication interface to each room pressurization monitor.
 - 2. AI – Room differential pressure (per monitor).

3. DI – Door switch status (open/closed, per door).
 4. DI – Room pressure monitor common alarm.
- H. Provide the following points on the associated equipment graphic in addition to the hardwired points indicated above:
1. Door open alarm (per door).
 2. High and low room pressure alarm limits.
 3. High and low room pressure alarms.
 4. Room pressure critical alarm.
- 1.11 VARIABLE AIR VOLUME (VAV) BOXES WITH REHEAT INTERLOCKED WITH PERIMETER RADIANT PANEL VALVES
- A. Coordinate factory mounting and wiring of secondary control panel and actuator with the VAV box manufacturer. The BMS contractor shall be responsible for furnishing, installing and wiring of controls not furnished, installed or wired by others that are required for an operational system.
- B. Operating Mode 1 (Outside Air Temperature $\geq 60^{\circ}\text{F}$)
1. The radiant panel control valve shall be locked out in this mode of operation
 2. Upon a fall in space temperature below setpoint, the box damper shall modulate to its minimum CFM setpoint. If the box damper is at minimum position and the space temperature falls below setpoint, the box damper shall remain at minimum position and the VAV box hot water reheat valve shall modulate as necessary to maintain the space temperature setpoint. The VAV box reheat valve and VAV box damper shall stage in the reverse order upon a rise in space temperature.
 3. Upon a rise in space temperature, the box damper shall modulate from the minimum to the maximum CFM setting as necessary to maintain the CFM setpoint as reset by the space temperature. The minimum and maximum CFM settings shall be those scheduled on the mechanical drawings. The VAV box reheat valves shall remain closed.
- C. Operating Mode 2 (Outside Air Temperature $< 60^{\circ}\text{F}$)
1. Upon a fall in space temperature below setpoint, the box damper shall modulate to its minimum CFM setpoint. If the box damper is at minimum position and the space temperature falls below setpoint, the box damper shall remain at minimum position and the radiant panel valve shall open to maintain the space temperature setpoint. If the radiant panel valve is open 100%, and there is fall in space temperature below setpoint, the VAV box hot water reheat valve shall modulate as necessary to maintain the space temperature setpoint. The VAV box reheat valve, radiant panel valve, and VAV box damper shall stage in the reverse order upon a rise in space temperature.
 2. The radiant panel valves shall close when the space temperature is at setpoint plus a deadband (adj.). The radiant panel valves shall not be allowed to open

until the box is in minimum position and the box damper shall not be allowed to open beyond minimum position until the valve is closed.

3. Upon a rise in space temperature, the box damper shall modulate from the minimum to the maximum CFM setting as necessary to maintain the CFM setpoint as reset by the space temperature. The minimum and maximum CFM settings shall be those scheduled on the mechanical drawings. The radiation valves shall close, if open. The VAV box reheat valves shall remain closed.

D. Supply Air Temperature Reset

1. Coordinate all temperature reset sequences with MMC Controls standards.
2. When the zone state is cooling, the cooling loop output shall be mapped to the airflow setpoint from the cooling minimum (v_{min}) to the cooling maximum airflow setpoints ($v_{cool-max}$). The hot water valve shall close unless the discharge air temperature is below the minimum setpoint.
 - a. If supply air temperature from the air handler is greater than room temperature, cooling supply airflow setpoint shall be no higher than the minimum airflow setpoint (v_{min}).
3. When the zone state is deadband, the active airflow setpoint shall be the minimum airflow setpoint (v_{min}). The hot water valve is closed unless the discharge air temperature is below the minimum setpoint.
4. When the zone state is heating, the heating loop shall maintain space temperature at the heating setpoint as follows:
 - a. From 0-50%, the heating loop output shall reset the discharge temperature setpoint from the current AHU supply air temperature setpoint to a maximum of $\max \Delta T$ above space temperature setpoint. The airflow setpoint shall be the heating minimum.
 - 1) $\max \Delta T =$ The lesser of 90°F or (Space Temp + 15°F)
 - b. From 51%-100%, if the discharge air temperature is greater than room temperature plus (5°F), the heating loop output shall reset the airflow setpoint from the minimum airflow setpoint to the heating maximum airflow ($v_{heat-max}$) setpoint.
5. The hot water valve shall be modulated to maintain the discharge temperature at setpoint. (directly controlling heating off the zone temperature control loop is not acceptable)
6. In occupied mode, the hot water valve shall be modulated to maintain a discharge air temperature no lower than 50°F.

E. Unoccupied Mode

1. When the primary fan system serving the VAV box is not running, the VAV box damper shall close.
2. Unoccupied mode: the VAV shall be in unoccupied mode when the VAV is scheduled unoccupied and not triggered by optimal start/stop algorithms.
3. Unoccupied heating request:

- a. When the space temperature falls below the unoccupied space heating set point, the VAV shall call the parent ahu to run.
 - b. The VAV shall then modulate to maintain the vheat-max flow set point.
 - c. The VAV shall open its reheat 100%.
4. Unoccupied cooling request:
- a. When the space temperature rises above the unoccupied space cooling set point, the VAV shall call the parent ahu to run.
 - b. The VAV shall then modulate to maintain the vcool-max flow set point.
 - c. The VAV shall keep its reheat fully closed.
- F. The VAV box shall not open beyond the maximum CFM setting. Provide one (1) DDC controller and one (1) space temperature sensor with setpoint adjustment for each VAV box.
- G. Provide the following points hardwired to the BMS:
1. AI – Space temperature.
 2. AI – Supply air temperature.
 3. AI – Supply air CFM.
 4. AO – Damper control (0-100%).
 5. AO – Reheat valve control (0-100%).
 6. AO – Radiation valve control (0-100%).
- H. Provide the following points on the associated equipment graphic in addition to the hardwired points indicated above:
1. Box enable/disable.
 2. Box k factor.
 3. Force damper full open/close.
 4. Force zone airflow setpoint to vcool-max.
 5. Force zone airflow setpoint to vmin.
 6. Force zone airflow setpoint to zero.
 7. Heating/cooling temperature setpoints.
 8. High and low space temperature alarms.
 9. Minimum/maximum/heating CFM settings.
 10. Operating Mode (Mode 1 and Mode 2).
 11. Space/area served.
 12. Supply air CFM setpoint.

1.12 FAN-POWERED BOX (FPB) WITH HOT WATER REHEAT (series)

- A. Coordinate factory mounting and wiring of secondary control panel, actuator, transformer, relays and controller with the FPB box manufacturer. The BMS contractor shall be responsible for furnishing, installing and wiring of controls not furnished, installed or wired by others that are required for an operational system.
- B. Enabled Mode
 - 1. The FPB damper shall modulate as necessary to maintain the CFM setpoint. The FPB hot water reheat valve shall modulate as necessary to maintain the space temperature setpoint. The CFM setpoint shall be as scheduled on the mechanical drawings.
 - 2. The FPB fan shall run continuously.
 - 3. The FPB discharge air reset sequence shall be similar to the VAV box discharge air reset sequence referenced above. Coordinate all temperature reset sequences with MMC Controls standards.
- C. Disabled Mode
 - 1. The FPB damper shall close to its minimum position.
 - 2. The FPB fan shall disable.
- D. The FPB box damper shall not open beyond the maximum CFM setting. Provide one (1) DDC controller and one (1) temperature sensor for each FPB box.
- E. Provide the following points hardwired to the BMS:
 - 1. AI – Discharge air temperature.
 - 2. AI – Space temperature.
 - 3. AI – Supply air CFM.
 - 4. AO – Damper control (0-100%).
 - 5. AO – Hot water reheat control (0-100%).
 - 6. DO – Fan command.
- F. Provide the following points on the associated equipment graphic in addition to the hardwired points indicated above:
 - 1. Box enable/disable.
 - 2. Box K factor.
 - 3. High and low space temperature alarms.
 - 4. Minimum/maximum/heating CFM settings.
 - 5. Occupied/unoccupied command.
 - 6. Occupied/unoccupied, heating/cooling temperature setpoints.

7. Space/area served.
8. Supply air CFM setpoint.

1.13 ISOLATION ROOM EXHAUST FANS

- A. The fan shall be started/stopped based upon a time of day schedule or manual command and run continuously.
- B. Upon a command to start the fan, the fan discharge damper shall open. When the damper is open, as sensed by a damper end switch, the fan shall energize.
- C. The fan's VFD shall start unloaded and slowly ramp up to maintain the duct static pressure setpoint (adj.) as sensed by a static pressure sensor 2/3 downstream of the fan.
- D. Upon a command to de-energize the fan, the discharge damper shall have an adjustable time delay to keep the damper open up to 30 seconds after the fan VFD is de-energized.
- E. Provide the following points hardwired to the BMS:
 1. All points available via integration (BACNet, Modbus) to each VFD.
 2. AI – Duct static pressure level.
 3. AI – Exhaust fan VFD speed feedback (0-100%).
 4. AO – Exhaust fan VFD speed control (0-100%).
 5. DI – Exhaust fan status (via current sensing relay).
 6. DI – Exhaust fan VFD common alarm.
 7. DO – Exhaust fan VFD command (on/off).
- F. Provide the following points on the associated equipment graphic in addition to the hardwired points indicated above:
 1. Duct static pressure setpoint.
 2. Fan failure alarm.
 3. High / low duct static pressure alarms.
 4. Occupied/unoccupied command.
 5. Space/area served.

1.14 TOILET EXHAUST FANS

- A. The fan shall be started/stopped based upon a time of day schedule or manual command and run continuously.
- B. Upon a command to start the fan, the fan discharge damper shall open. When the damper is open, as sensed by a damper end switch, the fan shall energize. Upon a command to de-energize the fan, the discharge damper shall have an adjustable time delay to keep the damper open up to 30 seconds after the fan is de-energized.
- C. Provide the following points hardwired to the BMS:
 1. DI – Individual fan status (via current sensing relay).

2. DO – Individual fan command (on/off).

D. Provide the following points on the associated equipment graphic in addition to the hardwired points indicated above:

1. Fan failure alarm.
2. Occupied/unoccupied command.
3. Space/area served.

1.15 CABINET UNIT HEATERS

A. On a fall in space temperature below setpoint, the unit fan shall be energized and control valve shall open. On a rise in space temperature above setpoint plus a differential, the fan shall be de-energized and the control valve shall close.

B. The BMS shall lock out the fan if hot water is not available.

C. Provide the following points hardwired to the BMS:

1. AI – Space temperature.
2. DI – Fan status (via current sensing relay).
3. DO – Fan command.
4. AO – Valve control (0-100%).

D. Provide the following points on the associated equipment graphic in addition to the hardwired points indicated above:

1. Fan failure.
2. High and low space temperature alarms.
3. Space temperature setpoint.
4. Space/area served.

1.16 STAIRWELL PRESSURIZATION FANS

A. Upon a detection of smoke on the floor or as determined necessary by the fire alarm system, the stair pressurization shall be enabled.

B. Upon a command to enable stair pressurization, the associated fire/smoke damper at the staircase shall open, the motorized relief damper shall open and the stair pressurization fan shall be commanded on.

C. Upon a command to enable the stair pressurization fan, the fan isolation damper shall open. When the damper is open, as sensed by a damper end switch, the fan VFD shall energize.

D. The stair pressurization fan variable frequency drive shall start unloaded and slowly ramp up to a preset speed determined during balancing.

E. The mechanical gravity backdraft damper shall operate as required to maintain positive pressure in each stairwell.

F. Upon a command to de-energize the stair pressurization fan, the isolation damper shall have an adjustable time delay to keep the damper open up to 30 seconds after the fan is de-energized.

- G. Provide the following points hardwired to the BMS:
 - 1. All points available via integration (BACNet, Modbus) to each VFD.
 - 2. AI – Pressurization fan VFD speed feedback (one (1) for each fan).
 - 3. AO – Pressurization fan VFD control (0-100%, one (1) for each fan).
 - 4. DI – Pressurization fan status (via current sensing relay, one (1) for each fan).
 - 5. DI – Pressurization fan VFD common alarm (one (1) for each fan).
 - H. Provide the following points on the associated equipment graphic in addition to the hardwired points indicated above:
 - 1. Space/area served.
 - 2. Stair pressurization fan failure.
- 1.17 EXISTING ELEVATOR CONTROLLERS ROOM AND ELEVATOR HOISTWAY AC UNITS
- A. There is one (1) existing elevator controllers room AC unit and two (2) exiting elevator hoistway AC units being relocated as a part of this project. The unit's associated controls devices shall be reused. The existing AC unit shall reuse its associated existing sequence of operations.
 - B. The BMS contractor shall:
 - 1. Coordinate with the mechanical contractor as needed for the relocation of the ac unit and associated controls.
 - 2. Extend wiring from the existing controls devices to the associated new location, if deemed necessary.
 - 3. Test, commission, recalibrate the existing ac unit controls and associated controls devices.
 - 4. Report to the owner of any existing ac unit controls or associated controls devices that are determined to be insufficient in ensuring that the existing ac unit operate as per their existing sequence of operation.
 - 5. Provide the owner with a spreadsheet listing all the existing ac unit controls or associated controls devices requiring replacement.
- 1.18 EXISTING EMERGENCY DROP-OFF EXHAUST FAN
- A. There is one (1) existing emergency drop-off exhaust fan that shall be relocated as a part of this project. The fans associated controls devices shall be reused. The existing exhaust fan shall reuse its associated existing sequence of operations.
 - B. The BMS contractor shall:
 - 1. Coordinate with the mechanical contractor as needed for the relocation of the exhaust fan and associated controls.
 - 2. Extend wiring from the existing controls devices to the associated new location, if deemed necessary.
 - 3. Test, commission, recalibrate the existing exhaust fan controls and associated controls devices.

4. Report to the owner of any existing exhaust fan controls or associated controls devices that are determined to be insufficient in ensuring that the existing exhaust fan shall operate as per their existing sequence of operation.
- C. Provide the owner with a spreadsheet listing all the existing exhaust fan devices requiring replacement.

1.19 HELIPAD EXHAUST CONTROL

- A. There are two (2) helipads associated with the East Tower. The sequence of operations below shows how the helicopter exhaust can be controlled/prevented from being taken into the outside air intake of five (5) air handling units at the adjacent Richards Building and four (4) air handling units on the roof of East Tower. The air handling units are tagged as follows:
 1. Richards Building AHU's
 - a. AHU-12
 - b. AHU-13
 - c. AHU-50
 - d. AHU-89
 - e. AHU-113
 2. East Tower AHU's
 - a. AHU-133
 - b. AHU-134
 - c. AHU-135
 - d. AHU-136
- B. The BMS contractor shall:
 1. Coordinate with the helipad consultant for all necessary system requirements.
 2. Furnish, mount, and wire any additional components not provided by the helipad manufacturer to achieve a completely operational system.
 3. Provide a separate BMS graphics slide/page for this helipad system. The graphics shall include reference to each AHU outside air damper and an option for each AHU to be activated/de-activated within the associated sequence referenced below.
- C. Upon activation of the pilot operated remote controller, the exhaust control sequence shall be enabled. All associated air handling unit outside air dampers shall modulate to minimum CFM position via a BMS software program.
- D. The MMC facility shall have the ability enable/disable any of the associated AHU's (mentioned above) from the outside air damper override program. For example, upon activation of the HOA switch or pilot remote controller, the BMS operator shall have the ability to remove any associated AHU (AHU-12, AHU-13, etc.) from the automatic program.

- E. The helipad exhaust control sequence shall be manually disabled via the BMS or automatically disabled after a 60 min (adj.) time delay.
- F. Provide the following points on the associated equipment graphic in addition to the hardwired points indicated above:
 - 1. Helipad Exhaust Control Mode.
 - 2. AHU Exhaust Control Mode Enable/Disable.

1.20 AIR COOLED SPLIT AC UNIT (AC-1)

A. General

- 1. The evaporator and condenser units shall be provided with manufacturer provided controls. Coordinate with the AC unit manufacturer for all field installation requirements.
- 2. The unit shall operate as per the manufacturer provided sequence of operation.

B. The BMS contractor shall:

- 1. Mount and wire all control components that are shipped with the AC unit that are not factory installed. This shall include, but not be limited to, wiring between condenser unit, evaporator unit and manufacturer provided wall-mounted thermostat.
- 2. Furnish, mount and wire any additional components not provided by the AC unit manufacturer to achieve a completely operational system.

C. Enable/Disable Mode

- 1. The air-cooled condensing outdoor unit shall be hardwired interlocked with the indoor AC unit. When the indoor AC unit is energized, the air-cooled condensing outdoor unit shall be enabled.
- 2. The indoor air conditioning unit shall be controlled by its own manufacturer provided thermostat. The supply fan shall run continuously when the unit is enabled.
- 3. The manufacturer provided controls shall cycle the compressors as necessary to maintain the space temperature setpoint.
- 4. Upon a command to stop, the compressor shall be cycled off; the supply fan shall be de-energized.

D. Provide the following points hardwired to the BMS:

- 1. All points available to each AC unit via integration (BACnet).
- 2. AI – Space temperature (hardwired point via additional space temp sensor)
- 3. DI – AC unit status.

- E. Provide the following points on the associated equipment graphic in addition to the hardwired points indicated above:
 - 1. High and low space temperature alarms.
 - 2. AC unit failure.

1.21 ELECTRIC UNIT HEATERS (AHU Vestibules)

- A. The electric unit heater shall be provided with manufacturer provided controls. The BMS contractor shall provide field wiring for all control devices shipped loose. The BMS contractor shall coordinate with the manufacturer for all field installation requirements.
- B. The BMS contractor shall furnish, install and wire any devices not provided by the manufacturer to ensure a completely operations system. This shall include but not be limited to a space thermostat.
- C. On a fall in space temperature below setpoint, the thermostat shall energize the unit fan and electric heating coil to maintain the space temperature setpoint (adj.). On a rise in space temperature, the electric heating coil and the fan shall be de-energized. The heaters shall operate independent of the BMS.
- D. Provide one (1) DDC space temperature sensor per each vestibule that alarms at the BMS if a temperature reading below 40°F (adj.) occurs.
- E. Provide the following points hardwired to the BMS:
 - 1. AI – Space temperature.
- F. Provide the following points on the associated equipment graphic in addition to the hardwired points indicated above:
 - 1. Low space temperature alarm.

1.22 ENERGY (BTU) METERING

- A. The BMS contractor shall furnish, install, wire, and commission an insertion magnetic BTU meter and a steam inline vortex meter for the following systems:
 - 1. Chilled water main serving the two new AHU's (AHU-149 and 150)
 - 2. Variable hot water system for perimeter heat
 - 3. Reheat hot water loop
 - 4. Glycol system serving snow melt for Helipad
 - 5. Humidification steam
 - 6. Steam main serving AHU-149 and 150
 - 7. Domestic Cold Water (Plumbing)
 - 8. Domestic Hot Water (Plumbing)

9. Domestic Hot Water Recirc. (Plumbing)
 - B. Refer to the mechanical plans for locations. The BMS contractor shall coordinate the location of meters with the meter manufacturer.
 - C. The BMS contractor shall provide all necessary communication cabling as required to interface the "Factory Talk Servers" to the BMS via high level communications such as BACnet, Modbus, etc. The "Factory Talk Servers" shall be provided by others. Coordinate with MMC for all metering points and tie-in requirements.
 - D. The following points shall be available via integration to each "Factory Talk Server" at a minimum:
 1. Chilled water flow rate (GPM; one (1) per each meter).
 2. Chilled water energy (BTU; one (1) per each meter).
 3. Hot water flow rate (GPM; one (1) per each meter).
 4. Hot water energy (BTU; one (1) per each meter).
 5. Steam flow rate (one (1) per each meter).
 6. Steam energy (one (1) per each meter).
 7. Domestic hot/cold water flow rate (GPM; one (1) per each meter).
 8. Domestic hot/cold water energy (one (1) per each meter).
- 1.23 SMOKE PURGE
- A. Smoke Condition
 1. Upon detection of smoke from either the respective AHU supply or return mounted smoke detector the system supply and return fans shall disengage via the FAS. The following shall also occur:
 - a. The outside and exhaust air dampers shall close.
 - b. The cooling coil control valve shall close.
 - c. A signal shall be received by the BMS indicating smoke shutdown (from the F.A.C.P.).
 - d. The system smoke and/fire smoke dampers shall close.
 2. Fire Smoke Dampers
 - a. The Fire/Smoke Dampers (other than those indicated to be hardwire interlocked with a fan) shall remain open until de-energized by the Fire Alarm System.
 - b. The BMS shall monitor the status of the floor fire/smoke dampers by wiring the normally open end switch back to the BMS.

3. Operation and/or activation of any alarm device shall automatically operate control relay contacts to shutdown all air handling systems. The fan shutdown relays shall not be permitted to be reset from the simple operation of the system reset switch. A separate fan systems restart switch shall be provided at the fire alarm control panel to permit the resetting of the fan shutdown relays after the fire detection and alarm system has been reset to normal. Work described above is by electrical contractor. Refer to Electrical drawings.
4. The BMS shall receive notification from the fire alarm system that the building is in alarm. Coordinate inputs/outputs and termination with the fire alarm contractor.

B. Smoke Purge Mode

1. Smoke purge shall be activated on a floor-by-floor basis from the Smoke Purge Control Panel.
2. The Smoke Purge Control Panel, provided by the BMS contractor, shall be supplied with Fire Department approved key switches. Upon activation, the Smoke Purge Control Panel shall send a signal to the BMS to initiate the smoke purge mode.
3. The purge control panel shall start the associated floor AHU return fan and open fire smoke dampers which are located in the return air system associated with the floor to be purged. A signal from the smoke purge control panel shall signal the return fan to go into the purge mode. The exhaust air dampers and fire/smoke dampers in the return air system shall open prior to sending the signal for the return fan to go into the purge mode. The end switch at each damper shall provide proof each damper is fully open before the signal to start the return fan is sent.
4. Each floor served by an associated AHU return fan shall be capable of being purged independent of the other floors. Each floor shall have a switch on the smoke purge panel that initiates smoke purge for that floor only. This includes which floors shall be purged by which AHU return fan.
5. Coordinate all F/SD, FAS, and Smoke Purge requirements with the FAS contractor.

1.24 MISCELLANEOUS POINTS

- A. Provide the following points hardwired to the BMS:
1. DI - Vacuum Pump Trouble Alarm.

1.25 STEAM TO HOT WATER HEAT EXCHANGER (HX-3, P-194, P-195)

- A. This system shall serve hot water to the reheat loop in the building.
- B. Provide two (2) control valves to control the steam input to the heat exchanger. The two (2) control valves shall be sized for 1/3 and 2/3 capacity. Provide an individual control output to each control valve.

- C. The heat exchanger control algorithm shall be enabled via time schedule or manual command. The system shall be programmed to run 24 hours a day, 7 days a week.
- D. Upon a command to enable the heat exchanger, the lead hot water pump shall be energized. The hot water pump self-sensing VFD shall operate at a preset speed determined during water balancing.
- E. When the lead hot water pump is on, the heat exchanger's 1/3 and 2/3 steam valves shall be allowed to operate. The staged 1/3 and 2/3 heat exchanger steam control valves shall modulate as necessary to maintain the hot water supply temperature setpoint of 180°F (adj.).
- F. At any time a pump command does not equal a pump status, except immediately after startup, a pump failure alarm shall be generated on the BMS and that pump shall be commanded off. The BMS shall wait 30 seconds to see the pump status change before indicating a pump failure alarm. An automatic lead/lag program shall start the lag pump in the event of a lead pump failure. The lead and lag pumps shall rotate on a weekly basis based on runtime.
- G. When the heat exchanger is disabled, the steam control valves shall close. The hot water pumps shall be de-energized.
- H. Provide the following points hardwired to the BMS:
 - 1. AI – Hot water supply temperature.
 - 2. AI – Hot water return temperature.
 - 3. AI – Hot water pump VFD speed feedback ((0-100%); one (1) for each pump).
 - 4. DI – Hot water pump VFD common alarm (one (1) for each pump).
 - 5. DI – Hot water pump status (via current sensing relay; one (1) for each pump).
 - 6. DO – Hot water pump VFD command (enable/disable; one (1) for each pump).
 - 7. AO – Hot water pump VFD control (0-100%; one (1) for each pump).
 - 8. AO – 1/3 steam valve control (0-100%).
 - 9. AO – 2/3 steam valve control (0-100%).
- I. Provide the following points on the associated equipment graphic in addition to the hardwired points indicated above:
 - 1. Heat exchanger command (on/off).
 - 2. Hot water supply temperature setpoint.
 - 3. Heat exchanger enable/disable outside air interlock setpoint.
 - 4. High and low hot water supply temperature alarms.

5. Hot water pump failure.

1.26 AIR COOLED PACKAGED ROOFTOP UNIT (AHU-142)

A. General

1. This packaged air cooled DX cooling only rooftop unit shall be a constant volume unit that serves the elevator control room.
2. The unit shall be provided with manufacturer provided controls. Coordinate with the rooftop unit manufacturer for all field installation requirements.
3. The unit shall operate as per the manufacturer provided sequence of operation.

B. The BMS contractor shall:

1. Mount and wire all control components that are shipped with the rooftop unit that are not factory installed.
2. Furnish, mount and wire any additional components not provided by the rooftop unit manufacturer to achieve a completely operational system.

C. Enable/Disable Mode

1. The rooftop unit shall be controlled by its own manufacturer provided thermostat/controls. The supply fan shall run continuously when the unit is enabled.
2. The manufacturer provided controls shall cycle the compressors as necessary to maintain the space temperature setpoint.
3. The unit shall operate in airside economizer with power exhaust as per the manufacturer provided sequence of operations.
4. Upon a command to stop, the compressor shall be cycled off; the supply fan shall be de-energized.

D. Provide the following points hardwired to the BMS:

1. All points available to each AC unit via integration (BACnet).
2. AI – Space temperature (hardwired point via additional space temp sensor)
3. DI – AC unit status.

E. Provide the following points on the associated equipment graphic in addition to the hardwired points indicated above:

1. High and low space temperature alarms.
2. AC unit failure.

1.27 ELEVATOR HOISTWAY VENTS

- A. Upon a signal from a duct smoke, or the FAS, the hoistway vent associated smoke dampers shall open via hardwire interlock.

1.28 AUTOMATIC RESTART SEQUENCE

- A. The BMS contractor shall submit an automatic restart sequence of operation that prioritizes the loads to be restarted, in order of importance, when a changeover in power occurs, either from normal power to emergency power or from emergency power to normal power and when there is more than one (1) piece of mechanical equipment to start at the same time (e.g., at the beginning of a normally scheduled occupied cycle). The automatic restart sequence of operation shall also show the time delays between the startup of each piece of mechanical equipment.
- B. Simultaneous starting of motors shall be prevented by a sequential start program in the DDC system. This program shall also provide sequential restart after power failure of motors that were running prior to power failure.
- C. Automatic restart of fans after a safety shutdown trip shall be software prohibited through the de-energization of the remote start/stop contact. Fan restart shall be manually initiated by the operator either locally or remotely through a computer workstation after resolving the cause for shutdown.
- D. The BMS contractor shall provide a prioritization schedule to stage on equipment. Equipment shall be prioritized from highest to lowest as follows:
1. Life Safety Systems
 2. Patient and Critical Care Systems
 3. All Other Systems
- E. Operator Workstation: Display the following data:
1. Individual minimum interval time for each piece of mechanical equipment.
 2. Individual minimum off time for each piece of mechanical equipment.
 3. Individual motor horsepower.
 4. Individual restart delay for each piece of mechanical equipment.

END OF SECTION

This page is intentionally left blank.

SECTION 23 21 13

HYDRONIC PIPING

PART 1 - GENERAL

1.1 RELATED DOCUMENTS

- A. Drawings and general provisions of the Contract, including General and Supplementary Conditions and Division 01 Specification Sections, apply to this Section.
- B. Section 01 81 13 "Sustainable Design Requirements – LEED v4 for Building Design & Construction – New Construction" for sustainable design requirements and detailed sustainable design submittal requirements.
- C. Section 01 74 19 "Construction and Demolition Waste Management and Disposal" for disposal of construction, demolition and packaging waste disposal requirements.

1.2 SUMMARY

- A. This Section includes pipe and fitting materials, joining methods, special-duty valves, and specialties for the following:
 - 1. Hot-water heating piping.
 - 2. Chilled-water piping.
 - 3. Makeup-water piping.
 - 4. Condensate-drain piping.
 - 5. Blowdown-drain piping.
 - 6. Air-vent piping.
 - 7. Air control devices
 - 8. Strainers
 - 9. Vacuum Breakers
 - 10. Drain coolers
- B. Related Sections include the following:
 - 1. Division 23 Section "Hydronic Pumps" for pumps, motors, and accessories for hydronic piping.
- C. Sustainable Building Requirements:
 - 1. The Owner requires the Contractor to implement practices and procedures to meet the project's environmental performance goals, which include achieving LEED version 4 **Certified** level Certification. Specific project goals that may impact this area of work include: use of recycled-content materials; use of locally-manufactured materials; use of low-emitting materials; construction waste recycling; and the implementation of a construction indoor air quality management plan. The Contractor shall ensure that the requirements related to these goals, as defined in the Articles below, are implemented to the fullest extent. Substitutions, or other changes to the work proposed by the Contractor or their Subcontractors, shall not be allowed if such changes compromise the aforementioned environmental goals and LEED certification.

1.3 DEFINITIONS

- A. PTFE: Polytetrafluoroethylene.

1.4 PERFORMANCE REQUIREMENTS

- A. Hydronic piping components and installation shall be capable of withstanding the minimum working pressure and temperature of the systems listed in the PIPING APPLICATIONS section in Part 3 and as follows:
 1. Hot-Water Heating Piping: 150 psig at 200 deg F .
 2. Chilled-Water Piping: 150 psig at 200 deg F.
 3. Condensate-Drain Piping: 150 deg F .
 4. Blowdown-Drain Piping: 200 deg F.
 5. Air-Vent Piping: 200 deg F.
 6. Make-up water piping: 80 psig at 150 deg. F.

1.5 SUBMITTALS

- A. Product Data: For each type of the following:
 1. Submit a schedule indicating the following:
 - a. System Service, Operating temperature, Operating pressure, Pipe material, Fittings, Methods of joining, Gaskets, Specialties, Test pressure, Flange gaskets, , Fittings., Unions, , Suction diffusers, Ring spacers and test blanks.
 2. Valves. Include flow and pressure drop curves based on manufacturer's testing for calibrated-orifice balancing valves and automatic flow-control valves.
 3. Strainers
 4. Air control devices.
 5. Hydronic specialties.
- B. Shop Drawings: Detail, at 3/8 inch scale piping layout with fittings, valves and equipment, use single line for pipe sizes 3 inches and smaller, and double line for pipe sizes 4 inches and greater. fabrication of pipe anchors, hangers, supports for multiple pipes, alignment guides, expansion joints and loops, and attachments of the same to the building structure. Detail location of anchors, alignment guides, and expansion joints and loops
 1. Minimum 3/8 inch scale double line layout and sections where required or coordination drawings
- C. Grooved joint couplings and fittings shall be shown on drawings and product submittals, and be specifically identified with the applicable Victaulic style or series number
- D. Welding certificates
- E. Qualification Data: For Installer
- F. Field quality-control test reports, Written reports of tests specified in Part 3 of this Section. Include the following:
 1. Test procedures used.
 2. Test results that comply with requirements
 3. Failed test results and corrective action taken to achieve requirements
- G. Operation and Maintenance Data: For air control devices, hydronic specialties, and special-duty valves to include in emergency, operation, and maintenance manuals

1.6 QUALITY ASSURANCE

- A. Installer Qualifications:
- B. Steel Support Welding: Qualify processes and operators according to AWS D1.1/D1.1M, "Structural Welding Code - Steel."
- C. Certify that each welder has passed AWS qualification tests for welding processes involved and that certification is current
- D. Welding: Qualify processes and operators according to ASME Boiler and Pressure Vessel Code: Section IX.
 - 1. Comply with provisions in ASME B31 Series, "Code for Pressure Piping."
 - 2. Certify that each welder has passed AWS qualification tests for welding processes involved and that certification is current.
- E. ASME Compliance: Comply with ASME B31.9, "Building Services Piping," for materials, products, and installation. Safety valves and pressure vessels shall bear the appropriate ASME label. Fabricate and stamp air separators and expansion tanks to comply with ASME Boiler and Pressure Vessel Code: Section VIII, Division 01.
- F. To assure uniformity and compatibility of piping components in grooved piping systems, all grooved products utilized shall be supplied by Victaulic. Grooving tools shall be supplied by the same manufacturer as the grooved components.
- G. Steel Pipe Welding:
 - 1. Qualify processes and operators according to ASME Boiler and Pressure Vessel Code: Section IX, "Welding and Brazing Qualifications."
 - 2. Welders shall be qualified for all required pipe sizes, material, wall thickness, and position in accordance with the American Society of Mechanical Engineering (ASME) Section IX, boiler and pressure Vessel Code
 - 3. Copies of the certified welder qualification reports shall be maintained by the responsible welding agency and the company performing the welding, and shall be submitted to the owner and/or Inspector upon request.
 - 4. All defective welds shall be chipped out and repaired at no cost to the Owner, based on procedure to be specified at the time.
 - 5. The contractor shall bear the cost of reinspection of the repaired welds and the inspection of two (2) additional welds, as selected by the owner, for each failed weld.
 - 6. Field Procedures:
 - a. Clean pipe free from rust, scale and oxide.
 - b. Bevel pipe on each end per acceptable procedures.
 - c. Contractor is responsible for preparation of pipe in accordance with ASME B 31.1, Chapter V and for visual inspection during the welding operation and for all required welding examinations with certified welding inspector(s), in accordance with ANSI/AWS B.1.10-86 or latest issue section 3.1, 3.1.1, 3.1.2, and 3.1.3.
- H. Copper Tube Brazing
 - 1. Qualify process and operators in accordance with ASME Boiler and Pressure Vessel Code, Section IX, "Welding and Brazing Qualifications"
 - 2. Brazers shall be qualified for all required tube sizes, material, wall thickness, and position in accordance with the American Society of Mechanical Engineering (ASME), Section IX, boiler and Pressure Vessel Code.

3. Brazing qualification testing shall be performed an agency/laboratory certified by ASME.
4. Copies of the certified brazer qualification reports shall be maintained by the responsible brazing agency and the company performing the brazing, and shall be submitted to the owner and/or Inspector.
5. All defective brazements shall be chipped out and repaired at no cost to the Owner, based on procedure to be specified at the time.
6. The contractor shall bear the cost of re-inspection of the repaired brazements and the inspection of two (2) additional brazements, as selected by the owner, for each failed brazement.
7. Field Procedures:
 - a. Clean tubing free from surface oxidation on the O.D.
 - b. Ream all tubes and remove burrs created by the cutting operation, on each end per acceptable procedures.
 - c. Contractor is responsible for preparation of tubes and for visual inspection during the brazing operation in accordance with all applicable ASME, ANSI and AWS standards.

1.7 COORDINATION

- A. Coordinate layout and installation of hydronic piping and suspension system components with other construction, including light fixtures, HVAC equipment, fire-suppression-system components, structure and partition assemblies.
- B. Coordinate pipe sleeve installations for foundation wall penetrations.
- C. Coordinate piping installation with roof curbs, equipment supports, and roof penetrations. Roof specialties are specified in Division 7 Sections.
- D. Coordinate pipe fitting pressure classes with products specified in related Sections.
- E. Coordinate size and location of concrete bases. Cast anchor-bolt inserts into base. Concrete, reinforcement, and formwork requirements are specified in Division 3 Sections.
- F. Coordinate installation of pipe sleeves for penetrations through exterior walls and floor assemblies. Coordinate with requirements for firestopping for fire and smoke wall and floor assemblies.

PART 2 - PRODUCTS

2.1 COPPER TUBE AND FITTINGS

- A. Drawn-Temper Copper Tubing: ASTM B 88, Type L (ASTM B 88M, Type B)
- B. Annealed-Temper Copper Tubing: ASTM B 88, Type L (ASTM B 88M, Type A)
- C. Wrought-Copper Fittings: ASME B16.22
 1. Manufacturers: Subject to compliance with requirements, provide products by one of the following:
 - a. Victaulic
 2. Grooved-End Copper Fittings: ASTM B 75 (ASTM B 75M), copper tube or ASTM B 152 wrought copper fittings with copper tubing sized grooved ends designed to accept Victaulic coupling. Flaring of tube and fitting ends to IPS dimensions is not permitted.

3. Grooved-End-Tube Couplings: Rigid pattern, unless otherwise indicated; gasketed fitting. Ductile-iron housing with keys matching pipe and fitting grooves, EPDM gasket rated for minimum 230 deg F (110 deg C) for use with housing, and steel bolts and nuts.
 - a. NPS 2 through NPS 8: Standard rigid couplings with pressure-responsive, synthetic rubber gasket Grade "EHP" EPDM rated for temperatures up to 250 deg F, secured together with plated steel bolts and nuts. Victaulic Style 607.
 4. Grooved-End-Tube Flange Adapters: Cast ductile iron coated with copper-colored enamel, flat faced, for engaging into roll grooved copper tube and fittings and bolting directly to ANSI Class 125 and 150 bolt hole patterns. Victaulic Style 641.
 5. Grooved joints not allowed on hot water system
- D. Wrought-Copper Unions: ASME B16.22
- ## 2.2 STEEL PIPE AND FITTINGS
- A. Steel Pipe: ASTM A 53/A 53M, black steel with plain ends; type, grade, and wall thickness as indicated in Part 3 "Piping Applications" Article.
 - B. Cast-Iron Threaded Fittings: ASME B16.4; Classes 125 and 250 as indicated in Part 3 "Piping Applications" Article.
 - C. Malleable-Iron Threaded Fittings: ASME B16.3, Classes 150 and 300 as indicated in Part 3 "Piping Applications" Article.
 - D. Malleable-Iron Unions: ASME B16.39; Classes 150, 250, and 300 as indicated in Part 3 "Piping Applications" Article.
 - E. Cast-Iron Pipe Flanges and Flanged Fittings: ASME B16.1, Classes 25, 125, and 250; raised ground face, and bolt holes spot faced as indicated in Part 3 "Piping Applications" Article.
 - F. Wrought-Steel Fittings: ASTM A 234/A 234M, wall thickness to match adjoining pipe.
 - G. Wrought Cast- and Forged-Steel Flanges and Flanged Fittings: ASME B16.5, including bolts, nuts, and gaskets of the following material group, end connections, and facings:
 1. Material Group: 1.1.
 2. End Connections: Butt welding.
 3. Facings: Raised face.
 - H. Grooved Mechanical-Joint Fittings and Couplings:
 1. Manufacturers: Subject to compliance with requirements, provide products by one of the following:
 - a. Victaulic Company of America.
 2. Joint Fittings: ASTM A 536, Grade 65-45-12 ductile iron; or ASTM A 53/A 53M, Type F, E, or S, Grade B fabricated steel fittings with grooves or shoulders constructed to accept Victaulic standard and AGS "W" series grooved-end couplings; with nuts, bolts, locking pin, locking toggle, or lugs to secure grooved pipe and fittings.
 3. Standard Couplings, 2" through 12": Ductile- iron housing and synthetic rubber gasket of central cavity pressure-responsive design; with nuts, bolts, locking pin, locking toggle, or lugs to secure grooved pipe and fittings.

- a. Rigid Type: Housings shall be cast with offsetting, angle-pattern bolt pads to provide system rigidity and support and hanging in accordance with ASME B31.1 and B31.9.
 1. 2" through 8" Sizes: Victaulic Style 107 installation ready rigid coupling, Grade "EHP" EPDM gasket with red color code for water services from -30 deg F (-34 deg C) to +250 deg F (+121 deg C).
 2. 10" through 12" Sizes: Victaulic Style 07 (Zero-Flex®) standard rigid coupling with Grade "E" EPDM gasket with green color code for water services from -30 deg F (-34 deg C) to +230 deg F (+110 deg C).
 3. Housings shall incorporate an angled-pattern bolt pad design to confirm joint rigidity upon visual confirmation of metal-to-metal bolt pad contact with no torque requirement. Designs that permit spaces at bolt pads or require a torque per written manufacturers installation instructions not permitted.
 - b. Flexible Type: Use in locations where vibration attenuation and stress relief are required. Flexible couplings may be used in lieu of flexible connectors for vibration isolation at equipment connections. Three couplings, for each connector shall be placed in close proximity to the vibration source in accordance with published guidelines. Victaulic Style 177,77 or W77.
4. AGS Couplings, 14" through 24": Two ductile iron housings cast with a wide key profile, lead-in chamfer and flat bolt pads for metal-to-metal contact, pressure-responsive, synthetic rubber gasket of a FlushSeal® design, and plated steel bolts and nuts.
 - a. Rigid Type: Provides a rigid joint that corresponds with support spacings as defined by ASME B31.1 and B31.9. Victaulic Style W07.
 - b. Flexible Type: Allows for linear and angular movement, vibration attenuation and stress relief. Victaulic Style W77.
 5. Flange Adapters: ASTM A536 ductile iron casting, flat faced, for incorporating flanged components with ANSI Class 125, 150 and 300 bolt hole patterns to a grooved piping system, Victaulic Style 741, W741, or 743.
 6. Grooved joints not allowed on hot water system
 - Steel (Stainless) Pressure-Seal Fittings:
 7. Manufacturers: Subject to compliance with requirements, provide products by one of the following:
 - a. Victaulic Company of America.
 8. Housing: Stainless Steel
 9. O-Rings and Pipe Stop: EPDM.
 10. Tools: Manufacturer's special tool.
 11. Minimum 500-psig (2- 3450 kPa) working-pressure rating at 230 deg F (110 deg C).
- I. Steel Pipe Nipples: ASTM A 733, made of same materials and wall thicknesses as pipe in which they are installed

2.3 JOINING MATERIALS

- A. Pipe-Flange Gasket Materials: Suitable for chemical and thermal conditions of piping system contents.
 1. ASME B16.21, nonmetallic, flat, asbestos free, 1/8-inch (3.2-mm) maximum thickness unless thickness or specific material is indicated.

- a. Full-Face Type: For flat-face, Class 125, cast-iron and cast-bronze flanges.
 - b. Narrow-Face Type: For raised-face, Class 250, cast-iron and steel flanges.
 - c. For chilled water systems – Klinger suitable for glycol use.
 - d. For hot water – Klinger C4500
 - e. For joints of dissimilar metals, provide isolating gaskets, sleeves and washers between flanges, bolts and nuts. Gaskets shall be similar to Dupont Teflon
- B. Flange Bolts, Studs, Nuts and Washers:
1. Bolts and studs shall be chrome-molybdenum bolt stud in accordance with ASTM A 193 grade B7 with full-length threads in accordance ANSI B 31.1. Length shall be sufficient to project beyond nuts three complete threads when joint is made.
 2. Nuts shall be carbon-steel in accordance with ASTM A 194 Grade 2H. Nuts shall be hexagon heavy series type. Threads shall the same as for bolts.
 3. Washers shall be flat, plain, stamped, in accordance with ANSI/ASME B18.22.1.
- C. Ring Spacers and Test Blanks:
1. Provide between flanges where shown on drawing or where necessary to isolate equipment from the piping system, in accordance with B3.1.1, Chapter VI, section 137.2.4. Ring spacers to be replaced by test blanks during hydrostatic testing and/or during chemical cleaning for equipment isolation.
 2. Size and rating to match companion flanges.
- D. Solder Filler Metals: ASTM B 32, lead-free alloys. Include water-flushable flux according to ASTM B 813
- E. Brazing Filler Metals: AWS A5.8, BCuP Series, copper-phosphorus alloys for joining copper with copper; or BAg-1, silver alloy for joining copper with bronze or steel
- F. Welding Filler Metals: Comply with AWS D10.12/D10.12M for welding materials appropriate for wall thickness and chemical analysis of steel pipe being welded
1. Comply with Section II, Part C of the ASME Boiler and Pressure Vessel Code for welding materials appropriate for wall thickness and for chemical analysis of pipe being welded
- 2.4 DIELECTRIC FITTINGS
- A. Description: Combination fitting of copper-alloy and ferrous materials with threaded, solder-joint, plain, or weld-neck end connections that match piping system materials.
- B. In lieu of dielectric fittings, use brass unions to join piping of dissimilar materials.
- 2.5 VALVES
- A. Gate, Globe, Check, Ball, Butterfly, safety relief and balancing Valves,: Comply with requirements specified in Division 23 Section "General-Duty Valves for HVAC Piping."
- B. Automatic Temperature-Control Valves, Actuators, and Sensors: Comply with requirements specified in Division 23 Section "Instrumentation and Control for HVAC."

2.6 AIR CONTROL DEVICES

- A. Manufacturers: Subject to compliance with requirements, provide products by one of the following:
 - 1. Amtrol, Inc.
 - 2. Bell & Gossett Domestic Pump; a division of ITT Industries
- B. Manual Air Vents:
 - 1. Body: Bronze.
 - 2. Internal Parts: Nonferrous.
 - 3. Operator: Screwdriver or thumbscrew.
 - 4. Inlet Connection: NPS 1/2 (DN 15).
 - 5. Discharge Connection: NPS 1/8 (DN 6).
 - 6. CWP Rating: 150 psig (1035 kPa).
 - 7. Maximum Operating Temperature: 225 deg F (107 deg C)
- C. Automatic Air Vents:
 - 1. Body: Bronze or cast iron.
 - 2. Internal Parts: Nonferrous.
 - 3. Operator: Noncorrosive metal float.
 - 4. Inlet Connection: NPS 1/2 (DN 15).
 - 5. Discharge Connection: NPS 1/4 (DN 8).
 - 6. CWP Rating: 150 psig (1035 kPa).
 - 7. Maximum Operating Temperature: 240 deg F (116 deg C)
- D. Expansion Tanks:
 - 1. General:
 - a. Provide as shown on the drawings, a pressurization and air elimination system to accommodate the expanded water generated by the increase in temperature in the water system and to control the increase in pressure at all critical components in the system to the maximum allowable for those components.
 - b. The pressurization and air elimination system shall ensure that all entrained air bubbles in the system shall be eliminated. The only air in the system shall be the permanent sealed in air cushion contained in the pressurization controller component of the system, a diaphragm type extension tank, pre-charged to the minimum operating pressure at the location indicated on the drawing.
 - c. All free air originally contained in the system, and all entrained air bubbles carried by the system water shall be eliminated at all points in the piping system where the capability of water to hold air in solution is lowest (the point of lowest solubility), and as indicated on the drawings. The air separating and elimination component shall separate entrained free air from flowing system water by the creation of a vortex which will allow free air to rise in the center, the point of lowest velocity, to an air elimination valve
 - 2. Diaphragm or Bladder- Type Extension Tanks:
 - a. Tank: Welded steel, rated for 125 psig (860-kPa_ working pressure and 375 deg F (191 deg c)maximum operating temperature. Factory test with taps fabricated and supports installed and labeled according to ASME Boiler and Pressure Vessel Code: Section VIII, Division 1.

- b. Diaphragm or Bladder: Securely sealed into tank to separate air change from system water to maintain required expansion capacity.
 - c. Air-Changed Fittings: Schrader valve, stainless steel with EPDM seats.
 - d. Orientation: Vertical
 - e. Size and capacity as scheduled on drawings
 - f. Features:
 - 1. Integral structural steel supports
 - 2. Base for vertical tanks
 - 3. Gasketed handhole
 - 4. Gasketed manhole
 - 5. All tappings for gauge glass, instrumentation, drain, fill and connections to system: Refer to detail on the drawing
 - 6. Pre-Charged with air to pressure scheduled on drawings
- E. Air Separators:
- 1. Furnish and install air removal device of the size and type shown on the plans. Air and dirt separation devices shall be Taco 4900 series or approved equal, by Spirotherm or Armstrong
 - 2. Air removal devices shall be constructed of steel. It shall be designed, fabricated and stamped per ASME Section VIII Division I with a maximum working pressure of 125 psi at 270 degrees F^o. Units up to three 3-inch in size shall be provided with threaded connections as standard. Units 4-inch and larger shall be provided with flanged system connections as standard.
 - 3. Each air removal device shall be equipped with a brass conical shaped air venting chamber designed to minimize system fluid from fouling the venting assembly. A brass flushing cock shall be located on the side of each separator to facilitate system fast-fill and removal of the floating impurities from the air system interface within the separator. A blown down valve shall be provided by the unit manufacture on the bottom of each unit to allow blow down and cleaning. On units 2 ½" and smaller the valve and all of its fitting shall be 1". On units 3" and larger the valve and all openings shall be 2".
 - 4. The air removal device shall remove air down to 18 microns. The unit manufacture shall provide owner and design engineer third party independent test data certifying that their unit perform to the above standards. Suppliers not providing these independent performance test results will not be acceptable.
 - 5. The air separator shall employ the use of high surface area pall rings to achieve optimal separation of air with minimal pressure drop. The pall rings shall be made of stainless steel. Stainless steel will be the only acceptable material used for suppressing turbulence and increasing surface area for high efficiency air.
 - 6. The unit shall be manufactured with a removable upper head to facilitate removal, inspection, and cleaning of the pall ring basket.

2.7 CHEMICAL TREATMENT

- A. The HVAC Contractor shall hire the services of the building water treatment contractor and provide all required labor and materials. Provide temporary metering and mixing devices as required. The HVAC contractor shall obtain and provide all requirements from the Owner/ water treatment vendor.

2.8 HYDRONIC PIPING SPECIALTIES

A. Y-Pattern Strainers:

1. Chilled Water and Hot Water Systems of Steel Construction:
 - a. Working pressure: To 250 psig, non-shock.
 1. Sizes 1/4 inch to 2 inch: ANSI 250 lb. Class.
 - a) Connections: Threaded.
 - b) Body: Cast iron, ASTM A126, Class B. With machined seat for screen retention. Galvanized as required to match connecting piping.
 - c) Cap: Bronze, gasketed.
 - d) Screen: 20 mesh. 304 stainless steel, ASTM 240. Free area not less than 2-1/2 times inlet area.
 - e) Blowoff outlet: With female NPT tapping.
 - f) Mueller model No. 11 MFCB.
 2. Sizes 2-1/2 inch to 24 inch: Class 250.
 - a) Connections: Flanged.
 - b) Body: Cast iron, ASTM A126, Class B. With machined seat for screen retention. Galvanized as required to match connecting piping.
 - c) Cover flange: Cast iron, ASTM A126, Class B. With machined seat for screen retention. With female tapped NPT blowoff connection. With EPDM O-ring seal.
 - d) Screen to 8 inch: 1/8 inch perforations. 304 stainless steel, ASTM 240. Free area not less than 2-1/2 times inlet area.
 - e) Screen 10 inch and larger: 5/32 inch perforations. 304 stainless steel, ASTM 240. Free area not less than 2-1/2 times inlet area.
 - f) Magnets: Provide magnets for strainers. All 8 inch and larger. At each pump suction. With continuous magnetic field around entire circumference of screen. With removable cast Alnico No. 5 channel magnets with acceptable baskets constructed of magnetic alloy. Secured with stainless steel retaining lugs and threaded rods.
 - g) Blowoff outlet: With female NPT tapping.
 - h) Mueller model No. 752.
 2. Chilled Water and Hot Water Systems of Copper Construction:
 - a. Working pressure: To 250 psig, non-shock.
 1. Sizes 1/4 inch to 2 inch: Class 250
 - a) Connections: Threaded.
 - b) Body: Bronze, ASTM B62. With machined seat for screen retention.
 - c) Cap: Bronze, ASTM B62. With machined seat for screen retention.
 - d) Screen: 20 mesh. 304 stainless steel, ASTM 240. Free area not less than 2-1/2 time inlet area.
 - e) Blowoff outlet: With female NPT tapping.
 - f) Mueller model No. 352M.
 - b. Working pressure to 225 psig Class 150; to 400 psig Class 300:
 1. Sizes 2-1/2 inch to 4 inch:
 - a) Connections: Flanged.

- b) Body: Bronze, ASTM B62 (85-5-5-5) or bronze ASTM B61. Aluminum bronze ASTM A148-90 for sizes 8 inch and larger. With machined seat for screen retention.
 - c) Cover: Material to match body. With machined seat for screen retention.
 - d) Screen to 8 inch: 1/8 inch perforations. 304 stainless steel, ASTM 240. Free area not less than 2-1/2 times inlet area.
 - e) Screen 10 inch and larger: 5/32 inch perforations. 304 stainless steel, ASTM 240. Free area not less than 2-1/2 times inlet area.
 - f) Blowoff outlet: With female NPT tapping.
 - g) Mueller model No. 851 or 851M for Class 150.
 - h) Mueller model. No. 852 for Class 300.
- B. Vacuum Breakers
- 1. For service to 300 psig wsp, similar to Sarco VB 12:
 - a. Size: 1/2 inch.
 - b. Features:
 - 1. All internals renewable without disturbing piping.
 - c. Construction:
 - 1. Cap: Stainless steel, Type 303.
 - 2. Valve: VB 12 stainless steel, Type 303.
 - 3. Valve seat: VB 12 stainless steel, Type 303.
 - 4. Body: VB 12 stainless steel, Type 303.
 - 5. Gasket: VB 12 stainless steel, Type 304.
 - 6. Connections:
 - a) System: 1/2 inch screwed NPT.
 - b) Air inlet: 1/8 inch screwed NPT.
- C. Expansion fittings are specified in Division 23 Section "Expansion Fittings and Loops for HVAC Piping."
- D. Drain Coolers:
- 1. Provide, where indicated on drawings, drain coolers to cool hot blowdown water from humidifiers, using city water
 - 2. Drain coolers shall be equipped with temperature activated cold water valve, vacuum breaker and stainless steel mixing chamber.
 - 3. Provide with appropriate wall mount, floor mount or suspension mount assemblies as required.
 - 4. Drain coolers to be equal to Drane-Kooler by Dri-Steem

PART 3 - EXECUTION

3.1 PIPING APPLICATIONS

- A. Low Temperature Water System, IN EXCESS of 100 psig up to 300 PSIG, except as noted and 40 to 220 deg F supply temperature for hot water and chilled water systems:
- 1. Material shall be steel in accordance with ASTM A 53, Grades A or B.
 - 2. Wall thickness shall be:
 - a. To 2 inch: Schedule 80 with threaded ends or Schedule 40 with socket weld ends.
 - b. 2-1/2 inch to 10 inch: Schedule 40, butt weld ends only.

3. 4 inch and smaller up to 300 PSIG and 100 deg F or 150 PSIG and 250 deg F, Type L, drawn-temper copper tubing, wrought-copper fittings, and brazed joints
 4. No threaded joints are allowed in glycol systems.
 5. Victaulic grooved joints may be used in lieu of welded, flanged or brazed joints on chilled water, and glycol systems (no hot water) for piping 2-1/2 inches and larger.
- B. Makeup-water piping installed aboveground shall be either of the following:
1. Type L, drawn-temper copper tubing, wrought-copper fittings, and brazed joints.
- C. Condensate-Drain Piping: Type , L drawn-temper copper tubing, wrought-copper fittings, and soldered joints.
- D. Blowdown-Drain Piping: Same materials and joining methods as for piping specified for the service in which blowdown drain is installed.
- E. Air-Vent Piping:
1. Inlet: Same as service where installed
 2. Outlet: Same as service where installed.
- F. Provide brass unions for connection of dissimilar metals. Use of bronze valves is not acceptable as a dielectric

3.2 VALVE APPLICATIONS

- A. Install shutoff-duty valves at each branch connection to supply mains, and at supply connection to each piece of equipment.
- B. Install calibrated-orifice, balancing valves at each branch connection to return main.
- C. Install calibrated-orifice, balancing valves in the return pipe of each heating or cooling terminal.

3.3 PIPING INSTALLATIONS

- A. Drawing plans, schematics, and diagrams indicate general location and arrangement of piping systems. Indicate piping locations and arrangements if such were used to size pipe and calculate friction loss, expansion, pump sizing, and other design considerations. Install piping as indicated unless deviations to layout are approved on Coordination Drawings.
- B. Install piping in concealed locations, unless otherwise indicated and except in equipment rooms and service areas.
- C. Install piping indicated to be exposed and piping in equipment rooms and service areas at right angles or parallel to building walls. Diagonal runs are prohibited unless specifically indicated otherwise.
- D. Install piping above accessible ceilings to allow sufficient space for ceiling panel removal.
- E. Install piping to permit valve servicing.
- F. Install piping at indicated slopes.
- G. Install piping free of sags and bends.

- H. Install fittings for changes in direction and branch connections.
- I. Install piping to allow application of insulation.
- J. Select system components with pressure rating equal to or greater than system operating pressure.
- K. Install groups of pipes parallel to each other, spaced to permit applying insulation and servicing of valves.
- L. Install drains, consisting of a tee fitting, NPS 3/4 ball valve, and short NPS 3/4 (DN 20) threaded nipple with cap, at low points in piping system mains and elsewhere as required for system drainage.
- M. Install piping at a uniform grade of 0.2 percent upward in direction of flow.
- N. Reduce pipe sizes using eccentric reducer fitting installed with level side up.
- O. Install branch connections to mains using tee fittings in main pipe, with the branch connected to the bottom of the main pipe. For up-feed risers, connect the branch to the top of the main pipe.
- P. Install valves according to Division 23 Section "General-Duty Valves for HVAC Piping."
- Q. Install unions in piping, NPS 2 (DN 50) and smaller, adjacent to valves, at final connections of equipment, and elsewhere as indicated.
- R. Install flanges or grooved joints on applicable systems, in piping, NPS 2-1/2 (DN 65) and larger, at final connections of equipment and elsewhere as indicated. Slip-on flanges shall be back welded.
- S. Install strainers on inlet side of each control valve, pressure-reducing valve, solenoid valve, in-line pump, and elsewhere as indicated. Install NPS 3/4 (DN 20) nipple and ball valve in blowdown connection of strainers NPS 2 (DN 50) and larger. Match size of strainer blowoff connection for strainers smaller than NPS 2 (DN 50).
- T. Install expansion loops, expansion joints, anchors, and pipe alignment guides as specified in Division 23 Section "Expansion Fittings and Loops for HVAC Piping."
- U. Identify piping as specified in Division 23 Section "Identification for HVAC Piping and Equipment."

3.4 HANGERS AND SUPPORTS

- A. Hanger, support, and anchor devices are specified in Division 23 Section "Hangers and Supports for HVAC Piping and Equipment." Comply with the following requirements for maximum spacing of supports.
- B. Seismic restraints are specified in Division 23 Section "Vibration and Seismic Controls for HVAC Piping and Equipment."
- C. Install the following pipe attachments:
 - 1. Adjustable steel clevis hangers for individual horizontal piping less than 20 feet (6 m) long.
 - 2. Adjustable roller hangers and spring hangers for individual horizontal piping 20 feet (6 m) or longer.
 - 3. Pipe Roller: MSS SP-58, Type 44 for multiple horizontal piping 20 feet (6 m) or longer, supported on a trapeze.

4. Spring hangers to support vertical runs.
 5. Provide copper-clad hangers and supports for hangers and supports in direct contact with copper pipe.
- D. Install hangers for steel piping with the following maximum spacing and minimum rod sizes:
1. NPS 3/4 (DN 20): Maximum span, 6 feet ; minimum rod size, 3/8 inch .
 2. NPS 1 (DN 25): Maximum span, 6 feet ; minimum rod size, 3/8 inch .
 3. NPS 1-1/2 (DN 40): Maximum span, 9 feet (2.7 m); minimum rod size, 3/8 inch (10 mm).
 4. NPS 2 (DN 50): Maximum span, 10 feet (3 m); minimum rod size, 3/8 inch (10 mm).
 5. NPS 2-1/2 (DN 65): Maximum span, 10 feet ; minimum rod size, 1/2 inch .
 6. NPS 3 (DN 80): Maximum span, 10 feet ; minimum rod size, 1/2inch .
 7. NPS 4 (DN 100): Maximum span, 10 feet ; minimum rod size, 5/8 inch .
 8. NPS 6 (DN 150): Maximum span, 10 feet ; minimum rod size, 3/4 inch .
- E. Victaulic Style 107, 07, and W07 rigid couplings may be used on IPS steel piping systems, which meet the support and hanging requirements of ASME B31.1 and B31.9. An adequate number of Victaulic Style 75, 77, or W77 flexible couplings shall also be used to compensate for thermal expansion/contraction of the pipe.
- F. Install hangers for drawn-temper copper piping with the following maximum spacing and minimum rod sizes:
1. NPS 3/4 (DN 20): Maximum span, 5 feet (1.5 m); minimum rod size, 3/8 inch .
 2. NPS 1 (DN 25): Maximum span, 6 feet (1.8 m); minimum rod size, 3/8 inch .
 3. NPS 1-1/2 (DN 40): Maximum span, 8 feet (2.4 m); minimum rod size, 3/8 inch (10 mm).
 4. NPS 2 (DN 50): Maximum span, 8 feet (2.4 m); minimum rod size, 3/8 inch (10 mm).
 5. NPS 2-1/2 (DN 65): Maximum span, 9 feet (2.7 m); minimum rod size, 1/2 inch .
 6. NPS 3 (DN 80): Maximum span, 10 feet (3 m); minimum rod size, 1/2 inch .
- G. Support vertical runs at roof, at each floor, and at 10-foot (3-m) intervals between floors.
- H. Provide additional support at changes in direction, branch piping and runouts over 5 feet and concentrated loads due to valves, strainers and other similar items.
- I. Vertical piping:
1. Base elbow support: Provide bearing plate on structural support, similar to F&S Manufacturing Co. Fig. 720 or 721.
 2. Provide guides at every third floor but not exceed:
 - a. 25 ft for piping to 2 inch.
 - b. 36 ft for piping 2-1/2 inch to 12 inch.
 - c. 50 ft for piping 14 inch and larger.
 3. Top support: Provide special hanger or saddle in horizontal connection and make provisions for expansion.
 4. Intermediate supports: Steel pipe clamp at floor. Bolt and weld to pipe with extension ends bearing on structural steel or bearing plates.
 5. For multiple pipes, coordinate guides, bearing plates and accessory steel.

3.5 PIPE JOINT CONSTRUCTION

- A. Join pipe and fittings according to the following requirements and Division 23 Sections specifying piping systems.
- B. Ream ends of pipes and tubes and remove burrs. Bevel or groove (on applicable systems) plain ends of steel pipe.
- C. Remove scale, slag, dirt, and debris from inside and outside of pipe and fittings before assembly.
- D. Soldered Joints: Apply ASTM B 813, water-flushable flux, unless otherwise indicated, to tube end. Construct joints according to ASTM B 828 or CDA's "Copper Tube Handbook," using lead-free solder alloy complying with ASTM B 32.
- E. Brazed Joints: Construct joints according to AWS's "Brazing Handbook," "Pipe and Tube" Chapter, using copper-phosphorus brazing filler metal complying with AWS A5.8.
- F. Threaded Joints: Thread pipe with tapered pipe threads according to ASME B1.20.1. Cut threads full and clean using sharp dies. Ream threaded pipe ends to remove burrs and restore full ID. Join pipe fittings and valves as follows:
 - 1. Apply appropriate tape or thread compound to external pipe threads unless dry seal threading is specified.
 - 2. Damaged Threads: Do not use pipe or pipe fittings with threads that are corroded or damaged. Do not use pipe sections that have cracked or open welds.
- G. Welded Joints: Construct joints according to AWS D10.12/D10.12M, using qualified processes and welding operators according to Part 1 "Quality Assurance" Article.
- H. Flanged Joints: Select appropriate gasket material, size, type, and thickness for service application. Install gasket concentrically positioned. Use suitable lubricants on bolt threads.
- I. Grooved Joints: Install in accordance with the manufacturer's Victaulic guidelines and recommendations. All grooved couplings, fittings, valves and specialties shall be supplied by a single manufacturer. Grooving tools shall be supplied by the same manufacturer as the grooved components. The gasket style and elastomeric material (grade) shall be verified as suitable for the intended service as specified. Gaskets shall be developed and supplied by the manufacturer. Grooved end shall be clean and free from indentations, projections and roll marks in the area from pipe end to groove. A factory trained field representative shall provide on-site training to contractor's field personnel in the installation of grooved piping products. Factory trained representative shall periodically review the product installation. Contractor shall remove and replace any improperly installed products.
 - 1. Install the Victaulic AGS piping system in accordance with the latest Victaulic installation instructions. Use Victaulic grooving tools with AGS roll sets to groove the pipe. Follow Victaulic guidelines for tool selection and operation. Coupling installation shall be complete when visual metal-to-metal contact is reached. AGS products shall not be installed with standard grooved end pipe or components. Installing AGS products in combination with standard grooved end products could result in joint separation and/or leakage.

3.6 HYDRONIC SPECIALTIES INSTALLATION

- A. Install manual air vents at high points in piping, at heat-transfer coils, and elsewhere as required for system air venting.
- B. Install automatic air vents at high points of system piping in mechanical equipment rooms only. Manual vents at heat-transfer coils and elsewhere as required for air venting.

3.7 TERMINAL EQUIPMENT CONNECTIONS

- A. Sizes for supply and return piping connections shall be the same as or larger than equipment connections.
- B. Install control valves in accessible locations close to connected equipment.
- C. Install bypass piping with globe valve around control valve. If parallel control valves are installed, only one bypass is required.
- D. Install ports for pressure gages and thermometers at coil inlet and outlet connections according to Division 23 Section "Meters and Gages for HVAC Piping."

3.8 FIELD QUALITY CONTROL

- A. Prepare hydronic piping according to ASME B31.9 and as follows:
 - 1. Leave joints, including welds, uninsulated and exposed for examination during test.
 - 2. Provide temporary restraints for expansion joints that cannot sustain reactions due to test pressure. If temporary restraints are impractical, isolate expansion joints from testing.
 - 3. Flush hydronic piping systems with clean water; then remove and clean or replace strainer screens.
 - 4. Isolate equipment from piping. If a valve is used to isolate equipment, its closure shall be capable of sealing against test pressure without damage to valve. Install blinds in flanged joints to isolate equipment.
 - 5. Install safety valve, set at a pressure no more than one-third higher than test pressure, to protect against damage by expanding liquid or other source of overpressure during test.
- B. Perform the following tests on hydronic piping:
 - 1. Use ambient temperature water as a testing medium unless there is risk of damage due to freezing. Another liquid that is safe for workers and compatible with piping may be used.
 - 2. While filling system, use vents installed at high points of system to release air. Use drains installed at low points for complete draining of test liquid.
 - 3. Isolate expansion tanks and determine that hydronic system is full of water.
 - 4. Subject piping system to hydrostatic test pressure that is not less than 1.5 times the system's working pressure. Test pressure shall not exceed maximum pressure for any vessel, pump, valve, or other component in system under test. Verify that stress due to pressure at bottom of vertical runs does not exceed 90 percent of specified minimum yield strength or 1.7 times "SE" value in Appendix A in ASME B31.9, "Building Services Piping." Systems less than 100 psig, hydrostatically test to 150 psig.
 - 5. After hydrostatic test pressure has been applied for at least 4 hours, examine piping, joints, and connections for leakage. Eliminate leaks by tightening,

- repairing, or replacing components, and repeat hydrostatic test until there are no leaks.
6. Prepare written report of testing.
- C. Perform the following before operating the system:
1. Open manual valves fully.
 2. Inspect pumps for proper rotation.
 3. Set makeup pressure-reducing valves for required system pressure.
 4. Inspect air vents at high points of system and determine if all are installed and operating freely (automatic type), or bleed air completely (manual type).
 5. Set temperature controls so all coils are calling for full flow.

END OF SECTION

This page is intentionally left blank.

SECTION 23 21 23

HYDRONIC PUMPS

PART 1 - GENERAL

1.1 RELATED DOCUMENTS

- A. Drawings and general provisions of the Contract, including General and Supplementary Conditions and Division 01 Specification Sections, apply to this Section.
- B. Section 01 81 13 "Sustainable Design Requirements – LEED v4 for Building Design & Construction – New Construction" for sustainable design requirements and detailed sustainable design submittal requirements.
- C. Section 01 74 19 "Construction and Demolition Waste Management and Disposal" for disposal of construction, demolition and packaging waste disposal requirements.

1.2 SUMMARY

- A. This Section includes the following:
 - 1. Close-coupled, in-line centrifugal pumps.
 - 2. Separately coupled, horizontal, end suction centrifugal pumps.
 - 3. Separately coupled, vertical, in-line centrifugal pumps.
 - 4. Automatic condensate pump units.
- B. Sustainable Building Requirements:
 - 1. The Owner requires the Contractor to implement practices and procedures to meet the project's environmental performance goals, which include achieving LEED version 4 **Certified** level Certification. Specific project goals that may impact this area of work include: use of recycled-content materials; use of locally-manufactured materials; use of low-emitting materials; construction waste recycling; and the implementation of a construction indoor air quality management plan. The Contractor shall ensure that the requirements related to these goals, as defined in the Articles below, are implemented to the fullest extent. Substitutions, or other changes to the work proposed by the Contractor or their Subcontractors, shall not be allowed if such changes compromise the aforementioned environmental goals and LEED certification.

1.3 DEFINITIONS

- A. Buna-N: Nitrile rubber.
- B. EPT: Ethylene propylene terpolymer.

1.4 SUBMITTALS

- A. Product Data: Include certified performance curves and rated capacities, operating characteristics, furnished specialties, final impeller dimensions, and accessories for each type of product indicated. Indicate pump's operating point on curves.

- B. Shop Drawings: Show pump layout and connections. Include setting drawings with templates for installing foundation and anchor bolts and other anchorages.
 - 1. Wiring Diagrams: Power, signal, and control wiring.
- C. Operation and Maintenance Data: For pumps to include in emergency, operation, and maintenance manuals.

1.5 QUALITY ASSURANCE

- A. Source Limitations: Obtain hydronic pumps through one source from a single manufacturer.
- B. Product Options: Drawings indicate size, profiles, and dimensional requirements of hydronic pumps and are based on the specific system indicated. Refer to Division 01 Section "Product Requirements."
- C. Electrical Components, Devices, and Accessories: Listed and labeled as defined in NFPA 70, Article 100, by a testing agency acceptable to authorities having jurisdiction, and marked for intended use.
- D. UL Compliance: Comply with UL 778 for motor-operated water pumps.

1.6 DELIVERY, STORAGE, AND HANDLING

- A. Manufacturer's Preparation for Shipping: Clean flanges and exposed machined metal surfaces and treat with anticorrosion compound after assembly and testing. Protect flanges, pipe openings, and nozzles with wooden flange covers or with screwed-in plugs.
- B. Store pumps in dry location.
- C. Retain protective covers for flanges and protective coatings during storage.
- D. Protect bearings and couplings against damage from sand, grit, and other foreign matter.
- E. Comply with pump manufacturer's written rigging instructions.

1.7 COORDINATION

- A. Coordinate size and location of concrete bases. Cast anchor-bolt inserts into bases. Concrete, reinforcement, and formwork requirements are specified in Division 03.

1.8 EXTRA MATERIALS

- A. Furnish extra materials described below that match products installed and that are packaged with protective covering for storage and identified with labels describing contents.
 - 1. Mechanical Seals: One mechanical seal for each pump.

PART 2 - PRODUCTS

2.1 GENERAL PUMP REQUIREMENTS

- A. Pump Units: factory assembled and tested, package pump and motor, single-stage except as noted, and suitable for scheduled conditions of service.
- B. Pump and motor capacities: Minimum as scheduled, suitable for parallel operation. Each motor shall be non-overloading and shall operate over entire head capacity range of pump without exceeding nameplate horsepower rating.
- C. Pump characteristics: Pump curve shall rise continuously from maximum capacity to shutoff. Shut off head shall be approximately 10 percent greater than design head. Operation shall be at or near peak efficiency. Pumps shall be capable of operating at 25 percent beyond design capacity without exceeding breakoff point. Impeller diameter shall not exceed minimum published diameter plus 90 percent of the difference between published maximum and minimum impeller diameters.
- D. Casing: of material specified, with ANSI flanges on inlet and outlet, plugged drain and vent connections, and replaceable bronze wearing rings.
- E. Impeller: Centrifugal type except as noted, totally enclosed, non-over loading, one-piece impeller of material specified, with entire rotating assembly statically, dynamically and hydraulically balanced.
- F. Motor: High efficiency, ODP type conforming to specification section "MOTORS".
- G. Abrasive separator: Except as noted, provide seal finish piping connections with stainless steel abrasive separator.
- H. Bearings: except as noted, grease lubricated or oil lubricated with oiled, moisture and dust resistant housing, minimum 20,000 hour B-10 life (100,000 hour average life) under scheduled conditions of service.
- I. Pumps shall be tested and designed to withstand 1-1/2 times the specified working pressure.
- J. Performance curve derived from certified laboratory tests only.

2.2 MANUFACTURERS

- A. In other Part 2 articles where titles below introduce lists, the following requirements apply to product selection:
 - 1. Manufacturers: Subject to compliance with requirements, provide products by one of the manufacturers specified.

2.3 CLOSE-COUPLED, IN-LINE CENTRIFUGAL PUMPS

- A. Manufacturers:
 - 1. Armstrong Pumps Inc.
 - 2. Bell & Gossett; Div. of ITT Industries.
 - 3. Grundfos Pumps Corporation.
 - 4. PACO Pumps (a division of Grundfos)
 - 5. TACO Pumps.
- B. Description: Factory-assembled and -tested, centrifugal, overhung-impeller, close-coupled, in-line pump as defined in HI 1.1-1.2 and HI 1.3; designed for installation

with pump and motor shafts mounted horizontally or vertically. Rate pump for 175-psig (1204-kPa) minimum working pressure and a continuous water temperature of 225 deg F (107 deg C).

C. Pump Construction:

1. Casing: Radially split, cast iron, with replaceable bronze wear rings, threaded gage tappings at inlet and outlet, and threaded companion-flange connections.
2. Impeller: ASTM B 584, cast bronze; statically and dynamically balanced, keyed to shaft, and secured with a locking cap screw. Trim impeller to match specified performance.
3. Pump Shaft: Steel, with copper-alloy shaft sleeve.
4. Mechanical Seal: Carbon rotating ring against a ceramic seat held by a stainless-steel spring, and Buna-N bellows and gasket. Include water slinger on shaft between motor and seal.
5. Packing Seal: Stuffing box, with a minimum of four rings of graphite-impregnated braided yarn with bronze lantern ring between center two graphite rings, and bronze packing gland.
6. Pump Bearings: Permanently lubricated ball bearings.

- D. Motor: Single speed, with permanently lubricated ball bearings, unless otherwise indicated; and rigidly mounted to pump casing. Comply with requirements in Division 23 Section "Common Motor Requirements for HVAC Equipment."

2.4 SEPARATELY COUPLED, VERTICAL, IN-LINE CENTRIFUGAL PUMPS

A. Manufacturers:

1. Armstrong Pumps Inc.
2. Bell & Gossett; Div. of ITT Industries.
3. PACO Pumps (a division of Grundfos)
4. TACO.

- B. Description: Factory-assembled and -tested, centrifugal, overhung-impeller, separately coupled, in-line pump as defined in HI 1.1-1.2 and HI 1.3; designed for installation with pump and motor shafts mounted vertically. Rate pump 175-psig (1204-kPa) minimum working pressure and a continuous water temperature of 225 deg F (107 deg C).

C. Pump Construction:

1. Casing: Radially split, cast iron, with replaceable bronze wear rings, threaded gage tappings at inlet and outlet, and threaded companion-flange connections.
2. Impeller: ASTM B 584, cast bronze; statically and dynamically balanced, keyed to shaft, and secured with a locking cap screw. Trim impeller to match specified performance.
3. Pump Shaft: Stainless steel.
4. Mechanical Seal: Carbon rotating ring against a ceramic seat held by a stainless-steel spring, and EPT bellows and gasket. Include water slinger on shaft between motor and seal.
5. Packing Seal: Stuffing box, with a minimum of four rings of graphite-impregnated braided yarn with bronze lantern ring between center two graphite rings, and bronze packing gland.

- D. Shaft Coupling: Axially split spacer coupling.

- E. Motor: Single speed, with permanently lubricated ball bearings, unless otherwise indicated; rigidly mounted to pump casing with lifting eye and supporting lugs in motor enclosure. Comply with requirements in Division 23 Section "Common Motor Requirements for HVAC Equipment."

2.5 AUTOMATIC CONDENSATE PUMP UNITS

- A. Manufacturers:
 - 1. Aurora Pump; Division of Pentair Pump Group.
 - 2. Hartell Pumps Div.; Milton Roy Co.
 - 3. Little Giant Pump Co.; Subsidiary of Tecumseh Products Co.
- B. Description: Packaged units with corrosion-resistant pump, plastic tank with cover, and automatic controls. Include factory- or field-installed check valve and a 72-inch- (1800-mm-) minimum, electrical power cord with plug.

2.6 PUMP SPECIALTY FITTINGS

- A. Suction Diffuser: Angle pattern, 175-psig (1204-kPa) pressure rating, cast-iron body and end cap, pump-inlet fitting; with bronze startup and bronze or stainless-steel permanent strainers; bronze or stainless-steel straightening vanes; drain plug; and factory-fabricated support.
- B. Triple-Duty Valve: Angle or straight pattern, 175-psig (1204-kPa) pressure rating, cast-iron body, pump-discharge fitting; with drain plug and bronze-fitted shutoff, balancing, and check valve features. Brass gage ports with integral check valve, and orifice for flow measurement
 - 1. Provide system side shut-off valve for isolation

PART 3 - EXECUTION

3.1 EXAMINATION

- A. Examine equipment foundations and anchor-bolt locations for compliance with requirements for installation tolerances and other conditions affecting performance of work.
- B. Examine roughing-in for piping systems to verify actual locations of piping connections before pump installation.
- C. Examine foundations and inertia bases for suitable conditions where pumps are to be installed.
- D. Proceed with installation only after unsatisfactory conditions have been corrected.

3.2 CONCRETE BASES

- A. Install concrete bases of dimensions indicated for pumps and controllers. Refer to Division 23 Section "Common Work Results for HVAC."
 - 1. Install dowel rods to connect concrete base to concrete floor. Unless otherwise indicated, install dowel rods on 18-inch (450-mm) centers around full perimeter of base.
 - 2. For supported equipment, install epoxy-coated anchor bolts that extend through concrete base and anchor into structural concrete floor.

3. Place and secure anchorage devices. Use setting drawings, templates, diagrams, instructions, and directions furnished with items to be embedded.
 4. Install anchor bolts to elevations required for proper attachment to supported equipment.
- B. Cast-in-place concrete materials and placement requirements are specified in Division 03.

3.3 PUMP INSTALLATION

- A. Install pumps according to manufacturer's written instructions.
- B. Install pumps with access for periodic maintenance including removal of motors, impellers, couplings, and accessories.
- C. Independently support pumps and piping so weight of piping is not supported by pumps and weight of pumps is not supported by piping.
- D. Vibration isolation devices are specified in Division 23 Section "Vibration and Seismic Controls for HVAC Piping and Equipment." Fabricate brackets or supports as required. Hanger and support materials are specified in Division 23 Section "Hangers and Supports for HVAC Piping and Equipment."
- E. Suspend vertically mounted, in-line centrifugal pumps independent of piping. Install pumps with motor and pump shafts vertical. Use continuous-thread hanger rods and spring hangers of sufficient size to support pump weight. Hanger and support materials are specified in Division 23 Section "Hangers and Supports for HVAC Piping and Equipment."
- F. Automatic Condensate Pump Units: Install units for collecting condensate and extend to open drain.

3.4 ALIGNMENT

- A. Align pump and motor shafts and piping connections after setting on foundation, grout has been set and foundation bolts have been tightened, and piping connections have been made.
 1. First alignment check
 - a. The pump to motor shaft alignment must be checked when the pump and motor are first installed on the concrete inertia base.
 - 1) This alignment verification will help determine that the base to centerline of pump shaft is higher than the motor shaft base to centerline height. If not the pump is to be shimmed up.
 - 2) This alignment verification will help determine that the axial alignment of the motor can be performed. If not the motor mounting plate or motor feet will need to be enlarged.
 2. Final alignment
 - a. The final pump to motor shaft alignment can be performed after the following items are completed
 - 1) Pump base grouted and foundation bolts tightened
 - 2) Piping installed and filled.
- B. Comply with pump and coupling manufacturers' written instructions.
- C. Adjust pump and motor shafts for angular and offset alignment.

- D. Manufacturer shall furnish written confirmation / certification that all pumps are properly aligned and operating.

3.5 CONNECTIONS

- A. Piping installation requirements are specified in other Division 23 Sections. Drawings indicate general arrangement of piping, fittings, and specialties.
- B. Install piping adjacent to machine to allow service and maintenance.
- C. Connect piping to pumps. Install valves that are same size as piping connected to pumps.
- D. Install suction and discharge pipe sizes equal to or greater than diameter of pump nozzles.
- E. Install check valve and throttling or triple-duty and shutoff valve on discharge side of pumps.
- F. Install Y-type strainer, suction diffuser and shutoff valve on suction side of pumps.
- G. Install pressure gages on pump suction and discharge, at integral pressure-gage tapping, or install single gage with multiple input selector valve.
- H. Install check valve and gate or ball valve on each condensate pump unit discharge.
- I. Install electrical connections for power, controls, and devices.
- J. Ground equipment according to Division 26 Section "Grounding and Bonding for Electrical Systems."
- K. Connect wiring according to Division 26 Section "Low-Voltage Electrical Power Conductors and Cables."

3.6 STARTUP SERVICE

- A. Engage a factory-authorized service representative to perform startup service.
 - 1. Complete installation and startup checks according to manufacturer's written instructions.
 - 2. Check piping connections for tightness.
 - 3. Clean strainers on suction piping.
 - 4. Perform the following startup checks for each pump before starting:
 - a. Verify bearing lubrication.
 - b. Verify that pump is free to rotate by hand and that pump for handling hot liquid is free to rotate with pump hot and cold. If pump is bound or drags, do not operate until cause of trouble is determined and corrected.
 - c. Disconnect coupling and check motor for proper rotation that matches direction marked on pump casing.
 - d. Verify that pump is rotating in the correct direction.
- B. Starting procedure for pumps with shutoff power not exceeding safe motor power is as follows:
 - 1. Prime pumps by opening suction valves and closing drains, and prepare pumps for operation.
 - 2. Open cooling water-supply valves in cooling water supply to bearings, where applicable.
 - 3. Open cooling water-supply valves if stuffing boxes are water cooled.

4. Open sealing liquid-supply valves for pumps that are so fitted.
 5. Open warm-up valves of pumps handling hot liquids if pumps are not normally kept at operating temperature.
 6. Open circulating line valves if pumps should not be operated against dead shutoff.
 7. Start motors.
 8. Open discharge valves slowly.
 9. Observe leakage from stuffing boxes and adjust sealing liquid valve for proper flow to ensure lubrication of packing. Let packing "run in" before reducing leakage through stuffing boxes; then tighten glands.
 10. Check general mechanical operation of pumps and motors.
 11. Close circulating line valves once there is sufficient flow through pumps to prevent overheating.
- C. When pumps are to be started against closed check valves with discharge shutoff valves open, steps are the same, except open discharge valves before starting motors.

3.7 DEMONSTRATION

- A. Engage a factory-authorized service representative to train Owner's maintenance personnel to adjust, operate, and maintain hydronic pumps. Refer to Division 01 Section "Demonstration and Training."

END OF SECTION

SECTION 23 22 13

STEAM AND CONDENSATE HEATING PIPING

PART 1 - GENERAL

1.1 RELATED DOCUMENTS

- A. Drawings and general provisions of the Contract, including General and Supplementary Conditions and Division 01 Specification Sections, apply to this Section.
- B. Section 01 81 13 "Sustainable Design Requirements – LEED v4 for Building Design & Construction – New Construction" for sustainable design requirements and detailed sustainable design submittal requirements.
- C. Section 01 74 19 "Construction and Demolition Waste Management and Disposal" for disposal of construction, demolition and packaging waste disposal requirements.

1.2 SUMMARY

- A. This Section includes the following for LP and HP steam and condensate piping:
 - 1. Pipe and fittings.
 - 2. Strainers.
 - 3. Safety valves.
 - 4. Pressure-reducing valves.
 - 5. Steam traps.
 - 6. Thermostatic air vents and vacuum breakers.
- B. Sustainable Building Requirements:
 - 1. The Owner requires the Contractor to implement practices and procedures to meet the project's environmental performance goals, which include achieving LEED version 4 **Certified** level Certification. Specific project goals that may impact this area of work include: use of recycled-content materials; use of locally-manufactured materials; use of low-emitting materials; construction waste recycling; and the implementation of a construction indoor air quality management plan. The Contractor shall ensure that the requirements related to these goals, as defined in the Articles below, are implemented to the fullest extent. Substitutions, or other changes to the work proposed by the Contractor or their Subcontractors, shall not be allowed if such changes compromise the aforementioned environmental goals and LEED certification.

1.3 DEFINITIONS

- A. HP Systems: High-pressure piping operating at more than 15 psig (104 kPa) as required by ASME B31.1.
- B. LP Systems: Low-pressure piping operating at 15 psig (104 kPa) or less as required by ASME B31.9

1.4 PERFORMANCE REQUIREMENTS

- A. Components and installation shall be capable of withstanding the following minimum working pressures and temperatures:
1. HP Steam Piping: 125 psig
 2. LP Steam Piping: 15 psig
 3. Condensate Piping: 15 psig at 250 deg F
 4. Makeup-Water Piping: 80 psig at 150 deg F.
 5. Air-Vent and Vacuum-Breaker Piping: Equal to pressure of the piping system to which it is attached.
 6. Safety-Valve-Inlet and -Outlet Piping: Equal to pressure of the piping system to which it is attached.

1.5 SUBMITTALS

- A. Product Data: For each type of the following:
 - 1. Pressure-reducing and safety valve.
 - 2. Steam trap.
 - 3. Air vent and vacuum breaker.
 - 4. Meter.
- B. Shop Drawings: Detail, 3/8 inch equals 1 foot scale, fabrication of pipe anchors, hangers, pipe, multiple pipes, alignment guides, and expansion joints and loops and their attachment to the building structure. Detail locations of anchors, alignment guides, and expansion joints and loops
- C. Prepare general layout drawings as follows:
 - a. Minimum 3/8 inch scale piping layout with fittings, valves and equipment, use single line for pipe sizes 3 inches and smaller and double line for pipe sizes 4 inches and greater.
 - b. Minimum 3/8 inch scale double line layout and sections including for coordination drawings.
 - c. Indicate location of hangers, supports, guides and anchors, expansion joints, loops, drains, vents and sleeves.
- D. Steam piping layout:
 - a. Prepare steam piping shop drawings.
- E. Qualification Data: For Installer.
- F. Welding certificates.
- G. Field quality-control test reports.
- H. Operation and Maintenance Data: For valves, safety valves, pressure-reducing valves, steam traps, air vents, vacuum breakers, and meters to include in emergency, operation, and maintenance manuals.

1.6 QUALITY ASSURANCE

- A. Installer Qualifications:
- B. Steel Support Welding: Qualify processes and operators according to AWS D1.1, "Structural Welding Code - Steel."
- C. Pipe Welding: Qualify processes and operators according to the following:
 - 1. Comply with provisions in ASME B31 Series, "Code for Pressure Piping."
 - 2. Certify that each welder has passed AWS qualification tests for welding processes involved and that certification is current.
- D. ASME Compliance: Comply with ASME B31.1, Power Piping and ASME B31.9, Building Services Piping for materials, products, and installation. Safety valves and pressure vessels shall bear the appropriate ASME label. Fabricate and stamp flash tanks to comply with ASME Boiler and Pressure Vessel Code: Section VIII, Division 1
- E. Steel Pipe Welding:
 - 1. Qualify processes and operators according to ASME Boiler and Pressure Vessel Code: Section IX, "Welding and Brazing Qualifications."

2. Welders shall be qualified for all required pipe sizes, material, wall thickness, and position in accordance with the American Society of Mechanical Engineering (ASME) Section IX, boiler and pressure Vessel Code
3. Copies of the certified welder qualification reports shall be maintained by the responsible welding agency and the company performing the welding, and shall be submitted to the owner and/or Inspector upon request.
4. All defective welds shall be chipped out and repaired at no cost to the Owner, based on procedure to be specified at the time.
5. The contractor shall bear the cost of reinspection of the repaired welds and the inspection of two (2) additional welds, as selected by the owner, for each failed weld.
6. Field Procedures:
 - a. Clean pipe free from rust, scale and oxide.
 - b. Bevel pipe on each end per acceptable procedures.
 - c. Contractor is responsible for preparation of pipe in accordance with ASME B 31.1, Chapter V and for visual inspection during the welding operation and for all required welding examinations with certified welding inspector(s), in accordance with ANSI/AWS B.1.10-86 or latest issue section 3.1, 3.1.1, 3.1.2, and 3.1.3.

PART 2 - PRODUCTS

2.1 STEEL PIPE AND FITTINGS

- A. Steel Pipe: ASTM A 53/A 53M, black steel, plain ends, Type, Grade, and Schedule as indicated in Part 3 piping applications articles.
- B. Cast-Iron Threaded Fittings: ASME B16.4; Classes 125 and 150 as indicated in Part 3 piping applications articles.
- C. Malleable-Iron Threaded Fittings: ASME B16.3; Classes 150 as indicated in Part 3 piping applications articles.
- D. Malleable-Iron Unions: ASME B16.39; Classes 150 and 250 as indicated in Part 3 piping applications articles.
- E. Cast-Iron Threaded Flanges and Flanged Fittings: ASME B16.1, Classes 125 and 250 as indicated in Part 3 piping applications articles; raised ground face, and bolt holes spot faced.
- F. Wrought-Steel Fittings: ASTM A 234/A 234M, wall thickness to match adjoining pipe.
- G. Wrought-Steel Flanges and Flanged Fittings: ASME B16.5, including bolts, nuts, and gaskets of the following material group, end connections, and facings:
 1. Material Group: 1.1.
 2. End Connections: Butt welding.
 3. Facings: Raised face.
- H. Steel Pipe Nipples: ASTM A 733, made of ASTM A 53/A 53M, black steel of same Type, Grade, and Schedule as pipe in which installed.
- I. Stainless-Steel Bellows, Flexible Connectors:
 1. Body: Stainless-steel bellows with woven, flexible, bronze, wire-reinforced, protective jacket.

2. End Connections: Threaded or flanged to match equipment connected.
3. Performance: Capable of 3/4-inch (20-mm) misalignment.
4. CWP Rating: 150-psig (1035-kPa).
5. Maximum Operating Temperature: 250 deg F (121 deg C).

2.2 JOINING MATERIALS

- A. Pipe-Flange Gasket Materials: Suitable for chemical and thermal conditions of piping system contents.
 1. ASME B16.21, nonmetallic, flat, asbestos free, 1/8-inch (3.2-mm) maximum thickness unless thickness or specific material is indicated.
 - a. Full-Face Type: For flat-face, Class 125, cast-iron and cast-bronze flanges.
 - b. Narrow-Face Type: For raised-face, Class 250, cast-iron and steel flanges.
 - c. For high pressure steam and condensate – Garlock, Style 9800 only
 - d. For low pressure steam and condensate - Klinger C4430
 - e. For joints of dissimilar metals, provide isolating gaskets, sleeves and washers between flanges, bolts and nuts. Gaskets shall be similar to Dupont Teflon.
- B. Flange Bolts and Nuts: ASME B18.2.1, carbon steel, unless otherwise indicated.
- C. Welding Filler Metals: Comply with AWS D10.12 (AWS D10.12M) for welding materials appropriate for wall thickness and chemical analysis of steel pipe being welded.
- D. Welding Materials: Comply with Section II, Part C, of ASME Boiler and Pressure Vessel Code for welding materials appropriate for wall thickness and for chemical analysis of pipe being welded.

2.3 DIELECTRIC FITTINGS

- A. Description: Combination fitting of copper alloy and ferrous materials with threaded, solder-joint, plain, or weld-neck end connections that match piping system materials.
- B. Insulating Material: Suitable for system fluid, pressure, and temperature.
- C. Dielectric Unions:
 1. Manufacturers: Subject to compliance with requirements, provide products by one of the following:
 - a. Capitol Manufacturing Company.
 - b. Central Plastics Company.
 - c. Hart Industries, International Inc.
 - d. Watts Water Technologies, Inc.
 - e. Zurn Plumbing Products Group.
 2. Factory-fabricated union assembly, for 250-psig (1725-kPa) minimum working pressure at 180 deg F (82 deg C).

2.4 STRAINERS

- A. Y-Pattern Strainers:
 1. Low pressure steam, low pressure condensate and pumped condensate systems of steel construction 15 psig and below:

- a. Working pressure: To 250 psig wsp @ 406°F. Sizes 1/4 inch to 2 inches: ANSI 250 lb Class:
 - 1) Connections: Threaded.
 - 2) Body:
 - a) Cast iron, ASTM A 126, Class B.
 - b) With machined seat for screen retention.
 - c) Galvanized as required to match connecting piping.
 - 3) Cover: Cast iron gasketed.
 - 4) Screen:
 - a) 3/64 inch perforations.
 - b) 304 stainless steel, ASTM 240.
 - c) Free area not less than 2.5 times inlet area.
 - 5) Blowoff outlet: With female MPT tapping.
 - 6) Mueller Model No. 11 BC.
 - b. Working pressure: For sizes 2-1/2 inches to 12 inches: To 250 psig wsp @ 450°F. For sizes 14 inches to 24 inches: To 200 psig wsp @ 406°F.
 - 1) Connections: Flanged.
 - 2) Body:
 - a) Cast iron, ASTM A 126, Class B.
 - b) With machined seat for screen retention.
 - c) Galvanized as required to match connecting piping.
 - 3) Cover flange:
 - a) Cast iron, ASTM A 126, Class B.
 - b) With machined seat for screen retention.
 - c) With female tapped NPT blowoff connection.
 - d) With EPDM o-ring seal.
 - 4) Screen:
 - a) To 8 inches: 3/64 inch perforations.
 - b) 10 inches and larger: 1/16 inch perforations.
 - c) 304 stainless steel, ASTM 240.
 - d) Free area not less than 2.5 times inlet area.
 - 5) Blowoff outlet: With female NPT tapping.
 - 6) Mueller Model No. 752,
2. High pressure steam and high pressure condensate return systems of steel construction in excess of 15 psig to 100 psig.
 - a. Working pressure: To 450 psig @ 650°F.
 - 1) Sizes 1/4 inch to 2 inches: ANSI Class 300.
 - 2) Connections: Threaded.
 - 3) Body:
 - a) Ductile iron, ASTM A 536, Grade 65-45-12.
 - b) With tapered self-aligning seat.
 - c) Galvanized as required to match connecting piping.
 - 4) Cap: Ductile iron, gasketed.
 - 5) Screen:
 - a) 3/64 inch perforations.
 - b) 304 stainless steel, ASTM 240.
 - c) Free area not less than 2.5 times inlet area.
 - 6) Blowoff outlet: With female NPT tapping.
 - 7) Mueller Model No. 251-DI.
 - b. Working pressure to 150 psig @ 565°F, ANSI Class 150:
 - 1) Sizes 1/2 inch to 12 inches:

- a) Connections: Flanged or butt welded to match piping system.
 - b) Body: Carbon steel, ASTM A 216, Grade WCB. With machined seat for screen retention cover.
 - c) Cover: Carbon steel, ASTM A 216, Grade WCB. With machined seat for screen retention. With female tapped NPT blowoff connection. With non-asbestos gasket.
 - d) Screen: To 4 inches: 1/32 inch perforations. 5 inches and larger: 3/64 inch perforations. 304 stainless steel, ASTM 240. Free area not less than 4 times inlet area.
 - e) Blowoff outlet: With female NPT tapping.
 - f) Mueller Model No. 761 for ANSI Class 150.
3. High pressure steam and high pressure condensate systems of steel construction in excess of 100 psig:
- a. Working pressure to 150 psig @ 565°F, ANSI Class 150 and 300 psig @ 838°F, ANSI Class 300:
 - 1) Sizes 1/2 inch to 12 inches:
 - a) Connections: Flanged to butt welded to match piping system/
 - b) Body: Carbon steel, ASTM A216, Grade WCB. With machined seat for screen retention.
 - c) Cover: Carbon steel, ASTM A216, Grade WCB. With machined seat for screen retention. With female tapped NPT blowoff connection. With non-asbestos gasket.
 - d) Screen: To 4 inches: 1/32 inch perforations. 5 inches and larger: 3/64 inch perforations. 304 stainless steel, ASTM 240. Free area not less than 4 times inlet area.
 - e) Blowoff outlet: With female NPT tapping.
 - f) Mueller Model No. 761 for ANSI Class 150. Mueller model No. 762 for ANSI Class 300.

2.5 SAFETY VALVES

A. Bronze Safety Valves:

1. Manufacturers: Subject to compliance with requirements, provide products by one of the following:
 - a. Armstrong International, Inc.
 - b. Kunkle Valve; a Tyco International Ltd. Company.
 - c. Spirax Sarco, Inc.
 - d. Watts Water Technologies, Inc
 - e. Leslie.
2. Disc Material: Forged copper alloy.
3. End Connections: Threaded inlet and outlet.
4. Spring: Fully enclosed steel spring with adjustable pressure range and positive shutoff, factory set and sealed.
5. Pressure Class: 250.
6. Drip-Pan Elbow: Cast iron and having threaded inlet and outlet with threads complying with ASME B1.20.1.
7. Size and Capacity: As required for equipment according to ASME Boiler and Pressure Vessel Code.

2.6 STEAM PRESSURE-REDUCING STATION

- A. Manufacturers: Subject to compliance with requirements, provide products by one of the following:
 - 1. Spence
 - 2. Spirax- Sarco
- B. Provide single stage PRV stations where indicated and as scheduled on drawings. Each station shall consist of steam pressure reducing valves, strainers, relief valves, isolation gate valves, globe style bypass valves, pressure gauges etc. as detailed.
- C. Regulators shall be single seated, flanged, ASA 250 lb.; cast iron body, stainless steel diaphragm, stainless steel metal disc, stainless steel stem, and carbon steel main spring. Valves shall be normally closed type and designed for dead end service. Steam velocity through the valve shall be limited to 7,000 fpm. Valve shall have stellited seat ring and plug.

2.7 STEAM TRAPS

- A. Thermostatic Traps:
 - 1. Manufacturers: Subject to compliance with requirements, provide products by one of the following:
 - a. Armstrong International, Inc.
 - b. Hoffman Specialty; Division of ITT Industries.
 - c. Spirax Sarco, Inc.
 - 2. Body: Bronze angle-pattern body with integral union tailpiece and screw-in cap.
 - 3. Trap Type: Balanced-pressure.
 - 4. Bellows: Stainless steel or monel.
 - 5. Head and Seat: Replaceable, hardened stainless steel.
 - 6. Maximum allowable Pressure: 125 psig up to 353 deg F.
 - 7. The maximum operating pressure is to be selected for the intended service
- B. Thermodynamic Traps:
 - 1. Manufacturers: Subject to compliance with requirements, provide products by one of the following:
 - a. Armstrong International, Inc.
 - b. Hoffman Specialty; Division of ITT Industries.
 - c. Spirax Sarco, Inc.
 - 2. Body: Stainless steel with screw-in cap.
 - 3. End Connections: Threaded.
 - 4. Disc and Seat: Stainless steel.
 - 5. Maximum allowable Pressure: 600 psig (4140 kPa).to 800 def F.
 - 6. The maximum operating pressure is to be selected for the intended service.
- C. Float and Thermostatic Traps:
 - 1. Manufacturers: Subject to compliance with requirements, provide products by one of the following:
 - a. Armstrong International, Inc.
 - b. Hoffman Specialty; Division of ITT Industries.
 - c. Spirax Sarco, Inc.
 - 2. Body and Bolted Cap: ASTM A 126, cast iron.
 - 3. End Connections: Threaded.
 - 4. Float Mechanism: Replaceable, stainless steel.

5. Head and Seat: Hardened stainless steel.
6. Trap Type: Balanced pressure.
7. Thermostatic Bellows: Stainless steel or monel.
8. Thermostatic air vent capable of withstanding 45 deg F (25 deg C) of superheat and resisting water hammer without sustaining damage.
9. Vacuum Breaker: Thermostatic with phosphor bronze bellows, and stainless steel cage, valve, and seat.
10. Maximum allowable Pressure: 125 psig (860 kPa) up to 450 deg F.
11. The maximum operating pressure is to be selected for the intended service.

D. Inverted Bucket Traps:

1. Manufacturers: Subject to compliance with requirements, provide products by one of the following:
 - a. Armstrong International, Inc.
 - b. Barnes & Jones, Inc.
 - c. Hoffman Specialty; Division of ITT Industries.
 - d. Spirax Sarco, Inc.
2. Body and Cap: Cast iron.
3. End Connections: Threaded.
4. Head and Seat: Stainless steel.
5. Valve Retainer, Lever, and Guide Pin Assembly: Stainless steel.
6. Bucket: Brass or stainless steel.
7. Strainer: Integral stainless-steel inlet strainer within the trap body.
8. Air Vent: Stainless-steel thermostatic vent.
9. Maximum allowable Pressure: 250 psig (1725 kPa).
10. The maximum operating pressure is to be selected for the intended service.

2.8 THERMOSTATIC AIR VENTS AND VACUUM BREAKERS

A. Thermostatic Air Vents:

1. Manufacturers: Subject to compliance with requirements, provide products by one of the following:
 - a. Armstrong International, Inc.
 - b. Hoffman Specialty; Division of ITT Industries.
 - c. Spirax Sarco, Inc.
2. Body: Cast iron, bronze or stainless steel.
3. End Connections: Threaded.
4. Float, Valve, and Seat: Stainless steel.
5. Thermostatic Element: Phosphor bronze bellows in a stainless-steel cage.
6. Maximum allowable Pressure: : 125 psig (861 kPa).
7. The maximum operating pressure is to be selected for the intended service.
8. Maximum Temperature Rating: 350 deg F (177 deg C).

B. Vacuum Breakers:

1. Manufacturers: Subject to compliance with requirements, provide products by one of the following:
 - a. Armstrong International, Inc.
 - b. Hoffman Specialty; Division of ITT Industries.
 - c. Spirax Sarco, Inc.
2. Body: Cast iron, bronze, or stainless steel.
3. End Connections: Threaded.
4. Sealing Ball, Retainer, Spring, and Screen: Stainless steel.
5. O-ring Seal: EPR.

6. Pressure Rating: 125 psig (861 kPa).
7. Maximum Temperature Rating: 350 deg F (177 deg C).

2.9 PIPE FLANGE GASKET MATERIALS

- A. Flange gaskets shall be one-piece ring type 1/16 inch thick (minimum) except as noted, suitable for temperature, pressure (operating and test) and service of system.
 1. For high pressure steam and condensate – Garlock, Style 9800 only
 2. For low pressure steam and condensate - Klinger C4430
 3. For joints of dissimilar metals, provide isolating gaskets, sleeves and washers between flanges, bolts and nuts. Gaskets shall be similar to Dupont Teflon.
 4. Full-Face Type: For flat-face, Class 125, cast iron and cast bronze flanges.
 5. Narrow Face Type: For raised face, class 250, cast iron flanges.

2.10 RING SPACERS AND TEST BLANKS:

- A. Provide between flanges where shown on drawing or where necessary to isolate equipment from the piping system, in accordance with B 3.1.1, Chapter VI, section 137.2.4. Ring spacers to be replaced by test blanks during hydrostatic testing and/or during chemical cleaning for equipment isolation.
- B. Size and rating to match companion flanges.

PART 3 - EXECUTION

3.1 STEAM PIPING APPLICATIONS

- A. High pressure steam system, in excess of 100 psig to 225 psig, total temperature below 450 deg F:
 1. Material shall be steel in accordance with ASTM A53 Grade B seamless.
 2. Wall thickness shall be:
 - a. To 2 inch: Schedule 40, socket weld ends only.
 - b. 2-1/2 inch to 10 inch: Schedule 40, butt weld ends only.
 - c. 12 inch to 24 inch: 0.375 inch wall thickness, butt weld ends only.
- B. High pressure steam system, in excess of 15 psig to 100 psig total temperature not exceeding 450 deg F:
 1. Material shall be steel in accordance with ASTM A53 Grade B seamless.
 2. Wall thickness shall be:
 - a. To 2 inch: Schedule 40, socket weld ends only.
 - b. 2-1/2 inch to 10 inch: Schedule 40, butt weld ends only.
 - c. 12 inch to 24 inch: 0.375 inch wall thickness, butt weld ends only.
- C. Low pressure steam system, 15 psig or below:
 1. Material shall be steel in accordance with ASTM A53 Grade B seamless.
 2. Wall thickness shall be:
 - a. To 2 inch: Schedule 80 with threaded ends, or Schedule 40 with socket welds.
 - b. 2-1/2 inch to 10 inch: Schedule 40, butt weld ends only.
 - c. 12 inch to 24 inch: 0.375 inch wall thickness, butt weld ends only.
- D. High pressure condensate return system, above 100 psig:

1. Material shall be steel in accordance with ASTM A53 Grade B seamless.
 2. Wall thickness shall be:
 - a. To 2 inch: Schedule 80, socket weld ends only.
 - b. 2-1/2 inch to 10 inch: Schedule 80, butt weld ends only.
 - c. 12 inch and larger: Schedule 80, butt weld ends only.
- E. High pressure condensate return system, between 15 psig and 100 psig
1. Material shall be steel in accordance with ASTM A53 Grade B seamless.
 2. Wall thickness shall be:
 - a. To 2 inch: Schedule 80, socket weld ends only.
 - b. 2-1/2 inch to 10 inch: Schedule 80, butt weld ends only.
 - c. 12 inch and larger: 0.375 wall thickness, butt weld ends only.
- F. Low pressure condensate return system, below 15 psig:
1. Material shall be steel in accordance with ASTM A53 Grade B seamless.
 2. Wall thickness shall be:
 - a. To 2 inch: Schedule 80 with threaded ends, or Schedule 40 with socket welds.
 - b. 2-1/2 inch to 10 inch: Schedule 40, butt weld ends only.
 - c. 12 inch and larger: 0.375 wall thickness, butt weld ends only.
- G. Pumped condensate return system:
1. Material shall be steel in accordance with ASTM A53 Grade B seamless.
 2. Wall thickness shall be:
 - a. To 2 inch: Schedule 80 with threaded ends, or Schedule 80 with socket welds.
 - b. 2-1/2 inch to 10 inch: Schedule 40, butt weld ends only.
 - c. 12 inch and larger: 0.375 wall thickness, butt weld ends only.

3.2 ANCILLARY PIPING APPLICATIONS

- A. Air-Vent Piping:
1. Inlet: Same as service where installed.
 2. Outlet: Type K annealed-temper copper tubing with soldered or flared joints.
- B. Vacuum-Breaker Piping: Outlet, same as service where installed.
- C. Safety-Valve-Inlet and -Outlet Piping: Same materials and joining methods as for piping specified for the service in which safety valve is installed.

3.3 LP STEAM-TRAP APPLICATIONS

- A. Thermostatic Traps: Convectors and finned-tube radiation.
- B. Float and Thermostatic Traps: Steam main and riser drip legs, laundry equipment, kitchen equipment, heat exchangers, and heating coils.
- C. As indicated on the drawings.

3.4 HP STEAM-TRAP APPLICATIONS

- A. Thermostatic Traps: Convectors and finned-tube radiation.
- B. Inverted Bucket Traps: Steam main and riser drip legs, and laundry equipment.
- C. Float and Thermostatic Traps: Kitchen equipment, heat exchangers, and heating coils.

- D. Thermodynamic Traps: Steam main and riser drip legs, and heat tracer lines.
- E. As indicated on the drawings

3.5 VALVE APPLICATIONS

- A. General-Duty Valve Applications: Unless otherwise indicated, use the following valve types:
 - 1. Shutoff Duty: Gate and ball valves.
 - 2. Throttling Duty: Globe and ball valves
- B. Install shutoff duty valves at branch connections to steam supply mains, at steam supply connections to equipment, and at the outlet of steam traps.
- C. Install safety valves on pressure-reducing stations and elsewhere as required by ASME Boiler and Pressure Vessel Code. Install safety-valve discharge piping to safe termination point in accordance with building codes , without valves, as indicated on Drawings. Comply with ASME Boiler and Pressure Vessel Code: Section VIII, Division 1, for installation requirements.

3.6 PIPING INSTALLATION

- A. Drawing plans, schematics, and diagrams indicate general location and arrangement of piping systems. Use indicated piping locations and arrangements if such were used to size pipe and calculate friction loss, expansion, and other design considerations. Install piping as indicated unless deviations to layout are approved on Coordination Drawings.
- B. Install piping in concealed locations, unless otherwise indicated and except in equipment rooms and service areas.
- C. Install piping indicated to be exposed and piping in equipment rooms and service areas at right angles or parallel to building walls. Diagonal runs are prohibited unless specifically indicated otherwise.
- D. Install piping above accessible ceilings to allow sufficient space for ceiling panel removal.
- E. Install piping to permit valve servicing.
- F. Install piping free of sags and bends.
- G. Install fittings for changes in direction and branch connections.
- H. Install piping to allow application of insulation.
- I. Select system components with pressure rating equal to or greater than system operating pressure.
- J. Install groups of pipes parallel to each other, spaced to permit applying insulation and servicing of valves.
- K. Install drains, consisting of a tee fitting, NPS 3/4 (DN 20) full port-ball valve, and short NPS 3/4 (DN 20) threaded nipple with cap, at low points in piping system mains and elsewhere as required for system drainage.
- L. Install steam supply piping at a minimum uniform grade of 0.2 percent downward in direction of steam flow.

- M. Install condensate return piping at a minimum uniform grade of 0.4 percent downward in direction of condensate flow.
- N. Reduce pipe sizes using eccentric reducer fitting installed with level side down.
- O. Install branch connections to mains using tee fittings in main pipe, with the branch connected to top of main pipe.
- P. Install valves according to Division 23 Section "General-Duty Valves for HVAC Piping."
- Q. Install unions in piping, NPS 2 (DN 50) and smaller, adjacent to valves, at final connections of equipment, and elsewhere as indicated.
- R. Install flanges in piping, NPS 2-1/2 (DN 65) and larger, at final connections of equipment and elsewhere as indicated.
- S. Install strainers on supply side of control valves, pressure-reducing valves, traps, and elsewhere as indicated. Install NPS 3/4 (DN 20) nipple and full port ball valve in blowdown connection of strainers NPS 2 (DN 50) and larger. Match size of strainer blowoff connection for strainers smaller than NPS 2 (DN 50).
- T. Install expansion loops, expansion joints, anchors, and pipe alignment guides as specified in Division 23 Section "Expansion Fittings and Loops for HVAC Piping."
 - 1. Install piping to permit free expansion and contraction without damaging piping, equipment, or construction.
 - 2. Provide expansion joints, offsets, expansion loops, anchors, guides and supports to permit expansion, within stress limits of ANSI Code for Pressure Piping for temperature range of 40 deg F to minimum of 20 deg F above maximum system temperature.
 - 1) Steam piping shall be cold-sprung.
 - 2) Piping up to 1-1/2 inch: Cold-sprung 100 percent of expansion.
 - 3) Piping 2 inch and larger: Cold-sprung 50 percent of expansion.
 - 3. Install anchors and guides on both sides of expansion loops, zees, etc., to provide safe installation and trouble-free operation
- U. Identify piping as specified in Division 23 Section "Identification for HVAC Piping and Equipment."
- V. Install drip legs at low points and natural drainage points such as ends of mains, bottoms of risers, and ahead of pressure regulators, and control valves.
 - 1. Drips: Provide as follows:
 - a. Steam piping:
 - 1) Maximum 75 foot intervals.
 - 2) At bottom of vertical lines.
 - 3) At rising points in piping.
 - 2. Provide drain valves where condensate may be pocketed.
 - 3. Provide drip points with dirt pockets, the same size as piping, with removable caps. Welded piping shall have ends with flange. Screwed piping shall have caps screwed, made up with graphite.
 - 4. Dirt pockets; Provide full size of riser, 12 inches long at bottom of each riser, end of mains, ends of headers, ahead of pressure regulators, control valves, isolation valves, changes of direction, pipe loops, expansion joints, and as noted
 - 5. Connect drips to condensate return and refer to drip detail.
 - 6. . Pitch steam, condensate return and drip piping for gravity drainage.

- W. Provide three elbow type swing joints on steam and condensate return connections to equipment and piping systems.
- X. .Provide riser shutoff valves in runout to each steam and condensate return riser.
- Y. Install ring spacers and test blanks as required for hydrostatic testing

3.7 STEAM-TRAP INSTALLATION

- A. Install steam traps in accessible locations as close as possible to connected equipment.
- B. Install full-port ball valve, strainer, and union upstream from trap; install union, check valve, and full-port ball valve downstream from trap unless otherwise indicated.

3.8 PRESSURE-REDUCING VALVE INSTALLATION

- A. Install pressure-reducing valves in accessible location for maintenance and inspection.
- B. Install bypass piping around pressure-reducing valves, with globe valve equal in size to area of pressure-reducing valve seat ring, unless otherwise indicated.
- C. Install gate valves on both sides of pressure-reducing valves.
- D. Install unions or flanges on both sides of pressure-reducing valves having threaded- or flanged-end connections respectively.
- E. Install pressure gages on low-pressure side of pressure-reducing valves after the bypass connection according to Division 23 Section "Meters and Gages for HVAC Piping."
- F. On two-stage pressure-reducing stations, install drip trap and pressure gage upstream from second stage pressure-reducing valve
- G. Install strainers upstream for pressure-reducing valve.
- H. Install safety valve downstream from pressure-reducing valve station.
- I. Install noise suppressor as per manufacturers requirements

3.9 SAFETY VALVE INSTALLATION

- A. Install safety valves according to ASME B31.1, Power Piping and ASME B31.9, Building Services Piping.
- B. Pipe safety-valve discharge without valves to atmosphere outside the building.
- C. Install drip-pan elbow fitting adjacent to safety valve and pipe drain connection to nearest floor drain.
- D. Install exhaust head with drain to waste, on vents equal to or larger than NPS 2-1/2 (DN 65).

3.10 HANGERS AND SUPPORTS

- A. Install hangers and supports according to Division 23 Section "Hangers and Supports for HVAC Piping and Equipment." Comply with requirements below for maximum spacing.
- B. Seismic restraints are specified in Division 23 Section "Vibration and Seismic Controls for HVAC Piping and Equipment."
- C. Install the following pipe attachments:
 - 1. Adjustable steel clevis hangers for individual horizontal piping less than 20 feet (6 m) long.
 - 2. Adjustable roller hangers and spring hangers for individual horizontal piping 20 feet (6 m) or longer.
 - 3. Pipe Roller: MSS SP-58, Type 44 for multiple horizontal piping 20 feet (6 m) or longer, supported on a trapeze.
 - 4. Spring hangers to support vertical runs.
- D. Install hangers with the following maximum spacing and minimum rod sizes:
 - 1. NPS 3/4 (DN 20): Maximum span, 9 feet (2.7 m); minimum rod size, 1/4 inch (6.4 mm).
 - 2. NPS 1 (DN 25): Maximum span, 9 feet (2.7 m); minimum rod size, 1/4 inch (6.4 mm).
 - 3. NPS 1-1/2 (DN 40): Maximum span, 12 feet (3.7 m); minimum rod size, 3/8 inch (10 mm).
 - 4. NPS 2 (DN 50): Maximum span, 13 feet (4 m); minimum rod size, 3/8 inch (10 mm).
 - 5. NPS 2-1/2 (DN 65): Maximum span, 14 feet (4.3 m); minimum rod size, 3/8 inch (10 mm).
 - 6. NPS 3 (DN 80): Maximum span, 15 feet (4.6 m); minimum rod size, 3/8 inch (10 mm).
 - 7. NPS 4 (DN 100): Maximum span, 17 feet (5.2 m); minimum rod size, 1/2 inch (13 mm).
 - 8. NPS 6 (DN 150): Maximum span, 21 feet (6.4 m); minimum rod size, 1/2 inch (13 mm).
 - 9. NPS 8 (DN 200): Maximum span, 24 feet (7.3 m); minimum rod size, 5/8 inch (16 mm).
 - 10. NPS 10 (DN 250): Maximum span, 26 feet (8 m); minimum rod size, 3/4 inch (19 mm).
 - 11. NPS 12 (DN 300): Maximum span, 30 feet (9.1 m); minimum rod size, 7/8 inch (22 mm).
- E. Install hangers for drawn-temper copper piping with the following maximum spacing and minimum rod sizes:
 - 1. NPS 1/2 (DN 15): Maximum span, 6 feet (1.2 m); minimum rod size, 1/4 inch (6.4 mm).
 - 2. NPS 3/4 (DN 20): Maximum span, 7 feet (1.5 m); minimum rod size, 1/4 inch (6.4 mm).
 - 3. NPS 1 (DN 25): Maximum span, 8 feet (1.8 m); minimum rod size, 1/4 inch (6.4 mm).
 - 4. NPS 1-1/2 (DN 40): Maximum span, 10 feet (2.4 m); minimum rod size, 3/8 inch (10 mm).
 - 5. NPS 2 (DN 50): Maximum span, 11 feet (2.4 m); minimum rod size, 3/8 inch (10 mm).

6. NPS 2-1/2 (DN 65): Maximum span, 13feet (2.7 m); minimum rod size, 3/8 inch (10 mm).
 7. NPS 3 (DN 80): Maximum span, 14 feet (3 m); minimum rod size, 3/8 inch (10 mm).
- F. Support vertical runs at roof, at each floor, and at 10-foot (3-m) intervals between floors
- G. Vertical piping:
1. Base elbow support: Provide bearing plate on structural support, similar to F&S Manufacturing Co. Fig. 720 or 721.
 2. Provide guides at every third floor but not exceed:
 3. 25 ft for piping to 2 inch.
 4. 36 ft for piping 2-1/2 inch to 12 inch.
 5. 50 ft for piping 14 inch and larger.
 6. Top support: Provide special hanger or saddle in horizontal connection and make provisions for expansion.
 7. Intermediate supports: Steel pipe clamp at floor. Bolt and weld to pipe with extension ends bearing on structural steel or bearing plates.
 8. For multiple pipes, coordinate guides, bearing plates and accessory steel.

3.11 PIPE JOINT CONSTRUCTION

- A. Join pipe and fittings according to the following requirements and Division 23 Sections specifying piping systems.
- B. Ream ends of pipes and tubes and remove burrs. Bevel plain ends of steel pipe.
- C. Remove scale, slag, dirt, and debris from inside and outside of pipe and fittings before assembly.
- D. Threaded Joints: Thread pipe with tapered pipe threads according to ASME B1.20.1. Cut threads full and clean using sharp dies. Ream threaded pipe ends to remove burrs and restore full ID. Join pipe fittings and valves as follows:
1. Apply appropriate tape or thread compound to external pipe threads unless dry seal threading is specified.
 2. Damaged Threads: Do not use pipe or pipe fittings with threads that are corroded or damaged. Do not use pipe sections that have cracked or open welds.
- E. Welded Joints: Construct joints according to AWS D10.12 (AWS D10.12M), using qualified processes and welding operators according to Part 1 "Quality Assurance" Article.
- F. Flanged Joints: Select appropriate gasket material, size, type, and thickness for service application. Install gasket concentrically positioned. Use suitable lubricants on bolt threads.

3.12 TERMINAL EQUIPMENT CONNECTIONS

- A. Size for supply and return piping connections shall be the same as or larger than equipment connections.
- B. Install traps and control valves in accessible locations close to connected equipment.

- C. Install bypass piping with globe valve around control valve. If parallel control valves are installed, only one bypass is required.
- D. Install vacuum breakers downstream from control valve, close to coil inlet connection.
- E. Install a drip leg at coil outlet.
- F. Install ports for pressure and temperature gages at coil inlet connections.
- G. Install a drip leg at coil outlet.
- H. Equipment piping and connections: Provide steam, condensate return, drip and vent piping connections as noted and as recommended by equipment manufacturer. Verify location, number and size of connections.
 - 1. Domestic hot water heaters: Install temperature regulators supplied under Plumbing Sections of the specification.
 - 2. Heating coils: Locate condensate return traps so as not to be subject to freezing.
 - 3. Boiler plant equipment: Refer to Section "Boilers, Feedwater Equipment and Related Apparatus" and to the drawings for requirements.
 - 4. Laboratory, kitchen, laundry and medical equipment: Provide steam, condensate return, drip and vent piping for equipment using steam: As noted and in accordance with requirements of equipment manufacturer.
 - a. Verify exact location, number and size of equipment connections in accordance with drawings and specifications for purchased equipment.
 - b. Provide globe valve in each steam connection.
 - c. In each return connection, provide globe valve at equipment, trap, strainer, upstream of trap and check valve and gate valve on trap discharge.
 - d. Exposed, uninsulated steam, return and drip piping, valves, strainers and traps shall be chromium plated.
 - e. Pressure reducing valves: Provide single-stage, self-contained PRV in steam connections to equipment as noted. Provide strainer at inlet. Exposed pressure reducing valves and strainers shall be chromium plated.
- I. Steam and water mixing unit connections: Provide steam piping connected to unit.
 - 1. In steam connection, provide the following:
 - a. Globe valve.
 - b. Single-stage, self-contained pressure reducing valve. Maximum outlet pressure: 5 psig.
 - c. Strainer at inlet to pressure reducing valve.
 - 2. Exposed piping, valves, pressure valves and strainers shall be chromium plated.
 - 3. Chromium plated valves shall be heat resisting composition cone handle.
- J. Condensate cooler:
 - 1. Connect cooling water to valved outlet provided under Plumbing work. Discharge to floor drain, or as shown on the drawings.
- K. Direct radiation: Provide valves at supply end of each radiation element as noted and in accessible locations. Valves shall be readily accessible. Provide thermostatic traps as noted. Pitch down in direction of steam flow. Provide 1/8 inch key operated air vent at top of each element.
- L. Unit heaters: Provide control valves and traps as noted.

3.13 FIELD QUALITY CONTROL

- A. Prepare steam and condensate piping according to ASME B31.1, "Power Piping" and ASME B31.9, "Building Services Piping," and as follows:
 - 1. Leave joints, including welds, uninsulated and exposed for examination during test.
 - 2. Provide temporary restraints for expansion joints that cannot sustain reactions due to test pressure. If temporary restraints are impractical, isolate expansion joints from testing.
 - 3. Flush system with clean water. Clean strainers.
 - 4. Isolate equipment from piping. If a valve is used to isolate equipment, its closure shall be capable of sealing against test pressure without damage to valve. Install blinds in flanged joints to isolate equipment.
- B. Perform the following tests on steam and condensate piping:
 - 1. Use ambient temperature water as a testing medium unless there is risk of damage due to freezing. Another liquid that is safe for workers and compatible with piping may be used.
 - 2. Subject piping system to hydrostatic test pressure that is not less than 1.5 times the working pressure. Test pressure shall not exceed maximum pressure for any vessel, pump, valve, or other component in system under test. Verify that stress due to pressure at bottom of vertical runs does not exceed 90 percent of specified minimum yield strength.
 - 3. After hydrostatic test pressure has been applied for at least 4 hours, examine piping, joints, and connections for leakage. Eliminate leaks by tightening, repairing, or replacing components, and repeat hydrostatic test until there are no leaks
- C. Prepare written report of testing.

END OF SECTION

SECTION 23 22 23

STEAM CONDENSATE PUMPS

PART 1 - GENERAL

1.1 RELATED DOCUMENTS

- A. Drawings and general provisions of the Contract, including General and Supplementary Conditions and Division 01 Specification Sections, apply to this Section.
- B. Section 01 81 13 "Sustainable Design Requirements – LEED v4 for Building Design & Construction – New Construction" for sustainable design requirements and detailed sustainable design submittal requirements.
- C. Section 01 74 19 "Construction and Demolition Waste Management and Disposal" for disposal of construction, demolition and packaging waste disposal requirements.

1.2 SUMMARY

- A. This Section includes electric-driven steam condensate pumps.
- B. Sustainable Building Requirements:
 - 1. The Owner requires the Contractor to implement practices and procedures to meet the project's environmental performance goals, which include achieving LEED version 4 **Certified** level Certification. Specific project goals that may impact this area of work include: use of recycled-content materials; use of locally-manufactured materials; use of low-emitting materials; construction waste recycling; and the implementation of a construction indoor air quality management plan. The Contractor shall ensure that the requirements related to these goals, as defined in the Articles below, are implemented to the fullest extent. Substitutions, or other changes to the work proposed by the Contractor or their Subcontractors, shall not be allowed if such changes compromise the aforementioned environmental goals and LEED certification.

1.3 SUBMITTALS

- A. Product Data: Include certified performance curves and rated capacities, operating characteristics, furnished specialties, and accessories for each type of product indicated. Indicate pump's operating point on curves. Include receiver capacity and material.
- B. Shop Drawings: Show pump layout and connections. Include setting drawings with templates for installing foundation and anchor bolts and other anchorages.
 - 1. Wiring Diagrams: Power, signal, and control wiring.
- C. Operation and Maintenance Data: For pumps to include in emergency, operation, and maintenance manuals.

1.4 QUALITY ASSURANCE

- A. Source Limitations: Obtain steam condensate pumps through one source from a single manufacturer.
- B. Product Options: Drawings indicate size, profiles, and dimensional requirements of steam condensate pumps and are based on the specific system indicated. Refer to Division 01 Section "Product Requirements."
- C. Electrical Components, Devices, and Accessories: Listed and labeled as defined in NFPA 70, Article 100, by a testing agency acceptable to authorities having jurisdiction, and marked for intended use.
- D. ASME Compliance: Fabricate and label steam condensate pumps to comply with ASME Boiler and Pressure Vessel Code: Section VIII, Division 1.

1.5 DELIVERY, STORAGE, AND HANDLING

- A. Manufacturer's Preparation for Shipping: Clean flanges and exposed machined metal surfaces and treat with anticorrosion compound after assembly and testing. Protect flanges, pipe openings, and nozzles with wooden flange covers or with screwed-in plugs.
- B. Store steam condensate pumps in dry location.
- C. Retain protective covers for flanges and protective coatings during storage.
- D. Protect bearings and couplings against damage from sand, grit, and other foreign matter.
- E. Comply with pump manufacturer's written rigging instructions.

1.6 COORDINATION

- A. Coordinate size and location of concrete bases. Cast anchor-bolt inserts into bases. Concrete, reinforcement, and formwork requirements are specified in Division 03.

PART 2 - PRODUCTS

2.1 MANUFACTURERS

- A. In other Part 2 articles where titles below introduce lists, the following requirements apply to product selection:
 - 1. Manufacturers: Subject to compliance with requirements, provide products by one of the manufacturers specified.

2.2 ELECTRIC-DRIVEN STEAM CONDENSATE PUMPS

- A. Description: Factory-fabricated, packaged, electric-driven pumps; with receiver, pump(s), controls, and accessories suitable for operation with steam condensate.
- B. Configuration: Duplex floor-mounting pumps with receiver and float switches; rated to pump minimum 210 deg F (99 deg C) steam condensate.
 - 1. Manufacturers:
 - a. Domestic Pump; Div. of ITT Industries.
 - b. Spirax Sarco, Inc.

- c. Skidmore
2. Receiver: Floor-mounting close-grained cast iron or welded steel; externally adjustable float switches; with water-level gage, steam condensate thermometer, discharge-pressure gage for each pump, bronze gate valves between receiver and pumps, flanges for pump mounting, and lifting eyebolts.
3. Inlet Strainer: Cast iron with self-cleaning bronze screen, dirt pocket, and cleanout plug on receiver inlet.
4. Pumps: Centrifugal, close coupled, vertical design, permanently aligned, and bronze fitted; with replaceable bronze case rings, stainless-steel shafts, and mechanical seals; mounted on receiver flanges; rated to operate with a minimum of 2 feet (6 kPa) of NPSH.
5. Control Panel: NEMA 250, Type 2 enclosure with hinged door and grounding lug, mounted on pump; factory wired for single external electrical connection; and with the following components within cabinet:
 - a. Motor controller for each pump.
 - b. Electrical pump alternator to operate pumps in lead-lag sequence and allow both pumps to operate on receiver high level.
 - c. Manual lead-lag control to override electrical pump alternator to manually select the lead pump.
 - d. Momentary contact "TEST" push button on cover for each pump.
 - e. Numbered terminal strip.
 - f. Disconnect switch.
 - g. Fused transformer for control circuit.

2.3 MOTORS

- A. Comply with requirements in Division 23 Section "Common Motor Requirements for HVAC Equipment."

PART 3 - EXECUTION

3.1 EXAMINATION

- A. Examine equipment foundations and anchor-bolt locations for compliance with requirements for installation tolerances and other conditions affecting performance of work.
- B. Examine rough installation of steam condensate piping.
- C. Proceed with installation only after unsatisfactory conditions have been corrected.

3.2 INSTALLATION

- A. Install pumps to provide access for periodic maintenance including removing motors, impellers, couplings, and accessories.
- B. Support pumps and piping separately so piping is not supported by pumps.
- C. Install pumps on concrete bases. Anchor pumps to bases using inserts or anchor bolts.
- D. Install thermometers and pressure gages.

3.3 CONNECTIONS

- A. Piping installation requirements are specified in other Division 23 Sections. Drawings indicate general arrangement of piping, fittings, and specialties.
- B. Install piping adjacent to machine to allow service and maintenance.
- C. Install check valve, gate valve, and globe valve at pump discharge connections for each electric-driven pump.
- D. Pipe drain to nearest floor drain for overflow and drain piping connections.
- E. Install full-size vent piping to outdoors, terminating in 180-degree elbow at point above highest steam system connection or as indicated.
- F. Ground equipment according to Division 26 Section "Grounding and Bonding for Electrical Systems."
- G. Connect wiring according to Division 26 Section "Low-Voltage Electrical Power Conductors and Cables."

3.4 STARTUP SERVICE

- A. Verify that steam condensate pumps are installed and connected according to the Contract Documents.
- B. Complete installation and startup checks according to manufacturer's written instructions.
- C. Clean strainers.
- D. Set steam condensate pump controls.
- E. Set pump controls for automatic start, stop, and alarm operation.
- F. Perform the following preventive maintenance operations and checks before starting:
 - 1. Set float switches to operate at proper levels.
 - 2. Set throttling valves on pump discharge for specified flow.
 - 3. Check motors for proper rotation.
 - 4. Test pump controls and demonstrate compliance with requirements.
 - 5. Replace damaged or malfunctioning pump controls and equipment.
 - 6. Verify that pump controls are correct for required application.
- G. Start steam condensate pumps according to manufacturer's written startup instructions.

3.5 DEMONSTRATION

- A. Engage a factory-authorized service representative to train Owner's maintenance personnel to adjust, operate, and maintain steam condensate pumps. Refer to Division 01 Section "Demonstration and Training."

END OF SECTION

SECTION 23 25 00

HVAC WATER TREATMENT

PART 1 - GENERAL

1.1 RELATED DOCUMENTS

- A. Drawings and general provisions of the Contract, including General and Supplementary Conditions and Division 01 Specification Sections, apply to this Section.
- B. Sustainable Building Requirements:
 - 1. The Owner requires the Contractor to implement practices and procedures to meet the project's environmental performance goals, which include achieving LEED version 4 **Certified** level Certification. Specific project goals that may impact this area of work include: use of recycled-content materials; use of locally-manufactured materials; use of low-emitting materials; construction waste recycling; and the implementation of a construction indoor air quality management plan. The Contractor shall ensure that the requirements related to these goals, as defined in the Articles below, are implemented to the fullest extent. Substitutions, or other changes to the work proposed by the Contractor or their Subcontractors, shall not be allowed if such changes compromise the aforementioned environmental goals and LEED certification.

1.2 SUMMARY

- A. This Section includes the following HVAC water-treatment systems
 - 1. Bypass chemical feed equipment and controls
 - 2. Chemical treatment test equipment
 - 3. HVAC water treatment chemicals
 - 4. Glycol feeder makeup package.
- B. Section 01 81 13 "Sustainable Design Requirements – LEED v4 for Building Design & Construction – New Construction" for sustainable design requirements and detailed sustainable design submittal requirements.
- C. Section 01 74 19 "Construction and Demolition Waste Management and Disposal" for disposal of construction, demolition and packaging waste disposal requirements.

1.3 DEFINITIONS

- A. EEPROM: Electrically erasable, programmable read-only memory.
- B. Low Voltage: As defined in NFPA 70 for circuits and equipment operating at less than 50 V or for remote-control, signaling power-limited circuits.
- C. RO: Reverse osmosis.
- D. TDS: Total dissolved solids.
- E. UV: Ultraviolet.

1.4 GENERAL REQUIREMENTS

- A. A single water treatment company shall provide all products and serviced for undivided responsibility throughout the warranty period.
- B. The water treatment company shall be a recognized specialist in the field of industrial water treatment for a minimum of ten (10) years.
- C. The water treatment company shall have knowledgeable and experienced personnel on staff who are chemical engineers or chemists and have been in the field of industrial water treatment for over ten (10) years.
- D. The water treatment company shall have a technical service representative within two (2) hours drive of the job site for the duration of the warranty period.
- E. The water treatment company shall have a well-equipped laboratory managed by qualified personnel.
- F. All products furnished shall be proven reliable and have good proven performances.

1.5 DESCRIPTION OF WATER TREATMENT SERVICE.

- A. Furnish the following as base bid
 - 1. Retain qualified water treatment firm for the following:
 - 2. Supervision of installation of chemical feeding and treatment control equipment, and of initial application of water treatment.
 - a. Supply release title to chemicals for initial cleaning, chemicals for required water treatment, equipment for feeding water treatment chemicals, equipment for control water treatment written instructions for application and control of initial. Cleaning and have water treatment, material Safety Data Sheets for each cleaning and treatment chemical and test equipment and reagents.
 - b. Corrosion test coupons and 4 pass carbon steel apparatus in accordance with ASTM D2688 Method B for all water systems.

1.6 PERFORMANCE REQUIREMENTS

- A. Water quality for HVAC systems shall minimize corrosion, scale buildup, and biological growth for optimum efficiency of HVAC equipment without creating a hazard to operating personnel or the environment.
- B. Base HVAC water treatment on quality of water available at Project site, HVAC system equipment material characteristics and functional performance characteristics, operating personnel capabilities, and requirements and guidelines of authorities having jurisdiction.
- C. Closed hydronic systems, including chilled water and hot-water heating, shall have the following water qualities:
 - 1. pH: Maintain a value within 8.0 to 10.3.
 - 2. Soluble Copper: Maintain a maximum value of 0.10 ppm.
 - 3. TDS: Do not exceed 4,000 mmhs.
 - 4. Ammonia: Maintain a maximum value of less than 2.0 ppm.

5. Microbiological Limits:
 - a. Total Aerobic Plate Count: Maintain a maximum value of 1000 cells/ml.
 - b. Total Anaerobic Plate Count: Maintain a maximum value of 50 cells/ml.
 - c. Nitrate Reducers: Maintain a maximum value of 50 cells/ml.
 - d. Sulfate Reducers: Maintain a maximum value of 50 cells/ml.
 - e. Iron Bacteria: Maintain a maximum value of 50 cells/ml.

1.7 SUBMITTALS

- A. Product Data: Include rated capacities, operating characteristics, furnished specialties, and accessories for the following products:
 1. Bypass feeders.
 2. Water meters.
 3. Chemical test equipment.
 4. Chemical material safety data sheets.
 5. Glycol feeder make-up package.
- B. Shop Drawings: Pretreatment and chemical treatment equipment showing maintenance space required, and piping connections to HVAC systems. Retain subparagraph below if equipment includes wiring.
- C. Field quality-control test reports.
- D. Other Informational Submittals:
 1. Water-Treatment Program: Written sequence of operation on an annual basis for the application equipment required to achieve water quality defined in the "Performance Requirements" Article above.
 2. Water Analysis: Illustrate water quality available at Project site.

1.8 QUALITY ASSURANCE

- A. HVAC Water-Treatment Service Provider Qualifications: An experienced HVAC water-treatment service provider capable of analyzing water qualities, installing water-treatment equipment, and applying water treatment as specified in this Section.
- B. Electrical Components, Devices, and Accessories: Listed and labeled as defined in NFPA 70, Article 100, by a testing agency acceptable to authorities having jurisdiction, and marked for intended use.

1.9 MAINTENANCE SERVICE

- A. Scope of Maintenance Service: Provide chemicals and service program to maintain water conditions required above to inhibit corrosion, scale formation, and biological growth for [heating, hot-water piping] and equipment. Services and chemicals shall be provided for a period of one year from date of Substantial Completion, and shall include the following:
 1. Initial water analysis and HVAC water-treatment recommendations.

2. Startup assistance for Contractor to flush the systems, clean with detergents, and initially fill systems with required chemical treatment prior to operation.
3. Periodic field service and consultation.
4. Customer report charts and log sheets.
5. Laboratory technical analysis.
6. Analyses and reports of all chemical items concerning safety and compliance with government regulations.

PART 2 - PRODUCTS

2.1 MANUFACTURERS

- A. Manufacturers: Subject to compliance with requirements, provide products by one of the following:
1. Ampion Corp.
 2. Anderson Chemical Co, Inc.
 3. Aqua-Chem, Inc.; Cleaver-Brooks Div.
 4. Barclay Chemical Co.; Water Management, Inc.
 5. Boland Trane Services
 6. GE Betz.
 7. GE Osmonics.
 8. H-O-H Chemicals, Inc.
 9. Metro Group. Inc. (The); Metropolitan Refining Div.
 10. ONDEO Nalco Company.
 11. Watcon, Inc.

2.2 MANUAL CHEMICAL-FEED EQUIPMENT

- A. Bypass Feeders: Steel, with corrosion-resistant exterior coating, minimum 3-1/2-inch (89-mm) fill opening in the top, and NPS 3/4 (DN 20) bottom inlet and top side outlet. Quarter turn or threaded fill cap with gasket seal and diaphragm to lock the top on the feeder when exposed to system pressure in the vessel.
1. Capacity: 2 gal. (7.6 L).
 2. Minimum Working Pressure: 125 psig (860 kPa).

2.3 GLYCOL FEEDER MAKEUP PACKAGE

- A. The contractor shall supply and install, as indicated on the plans and in the specifications, a prefabricated, automatic and autonomous make-up package for each glycol system or one system to serve all system with isolation valuing.
- B. The package shall be designed to occupy a minimum amount of floor space to operate on a standard 110V, 60Hz electrical circuit, and to maintain a fill pressure in the glycol system. The pumping assembly shall be mounted in a sturdy steel frame with legs to keep it off the floor. It shall include a pump sized by treatment manufacturer, a motor, a magnetic starter, a pressure tank with a pressure control, a priming valve, a PRV, a shut-off valve and a pressure gauge. It shall be connected to the system with a 1/2" NPT connection.

- C. It shall feature a cut-off and alarm arrangement which will stop the pump in case of excessive pressure, or a low solution level, and active an audible (which can be silenced) and a visual alarm. A 110V shall also be available for a remote alarm. A translucent polyethylene (50) gallon solution container, complete with lid, shall be mounted on the pumping assembly and shall include a strainer and a shut off valve. A glycol solution recovery line shall be piped in from the system relief valve outlet to the solution container, through its lid in such a way that the lid can be removed for filling and mixing.
- D. The make-up package shall be Wessels Model GMP with discharge pressure factory preset and fixed adjustable.

PART 3 - EXECUTION

3.1 WATER ANALYSIS

- A. Perform an analysis of supply water to determine quality of water available at Project site.

3.2 TREATMENT

- A. Provide Treatment for systems as follows:
 - 1. Chilled water and hot water systems, treatment shall be as follows:
 - a. For pH range, refer to Treatment Schedule at end of this section.
 - b. Mixture of Molybdate, Silicate, Polymeric dispersant and Tolytriazole or equivalent non-ferrous inhibitor, maintaining minimum concentration as noted in Treatment schedule at end of this section. The inhibitor shall maintain corrosion of steel and copper below 2 mils per year and 0.2 mils per year respectively.
 - c. Non-oxidizing, non-acidic and non-cationic biocide, glutaraldehyde or approved equal, to control total bacteria count below 1000 colonies per ml.
 - d. Preliminary work required, but is not limited to:
 - 1) Refer to the drawing for additional information and clarification
 - 2) Provide a training manual to include operating and maintenance procedures on equipment, chemical control limits, material safety data sheets, lay-up and start-up procedures.
 - 3) All steps in the following cleaning and treatment procedures must be accomplished in immediate succession with no delay. Provide overtime manpower to accomplish same.
 - 4) Leave all valve trains in place and open for cleaning and treatment procedures and hydrostatic testing.
 - 5) Install drain outlets at deadends, low points and heat exchangers.
 - 6) Insert temporary wire screens of 140 microns or 9/64 inch perforations at chiller inlets. Use a 50 micron bag in the sidestream bag filter.
 - e. Preliminary cleaning procedures:

- 1) Remove all extraneous loose debris, construction material, trash and dirt from piping, filters and all equipment. Remove as much dry material as possible, for this material prevents protective coating transfer to hard to reach portions of the system.
 - 2) Flush water fill line separately to drain. If a new water line has been installed, be sure that rust and debris from it is not washed into the system.
 - 3) Fill the system piping and equipment with water and recirculate for one with the temporary bypasses at open positions.
 - 4) Turn on direct make-up and begin blowing down deadends, low points and y-strainers until water runs "city-water clean" as fast as make-up will allow.
 - 5) Remove all screens and strainers, clean and replace. Flush all temporary bypasses.
 - 6) Add alkaline, non-foaming, non-chlorinated detergent disinfectant plus non-foaming wetting agent to remove cutting oil, excess pipe joint compound, fine solids and other materials at a dosage of 5 lbs per 100 gallons of system water.
 - 7) Recirculate for 4 to 8 hours.
 - 8) Turn on direct make-up and begin flushing all drain outlets, y-strainers, deadends and bypasses until water meets the following parameters: Iron levels within 1 ppm, conductivity within 10 mmhs, orthophosphate within 1 ppm and turbidity within 1 FTU.
 - 9) Isolate tower basins to carry out vacuuming and power spray washing of tower interior. Immediately begin the "pretreatment procedure".
- f. Pretreatment procedure:
- 1) Fill the system piping and equipment with water while adding non-foaming, water- based lay-up inhibitors to protect the piping as per chemical manufacturer's recommended dosage.
 - 2) Recirculate for 2 hours. All heat exchangers and condensers must be off-line and with no heat load.
 - 3) Stop the pumps and secure the system for hydrostatic tests.
 - 4) If the hydrostatic test fails, refill the system and begin pretreatment procedures again from step "g".
 - 5) After successful completion of the hydrostatic test, disconnect all apparatus and secure the system for the resumption of the pretreatment procedure.
 - 6) Begin flushing systems as fast as make-up will allow. Continue until water is "city water clean".
 - 7) Remove all screens, strainers and temporary bypasses. Clean and replace screens and strainers immediately and begin the "passivation procedure".
- g. Passivation Procedure

- 1) Fill the system piping and equipment with water while adding TWICE the regular amount of the maintenance corrosion inhibitor into the water.
 - 2) Recirculate for 24-72 hours.
 - 3) Change the filter bag to a 10 micron high efficiency bag.
 - 4) Keep pressure differential across the bag filter less than 15 psig by washing or replacing the filter bag.
- h. Initial chilled water and hot water system treatment:
- 1) Install corrosion coupons and 5 micron, high-efficiency filter bag in the sidestream filter.
 - 2) Test water for corrosion inhibitor level. Add corrosion inhibitor if necessary to restore the regular control range.
 - 3) Add biocide per water treatment contractor's recommended dosage.
 - 4) Record make-up water meter reading.
- i. Chilled water and hot water maintenance:
- 1) Dose system with corrosion inhibitor based on test results and water meter readings.
 - 2) Remove corrosion coupons on a quarterly basis.
 - 3) Change the filter bags on pressure differential and flow meter readings.
 - 4) Test water monthly for pH, alkalinity, ammonia, hardness, molybdates, silicates, iron, copper, conductivity, total bacteria, turbidity, iron bacteria and sulfur reducing bacteria.
2. Steam and steam condensate systems.
- a. Preliminary work required includes, but is not limited to:
- 1) All steps in the following treatment procedures must be accomplished in immediate succession with no delay. Provide overtime manpower to accomplish same.
 - 2) Install shut off ball valves at the horizontal headers for a temporary connection with hoses, recirculating pumps and tanks.
 - 3) Install vent and drain outlets at the temporary piping.
 - 4) Clean the piping with aqueous cleaning solutions first, followed with steam blowout.
- b. Cleaning procedure:
- 1) Remove all loose mill scale with circulation of plain city water at 3 ft per second or higher (300 gpm in the riser) for 15 minutes.
 - 2) Add a liquid alkaline inhibited chelate cleaner into the piping to create a 5% cleaning solution to remove old mill scale and rust.

- 3) Cleaner shall contain erythorbate as a corrosion inhibitor, sodium gluconate and EDTA as chelates, non-foaming wetting agent and low molecular weight polymeric dispersant.
 - 4) Circulate cleaner for 4 to 8 hours. Test for residual chelate and corrosion inhibitor levels during circulation. Add additional cleaner if necessary to maintain the strength of the cleaner AT 5% and 200 ppm of erythorbate.
 - 5) Drain and flush the loop with city water until it meets the following parameters: Iron levels within 1 ppm, conductivity within 10 mmhs, orthophosphate within 1 ppm and turbidity within 1 FTU.
3. Passivation procedure:
- a. Fill the temporary piping with water while adding alkaline silicate based passivator at an amount of half a gallon to 100 gallons.
 - b. Recirculate the piping for 24 to 48 hours.
 - c. Drain piping and begin cleaning new pipes with steam
4. Humidifiers:
- a. Spray coil and pan types:
 - 1) See treatment schedule at the end of the section for corrosion/scale inhibitor and organic dispesant.
 - 2) For pH range, refer to the treatment schedule at the end of this section.
 - 3) Biocides: if significant slime is detected after operation, provide two different types of treatment for alternating application. Treatment shall be EPA registered for use in air-washers or humidifiers and shall be non-volatile and odorless. Compounds of mercury, copper and arsenic will not be permitted. Treatment should be in accordance with EPA approved label.
 - 4) For external treatment with demineralized and UV sterilizers: See Equipment.

3.3 INSTALLATION

- A. Install water testing equipment on wall near water chemical application equipment.
- B. Bypass Feeders: Install in closed hydronic systems, including [hot-water heating], and equipped with the following:
 1. Install bypass feeder in a bypass circuit around circulating pumps, unless otherwise indicated on Drawings.
 2. Install test-coupon assembly in bypass circuit around circulating pumps, unless otherwise indicated on Drawings.
 3. Install a gate or full-port ball isolation valves on inlet, outlet, and drain below feeder inlet.
 4. Install a swing check on inlet after the isolation valve.

- C. Install glycol makeup system with all required piping and valving.

3.4 CONNECTIONS

- A. Piping installation requirements are specified in other Division 23 Sections. Drawings indicate general arrangement of piping, fittings, and specialties.
- B. Install piping adjacent to equipment to allow service and maintenance.
- C. Make piping connections between HVAC water-treatment equipment and dissimilar-metal piping with dielectric fittings. Dielectric fittings are specified in Division 23 Section "Common Work Results for HVAC."
- D. Install shutoff valves on HVAC water-treatment equipment inlet and outlet. Metal general-duty valves are specified in Division 23 Section "General-Duty Valves for HVAC Piping."
- E. Refer to Division 22 Section "Domestic Water Piping Specialties" for backflow preventers required in makeup water connections to potable-water systems.

3.5 FIELD QUALITY CONTROL

- A. Manufacturer's Field Service: Engage a factory-authorized service representative to inspect, test, and adjust components, assemblies, and equipment installations, including connections. Report results in writing.
- B. Perform tests and inspections and prepare test reports.
 - 1. Manufacturer's Field Service: Engage a factory-authorized service representative to inspect components, assemblies, and equipment installations, including connections, and to assist in testing.
- C. Tests and Inspections:
 - 1. Inspect field-assembled components and equipment installation, including piping and electrical connections.
 - 2. Inspect piping and equipment to determine that systems and equipment have been cleaned, flushed, and filled with water, and are fully operational before introducing chemicals for water-treatment system.
 - 3. Place HVAC water-treatment system into operation and calibrate controls during the preliminary phase of HVAC systems' startup procedures.
 - 4. Do not enclose, cover, or put piping into operation until it is tested and satisfactory test results are achieved.
 - 5. Test for leaks and defects. If testing is performed in segments, submit separate report for each test, complete with diagram of portion of piping tested.
 - 6. Leave uncovered and unconcealed new, altered, extended, and replaced water piping until it has been tested and approved. Expose work that has been covered or concealed before it has been tested and approved.
 - 7. Cap and subject piping to static water pressure of 50 psig (345 kPa) above operating pressure, without exceeding pressure rating of piping system materials. Isolate test source and allow test pressure to stand for four hours. Leaks and loss in test pressure constitute defects.
 - 8. Repair leaks and defects with new materials and retest piping until no leaks exist.

- D. Remove and replace malfunctioning units and retest as specified above.
- E. Comply with ASTM D 3370 and with the following standards:
 - 1. Silica: ASTM D 859.
 - 2. Steam System: ASTM D 1066.
 - 3. Acidity and Alkalinity: ASTM D 1067.
 - 4. Iron: ASTM D 1068.
 - 5. Water Hardness: ASTM D 1126.

3.6 DEMONSTRATION

- A. Engage a factory-authorized service representative to train Owner's maintenance personnel to adjust, operate, and maintain HVAC water-treatment systems and equipment. Refer to Division 01 Section "Demonstration and Training."

END OF SECTION

SECTION 23 31 13

METAL DUCTS

PART 1 - GENERAL

1.1 RELATED DOCUMENTS

- A. Drawings and general provisions of the Contract, including General and Supplementary Conditions and Division 01 Specification Sections, apply to this Section.
- B. Section 01 81 13 "Sustainable Design Requirements – LEED v4 for Building Design & Construction – New Construction" for sustainable design requirements and detailed sustainable design submittal requirements.
- C. Section 01 74 19 "Construction and Demolition Waste Management and Disposal" for disposal of construction, demolition and packaging waste disposal requirements.

1.2 SUMMARY

- A. Section Includes:
 - 1. Single-wall rectangular ducts and fittings.
 - 2. Double-wall rectangular ducts and fittings.
 - 3. Single-wall round and flat-oval ducts and fittings.
 - 4. Double-wall round and flat-oval ducts and fittings.
 - 5. Sheet metal materials.
 - 6. Duct liner.
 - 7. Sealants and gaskets.
 - 8. Hangers and supports.
 - 9. Seismic-restraint devices.
 - 10. Backdraft and pressure relief dampers.
 - 11. Barometric relief dampers.
 - 12. Manual volume dampers.
 - 13. Control dampers.
 - 14. Fire dampers.
 - 15. Smoke dampers.
 - 16. Combination fire and smoke dampers.
 - 17. Turning vanes.
 - 18. Remote damper operators.
 - 19. Duct mounted access doors.

20. Flexible connectors.
21. Flexible ductwork.
22. Antimicrobial coatings
23. UL listed zero clearance kitchen hood exhaust.

B. Related Sections:

1. Division 23 Section "Testing, Adjusting, and Balancing for HVAC" for testing, adjusting, and balancing requirements for metal ducts.
2. Division 23 Section "Noise Control" for double wall ductwork.

C. Sustainable Building Requirements:

1. The Owner requires the Contractor to implement practices and procedures to meet the project's environmental performance goals, which include achieving LEED version 4 **Certified** level Certification. Specific project goals that may impact this area of work include: use of recycled-content materials; use of locally-manufactured materials; use of low-emitting materials; construction waste recycling; and the implementation of a construction indoor air quality management plan. The Contractor shall ensure that the requirements related to these goals, as defined in the Articles below, are implemented to the fullest extent. Substitutions, or other changes to the work proposed by the Contractor or their Subcontractors, shall not be allowed if such changes compromise the aforementioned environmental goals and LEED certification.

1.3 PERFORMANCE REQUIREMENTS

- A. Duct construction, including sheet metal thicknesses, seam and joint construction, reinforcements, and hangers and supports, shall comply with SMACNA's "HVAC Duct Construction Standards - Metal and Flexible, latest edition" and performance requirements and design criteria indicated.

1. DESIGN

STATIC PRESSURE

PRESSURE CLASS

2 IN. W.G

6 IN. W.G.

10 IN. W.G.

OPERATING PRESSURE

UP TO 2 IN. W.G.

OVER 2 IN. UP TO 6 IN. W.G.

OVER 6 IN. UP TO 10 IN. W.G. or

as indicated on plans

- a. Based on the following:

- 1) Single duct system: Static pressure at respective point in ductwork during normal operation.
- 2) Variable volume duct systems: Static pressure at beginning of fan discharge duct.

- b. Description of ductwork pressure class and equipment:

- 1) 6" and greater Duct Class: All supply ductwork from discharge of fans, air handling units, or AC units to inlets of terminal boxes on floor, all outdoor ductwork and all ductwork running through unconditioned spaces. Seal Class "A", leakage class 4 (rectangular metal) or Class 3 (round)

- 2) 6" and greater Duct Class: All return and hood exhaust air ductwork from suction of fans, air handling units or AC units to inlets of terminal boxes on floor. Seal Class "A", leakage class 4 (rectangular metal) or Class 3 (round)
 - 3) 3" Duct Class: All suction and discharge of kitchen exhaust and other exhaust ductwork. Seal Class "B", leakage class 12 *rectangular metal or Class 6 (round)
 - 4) 2" Duct Class and less: All other low pressure ductwork. Seal Class "C", leakage Class 24 (rectangular) or Class 12 (round).
- B. Structural Performance: Duct hangers and supports and seismic restraints shall withstand the effects of gravity and seismic loads and stresses within limits and under conditions described in SMACNA's "HVAC Duct Construction Standards - Metal and Flexible" and SEI/ASCE 7.
1. Seismic Hazard Level A: Seismic force to weight ratio, 0.48.
 2. Seismic Hazard Level B: Seismic force to weight ratio, 0.30.
 3. Seismic Hazard Level C: Seismic force to weight ratio, 0.15.

1.4 SUBMITTALS

- A. Product Data: For each type of product indicated.
- B. Shop Drawings (CAD Generated and Drawn to 3/8 scale):
1. Sheetmetal shop standards shall be compiled directly from the "SMACNA DUCT CONSTRUCTION STANDARDS- Metal and Flexible" manual. Modifications for a specific project, if any, shall be indicated directly on the SMACNA templates. Modified shop standards not taken directly from the SMACNA templates will not be accepted. Any deviations from SMACNA shall be noted.
 2. Fabrication, assembly, and installation, including plans, elevations, sections, components, and attachments to other work.
 3. Factory- and shop-fabricated ducts and fittings.
 4. Duct layout (double line) indicating sizes, transitions, configuration, liner material, and static-pressure classes.
 5. Elevation of top of ducts.
 6. Dimensions of main duct runs from building grid lines.
 7. Sheet metal thicknesses
 8. Fittings.
 9. Reinforcement details and spacing.
 10. Seam and joint construction and sealing
 11. Materials, fabrication, assembly, and spacing of hangers and supports.
 12. Penetrations through fire-rated and other partitions.
 13. Equipment installation based on equipment being used on Project.
 14. Access clearance for all equipment and accessories
 15. Locations for duct accessories, including dampers, turning vanes, and access doors and panels.
 16. Hangers and supports, including methods for duct and building attachment, seismic restraints, and vibration isolation.
 17. Design Calculations: Calculations, including analysis data signed and sealed by the qualified professional engineer responsible for their preparation] for selecting hangers and supports and seismic restraints.

- C. Coordination Drawings: Plans, drawn to scale, on which the following items are shown and coordinated with each other, using input from installers of the items involved:
 - 1. Duct installation in congested spaces, indicating coordination with general construction, building components, and other building services. Indicate proposed changes to duct layout.
 - 2. Suspended ceiling components.
 - 3. Structural members to which duct will be attached.
 - 4. Size and location of initial access modules for acoustical tile.
 - 5. Penetrations of smoke barriers and fire-rated construction.
 - 6. Items penetrating finished ceiling including the following:
 - a. Lighting fixtures.
 - b. Air outlets and inlets.
 - c. Speakers.
 - d. Sprinklers.
 - e. Access panels.
 - f. Perimeter moldings.
- D. Welding certificates.
- E. Field quality-control reports.

1.5 QUALITY ASSURANCE

- A. Welding Qualifications: Qualify procedures and personnel according to AWS D1.1/D1.1M, "Structural Welding Code - Steel," for hangers and supports. AWS D9.1M/D9.1, "Sheet Metal Welding Code," for duct joint and seam welding.
- B. Welding Qualifications: Qualify procedures and personnel according to the following:
 - 1. AWS D1.1/D1.1M, "Structural Welding Code - Steel," for hangers and supports.
 - 2. AWS D9.1M/D9.1, "Sheet Metal Welding Code," for duct joint and seam welding.
- C. NFPA Compliance:
 - 1. NFPA 90A, "Installation of Air conditioning and Ventilating Systems."
 - 2. NFPA 90B, "Installation of Warm Air Heating and Air Conditioning Systems."
 - 3. NFPA 96, "Ventilation Control and Fire Protection of Commercial Cooking Operations."
- D. Indicate compliance with USGBC LEED rating criteria for Indoor environmental quality (IEQ).

PART 2 - PRODUCTS

2.1 SINGLE-WALL RECTANGULAR DUCTS AND FITTINGS

- A. General Fabrication Requirements: Comply with SMACNA's "HVAC Duct Construction Standards - Metal and Flexible", latest edition, based on indicated static-pressure class unless otherwisedicated.
- B. The following fitting connections and duct construction gauges are NOT acceptable
 - 1. Drive slip T-1, T-2 fitting connections
 - 2. 26 gauge ductwork.

- C. Transverse Joints: Select joint types and fabricate according to SMACNA's "HVAC Duct Construction Standards - Metal and Flexible," "Transverse (Girth) Joints," for static-pressure class, applicable sealing requirements, materials involved, duct-support intervals, and other provisions in SMACNA's "HVAC Duct Construction Standards - Metal and Flexible." Fittings and/or joints of two different gauges, connected joint rating shall meet more stringent conditions
1. Use the following SMACNA Transverse (Girth) Joints
 - a. Duct construction as follows for 2" w.g. class:
 - 1) Up to 12" wide use T-6 or T-7
 - 2) 13" to 28" wide use T-11 or T12
 - 3) 29" wide and up use TDC or TDF
 - b. Duct construction as follows for 3" w.g. class:
 - 1) Up to 20" wide use T-6 or T-7
 - 2) 21" to 24" wide use T-11 or T12
 - 3) 25" wide and up use TDC or TDF
 - c. Duct construction as follows for 6" w.g. class:
 - 1) Up to 12" wide use T-6 or T-7
 - 2) 13" to 18" wide use T-11 or T12
 - 3) 19" wide and up use TDC or TDF
- D. Longitudinal Seams: Select seam types and fabricate according to SMACNA's "HVAC Duct Construction Standards - Metal and Flexible "Longitudinal Seams - Rectangular Ducts," for static-pressure class, applicable sealing requirements, materials involved, duct-support intervals, and other provisions in SMACNA's "HVAC Duct Construction Standards - Metal and Flexible."
- E. Elbows, Transitions, Offsets, Branch Connections, and Other Duct Construction: Select types and fabricate according to SMACNA's "HVAC Duct Construction Standards - Metal and Flexible," "Fittings and Other Construction," for static-pressure class, applicable sealing requirements, materials involved, duct-support intervals, and other provisions in SMACNA's "HVAC Duct Construction Standards - Metal and Flexible."
- 2.2 DOUBLE-WALL RECTANGULAR DUCTS AND FITTINGS
- A. Manufacturers: Subject to compliance with requirements, provide products by one of the following:
 1. McGill AirFlow LLC.
 2. Sheet Metal Connectors, Inc.
- B. Rectangular Ducts: Fabricate ducts with indicated dimensions for the inner duct.
- C. The following fitting connections and duct construction gauges are NOT acceptable
 1. Drive slip T-1, T-2 fitting connections
 2. 26 gauge ductwork
- D. Outer Duct: Comply with SMACNA's "HVAC Duct Construction Standards - Metal and Flexible" based on indicated static-pressure class unless otherwise indicated.
- E. Transverse Joints: Select joint types and fabricate according to SMACNA's "HVAC Duct Construction Standards - Metal and Flexible," "Transverse (Girth) Joints," for static-pressure class, applicable sealing requirements, materials involved, duct-support intervals, and other provisions in SMACNA's "HVAC Duct Construction Standards - Metal and Flexible."
1. Use the following SMACNA Transverse (Girth) Joints
 - a. Duct construction as follows for 2" w.g. class:

- 1) Up to 12" wide use T-6 or T-7
 - 2) 13" to 28" wide use T-11 or T12
 - 3) 29" wide and up use TDC or TDF
 - b. Duct construction as follows for 3" w.g. class:
 - 1) Up to 20" wide use T-6 or T-7
 - 2) 21" to 24" wide use T-11 or T12
 - 3) 25" wide and up use TDC or TDF
 - c. Duct construction as follows for 6" w.g. class:
 - 1) Up to 12" wide use T-6 or T-7
 - 2) 13" to 18" wide use T-11 or T12
 - 3) 19" wide and up use TDC or TDF
- F. Longitudinal Seams: Select seam types and fabricate according to SMACNA's "HVAC Duct Construction Standards - Metal and Flexible," "Longitudinal Seams - Rectangular Ducts," for static-pressure class, applicable sealing requirements, materials involved, duct-support intervals, and other provisions in SMACNA's "HVAC Duct Construction Standards - Metal and Flexible."
- G. Interstitial Insulation: Fibrous-glass liner complying with ASTM C 1071, NFPA 90A, or NFPA 90B; and with NAIMA AH124, "Fibrous Glass Duct Liner Standard."
1. Maximum Thermal Conductivity: 0.25 Btu x in./h x sq. ft. x deg F (0.034 W/m x K) at 75 deg F (24 deg C) mean temperature.
 2. Install spacers that position the inner duct at uniform distance from outer duct without compressing insulation.
 3. Coat insulation with antimicrobial coating.
 4. Cover insulation with polyester film complying with UL 181, Class 1.
- H. Inner Duct: Minimum 0.028-inch (0.7-mm) perforated galvanized sheet steel having 3/32-inch- (2.4-mm-) diameter perforations, with overall open area of 23 percent.
- I. Formed-on Transverse Joints (Flanges): Select joint types and fabricate according to SMACNA's "HVAC Duct Construction Standards - Metal and Flexible," "Traverse (Girth) Joints," for static-pressure class, applicable sealing requirements, materials involved, duct-support intervals, and other provisions in SMACNA's "HVAC Duct Construction Standards - Metal and Flexible."
1. Use the following SMACNA Transverse (Girth) Joints
 - a. Duct construction as follows for 2" w.g. class:
 - 1) Up to 12" wide use T-6 or T-7
 - 2) 13" to 28" wide use T-11 or T12
 - 3) 29" wide and up use TDC or TDF
 - b. Duct construction as follows for 3" w.g. class:
 - 1) Up to 20" wide use T-6 or T-7
 - 2) 21" to 24" wide use T-11 or T12
 - 3) 25" wide and up use TDC or TDF
 - c. Duct construction as follows for 6" w.g. class:
 - 1) Up to 12" wide use T-6 or T-7
 - 2) 13" to 18" wide use T-11 or T12

3) 19" wide and up use TDC or TDF

- J. Longitudinal Seams: Select seam types and fabricate according to SMACNA's "HVAC Duct Construction Standards - Metal and Flexible," "Longitudinal Seams - Rectangular Ducts," for static-pressure class, applicable sealing requirements, materials involved, duct-support intervals, and other provisions in SMACNA's "HVAC Duct Construction Standards - Metal and Flexible."

2.3 SINGLE-WALL ROUND DUCTS AND FITTINGS

- A. General Fabrication Requirements: Comply with SMACNA's "HVAC Duct Construction Standards - Metal and Flexible," Round, Oval, and Flexible Duct," based on indicated static-pressure class unless otherwise indicated.
1. Manufacturers: Subject to compliance with requirements, provide products by one of the following:
 - a. Lindab Inc.
 - b. McGill AirFlow LLC.
 - c. SEMCO Incorporated.
 - d. Sheet Metal Connectors, Inc.
 - e. Spiral Manufacturing Co., Inc.
- B. Provide spiral seams for all ducts and fittings.
- C. Transverse Joints: Select joint types and fabricate according to SMACNA's "HVAC Duct Construction Standards - Metal and Flexible," "Transverse Joints - Round Duct," for static-pressure class, applicable sealing requirements, materials involved, duct-support intervals, and other provisions in SMACNA's "HVAC Duct Construction Standards - Metal and Flexible."
1. Transverse Joints in Ducts Larger Than 60 Inches (1524 mm) in Diameter: Flanged.
- D. Longitudinal Seams: Select seam types and fabricate according to SMACNA's "HVAC Duct Construction Standards - Metal and Flexible," Figure 3-1, 1995 edition, Figure 3-2, 2005 edition, "Seams - Round Duct and Fittings," for static-pressure class, applicable sealing requirements, materials involved, duct-support intervals, and other provisions in SMACNA's "HVAC Duct Construction Standards - Metal and Flexible."
1. Fabricate round ducts larger than 90 inches (2286 mm) in diameter with butt-welded longitudinal seams.
 2. Fabricate flat-oval ducts larger than 72 inches (1830 mm) in width (major dimension) with butt-welded longitudinal seams.
- E. Tees and Laterals: Select types and fabricate according to SMACNA's "HVAC Duct Construction Standards - Metal and Flexible," 90 Degree Tees and Laterals," and "Conical Tees," for static-pressure class, applicable sealing requirements, materials involved, duct-support intervals, and other provisions in SMACNA's "HVAC Duct Construction Standards - Metal and Flexible."

2.4 DOUBLE-WALL ROUND DUCTS AND FITTINGS

- A. Manufacturers: Subject to compliance with requirements, provide products by one of the following:
1. Lindab Inc.
 2. McGill AirFlow LLC.
 3. SEMCO Incorporated.
 4. Sheet Metal Connectors, Inc.
- B. Provide spiral seams for all ducts and fittings

- C. Outer Duct: Comply with SMACNA's "HVAC Duct Construction Standards - Metal and Flexible," Chapter 3, "Round, Oval, and Flexible Duct," based on static-pressure class unless otherwise indicated.
 - 1. Transverse Joints: Select joint types and fabricate according to SMACNA's "HVAC Duct Construction Standards - Metal and Flexible," "Transverse Joints - Round Duct," for static-pressure class, applicable sealing requirements, materials involved, duct-support intervals, and other provisions in SMACNA's "HVAC Duct Construction Standards - Metal and Flexible."
 - a. Transverse Joints in Ducts Larger Than 60 Inches (1524 mm) in Diameter: Flanged.
 - 2. Longitudinal Seams: Select seam types and fabricate according to SMACNA's "HVAC Duct Construction Standards - Metal and Flexible," "Seams - Round Duct and Fittings," for static-pressure class, applicable sealing requirements, materials involved, duct-support intervals, and other provisions in SMACNA's "HVAC Duct Construction Standards - Metal and Flexible."
 - a. Fabricate round ducts larger than 90 inches (2286 mm) in diameter with butt-welded longitudinal seams.
 - b. Fabricate flat-oval ducts larger than 72 inches (1830 mm) in width (major dimension) with butt-welded longitudinal seams.
 - 3. Tees and Laterals: Select types and fabricate according to SMACNA's "HVAC Duct Construction Standards - Metal and Flexible," "90 Degree Tees and Laterals," and "Conical Tees," for static-pressure class, applicable sealing requirements, materials involved, duct-support intervals, and other provisions in SMACNA's "HVAC Duct Construction Standards - Metal and Flexible."
- D. Inner Duct: Minimum 0.028-inch (0.7-mm) perforated galvanized sheet steel having 3/32-inch- (2.4-mm-) diameter perforations, with overall open area of 23 percent.
- E. Interstitial Insulation: Fibrous-glass liner complying with ASTM C 1071, NFPA 90A, or NFPA 90B; and with NAIMA AH124, "Fibrous Glass Duct Liner Standard."
 - 1. Maximum Thermal Conductivity: 0.25 Btu x in./h x sq. ft. x deg F (0.034 W/m x K) at 75 deg F (24 deg C) mean temperature.
 - 2. Install spacers that position the inner duct at uniform distance from outer duct without compressing insulation.
 - 3. Coat insulation with antimicrobial coating.
 - 4. Cover insulation with polyester film complying with UL 181, Class 1.

2.5 SHEET METAL MATERIALS

- A. General Material Requirements: Comply with SMACNA's "HVAC Duct Construction Standards - Metal and Flexible", latest edition for acceptable materials, material thicknesses, and duct construction methods unless otherwise indicated. Sheet metal materials shall be free of pitting, seam marks, roller marks, stains, discolorations, and other imperfections.
- B. Exposed Ductwork
 - 1. Where ductwork is indicated to be exposed to view in occupied spaces, provide materials which are free from visual imperfections, including pittings, seam marks, stains, discolorations, and other imperfections. Provide finishes which will allow painting. Provide flat type seams and joints for all exposed duct construction
- C. Galvanized Sheet Steel: Comply with ASTM A 653/A 653M.
 - 1. Galvanized Coating Designation: G60 (Z180).

2. Finishes for Surfaces Exposed to View: Mill phosphatized.
- D. Carbon-Steel Sheets: Comply with ASTM A 1008/A 1008M, with oiled, matte finish for exposed ducts.
- E. Stainless-Steel Sheets: Comply with ASTM A 480/A 480M, Type 304 or 316, as indicated in the "Duct Schedule" Article; cold rolled, annealed, sheet. Exposed surface finish shall be No. 2B, No. 2D, No. 3, or No. 4 as indicated in the "Duct Schedule" Article.
- F. Aluminum Sheets: Comply with ASTM B 209 (ASTM B 209M) Alloy 3003, H14 temper; with mill finish for concealed ducts, and standard, one-side bright finish for duct surfaces exposed to view.
- G. Factory- or Shop-Applied Antimicrobial Coating:
 1. Apply to the interior surface of sheet metal that serve Air Handling Unit's AHU-146 and AHU 147's supply ductwork system an antimicrobial coating that shall form the interior surface of the duct.
 2. Antimicrobial compound shall be tested for efficacy by an NRTL and registered by the EPA for use in HVAC systems.
 3. Coating containing the antimicrobial compound shall have a hardness of 2H, minimum, when tested according to ASTM D 3363.
 4. Surface-Burning Characteristics: Maximum flame-spread index of 25 and maximum smoke-developed index of 50 when tested according to UL 723; certified by an NRTL.
 5. Shop-Applied Coating Color: Black.
- H. Reinforcement Shapes and Plates: ASTM A 36/A 36M, steel plates, shapes, and bars; black and galvanized.
 1. Where black- and galvanized-steel shapes and plates are used to reinforce aluminum ducts, isolate the different metals with butyl rubber, neoprene, or EPDM gasket materials.
- I. Tie Rods: Galvanized steel, 1/4-inch (6-mm) minimum diameter for lengths 36 inches (900 mm) or less; 3/8-inch (10-mm) minimum diameter for lengths longer than 36 inches (900 mm).
- J. Watertight construction where noted with edges bent 1/2 inch for watertight seal. Longitudinal seam sealant shall be similar to 3M Brand No. 800; Alcoa, aluminastic Type C, or solder. Stiffeners shall be plug or spot welded. Transverse joints shall be bolted companion angles with 1/4 inch cadmium plated bolts with 6 inch minimum on centers and gasket.
- K. Air tight construction where noted with longitudinal seams soldered. Stiffeners shall be plug or spot welded. Transverse joints shall be bolted companion angle with 1/4 inch cadmium plated bolts with 6 inch minimum on centers and gasket. Exposed, uninsulated ductwork shall be flush flat seam. Provide airtight concrete, masonry and other construction materials for plenums and shafts only where noted
- L. Flush flat seam ductwork: Provide for all exposed uninsulated ducts and transverse joint detail shall be as indicated. Provide sheet metal 2 gauge numbers heavier than required for pressure classification with normal (standing) seam construction. Provide all joints and seams, smooth and aligned with no projections. For internal reinforcing, at transverse joints and on 2 ft centers, provide on ducts 31 inch to 60 inch wide, single vertical stay at duct midpoint, on ducts 61 inch to 90 inch wide provide 2 vertical stays on duct third (1/3) points and for ducts over 90 inch wide provide 3 vertical stays at ducts quarter (1/4) points. For vertical stays: provide

10 USSG galvanized steel, free of burrs and rough edges with both ends bent and fastened to top and bottom of duct.

2.6 DUCT LINER

- A. Comply with requirements specified in Division 23 Section "NOISE CONTROL" .
- B. Shop Application of Duct Liner: Comply with SMACNA's "HVAC Duct Construction Standards - Metal and Flexible," "Flexible Duct Liner Installation."
 - 1. Adhere a single layer of indicated thickness of duct liner with at least 90 percent adhesive coverage at liner contact surface area. Attaining indicated thickness with multiple layers of duct liner is prohibited.
 - 2. Apply adhesive to transverse edges of liner facing upstream. .
 - 3. Butt transverse joints without gaps, and coat joint with adhesive.
 - 4. Fold and compress liner in corners of rectangular ducts or cut and fit to ensure butted-edge overlapping.
 - 5. Do not apply liner in rectangular ducts with longitudinal joints, except at corners of ducts, unless duct size and dimensions of standard liner make longitudinal joints necessary.
 - 6. Apply adhesive coating on longitudinal seams in ducts with air velocity of 2500 fpm (12.7 m/s).
 - 7. Secure liner with mechanical fasteners 4 inches (100 mm) from corners and at intervals not exceeding 12 inches (300 mm) transversely; at 3 inches (75 mm) from transverse joints and at intervals not exceeding 18 inches (450 mm) longitudinally.
 - 8. Secure transversely oriented liner edges facing the airstream with metal nosings that have either channel or "Z" profiles or are integrally formed from duct wall. Fabricate edge facings at the following locations:
 - a. Fan discharges.
 - b. Intervals of lined duct preceding unlined duct.
 - c. Upstream edges of transverse joints in ducts or where indicated.
 - 9. Secure insulation between perforated sheet metal inner duct of same thickness as specified for outer shell. Use mechanical fasteners that maintain inner duct at uniform distance from outer shell without compressing insulation.
 - a. Sheet Metal Inner Duct Perforations: 3/32-inch (2.4-mm) diameter, with an overall open area of 23 percent.
 - 10. Terminate inner ducts with buildouts attached to fire-damper sleeves, dampers, turning vane assemblies, or other devices. Fabricated buildouts (metal hat sections) or other buildout means are optional; when used, secure buildouts to duct walls with bolts, screws, rivets, or welds.

2.7 SEALANT AND GASKETS

- A. General Sealant and Gasket Requirements: Surface-burning characteristics for sealants and gaskets shall be a maximum flame-spread index of 25 and a maximum smoke-developed index of 50 when tested according to UL 723; certified by an NRTL.
- B. Indicate compliance with USGBC LEED rating criteria for Indoor environmental quality (IEQ)
- C. Two-Part Tape Sealing System:
 - 1. Tape: Woven cotton fiber impregnated with mineral gypsum and modified acrylic/silicone activator to react exothermically with tape to form hard, durable, airtight seal.
 - 2. Tape Width: 3 inches (76 mm).

3. Sealant: Modified styrene acrylic.
 4. Water resistant.
 5. Mold and mildew resistant.
 6. Maximum Static-Pressure Class: 10-inch wg (2500 Pa), positive and negative.
 7. Service: Indoor and outdoor.
 8. Service Temperature: Minus 40 to plus 200 deg F (Minus 40 to plus 93 deg C).
 9. Substrate: Compatible with galvanized sheet steel (both PVC coated and bare), stainless steel, or aluminum.
- D. Water-Based Joint and Seam Sealant:
1. Application Method: Brush on.
 2. Solids Content: Minimum 65 percent.
 3. Shore A Hardness: Minimum 20.
 4. Water resistant.
 5. Mold and mildew resistant.
 6. VOC: Maximum 75 g/L (less water).
 7. Maximum Static-Pressure Class: 10-inch wg (2500 Pa), positive and negative.
 8. Service: Indoor or outdoor.
 9. Substrate: Compatible with galvanized sheet steel (both PVC coated and bare), stainless steel, or aluminum sheets.
- E. Flanged Joint Sealant: Comply with ASTM C 920.
1. General: Single-component, acid-curing, silicone, elastomeric.
 2. Type: S.
 3. Grade: NS.
 4. Class: 25.
 5. Use: O.
- F. Flange Gaskets: Butyl rubber, neoprene, or EPDM polymer with polyisobutylene plasticizer.
- G. Round Duct Joint O-Ring Seals:
1. Seal shall provide maximum leakage class of 3 cfm/100 sq. ft. at 1-inch wg (0.14 L/s per sq. m at 250 Pa) and shall be rated for 10-inch wg (2500-Pa) static-pressure class, positive or negative.
 2. EPDM O-ring to seal in concave bead in coupling or fitting spigot.
 3. Double-lipped, EPDM O-ring seal, mechanically fastened to factory-fabricated couplings and fitting spigots.
- ## 2.8 HANGERS AND SUPPORTS
- A. Hanger Rods for Noncorrosive Environments: Cadmium-plated steel rods and nuts.
- B. Hanger Rods for Corrosive Environments: Electrogalvanized, all-thread rods or galvanized rods with threads painted with zinc-chromate primer after installation.
- C. Strap and Rod Sizes: Comply with SMACNA's "HVAC Duct Construction Standards - Metal and Flexible," "Rectangular Duct Hangers Minimum Size," and "Minimum Hanger Sizes for Round Duct."
- D. Steel Cables for Galvanized-Steel Ducts: Galvanized steel complying with ASTM A 603.

- E. Steel Cables for Stainless-Steel Ducts: Stainless steel complying with ASTM A 492.
- F. Steel Cable End Connections: Cadmium-plated steel assemblies with brackets, swivel, and bolts designed for duct hanger service; with an automatic-locking and clamping device.
- G. Duct Attachments: Sheet metal screws, blind rivets, or self-tapping metal screws; compatible with duct materials.
- H. Trapeze and Riser Supports:
 - 1. Supports for Galvanized-Steel Ducts: Galvanized-steel shapes and plates.
 - 2. Supports for Stainless-Steel Ducts: Stainless-steel shapes and plates.
 - 3. Supports for Aluminum Ducts: Aluminum or galvanized steel coated with zinc chromate.

2.9 SEISMIC-RESTRAINT DEVICES

- A. Manufacturers: Subject to compliance with requirements, provide products by one of the following:
 - 1. Cooper B-Line, Inc.; a division of Cooper Industries.
 - 2. Ductmate Industries, Inc.
 - 3. Hilti Corp.
 - 4. Kinetics Noise Control.
 - 5. Loos & Co.; Cableware Division.
 - 6. Mason Industries.
 - 7. TOLCO; a brand of NIBCO INC.
 - 8. Unistrut Corporation; Tyco International, Ltd.
- B. General Requirements for Restraint Components: Rated strengths, features, and applications shall be as defined in reports by an evaluation service member of the ICC Evaluation Service.
 - 1. Structural Safety Factor: Allowable strength in tension, shear, and pullout force of components shall be at least four times the maximum seismic forces to which they will be subjected.
- C. Channel Support System: Shop- or field-fabricated support assembly made of slotted steel channels rated in tension, compression, and torsion forces and with accessories for attachment to braced component at one end and to building structure at the other end. Include matching components and corrosion-resistant coating.
- D. Restraint Cables: ASTM A 603, galvanized-steel cables with end connections made of cadmium-plated steel assemblies with brackets, swivel, and bolts designed for restraining cable service; and with an automatic-locking and clamping device or double-cable clips.
- E. Hanger Rod Stiffener: Steel tube or steel slotted-support-system sleeve with internally bolted connections to hanger rod.
- F. Mechanical Anchor Bolts: Drilled-in and stud-wedge or female-wedge type. Select anchor bolts with strength required for anchor and as tested according to ASTM E 488.

2.10 BACKDRAFT AND PRESSURE RELIEF DAMPERS

- A. Manufacturers: Subject to compliance with requirements, provide products by one of the following:
 - 1. Greenheck Fan Corporation.
 - 2. Pottorff; a division of PCI Industries, Inc.
 - 3. Ruskin Company.
- B. Description: Gravity balanced.
- C. Maximum Air Velocity: 2000 fpm (10 m/s).
- D. Maximum System Pressure: 2-inch wg (0.5 kPa).
- E. Frame: 0.052-inch- (1.3-mm-) thick, galvanized sheet steel, with welded corners and mounting flange.
- F. Blades: Multiple single-piece blades, center-pivoted, maximum 6-inch (150-mm) width, 0.050-inch- (1.2-mm-) thick aluminum sheet with sealed edges.
- G. Blade Action: Parallel.
- H. Blade Seals: Extruded vinyl, mechanically locked.
- I. Blade Axles:
 - 1. Material: Non-metallic.
 - 2. Diameter: 0.20 inch (5 mm).
- J. Tie Bars and Brackets: Aluminum.
- K. Return Spring: Adjustable tension.
- L. Bearings: Synthetic pivot bushings.
- M. Accessories:
 - 1. Counterweights and spring-assist kits for vertical airflow installations.
- N. Sleeve: Minimum 16-gage thickness.

2.11 MANUAL VOLUME DAMPERS

- A. Dampers to be the same as duct construction.
- B. Standard, Steel, Manual Volume Dampers:
 - 1. Manufacturers: Subject to compliance with requirements, provide products by one of the following:
 - a. Pottorff; a division of PCI Industries, Inc.
 - b. Ruskin Company.
 - 2. Standard leakage rating, with linkage outside airstream.
 - 3. Suitable for horizontal or vertical applications.
 - 4. Frames:
 - a. Hat-shaped, galvanized -steel channels, 0.064-inch (1.62-mm) minimum thickness.
 - b. Mitered and welded corners.
 - c. Flanges for attaching to walls and flangeless frames for installing in ducts.
 - 5. Blades:
 - a. Multiple or single blade.
 - b. Provide single blade dampers up to 6 inch width and opposed multiblade dampers above 6 inches in width.

- c. Parallel- or opposed-blade design.
 - d. Stiffen damper blades for stability.
 - e. Galvanized-steel, 0.064 inch (1.62 mm) thick (16 ga.).
 6. Blade Axles: Galvanized steel.
 7. Bearings:
 - a. Molded synthetic.
 - b. Dampers in ducts with pressure classes of 3-inch wg (750 Pa) or less shall have axles full length of damper blades and bearings at both ends of operating shaft.
 8. Tie Bars and Brackets: Galvanized steel.
- C. Standard, Aluminum, Manual Volume Dampers:
 1. Manufacturers: Subject to compliance with requirements, provide products by one of the following:
 - a. Pottorff; a division of PCI Industries, Inc.
 - b. Ruskin Company.
 2. Standard leakage rating, with linkage outside airstream.
 3. Suitable for horizontal or vertical applications.
 4. Frames: Hat-shaped, 0.10-inch- (2.5-mm-) thick, aluminum sheet channels; frames with flanges for attaching to walls and flangeless frames for installing in ducts.
 5. Blades:
 - a. Multiple or single blade.
 - b. Parallel- or opposed-blade design.
 - c. Stiffen damper blades for stability.
 - d. Roll-Formed Aluminum Blades: 0.10-inch- (2.5-mm-) thick aluminum sheet.
 - e. Extruded-Aluminum Blades: 0.050-inch- (1.2-mm-) thick extruded aluminum.
 6. Blade Axles: Nonferrous metal.
 7. Bearings:
 - a. Molded synthetic.
 - b. Dampers in ducts with pressure classes of 3-inch wg (750 Pa) or less shall have axles full length of damper blades and bearings at both ends of operating shaft.
 8. Tie Bars and Brackets: Aluminum.
- D. Low-Leakage, Steel, Manual Volume Dampers:
 1. Manufacturers: Subject to compliance with requirements, provide products by one of the following:
 - a. Pottorff; a division of PCI Industries, Inc.
 - b. Ruskin Company.
 2. Low-leakage rating, with linkage outside airstream, and bearing AMCA's Certified Ratings Seal for both air performance and air leakage.
 3. Suitable for horizontal or vertical applications.
 4. Frames:
 - a. Hat shaped.
 - b. Galvanized-steel channels, 0.064 inch (1.62 mm) thick.
 - c. Mitered and welded corners.
 - d. Flanges for attaching to walls and flangeless frames for installing in ducts.
 5. Blades:
 - a. Multiple or single blade.

- b. Parallel- or opposed-blade design.
 - c. Stiffen damper blades for stability.
 - d. Galvanized, roll-formed steel, 0.064 inch (1.62 mm) thick. (16 ga.).
 6. Blade Axles: Galvanized steel.
 7. Bearings:
 - a. Molded synthetic.
 - b. Dampers in ducts with pressure classes of 3-inch wg (750 Pa) or less shall have axles full length of damper blades and bearings at both ends of operating shaft.
 8. Blade Seals: Neoprene.
 9. Jamb Seals: Cambered aluminum.
 10. Tie Bars and Brackets: Galvanized steel.
 11. Accessories:
 - a. Include locking device to hold single-blade dampers in a fixed position without vibration.
- E. Low-Leakage, Aluminum, Manual Volume Dampers:
 1. Manufacturers: Subject to compliance with requirements, provide products by one of the following:
 - a. Ruskin Company.
 - b. Trox USA Inc.
 2. Low-leakage rating, with linkage outside airstream, and bearing AMCA's Certified Ratings Seal for both air performance and air leakage.
 3. Suitable for horizontal or vertical applications.
 4. Frames: Hat-shaped, 0.10-inch- (2.5-mm-) thick, aluminum sheet channels; frames with flanges for attaching to walls and flangeless frames for installing in ducts.
 5. Blades:
 - a. Multiple or single blade.
 - b. Parallel- or opposed-blade design.
 - c. Roll-Formed Aluminum Blades: 0.10-inch- (2.5-mm-) thick aluminum sheet.
 - d. Extruded-Aluminum Blades: 0.050-inch- (1.2-mm-) thick extruded aluminum.
 6. Blade Axles: Stainless steel.
 7. Bearings:
 - a. Molded synthetic.
 - b. Dampers in ducts with pressure classes of 3-inch wg (750 Pa) or less shall have axles full length of damper blades and bearings at both ends of operating shaft.
 8. Blade Seals: Neoprene.
 9. Jamb Seals: Cambered aluminum.
 10. Tie Bars and Brackets: Aluminum.
 11. Accessories:
 - a. Include locking device to hold single-blade dampers in a fixed position without vibration.
- F. Jackshaft:
 1. Size: 1-inch (25-mm) diameter.
 2. Material: Galvanized-steel pipe rotating within pipe-bearing assembly mounted on supports at each mullion and at each end of multiple-damper assemblies.

3. Length and Number of Mountings: As required to connect linkage of each damper in multiple-damper assembly.

G. Damper Hardware:

1. Zinc-plated, die-cast core with dial and handle made of 3/32-inch- (2.4-mm-) thick zinc-plated steel, and a 3/4-inch (19-mm) hexagon locking nut.
2. Include center hole to suit damper operating-rod size.
3. Include elevated platform for insulated duct mounting.

2.12 CONTROL DAMPERS

A. Manufacturers: Subject to compliance with requirements, provide products by one of the following:

1. Greenheck Fan Corporation.
2. Ruskin Company.

B. Low-leakage rating, with linkage outside airstream, and bearing AMCA's Certified Ratings Seal for both air performance and air leakage. All dampers serving outside air connections/service shall be internal insulated type.

C. Dampers to be the same as duct construction.

D. For internally lined ductwork: Provide 2 internal saddles to protect lining.

E. Frames:

1. Hat shaped.
2. Galvanized-steel channels, 0.064 inch (1.62 mm) thick.
3. Mitered and welded corners.

F. Blades:

1. Provide airfoil blades.
2. Multiple blade with maximum blade width of 8 inches (200 mm).
3. Provide dampers with parallel blades for 2 position control and opposed blades for modulating control.
4. Parallel- and opposed-blade design.
5. Galvanized steel.
6. 0.064 inch (1.62 mm) thick.
7. Blade Edging: Closed-cell neoprene edging.
8. Blade Edging: Inflatable seal blade edging, or replaceable rubber seals.

G. Blade Axles: 1/2-inch- (13-mm-) diameter; nonferrous metal; blade-linkage hardware of zinc-plated steel and brass; ends sealed against blade bearings.

1. Operating Temperature Range: From minus 40 to plus 200 deg F (minus 40 to plus 93 deg C).

H. Bearings:

1. Molded synthetic.
2. Dampers in ducts with pressure classes of 3-inch wg (750 Pa) or less shall have axles full length of damper blades and bearings at both ends of operating shaft.
3. Thrust bearings at each end of every blade.

2.13 FIRE DAMPERS

A. Manufacturers: Subject to compliance with requirements, provide products by one of the following:

1. Pottorff; a division of PCI Industries, Inc.
 2. Ruskin Company.
- B. Type: Dynamic; rated and labeled according to UL 555 by an NRTL.
- C. Closing rating in ducts up to 4-inch wg (1-kPa) static pressure class and minimum 4000-fpm (20-m/s) velocity.
- D. Fire Rating: 1-1/2 and 3 hours.
- E. Frame: Curtain type with blades outside airstream ("Type B"); fabricated with roll-formed, 0.034-inch- (0.85-mm-) thick galvanized steel; with mitered and interlocking corners.
- F. Mounting Sleeve: Factory- or field-installed, galvanized sheet steel.
1. Minimum Thickness: 0.052 or 0.138 inch (1.3 or 3.5 mm) thick, as indicated, and of length to suit application.
 2. Exception: Omit sleeve where damper-frame width permits direct attachment of perimeter mounting angles on each side of wall or floor; thickness of damper frame must comply with sleeve requirements.
- G. Mounting Orientation: Vertical or horizontal as indicated.
- H. Blades: Roll-formed, interlocking, 0.034-inch- (0.85-mm-) thick, galvanized sheet steel. In place of interlocking blades, use full-length, 0.034-inch- (0.85-mm-) thick, galvanized-steel blade connectors.
- I. Horizontal Dampers: Include blade lock and stainless-steel closure spring.
- J. Heat-Responsive Device: Replaceable, 165 deg F (74 deg C) rated, fusible links.
- K. Provide fire dampers as noted on the plans and in ducts and openings in the following:
- a. Floors.
 - b. Fire walls.
 - c. Fire-resistance partitions.
 - d. Fire rated ceilings.
 - e. Exit corridor walls.
- L. Provide access door in duct adjacent to each fire damper.

2.14 SMOKE DAMPERS

- A. Manufacturers: Subject to compliance with requirements, provide products by one of the following:
1. Ruskin Company.
 2. Pottorff; a division of PCI Industries, Inc.
- B. General Requirements: Label according to UL 555S by an NRTL.
- C. Frame: Multiple blade type; fabricated with roll-formed, 0.034-inch- (0.85-mm-) thick galvanized steel; with mitered and interlocking corners.
- D. Blades: Airfoil type Roll-formed, horizontal, interlocking, 0.034-inch- (0.85-mm-) thick, galvanized sheet steel. In place of interlocking blades, use full-length, 0.034-inch- (0.85-mm-) thick, galvanized-steel blade connectors.
- E. Leakage: Class I.
- F. Rated pressure and velocity to exceed design airflow conditions.

- G. Mounting Sleeve: Factory-installed, 0.052-inch- (1.3-mm-) thick, galvanized sheet steel; length to suit wall or floor application with factory-furnished silicone caulking.
 - H. Provide motor mount bracket strengthener for dampers over 10" in height.
 - I. Provide a 10 gauge welded vertical stiffener at each corner to prevent damper misalignment.
 - J. Damper Motors: Two-position action, unless control sequence requires modulating. Coordinate with ATC contractor.
 - K. Actuators mounted out of the air stream, with automatic reset.
 - L. Comply with NEMA designation, temperature rating, service factor, enclosure type, and efficiency requirements for motors specified in Division 23 Section "Common Motor Requirements for HVAC Equipment."
 - 1. Motor Sizes: Minimum size as indicated. If not indicated, large enough so driven load will not require motor to operate in service factor range above 1.0.
 - 2. Controllers, Electrical Devices, and Wiring: Comply with requirements for electrical devices and connections specified in Division 23 Section "Instrumentation and Control for HVAC."
 - 3. Permanent-Split-Capacitor or Shaded-Pole Motors: With oil-immersed and sealed gear trains.
 - 4. Spring-Return Motors: Equip with an integral spiral-spring mechanism where indicated. Enclose entire spring mechanism in a removable housing designed for service or adjustments. Size for running torque rating of 150 in. x lbf (17 N x m) and breakaway torque rating of 150 in. x lbf (17 N x m).
 - 5. Outdoor Motors and Motors in Outdoor-Air Intakes: Equip with O-ring gaskets designed to make motors weatherproof. Equip motors with internal heaters to permit normal operation at minus 40 deg F (minus 40 deg C).
 - 6. Electrical Connection: 115 V, single phase, 60 Hz.
 - M. Accessories:
 - 1. Auxiliary switches for position indication.
 - 2. Test and reset switches, remotemounted.
 - N. The HVAC contractor shall provide all devices, relays, end switches, e/p switches, control components, air piping, power wiring, control wiring and interlock wiring as required to accomplish the sequence of operation for these dampers.
 - O. Provide access door in duct adjacent to each combination fire / smoke damper.
- 2.15 COMBINATION FIRE AND SMOKE DAMPERS
- A. Manufacturers: Subject to compliance with requirements, provide products by one of the following:
 - 1. Pottorff; a division of PCI Industries, Inc., model FSD-151, FSD-341, 1-1/2 or 3 hours rated as applicable
 - 2. Ruskin Company.model FSD-60, 1-1/2 or 3 hour rated as applicable
 - B. Type: Dynamic; rated and labeled according to UL 555 and UL 555S by an NRTL.
 - C. Closing rating in ducts up to 4-inch wg static pressure class and minimum 4000-fpm (20-m/s) velocity.
 - D. Fire Rating: 1-1/2 and 3 hours.

- E. Frame: multiblade type fabricated with roll-formed, 0.034-inch- (0.85-mm-) thick galvanized steel; with mitered and interlocking corners.
- F. Heat-Responsive Device: Replaceable, 165 deg F (74 deg C) rated, fusible links.
- G. Blades: 14 gauge galvanized airfoil shaped double skin, single piece construction, maximum 6 inches wide..
- H. Leakage: Class I.
- I. Rated pressure and velocity to exceed design airflow conditions.
- J. Mounting Sleeve: Factory-installed, 0.052-inch- (1.3-mm-) thick, galvanized sheet steel; length to suit wall or floor application with factory-furnished silicone caulking.
- K. Provide motor mount bracket strengthener for dampers over 10" in height.
- L. Provide a 10 gauge welded vertical stiffener at each corner to prevent damper misalignment
- M. Master control panel for use in dynamic smoke-management systems.
- N. Damper Motors: Two-position action unless control sequence requires modulating. Coordinate with ATC contractor.
- O. Actuators mounted out of the air stream,
- P. Comply with NEMA designation, temperature rating, service factor, enclosure type, and efficiency requirements for motors specified in Division 23 Section "Common Motor Requirements for HVAC Equipment."
 - 1. Motor Sizes: Minimum size as indicated. If not indicated, large enough so driven load will not require motor to operate in service factor range above 1.0.
 - 2. Controllers, Electrical Devices, and Wiring: Comply with requirements for electrical devices and connections specified in Division 23 Section "Instrumentation and Control for HVAC."
 - 3. Permanent-Split-Capacitor or Shaded-Pole Motors: With oil-immersed and sealed gear trains.
 - 4. Spring-Return Motors: Equip with an integral spiral-spring mechanism where indicated. Enclose entire spring mechanism in a removable housing designed for service or adjustments. Size for running torque rating of 150 in. x lbf (17 N x m) and breakaway torque rating of 150 in. x lbf (17 N x m).
 - 5. Outdoor Motors and Motors in Outdoor-Air Intakes: Equip with O-ring gaskets designed to make motors weatherproof. Equip motors with internal heaters to permit normal operation at minus 40 deg F (minus 40 deg C).
 - 6. Electrical Connection: 115 V, single phase, 60 Hz.
- Q. Accessories:
 - 1. Auxiliary switches for position indication.
 - 2. Test and reset switches, remote mounted.
- R. The HVAC contractor shall provide all devices, relays, end switches, e/p switches, control components, air piping, power wiring, control wiring and interlock wiring as required to accomplish the sequence of operation for these dampers.
- S. Provide combination fire / smoke dampers as noted on the plans.
- T. Provide access door in duct adjacent to each combination fire / smoke damper.

2.16 TURNING VANES

- A. Manufacturers: Subject to compliance with requirements, provide products by one of the following:
 - 1. Ductmate Industries, Inc.
 - 2. Duro Dyne Inc.
 - 3. METALAIRE, Inc.
 - 4. SEMCO Incorporated.
- B. Turning Vanes for Metal Ducts: Curved blades of galvanized sheet steel; support with bars perpendicular to blades set; set into vane runners suitable for duct mounting.
 - 1. Acoustic Turning Vanes: Fabricate airfoil-shaped aluminum extrusions with perforated faces and fibrous-glass fill.
- C. General Requirements: Comply with SMACNA's "HVAC Duct Construction Standards - Metal and Flexible"; "Vaness and Vane Runners," and "Vane Support in Elbows."
- D. Vane Construction: Double wall.
- E. The maximum unsupported vane length shall not exceed 48 inches.
- F. Single vane and short radius vanes are not acceptable.

2.17 REMOTE DAMPER OPERATORS

- A. Manufacturers: Subject to compliance with requirements, provide products by one of the following:
 - 1. Pottorff; a division of PCI Industries, Inc.
 - 2. Ventfabrics, Inc.
 - 3. Young Regulator Company.
- B. Description: Cable system designed for remote manual damper adjustment.
- C. Tubing: Brass.
- D. Cable: Stainless steel.
- E. Wall-Box Mounting: Recessed, 3/4 inches (19 mm) deep Surface.
- F. Wall-Box Cover-Plate Material: Steel.

2.18 DUCT-MOUNTED ACCESS DOORS

- A. Manufacturers: Subject to compliance with requirements, provide products by one of the following:
 - 1. Ductmate Industries, Inc.
 - 2. Greenheck Fan Corporation.
 - 3. McGill AirFlow LLC.
 - 4. Pottorff; a division of PCI Industries, Inc.
 - 5. Ventfabrics, Inc.
- B. Duct-Mounted Access Doors: Fabricate access panels according to SMACNA's "HVAC Duct Construction Standards - Metal and Flexible"; Figures 2-10, "Duct Access Doors and Panels," and 2-11, "Access Panels - Round Duct."
 - 1. Door:
 - a. Double wall, rectangular.

- b. Galvanized sheet metal with insulation fill and thickness as indicated for duct pressure class.
- c. Vision panel.
- d. Hinges and Latches: 1-by-1-inch (25-by-25-mm) butt or piano hinge and cam latches.
- e. Fabricate doors airtight and suitable for duct pressure class.
- 2. Frame: Galvanized sheet steel, with bend-over tabs and foam gaskets.
- 3. Number of Hinges and Locks:
 - a. Access Doors Less Than 12 Inches (300 mm) Square: No hinges and two sash locks.
 - b. Access Doors up to 18 Inches (460 mm) Square: Two hinges and two sash locks.
 - c. Access Doors up to 24 by 48 Inches (600 by 1200 mm): Three hinges and two compression latches with outside and inside handles.
 - d. Access Doors Larger Than 24 by 48 Inches (600 by 1200 mm): Four hinges and two compression latches with outside and inside handles.
- C. Furnish and install gasketed grease tight access doors on the grease hood exhaust duct as required under NFPA 96.

2.19 FLEXIBLE CONNECTORS

- A. Manufacturers: Subject to compliance with requirements, provide products by one of the following:
 - 1. Ductmate Industries, Inc.
 - 2. Duro Dyne Inc.
 - 3. Ventfabrics, Inc.
- B. Materials: Flame-retardant or noncombustible fabrics.
- C. Coatings and Adhesives: Comply with UL 181, Class 1.
- D. Metal-Edged Connectors: Factory fabricated with a fabric strip 3-1/2 inches (89 mm) wide attached to 2 strips of 2-3/4-inch- (70-mm-) wide, 0.028-inch- (0.7-mm-) thick, galvanized sheet steel or 0.032-inch- (0.8-mm-) thick aluminum sheets. Provide metal compatible with connected ducts.
- E. Indoor System, Flexible Connector Fabric: Glass fabric double coated with neoprene.
 - 1. Minimum Weight: 26 oz./sq. yd. (880 g/sq. m).
 - 2. Tensile Strength: 480 lbf/inch (84 N/mm) in the warp and 360 lbf/inch (63 N/mm) in the filling.
 - 3. Service Temperature: Minus 40 to plus 200 deg F (Minus 40 to plus 93 deg C).
- F. Outdoor System, Flexible Connector Fabric: Glass fabric double coated with weatherproof, synthetic rubber resistant to UV rays and ozone.
 - 1. Minimum Weight: 24 oz./sq. yd. (810 g/sq. m).
 - 2. Tensile Strength: 530 lbf/inch (93 N/mm) in the warp and 440 lbf/inch (77 N/mm) in the filling.
 - 3. Service Temperature: Minus 50 to plus 250 deg F (Minus 45 to plus 121 deg C).
- G. High-Temperature System, Flexible Connectors: Glass fabric coated with silicone rubber.
 - 1. Minimum Weight: 16 oz./sq. yd. (542 g/sq. m).

2. Tensile Strength: 285 lbf/inch (50 N/mm) in the warp and 185 lbf/inch (32 N/mm) in the filling.
 3. Service Temperature: Minus 67 to plus 500 deg F (Minus 55 to plus 260 deg C).
- H. High-Corrosive-Environment System, Flexible Connectors: Glass fabric with chemical-resistant coating.
1. Minimum Weight: 14 oz./sq. yd. (474 g/sq. m).
 2. Tensile Strength: 450 lbf/inch (79 N/mm) in the warp and 340 lbf/inch (60 N/mm) in the filling.
 3. Service Temperature: Minus 67 to plus 500 deg F (Minus 55 to plus 260 deg C).
- I. Thrust Limits: Combination coil spring and elastomeric insert with spring and insert in compression, and with a load stop. Include rod and angle-iron brackets for attaching to fan discharge and duct.
1. Frame: Steel, fabricated for connection to threaded rods and to allow for a maximum of 30 degrees of angular rod misalignment without binding or reducing isolation efficiency.
 2. Outdoor Spring Diameter: Not less than 80 percent of the compressed height of the spring at rated load.
 3. Minimum Additional Travel: 50 percent of the required deflection at rated load.
 4. Lateral Stiffness: More than 80 percent of rated vertical stiffness.
 5. Overload Capacity: Support 200 percent of rated load, fully compressed, without deformation or failure.
 6. Elastomeric Element: Molded, oil-resistant rubber or neoprene.
 7. Coil Spring: Factory set and field adjustable for a maximum of 1/4-inch (6-mm) movement at start and stop.
- 2.20 FLEXIBLE DUCTWORK
- A. Manufacturers: Subject to compliance with requirements, provide products by one of the following:
1. Buckley Associates
 2. Novaflex
- B. Construction
1. Flex duct shall comply with UL 181, Class 1.
 2. Flex duct shall be Type 4, with a heavy coated fiberglass cloth fabric liner, mechanically locked without adhesives. Helix shall be corrosive resistant galvanized steel formed and mechanically locked to fabric.
 3. For duct systems requiring insulation, the flex duct shall have 1 inch thick fiberglass insulation blanket encapsulated in a fire retardant polyethylene outer jacket with a flame spread less than 25 and smoke developed rating less than 50

PART 3 - EXECUTION

3.1 DUCT INSTALLATION

- A. Drawing plans, schematics, and diagrams indicate general location and arrangement of duct system. Indicated duct locations, configurations, and

arrangements were used to size ducts and calculate friction loss for air-handling equipment sizing and for other design considerations. Install duct systems as indicated unless deviations to layout are approved on Shop Drawings and Coordination Drawings.

- B. Install ducts according to SMACNA's "HVAC Duct Construction Standards - Metal and Flexible" unless otherwise indicated.
- C. Install round and flat-oval ducts in maximum practical lengths.
- D. Install ducts with fewest possible joints.
- E. Install factory- or shop-fabricated fittings for changes in direction, size, and shape and for branch connections.
- F. Unless otherwise indicated, install ducts vertically and horizontally, and parallel and perpendicular to building lines.
- G. Install ducts close to walls, overhead construction, columns, and other structural and permanent enclosure elements of building.
- H. Install ducts with a clearance of 1 inch (25 mm), plus allowance for insulation thickness.
- I. Route ducts to avoid passing through transformer vaults and electrical equipment rooms and enclosures.
- J. Where ducts pass through non-fire-rated interior partitions and exterior walls and are exposed to view, cover the opening between the partition and duct or duct insulation with sheet metal flanges of same metal thickness as the duct. Overlap openings on four sides by at least 1-1/2 inches (38 mm).
- K. Where ducts pass through fire-rated interior partitions and exterior walls, install fire dampers. Comply with requirements in Division 23 Section "Air Duct Accessories" for fire and smoke dampers.
- L. Protect duct interiors from moisture, construction debris and dust, and other foreign materials. Comply with SMACNA's "Duct Cleanliness for New Construction Guidelines."
- M. Flexible duct runouts to diffusers/registers/grilles shall not exceed six feet in length, fully extended.
- N. Install duct accessories of materials suited to duct materials; use galvanized-steel accessories in galvanized-steel and fibrous-glass ducts, stainless-steel accessories in stainless-steel ducts, and aluminum accessories in aluminum ducts.
- O. Install backdraft dampers at inlet of exhaust fans or exhaust ducts as close as possible to exhaust fan unless otherwise indicated.
- P. Install volume dampers at points on supply, return, and exhaust systems where branches extend from larger ducts. Where dampers are installed in ducts having duct liner, install dampers with hat channels of same depth as liner, and terminate liner with nosing at hat channel.
 - 1. Provide manual balancing volume dampers as required properly balance the air distribution system. If the location of balancing dampers are not defined on the drawings, the following minimum standards shall govern:
 - a. Low Pressure: All supply main air branches from trunk, each split, and all sub branches from main shall be provided with balancing dampers.

- b. Low Pressure: All exhaust main air branches from trunk, each split, and all sub branches from main shall be provided with balancing dampers.
 - c. Medium Pressure: All branches and takeoffs downstream of terminal boxes (CV, VAV and FPB) shall be provided with low leakage balancing dampers.
 - d. Ducts connecting to common plenums.
 - e. Ducts serving single outlet.
 - f. At open return duct in hung ceiling.
 - g. As noted on plans.
- 2. For internally lined ductwork: Provide 2 internal saddles to protect lining.
 - 3. Install levers to be accessible through the insulation
- Q. Set dampers to fully open position before testing, adjusting, and balancing.
- R. Install test holes at fan inlets and outlets and elsewhere as indicated.
- S. Install, combination fire & smoke fire and smoke dampers according to UL listing.
- T. Connect ducts to duct silencers rigidly.
- U. Install duct access doors on sides of ducts to allow for inspecting, adjusting, and maintaining accessories and equipment at the following locations:
- 1. On both sides of duct coils.
 - 2. Downstream from manual volume dampers, control dampers, turning vanes, and equipment.
 - 3. Adjacent to and close enough to fire or smoke dampers, to reset or reinstall fusible links. Access doors for access to fire or smoke dampers having fusible links shall be pressure relief access doors and shall be outward operation for access doors installed upstream from dampers and inward operation for access doors installed downstream from dampers.
 - 4. At each change in direction and at maximum 50-foot (15-m) spacing.
 - 5. Upstream of turning vanes.
 - 6. Elsewhere as indicated.
- V. Install access doors with swing against duct static pressure.
- W. Access Door Sizes:
- 1. One-Hand or Inspection Access: 8 by 5 inches.
 - 2. Two-Hand Access: 12 by 6 inches.
 - 3. Head and Hand Access: 18 by 10 inches.
 - 4. Head and Shoulders Access: 21 by 14 inches.
 - 5. Body Access: 25 by 14 inches.
 - 6. Body plus Ladder Access: 25 by 17 inches.
- X. Label access doors according to Division 23 Section "Identification for HVAC Piping and Equipment" to indicate the purpose of access door.
- Y. Install flexible connectors to connect ducts to equipment.
- Z. For fans developing static pressures of 5-inch wg and more, cover flexible connectors with loaded vinyl sheet held in place with metal straps.
- AA. Connect terminal units to supply ducts directly. Do not use flexible ducts provide flexible connections for all fan powered terminal boxes.
- BB. Connect diffusers to flexible ducts with draw bands.
- CC. Install duct test holes where required for testing and balancing purposes.

- DD. Install thrust limits at centerline of thrust, symmetrical on both sides of equipment. Attach thrust limits at centerline of thrust and adjust to a maximum of 1/4-inch (6-mm) movement during start and stop of fans.

3.2 SEAM AND JOINT SEALING

- A. Seal duct seams and joints for duct static-pressure and leakage classes specified in "Performance Requirements" Article, according to SMACNA's "HVAC Duct Construction Standards - Metal and Flexible," Standard Duct Sealing Requirements," unless otherwise indicated..

3.3 HANGER AND SUPPORT INSTALLATION

- A. Comply with SMACNA's "HVAC Duct Construction Standards - Metal and Flexible," "Hangers and Supports."
- B. Building Attachments: Concrete inserts, powder-actuated fasteners, or structural-steel fasteners appropriate for construction materials to which hangers are being attached.
 - 1. Where practical, install concrete inserts before placing concrete.
 - 2. Install powder-actuated concrete fasteners after concrete is placed and completely cured.
 - 3. Use powder-actuated concrete fasteners for standard-weight aggregate concretes or for slabs more than 4 inches (100 mm) thick.
 - 4. Do not use powder-actuated concrete fasteners for lightweight-aggregate concretes or for slabs less than 4 inches (100 mm) thick.
 - 5. Do not use powder-actuated concrete fasteners for seismic restraints.
- C. Hanger Spacing: Comply with the requirements of this section, the BUILDING CODE and SMACNA's "HVAC Duct Construction Standards - Metal and Flexible," "Rectangular Duct Hangers Minimum Size," and "Minimum Hanger Sizes for Round Duct," for maximum hanger spacing whichever is more stringent. Install hangers and supports within 24 inches (610 mm) of each elbow and within 48 inches (1200 mm) of each branch intersection.
- D. Hangers Exposed to View: Threaded rod and angle or channel supports.
- E. Support vertical ducts with steel angles or channel secured to the sides of the duct with welds, bolts, sheet metal screws, or blind rivets; support at each floor and at a maximum intervals of 16 feet.
- F. Install upper attachments to structures. Select and size upper attachments with pull-out, tension, and shear capacities appropriate for supported loads and building materials where used.
- G. Hangers, horizontal ducts:
 - 1. To 2 sq ft in area: Provide galvanized steel strap hangers, minimum 1 inch x 1/8 inch, maximum 8 ft - 0 inch spacing.
 - 2. 2 to 4 sq ft in area: Galvanized steel strap hangers, minimum 1 inch x 1/8 inch, maximum 8 ft 0 inch spacing.
 - 3. Strap hangers shall be bent 2 inch under the bottom corner of rectangular ducts. One screw shall secure 2 inch portion of hanger to bottom of duct. Straps shall be secured to side of duct with a minimum of two screws and more, as necessary, to provide a maximum screw spacing of 12 inch. Side-

- of-duct screws shall be located not more than 2 inch from top and bottom of duct.
4. 4 to 10 sq ft in area: Provide galvanized steel trapeze angles from steel threaded rods with a maximum 6 ft - 0 inch spacing.
 5. Over 10 sq ft in area: Provide galvanized steel trapeze angles from steel threaded rods with a maximum 4 ft - 0 inch spacing.
 6. Provide stronger support to match larger and heavier ducts; provide cross-bracing, angle iron hangers, as required for rigid and adequate supports.
 7. In mechanical rooms: Provide black steel painted or galvanized, vertical angles or rods and horizontal angles across ductwork.
 8. Kitchen exhaust in accordance with NFPA 96.
- H. Hangers Vertical ducts: At each floor, provide minimum 2 supports per duct fastened to duct and spanning shaft opening. Fasten supports to floor or structural construction. Maximum screw spacing shall be 12 inch on center and maximum shall be four screw per riser.
1. Angles and channels: Provide painted black steel or galvanized. Where angles are specified, channels of equivalent strength, material and protective coating will be permitted. Where more than one duct is supported by a common set of angles, support size shall be determined by sum of width dimensions.
 2. Supports: Provide as follows, except increase supports as required for load and span where span of angles exceed 6 ft or floor-to-floor height exceeds 14 ft.
 - a. Duct width to 30 inch: Provide angle size: 1-1/4 inch x 1-1/4 inch x 1/8 inch.
 - b. Duct width, 31 inch to 54 inch: Angle size shall be 2 inch x 2 inch x 3/16 inch.
 - c. Duct width, 55 inch to 90 inch: Angle size shall be 2 inch x 2 inch x 1/4 inch.
 3. Vertical kitchen exhaust, fireproofed and plastered ducts: Provide minimum 3 inch, 4.1 lb/ft, steel channels fastened to slab, welded to building structural steel or as acceptable. Supports shall be bolted or welded to ducts and in accordance with NFPA 96.

3.4 SEISMIC-RESTRAINT-DEVICE INSTALLATION

- A. Install ducts with hangers and braces designed to support the duct and to restrain against seismic forces required by applicable building codes. Comply with SMACNA's "Seismic Restraint Manual: Guidelines for Mechanical Systems." SEI/ASCE 7.
 1. Space lateral supports a maximum of 40 feet (12 m) o.c., and longitudinal supports a maximum of 80 feet (24 m) o.c.
 2. Brace a change of direction longer than 12 feet (3.7 m).
- B. Select seismic-restraint devices with capacities adequate to carry present and future static and seismic loads.
- C. Install cables so they do not bend across edges of adjacent equipment or building structure.
- D. Install cable restraints on ducts that are suspended with vibration isolators.
- E. Install seismic-restraint devices using methods approved by an evaluation service member of the ICC Evaluation Service.

- F. Attachment to Structure: If specific attachment is not indicated, anchor bracing and restraints to structure, to flanges of beams, to upper truss chords of bar joists, or to concrete members.
- G. Drilling for and Setting Anchors:
 - 1. Identify position of reinforcing steel and other embedded items prior to drilling holes for anchors. Do not damage existing reinforcement or embedded items during drilling. Notify the Architect if reinforcing steel or other embedded items are encountered during drilling. Locate and avoid prestressed tendons, electrical and telecommunications conduit, and gas lines.
 - 2. Do not drill holes in concrete or masonry until concrete, mortar, or grout has achieved full design strength.
 - 3. Wedge Anchors: Protect threads from damage during anchor installation. Heavy-duty sleeve anchors shall be installed with sleeve fully engaged in the structural element to which anchor is to be fastened.
 - 4. Set anchors to manufacturer's recommended torque, using a torque wrench.
 - 5. Install zinc-coated steel anchors for interior applications and stainless-steel anchors for applications exposed to weather.

3.5 CONNECTIONS

- A. Make connections to equipment with flexible connectors.
- B. Comply with SMACNA's "HVAC Duct Construction Standards - Metal and Flexible" for branch, outlet and inlet, and terminal unit connections.

3.6 PAINTING

- A. Paint interior of metal ducts that are visible through registers and grilles and that do not have duct liner. Apply one coat of flat, black, latex paint over a compatible galvanized-steel primer. Paint materials and application requirements are specified in Division 09 painting Sections.

3.7 FIELD QUALITY CONTROL

- A. Perform tests and inspections.
- B. Leakage Tests:
 - 1. Comply with SMACNA's "HVAC Air Duct Leakage Test Manual."
 - 2. All testing shall be done in the presence of the engineer or owner's representative. The contractor is responsible for providing all collars, caps, electric power, etc. necessary to perform the tests. The contractor is also responsible for scheduling the test no less than three (3) business days prior to its intended occurrence. Low pressure ductwork (2" class) shall be tested on an as needed basis at the engineer's direction. Leakage test procedure shall follow the outlines and classifications in the SMACNA HVAC duct leakage test manual. If specimen fails to meet allotted leakage level, the contractor shall modify to bring it into compliance and shall retest it until acceptable leakage is demonstrated. Tests and necessary repair shall be completed prior to concealment of ducts.

3. Test the following systems:
 - a. All ductwork greater than 2" class as defined within is to be tested. .
 4. Disassemble, reassemble, and seal segments of systems to accommodate leakage testing and for compliance with test requirements.
 5. Test for leaks before insulation application.
 6. Conduct tests at static pressures equal to maximum design pressure of system or section being tested. If static-pressure classes are not indicated, test entire system at maximum system design pressure. Do not pressurize systems above maximum design operating pressure. Give seven days' advance notice for testing.
- C. Duct System Cleanliness Tests:
1. Visually inspect duct system to ensure that no visible contaminants are present.
 2. Test sections of metal duct system, chosen randomly by Owner, for cleanliness according to "Vacuum Test" in NADCA ACR, "Assessment, Cleaning and Restoration of HVAC Systems."
 - a. Acceptable Cleanliness Level: Net weight of debris collected on the filter media shall not exceed 0.75 mg/100 sq. cm.
- D. Duct system will be considered defective if it does not pass tests and inspections.
- E. Prepare test and inspection reports.

3.8 DUCT CLEANING

- A. Clean new duct system(s) before testing, adjusting, and balancing.
- B. Use service openings for entry and inspection.
1. Create new openings and install access panels appropriate for duct static-pressure class if required for cleaning access. Provide insulated panels for insulated or lined duct. Patch insulation and liner as recommended by duct liner manufacturer.
 2. Disconnect and reconnect flexible ducts as needed for cleaning and inspection.
 3. Remove and reinstall ceiling to gain access during the cleaning process.
- C. Particulate Collection and Odor Control:
1. When venting vacuuming system inside the building, use HEPA filtration with 99.97 percent collection efficiency for 0.3-micron-size (or larger) particles.
 2. When venting vacuuming system to outdoors, use filter to collect debris removed from HVAC system, and locate exhaust downwind and away from air intakes and other points of entry into building.
- D. Clean the following components by removing surface contaminants and deposits:
1. Air outlets and inlets (registers, grilles, and diffusers).
 2. Supply, return, and exhaust fans including fan housings, plenums (except ceiling supply and return plenums), scrolls, blades or vanes, shafts, baffles, dampers, and drive assemblies.
 3. Air-handling unit internal surfaces and components including mixing box, coil section, condensate drain pans, humidifiers, filters and filter sections, and condensate collectors and drains.
 4. Coils and related components.
 5. Return-air ducts, dampers, actuators, and turning vanes except in ceiling plenums and mechanical equipment rooms.

6. Supply-air ducts, dampers, actuators, and turning vanes.
 7. Dedicated exhaust and ventilation components and makeup air systems.
- E. Mechanical Cleaning Methodology:
1. Clean metal duct systems using mechanical cleaning methods that extract contaminants from within duct systems and remove contaminants from building.
 2. Use vacuum-collection devices that are operated continuously during cleaning. Connect vacuum device to downstream end of duct sections so areas being cleaned are under negative pressure.
 3. Use mechanical agitation to dislodge debris adhered to interior duct surfaces without damaging integrity of metal ducts, duct liner, or duct accessories.
 4. Clean fibrous-glass duct liner with HEPA vacuuming equipment; do not permit duct liner to get wet. Replace fibrous-glass duct liner that is damaged, deteriorated, or delaminated or that has friable material, mold, or fungus growth.
 5. Clean coils and coil drain pans according to NADCA 1992. Keep drain pan operational. Rinse coils with clean water to remove latent residues and cleaning materials; comb and straighten fins.
 6. Provide drainage and cleanup for wash-down procedures.
 7. Antimicrobial Agents and Coatings: Apply EPA-registered antimicrobial agents if fungus is present. Apply antimicrobial agents according to manufacturer's written instructions after removal of surface deposits and debris.

3.9 DUCT SCHEDULE

- A. Fabricate ducts with galvanized sheet steel except as follows:
- B. Exposed ductwork:
1. Where ductwork is indicated to be exposed to view in occupied spaces, provide materials which are free from visual imperfections, including pittings, seam marks, stains, discolorations, and other imperfections. Provide finishes which will allow painting. Provide flat type seams and joints for all exposed duct construction
 2. Watertight Ductwork exposed to weather, except as noted shall be as follows:
 - a. Aluminum.
 - b. Watertight.
 3. Outside air, exhaust and relief duct shall be as follows:
 - a. Aluminum.
 - b. Watertight.
 - c. Extent:
 - 1) Within 10 ft. of louvers.
 4. Ductwork at duct humidifiers shall be as follows:
 - a. Aluminum.
 - b. Watertight.
 - c. Minimum 2 ft. upstream.
 - d. Minimum 10 ft downstream.
 5. Sub sterile exhaust ductwork, provide as follows:
 - a. 316 Stainless Steel.
 - b. Welded.
 - c. Construction shall be in accordance with SMACNA rectangular industrial duct construction standards.
 6. Canopy fume hoods shall be as follows:

- a. ACGIH Industrial Ventilation Manual, unless noted otherwise.
 - b. Stainless steel No. 16 USSG.
 - c. Internal angles and seams.
 - d. Bolts shall be countersunk.
 - e. Size, configuration and support shall be as indicated.
- C. Liner:
1. Comply with requirements specified in Division 23 Section 'NOISE CONTROL'.
- D. Double-Wall Duct Interstitial Insulation / acoustic lining:
1. Supply- and Return-Air Ducts, 1 inch thick.
- E. Elbow Configuration:
1. Rectangular Duct: Comply with SMACNA's "HVAC Duct Construction Standards - Metal and Flexible," Rectangular Elbows."
 - 1) Radius Type RE 1 with minimum 1.5 radius-to-diameter ratio.
 - 2) Mitered Type RE 2 with vanes complying with SMACNA's "HVAC Duct Construction Standards - Metal and Flexible," Vanes and Vane Runners," and "Vane Support in Elbows."
 - 3) Provide splitter vanes on all short radius elbows.
 - 4) Provide double thickness turning vanes on all square elbows.
 2. Round Duct: Comply with SMACNA's "HVAC Duct Construction Standards - Metal and Flexible," "Round Duct Elbows."
 - a. Minimum Radius-to-Diameter Ratio and Elbow Segments: Comply with SMACNA's "HVAC Duct Construction Standards - Metal and Flexible," Mitered Elbows." Elbows with less than 90-degree change of direction have proportionately fewer segments, conform to SMACNA.
 - 1) Velocity 1000 fpm or Lower: 0.6 radius-to-diameter ratio and three segments for 90-degree elbow.
 - 2) Velocity 1000 to 1500 fpm: 1.0 radius-to-diameter ratio and four segments for 90-degree elbow.
 - 3) Velocity 1500 fpm or Higher: 1.5 radius-to-diameter ratio and five segments for 90-degree elbow.
 - b. Round Elbows, 12 Inches and Smaller in Diameter: Stamped or pleated.
 - c. Round Elbows, 14 Inches and Larger in Diameter: Welded.
- F. Branch Configuration:
1. Rectangular Duct: Comply with SMACNA's "HVAC Duct Construction Standards - Metal and Flexible," "Branch Connections."
 - a. Rectangular Main to Rectangular Branch: 45-degree entry.
 - b. Rectangular Main to Round Branch: flanged spin in, conical.
 - c. Do not use "butt flange" straight taps.
 - d. Divided flow branches
 - 1) Provide long radius takeoff or square elbow as per SMACNA.
 2. Round and Flat Oval: Comply with SMACNA's "HVAC Duct Construction Standards - Metal and Flexible," "90 Degree Tees and Laterals," and "Conical Tees."
 - a. Velocity 1000 fpm or Lower: 90-degree tee fitting.
 - b. Velocity 1000 to 1500 fpm: Conical fitting.
 - c. Velocity 1500 fpm or Higher: 45-degree lateral fitting.
 - d. Saddle taps are NOT permitted.
 - e. No bull head tees

- f. Divided flow branches, conical tees, y- branch or reducing Y-branch.or Tee's
- G. Obstructions
 - 1. Conform to SMACNA
- H. Offsets and transitions
 - 1. Conform to SMACNA

END OF SECTION

This page is intentionally left blank.

SECTION 23 33 00

AIR DUCT ACCESSORIES

PART 1 - GENERAL

1.1 RELATED DOCUMENTS

- A. Drawings and general provisions of the Contract, including General and Supplementary Conditions and Division 01 Specification Sections, apply to this Section.
- B. Section 01 81 13 "Sustainable Design Requirements – LEED v4 for Building Design & Construction – New Construction" for sustainable design requirements and detailed sustainable design submittal requirements.
- C. Section 01 74 19 "Construction and Demolition Waste Management and Disposal" for disposal of construction, demolition and packaging waste disposal requirements.

1.2 SUMMARY

- A. Section Includes:
 - 1. Backdraft and pressure relief dampers.
 - 2. Barometric relief dampers.
 - 3. Manual volume dampers.
 - 4. Control dampers.
 - 5. Fire dampers.
 - 6. Ceiling dampers.
 - 7. Smoke dampers.
 - 8. Combination fire and smoke dampers.
 - 9. Corridor dampers.
 - 10. Flange connectors.
 - 11. Turning vanes.
 - 12. Remote damper operators.
 - 13. Duct-mounted access doors.
 - 14. Flexible connectors.
 - 15. Duct security bars.
 - 16. Duct accessory hardware.
- B. Sustainable Building Requirements:
 - 1. The Owner requires the Contractor to implement practices and procedures to meet the project's environmental performance goals, which include achieving LEED version 4 **Certified** level Certification. Specific project goals that may impact this area of work include: use of recycled-content materials; use of locally-manufactured materials; use of low-emitting materials; construction waste recycling; and the implementation of a construction indoor air quality management plan. The Contractor shall ensure that the requirements related to these goals, as defined in the Articles below, are implemented to the fullest extent. Substitutions, or other changes to the work proposed by the

Contractor or their Subcontractors, shall not be allowed if such changes compromise the aforementioned environmental goals and LEED certification.

1.3 Related Sections:

- A. Division 23 Section "HVAC Gravity Ventilators" for roof-mounted ventilator caps.
- B. Division 28 Section "Fire Detection and Alarm" for duct-mounted fire and smoke detectors.
- C. Section 01 81 13 "Sustainable Design Requirements – LEED v4 for Building Design & Construction – New Construction" for sustainable design requirements and detailed sustainable design submittal requirements.
- D. Section 01 74 19 "Construction and Demolition Waste Management and Disposal" for disposal of construction, demolition and packaging waste disposal requirements.
- E.

1.4 SUBMITTALS

- A. Product Data: For each type of product indicated.
 - 1. For duct silencers, include pressure drop and dynamic insertion loss data. Include breakout noise calculations for high transmission loss casings.
- B. Shop Drawings: For duct accessories. Include plans, elevations, sections, details and attachments to other work.
 - 1. Detail duct accessories fabrication and installation in ducts and other construction. Include dimensions, weights, loads, and required clearances; and method of field assembly into duct systems and other construction. Include the following:
 - a. Special fittings.
 - b. Manual volume damper installations.
 - c. Control damper installations.
 - d. Fire-damper, smoke-damper, combination fire- and smoke-damper, ceiling, and corridor damper installations, including sleeves; and duct-mounted access doors and remote damper operators.
 - e. Duct security bars.
 - f. Wiring Diagrams: For power, signal, and control wiring.
- C. Coordination Drawings: Reflected ceiling plans, drawn to scale, on which ceiling-mounted access panels and access doors required for access to duct accessories are shown and coordinated with each other, using input from Installers of the items involved.
- D. Source quality-control reports.
- E. Operation and Maintenance Data: For air duct accessories to include in operation and maintenance manuals.

1.5 QUALITY ASSURANCE

- A. Comply with NFPA 90A, "Installation of Air Conditioning and Ventilating Systems," and with NFPA 90B, "Installation of Warm Air Heating and Air Conditioning Systems."

- B. Comply with AMCA 500-D testing for damper rating.

1.6 EXTRA MATERIALS

- A. Furnish extra materials that match products installed and that are packaged with protective covering for storage and identified with labels describing contents.
 - 1. Fusible Links: Furnish quantity equal to 10 percent of amount installed.

PART 2 - PRODUCTS

2.1 MATERIALS

- A. Comply with SMACNA's "HVAC Duct Construction Standards - Metal and Flexible" for acceptable materials, material thicknesses, and duct construction methods unless otherwise indicated. Sheet metal materials shall be free of pitting, seam marks, roller marks, stains, discolorations, and other imperfections.
- B. Galvanized Sheet Steel: Comply with ASTM A 653/A 653M.
 - 1. Galvanized Coating Designation: **G60 (Z180)**.
 - 2. Exposed-Surface Finish: Mill phosphatized.
- C. Stainless-Steel Sheets: Comply with ASTM A 480/A 480M, Type 304, and having a No. 2D finish for concealed ducts and No 4 finish for exposed ducts.
- D. Aluminum Sheets: Comply with **ASTM B 209 (ASTM B 209M)**, Alloy 3003, Temper H14; with mill finish for concealed ducts and standard, 1-side bright finish for exposed ducts.
- E. Extruded Aluminum: Comply with **ASTM B 221 (ASTM B 221M)**, Alloy 6063, Temper T6.
- F. Reinforcement Shapes and Plates: Galvanized-steel reinforcement where installed on galvanized sheet metal ducts; compatible materials for aluminum and stainless-steel ducts.
- G. Tie Rods: Galvanized steel, **1/4-inch (6-mm)** minimum diameter for lengths **36 inches (900 mm)** or less; **3/8-inch (10-mm)** minimum diameter for lengths longer than **36 inches (900 mm)**.

2.2 BACKDRAFT AND PRESSURE RELIEF DAMPERS

- A. Manufacturers: Subject to compliance with requirements, provide products by one of the following:
 - 1. Greenheck Fan Corporation.
 - 2. Pottorff; a division of PCI Industries, Inc.
 - 3. Ruskin Company.
- B. Description: Gravity balanced.
- C. Maximum Air Velocity: **2000 fpm (10 m/s)**
- D. Maximum System Pressure: **2-inch wg (0.5 kPa)**
- E. Frame: **0.052-inch- (1.3-mm-)** thick, galvanized sheet steel with welded corners and mounting flange.

- F. Blades: Multiple single-piece blades, center-pivoted, maximum **6-inch (150-mm)** width, **0.050-inch- (1.2-mm-)** thick aluminum sheet noncombustible, tear-resistant, neoprene-coated fiberglass with sealed edges.
- G. Blade Action: Parallel.
- H. Blade Seals: Neoprene, mechanically locked.
- I. Blade Axles:
 - 1. Material: Stainless steel
 - 2. Diameter: **0.20 inch (5 mm)**
- J. Tie Bars and Brackets: Aluminum
- K. Return Spring: Adjustable tension.
- L. Bearings: Synthetic pivot bushings.
- M. Accessories:
 - 1. Adjustment device to permit setting for varying differential static pressure.
 - 2. Counterweights and spring-assist kits for vertical airflow installations.
 - 3. Electric actuators.
 - 4. Chain pulls.
 - 5. Front of rear screens.
 - 6. 90-degree stops.
- N. Sleeve: Minimum **16-gage** thickness.

2.3 BAROMETRIC RELIEF DAMPERS

- A. Manufacturers: Subject to compliance with requirements, provide products by one of the following:
 - 1. Greenheck Fan Corporation.
 - 2. Pottorff; a division of PCI Industries, Inc.
 - 3. Ruskin Company.
- B. Suitable for horizontal or vertical mounting.
- C. Maximum Air Velocity: **2000 fpm (10 m/s)**
- D. Maximum System Pressure: **2-inch wg (0.5 kPa)**
- E. Frame: **0.064-inch- (1.6-mm-)** thick, galvanized sheet steel with welded corners and mounting flange.
- F. Blades:
 - 1. Multiple, **0.050-inch- (1.2-mm-)** thick aluminum sheet.
 - 2. Maximum Width: **6 inches (150 mm)**.
 - 3. Action: Parallel.
 - 4. Balance: Gravity.
 - 5. Eccentrically pivoted.
- G. Blade Seals: Neoprene.
- H. Blade Axles: Nonferrous metal.
- I. Tie Bars and Brackets:
 - 1. Material: Aluminum
 - 2. Rattle free with 90-degree stop.
- J. Return Spring: Adjustable tension.

- K. Bearings: Synthetic
- L. Accessories:
 - 1. Flange on intake.
 - 2. Adjustment device to permit setting for varying differential static pressures.

2.4 MANUAL VOLUME DAMPERS

- A. Dampers to be the same as duct construction.
- B. Standard, Steel, Manual Volume Dampers:
 - 1. Manufacturers: Subject to compliance with requirements, provide products by one of the following:
 - a. Pottorff; a division of PCI Industries, Inc.
 - b. Ruskin Company.
 - 2. Standard leakage rating, with linkage outside airstream.
 - 3. Suitable for horizontal or vertical applications.
 - 4. Frames:
 - a. Hat-shaped, galvanized -steel channels, 0.064-inch (1.62-mm) minimum thickness.
 - b. Mitered and welded corners.
 - c. Flanges for attaching to walls and flangeless frames for installing in ducts.
 - 5. Blades:
 - a. Multiple or single blade.
 - b. Provide single blade dampers up to 6 inch width and opposed multiblade dampers above 6 inches in width.
 - c. Parallel- or opposed-blade design.
 - d. Stiffen damper blades for stability.
 - e. Galvanized -steel, 0.064 inch (1.62 mm) thick (16 ga.).
 - 6. Blade Axles: Galvanized steel.
 - 7. Bearings:
 - a. Molded synthetic.
 - b. Dampers in ducts with pressure classes of 3-inch wg (750 Pa) or less shall have axles full length of damper blades and bearings at both ends of operating shaft.
 - 8. Tie Bars and Brackets: Galvanized steel.
- C. Standard, Aluminum, Manual Volume Dampers:
 - 1. Manufacturers: Subject to compliance with requirements, provide products by one of the following:
 - a. Pottorff; a division of PCI Industries, Inc.
 - b. Ruskin Company.
 - 2. Standard leakage rating, with linkage outside airstream.
 - 3. Suitable for horizontal or vertical applications.
 - 4. Frames: Hat-shaped, 0.10-inch- (2.5-mm-) thick, aluminum sheet channels; frames with flanges for attaching to walls and flangeless frames for installing in ducts.
 - 5. Blades:
 - a. Multiple or single blade.
 - b. Parallel- or opposed-blade design.
 - c. Stiffen damper blades for stability.
 - d. Extruded-Aluminum Blades: 0.050-inch- (1.2-mm-) thick extruded aluminum.

6. Blade Axles: Nonferrous metal.
 7. Bearings:
 - a. Molded synthetic.
 - b. Dampers in ducts with pressure classes of 3-inch wg (750 Pa) or less shall have axles full length of damper blades and bearings at both ends of operating shaft.
 8. Tie Bars and Brackets: Aluminum.
- D. Low-Leakage, Steel, Manual Volume Dampers:
1. Manufacturers: Subject to compliance with requirements, provide products by one of the following:
 - a. Pottorff; a division of PCI Industries, Inc.
 - b. Ruskin Company.
 2. Low-leakage rating, with linkage outside airstream, and bearing AMCA's Certified Ratings Seal for both air performance and air leakage.
 3. Suitable for horizontal or vertical applications.
 4. Frames:
 - a. Hat shaped.
 - b. Galvanized -steel channels, 0.064 inch (1.62 mm) thick.
 - c. Mitered and welded corners.
 - d. Flanges for attaching to walls and flangeless frames for installing in ducts.
 5. Blades:
 - a. Multiple or single blade.
 - b. Parallel- or opposed-blade design.
 - c. Stiffen damper blades for stability.
 - d. Galvanized, roll-formed steel, 0.064 inch (1.62 mm) thick. (16 ga.).
 6. Blade Axles: Nonferrous metal.
 7. Bearings:
 - a. Molded synthetic.
 - b. Dampers in ducts with pressure classes of 3-inch wg (750 Pa) or less shall have axles full length of damper blades and bearings at both ends of operating shaft.
 8. Blade Seals: Neoprene.
 9. Jamb Seals: Cambered aluminum.
 10. Tie Bars and Brackets: Galvanized steel.
 11. Accessories:
 - a. Include locking device to hold single-blade dampers in a fixed position without vibration.
- E. Low-Leakage, Aluminum, Manual Volume Dampers:
1. Manufacturers: Subject to compliance with requirements, provide products by one of the following:
 - a. Ruskin Company.
 - b. Trox USA Inc.
 2. Low-leakage rating, with linkage outside airstream, and bearing AMCA's Certified Ratings Seal for both air performance and air leakage.
 3. Suitable for horizontal or vertical applications.
 4. Frames: Hat -shaped, 0.10-inch- (2.5-mm-) thick, aluminum sheet channels; frames with flanges for attaching to walls and flangeless frames for installing in ducts.
 5. Blades:
 - a. Multiple or single blade.

- b. Parallel- or opposed-blade design.
 - c. Extruded-Aluminum Blades: **0.050-inch- (1.2-mm-)** thick extruded aluminum.
 - 6. Blade Axles: Stainless steel.
 - 7. Bearings:
 - Molded synthetic.
 - a. Dampers in ducts with pressure classes of **3-inch wg (750 Pa)** or less shall have axles full length of damper blades and bearings at both ends of operating shaft.
 - 8. Blade Seals: Neoprene.
 - 9. Jamb Seals: Cambered aluminum.
 - 10. Tie Bars and Brackets: Aluminum.
 - 11. Accessories:
 - a. Include locking device to hold single-blade dampers in a fixed position without vibration.
 - F. Jackshaft:
 - 1. Size: **1-inch (25-mm)** diameter.
 - 2. Material: Galvanized-steel pipe rotating within pipe-bearing assembly mounted on supports at each mullion and at each end of multiple-damper assemblies.
 - 3. Length and Number of Mountings: As required to connect linkage of each damper in multiple-damper assembly.
 - G. Damper Hardware:
 - 1. Zinc-plated, die-cast core with dial and handle made of **3/32-inch- (2.4-mm-)** thick zinc-plated steel, and a **3/4-inch (19-mm)** hexagon locking nut.
 - 2. Include center hole to suit damper operating-rod size.
 - 3. Include elevated platform for insulated duct mounting.
- 2.5 CONTROL DAMPERS
- A. Manufacturers: Subject to compliance with requirements, provide products by one of the following:
 - 1. Greenheck Fan Corporation.
 - 2. Ruskin Company.
 - B. Low-leakage rating, with linkage outside airstream, and bearing AMCA's Certified Ratings Seal for both air performance and air leakage.
 - C. Dampers to be the same as duct construction.
 - D. For internally lined ductwork: Provide 2 internal saddles to protect lining.
 - E. Frames:
 - 1. Hat shaped.
 - 2. Galvanized -steel channels, **0.064 inch (1.62 mm)** thick.
 - 3. Mitered and welded corners.
 - F. Blades:
 - 1. Provide airfoil blades.
 - 2. Multiple blade with maximum blade width of **8 inches (200 mm)**.
 - 3. Provide dampers with parallel blades for 2 position control and opposed blades for modulating control.
 - 4. Parallel- and opposed blade design.
 - 5. Galvanized steel.

6. **0.064 inch (1.62 mm)** thick.
 7. Blade Edging: Closed-cell neoprene edging.
- G. Blade Axles: **1/2-inch- (13-mm-)** diameter; nonferrous metal; blade-linkage hardware of zinc-plated steel and brass; ends sealed against blade bearings.
1. Operating Temperature Range: From **minus 40 to plus 200 deg F (minus 40 to plus 93 deg C)**.
- H. Bearings:
1. Molded synthetic.
 2. Dampers in ducts with pressure classes of **3-inch wg (750 Pa)** or less shall have axles full length of damper blades and bearings at both ends of operating shaft.
 3. Thrust bearings at each end of every blade.

2.6 FIRE DAMPERS

- A. Manufacturers: Subject to compliance with requirements, provide products by one of the following:
1. Pottorff; a division of PCI Industries, Inc.
 2. Ruskin Company.
- B. Type: Dynamic; rated and labeled according to UL 555 by an NRTL.
- C. Closing rating in ducts up to **4-inch wg (1-kPa)** static pressure class and minimum **4000-fpm (20-m/s)** velocity.
- D. Dampers shall contain a NYC MEA# and be approved for use in NYC.
- E. Fire Rating: 1-1/2 hours.
- F. Frame: Curtain type with blades outside airstream ("Type B"); fabricated with roll-formed, **0.034-inch- (0.85-mm-)** thick galvanized steel; with mitered and interlocking corners.
- G. Mounting Sleeve: Factory- or field-installed, galvanized sheet steel.
1. Minimum Thickness: **0.052 or 0.138 inch (1.3 or 3.5 mm)** thick, as indicated, and of length to suit application.
 2. Exception: Omit sleeve where damper-frame width permits direct attachment of perimeter mounting angles on each side of wall or floor; thickness of damper frame must comply with sleeve requirements.
- H. Mounting Orientation: Vertical or horizontal as indicated.
- I. Blades: Roll-formed, interlocking, **0.034-inch- (0.85-mm-)** thick, galvanized sheet steel. In place of interlocking blades, use full-length, **0.034-inch- (0.85-mm-)** thick, galvanized-steel blade connectors.
- J. Horizontal Dampers: Include blade lock and stainless-steel closure spring.
- K. Heat-Responsive Device: Replaceable, **165 deg F (74 deg C)** rated, fusible links.
- L. Heat-Responsive Device: Electric resettable link and switch package, factory installed, **165 deg F (74 deg C)** rated.
- M. The HVAC contractor shall provide all devices, relays, end switches, e/p switches, control components, air piping, power wiring, control wiring and interlock wiring as required to accomplish the sequence of operation for these dampers.

- N. Provide fire dampers as noted on the plans and in ducts and openings in the following:
 - 1. Shafts.
 - 2. Floors.
 - 3. Fire walls.
 - 4. Fire-resistance partitions.
 - 5. Fire rated ceilings.
 - 6. Exit corridor walls.
- O. Provide access door in duct adjacent to each fire damper.

2.7 CEILING DAMPERS

- A. Manufacturers: Subject to compliance with requirements, provide products by one of the following:
 - 1. Ruskin Company.
 - 2. Pottorff; a division of PCI Industries, Inc.
- B. General Requirements:
 - 1. Labeled according to UL 555C by an NRTL.
 - 2. Comply with construction details for tested floor- and roof-ceiling assemblies as indicated in UL's "Fire Resistance Directory."
- C. Frame: Galvanized sheet steel, round or rectangular, style to suit ceiling construction.
- D. Blades: Galvanized sheet steel with refractory insulation.
- E. Heat-Responsive Device: Replaceable, 165 deg F (74 deg C) rated, fusible links.
- F. Fire Rating: 2 hours.

2.8 SMOKE DAMPERS

- A. Manufacturers: Subject to compliance with requirements, provide products by one of the following:
 - 1. Ruskin Company.
 - 2. Pottorff; a division of PCI Industries, Inc.
- B. General Requirements: Label according to UL 555S by an NRTL.
- C. Frame: Multiple blade type; fabricated with roll-formed, 0.034-inch- (0.85-mm-) thick galvanized steel; with mitered and interlocking corners.
- D. Blades: Airfoil type Roll-formed, horizontal, interlocking, 0.034-inch- (0.85-mm-) thick, galvanized sheet steel. In place of interlocking blades, use full-length, 0.034-inch- (0.85-mm-) thick, galvanized-steel blade connectors.
- E. Leakage: Class I .
- F. Rated pressure and velocity to exceed design airflow conditions.
- G. Mounting Sleeve: Factory-installed, 0.052-inch- (1.3-mm-) thick, galvanized sheet steel; length to suit wall or floor application with factory-furnished silicone caulking.
- H. Provide motor mount bracket strengthener for dampers over 10" in height.
- I. Provide a 10 gauge welded vertical stiffener at each corner to prevent damper misalignment.

- J. Damper Motors: Modulating or two-position action.
- K. Actuators mounted out of the air stream,
- L. Comply with NEMA designation, temperature rating, service factor, enclosure type, and efficiency requirements for motors specified in Division 23 Section "Common Motor Requirements for HVAC Equipment."
 - 1. Motor Sizes: Minimum size as indicated. If not indicated, large enough so driven load will not require motor to operate in service factor range above 1.0.
 - 2. Controllers, Electrical Devices, and Wiring: Comply with requirements for electrical devices and connections specified in Division 23 Section "Instrumentation and Control for HVAC."
 - 3. Permanent-Split-Capacitor or Shaded-Pole Motors: With oil-immersed and sealed gear trains.
 - 4. Spring-Return Motors: Equip with an integral spiral-spring mechanism where indicated. Enclose entire spring mechanism in a removable housing designed for service or adjustments. Size for running torque rating of **150 in. x lbf (17 N x m)** and breakaway torque rating of **150 in. x lbf (17 N x m)**.
 - 5. Outdoor Motors and Motors in Outdoor-Air Intakes: Equip with O-ring gaskets designed to make motors weatherproof. Equip motors with internal heaters to permit normal operation at **minus 40 deg F (minus 40 deg C)**.
 - 6. Electrical Connection: 115 V, single phase, 60 Hz.
- M. Accessories:
 - 1. Auxiliary switches for position indication.
 - 2. Test and reset switches, remotemounted.
- N. The HVAC contractor shall provide all devices, relays, end switches, e/p switches, control components, air piping, power wiring, control wiring and interlock wiring as required to accomplish the sequence of operation for these dampers.
- O. Provide access door in duct adjacent to each combination fire / smoke damper.

2.9 COMBINATION FIRE AND SMOKE DAMPERS

- A. Manufacturers: Subject to compliance with requirements, provide products by one of the following:
 - 1. Pottorff; a division of PCI Industries, Inc., model FSD-151, FSD-341, 1-1/2 or 3 hours rated as applicable
 - 2. Ruskin Company.model FSD-60, 1-1/2 or 3 hour rated as applicable
- B. Type: Dynamic; rated and labeled according to UL 555 and UL 555S by an NRTL.
- C. Closing rating in ducts up to [4-**inch wg** static pressure class and minimum **4000-fpm (20-m/s)** velocity.
- D. Fire Rating: 1-1/2 hours.
- E. Frame: multiblade type fabricated with roll-formed, **0.034-inch- (0.85-mm-)** thick galvanized steel; with mitered and interlocking corners.
- F. Heat-Responsive Device: Replaceable, **165 deg F (74 deg C)** rated, fusible links.
- G. Heat-Responsive Device: Electric resettable link and switch package, factory installed, rated. Provide dual temperature heat responsive device.

- H. Blades: 14 gauge galvanized airfoil shaped double skin, single piece construction, maximum 6 inches wide..
- I. Leakage: Class I .
- J. Rated pressure and velocity to exceed design airflow conditions.
- K. Mounting Sleeve: Factory-installed, **0.052-inch- (1.3-mm-)** thick, galvanized sheet steel; length to suit wall or floor application with factory-furnished silicone caulking.
- L. Provide motor mount bracket strengthener for dampers over 10" in height.
- M. Provide a 10 gauge welded vertical stiffener at each corner to prevent damper misalignment
- N. Master control panel for use in dynamic smoke-management systems.
- O. Damper Motors: Modulating or two-position action.
- P. Actuators mounted out of the air stream,
- Q. Comply with NEMA designation, temperature rating, service factor, enclosure type, and efficiency requirements for motors specified in Division 23 Section "Common Motor Requirements for HVAC Equipment."
 - 1. Motor Sizes: Minimum size as indicated. If not indicated, large enough so driven load will not require motor to operate in service factor range above 1.0.
 - 2. Controllers, Electrical Devices, and Wiring: Comply with requirements for electrical devices and connections specified in Division 23 Section "Instrumentation and Control for HVAC."
 - 3. Permanent-Split-Capacitor or Shaded-Pole Motors: With oil-immersed and sealed gear trains.
 - 4. Spring-Return Motors: Equip with an integral spiral-spring mechanism where indicated. Enclose entire spring mechanism in a removable housing designed for service or adjustments. Size for running torque rating of **150 in. x lbf (17 N x m)** and breakaway torque rating of **150 in. x lbf (17 N x m)**.
 - 5. Outdoor Motors and Motors in Outdoor-Air Intakes: Equip with O-ring gaskets designed to make motors weatherproof. Equip motors with internal heaters to permit normal operation at **minus 40 deg F (minus 40 deg C)**.
 - 6. Electrical Connection: 115 V, single phase, 60 Hz.
- R. Accessories:
 - 1. Auxiliary switches for position indication. Multiple damper sections that are part of the same damper can be wired in series as one large damper indicator.
 - 2. Test and reset switches, remote mounted.
- S. The HVAC contractor shall provide all devices, relays, end switches, e/p switches, control components, air piping, power wiring, control wiring and interlock wiring as required to accomplish the sequence of operation for these dampers.
- T. Provide combination fire / smoke dampers as noted on the plans and in ducts and openings in the following:
 - 1. Shafts.
 - 2. Floors.
 - 3. Fire walls.
 - 4. Fire-resistance partitions.
 - 5. Fire rated ceilings.
 - 6. Exit corridor walls.

- U. Provide access door in duct adjacent to each combination fire / smoke damper.

2.10 TURNING VANES

- A. Manufacturers: Subject to compliance with requirements, provide products by one of the following:
 1. Ductmate Industries, Inc.
 2. Duro Dyne Inc.
 3. METALAIRE, Inc.
 4. SEMCO Incorporated.
- B. Turning Vanes for Metal Ducts: Curved blades of galvanized sheet steel; support with bars perpendicular to blades set; set into vane runners suitable for duct mounting.
 1. Acoustic Turning Vanes: Fabricate airfoil-shaped aluminum extrusions with perforated faces and fibrous-glass fill.
- C. General Requirements: Comply with SMACNA's "HVAC Duct Construction Standards - Metal and Flexible"; "Vaness and Vane Runners," and "Vane Support in Elbows."
- D. Vane Construction: Double wall.
- E. The maximum unsupported vane length shall not exceed 48 inches.
- F. Single vane and short radius vanes are not acceptable.

2.11 REMOTE DAMPER OPERATORS

- A. Manufacturers: Subject to compliance with requirements, provide products by one of the following:
 1. Pottorff; a division of PCI Industries, Inc.
 2. Ventfabrics, Inc.
 3. Young Regulator Company.
- B. Description: Cable system designed for remote manual damper adjustment.
- C. Tubing: Brass.
- D. Cable: Stainless steel.
- E. Wall-Box Mounting: Recessed, 3/4 inches (19 mm) deep
- F. Wall-Box Cover-Plate Material: Stainless steel.

2.12 DUCT-MOUNTED ACCESS DOORS

- A. Manufacturers: Subject to compliance with requirements, provide products by one of the following:
 1. Ductmate Industries, Inc.
 2. Greenheck Fan Corporation.
 3. McGill AirFlow LLC.
 4. Pottorff; a division of PCI Industries, Inc.
 5. Ventfabrics, Inc.
- B. Duct-Mounted Access Doors: Fabricate access panels according to SMACNA's "HVAC Duct Construction Standards - Metal and Flexible"; Figures 2-10, "Duct Access Doors and Panels," and 2-11, "Access Panels - Round Duct."

1. Door:
 - a. Double wall, rectangular.
 - b. Galvanized sheet metal with insulation fill and thickness as indicated for duct pressure class.
 - c. Vision panel.
 - d. Hinges and Latches: **1-by-1-inch (25-by-25-mm)** butt or piano hinge and cam latches.
 - e. Fabricate doors airtight and suitable for duct pressure class.
 2. Frame: Galvanized sheet steel, with bend-over tabs and foam gaskets.
 3. Number of Hinges and Locks:
 - a. Access Doors Less Than **12 Inches (300 mm)** Square: No hinges and two sash locks.
 - b. Access Doors up to **18 Inches (460 mm)** Square: Two hinges and two sash locks.
 - c. Access Doors up to **24 by 48 Inches (600 by 1200 mm)**: Three hinges and two compression latches with outside handles
 - d. Access Doors Larger Than **24 by 48 Inches (600 by 1200 mm)**: Four hinges and two compression latches with outside and inside handles.
- C. Pressure Relief Access Door:
1. Door and Frame Material: Galvanized sheet steel.
 2. Door: Double wall with insulation fill with metal thickness applicable for duct pressure class.
 3. Operation: Open outward for positive-pressure ducts and inward for negative-pressure ducts.
 4. Factory set at **10-inch wg (2500 Pa)**
 5. Doors close when pressures are within set-point range.
 6. Hinge: Continuous piano.
 7. Latches: Cam.
 8. Seal: Neoprene or foam rubber.
 9. Insulation Fill: **1-inch- (25-mm-)** thick, fibrous-glass or polystyrene-foam board.
- 2.13 DUCT ACCESS PANEL ASSEMBLIES
- A. Manufacturers: Subject to compliance with requirements, provide products by one of the following
 1. Ductmate Industries, Inc.
 2. Flame Gard, Inc.
 3. 3M.
 - B. Labeled according to UL 1978 by an NRTL.
 - C. Panel and Frame: Minimum thickness **0.0428-inch (1.1-mm)** stainless steel.
 - D. Fasteners: Stainless steel. Panel fasteners shall not penetrate duct wall.
 - E. Gasket: Comply with NFPA 96; grease-tight, high-temperature ceramic fiber, rated for minimum **2000 deg F (1093 deg C)**.
 - F. Minimum Pressure Rating: **10-inch wg (2500 Pa)**, positive or negative.

2.14 FLEXIBLE CONNECTORS

- A. Manufacturers: Subject to compliance with requirements, provide products by one of the following:
1. Ductmate Industries, Inc.
 2. Duro Dyne Inc.
 3. Ventfabrics, Inc.
- B. Materials: Flame-retardant or noncombustible fabrics.
- C. Coatings and Adhesives: Comply with UL 181, Class 1.
- D. Metal-Edged Connectors: Factory fabricated with a fabric strip 3-1/2 inches (89 mm) wide attached to 2 strips of 2-3/4-inch- (70-mm-) wide, 0.028-inch- (0.7-mm-) thick, galvanized sheet steel or 0.032-inch- (0.8-mm-) thick aluminum sheets. Provide metal compatible with connected ducts.
- E. Indoor System, Flexible Connector Fabric: Glass fabric double coated with neoprene.
1. Minimum Weight: 26 oz./sq. yd. (880 g/sq. m).
 2. Tensile Strength: 480 lbf/inch (84 N/mm) in the warp and 360 lbf/inch (63 N/mm) in the filling.
 3. Service Temperature: Minus 40 to plus 200 deg F (Minus 40 to plus 93 deg C).
- F. Outdoor System, Flexible Connector Fabric: Glass fabric double coated with weatherproof, synthetic rubber resistant to UV rays and ozone.
1. Minimum Weight: 24 oz./sq. yd. (810 g/sq. m).
 2. Tensile Strength: 530 lbf/inch (93 N/mm) in the warp and 440 lbf/inch (77 N/mm) in the filling.
 3. Service Temperature: Minus 50 to plus 250 deg F (Minus 45 to plus 121 deg C).
- G. High-Temperature System, Flexible Connectors: Glass fabric coated with silicone rubber.
1. Minimum Weight: 16 oz./sq. yd. (542 g/sq. m).
 2. Tensile Strength: 285 lbf/inch (50 N/mm) in the warp and 185 lbf/inch (32 N/mm) in the filling.
 3. Service Temperature: Minus 67 to plus 500 deg F (Minus 55 to plus 260 deg C).
- H. High-Corrosive-Environment System, Flexible Connectors: Glass fabric with chemical-resistant coating.
1. Minimum Weight: 14 oz./sq. yd. (474 g/sq. m).
 2. Tensile Strength: 450 lbf/inch (79 N/mm) in the warp and 340 lbf/inch (60 N/mm) in the filling.
 3. Service Temperature: Minus 67 to plus 500 deg F (Minus 55 to plus 260 deg C).
- I. Thrust Limits: Combination coil spring and elastomeric insert with spring and insert in compression, and with a load stop. Include rod and angle-iron brackets for attaching to fan discharge and duct.
1. Frame: Steel, fabricated for connection to threaded rods and to allow for a maximum of 30 degrees of angular rod misalignment without binding or reducing isolation efficiency.
 2. Outdoor Spring Diameter: Not less than 80 percent of the compressed height of the spring at rated load.

3. Minimum Additional Travel: 50 percent of the required deflection at rated load.
4. Lateral Stiffness: More than 80 percent of rated vertical stiffness.
5. Overload Capacity: Support 200 percent of rated load, fully compressed, without deformation or failure.
6. Elastomeric Element: Molded, oil-resistant rubber or neoprene.
7. Coil Spring: Factory set and field adjustable for a maximum of 1/4-inch (6-mm) movement at start and stop.

2.15 DUCT ACCESSORY HARDWARE

- A. Instrument Test Holes: Cast iron or cast aluminum to suit duct material, including screw cap and gasket. Size to allow insertion of pitot tube and other testing instruments and of length to suit duct-insulation thickness.
- B. Adhesives: High strength, quick setting, neoprene based, waterproof, and resistant to gasoline and grease.

PART 3 - EXECUTION

3.1 INSTALLATION

- A. Install duct accessories according to applicable details in SMACNA's "HVAC Duct Construction Standards - Metal and Flexible" for metal ducts and in NAIMA AH116, "Fibrous Glass Duct Construction Standards," for fibrous-glass ducts.
- B. Install duct accessories of materials suited to duct materials; use galvanized-steel accessories in galvanized-steel and fibrous-glass ducts, stainless-steel accessories in stainless-steel ducts, and aluminum accessories in aluminum ducts.
- C. Install backdraft dampers at inlet of exhaust fans or exhaust ducts as close as possible to exhaust fan unless otherwise indicated.
- D. Install volume dampers at points on supply, return, and exhaust systems where branches extend from larger ducts. Where dampers are installed in ducts having duct liner, install dampers with hat channels of same depth as liner, and terminate liner with nosing at hat channel.
 1. Coordinate subparagraphs below with Division 23 Section "Metal Ducts." Install steel volume dampers in steel ducts.
 2. Install aluminum volume dampers in aluminum ducts.
 3. Provide manual balancing volume dampers as required properly balance the air distribution system. If the location of balancing dampers are not defined on the drawings, the following minimum standards shall govern:
 - a. Low Pressure: All supply main air branches from trunk, each split, and all sub branches from main shall be provided with balancing dampers.
 - b. Low Pressure: All exhaust main air branches from trunk, each split, and all sub branches from main shall be provided with balancing dampers.
 - c. Medium Pressure: All branches and takeoffs downstream of terminal boxes (CV, VAV and FPB) shall be provided with balancing dampers.
 - d. Ducts connecting to common plenums.
 - e. Ducts serving single outlet.
 - f. At open return duct in hung ceiling.
 - g. As noted on plans.

4. For internally lined ductwork: Provide 2 internal saddles to protect lining.
 5. Install levers to be accessible through the insulation
- E. Set dampers to fully open position before testing, adjusting, and balancing.
- F. Install test holes at fan inlets and outlets and elsewhere as indicated.
- G. Install, combination fire & smoke fire and smoke dampers according to UL listing.
- H. Install duct security bars. Construct duct security bars from 0.164-inch (4.18-mm) steel sleeve, continuously welded at all joints and 1/2-inch- (13-mm-) diameter steel bars, 6 inches (150 mm) o.c. in each direction in center of sleeve. Weld each bar to steel sleeve and each crossing bar. Weld 2-1/2-by-2-1/2-by-1/4-inch (63-by-63-by-6-mm) steel angle to 4 sides and both ends of sleeve. Connect duct security bars to ducts with flexible connections. Provide 12-by-12-inch (300-by-300-mm) hinged access panel with cam lock in duct in each side of sleeve.
- I. Connect ducts to duct silencers rigidly.
- J. Install duct access doors on sides of ducts to allow for inspecting, adjusting, and maintaining accessories and equipment at the following locations:
1. On both sides of duct coils.
 2. Downstream from manual volume dampers, control dampers, turning vanes, and equipment.
 3. Adjacent to and close enough to fire or smoke dampers, to reset or reinstall fusible links. Access doors for access to fire or smoke dampers having fusible links shall be pressure relief access doors and shall be outward operation for access doors installed upstream from dampers and inward operation for access doors installed downstream from dampers.
 4. At each change in direction and at maximum 50-foot (15-m) spacing.
 5. Upstream of turning vanes.
 6. Elsewhere as indicated.
- K. Install access doors with swing against duct static pressure.
- L. Access Door Sizes:
1. One-Hand or Inspection Access: 8 by 5 inches (200 by 125 mm).
 2. Two-Hand Access: 12 by 6 inches (300 by 150 mm).
 3. Head and Hand Access: 18 by 10 inches (460 by 250 mm).
 4. Head and Shoulders Access: 21 by 14 inches (530 by 355 mm).
 5. Body Access: 25 by 14 inches (635 by 355 mm).
 6. Body plus Ladder Access: 25 by 17 inches (635 by 430 mm).
- M. Label access doors according to Division 23 Section "Identification for HVAC Piping and Equipment" to indicate the purpose of access door.
- N. Install flexible connectors to connect ducts to equipment.
- O. For fans developing static pressures of 5-inch wg (1250 Pa) and more, cover flexible connectors with loaded vinyl sheet held in place with metal straps.
- P. Connect terminal units to supply ducts directly. Do not use flexible ducts. Provide flexible connections for all fan powered terminal boxes.
- Q. Connect diffusers to low-pressure ducts directly.
- R. Install duct test holes where required for testing and balancing purposes.

- S. Install thrust limits at centerline of thrust, symmetrical on both sides of equipment. Attach thrust limits at centerline of thrust and adjust to a maximum of **1/4-inch (6-mm)** movement during start and stop of fans.

3.2 FIELD QUALITY CONTROL

- A. Tests and Inspections:
 - 1. Operate dampers to verify full range of movement.
 - 2. Inspect locations of access doors and verify that purpose of access door can be performed.
 - 3. Operate fire, smoke, and combination fire and smoke dampers to verify full range of movement and verify that proper heat-response device is installed.
 - 4. Inspect turning vanes for proper and secure installation.
 - 5. Operate remote damper operators to verify full range of movement of operator and damper.

END OF SECTION

This page is intentionally left blank.

SECTION 23 34 16

CENTRIFUGAL HVAC FANS

PART 1 - GENERAL

1.1 RELATED DOCUMENTS

- A. Drawings and general provisions of the Contract, including General and Supplementary Conditions and Division 01 Specification Sections, apply to this Section.
- B. Section 01 81 13 "Sustainable Design Requirements – LEED v4 for Building Design & Construction – New Construction" for sustainable design requirements and detailed sustainable design submittal requirements.
- C. Section 01 74 19 "Construction and Demolition Waste Management and Disposal" for disposal of construction, demolition and packaging waste disposal requirements.

1.2 SUMMARY

- A. This Section includes the following:
 - 1. Airfoil centrifugal fans.
 - 2. Backward-inclined centrifugal fans.
 - 3. Laboratory exhaust fans
- B. Sustainable Building Requirements:
 - 1. The Owner requires the Contractor to implement practices and procedures to meet the project's environmental performance goals, which include achieving LEED version 4 **Certified** level Certification. Specific project goals that may impact this area of work include: use of recycled-content materials; use of locally-manufactured materials; use of low-emitting materials; construction waste recycling; and the implementation of a construction indoor air quality management plan. The Contractor shall ensure that the requirements related to these goals, as defined in the Articles below, are implemented to the fullest extent. Substitutions, or other changes to the work proposed by the Contractor or their Subcontractors, shall not be allowed if such changes compromise the aforementioned environmental goals and LEED certification.

1.3 PERFORMANCE REQUIREMENTS

- A. Project Altitude: Base fan performance ratings on sea level.
- B. Operating Limits: Classify according to AMCA 99.

1.4 SUBMITTALS

- A. Product Data: Include rated capacities, furnished specialties, and accessories for each type of product indicated and include the following:
 - 1. Certified fan performance curves with system operating conditions indicated.

2. Submit the family of rpm curves indicating operating point relative to fan class.
 3. Drive construction and rating.
 4. Catalog cuts and dimension drawings.
 5. Submit all selected sheave (fan and motor) calculations.
 6. Correction chart for fans equipped with variable inlet vanes indicating performance at various percentage of opening.
 7. VFD application: Submit fan selection with system curve indication, operating point, family of all rpm curves in fan class and the "DO NOT SELECT TO THE LEFT OF THIS CURVE". The minimum rpm shall be indicated.
 8. Certified fan sound-power ratings.
 9. Motor ratings and electrical characteristics, plus motor and electrical accessories.
 10. Material thickness and finishes, including color charts.
 11. Dampers, including housings, linkages, and operators.
 12. Roof curbs
- B. Shop Drawings: Detail equipment assemblies and indicate dimensions, weights, loads, required clearances, method of field assembly, components, and location and size of each field connection.
1. Wiring Diagrams: Power, signal, and control wiring.
 2. Design Calculations: Calculate requirements for selecting vibration isolators and seismic restraints and for designing vibration isolation bases.
 3. Vibration Isolation Base Details: Detail fabrication, including anchorages and attachments to structure and to supported equipment. Include auxiliary motor slides and rails, and base weights.
- C. Coordination Drawings: Show fan room layout and relationships between components and adjacent structural and mechanical elements. Show support locations, type of support, and weight on each support. Indicate and certify field measurements.
- D. Field quality-control test reports.
- E. Operation and Maintenance Data: For centrifugal fans to include in emergency, operation, and maintenance manuals.
- 1.5 QUALITY ASSURANCE
- A. Electrical Components, Devices, and Accessories: Listed and labeled as defined in NFPA 70, Article 100, by a testing agency acceptable to authorities having jurisdiction, and marked for intended use.
- B. AMCA Compliance: Products shall comply with performance requirements and shall be licensed to use the AMCA-Certified Ratings Seal.
1. Test and rate all fans in accordance with the standards of AMCA. All fans shall bear the AMCA rating and seal.
- C. NEMA Compliance: Motors and electrical accessories shall comply with NEMA 1.
- 1.6 DELIVERY, STORAGE, AND HANDLING
- A. Deliver fans as factory-assembled units, to the extent allowable by shipping limitations, with protective crating and covering.

- B. Disassemble and reassemble units, as required for moving to the final location, according to manufacturer's written instructions.
- C. Lift and support units with manufacturer's designated lifting or supporting points.

1.7 COORDINATION

- A. Coordinate size and location of structural-steel support members.
- B. Coordinate size and location of concrete bases. Cast anchor-bolt inserts into bases. Concrete, reinforcement, and formwork requirements are specified in Division 03.
- C. Coordinate installation of roof curbs, equipment supports, and roof penetrations. These items are specified in Division 07 Section "Roof Accessories."

PART 2 - PRODUCTS

2.1 GENERAL

- A. Make appropriate allowances for the effects on fan performance of all installation conditions including plenum enclosures and inlet and discharge arrangements so that actual installed fan performance equals that specified.
- B. Fans shall be non-overloading and operate stably without surging at design conditions.
- C. Fan characteristic curves provided by manufacturer must be such that that the fan operating point:
 - 1. Is to the right of peak efficiency.
 - 2. Is on the steep part of the fan curve such that an increase in static pressure over the specified duty results in not more than the same percent decrease in volume (CFM) and does not affect the stability of fan operation.
 - 3. Is no greater than 60 to 70 percent of the peak static pressure.
 - 4. Has the ability to provide an allowable increase in fan speed of 15 percent above the design point without surging or increasing the class of fan.
- D. Provide non-overloading design, except as noted with minimum capacities as noted and with certified ratings by AMCA.
- E. Wheel shall be factory balanced statically and dynamically. Brake horsepower ratings shall be 5 percent maximum above those noted and published for a minimum of two (2) years.
- F. Fans shall be direct drive with motors provided with sealed bearings.
- G. Provide removable flanged screens at inlets or outlets where no connecting ductwork is indicated, including inlets to fans in field erected casings.
- H. Split construction: Provide split construction for fans too large for available doorways or passageways. Split in half along center of shaft with angles, etc., to allow removal of section without disturbing inlet and discharge connection; arranged for bolting. Provide bolts with lockwashers and nuts. Construction shall be inspected by manufacturer after field assembly and certified that they have been properly assembled and ready for proper operation.
- I. The drive end of the fan shaft shall be countersunk for tachometer readings.

- J. For all fans located outdoors, except roof ventilators exposed to the weather, provide custom fitted weather guards completely enclosing the fan motor, drive and bearings. Provide weatherproof louvers in the enclosure to permit circulation of air but to exclude rain and snow. Arrange one side of the enclosure to be completely removable for access to motors, drives, bearings and other equipment located within requiring maintenance. Construct the enclosure of 16 gauge aluminum, braced with aluminum angles. Paint the fan exterior with two coats of weatherproof aluminum paint.

2.2 AIRFOIL CENTRIFUGAL FANS

- A. Manufacturers: Subject to compliance with requirements, provide products by one of the following:
 - 1. Greenheck
 - 2. Loren Cook Company.
- B. Description: Factory-fabricated, -assembled, -tested, and -finished, belt-driven centrifugal fans consisting of housing, wheel, fan shaft, bearings, motor and disconnect switch, drive assembly, and support structure.
 - 1. The fan shall be of welded construction utilizing corrosion resistant fasteners. The scroll wrapper and scroll side panels shall be minimum 12 gauge steel (minimum 8 gauge steel for Class III).
- C. Housings: Formed panels to make curved-scroll housings with shaped cutoff, with doors or panels to allow access to internal parts and components.
 - 1. The entire fan housing shall have continuously welded seams for leak proof operation and shall have a minimum 1-1/2 inch outlet discharge flange. A performance cut-off shall be furnished to prevent the recirculation of air in the fan housing. Bearing support shall be minimum 1/4 inch steel. Lifting lugs shall be provided for ease of installation. Unit shall bear an engraved aluminum nameplate and shall be shipped in ISTA certified transit tested packaging.
 - 2. Panel Bracing: Steel angle- or channel-iron member supports for mounting and supporting fan scroll, wheel, motor, and accessories.
 - 3. Spun inlet cone with flange.
 - 4. Outlet flange.
- D. Airfoil Wheels: Single-width-single-inlet and double-width-double-inlet construction with curved inlet flange; heavy backplate; hollow die-formed, airfoil-shaped blades continuously welded at tip flange and backplate; and cast-iron or cast-steel hub riveted to backplate and fastened to shaft with set screws.
- E. Shafts: Statically and dynamically balanced and selected for continuous operation at maximum rated fan speed and motor horsepower, with final alignment made after installation.
 - 1. Turned, ground, and polished hot-rolled steel with keyway. Ship with protective coating of lubricating oil.
 - 2. Designed to operate at no more than 70 percent of first critical speed at top of fan's speed range.
- F. Accessories:
 - 1. Scroll Access Doors: Shaped to conform to scroll, with quick-opening latches and gaskets.
 - 2. Cleanout Door: Quick-opening, latch-type gasketed door allowing access to fan scroll, of same material as housing.

3. Scroll Drain Connection: NPS 1 (DN 25) steel pipe coupling welded to low point of fan scroll.
 4. Companion Flanges: Rolled flanges for duct connections of same material as housing.
 5. Discharge Dampers: Assembly with opposed blades constructed of two plates formed around and to shaft, channel frame, and sealed ball bearings; with blades linked outside of airstream to single control lever of same material as housing.
 6. Inlet Screens: Grid screen of same material as housing.
 7. Shaft Seals: Airtight seals installed around shaft on drive side of single-width fans.
 8. Weather Cover: Enameled-steel sheet with ventilation slots, bolted to housing.
- G. Motors: Comply with requirements in Division 23 Section "Common Motor Requirements for HVAC Equipment."
1. Enclosure Type: Totally enclosed, fan cooled.

2.3 BACKWARD-INCLINED CENTRIFUGAL FANS

- A. Manufacturers: Subject to compliance with requirements, provide products by one of the following:
1. Loren Cook Company.
 2. Greenheck
- B. Description: Factory-fabricated, -assembled, -tested, and -finished, belt-driven centrifugal fans consisting of housing, wheel, fan shaft, bearings, motor and disconnect switch, drive assembly, and support structure.
- C. Housings: Formed panels to make curved-scroll housings with shaped cutoff; with doors or panels to allow access to internal parts and components.
1. Panel Bracing: Steel angle- or channel-iron member supports for mounting and supporting fan scroll, wheel, motor, and accessories.
 2. Spun inlet cone with flange.
 3. Outlet flange.
- D. Backward-Inclined Wheels: Single-width-single-inlet and double-width-double-inlet construction with curved inlet flange, backplate, backward-inclined blades welded or riveted to flange and backplate; cast-iron or cast-steel hub riveted to backplate and fastened to shaft with set screws.
- E. Shafts: Statically and dynamically balanced and selected for continuous operation at maximum rated fan speed and motor horsepower, with final alignment and belt adjustment made after installation.
1. Turned, ground, and polished hot-rolled steel with keyway. Ship with a protective coating of lubricating oil.
 2. Designed to operate at no more than 70 percent of first critical speed at top of fan's speed range.
- F. Accessories:
1. Scroll Access Doors: Shaped to conform to scroll, with quick-opening latches and gaskets.
 2. Cleanout Door: Quick-opening, latch-type gasketed door allowing access to fan scroll, of same material as housing.

3. Scroll Drain Connection: NPS 1 (DN 25) steel pipe coupling welded to low point of fan scroll.
 4. Companion Flanges: Rolled flanges for duct connections of same material as housing.
 5. Discharge Dampers: Assembly with opposed blades constructed of two plates formed around and to shaft, channel frame, and sealed ball bearings; with blades linked outside of airstream to single control lever of same material as housing.
 6. Inlet Screens: Grid screen of same material as housing.
 7. Shaft Seals: Airtight seals installed around shaft on drive side of single-width fans.
 8. Weather Cover: Enameled-steel sheet with ventilation slots, bolted to housing
- G. Motors: Comply with requirements in Division 23 Section "Common Motor Requirements for HVAC Equipment."
1. Enclosure Type: Totally enclosed, fan cooled.

2.4 SOURCE QUALITY CONTROL

- A. Sound-Power Level Ratings: Comply with AMCA 301, "Methods for Calculating Fan Sound Ratings from Laboratory Test Data." Factory test fans according to AMCA 300, "Reverberant Room Method for Sound Testing of Fans." Label fans with the AMCA-Certified Ratings Seal.
- B. Fan Performance Ratings: Establish flow rate, pressure, power, air density, speed of rotation, and efficiency by factory tests and ratings according to AMCA 210, "Laboratory Methods of Testing Fans for Rating."

PART 3 - EXECUTION

3.1 INSTALLATION

- A. Install centrifugal fans level and plumb.
- B. Support floor-mounting units using spring isolators having a static deflection of 1 inch (25 mm). Vibration- and seismic-control devices are specified in Division 23 Section "Vibration and Seismic Controls for HVAC Piping and Equipment."
 1. Secure vibration and seismic controls to concrete bases using anchor bolts cast in concrete base.
- C. Install floor-mounting units on concrete bases. Concrete, reinforcement, and formwork requirements are specified in Division 03 Section "Cast-in-Place Concrete."
- D. Install floor-mounting units on concrete bases designed to withstand, without damage to equipment, the seismic force required by authorities having jurisdiction. Concrete, reinforcement, and formwork requirements are specified in Division 03 Section "Cast-in-Place Concrete."
- E. Support suspended units from structure using threaded steel rods and spring hangers having a static deflection of 1 inch (25 mm). Vibration-control devices are specified in Division 23 Section "Vibration and Seismic Controls for HVAC Piping and Equipment."

- F. Install units with clearances for service and maintenance.
- G. Label fans according to requirements specified in Division 23 Section "Identification for HVAC Piping and Equipment."

3.2 CONNECTIONS

- A. Duct installation and connection requirements are specified in other Division 23 Sections. Drawings indicate general arrangement of ducts and duct accessories. Make final duct connections with flexible connectors. Flexible connectors are specified in Division 23 Section "Air Duct Accessories."
- B. Install ducts adjacent to fans to allow service and maintenance.
- C. Install line-sized piping from scroll drain connection, with trap with seal equal to 1.5 times specified static pressure, to nearest floor drain.
- D. Ground equipment according to Division 26 Section "Grounding and Bonding for Electrical Systems."
- E. Connect wiring according to Division 26 Section "Low-Voltage Electrical Power Conductors and Cables."

3.3 FIELD QUALITY CONTROL

- A. Perform the following field tests and inspections and prepare test reports:
 - 1. Verify that shipping, blocking, and bracing are removed.
 - 2. Verify that unit is secure on mountings and supporting devices and that connections to ducts and electrical components are complete. Verify that proper thermal-overload protection is installed in motors, starters, and disconnect switches.
 - 3. Verify that cleaning and adjusting are complete.
 - 4. Disconnect fan drive from motor, verify proper motor rotation direction, and verify fan wheel free rotation and smooth bearing operation. Reconnect fan drive system, align and adjust belts, and install belt guards.
 - 5. Adjust belt tension.
 - 6. Adjust damper linkages for proper damper operation.
 - 7. Verify lubrication for bearings and other moving parts.
 - 8. Balance all fan wheels and all other moving components statically and dynamically. Where a coating is specified and it affects the balance of the fan wheel, perform the balancing after the coating has been applied.
 - 9. Verify that manual and automatic volume control and fire and smoke dampers in connected ductwork systems are in fully open position.
 - 10. Refer to Division 23 Section "Testing, Adjusting, and Balancing for HVAC" for testing, adjusting, and balancing procedures.
 - 11. Disable automatic temperature-control operators, energize motor and confirm proper motor rotation and unit operation, adjust fan to indicated rpm, and measure and record motor voltage and amperage.
 - 12. For units with variable frequency drives lock out critical frequencies before initial start.
 - 13. Operational Test: After electrical circuitry has been energized, start units to confirm proper motor rotation and unit operation.
 - 14. Replace fan and motor pulleys as required to achieve design airflow.
 - 15. Shut unit down and reconnect automatic temperature-control operators.
 - 16. Remove and replace malfunctioning units and retest as specified above.

- B. Test and adjust controls and safeties. Replace damaged and malfunctioning controls and equipment.

3.4 ADJUSTING

- A. Adjust damper linkages for proper damper operation.
- B. Adjust belt tension.
- C. Lubricate bearings
- D. Refer to Division 23 Section "Testing, Adjusting, and Balancing for HVAC" for testing, adjusting, and balancing procedures.
- E. Replace fan and motor pulleys as required to achieve design airflow.

3.5 DEMONSTRATION

- A. Train Owner's maintenance personnel to adjust, operate, and maintain centrifugal fans. Refer to Division 01 Section "Demonstration and Training."

END OF SECTION

SECTION 23 34 23

HVAC POWER VENTILATORS

PART 1 - GENERAL

1.1 RELATED DOCUMENTS

- A. Drawings and general provisions of the Contract, including General and Supplementary Conditions and Division 01 Specification Sections, apply to this Section.
- B. Section 01 81 13 "Sustainable Design Requirements – LEED v4 for Building Design & Construction – New Construction" for sustainable design requirements and detailed sustainable design submittal requirements.
- C. Section 01 74 19 "Construction and Demolition Waste Management and Disposal" for disposal of construction, demolition and packaging waste disposal requirements

1.2 SUMMARY

- A. This Section includes the following:
 - 1. Utility set fans.
 - 2. Centrifugal roof ventilators.
 - 3. Ceiling-mounting ventilators.
 - 4. In-line centrifugal fans.
 - 5. Propeller fans.
- B. Sustainable Building Requirements:
 - 1. The Owner requires the Contractor to implement practices and procedures to meet the project's environmental performance goals, which include achieving LEED version 4 **Certified** level Certification. Specific project goals that may impact this area of work include: use of recycled-content materials; use of locally-manufactured materials; use of low-emitting materials; construction waste recycling; and the implementation of a construction indoor air quality management plan. The Contractor shall ensure that the requirements related to these goals, as defined in the Articles below, are implemented to the fullest extent. Substitutions, or other changes to the work proposed by the Contractor or their Subcontractors, shall not be allowed if such changes compromise the aforementioned environmental goals and LEED certification.

1.3 PERFORMANCE REQUIREMENTS

- A. Project Altitude: Base fan-performance ratings on sea level.
- B. Operating Limits: Classify according to AMCA 99.

1.4 SUBMITTALS

- A. Product Data: Include rated capacities, furnished specialties, and accessories for each type of product indicated and include the following:

1. Certified fan performance curves with system operating conditions indicated.
 2. Submit the family of rpm curves indicating operating point relative to fan class.
 3. Drive construction and rating.
 4. Catalog cuts and dimension drawings.
 5. Submit all selected sheave (fan and motor) calculations.
 6. Correction chart for fans equipped with variable inlet vanes indicating performance at various percentage of opening.
 7. VFD application: Submit fan selection with system curve indication, operating point, family of all rpm curves in fan class and the "DO NOT SELECT TO THE LEFT OF THIS CURVE". The minimum rpm shall be indicated.
 8. Certified fan sound-power ratings.
 9. Motor ratings and electrical characteristics, plus motor and electrical accessories.
 10. Material thickness and finishes, including color charts.
 11. Dampers, including housings, linkages, and operators.
 12. Roof curbs.
 13. Fan speed controllers.
- B. Shop Drawings: Detail equipment assemblies and indicate dimensions, weights, loads, required clearances, method of field assembly, components, and location and size of each field connection.
1. Wiring Diagrams: Power, signal, and control wiring.
 2. Design Calculations: Calculate requirements for selecting vibration isolators and seismic restraints and for designing vibration isolation bases.
 3. Vibration Isolation Base Details: Detail fabrication, including anchorages and attachments to structure and to supported equipment. Include auxiliary motor slides and rails, and base weights.
- C. Coordination Drawings: Reflected ceiling plans and other details, drawn to scale, on which the following items are shown and coordinated with each other, based on input from installers of the items involved:
1. Roof framing and support members relative to duct penetrations.
 2. Ceiling suspension assembly members.
 3. Size and location of initial access modules for acoustical tile.
 4. Ceiling-mounted items including light fixtures, diffusers, grilles, speakers, sprinklers, access panels, and special moldings.
- D. Field quality-control test reports.
- E. Operation and Maintenance Data: For power ventilators to include in emergency, operation, and maintenance manuals.
- 1.5 QUALITY ASSURANCE
- A. Electrical Components, Devices, and Accessories: Listed and labeled as defined in NFPA 70, Article 100, by a testing agency acceptable to authorities having jurisdiction, and marked for intended use.
- B. AMCA Compliance: Products shall comply with performance requirements and shall be licensed to use the AMCA-Certified Ratings Seal.
1. Test and rate all fans in accordance with the standards of AMCA. All fans shall bear the AMCA rating and seal.

- C. NEMA Compliance: Motors and electrical accessories shall comply with NEMA standards.
- D. UL Standard: Power ventilators shall comply with UL 705.

1.6 DELIVERY, STORAGE, AND HANDLING

- A. Deliver fans as factory-assembled unit, to the extent allowable by shipping limitations, with protective crating and covering.
- B. Disassemble and reassemble units, as required for moving to final location, according to manufacturer's written instructions.
- C. Lift and support units with manufacturer's designated lifting or supporting points.

1.7 COORDINATION

- A. Coordinate size and location of structural-steel support members.
- B. Coordinate size and location of concrete bases. Cast anchor-bolt inserts into bases. Concrete, reinforcement, and formwork requirements are specified in Division 03.
- C. Coordinate installation of roof curbs, equipment supports, and roof penetrations. These items are specified in Division 07 Section "Roof Accessories."

PART 2 - PRODUCTS

2.1 GENERAL

- A. Make appropriate allowances for the effects on fan performance of all installation conditions including plenum enclosures and inlet and discharge arrangements so that actual installed fan performance equals that specified.
- B. Fans shall be non-overloading and operate stably without surging at design conditions.
- C. Fan characteristic curves provided by manufacturer must be such that that the fan operating point:
 - 1. Is to the right of peak efficiency.
 - 2. Is on the steep part of the fan curve such that an increase in static pressure over the specified duty results in not more than the same percent decrease in volume (CFM) and does not affect the stability of fan operation.
 - 3. Is no greater than 60 to 70 percent of the peak static pressure.
 - 4. Has the ability to provide an allowable increase in fan speed of 15 percent above the design point without surging or increasing the class of fan.
- D. Provide non-overloading design, except as noted with minimum capacities as noted and with certified ratings by AMCA. Where variable inlet vanes are used, complete assembly shall be factory installed by the fan manufacturer. The fan horsepower performance characteristics shall be within 5 percent of published catalog rating data of the standard fan.
- E. Wheel shall be factory balanced statically and dynamically. Brake horsepower ratings shall be 5 percent maximum above those noted and published for a minimum of two (2) years.

- F. Fans shall be direct drive with motors provided with sealed bearings.
- G. Provide removable flanged screens at inlets or outlets where no connecting ductwork is indicated, including inlets to fans in field erected casings.
- H. The drive end of the fan shaft shall be countersunk for tachometer readings.
- I. For all fans located outdoors, except roof ventilators exposed to the weather, provide custom fitted weather guards completely enclosing the fan motor, drive and bearings. Provide weatherproof louvers in the enclosure to permit circulation of air but to exclude rain and snow. Arrange one side of the enclosure to be completely removable for access to motors, drives, bearings and other equipment located within requiring maintenance. Construct the enclosure of 16 gauge aluminum, braced with aluminum angles. Paint the fan exterior with two coats of weatherproof aluminum paint.

2.2 UTILITY SET FANS

- A. Manufacturers: Subject to compliance with requirements, provide products by one of the following:
 - 1. Loren Cook Company.
 - 2. Greenheck
- B. Description: Direct-driven centrifugal fans consisting of housing, wheel, fan shaft, , motor and disconnect switch, drive assembly, and accessories.
 - 1. The fan shall be of welded construction utilizing corrosion resistant fasteners. The scroll wrapper and scroll side panels shall be minimum 12 gauge steel (minimum 8 gauge steel for Class III).
- C. Housing: Fabricated of galvanized steel with side sheets fastened with a deep lock seam or welded to scroll sheets.
 - 1. The entire fan housing shall have continuously welded seams for leak proof operation and shall have a minimum 1-1/2 inch outlet discharge flange. A performance cut-off shall be furnished to prevent the recirculation of air in the fan housing. Bearing support shall be minimum 1/4 inch steel. Lifting lugs shall be provided for ease of installation. Unit shall bear an engraved aluminum nameplate and shall be shipped in ISTA certified transit tested packaging.
 - 2. Housing Discharge Arrangement: Adjustable to eight standard positions.
- D. Fan Wheels: Single-width, single inlet; welded to cast-iron or cast-steel hub and spun-steel inlet cone, with hub keyed to shaft.
 - 1. Blade Materials: Steel.
 - 2. Blade Type: Backward inclined or Airfoil per the schedule.
- E. Fan Shaft: Turned, ground, and polished steel; keyed to wheel hub.
- F. Direct Drive with motor provided with sealed bearings.
- G. Accessories:
 - 1. Disconnect Switch: Nonfusible type, with thermal-overload protection mounted inside fan housing, factory wired through an internal aluminum conduit. Provide NEMA 3R enclosure on all units mounted outside of fan enclosure.
 - 2. Inlet and Outlet: Flanged.
 - 3. Companion Flanges: Rolled flanges for duct connections of same material as housing.

4. Backdraft Dampers: Gravity actuated with counterweight and interlocking aluminum blades with felt edges in steel frame installed on fan discharge.
5. Access Door: Gasketed door in scroll with latch-type handles.
6. Scroll Dampers: Single-blade damper installed at fan scroll top with adjustable linkage.
7. Inlet Screens: Removable wire mesh.
8. Drain Connections: NPS 3/4 (DN 20) threaded coupling drain connection installed at lowest point of housing.
9. Weather Hoods: Weather resistant with stamped vents over motor and drive compartment.
10. Discharge Dampers: Assembly with opposed blades constructed of two plates formed around and to shaft, channel frame, sealed ball bearings, with blades linked outside of airstream to single control lever of same material as housing.

H. Coatings: Powder-baked enamel.

2.3 CENTRIFUGAL ROOF VENTILATORS

- A. Manufacturers: Subject to compliance with requirements, provide products by one of the following:
 1. Greenheck.
 2. Loren Cook Company.
- B. Description: Direct- or belt-driven centrifugal fans consisting of housing, wheel, fan shaft, bearings, motor and disconnect switch, drive assembly, curb base, and accessories.
- C. Housing: Removable, spun-aluminum, dome top and outlet baffle; square, one-piece, aluminum base with venturi inlet cone.
 1. Upblast Units: Provide spun-aluminum discharge baffle to direct discharge air upward, with rain and snow drains.
 2. Hinged Subbase: Galvanized-steel hinged arrangement permitting service and maintenance.
- D. Fan Wheels: Aluminum hub and wheel with backward-inclined blades.
- E. Direct-Driven Drive Assembly with motors provided with sealed bearings.
- F. Accessories:
 1. Disconnect Switch: Nonfusible type, with thermal-overload protection mounted outside fan housing, factory wired through an internal aluminum conduit.
 2. Bird Screens: Removable, 1/2-inch (13-mm) mesh, aluminum or brass wire.
 3. Dampers: Counterbalanced, parallel-blade, backdraft dampers mounted in curb base; factory set to close when fan stops.
 4. Motorized Dampers: Parallel-blade dampers mounted in curb base with electric actuator; wired to close when fan stops.
- G. Roof Curbs: Galvanized steel; mitered and welded corners; 1-1/2-inch- (40-mm-) thick, rigid, fiberglass insulation adhered to inside walls; and 1-1/2-inch (40-mm) wood nailer. Size as required to suit roof opening and fan base.
 1. Configuration: Self-flashing without a cant strip, with mounting flange.
 2. Overall Height: 12 inches (300 mm).
 3. Pitch Mounting: Manufacture curb for roof slope.
 4. Metal Liner: Galvanized steel.

5. Mounting Pedestal: Galvanized steel with removable access panel.

2.4 CEILING-MOUNTING VENTILATORS

- A. Manufacturers: Subject to compliance with requirements, provide products by one of the following:
 1. Greenheck.
 2. Loren Cook Company.
- B. Description: Centrifugal fans designed for installing in ceiling or wall or for concealed in-line applications.
- C. Housing: Steel, lined with acoustical insulation.
- D. Fan Wheel: Centrifugal wheels directly mounted on motor shaft. Fan shrouds, motor, and fan wheel shall be removable for service.
- E. Grille: Painted aluminum, louvered grille with flange on intake and thumbscrew attachment to fan housing.
- F. Electrical Requirements: Junction box for electrical connection on housing and receptacle for motor plug-in.
- G. Accessories:
 1. Variable-Speed Controller: Solid-state control to reduce speed from 100 to less than 50 percent.
 2. Manual Starter Switch: Single-pole rocker switch assembly with cover and pilot light.
 3. Time-Delay Switch: Assembly with single-pole rocker switch, timer, and cover plate.
 4. Motion Sensor: Motion detector with adjustable shutoff timer.
 5. Filter: Washable aluminum to fit between fan and grille.
 6. Isolation: Rubber-in-shear vibration isolators.
 7. Manufacturer's standard roof jack or wall cap, and transition fittings.

2.5 IN-LINE CENTRIFUGAL FANS

- A. Manufacturers: Subject to compliance with requirements, provide products by one of the following:
 1. Greenheck.
 2. Loren Cook Company.
- B. Description: In-line, belt-driven centrifugal fans consisting of housing, wheel, outlet guide vanes, fan shaft, bearings, motor and disconnect switch, drive assembly, mounting brackets, and accessories.
- C. Housing: Split, spun aluminum with aluminum straightening vanes, inlet and outlet flanges, and support bracket adaptable to floor, side wall, or ceiling mounting.
- D. Direct-Driven Units: Provide motor with sealed bearings.
- E. Fan Wheels: Aluminum, airfoil blades welded to aluminum hub.
- F. Accessories:
 1. Volume-Control Damper: Manually operated with quadrant lock, located in fan outlet.
 2. Companion Flanges: For inlet and outlet duct connections.

2.6 MOTORS

- A. Comply with requirements in Division 23 Section "Common Motor Requirements for HVAC Equipment."
- B. Enclosure Type: Totally enclosed, fan cooled.

2.7 SOURCE QUALITY CONTROL

- A. Sound-Power Level Ratings: Comply with AMCA 301, "Methods for Calculating Fan Sound Ratings from Laboratory Test Data." Factory test fans according to AMCA 300, "Reverberant Room Method for Sound Testing of Fans." Label fans with the AMCA-Certified Ratings Seal.
- B. Fan Performance Ratings: Establish flow rate, pressure, power, air density, speed of rotation, and efficiency by factory tests and ratings according to AMCA 210, "Laboratory Methods of Testing Fans for Rating."

PART 3 - EXECUTION

3.1 INSTALLATION

- A. Install power ventilators level and plumb.
- B. Support units using spring isolators having a static deflection of 1 inch (25 mm). Vibration- and seismic-control devices are specified in Division 23 Section "Vibration and Seismic Controls for HVAC Piping and Equipment."
 - 1. Secure vibration and seismic controls to concrete bases using anchor bolts cast in concrete base.
- C. Install floor-mounting units on concrete bases. Concrete, reinforcement, and formwork requirements are specified in Division 03 Section "Cast-in-Place Concrete."
- D. Install floor-mounting units on concrete bases designed to withstand, without damage to equipment, the seismic force required by code. Concrete, reinforcement, and formwork requirements are specified in Division 03 Section "Cast-in-Place Concrete."
- E. Secure roof-mounting fans to roof curbs with cadmium-plated hardware. Refer to Division 07 Section "Roof Accessories" for installation of roof curbs.
- F. Ceiling Units: Suspend units from structure; use steel wire or metal straps.
- G. Support suspended units from structure using threaded steel rods and spring hangers having a static deflection of 1 inch (25 mm). Vibration-control devices are specified in Division 23 Section "Vibration and Seismic Controls for HVAC Piping and Equipment."
- H. Install units with clearances for service and maintenance.
- I. Label units according to requirements specified in Division 23 Section "Identification for HVAC Piping and Equipment."

3.2 CONNECTIONS

- A. Duct installation and connection requirements are specified in other Division 23 Sections. Drawings indicate general arrangement of ducts and duct accessories. Make final duct connections with flexible connectors. Flexible connectors are specified in Division 23 Section "Air Duct Accessories."
- B. Install ducts adjacent to power ventilators to allow service and maintenance.
- C. Ground equipment according to Division 26 Section "Grounding and Bonding for Electrical Systems."
- D. Connect wiring according to Division 26 Section "Low-Voltage Electrical Power Conductors and Cables."

3.3 FIELD QUALITY CONTROL

- A. Perform the following field tests and inspections and prepare test reports:
 - 1. Verify that shipping, blocking, and bracing are removed.
 - 2. Verify that unit is secure on mountings and supporting devices and that connections to ducts and electrical components are complete. Verify that proper thermal-overload protection is installed in motors, starters, and disconnect switches.
 - 3. Verify that cleaning and adjusting are complete.
 - 4. Disconnect fan drive from motor, verify proper motor rotation direction, and verify fan wheel free rotation and smooth bearing operation. Reconnect fan drive system, align and adjust belts, and install belt guards.
 - 5. Adjust damper linkages for proper damper operation.
 - 6. Verify lubrication for bearings and other moving parts.
 - 7. Balance all fan wheels and all other moving components statically and dynamically. Where a coating is specified and it affects the balance of the fan wheel, perform the balancing after the coating has been applied.
 - 8. Verify that manual and automatic volume control and fire and smoke dampers in connected ductwork systems are in fully open position.
 - 9. Refer to Division 23 Section "Testing, Adjusting, and Balancing for HVAC" for testing, adjusting, and balancing procedures.
 - 10. Disable automatic temperature-control operators, energize motor and confirm proper motor rotation and unit operation, adjust fan to indicated rpm, and measure and record motor voltage and amperage.
 - 11. For units with variable frequency drives lock out critical frequencies before initial start.
 - 12. Operational Test: After electrical circuitry has been energized, start units to confirm proper motor rotation and unit operation.
 - 13. Shut unit down and reconnect automatic temperature-control operators.
 - 14. Remove and replace malfunctioning units and retest as specified above.
- B. Test and adjust controls and safeties. Replace damaged and malfunctioning controls and equipment.

3.4 ADJUSTING

- A. Adjust damper linkages for proper damper operation.
- B. Refer to Division 23 Section "Testing, Adjusting, and Balancing for HVAC" for testing, adjusting, and balancing procedures.

3.5 DEMONSTRATION

- A. Train Owner's maintenance personnel to adjust, operate, and maintain centrifugal fans. Refer to Division 01 Section "Demonstration and Training."

END OF SECTION

This page is intentionally left blank.

SECTION 23 36 00

AIR TERMINAL UNITS

PART 1 - GENERAL

1.1 RELATED DOCUMENTS

- A. Drawings and general provisions of the Contract, including General and Supplementary Conditions and Division 01 Specification Sections, apply to this Section.
- B. Sustainable Building Requirements:
 - 1. The Owner requires the Contractor to implement practices and procedures to meet the project's environmental performance goals, which include achieving LEED version 4 **Certified** level Certification. Specific project goals that may impact this area of work include: use of recycled-content materials; use of locally-manufactured materials; use of low-emitting materials; construction waste recycling; and the implementation of a construction indoor air quality management plan. The Contractor shall ensure that the requirements related to these goals, as defined in the Articles below, are implemented to the fullest extent. Substitutions, or other changes to the work proposed by the Contractor or their Subcontractors, shall not be allowed if such changes compromise the aforementioned environmental goals and LEED certification.

1.2 SUMMARY

- A. This Section includes the following:
 - 1. Single-duct, pressure independent air terminal units.
- B. Section 01 81 13 "Sustainable Design Requirements – LEED v4 for Building Design & Construction – New Construction" for sustainable design requirements and detailed sustainable design submittal requirements.
- C. Section 01 74 19 "Construction and Demolition Waste Management and Disposal" for disposal of construction, demolition and packaging waste disposal requirements.

1.3 SUBMITTALS

- A. Product Data: For each type of product indicated, include rated capacities, furnished specialties, sound-power ratings, and accessories.
- B. Shop Drawings: Detail equipment assemblies and indicate dimensions, required clearances, method of field assembly, components, and location and size of each field connection.
 - 1. Include a schedule showing unique model designation, room location, model number, size, and accessories furnished.
 - 2. Wiring Diagrams: Power, signal, and control wiring.
- C. Coordination Drawings: Reflected ceiling plans, drawn to scale, on which the following items are shown and coordinated with each other, based on input from installers of the items involved:
 - 1. Ceiling suspension assembly members.

2. Method of attaching hangers to building structure.
 3. Size and location of initial access modules for acoustical tile.
 4. Ceiling-mounted items including lighting fixtures, diffusers, grilles, speakers, sprinklers, access panels, and special moldings.
- D. Operation and Maintenance Data: For air terminal units to include in emergency, operation, and maintenance manuals. In addition to items specified in Division 01 Section "Operation and Maintenance Data" include the following:
1. Instructions for resetting minimum and maximum air volumes.
 2. Instructions for adjusting software set points.

1.4 QUALITY ASSURANCE

- A. Product Options: Drawings indicate size, profiles, and dimensional requirements of air terminal units and are based on the specific system indicated. Refer to Division 01 Section "Product Requirements."
- B. Electrical Components, Devices, and Accessories: Listed and labeled as defined in NFPA 70, Article 100, by a testing agency acceptable to authorities having jurisdiction, and marked for intended use.
- C. NFPA Compliance: Install air terminal units according to NFPA 90A, "Standard for the Installation of Air Conditioning and Ventilating Systems."

1.5 COORDINATION

- A. Coordinate layout and installation of air terminal units and suspension system with other construction that penetrates ceilings or is supported by them, including light fixtures, HVAC equipment, fire-suppression system, and partition assemblies.

PART 2 - PRODUCTS

2.1 MANUFACTURERS

- A. In articles that follow where manufacturers are listed, the following requirements apply to product selection:
 1. Manufacturers: Subject to compliance with requirements, provide products by one of the manufacturers specified.

2.2 SINGLE-DUCT PRESSURE INDEPENDENT AIR TERMINAL UNITS

- A. Manufacturers:
 1. Titus.
 2. Trane.
- B. Configuration: Volume-damper assembly inside unit casing with control components located inside a protective metal shroud.
- C. Casing: Solid double wall metal liner
 1. Casing Lining: 1-inch- thick fiberglass insulation with an R-value of 4.1.
 2. Air Inlet: Round stub connection or S-slip and drive connections for duct attachment.
 3. Air Outlet: S-slip and drive connections.
 4. Access: Removable panels for access to dampers and other parts requiring service, adjustment, or maintenance; with airtight gasket. Provide access

panel upstream of heating coil for cleaning. Gasketed access panel shall have cam latches for access.

- D. Regulator Assembly: Extruded-aluminum or galvanized-steel components; key damper blades onto shaft with nylon-fitted pivot points located inside unit casing.
 - 1. Automatic Flow-Control Assembly: Combined spring rates shall be matched for each volume-regulator size with machined dashpot for stable operation.
 - 2. Factory-calibrated and field-adjustable assembly with shaft extension for connection to externally mounted control actuator.
- E. Volume Damper: Galvanized steel with peripheral gasket and self-lubricating bearings.
 - 1. Maximum Damper Leakage: ARI 880 rated, 2 percent of nominal airflow at 3-inch wg inlet static pressure.
- F. Attenuator Section: 0.034-inch steel sheet metal.
 - 1. Lining: 1-inch- (25-mm-) thick, non-porous, sealed liner which complies with UL 181 and NFPA 90A. Insulation shall be 4 pound density secured with adhesive. Liner shall be equal to Titus Steri-Loc.
 - 2. All sound attenuators serving boxes that are part of the operating room systems shall be special packless type and shall be as specified under Section 230549 including special cleaning and protection.
- G. Hot-Water Heating Coil: Copper tube, mechanically expanded into aluminum-plate fins; leak tested underwater to 200 psig (1380 kPa); and factory installed.
- H. DDC Controls: Single-package unitary controller and actuator specified in Division 23 Section "Instrumentation and Control for HVAC." Controller and actuator to be shipped by DDC contractor for factory installation.

2.3 FAN-POWERED AIR TERMINAL UNITS

- A. Manufacturers:
 - 1. Titus.
 - 2. Price Industries.
 - 3. Trane.
- B. Configuration: Volume-damper assembly and fan in series arrangement inside unit casing with control components inside a protective metal shroud.
- C. Casing: 0.034-inch (0.85-mm) steel, solid double wall
 - 1. Casing Lining: 1-inch- (25-mm-) thick, coated, fibrous-glass duct liner complying with ASTM C 1071; secured with adhesive with an R-value of 4.1
 - 2. Air Inlets: Round stub connections or S-slip and drive connections for duct attachment.
 - 3. Air Outlet: S-slip and drive connections.
 - 4. Access: Removable panels for access to dampers and other parts requiring service, adjustment, or maintenance; with airtight gasket and quarter-turn latches. Provide access panel upstream of heating coil for cleaning. Gasketed access panel shall have cam latches for access.
- D. Volume Damper: Galvanized steel with peripheral gasket and self-lubricating bearings.

1. Maximum Damper Leakage: AHRI 880 rated, 2 percent of nominal airflow at 3-inch wg (750-Pa) inlet static pressure.
 2. Damper Position: Normally open
- E. Fan Section: Galvanized-steel plenum, with direct-drive, forward-curved fan with backdraft damper.
1. Motor: Electrically Commutated Motor (ECM): Comply with requirements in Division 23 Section "Common Motor Requirements for HVAC Equipment."
 - a. Speed Control: The speed controller shall allow for manual dial motor speed adjustments or a 2-10 VDC signal for variable speed control. The ECM shall be factory programmed with a constant torque to vary the airflow with fluctuations in the external static pressure.
 - b. Fan-Motor Assembly Isolation: Rubber isolators.
 2. Air Filter: Not required. Provide blank off sheet metal section for bypass air intake. Unit shall run in primary only mode.
- F. Attenuator Section: 0.034-inch (0.85-mm) steel sheet metal.
1. Provide with an AHRI certified assembly discharge silencer complete with an acoustically tuned silencer
 2. The silencer media shall be fiberglass
 3. The silencer shall be lined with the following media protection;
 - a. Polymer liner
- G. Hot-Water Heating Coil: Copper tube, mechanically expanded into aluminum-plate fins; leak tested underwater to 200 psig (1380 kPa); and factory installed.
- H. DDC Controls: Single-package unitary controller and actuator specified in Division 23 Section "Instrumentation and Control for HVAC." Controller and actuator to be shipped by DDC contractor for factory installation.
- 2.4 SOURCE QUALITY CONTROL
- A. Identification: Label each air terminal unit with plan number, nominal airflow, maximum and minimum factory-set airflows, coil type, and ARI certification seal.
 - B. Verification of Performance: Rate air terminal units according to ARI 880.

PART 3 - EXECUTION

3.1 INSTALLATION

- A. Install air terminal units level and plumb. Maintain sufficient clearance for normal service and maintenance.

3.2 CONNECTIONS

- A. Piping installation requirements are specified in other Division 23 Sections. Drawings indicate general arrangement of piping, fittings, and specialties.
- B. Install piping adjacent to air terminal units to allow service and maintenance.

- C. Hot-Water Piping: In addition to requirements in Division 23 Section "Hydronic Piping," connect heating coils to supply with shutoff valve, strainer, control valve, and union or flange; and to return with balancing valve and union or flange.
- D. Connect ducts to air terminal units according to Division 23 Section "Sheet Metal Work".
- E. Connect wiring according to Division 26 Section "Low-Voltage Electrical Power Conductors and Cables."
- F. Tighten electrical connectors and terminals according to manufacturer's published torque-tightening values. If manufacturer's torque values are not indicated, use those specified in UL 486A and UL 486B.

3.3 FIELD QUALITY CONTROL

- A. Perform the following field tests and inspections and prepare test reports:
 - 1. After installing air terminal units and after electrical circuitry has been energized, test for compliance with requirements.
 - 2. Leak Test: After installation, fill water coils and test for leaks. Repair leaks and retest until no leaks exist.
 - 3. Operational Test: After electrical circuitry has been energized, start units to confirm proper motor rotation and unit operation.
 - 4. Test and adjust controls and safeties. Replace damaged and malfunctioning controls and equipment.
- B. Remove and replace malfunctioning units and retest as specified above.

END OF SECTION

Maine Medical Center
Portland, Maine
Construction Documents - East Tower 6 & 7 Addition

PERKINS+WILL
Project Number: 152181.000
26 January 2018

Maine Medical Center
Portland, Maine
Construction Documents - East Tower 6 & 7 Addition

PERKINS+WILL
Project Number: 152181.000
26 January 2018

This page is intentionally left blank.

SECTION 23 37 13

DIFFUSERS, REGISTERS, AND GRILLES

PART 1 - GENERAL

1.1 RELATED DOCUMENTS

- A. Drawings and general provisions of the Contract, including General and Supplementary Conditions and Division 01 Specification Sections, apply to this Section.
- B. Section 01 81 13 "Sustainable Design Requirements – LEED v4 for Building Design & Construction – New Construction" for sustainable design requirements and detailed sustainable design submittal requirements.
- C. Section 01 74 19 "Construction and Demolition Waste Management and Disposal" for disposal of construction, demolition and packaging waste disposal requirements.

1.2 SUMMARY

- A. Section Includes:
 - 1. Rectangular and square ceiling diffusers.
 - 2. Linear bar diffusers.
 - 3. Adjustable bar registers and grilles.
 - 4. Fixed face registers and grilles.
 - 5. Linear bar grilles.
 - 6. Operating Room Diffusors
 - 7. Operating Room Ceiling Grid
- B. Related Sections:
 - 1. Division 08 Section "Louvers and Vents" for fixed and adjustable louvers and wall vents, whether or not they are connected to ducts.
 - 2. Division 23 Section "Air Duct Accessories" for fire and smoke dampers and volume-control dampers not integral to diffusers, registers, and grilles.
- C. Sustainable Building Requirements:
 - 1. The Owner requires the Contractor to implement practices and procedures to meet the project's environmental performance goals, which include achieving LEED version 4 **Certified** level Certification. Specific project goals that may impact this area of work include: use of recycled-content materials; use of locally-manufactured materials; use of low-emitting materials; construction waste recycling; and the implementation of a construction indoor air quality management plan. The Contractor shall ensure that the requirements related to these goals, as defined in the Articles below, are implemented to the fullest extent. Substitutions, or other changes to the work proposed by the Contractor or their Subcontractors, shall not be allowed if such changes compromise the aforementioned environmental goals and LEED certification.

1.3 SUBMITTALS

- A. Product Data: For each type of product indicated, include the following:
 - 1. Data Sheet: Indicate materials of construction, finish, and mounting details; and performance data including throw and drop, static-pressure drop, and noise ratings.
 - 2. Diffuser, Register, and Grille Schedule: Indicate drawing designation, room location, quantity, model number, size, and accessories furnished.
- B. Samples for Initial Selection: For diffusers, registers, and grilles with factory-applied color finishes.
- C. Samples for Verification: For diffusers, registers, and grilles, in manufacturer's standard sizes to verify color selected.
- D. Coordination Drawings: Reflected ceiling plans, drawn to scale, on which the following items are shown and coordinated with each other, using input from Installers of the items involved:
 - 1. Ceiling suspension assembly members.
 - 2. Method of attaching hangers to building structure.
 - 3. Size and location of initial access modules for acoustical tile.
 - 4. Ceiling-mounted items including lighting fixtures, diffusers, grilles, speakers, sprinklers, access panels, and special moldings.
 - 5. Duct access panels.
- E. Source quality-control reports.

PART 2 - PRODUCTS

2.1 CEILING DIFFUSERS

- A. Rectangular and Square Ceiling Diffusers:
 - 1. Manufacturers: Subject to compliance with requirements, provide products by one of the following:
 - a. Tuttle & Bailey-Agitair Type RC.
 - b. Titus Type TDX.
 - c. Anemostat Type D.
 - d. Price SMX.
 - 2. Devices shall be specifically designed for variable-air-volume flows with internal directional induction vanes.
 - 3. Material: Steel.
 - 4. Finish: Baked enamel, white.
 - 5. Face Size: 24 by 24 inches.
 - 6. Mounting: T-bar and plaster.
 - 7. Pattern: Refer to drawings.
 - 8. Accessories:
 - a. Minimum 3"high plenum (not including duct collar) square to round adapter installed at the factory. Adapter to fit on inside of diffuser neck to minimize leakage.

2.2 LINEAR SLOT OUTLETS

- A. Linear Diffuser:

1. Manufacturers: Subject to compliance with requirements, provide products by one of the following:
 - a. Tuttle & Bailey
 - b. Anemostat Products; a Mestek company.
 - c. Titus.
 - d. Price.
 2. Devices shall be specifically designed for variable-air-volume flows.
 3. Material: Extruded aluminum.
 4. Finish: Baked enamel, white.
 5. The diffuser shall be designed so that the air will be discharged at a uniform velocity across the entire length of the unit. The air streams shall be discharged at counter angles parallel to the diffuser mounting surface by extruded aluminum fixed louvers providing one or two way discharge patterns to create induction of room air within the primary air stream to achieve rapid mixing of primary and room air. The diffuser efficiency must be such that the initial temperature differential shall be reduced by 50% at a distance one foot from the point of discharge. Slotted outlets of the grille type lacking diffusion vanes and mixing characteristics shall not be accepted.
 6. Diffusers shall be equipped with matching extruded aluminum plaster frames or to match ceiling types. Frames shall be equipped with slots to accept the coil mounting springs mounted on the diffuser for positive mounting within the frame. Visible fasteners shall not be accepted.
 7. Mounting: Concealed, Spring clip.
 8. Accessories: Plaster frame, Directional vanes, Alignment pins, Core clips and Blank-off strips where indicated.
 9. Diffusers in curved walls shall be constructed of lengths that respect the curved surface (maximum 3'-0") so the diffuser does not need to be curved. Refer to drawings.
- B. Ceiling-Integral Continuous Diffuser:
1. Manufacturers: Subject to compliance with requirements, provide products by one of the following:
 - a. Anemostat Products; a Mestek company.
 - b. Titus.
 - c. Price.
 - d. Tuttle and Bailey
 2. Slot Width: shall be as schedule.
 3. Section Length: shall be as indicted on the drawing.
 4. Straight and curved sections as required to accommodate layout.
 5. Mitered tees and corners.
 6. Pattern Controllers: 24 inches o.c.
 7. Material: Aluminum, extruded, heavy wall.
 8. Finishes:
 - a. Exterior: Standard white baked enamel.
 - b. Interior: Standard black.
 9. Mounting: Ceiling and Sidewall.
 10. Plenum: all Insulated and vapor proof.
 11. Other Features:
 - a. Painted interior.
 - b. Blank-offs.

2.3 REGISTERS AND GRILLES

A. Adjustable Bar Register:

1. Manufacturers: Subject to compliance with requirements, provide products by one of the following:
 - a. Anemostat Products; a Mestek company.
 - b. Titus.
 - c. Tuttle & Bailey
 - d. Price.
 - e. Krueger.
2. Material: Steel.
3. Finish: Baked enamel, white.
4. Face Blade Arrangement: Horizontal.
5. Core Construction: Integral.
6. Rear-Blade Arrangement: Vertical.
7. Frame: 1 inch wide.
8. Mounting: Concealed.

B. Adjustable Bar Grille:

1. Manufacturers: Subject to compliance with requirements, provide products by one of the following:
 - a. Anemostat Products; a Mestek company.
 - b. Titus.
 - c. Tuttle & Bailey.
 - d. Price.
 - e. Krueger.
2. Material: Steel.
3. Finish: Baked enamel, white.
4. Face Blade Arrangement: Horizontal.
5. Core Construction: Integral.
6. Rear-Blade Arrangement: Vertical.
7. Frame: 1 inch (25 mm) wide.
8. Mounting: Concealed.

2.4 OPERATING ROOM DIFFUSER:

A. Operating Room Diffuser:

1. Supply and install air systems in each operating room of the sizes and capacities as indicated on the drawings or diffuser schedule. Equivalent manufactures shall include:
 - a. Tuttle and Bailey
 - b. Titus
 - c. Krueger
 - d. Price
2. Each operating room air system shall consist of modular slot diffusers which shall provide a protective air curtain around the operating area and laminar flow diffusers which shall provide a supply of sterile air over the operating table area
3. The slot diffuser and laminar flow diffuser shall be of aluminum construction
4. The slot diffusers shall consist of a .064" (2) aluminum plenum with continuous welded joints and radiused corners to facilitate cleaning, extruded aluminum frames, formed aluminum diffuser face with two slots and fixed pattern deflectors. Plenums shall have formed aluminum inlet collars

complete with dampers, removable from plenum face. The removable dampers shall be opposed blade type of stainless steel construction. Damper shall be adjusted without removing face of HORD. The diffuser face shall be attached by 90° quick-release fasteners and safety cable for easy removal and replacement. Entire plenum and diffusers shall have a B11 Sterile White - Thermal Setting finish which meets special requirements for hospital use and will be subjected to regular cleaning with high concentration cleaning solutions and agents for sterilization purposes

5. The laminar flow diffusers shall have components of aluminum and plated steel to inhibit corrosion. The perforated face plate, perforated damper deflector using interior baffles and diffuser back pan plenum assembly shall be of 0.040 (1) aluminum. The volume control damper shall be a steel construction full flow type damper. The perforated face plate shall open easily with ¼ turn fasteners and safety cable for damper adjustment and cleaning. Diffusers shall have a B11 Sterile White - Thermal Setting finish which will withstand cleaning with high concentration cleaning solutions and agents

B. Return Grille

1. The hospital operating room return grilles shall be of stainless steel construction. The core of the return grille will consist of 45° louvres, 0.75" (19) on centre. The grille border shall have a #4 finish. The grille shall use 90° quick-release fasteners to mount to a separate stainless steel wall mounting frame, provided with the unit, thereby allowing easy removal for cleaning.

2.5 OPERATING ROOM CEILINGS

- A. The operating room air diffuser manufacturer shall furnish extruded aluminum tee and angle frame ceiling suspension system to support air diffusers, fill-in panels and light fixtures. Tees should have a 1.5" face width and 1.563" overall height. Minimum wall thickness of tees shall be 0.125" with a minimum weight of 0.45 lbs. per linear ft (full tee). All tee and angle frame extrusions should include channels along the top of the stack to support hold-down clips for fill-in panels. Extrusions shall be fabricated using 100% pre-consumer recycled aluminum material. The manufacturer shall coordinate with the medical equipment supplier and other trades to insure fit and finish. The manufacturer shall provide detailed CAD drawings for approval prior to fabrication.
- B. The ceiling suspension system shall be factory heliarc welded in sub-assemblies not larger than 5' x 10', where framing sub-assemblies butt together for field assembly. The butting angles shall be half tees mechanically-fastened together with heavy duty bolts.
- C. All tees and angles shall be pre-punched on 4.85" centers for attachment to minimum 12 gauge pre-stressed suspending hanger wires on minimum 48" centers. Systems shall be designed to support 15 lbs/sq.ft when installed as per ASTM C636. Hangers are by others.
- D. Manufacturer shall furnish 0.125" thick closed-cell polyethylene gasket tape to be (factory) installed on the frame assembly to provide an airtight seal between the tees and diffusers, fill-in panels and/or light fixtures. Gasket shall also be field applied between framing sub-assemblies prior to field assembly. Infill panels shall be (Equal to Price SC Series lay-in type, 0.040" unperforated aluminum, or equal to

Price SPB Series perforated panel with border consisting of 0.040" perforated aluminum faceplate with 0.040" solid aluminum backing with B11 finish

1. Fill-in panels should be held down using factory supplied spring clips on all sides of the panel to seal against the closed-cell gasket. Manufacturer shall provide filler panels and access as required (provide a minimum of four access panels at corners of grid). Manufacturer shall coordinate tee and panel layout with medical equipment manufacturer
- E. The ceiling suspension system shall have a baked-on powder coat finish to match the laminar flow diffusers and fill-in panels. Paint finish must demonstrate no deterioration when tested in accordance with ASTM D1308 (covered spot & immersion) and ASTM D4752 (MEK double rub) paint durability tests.
- 2.6 SOURCE QUALITY CONTROL
- A. Verification of Performance: Rate diffusers, registers, and grilles according to ASHRAE 70, "Method of Testing for Rating the Performance of Air Outlets and Inlets."

PART 3 - EXECUTION

3.1 EXAMINATION

- A. Examine areas where diffusers, registers, and grilles are to be installed for compliance with requirements for installation tolerances and other conditions affecting performance of equipment.
- B. Proceed with installation only after unsatisfactory conditions have been corrected.

3.2 INSTALLATION

- A. Install diffusers, registers, and grilles level and plumb.
- B. Ceiling-Mounted Outlets and Inlets: Drawings indicate general arrangement of ducts, fittings, and accessories. Air outlet and inlet locations have been indicated to achieve design requirements for air volume, noise criteria, airflow pattern, throw, and pressure drop. Make final locations where indicated, as much as practical. For units installed in lay-in ceiling panels, locate units in the center of panel. Where architectural features or other items conflict with installation, notify Architect for a determination of final location.
- C. Install diffusers, registers, and grilles with airtight connections to ducts and to allow service and maintenance of dampers, air extractors, and fire dampers.
- D. Noise level at noted capacities shall not exceed criteria specified in Section NOISE CONTROL. Diffusers shall be suitable for operation at 5 percent excess and 25 percent less than noted capacity. Provide blanking for proper coverage and blow without producing objectionable noise or air motion at occupied level. Finish shall match color sample as approved:
- E. Linear diffusers: Frame types shall mate with ceilings. Provide means to neatly butt and align units to give continuous appearance without butting flanges. No screw holes or welded corners visible on diffusers or frames will be permitted. Air volume shall be adjustable through air supply face without requiring removal of

face panel. Provide blanked sections for inactive lengths. Provide plaster frames and opposed blade volume dampers with remote cable operators where noted. Refer to Architectural Drawings for mounting details and overall lengths. Finish shall match color sample as approved:

- F. Install all fire rated diffusers in compliance with NFPA and UL listed installation instructions.

3.3 ADJUSTING

- A. After installation, adjust diffusers, registers, and grilles to air patterns indicated, or as directed, before starting air balancing.

3.4 Operating Room Ceiling Installation

- A. Install all components in accordance with the manufactures' instructions in accordance to ASTM C 636.
- B. Main grid members are to be suspended on pre-stressed hanger wire at 4' (1200 mm) centers. Minimum gauge for the hanger wire shall be 12 gauge.
- C. Maximum allowable deflection shall not exceed L/360.
- D. Install ceilings to heights indicated on eh plans and specifications to a tolerance of 1/8" in 12'-0" (3.2mm in 3660 mm).

END OF SECTION

This page is intentionally left blank.

SECTION 23 57 00

HEAT EXCHANGERS FOR HVAC

PART 1 - GENERAL

1.1 RELATED DOCUMENTS

- A. Drawings and general provisions of the Contract, including General and Supplementary Conditions and Division 01 Specification Sections, apply to this Section.
- B. Section 01 81 13 "Sustainable Design Requirements – LEED v4 for Building Design & Construction – New Construction" for sustainable design requirements and detailed sustainable design submittal requirements.
- C. Section 01 74 19 "Construction and Demolition Waste Management and Disposal" for disposal of construction, demolition and packaging waste disposal requirements.

1.2 SUMMARY

- A. This Section includes shell-and-tube heat exchangers.
- B. Sustainable Building Requirements:
 - 1. The Owner requires the Contractor to implement practices and procedures to meet the project's environmental performance goals, which include achieving LEED version 4 **Certified** level Certification. Specific project goals that may impact this area of work include: use of recycled-content materials; use of locally-manufactured materials; use of low-emitting materials; construction waste recycling; and the implementation of a construction indoor air quality management plan. The Contractor shall ensure that the requirements related to these goals, as defined in the Articles below, are implemented to the fullest extent. Substitutions, or other changes to the work proposed by the Contractor or their Subcontractors, shall not be allowed if such changes compromise the aforementioned environmental goals and LEED certification.

1.3 SUBMITTALS

- A. Product Data: Include rated capacities, operating characteristics, furnished specialties, and accessories.
- B. Shop Drawings: Signed and sealed by a qualified professional engineer. Detail equipment assemblies and indicate dimensions, weights, loads, required clearances, method of field assembly, components, and location and size of each field connection.
 - 1. Design Calculations: Calculate requirements for selecting seismic restraints and for designing bases.
 - 2. Base Details: Detail fabrication including anchorages and attachments to structure and to supported equipment.

- C. Coordination Drawings: Equipment room, drawn to scale, on which the following items are shown and coordinated with each other, based on input from installers of the items involved:
 - 1. Tube-removal space.
 - 2. Structural members to which heat exchangers will be attached.
 - D. Manufacturer Seismic Qualification Certification: Submit certification that heat exchanger, accessories, and components will withstand seismic forces defined in Division 23 Section "Vibration and Seismic Controls for HVAC Piping and Equipment." Include the following:
 - 1. Basis for Certification: Indicate whether withstand certification is based on actual test of assembled components or on calculation.
 - a. The term "withstand" means "the unit will remain in place without separation of any parts from the device when subjected to the seismic forces specified."
 - b. The term "withstand" means "the unit will remain in place without separation of any parts from the device when subjected to the seismic forces specified and the unit will be fully operational after the seismic event."
 - 2. Dimensioned Outline Drawings of Equipment Unit: Identify center of gravity and locate and describe mounting and anchorage provisions.
 - 3. Detailed description of equipment anchorage devices on which the certification is based and their installation requirements.
 - E. Operation and Maintenance Data: For heat exchangers to include in emergency, operation, and maintenance manuals.
- 1.4 QUALITY ASSURANCE
- A. Product Options: Drawings indicate size, profiles, performance, and dimensional requirements of heat exchangers and are based on the specific equipment indicated. Refer to Division 01 Section "Product Requirements."
 - B. ASME Compliance: Fabricate and label heat exchangers to comply with ASME Boiler and Pressure Vessel Code: Section VIII, "Pressure Vessels," Division 1.
 - C. Registration: Fabricate and label shell-and-tube heat exchangers to comply with the Tubular Exchanger Manufacturers Association's standards.

PART 2 - PRODUCTS

2.1 MANUFACTURERS

- A. In other Part 2 articles where titles below introduce lists, the following requirements apply to product selection:
 - 1. Manufacturers: Subject to compliance with requirements, provide products by one of the manufacturers specified.

2.2 SHELL-AND-TUBE HEAT EXCHANGERS

- A. Manufacturers:
 - 1. Armstrong Pumps, Inc.
 - 2. ITT Industries; Bell & Gossett.
 - 3. Taco, Inc.

4. Patterson Kelley
- B. Configuration: U-tube with removable bundle.
- C. Shell Materials: Steel Head:
 1. Materials: Cast iron
 2. Flanged and bolted to shell.
- D. Tube:
 1. Seamless copper tubes.
 2. Tube diameter is determined by manufacturer based on service.
- E. Tubesheet Materials: Steel tubesheets.
- F. Baffles: Steel.
- G. Piping Connections:
 1. Shell: Flanged inlet and threaded outlet fluid connections, threaded drain, and vent connections.
 2. Head: Flanged inlet and outlet fluid connections.
- H. Support Saddles:
 1. Fabricated of material similar to shell.
 2. Foot mount with provision for anchoring to support.
 3. Fabricate attachment of saddle supports to pressure vessel with reinforcement strong enough to resist heat-exchanger movement during a seismic event when heat-exchanger saddles are anchored to building structure.

PART 3 - EXECUTION

3.1 EXAMINATION

- A. Examine areas for compliance with requirements for installation tolerances and for structural rigidity, strength, anchors, and other conditions affecting performance of heat exchangers.
 1. Proceed with installation only after unsatisfactory conditions have been corrected.

3.2 HEAT-EXCHANGER INSTALLATION

- A. Install shell-and-tube heat exchangers on saddle supports.
- B. Install shell-and-tube heat exchangers on concrete base. Concrete base is specified in Division 23 Section "Common Work Results for HVAC," and concrete materials and installation requirements are specified in Division 03.
- C. Concrete Bases: Anchor heat exchanger to concrete base.
 1. Install dowel rods to connect concrete base to concrete floor. Unless otherwise indicated, install dowel rods on 18-inch (450-mm) centers around full perimeter of base.
 2. For supported equipment, install epoxy-coated anchor bolts that extend through concrete base and anchor into structural concrete floor.
 3. Place and secure anchorage devices. Use setting drawings, templates, diagrams, instructions, and directions furnished with items to be embedded.

4. Install anchor bolts to elevations required for proper attachment to supported equipment.
5. Cast-in-place concrete materials and placement requirements are specified in Division 03.

3.3 CONNECTIONS

- A. Piping installation requirements are specified in other Division 23 Sections. Drawings indicate general arrangement of piping, fittings, and specialties.
- B. Maintain manufacturer's recommended clearances for service and maintenance. Install piping connections to allow service and maintenance of heat exchangers.
- C. Install shutoff valves at heat-exchanger inlet and outlet connections.
- D. Install relief valves on heat-exchanger heated-fluid connection and install pipe relief valves, full size of valve connection, to floor drain.
- E. Install vacuum breaker at heat-exchanger steam inlet connection.
- F. Install hose end valve to drain shell.

3.4 FIELD QUALITY CONTROL

- A. Test and adjust controls and safeties. Replace damaged and malfunctioning controls and equipment.

3.5 CLEANING

- A. After completing system installation, including outlet fitting and devices, inspect exposed finish. Remove burrs, dirt, and construction debris and repair damaged finishes.

3.6 DEMONSTRATION

- A. Train Owner's maintenance personnel to adjust, operate, and maintain heat exchangers. Refer to Division 01 Section "Demonstration and Training."

END OF SECTION

SECTION 23 73 14

CUSTOM PACKAGED CENTRAL STATION AIR HANDLING UNITS

PART 1 - GENERAL

1.1 SUMMARY

A. Sustainable Building Requirements:

1. The Owner requires the Contractor to implement practices and procedures to meet the project's environmental performance goals, which include achieving LEED version 4 **Certified** level Certification. Specific project goals that may impact this area of work include: use of recycled-content materials; use of locally-manufactured materials; use of low-emitting materials; construction waste recycling; and the implementation of a construction indoor air quality management plan. The Contractor shall ensure that the requirements related to these goals, as defined in the Articles below, are implemented to the fullest extent. Substitutions, or other changes to the work proposed by the Contractor or their Subcontractors, shall not be allowed if such changes compromise the aforementioned environmental goals and LEED certification.

1.2 RELATED SECTIONS

- A. Section 01 81 13 "Sustainable Design Requirements – LEED v4 for Building Design & Construction – New Construction" for sustainable design requirements and detailed sustainable design submittal requirements.
- B. Section 01 74 19 "Construction and Demolition Waste Management and Disposal" for disposal of construction, demolition and packaging waste disposal requirements.

1.3 DESCRIPTION:

- A. This section of the work includes the design, fabrication, testing, cleaning and packaging, shipment and final assembly of custom built-up air handling units by the unit manufacturer in complete accordance with the following specification.
- B. The details outlined and component manufacturers named in this specification may not be deviated from in the air handling unit manufacturer's preparation of the bid, even where techniques are required which are not considered standard by the manufacturer. The construction as described in this specification is considered essential, and any deviation from this specification must be specifically identified and bid as a Voluntary Alternate (add or deduct), but only after complying with the specification defined as the Base Bid.

1.4 SUBMITTALS:

- A. WITH THE QUOTATION: Provide the following detailed information on the equipment proposed Unit manufacturer shall itemize all deviations from the specified requirements. If not so indicated, unit manufacturer will be required to furnish at no cost to the owner:

1. Information requested in the RFQ, including equipment data sheets, schedules and sketches.
2. Equipment drawings showing dimensions, weights (shipping & operating), configuration, major component locations, access door locations, duct connection sizes and locations, and shipping split locations.
3. Fan manufacturer and performance curves with the operating points clearly indicated. Motor sizes and types.
4. Coil selections with sizes, rows, fin spacing, face velocities, temperatures, flow rates, pressure drops, & connection sizes.
5. Proposed filters indicating size, efficiency, and pressure drop.
6. Materials of construction for housing and major components.
7. Airborne and transmitted sound power levels by octave band.

AFTER PURCHASE: Make submittals in accordance with requirements of conditions of purchase. Submittals shall show Buyer's purchase order number, equipment number and project number. Information shall include, as applicable, but not be limited to the following:

8. Information submitted with quotation, revised and expanded as required.
 9. If applicable) Electrical data, wiring diagrams, and accessory panel layouts. Clearly differentiate between portions of wiring that are factory-installed and portions to be field-installed.
 10. If applicable) Factory testing procedures for review and acceptance.
- B. AFTER RECEIPT OF APPROVED DRAWINGS: Submit manuals with detailed description of installation, operation, and maintenance, including the following:
1. All approved "Certified for Construction" drawings.
 2. Written recommendations for field storage, both indoors and outdoors.
 3. Installation requirements including assembly instructions, lifting requirements and adjustments.
 4. Manufacturer's literature describing each piece of equipment furnished including operation instructions including step by step preparation of starting, shutdown, and draining and maintenance instructions including lubrication.

1.5 OPERATION AND MAINTENANCE DATA

- A. Submit operation and maintenance data
- B. Include instructions for lubrication, filter replacement, motor and drive replacement, spare parts lists, and wiring diagrams.

1.6 QUALIFICATIONS

- A. Manufacturer: Company specializing in manufacturing the Products specified in this section with minimum five years documented experience, who issues complete catalog data on total product.

1.7 DELIVERY, STORAGE, AND HANDLING

- A. Deliver, store, protect and handle products to site under provisions of Division 01 and Section 230001.
- B. Accept products on site in factory-fabricated protective containers, with factory-installed shipping skids. Inspect for damage.

- C. Store in clean dry place and protect from weather and construction traffic. Handle carefully to avoid damage to components, enclosures, and finish.
- D. The entire unit shall be sealed with wrap and have water absorption desiccant packs in each section to eliminate moisture during shipping.

1.8 ENVIRONMENTAL REQUIREMENTS

- A. Do not operate units for any purpose, temporary or permanent, until ductwork is clean, filters are in place, bearings lubricated, and fan has been test run under observation.

1.9 EXTRA STOCK

- A. Provide one complete set of extra disposable filters per air handling unit.

PART 2 - PRODUCTS

2.1 CUSTOM AIR HANDLING UNITS MANUFACTURERS

- A. Manufacturers: Units shall be as manufactured by Trane Custom, Ventrol, or York Custom.

2.2 CUSTOM AIR HANDLING UNIT

- A. Custom built-up units shall be of the configuration, capacity and style as indicated on the drawings and Equipment Schedule and as specified herein. Through properly designed access; ease of maintenance, removability of components, and unit serviceability shall be assured.

- B. General:

1. The unit manufacturer shall be responsible for provisions of fans, dampers and all other unit and plenum components as specified in this section or other sections of this division and performance characteristics as shown in schedules or on drawings. The unit manufacturer shall provide all field labor for assembly of enclosure and components.
2. Unit shall be factory-fabricated for shipping and field assembly by experienced manufacturer of large custom air handling units, that maintains engineering and production staff.
 - a. Provide proof of credentials of manufacturer's staff as required by Owner and Architect.
3. Shop drawings shall be subject to approval of the Owner and Architect.
4. Certify conformance with performance requirements specified and shown on Drawings.
5. Provide necessary appurtenances to perform as specified, whether or not expressly required by Contract Documents mentioned herein in conformance with good trade practice, as determined by Architect.
6. Seal any casing penetrations made in field for piping, conduit, tubing and equipment installed under other sections. Manufacturer shall supply contractor with details for sealing casing. Manufacturer's field service representative shall inspect and approve all casing penetrations

- C. Testing:

1. Unit manufacturer shall provide (at no cost to owner) factory witness performance test for 4 people which includes contractor, engineer, and (2) owners.
2. Test to ensure structural integrity, design suitability under simulated operating conditions, systems operation and minimum vibration levels as specified. Certify that unit complies with design intent and Contract Documents.
3. Manufacturer shall be responsible for correcting any operating deficiencies found during the unit startup after installation.
4. Prior to shipping the following tests shall be performed:
 - a. Pressure test water coils if coil manufacturer has not already performed pressure test, and piping.
 - b. Energize electrical devices to ensure operational integrity prior to shipment. Replace non-functioning items.
 - c. Submit housing panel acoustical, structural and physical properties performance test data before shipment from independently certified test laboratory.
 - d. Performance Test:
 - 1) Perform a unit performance test in the factory. The performance test shall be done to determine unit flow rate, total static pressure across the fan, external static pressure available to overcome system losses, fan speed and input power to the fans. Filter losses shall be simulated to provide average filter loss [1/2(clean & dirty)]. Test results shall confirm the unit is able to produce the required CFM at the listed external static pressure drop on the drawing schedules. Fan brake horsepower shall not be greater than design power by more than 5 percent
 - 2) Unit Air Leakage Rate: Perform unit leak pressure test to meet air leakage rates not to exceed the following values at 1½ times the design static pressure (not to exceed 8 in. w.g.) Manufacturer shall be responsible for any corrections required to meet test criteria. Leak test shall be performed before any ductwork is connected. Factory to provide blank off of openings
 - a) ½ of 1% of the Design Airflow
5. Provide the following field tests after unit assembly:
 - a. Unit operation and vibration analysis. Operate fans at design RPM, set fan drive and conduct complete vibration spectrum as specified. Fan, motor, drive and base assembly, vibration shall be brought to within specified levels. Check motor and drive vibration with fan as a completed assembly. Vibration levels shall be measured in velocity (in/sec peak) in the horizontal, axial and vertical direction on the housing of both fan bearings while tuned to the fan running speed. A second reading based on the overall shall be made as a check on other possible vibration sources other than balance. The following is the acceptance criteria in velocity (in/sec peak):

ISOLATOR SUPPORTS

Direction	Radial	Axial
Filtered	0.16	0.32
Overall	0.40	0.40

- D. Unit shall comprise of, but not limited to, sections shown on drawings and the following list:
1. Double wall aluminum outer cabinet. Construction shall employ 'no through metal' design.
 2. Outside air intake section with minimum and economizer outside air dampers.
 3. Pre-Filter
 4. Final Filter
 5. Discharge Filters (Discharge HEPA)
 6. Air Blender (AHU-149 only)
 7. Steam preheat coil
 8. Chilled water cooling unit
 9. Humidifier
 10. Supply air fan section.
 11. UV Lights at Cooling Coil
 12. Discharge Air Plenum
 13. Outdoor air and supply air flow stations. Outdoor air flow station transducer shall be by until manufacturer. ATC shall provide supply fan transducers.
 14. Smoke Isolation Control dampers
 15. 24" high roof curb
- E. Provide safing between internal components and unit casing to prevent air bypass. Safing material shall match unit interior. All seams or voids between safing, components and unit casing shall be caulked and sealed airtight.
- F. Unit shall employ aluminum material wherever possible (panels, bases, supports, safing, etc).

2.3 AIR HANDLING UNIT BASE:

- A. The unit shall be constructed on an all aluminum structural base. The base shall be designed to distribute loads properly to a suitable mounting surface and be braced to support internal components without sagging, pulsating or oil canning. The base sections for the field fabricated units shall be provided as complete prefabricated sections for field joining.
- B. The entire unit base shall be fully welded and guaranteed waterproof; cooling coil condensate shall have a minimum 3" deep sump between structural members to serve as a drain pan to prevent building water damage from the unit. Sump to be 14 GA. stainless steel double-sloped towards units drains to positively remove condensate from the unit.
- C. The base floor shall be minimum 3/16" thick aluminum tread plate bonded to the base floor so that there is no thru metal. The base floor shall be designed for a minimum live load of 100 pounds per square foot throughout the unit. The base floor is to be supported with adequate stiffening members to prevent oil canning. Unit base shall be provided with aluminum longitudinal base channels that provide adequate support to limit floor deflection to 1/200th of the span. The floor surface shall not be the source of strength for component and service personnel weight. Floors shall have a 2" turned up lip to form a waterproof surface.
- D. The perimeter support members shall be a minimum of 6" welded structural member properly sized to support all major components and the housing during rigging, handling and operation of the unit.

- E. The underneath side of the base pan and base perimeter shall be insulated with minimum 2" thick 1.5-pcf high density polyisocyanurate foam insulation covered with a plastic sheet to form a vapor barrier. Vapor barrier material is to be continuous with no seams. Vapor barrier is then protected by a .04" thick aluminum sheet.
- F. Each section of the unit base shall contain a minimum 1" NPT drain to facilitate system washdown, maintenance and condensate removal. Areas in the base where potential standing water cannot be removed through drains or weep holes are not acceptable. Clean out drains shall be provided with removable caps of non-corrosive material.
- G. All equipment within air handling unit shall be provided with a minimum 2" high base to raise equipment off unit floor for housekeeping. Equipment mounted directly on unit floor is unacceptable.
- H. All unit base service openings shall be framed with a minimum 2" high water dam continuously welded to the floor.
- I. Fastening to floor plate or joining of unit sections to be accomplished by bolting through gasketed joints above the floor line. Fasteners which penetrate base floor plate are not acceptable.

2.4 AIR HANDLING UNIT CASING:

- A. Air handling unit casing shall be built up from the unit base with panels. The unit manufacturer shall be the manufacturer of the panel system. Panels shall be load bearing and capable of forming the enclosure without additional structural members. Panels shall be joined together with independent joining member and fastened with stainless steel fasteners.
- B. All panels shall be double wall all aluminum construction with minimum .040" aluminum exterior and .040" solid aluminum interior skin. Interior finish to be smooth mill finish, exterior to be a low reflective textured mill finished. Fan sections shall have acoustical absorptive panels. Acoustical absorptive panels shall not be used within 24" downstream of cooling coil. Each panel shall contain an integral frame or be properly supported by a structural framing system. Panel shall have continuous tight seal at the interior and exterior skins completely encapsulating the insulation.
 - 1. The minimum panel thickness shall be 4" thick with 3-pcf high density polyisocyanurate foam insulation. Core material shall comply with NFPA 90A requirements. Housing insulation shall have a "U" value greater than 0.07 BTU/Hr/Sq. Ft./ Deg. F.
- C. Thickness of the panel skin, core density, rib structural frame spacing shall be regulated to eliminate panel pulsation and restrict the maximum deflection to 1/200 of any span at design load of 1-1/2 times the design positive or negative pressure plus snow and wind loading. Casings shall be built to exceed AMCA Class "C" requirements.
- D. Casing system shall be guaranteed to assure the owner that system capacity, performance, and cleanliness standards specified are not compromised. All panel joints shall be sealed with gasket insulation. The gasketing shall be sealed to provide a full thermal and air leak free connection.

- E. All casing walls shall be of panel construction, including the fan discharge walls and mixing section walls
- F. Panel system shall incorporate an integral thermal break system throughout the unit such that there is no through metal path between the interior and exterior surface of the unit casing at all locations. Criteria to evaluate requirement for thermal break system shall be based upon scheduled unit performance and ambient conditions anticipated around the units. The preferred method for a thermal break shall consist of a minimum 1/2" structural epoxy bridge.
- G. Any equipment flashing, internal partitions or other attachments to the casing shall be made in such a way as to ensure a permanent leak-tight connection. Attachments that are bolted, screwed, or welded to or through the casing creating air bypass, air leakage or rust propagation areas are not acceptable.
- H. All ductwork penetrations through unit enclosure shall be provided with framed openings of size indicated on drawing. Openings to be provided with flanged duct connections of same material as casing interior extending a minimum of 4" from surface of unit casing. All piping and conduit penetrations shall be provided with sleeves sealed watertight to unit casing; pipe penetrations through the unit casings shall be by the unit manufacturer and be properly sealed prior to leaving the factory. Penetrations created by cutting through panels, compromising panel integrity, will not be acceptable. Penetrations made in the field shall be made under the supervision of the factory air handling units representative.
- I. Provide minimum 24" wide access doors for access to all internal components. Access doors shall be installed to open against the greatest pressure relative to air pressure on each side of access door
 - 1. Access doors shall be of the same construction as panels described above. Corners shall be seal welded for rigidity and air tightness. Mitered and caulked corners are unacceptable.
 - 2. The access doors shall be guaranteed tight closing by the means of two continuous separate gasket seals around the entire periphery of the door or panel set at a beveled 45° angle to assure a true perpendicular, non-shearing compression fit. Gasket material shall be UV-resistant, closed cell neoprene; gaskets shall be attached by adhesive and not be mechanically held in place. Single gasket seals or 90° gasket configurations will not be accepted.
 - 3. Each access door shall contain a thermopane tempered safety glass window (min. 10" square). Window assembly shall have a vacuum between panes to prevent condensation
 - 4. Each access door shall have a built-in static pressure probe port with cap plug for ease of pressure readings across various internal components. Provide minimum 1" dia. test ports with screwed caps on casing upstream and downstream of all coils and filters for pressure and temperature measurement.
 - 5. Each access door shall be mounted with stainless steel fully adjustable hinges, and shall have a least two (2) non-corrosive handles operable from either side. The door handles shall include self-locking nuts and stainless steel hardware to assure a long term proper door operation. Door handle striker plates shall be non-metallic high impact nylon with a notched "center position" to lock the handle in place. No moving parts shall contact the casing materials. Door tie backs shall be provided on all doors.

6. Removable access panels shall be provided as indicated on the drawings for service and maintenance. Access panels shall be of the same construction as panels described above. Removable access panels shall be designed and constructed such that removal and replacement may be accomplished without disturbing adjacent panels. Airtight integrity must be maintained.

2.5 AIR HANDLING UNIT ROOF CONSTRUCTION

- A. The roof section shall be 4" thick double wall
- B. The exterior skin of the roof shall be .04" thick aluminum, with .040" thick interior skin and internal channel supports
- C. 4" injectable foam insulation, with an R-value of 6.2 per inch, shall be used over the entire roof. Insulation shall meet all NFPA 90A requirements
- D. All panel seams shall be caulked with sealant.
- E. When a unit is split into sections, 2" x 1/4" perimeter companion channel with ridge cap shall be provided.

2.6 MOTORS

- A. REFER TO DIVISION 23 SECTION "COMMON MOTOR REQUIREMENTS FOR HVAC EQUIPMENT"

2.7 AIR HANDLING UNIT ELECTRICAL:

- A. Provide non-corroding vaportight LED light fixtures in each AHU compartment suitable for use in wet and damp locations.
 1. Lights shall have 120V cold weather ballasts with emergency backup power pack and shall comply with UL Standard #1570 and shall carry the UL label.
 2. Wiring shall be #12 copper type THHN in liquid tight conduct. Wire to cast watertight switch boxes with 60 minute timer switch, and trim plate on exterior of casing at each access door. Each timer switch shall energize lights in adjoining section of casing.
 3. Conduit and wiring to light fixtures and convenience outlets shall be brought back to a single NEMA 3R junction box at the exterior of the air handling unit for single source power connection. Provide circuiting per NEC (1600 watts max per circuit).
 4. Provide two (2) 1 1/4" liquid tight raceways along the entire top length of each unit section. Provide an internal junction box and conduit connection to allow for routing of temperature controls wiring and tubing through air handling unit.
- B. Provide duplex 120V, GFI, service outlet (outdoor use) in all accessible sections. Conduit and wiring to outlets shall be brought back to a single junction box (not same as lighting) for single source power connection.
- C. Extend motor leads to an external NEMA 1 service fused disconnect switch for each fan.
- D. The AHUs shall be wired 100% by manufacturer for connection by electrical contractor with separate main junction boxes for 120v and 460v power feeds for each VFD/fan motor. Electric work shall be in accordance with National Electrical Code and requirements of Section 26000.

2.8 PLUG/PLENUM FANS (SUPPLY AND RETURN)

- A. Fan shall be a single width, single inlet backward inclined centrifugal airfoil, direct driven plenum blowers as specified.
- B. The fans shall be of bolted and welded construction utilizing corrosion resistant fasteners. The inlet panel shall be constructed from minimum 10-gauge steel with a spun aluminum inlet cone. Bearings shall be supported on a welded assembly constructed of minimum ¼' x 2 ½" steel. The inlet panel and bearing support structure shall be attached to a frame constructed of 2"x2"x ¼: steel tubing with continuously welded joints
- C. Wheel shall be aluminum, non-overloading, centrifugal backward inclined, airfoil type. Blades on all sizes shall be continuously welded to the backplate and deep spun inlet shroud. All sizes shall be securely keyed to the fan shaft. Wheel shall overlap an aerodynamic aluminum inlet cone to provide maximum performance and efficiency. Wheel shall be factory balanced in accordance with AMCA standard 204-96, Balance Quality and Vibration Levels for Fans after the fan and motor have been mounted on the factory provided inertia pads.
- D. Blower shaft shall be AISI C-1045 hot rolled and accurately turned, ground and polished. Shafting shall be sized for a critical speed of at least 125% of maximum RPM.
- E. Provide OSHA screened enclosures for plenum fans
- F. Plenum fans shall be as manufacturer by Twin Cities and include Piezometer air flow monitoring stations. Pneumatic lines from air flow stations shall extend through unit casing for use by ATC
- G. All fans shall be mounted on spring isolators. The base shall be of sufficient size and thickness for the fan and motor size as scheduled.
- H. Bearings are to be heavy duty, grease lubricated, anti-friction ball or roller self aligning, pillow block type and selected for minimum average bearing life (AFBMA L-50) in excess of 200,000 hours at the maximum class RPM. All bearings shall be equipped with re-greasable Zerk fittings. Grease fittings shall be at the fan and not extended to the exterior casing.
- I. The unit manufacturer shall provide flexible connection between fan and fan wall. Fan assembly shall be provided with thrust arrestors as required to prevent damage to the flex connection. Flex connection shall be flame retardant fabric suitable for intended use meeting the requirements of NFPA 90A.

2.9 FILTER SECTIONS:

- A. Provide all prefilters and final filters of number, size and capacity as required for air handling system indicated on drawings and as stated in these specifications
- B. Filters shall have nominal rating of 500 fpm. Each cell shall be 24" x 24", or 12" x 24". Initial pressure drop shall not exceed that indicated. Filter media efficiency will be tested in accordance with ASHRAE Test Standard 52-76. Filters will be listed by Underwriters Laboratory (UL) as Class 2.
- C. Media shall be approved and listed as Underwriters Laboratories Class 2 when tested according to UL Standard 900 and as described below:
 - 1. Filters (MERV 8 Prefilter):

- a. Shall be UL Class 2, 2" thick MERV 8 pleated fabric filter for supply filters.
 - b. Filter shall have welded steel wire grid support
 - c. Filters shall not unload or collapse under high velocity or static pressure.
 - d. Efficiency shall be MERV 8 as measured by ASHRAE Test Standard 52-76.
 - e. Initial pressure drop shall be more than 0.28" at a velocity of 500 fpm. Filters shall be designed to operate at up to 500 fpm for the 2" thick filter.
 - f. Provide 2 sets of prefilters
 - g. Filters shall be Farr 30/30 or equivalent by AAF or Aerostar
2. Final HEPA filters (downstream of supply fan section): 12" rigid separator style pleated filter.
- a. HEPA filters shall be extended media separator type filters with a minimum efficiency of 99.97% on 0.30 micrometer particles.
 - b. Filters shall be UL900 Class 2.
 - c. The separator style filter pack shall be constructed by pleating a continuous sheet of non-woven water resistant fiberglass media around hemmed-edge corrugated aluminum separators.
 - d. The filter pack shall be sealed into a galvanized frame with a fire retardant sealant
- D. Filters shall be upstream removable.
- E. Filter frames shall be aluminum or stainless steel construction with associated clips required to hold filter cells. Pre filter and final filter frames to be provided with closed cell neoprene gasketing.
- F. Filter holding frames shall be installed and individually sealed to prevent leakage around frames. Filter banks shall be reinforced with vertical stiffeners to assure rigidity. Unit manufacturer shall provide flashing between filter banks and unit casings to prevent air leakage or bypass around the frames. Installation techniques, sealing methods, and structural reinforcement eliminate unfiltered air bypass and assure system cleanliness based on filter efficiencies specified.
- G. For the HEPA filter frames, provide 11 gauge welded filter racks, using swing arm bolts to secure filters.
- H. Provide filter gauges for each filter as follows:
1. Dwyer Magnahelic Type 2002 AF dry air filter gauge, with scale of 0 to 2" across filter, with appropriate static pressure taps, vent valves, and tubing with flag suitably marked to indicate need to change filter for prefilters and final filters.
- 2.10 AIR BLENDER UNITS (AHU-149 ONLY)
- A. Acceptable Manufacturers: Blender Products, Inc. -Series IV AIR BLENDER® static mixer

- B. Static mixing devices shall be installed where shown on plans to enhance the mixing of outside air with return air to a mixing effectiveness required to eliminate Freeze stat trips, minimize sensor error and enhance outdoor air distribution. Furthermore the air mixing device shall provide even airflow across filters, coils and control sensors.
- C. The pressure drop rating for static air mixers shall include the pressure loss due to the mixer design and the mixer-to- plenum area ratio.
- D. Detailed documentation of performance testing shall be made available upon request
- E. Static air mixers shall be geometrically scaled to ensure consistent performance across full range of sizes offered. Mixers that are not geometrically scaled are not acceptable. Mixers shall be of counter rotational design.
- F. Construction: Static air mixers shall be welded and mechanically fastened .080" or .125" thk. Aluminum. Static air mixers shall have Bare finish.
- G. Installation: Installation shall be in accordance with the manufacturer's written installation instructions and SMACNA plenum construction guidelines. If necessary, provide reinforcing in plenum where the Mixing Device Is Installed To Eliminate Excess Vibration or Deflection Of Blank Off Plenum.

2.11 AIR CONTROL DAMPERS

- A. Dampers shall be low leakage, opposed blade design capable of withstanding 8" wg differential pressure at 2,000 fpm approach velocity. Leakage rate not to exceed 6 CFM per ft.² at 4" wg differential pressure and 2,000 fpm approach velocity.
- B. Damper frames shall be made of extruded aluminum. Damper blades shall be extruded aluminum airfoil shape to withstand high velocities and static pressures. Leakage not to exceed 8 cfm per square foot through a 36 inch by 36 inch damper at 4" w.g. pressure differential
 1. Frames: .080" extruded aluminum. Damper frame is 4 inches deep and is insulated with polystyrofoam. Frame is assembled using type 316 stainless steel screws.
 2. Blades: Airfoil shaped extruded aluminum, maximum 48 inches long. Blades shall be insulated with polyurethane foam and thermally broken.
 3. Bearings: Celcon inner bearing fixed to a 7/16 inch aluminum hexagon blade pin, rotating with a polycarbonate outer bearing inserted in the frame.
 4. Blade Seals: Extruded silicone secured in an integral slot within the aluminum extrusions
 5. Damper shall be selected on the basis of the pressure class. Linkage hardware is installed in the frame side. All aluminum linkage hardware parts are clear anodized. All non-aluminum linkage hardware parts are type 316 stainless steel.
 6. All dampers shall be provided with jack shafts
 7. Control actuators shall be provided by ATC contractor
- C. Acceptable dampers: TAMCO Series 9000 thermally insulated series.

2.12 INJECTION TYPE HUMIDIFIER PANELS:

- A. Each panel shall consist of a steam supply header/separator, a condensate collection header and a bank of closely spaced steam dispersion tubes spanning the distance between the two headers. Each steam outlet in tubes shall contain a steam orifice sized for its required steam capacity. The humidifier shall provide absorption characteristics that preclude water accumulation on any in-duct surface within 36" downstream of the humidifier tube panel while maintaining conditions of 90% (maximum) relative humidity at a minimum temperature of 55°F in the duct air stream. Air pressure loss across humidifier panel shall not exceed 0.10" W.C. at a duct air velocity of 500 FPM. Humidifiers in air handling units shall have assemblies sized to match the unit's cooling coil casing size. Humidifiers shall be Ultra-Sorb by Dri-Steem. Humidifiers shall be purchased locally.
- B. Each packaged humidifier panel assembly of tubes and headers shall be contained within a stainless steel metal casing to allow convenient duct mounting or to facilitate the stacking of and/or the end-to-end mounting of multiple panels in ducts or air handler casings.
- C. All tubes and headers shall be of 304 stainless steel and joints shall be heli-arc welded. Tubes shall be joined to headers with slip fit couplers.
- D. Insulated dispersion tubes. Dispersion tubes shall be insulated with a plenum-approved insulating material for in-duct installation and have an R-value not less than 0.5 at a thickness not more than 0.125" (3.2 mm), for minimal increase in dispersion tube diameter.
 1. Airstream heat gain shall not exceed the values as scheduled; the values shall be supported by the manufacturer's published data.
 2. Insulating material shall meet the following criteria at 0.125" (3.2 mm) thickness:
 - a. Fire/smoke index shall be 0/0 per any of the following test procedures:
 - UL 723 fire/smoke index (Test for Surface Burning Characteristics of Building Materials) – NFPA 255 (Standard Method of Test of Surface Burning Characteristics of Building Materials) – ASTM E84 (Surface Burning Characteristics for Materials Used in Plenums).
 - b. Stable up to 300 °F (148 °C) continuous – to prevent material degradation, hardening, or crumbling at high temperatures
 - c. Closed-cell construction does not absorb water or support microbial growth – to negate the need for vapor barriers and jackets
 - d. Non-toxic and pure as documented in manufacturer's data – to prevent off-gassing and to facilitate use in clean rooms, pharmaceutical applications, and food industries
 - e. Will not degrade when exposed to UVC light – to negate the need for UV wraps
 - f. Continuous, seam-welded, and held in place without bands or clamps – to minimize surfaces for the accumulation of particulate matter

2.13 MOTORIZED CONTROL AND SMOKE DAMPERS

- A. Dampers shall be UL555S rates as manufactured by Ruskin Inc. or approved equal.
- B. Leakage characteristics shall be based upon test procedures per AMCA Standard 500 that shows air leakage at 6 cfm per sq. ft at 4" wg differential pressure. Dampers shall be suitable for 9" w.c. static pressure and 6000 FPM free velocities.

- C. Frames and blades to be minimum 12 ga. (.081") extruded aluminum. Blades to be of single unit design.
- D. Provide overlapping blades and seals (not just overlap seals) to assure minimum air leakage. Provide extruded silicone seals fit into a ribbed groove insert in blades with a formed stainless steel, spring steel at the jamb.
- E. Rod bearings shall be designed so that there shall be no metal-to-metal or metal-to-bearing riding surfaces. Interconnecting linkage to have separate Celcon bearing to eliminate friction in linkage.
- F. Blade linkage hardware shall be of non-corrosive reinforced material or cadmium plated steel.
- G. All dampers shall be parallel blade type.

2.14 STEAM TUBE IN TUBE PREHEAT COILS

- A. Acceptable manufacturers subject to compliance with the specifications shall be as follows:
 - 1. Aerofin
 - 2. Heat Craft
 - 3. Marlo
- B. Fins shall be continuous aluminum configured plate fin type, with full fin collars for accurate spacing and maximum fin tube contact with a maximum fins per inch. as scheduled. Minimum fin thickness shall be 0.010".
- C. Tubes shall be copper expanded into fin collars for permanent fin tube bond and expanded into header for leak tight joint at 300 psig air pressure under water. Headers shall be gray cast iron, hydrostatically tested to 400 psi before assembly. All standard coils shall be proof tested at 300 psig and leak tested at 200 psig air under water. Tubing and return bends shall be constructed from UNS 12200 seamless copper conforming to ASTM B75 and ASTM B251 for standard pressure applications. The 5/8" OD inner steam distributing tubes are centered in the outer 1 1/8" OD condensing tube. The inner tube has proportionally spaced directional steam jet orifices that direct the condensate flow to the outlet. Coils shall be suitable for 50 psig steam pressure.
- D. Casings shall be 16 gauge, continuous coated galvanized steel with fins recessed into channels to minimize air bypass, with 3/8" holes on 3" centers in top and bottom channels for mounting.

2.15 COOLING COILS.

- A. Acceptable manufacturers subject to compliance with the specification shall be as follows:
 - 1. Aerofin
 - 2. Heat Craft
 - 3. Marlo
 - 4. Energy Labs
 - 5. Trane
- B. Primary surface shall be round seamless 0.025" thick, 5/8" o.d. copper tubes on 1 1/2" centers, staggered in the direction of airflow. All joints shall be brazed. Tube bends shall be 0.035 thick.

- C. Secondary surface shall consist of aluminum plate type fins for higher capacity and structural strength. Fins shall have a minimum thickness of 0.0095" with full drawn collars to provide a continuous surface cover over the entire tube for maximum heat transfer with a maximum (10) fins per inch. Bare copper tube shall not be visible between fins. Fins shall have no openings punched in them so as to accumulate lint and dirt. Tubes shall be mechanically expanded into fins to provide a continuous primary to secondary compression bond over the entire finned length for maximum heat transfer rates. Tubes that have been expanded through the use of hydraulic expansion methods will not be acceptable.
- D. Casing and tube supports shall be constructed of stainless steel with 3/8" diameter bolt holes for mounting on 8" centers. Casing shall be a minimum of 16 gauge, 304 stainless steel, reinforced flange of a minimum of 1½" deep flange.
- E. Coil header shall be of copper materials using seamless copper tubing with intruded tube holes to permit expansion and contraction without creating undue stress or strain. Coil size shall be determined by coil manufacturer based upon the most efficient coil circuiting. Vent connections at the highest point to ensure proper venting and drain connections shall be provided at the lowest point to ensure complete drainage and prevent freeze-up.
- F. Coils shall have foam sealing strip located between casing channels and fins along top and bottom to arrest air bypass and water carryover.
- G. The complete coil core shall be pressure tested with 315 lbs. air pressure under warm water and shall be suitable for operation at 250 psig working pressure. Individual tube test and core tests before installation of headers will not be considered acceptable. Cooling coils shall be circuited for drainability and for service without removing individual plugs from each tube. Use of internal restrictive devices to obtain turbulent flow will not be acceptable since they prevent complete draining of the coil.
- H. The manufacturer shall furnish coil capacities as outlined in the tabulation. Capacities shall be verified with an ARI approved computer selection method.
- I. The unit manufacturer shall provide separate drains from pan under each coil section. Drains from multiple, stacked coil pans shall be routed individually to drain outlet, not cascaded from one coil pan to the next lower pan.
- J. Cooling coils shall be mounted to allow removal of any coil individually without disturbing any other coils, and shall be bolted off for removal.
- K. Drain pans and support members shall be stainless steel. Coil drain pans shall allow for condensate removal 3 inch upstream and 24 inch downstream of all coils.
- L. Each individual coil module shall have a limited height of up to 36".
- M. Coils shall be fully drainable with drain connection at the bottom of the coil.

2.16 UVC EMITTERS

- A. General:
 - 1. Acceptable Manufacturers:
 - a. Steril-Aire, Inc. Model DE Series as shown on Schedule or Drawings.

- b. Substitutions: (10) day prior approval is required and is to include documentation by a recognized Industry Independent Testing Lab on UVC Emitter performances. Performance results must meet or exceed the performance for Emitters in an HVAC environment as detailed in Paragraphs A, 2.b, Paragraph B, Item 2, and Paragraph C, Items 3, 4 and 5.
 2. Quality Assurance:
 - a. Qualifications: Each component and product is to be inbound and outbound tested before shipment under Mil Standard 105E and ANSI/ASQCZ 1.4
 - b. Output Verification: When tested in accordance with the general provisions of IES Lighting Handbook, 1981 Applications Volume, total output per one inch arc length shall not be less than 10 mW/cm², at one meter, in a 400 fpm airstream of 45° F
 3. Warranty:
 - a. Fixture and Emitter shall be warranted to be free from defects for a period of one year
- B. Design Requirements:
 1. Irradiation - Emitters and fixtures are to be installed in sufficient quantity and in such an arrangement so as to provide an equal distribution of UVC energy on the coil and in the drain pan. To maintain energy efficiency, the UVC energy produced shall be of the lowest possible reflected and shadowed losses.
 2. Intensity - The minimal UVC energy striking the leading edge of all the coil fins shall not be less than 1400 mW/cm². This sets the quantity of fixtures to be installed and their placement.
 3. Installation - Emitters and fixtures shall be installed downstream of the cooling coil at right angles to the coil fins, such that UVC energy bathes all surfaces of the coil and drain pan
- C. Equipment:
 1. Units shall be high output, HVAC-type, germicidal UVC light sources, factory assembled and tested. Components shall include a housing, reflector, high efficiency electronic power source, Emitter sockets and boots, and Emitter tube, all constructed to withstand HVAC environments.
 2. DE Unit housings shall be made of 304 stainless steel, with DE Units having electrical connectors on both ends to simplify gang wiring and wiring to power. They shall include mounting holes to assist in securing the fixtures.
 3. DE reflectors shall be constructed of high spectral finished aluminum alloy with a minimum 85% reflectance of 254-nm UVC energy.
 4. High efficiency electronic power sources shall be 115 Vac/60/1. They shall be UL listed to comply with UL Standard 1995 and capable of igniting each Emitter at temperatures from 35 - 170° F in airflow velocities to 1000 fpm. They shall be equipped with RF and line noise suppression.
 5. Emitter tube shall be of the high output, hot cathode, T5 (15mm) diameter, and medium bi-pin type. They shall produce 95% of their energy at 254 nm and be capable of producing the specified output at airflow velocities to 1000 fpm at temperatures of 35 - 170° F. UVC Emitters shall produce no ozone or other secondary contamination.
- D. Installation of UVC Emitters

1. Emitters shall be installed and wired at the AHU manufacturer using an aluminum framing system provided by Steril-Aire.
2. Provide an interlock switch on the access to the UVC Emitters to turn the lights off when the access is opened.
3. Install provided Caution Labels on all accesses to the Emitters

2.17 OUTSIDE AIR MONITOR

- A. The monitor/controller shall be capable of direct measurement of airflow through an outside air inlet and provide an input to the building automation system that is linear to the measured airflow rate.
- B. The monitor/controller shall measure inlet airflow with an accuracy of $\pm 0.5\%$ of reading over a range of and within $\pm 5\%$ for operating ranges as low as 100 fpm, and shall be manufactured by Ebtron. Provide with manufacturer's transducer.
- C. The monitor/controller shall interface with existing building management systems, accepting inputs for fan system start, economizer mode operation, and an external controller setpoint, and provide flow deviation alarm outputs.
- D. The sensors shall be constructed of materials that resist corrosion due to the presence of salt or chemicals in the air; all non-painted surfaces shall be constructed of stainless steel. The electronics enclosure shall be NEMA 1.
- E. The airflow measurement system shall be tested in accordance with AMCA Standard 610-06, Figure 4 and AMCA Standards 611-06 Certified Ratings program. The airflow measurement system shall bear the AMCA International certified ratings seal for airflow measurement station performance.

2.18 UNIT DISCHARGE SECTION

- A. Discharge section with exit velocities exceeding 1500 fpm shall be complete with aerodynamically designed framed discharge openings or spun bellmouth fittings in order to reduce overall system static pressures.
- B. Bellmouth fittings shall have minimum radius equal to 20% of the diameter (round or oval) or shortest side (rectangular) to provide optimum performance. Bellmouths with radius less than 2" are not acceptable. Bellmouth to be mounted flush with unit interior edge to minimize exit loss.
- C. Openings shall conform to the size and configuration of the ductwork where shown

2.19 ROOF CURBS

- A. Materials: Galvanized steel with corrosion-protection coating, watertight gaskets, and factory-installed wood nailer; complying with NRCA standards.
 1. Curb Insulation and Adhesive: Comply with NFPA 90A or NFPA 90B.
 - a. Materials: ASTM C 1071, Type I or II.
 - b. Thickness: 2 inches (50 mm)
 2. Application: Factory applied with adhesive and mechanical fasteners to the internal surface of curb.

- a. Liner Adhesive: Comply with ASTM C 916, Type I.
 - b. Mechanical Fasteners: Galvanized steel, suitable for adhesive attachment, mechanical attachment, or welding attachment to duct without damaging liner when applied as recommended by manufacturer and without causing leakage in cabinet.
 - c. Liner materials applied in this location shall have air-stream surface coated with a temperature-resistant coating or faced with a plain or coated fibrous mat or fabric depending on service air velocity.
 - d. Liner Adhesive: Comply with ASTM C 916, Type I.
- B. Curb Height: 24 inches (610 mm)
- C. Wind and Seismic Restraints: Metal brackets compatible with the curb and casing, painted to match RTU, used to anchor unit to the curb, and designed for loads at Project site. Comply with requirements in Division 23 Section "Vibration and Seismic Controls for HVAC Piping and Equipment" for wind-load requirements.

PART 3 - EXECUTION

3.1 EXAMINATION

- A. Examine substrates, areas, and conditions, with Installer present, for compliance with requirements for installation tolerances and other conditions affecting performance of AHUs.
- B. Examine roughing-in for AHUs to verify actual locations of piping and duct connections before equipment installation
- C. Proceed with installation only after unsatisfactory conditions have been corrected

3.2 CONNECTIONS

- A. Install condensate drain, minimum connection size, with trap and indirect connection to nearest roof drain or area drain.
- B. Install piping adjacent to RTU's to allow service and maintenance.
- C. Duct installation requirements are specified in other Division 15 Sections. Drawings indicate the general arrangement of ducts. The following are specific connection requirements
 - 1. Remove roof decking only as required for passage of ducts.
 - 2. Connect supply ducts to RTUs with flexible duct connectors

3.3 FIELD QUALITY CONTROL

- A. Manufacturer's Field Service: Engage a factory-authorized service representative to inspect, test, and adjust components, assemblies, and equipment installations, including connections. Report results in writing.
- B. Perform tests and inspections and prepare test reports
 - 1. Manufacturer's Field Service: Engage a factory-authorized service representative to inspect components, assemblies, and equipment installations, including connections, and to assist in testing. Report results in writing.

- C. Tests and Inspections:
 - 1. After installing AHUs and after electrical circuitry has been energized, test units for compliance with requirements.
 - 2. Inspect for and remove shipping bolts, blocks, and tie-down straps.
 - 3. Operational Test: After electrical circuitry has been energized, start units to confirm proper motor rotation and unit operation.
 - 4. Test and adjust controls and safeties. Replace damaged and malfunctioning controls and equipment
- D. Remove and replace malfunctioning units and retest as specified above.

3.4 STARTUP SERVICE

- A. Engage a factory-authorized service representative to perform startup service.
- B. Complete installation and startup checks according to manufacturer's written instructions and do the following:
 - 1. Inspect for visible damage to unit casing.
 - 2. Inspect for visible damage to compressor, coils, and fans.
 - 3. Inspect internal insulation.
 - 4. Verify that labels are clearly visible.
 - 5. Verify that clearances have been provided for servicing.
 - 6. Verify that controls are connected and operable.
 - 7. Verify that filters are installed.
 - 8. Remove packing from vibration isolators.
 - 9. Retain first subparagraph below for barometric relief dampers
 - 10. Verify lubrication on fan and motor bearings.
 - 11. Inspect fan-wheel rotation for movement in correct direction without vibration and binding.
 - 12. Start unit according to manufacturer's written instructions
 - a. Complete startup sheets and attach copy with Contractor's startup report.
 - 13. Inspect and record performance of interlocks and protective devices; verify sequences.
 - 14. Operate unit for an initial period as recommended or required by manufacturer.
 - 15. Calibrate thermostats.
 - 16. Adjust and inspect high-temperature limits.
 - 17. Inspect outdoor-air dampers for proper stroke and interlock with return-air dampers.
 - 18. Inspect controls for correct sequencing of heating, dampers, cooling, and normal and emergency shutdown.
 - 19. Measure and record the following minimum and maximum airflows. Plot fan volumes on fan curve
 - a. Supply-air volume, return air volume.
 - 20. Verify operation of remote panel including pilot-light operation and failure modes. Inspect the following:
 - a. Low-temperature safety operation.
 - b. Filter high-pressure differential alarm.
 - c. Smoke and firestat alarms.
 - 21. After startup and performance testing and prior to Substantial Completion, replace existing filters with new filters

3.5 CLEANING AND ADJUSTING

- A. After completing system installation and testing, adjusting, and balancing AHU and air-distribution systems, clean filter housings and install new filters.

3.6 DEMONSTRATION

- A. Engage a factory-authorized service representative to train Owner's maintenance personnel to adjust, operate, and maintain AHUs. Refer to Division 01 Section "Demonstration and Training."

END OF SECTION

This page is intentionally left blank.

SECTION 237413

PACKAGED, OUTDOOR, CENTRAL-STATION AIR-CONDITIONING UNITS

PART 1 - GENERAL

1.1 RELATED DOCUMENTS

- A. Drawings and general provisions of the Contract, including General and Supplementary Conditions and Division 01 Specification Sections, apply to this Section.

1.2 SUMMARY

- A. This Section includes packaged, outdoor, central-station air-handling units (rooftop units) with the following components and accessories:
 - 1. Direct-expansion cooling.
 - 2. Economizer outdoor- and exhaust-air damper section.
 - 3. Integral, space temperature controls.
 - 4. Roof curbs.
- B. Related Sections include the following:
 - 1. Division 23 Section "Packaged, Outdoor, Heating and Cooling Makeup Air-Conditioners" for outdoor equipment air conditioning 100 percent outdoor air to replace air exhausted from a building.

1.3 DEFINITIONS

- A. DDC: Direct-digital controls.
- B. ECM: Electrically commutated motor.
- C. RTU: Rooftop unit. As used in this Section, this abbreviation means packaged, outdoor, central-station air-handling units. This abbreviation is used regardless of whether the unit is mounted on the roof or on a concrete base on ground.
- D. Supply-Air Fan: The fan providing supply air to conditioned space. "Supply air" is defined as the air entering a space from air-conditioning, heating, or ventilating apparatus.
- E. Supply-Air Refrigerant Coil: Refrigerant coil in the supply-air stream to absorb heat (provide cooling) during cooling operations and to reject heat (provide heating) during heating operations. "Supply air" is defined as the air entering a space from air-conditioning, heating, or ventilating apparatus.
- F. VVT: Variable-air volume and temperature.

1.4 PERFORMANCE REQUIREMENTS

- A. Delegated Design: Design RTU supports to comply with seismic performance requirements, including comprehensive engineering analysis by a qualified

professional engineer, using performance requirements and design criteria indicated.

- B. Seismic Performance: RTUs shall withstand the effects of earthquake motions determined according to SEI/ASCE 7
 - 1. The term "withstand" means "the unit will remain in place without separation of any parts from the device when subjected to the seismic forces specified."

1.5 SUBMITTALS

- A. Product Data: Include manufacturer's technical data for each RTU, including rated capacities, dimensions, required clearances, characteristics, furnished specialties, and accessories.
 - 1. Unit dimensions and weight.
 - 2. Cabinet material, metal thickness, finishes, insulation, and accessories.
 - 3. Fans:
 - a. Certified fan-performance curves with system operating conditions indicated.
 - b. Submit the family of rpm curves indicating operating point relative to fan class.
 - c. Submit fan selection with system curve indication, operating point, family of all rpm curves in fan class and the "DO NOT SELECT TO THE LEFT OF THIS CURVE". The minimum rpm shall be indicated.
 - d. Certified fan-sound power ratings.
 - e. Certified unit sound power levels at specified rating.
 - f. Fan construction and accessories.
 - g. Motor ratings, electrical characteristics, and motor accessories.
 - 4. Certified coil-performance ratings with system operating conditions indicated.
 - 5. Dampers, including housings, linkages, and operators.
 - 6. Filters with performance characteristics.
 - 7. Ancillary manufacturer provided piping and equipment supports.
 - 8. Drain pan configuration
 - 9. Roof curbs and unit base construction
- B. LEED Submittals:
 - 1. Product Data for Credit EA 4: For refrigerants, including printed statement that refrigerants are free of HCFCs.
- C. Shop Drawings: Detail equipment assemblies and indicate dimensions, weights, loads, required clearances, method of field assembly, components, and location and size of each field connection.
 - 1. Wiring Diagrams: Power, signal, and control wiring.
- D. Delegated-Design Submittal: For RTU supports indicated to comply with performance requirements and design criteria, including analysis data signed and sealed by the qualified professional engineer responsible for their preparation.
 - 1. Design Calculations: Calculate requirements for selecting vibration isolators and seismic restraints and for designing vibration isolation bases.
 - 2. Detail mounting, securing, and flashing of roof curb to roof structure. Indicate coordinating requirements with roof membrane system.
 - 3. Seismic-Restraint Details: Detail fabrication and attachment of wind and seismic restraints and snubbers. Show anchorage details and indicate quantity, diameter, and depth of penetration of anchors.

- E. Manufacturer Seismic Qualification Certification: Submit certification that RTUs, accessories, and components will withstand seismic forces defined in "Performance Requirements" Article and in Division 23 Section "Vibration and Seismic Controls for HVAC Piping and Equipment."
 - 1. Basis for Certification: Indicate whether withstand certification is based on actual test of assembled components or on calculation.
 - 2. Dimensioned Outline Drawings of Equipment Unit: Identify center of gravity and locate and describe mounting and anchorage provisions.
 - 3. Detailed description of equipment anchorage devices on which the certification is based and their installation requirements.
- F. Coordination Drawings: Plans and other details, drawn to scale, on which the following items are shown and coordinated with each other, using input from installers of the items involved:
 - 1. Structural members to which RTUs will be attached.
 - 2. Roof openings
 - 3. Roof curbs and flashing.
- G. Field quality-control test reports.
- H. Operation and Maintenance Data: For RTUs to include in emergency, operation, and maintenance manuals.
- I. Warranty: Special warranty specified in this Section.

1.6 QUALITY ASSURANCE

- A. AHRI Compliance:
 - 1. Comply with AHRI 210/240 and AHRI 340/360 for testing and rating energy efficiencies for RTUs.
 - 2. Comply with AHRI 270 for testing and rating sound performance for RTUs.
- B. ASHRAE Compliance:
 - 1. Comply with ASHRAE 15 for refrigeration system safety.
 - 2. Comply with ASHRAE 33 for methods of testing cooling and heating coils.
 - 3. Comply with ASHRAE/IESNA 90.1 for minimum efficiency of heating and cooling.
- C. NFPA Compliance: Comply with NFPA 90A and NFPA 90B.
- D. UL Compliance: Comply with UL 1995.
- E. Electrical Components, Devices, and Accessories: Listed and labeled as defined in NFPA 70, Article 100, by a testing agency acceptable to authorities having jurisdiction, and marked for intended use.

1.7 WARRANTY

- A. Special Warranty: Manufacturer's standard form in which manufacturer agrees to replace components of RTUs that fail in materials or workmanship within specified warranty period.
 - 1. Warranty Period for Compressors: Manufacturer's standard, but not less than five years from date of Substantial Completion.
 - 2. Warranty Period for Control Boards: Manufacturer's standard, but not less than three years from date of Substantial Completion.

1.8 EXTRA MATERIALS

- A. Furnish extra materials described below that match products installed and that are packaged with protective covering for storage and identified with labels describing contents.
 - 1. Filters: One set of filters for each unit.

PART 2 - PRODUCTS

2.1 MANUFACTURERS

- A. Manufacturers: Subject to compliance with requirements, provide products by one of the following:
 - 1. Trane; American Standard Companies, Inc.
 - 2. YORK International Corporation.

2.2 CASING

- A. General Fabrication Requirements for Casings: Formed and reinforced double-wall insulated panels, fabricated to allow removal for access to internal parts and components, with joints between sections sealed.
- B. Exterior Casing Material: Galvanized steel with factory-painted finish, with pitched roof panels and knockouts with grommet seals for electrical and piping connections and lifting lugs.
 - 1. Exterior Casing Thickness: 0.052 inch thick.
- C. Inner Casing Fabrication Requirements:
 - 1. Inside Casing: Galvanized steel, 0.034 inch thick].
- D. Casing Insulation and Adhesive: Comply with NFPA 90A or NFPA 90B.
 - 1. Materials: ASTM C 1071, Type I.
 - 2. Thickness: 1 inch (25 mm).
 - 3. Liner materials shall have air-stream surface coated with an erosion- and temperature-resistant coating or faced with a plain or coated fibrous mat or fabric.
 - 4. Liner Adhesive: Comply with ASTM C 916, Type I.
- E. Condensate Drain Pans: Formed sections of stainless-steel sheet, a minimum of 2 inches (50 mm) deep, and complying with ASHRAE 62.
 - 1. Double-Wall Construction: Fill space between walls with foam insulation and seal moisture tight.
 - 2. Drain Connections: Threaded nipple.
 - 3. Pan-Top Surface Coating: Corrosion-resistant compound.

2.3 FANS

- A. Direct-Driven Supply-Air Fans: Plenum fan; with permanently lubricated, ECM motor resiliently mounted in the fan inlet. Aluminum or painted-steel wheels, and galvanized- or painted-steel fan scrolls.
- B. Condenser-Coil Fan: Propeller, mounted on shaft of permanently lubricated motor.
- C. Relief-Air Fan: Propeller shaft mounted on permanently lubricated motor.

- D. Seismic Fabrication Requirements: Fabricate fan section, internal mounting frame and attachment to fans, fan housings, motors, casings, accessories, and other fan section components with reinforcement strong enough to withstand seismic forces defined in Division 23 Section "Vibration and Seismic Controls for HVAC Piping and Equipment" when fan-mounted frame and RTU-mounted frame are anchored to building structure.
- E. Fan Motor: Comply with requirements in Division 23 Section "Common Motor Requirements for HVAC Equipment."

2.4 COILS

- A. Supply-Air Refrigerant Coil:
 - 1. Aluminumplate fin and seamlesscopper tube in steel casing with equalizing-type vertical distributor.
 - 2. Polymer strip shall prevent all copper coil from contacting steel coil frame or condensate pan.
 - 3. Coil Split: Interlaced.
 - 4. Condensate Drain Pan: Stainless steel formed with pitch and drain connections complying with ASHRAE 62.
- B. Outdoor-Air Refrigerant Coil:
 - 1. Aluminumplate fin and seamlesscopper tube in steel casing with equalizing-type vertical distributor.
 - 2. Polymer strip shall prevent all copper coil from contacting steel coil frame or condensate pan.

2.5 REFRIGERANT CIRCUIT COMPONENTS

- A. Number of Refrigerant Circuits: Two
- B. Compressor: Hermetic, scroll, mounted on vibration isolators; with internal overcurrent and high-temperature protection, internal pressure relief, and crankcase heater.
- C. Refrigeration Specialties:
 - 1. Refrigerant Charge: R-410A
 - 2. Expansion valve with replaceable thermostatic element.
 - 3. Refrigerant filter/dryer.
 - 4. Manual-reset high-pressure safety switch.
 - 5. Automatic-reset low-pressure safety switch.
 - 6. Minimum off-time relay.
 - 7. Automatic-reset compressor motor thermal overload.
 - 8. Brass service valves installed in compressor suction and liquid lines.
 - 9. Low-ambient kit high-pressure sensor.

2.6 AIR FILTRATION

- A. Minimum arrestance according to ASHRAE 52.1, and a minimum efficiency reporting value (MERV) according to ASHRAE 52.2.
 - 1. Pleated: Minimum 90percent arrestance, and MERV 7

2.7 DAMPERS

- A. Outdoor- and Return-Air Mixing Dampers: Parallel- or opposed-blade galvanized-steel dampers mechanically fastened to cadmium plated for galvanized-steel operating rod in reinforced cabinet. Connect operating rods with common linkage and interconnect linkages so dampers operate simultaneously.
 - 1. Damper Motor: Modulating with adjustable minimum position.
 - 2. Relief-Air Damper: Gravity actuated with bird screen and hood.

2.8 ELECTRICAL POWER CONNECTION

- A. Provide for single connection of power to unit with unit-mounted disconnect switch accessible from outside unit and control-circuit transformer with built-in overcurrent protection.

2.9 CONTROLS

- A. Control equipment and sequence of operation are specified in Division 23 Section "Instrumentation and Control for HVAC."
- B. Basic Unit Controls:
 - 1. Control-voltage transformer.
 - 2. Wall-mounted thermostat or sensor with the following features:
 - a. Heat-cool-off switch.
 - b. Fan on-auto switch.
 - c. Fan-speed switch.
 - d. Automatic changeover.
 - e. Adjustable deadband.
 - f. Exposed set point.
 - g. Exposed indication.
 - h. Degree Findication.
 - i. Unoccupied-period-override push button.
 - j. Data entry and access port to input temperatureset points, occupied and unoccupied periods, and output room temperature, supply-air temperature, operating mode, and status.
- C. DDC Controller:
 - 1. Controller shall have volatile-memory backup.
 - 2. Safety Control Operation:
 - a. Smoke Detectors: Stop fan and close outdoor-air damper if smoke is detected. Provide additional contacts for alarm interface to fire alarm control panel.
 - 3. Supply Fan Operation:
 - a. Occupied Periods: Run fan continuously.
 - b. Unoccupied Periods: Cycle fan to maintain setback temperature.
 - 4. Refrigerant Circuit Operation:
 - a. Occupied Periods: Cycle or stage compressorsto match compressor output to cooling load to maintain roomtemperature. Cycle condenser fans to maintain maximum hot-gas pressure. Operate low-ambient control kit to maintain minimum hot-gas pressure.
 - 5. Fixed Minimum Outdoor-Air Damper Operation:
 - a. Occupied Periods: Open to minimum position to maintain minimum outdoor air setpoint as determined by the balancing contractor.

- b. Unoccupied Periods: Close the outdoor-air damper.
- 6. Economizer Outdoor-Air Damper Operation:
 - a. Occupied Periods: Open to fixed minimum intake, and maximum 100 percent of the fan capacity to comply with ASHRAE Cycle II. Controller shall permit air-side economizer operation when outdoor air is less than 60 deg F Use mixed-air and outdoor-air temperature to adjust mixing dampers. Start relief-air fan with end switch on outdoor-air damper. During economizer cycle operation, lock out cooling.
- 7. Carbon Dioxide Sensor Operation:
- D. Interface Requirements for HVAC Instrumentation and Control System:
 - 1. Interface relay for scheduled operation.
 - 2. Interface relay to provide indication of fault at the central workstation and diagnostic code storage.
 - 3. Provide BACnet compatible interface for central HVAC control workstation for the following:
 - a. Adjusting set points.
 - b. Monitoring supply fan start, stop, and operation.
 - c. Inquiring data to include outdoor-air damper position, supply- and room-air temperature.
 - d. Monitoring occupied and unoccupied operations.

2.10 ACCESSORIES

- A. Low-ambient kit using staged condenser fans for operation down to 0 deg F
- B. Filter differential pressure switch with sensor tubing on either side of filter. Set for final filter pressure loss.
- C. Coil guards of painted, galvanized-steel wire.
- D. Hail guards of galvanized steel, painted to match casing.

2.11 ROOF CURBS

- A. Materials: Galvanized steel with corrosion-protection coating, watertight gaskets, and factory-installed wood nailer; complying with NRCA standards.
 - 1. Curb Insulation and Adhesive: Comply with NFPA 90A or NFPA 90B.
 - a. Materials: ASTM C 1071, Type I or II.
 - b. Thickness: 2 inches (50 mm)
 - 2. Application: Factory applied with adhesive and mechanical fasteners to the internal surface of curb.
 - a. Liner Adhesive: Comply with ASTM C 916, Type I.
 - b. Mechanical Fasteners: Galvanized steel, suitable for adhesive attachment, mechanical attachment, or welding attachment to duct without damaging liner when applied as recommended by manufacturer and without causing leakage in cabinet.
 - c. Liner materials applied in this location shall have air-stream surface coated with a temperature-resistant coating or faced with a plain or coated fibrous mat or fabric depending on service air velocity.
 - d. Liner Adhesive: Comply with ASTM C 916, Type I.
- B. Curb Height: 24 inches

- C. Seismic Restraints: Metal brackets compatible with the curb and casing, painted to match RTU, used to anchor unit to the curb, and designed for loads at Project site. Comply with requirements in Division 23 Section "Vibration and Seismic Controls for HVAC Piping and Equipment" for wind-load requirements.

PART 3 - EXECUTION

3.1 EXAMINATION

- A. Examine substrates, areas, and conditions, with Installer present, for compliance with requirements for installation tolerances and other conditions affecting performance of RTUs.
- B. Examine roughing-in for RTUs to verify actual locations of piping and duct connections before equipment installation.
- C. Examine roofs for suitable conditions where RTUs will be installed.
- D. Proceed with installation only after unsatisfactory conditions have been corrected.

3.2 INSTALLATION

- A. Roof Curb: Install on roof structure or concrete base, level and secure, according to NRCA's "Low-Slope Membrane Roofing Construction Details Manual," Illustration "Raised Curb Detail for Rooftop Air Handling Units and Ducts." Install RTUs on curbs and coordinate roof penetrations and flashing with roof construction specified in Division 07 Section "Roof Accessories." Secure RTUs to upper curb rail, and secure curb base to roof framing or concrete base with anchor bolts.
- B. Install seismic restraints according to manufacturer's written instructions

3.3 CONNECTIONS

- A. Install condensate drain, minimum connection size, with trap and indirect connection to nearest roof drain or area drain.
- B. Install piping adjacent to RTUs to allow service and maintenance.
- C. Duct installation requirements are specified in other Division 23 Sections. Drawings indicate the general arrangement of ducts. The following are specific connection requirements:
 - 1. Connect supply ducts to RTUs with flexible duct connectors specified in Division 23 Section "Air Duct Accessories."
 - 2. Install normal-weight, 3000-psi (20.7-MPa), compressive strength (28-day) concrete mix inside roof curb, 4 inches (100 mm) thick. Concrete, formwork, and reinforcement are specified in Division 03.

3.4 FIELD QUALITY CONTROL

- A. Perform tests and inspections and prepare test reports.
 - 1. Manufacturer's Field Service: Engage a factory-authorized service representative to inspect components, assemblies, and equipment

installations, including connections, and to assist in testing. Report results in writing.

- B. Tests and Inspections:
 - 1. After installing RTUs and after electrical circuitry has been energized, test units for compliance with requirements.
 - 2. Inspect for and remove shipping bolts, blocks, and tie-down straps.
 - 3. Operational Test: After electrical circuitry has been energized, start units to confirm proper motor rotation and unit operation.
 - 4. Test and adjust controls and safeties. Replace damaged and malfunctioning controls and equipment.
- C. Remove and replace malfunctioning units and retest as specified above.

3.5 STARTUP SERVICE

- A. Engage a factory-authorized service representative to perform startup service.
- B. Complete installation and startup checks according to manufacturer's written instructions and do the following:
 - 1. Inspect for visible damage to unit casing.
 - 2. Inspect for visible damage to compressor, coils, and fans.
 - 3. Inspect internal insulation.
 - 4. Verify that labels are clearly visible.
 - 5. Verify that clearances have been provided for servicing.
 - 6. Verify that controls are connected and operable.
 - 7. Verify that filters are installed.
 - 8. Clean condenser coil and inspect for construction debris.
 - 9. Remove packing from vibration isolators.
 - 10. Inspect operation of barometric relief dampers.
 - 11. Verify lubrication on fan and motor bearings.
 - 12. Inspect fan-wheel rotation for movement in correct direction without vibration and binding.
 - 13. Start unit according to manufacturer's written instructions.
 - a. Start refrigeration system.
 - b. Do not operate below recommended low-ambient temperature.
 - c. Complete startup sheets and attach copy with Contractor's startup report.
 - 14. Inspect and record performance of interlocks and protective devices; verify sequences.
 - 15. Operate unit for an initial period as recommended or required by manufacturer.
 - 16. Calibrate thermostats.
 - 17. Adjust and inspect high-temperature limits.
 - 18. Inspect outdoor-air dampers for proper stroke and interlock with return-air dampers.
 - 19. Start refrigeration system and measure and record the following when ambient is a minimum of 15 deg F (8 deg C) above return-air temperature:
 - a. Coil leaving-air, dry- and wet-bulb temperatures.
 - b. Coil entering-air, dry- and wet-bulb temperatures.
 - c. Outdoor-air, dry-bulb temperature.
 - d. Outdoor-air-coil, discharge-air, dry-bulb temperature.

20. Inspect controls for correct sequencing of heating, mixing dampers, refrigeration, and normal and emergency shutdown.
21. Measure and record the following minimum and maximum airflows. Plot fan volumes on fan curve.
 - a. Supply-air volume.
 - b. Return-air volume.
 - c. Relief-air volume.
 - d. Outdoor-air intake volume.
22. Simulate maximum cooling demand and inspect the following:
 - a. Compressor refrigerant suction and hot-gas pressures.
 - b. Short circuiting of air through condenser coil or from condenser fans to outdoor-air intake.
23. Verify operation of remote panel including pilot-light operation and failure modes. Inspect the following:
 - a. High-temperature limit on gas-fired heat exchanger.
 - b. Low-temperature safety operation.
 - c. Filter high-pressure differential alarm.
 - d. Economizer to minimum outdoor-air changeover.
 - e. Relief-air fan operation.
 - f. Smoke and firestat alarms.
24. After startup and performance testing and prior to Substantial Completion, replace existing filters with new filters.

3.6 CLEANING AND ADJUSTING

- A. After completing system installation and testing, adjusting, and balancing RTU and air-distribution systems, clean filter housings and install new filters.

3.7 DEMONSTRATION

- A. Engage a factory-authorized service representative to train Owner's maintenance personnel to adjust, operate, and maintain RTUs. Refer to Division 01 Section "Demonstration and Training."

END OF SECTION

SECTION 23 81 26

SPLIT-SYSTEM AIR-CONDITIONERS

PART 1 - GENERAL

1.1 RELATED DOCUMENTS

- A. Drawings and general provisions of the Contract, including General and Supplementary Conditions and Division 01 Specification Sections, apply to this Section.
- B. Section 01 81 13 "Sustainable Design Requirements – LEED v4 for Building Design & Construction – New Construction" for sustainable design requirements and detailed sustainable design submittal requirements.
- C. Section 01 74 19 "Construction and Demolition Waste Management and Disposal" for disposal of construction, demolition and packaging waste disposal requirements.

1.2 SUMMARY

- A. This Section includes split-system air-conditioning units consisting of separate evaporator-fan and compressor-condenser components. Units are designed for exposed or concealed mounting, and may be connected to ducts.
- B. Sustainable Building Requirements:
 - 1. The Owner requires the Contractor to implement practices and procedures to meet the project's environmental performance goals, which include achieving LEED version 4 **Certified** level Certification. Specific project goals that may impact this area of work include: use of recycled-content materials; use of locally-manufactured materials; use of low-emitting materials; construction waste recycling; and the implementation of a construction indoor air quality management plan. The Contractor shall ensure that the requirements related to these goals, as defined in the Articles below, are implemented to the fullest extent. Substitutions, or other changes to the work proposed by the Contractor or their Subcontractors, shall not be allowed if such changes compromise the aforementioned environmental goals and LEED certification.

1.3 SUBMITTALS

- A. Product Data: Include rated capacities, furnished specialties, and accessories for each type of product indicated. Include performance data in terms of capacities, outlet velocities, static pressures, sound power characteristics, motor requirements, and electrical characteristics.
- B. Shop Drawings: Diagram power, signal, and control wiring.
- C. Samples for Initial Selection: For units with factory-applied color finishes.
- D. Operation and Maintenance Data: For split-system air-conditioning units to include in emergency, operation, and maintenance manuals.
- E. Warranty: Special warranty specified in this Section.

1.4 QUALITY ASSURANCE

- A. Product Options: Drawings indicate size, profiles, and dimensional requirements of split-system units and are based on the specific system indicated. Refer to Division 01 Section "Product Requirements."
- B. Electrical Components, Devices, and Accessories: Listed and labeled as defined in NFPA 70, Article 100, by a testing agency acceptable to authorities having jurisdiction, and marked for intended use.
- C. Energy-Efficiency Ratio: Equal to or greater than prescribed by ASHRAE 90.1, "Energy Efficient Design of New Buildings except Low-Rise Residential Buildings."
- D. Coefficient of Performance: Equal to or greater than prescribed by ASHRAE 90.1, "Energy Efficient Design of New Buildings except Low-Rise Residential Buildings."
- E. Units shall be designed to operate with HCFC-free refrigerants.

1.5 COORDINATION

- A. Coordinate size and location of concrete bases for units. Cast anchor-bolt inserts into bases. Concrete, reinforcement, and formwork are specified in Division 03 Section "Cast-in-Place Concrete."
- B. Coordinate size, location, and connection details with roof curbs, equipment supports, and roof penetrations specified in Division 07 Section "Roof Accessories."

1.6 WARRANTY

- A. Special Warranty: Manufacturer's standard form in which manufacturer agrees to repair or replace components of split-system air-conditioning units that fail in materials or workmanship within specified warranty period.
 - 1. Warranty Period: Five years from date of Substantial Completion.

PART 2 - PRODUCTS

2.1 MANUFACTURERS

- A. Manufacturers: Subject to compliance with requirements, provide products by one of the following:
 - 1. Daiken.
 - 2. Mitsubishi Electronics America, Inc.; HVAC Division.
 - 3. Sanyo Fisher (U.S.A.) Corp..
 - 4. Trane Company (The); Unitary Products Group.

2.2 WALL-MOUNTING, EVAPORATOR-FAN COMPONENTS

- A. Cabinet: Enameled steel with removable panels on front and ends in color selected by Architect, and discharge drain pans with drain connection.
- B. Refrigerant Coil: Copper tube, with mechanically bonded aluminum fins, complying with ARI 210/240, and with thermal-expansion valve.
- C. Fan: Direct drive, centrifugal fan.

- D. Fan Motors: Comply with requirements in Division 23 Section "Common Motor Requirements for HVAC Equipment."
 - 1. Special Motor Features: Multitapped, multispeed with internal thermal protection and permanent lubrication.
- E. Filters: Permanent, cleanable.

2.3 AIR-COOLED, COMPRESSOR-CONDENSER COMPONENTS

- A. Outdoor unit shall have a sound rating no higher than 60 dB(A) individually.
- B. Outdoor unit shall be able to connect to up to 50 indoor units depending upon model.
- C. Both refrigerant lines from the outdoor unit to indoor units shall be insulated.
- D. The outdoor unit shall have an accumulator with refrigerant level sensors and controls.
- E. The outdoor unit shall have a high pressure safety switch, over-current protection and DC bus protection.
- F. The outdoor unit shall have the ability to operate with a maximum height difference of 164 feet (294 feet optional) and have a total refrigerant tubing length of 3280 feet. The greatest length is not to exceed 541 feet between the outdoor unit and the indoor units without the need for line size changes or traps.
- G. The outdoor unit shall be capable of operating in cooling mode down to -10°F ambient temperature.
- H. The outdoor unit shall have a high efficiency oil separator plus additional logic controls to ensure adequate oil volume in the compressor is maintained.
- I. Unit Cabinet: The casing(s) shall be fabricated of galvanized steel, bonderized and finished. Units cabinets shall be able to withstand 960 hours per ASTM B117 criteria for seacoast protected models.
- J. Fan: Each outdoor unit module shall be furnished with one direct drive, variable speed propeller type fan.
- K. The fan motor shall have inherent protection, have permanently lubricated bearings, and be completely variable speed. The fan shall be factory set for operation under 0 in. WG external static pressure, but capable of normal operation under a maximum of 0,24 in. WG external static pressure via dipswitch.
- L. The fan motor shall be mounted for quiet operation.
- M. The fan shall be provided with a raised guard to prevent contact with moving parts.
- N. The outdoor unit shall have vertical discharge airflow.
- O. Refrigerant: R410A refrigerant shall be required.
- P. Coil: The outdoor coil shall be of nonferrous construction with lanced or corrugated plate fins on copper tubing.
- Q. The coil fins shall have a factory applied corrosion resistant blue-fin finish.
- R. The coil shall be protected with an integral metal guard.

- S. Refrigerant flow from the outdoor unit shall be controlled by means of an inverter driven compressor.
- T. The outdoor coil shall include 4 circuits with two position valves for each circuit, except for the last stage.
- U. Compressor: Each outdoor unit module shall be equipped with one inverter driven scroll hermetic compressor. Non inverter-driven compressors shall not be allowed.
- V. A crankcase heater(s) shall be factory mounted on the compressor(s).
- W. The outdoor unit compressor shall have an inverter to modulate capacity. The capacity shall be completely variable with a turndown of 18%-4% of rated capacity, depending upon unit size
- X. The compressor shall be equipped with an internal thermal overload.
- Y. The compressor shall be mounted to avoid the transmission of vibration.
- Z. The outdoor unit shall be controlled by integral microprocessors.
- AA. The control circuit between the indoor units and the outdoor unit shall be 24VDC completed using a 2-conductor, non-polar twisted pair shielded cable to provide total integration of the system.

2.4 ACCESSORIES

- A. Thermostat: Wireless infrared functioning to remotely control compressor and evaporator fan, with the following features:
 - 1. Compressor time delay.
 - 2. 24-hour time control of system stop and start.
 - 3. Liquid-crystal display indicating temperature, set-point temperature, time setting, operating mode, and fan speed.
 - 4. Fan-speed selection, including auto setting.
- B. Automatic-reset timer to prevent rapid cycling of compressor.
- C. Refrigerant Line Kits: Soft-annealed copper suction and liquid lines factory cleaned, dried, pressurized, and sealed; factory-insulated suction line with flared fittings at both ends.

PART 3 - EXECUTION

3.1 INSTALLATION

- A. Install units level and plumb.
- B. Install evaporator-fan components using manufacturer's standard mounting devices securely fastened to building structure.
- C. Install seismic restraints. Install compressor-condenser components on restrained, spring isolators with a minimum static deflection of 1 inch .Refer to Division 23 Section "Vibration and Seismic Controls for HVAC Piping and Equipment."
- D. Install and connect precharged refrigerant tubing to component's quick-connect fittings. Install tubing to allow access to unit.

3.2 CONNECTIONS

- A. Piping installation requirements are specified in other Division 23 Sections. Drawings indicate general arrangement of piping, fittings, and specialties.
- B. Install piping adjacent to unit to allow service and maintenance.
- C. Ground equipment according to Division 26 Section "Grounding and Bonding for Electrical Systems."
- D. Electrical Connections: Comply with requirements in Division 26 Sections for power wiring, switches, and motor controls.

3.3 FIELD QUALITY CONTROL

- A. Manufacturer's Field Service: Engage a factory-authorized service representative to inspect, test, and adjust field-assembled components and equipment installation, including connections. Report results in writing.
- B. Perform the following field tests and inspections and prepare test reports:
 - 1. Leak Test: After installation, charge system and test for leaks. Repair leaks and retest until no leaks exist.
 - 2. Operational Test: After electrical circuitry has been energized, start units to confirm proper motor rotation and unit operation.
 - 3. Test and adjust controls and safeties. Replace damaged and malfunctioning controls and equipment.
- C. Remove and replace malfunctioning units and retest as specified above.

3.4 STARTUP SERVICE

- A. Engage a factory-authorized service representative to perform startup service.
 - 1. Complete installation and startup checks according to manufacturer's written instructions.

3.5 DEMONSTRATION

- A. Engage a factory-authorized service representative to train Owner's maintenance personnel to adjust, operate, and maintain units. Refer to Division 01 Section "Demonstration and Training."

END OF SECTION

This page is intentionally left blank.

SECTION 238239

UNIT HEATERS

PART 1 - GENERAL

1.1 RELATED DOCUMENTS

- A. Drawings and general provisions of the Contract, including General and Supplementary Conditions and Division 01 Specification Sections, apply to this Section.
- B. Section 01 81 13 "Sustainable Design Requirements – LEED v4 for Building Design & Construction – New Construction" for sustainable design requirements and detailed sustainable design submittal requirements.
- C. Section 01 74 19 "Construction and Demolition Waste Management and Disposal" for disposal of construction, demolition and packaging waste disposal requirements.

1.2 SUMMARY

- A. Section Includes:
 - 1. Cabinet unit heaters with centrifugal fans and hot-watercoils.
 - 2. Propeller unit heaters with electric-resistance heating coils.
- B. Sustainable Building Requirements:
 - 1. The Owner requires the Contractor to implement practices and procedures to meet the project's environmental performance goals, which include achieving LEED version 4 **Certified** level Certification. Specific project goals that may impact this area of work include: use of recycled-content materials; use of locally-manufactured materials; use of low-emitting materials; construction waste recycling; and the implementation of a construction indoor air quality management plan. The Contractor shall ensure that the requirements related to these goals, as defined in the Articles below, are implemented to the fullest extent. Substitutions, or other changes to the work proposed by the Contractor or their Subcontractors, shall not be allowed if such changes compromise the aforementioned environmental goals and LEED certification.

1.3 DEFINITIONS

- A. BAS: Building automation system.
- B. CWP: Cold working pressure.
- C. PTFE: Polytetrafluoroethylene plastic.
- D. TFE: Tetrafluoroethylene plastic.

1.4 SUBMITTALS

- A. Product Data: Include rated capacities, operating characteristics, furnished specialties, and accessories for each product indicated.

- B. Shop Drawings: Detail equipment assemblies and indicate dimensions, weights, loads, required clearances, method of field assembly, components, and location and size of each field connection.
 - 1. Plans, elevations, sections, and details.
 - 2. Location and size of each field connection.
 - 3. Details of anchorages and attachments to structure and to supported equipment.
 - 4. Equipment schedules to include rated capacities, operating characteristics, furnished specialties, and accessories.
 - 5. Location and arrangement of piping valves and specialties.
 - 6. Location and arrangement of integral controls.
 - 7. Wiring Diagrams: Power, signal, and control wiring.
- C. Coordination Drawings: Floor plans, reflected ceiling plans, and other details, drawn to scale, on which the following items are shown and coordinated with each other, based on input from installers of the items involved:
 - 1. Suspended ceiling components.
 - 2. Structural members to which unit heaters will be attached.
 - 3. Method of attaching hangers to building structure.
 - 4. Size and location of initial access modules for acoustical tile.
 - 5. Items penetrating finished ceiling, including the following:
 - a. Lighting fixtures.
 - b. Air outlets and inlets.
 - c. Speakers.
 - d. Sprinklers.
 - e. Access panels.
 - 6. Perimeter moldings for exposed or partially exposed cabinets.
- D. Samples for Initial Selection: Finish colors for units with factory-applied color finishes.
- E. Samples for Verification: Finish colors for each type of cabinet unit heater and wall and ceiling heaters indicated with factory-applied color finishes.
- F. Manufacturer Seismic Qualification Certification: Submit certification that cabinet unit heaters, accessories, and components will withstand seismic forces defined in Division 23 Section "Vibration and Seismic Controls for HVAC Piping and Equipment." Include the following:
 - 1. Basis for Certification: Indicate whether withstand certification is based on actual test of assembled components or on calculation.
 - a. The term "withstand" means "the unit will remain in place without separation of any parts from the device when subjected to the seismic forces specified."
 - b. The term "withstand" means "the unit will remain in place without separation of any parts from the device when subjected to the seismic forces specified and the unit will be fully operational after the seismic event."
 - 2. Dimensioned Outline Drawings of Equipment Unit: Identify center of gravity and locate and describe mounting and anchorage provisions.
 - 3. Detailed description of equipment anchorage devices on which the certification is based and their installation requirements.
- G. Field quality-control test reports.

- H. Operation and Maintenance Data: For cabinet unit heaters to include in emergency, operation, and maintenance manuals.

1.5 QUALITY ASSURANCE

- A. Electrical Components, Devices, and Accessories: Listed and labeled as defined in NFPA 70, Article 100, by a testing agency acceptable to authorities having jurisdiction, and marked for intended use.

1.6 EXTRA MATERIALS

- A. Furnish extra materials described below that match products installed and that are packaged with protective covering for storage and identified with labels describing contents.
 - 1. Cabinet Unit Heater Filters: Furnish onespare filter(s) for each filter installed.

PART 2 - PRODUCTS

2.1 CABINET UNIT HEATERS

- A. Available Manufacturers: Subject to compliance with requirements, manufacturers offering products that may be incorporated into the Work include, but are not limited to, the following:
- B. Manufacturers: Subject to compliance with requirements, provide products by one of the following:
- C. Basis-of-Design Product: Subject to compliance with requirements, provide or a comparable product by one of the following:
 - 1. Trane
 - 2. Sterling Hydraunics
- D. Description: A factory-assembled and -tested unit complying with AHRI 440.
 - 1. Comply with UL 2021.
- E. Coil Section Insulation: ASTM C 1071; surfaces exposed to airstream shall be aluminum-foil facing.to prevent erosion of glass fibers.
 - 1. Thickness: 1 inch (25 mm)
 - 2. Thermal Conductivity (k-Value): 0.26 Btu x in./h x sq. ft. at 75 deg F (0.037 W/m x K at 24 deg C) mean temperature.
 - 3. Fire-Hazard Classification: Maximum flame-spread index of 25 and smoke-developed index of 50 when tested according to ASTM E 84.
 - 4. Adhesive: Comply with ASTM C 916 and with NFPA 90A or NFPA 90B.
- F. Cabinet: Steel with baked-enamel finish with manufacturer's standard paint, in color selected by Architect
 - 1. Horizontal Unit, Exposed Bottom Panels: Minimum [0.0528-inch- (1.35-mm)] [0.0677-inch (1.7-mm)] thick, galvanized, sheet steel, removable panels secured with tamperproof cam fasteners and safety chain.
 - 2. Recessing Flanges: Steel, finished to match cabinet.
 - 3. Control Access Door: Key operated.
 - 4. Base: Minimum 0.0528-inch (1.35-mm) thick steel, finished to match cabinet, 4 inches (100 mm) high with leveling bolts.

- G. Filters: Minimum arrestance according to ASHRAE 52.1 and a minimum efficiency reporting value (MERV) according to ASHRAE 52.2.
 - 1. Pleated: 90 percent arrestance and 7 MERV.
- H. Hot-Water Coil: Copper tube, with mechanically bonded aluminum fins spaced no closer than 0.1 inch (2.5 mm) and rated for a minimum working pressure of 200 psig (1378 kPa) and a maximum entering-water temperature of 220 deg F (104 deg C). Include manual air vent and drain.
- I. Fan and Motor Board: Removable.
 - 1. Fan: Forward curved, double width, centrifugal; directly connected to motor. Thermoplastic or painted-steel wheels, and aluminum, painted-steel, or galvanized-steel fan scrolls.
 - 2. Motor: Permanently lubricated, multispeed; resiliently mounted on motor board. Comply with requirements in Division 23 Section "Common Motor Requirements for HVAC Equipment."
 - 3. Wiring Terminations: Connect motor to chassis wiring with plug connection.
- J. Control devices and operational sequences are specified in Division 23 Sections "Instrumentation and Control for HVAC" and "Sequence of Operations for HVAC Controls."

2.2 PROPELLER UNIT HEATERS

- A. Available Manufacturers: Subject to compliance with requirements, manufacturers offering products that may be incorporated into the Work include, but are not limited to, the following:
- B. Manufacturers: Subject to compliance with requirements, provide products by one of the following:
 - 1. Trane
 - 2. Berko
 - 3. Chromalox
- C. Description: An assembly including casing, coil, fan, and motor in horizontal discharge configuration with adjustable discharge louvers.
- D. Comply with UL 2021.
- E. Cabinet: Removable panels for maintenance access to controls.
- F. Cabinet Finish: Manufacturer's standard baked enamel applied to factory-assembled and -tested propeller unit heater before shipping.
- G. Discharge Louver: Adjustable fin diffuser for horizontal units and conical diffuser for vertical units.
- H. Electric-Resistance Heating Elements: Nickel-chromium heating wire, free from expansion noise and 60-Hz hum, embedded in magnesium oxide refractory and sealed in steel or corrosion-resistant metallic sheath with fins no closer than 0.16 inch (4 mm). Element ends shall be enclosed in terminal box. Fin surface temperature shall not exceed 550 deg F (288 deg C) at any point during normal operation.
 - 1. Circuit Protection: One-time fuses in terminal box for overcurrent protection and limit controls for high-temperature protection of heaters.
 - 2. Wiring Terminations: Stainless-steel or corrosion-resistant material.

- I. Fan: Propeller type with aluminum wheel directly mounted on motor shaft in the fan venturi.
- J. Fan Motors: Comply with requirements in Division 23 Section "Common Motor Requirements for HVAC Equipment."
 - 1. Motor Type: Permanently lubricated, multispeed
- K. Control Devices:
 - 1. Unit-mounted fan-speed switch.
 - 2. Wall-mounting thermostat.

PART 3 - EXECUTION

3.1 EXAMINATION

- A. Examine areas to receive unit heaters for compliance with requirements for installation tolerances and other conditions affecting performance.
- B. Examine roughing-in for piping and electrical connections to verify actual locations before unit heater installation.
- C. Proceed with installation only after unsatisfactory conditions have been corrected.

3.2 INSTALLATION

- A. Install wall boxes in finished wall assembly; seal and weatherproof. Joint-sealant materials and applications are specified in Division 07 Section "Joint Sealants."
- B. Install cabinet unit heaters to comply with NFPA 90A.
- C. Install propeller unit heaters level and plumb.
- D. Suspend propeller unit heaters from structure with all-thread hanger rods and elastomeric hangers. Hanger rods and attachments to structure are specified in Division 23 Section "Hangers and Supports for HVAC Piping and Equipment." Vibration hangers are specified in Division 23 Section "Vibration and Seismic Controls for HVAC Piping and Equipment."
- E. Install wall-mounting thermostats and switch controls in electrical outlet boxes at heights to match lighting controls. Verify location of thermostats and other exposed control sensors with Drawings and room details before installation.
- F. Install new filters in each fan-coil unit within two weeks of Substantial Completion.

3.3 CONNECTIONS

- A. Piping installation requirements are specified in other Division 23 Sections. Drawings indicate general arrangement of piping, fittings, and specialties.
- B. Install piping adjacent to machine to allow service and maintenance.
- C. Connect piping to cabinet unit heater's factory, hot-water piping package. Install the piping package if shipped loose.
- D. Connect supply and return ducts to cabinet unit heaters with flexible duct connectors specified in Division 23 Section "Air Duct Accessories."
- E. Comply with safety requirements in UL 1995.

- F. Unless otherwise indicated, install union and gate or ball valve on supply-water connection and union and calibrated balancing valve on return-water connection of unit heater. Hydronic specialties are specified in Division 23 Section "Hydronic Piping."
- G. Ground equipment according to Division 26 Section "Grounding and Bonding for Electrical Systems."
- H. Connect wiring according to Division 26 Section "Low-Voltage Electrical Power Conductors and Cables."

3.4 FIELD QUALITY CONTROL

- A. Perform the following field tests and inspections and prepare test reports:
 - 1. Operational Test: After electrical circuitry has been energized, start units to confirm proper motor rotation and unit operation.
 - 2. Operate electric heating elements through each stage to verify proper operation and electrical connections.
 - 3. Test and adjust controls and safety devices. Replace damaged and malfunctioning controls and equipment.
- B. Remove and replace malfunctioning units and retest as specified above.

3.5 ADJUSTING

- A. Adjust initial temperature set points.

END OF SECTION

SECTION 23 83 16

HYDRONIC RADIANT SNOW MELT SYSTEM

PART 1 - GENERAL

1.1 RELATED DOCUMENTS

- A. Drawings and general provisions of the Contract, including General and Supplementary Conditions and Division 01 Specification Sections, apply to this Section.
- B. Section 01 81 13 "Sustainable Design Requirements – LEED v4 for Building Design & Construction – New Construction" for sustainable design requirements and detailed sustainable design submittal requirements.
- C. Section 01 74 19 "Construction and Demolition Waste Management and Disposal" for disposal of construction, demolition and packaging waste disposal requirements.

1.2 SUMMARY

- A. The work covered by this section includes materials required to supply, install and pressure test Engel Method cross-linked polyethylene (PEX-A as shown on drawings or as specified herein. The radiant snow melt system shall include, but not limited to, all piping, manifolds, valves, pumps, pressure relief valves, and controls to provide a complete and operational heating system. The applicable installation method(s) shall comply with published installation instructions from the tubing manufacturer.
- B. Sustainable Building Requirements:
 - 1. The Owner requires the Contractor to implement practices and procedures to meet the project's environmental performance goals, which include achieving LEED version 4 **Certified** level Certification. Specific project goals that may impact this area of work include: use of recycled-content materials; use of locally-manufactured materials; use of low-emitting materials; construction waste recycling; and the implementation of a construction indoor air quality management plan. The Contractor shall ensure that the requirements related to these goals, as defined in the Articles below, are implemented to the fullest extent. Substitutions, or other changes to the work proposed by the Contractor or their Subcontractors, shall not be allowed if such changes compromise the aforementioned environmental goals and LEED certification.

1.3 DEFINITIONS

- A. EPDM: Ethylene-propylene-diene terpolymer rubber.
- B. PEX: Crosslinked polyethylene.
- C. PEX/AL/PEX: Crosslinked polyethylene/aluminum/crosslinked polyethylene.

1.4 SUBMITTALS

- A. Product Data: For each type of radiant heating pipe, fitting, manifold, specialty and control.
 - 1. For radiant snow melt piping and manifolds, include pressure and temperature rating, oxygen-barrier performance, fire-performance characteristics, and water flow and pressure drop characteristics.
- B. Shop Drawings:
 - 1. Provide installation drawings indicating tubing layout, manifold locations, zoning requirements and manifold schedules with details required for installation of the system
 - 2. Provide mechanical schematic indicating heat source, mechanical piping and accessories from heat source to manifolds, circulators, water tempering and zone controls. Indicate supply water temperatures and flow rates to manifolds.
 - 3. Layout Drawing Scale: 1/4 inch = 1 foot.
- C. Operation and Maintenance Data: For radiant snow melt piping valves and equipment to include in operation and maintenance manuals.
- D. Quality Assurance and Control Submittals: Submit the following.
 - 1. Test Reports: Upon request, submit test reports from recognized testing laboratories.
 - 2. Documentation: Submit the following.
 - a. Manufacturer's certificate indicating products comply with specified requirements
 - b. Manufacturer's detailed heat-loss analysis for the snow melt system.
 - c. Documentation indicating the installer is trained to install the manufacturer's products
- E. Closeout Submittals: Submit the following.
 - 1. Warranty documents specified herein
 - 2. Operation and maintenance data
 - 3. Manufacturer's field reports specified herein
 - 4. Final as-built tubing layout drawing

1.5 QUALITY ASSURANCE

- A. Installer Qualifications: Use an installer with demonstrated experience on projects of similar size and complexity and possessing documentation proving successful completion of radiant floor heating or snow melt training by the PEX tubing manufacturer.
- B. Certifications: Provide letters of certification as follows.
 - 1. Installer is trained by the PEX tubing manufacturer to install radiant floor heating or snow melt systems.
 - 2. Installer uses skilled workers holding a trade qualification license or equivalent, or apprentices under the supervision of a licensed tradesperson.
- C. Pre-installation Meetings
 - 1. Verify project requirements, substrate conditions, floor coverings, manufacturer's installation instructions and warranty requirements.
 - 2. Review project construction timeline to ensure compliance or discuss modifications as required.
 - 3. Interface with other trade representatives to verify areas of responsibility.

4. Establish the frequency and construction phase the project engineer intends for site visits and inspections by the PEX tubing manufacturer's representative.

1.6 DELIVERY, STORAGE AND HANDLING

- A. General: Comply with Division 1 Product Requirements Section.
- B. Comply with manufacturer's ordering instructions and lead-time requirements to avoid construction delays.
- C. Delivery: Deliver materials in manufacturer's original, unopened, undamaged containers with identification labels intact.
- D. Storage and Protection: Store materials protected from exposure to harmful environmental conditions and at temperature and humidity conditions recommended by the manufacturer.
 1. Store PEX tubing in cartons or under cover to avoid dirt or foreign material from entering the tubing.
 2. Do not expose PEX tubing to direct sunlight for more than 30 days. If construction delays are encountered, cover the tubing that is exposed to direct sunlight.

1.7 WARRANTY

- A. Project Warranty: Refer to Conditions of the Contract for project warranty provisions.
- B. Manufacturer's Warranty: Submit, for Owner's acceptance, manufacturer's standard warranty document executed by authorized company official. Manufacturer's warranty is in addition to, and not a limitation of, other rights Owner may have under contract documents.
 1. Warranty covers the repair or replacement of any tubing or fittings proven defective.
 2. Warranty may transfer to subsequent owners.
 3. Warranty Period for PEX Tubing: 30-year, non-prorated warranty against failure due to defect in material or workmanship, beginning with date of substantial completion.
 4. Warranty Period for Manifolds and Fittings: 5-year, non-prorated warranty against failure due to defect in material or workmanship, beginning with date of substantial completion.
 5. Warranty Period for Controls and Electrical Components: 2-year, non-prorated warranty against failure due to defect in material or workmanship, beginning with date of substantial completion.

1.8 OWNER'S TRAINING

- A. Instruct Owner's personnel about operation and maintenance of installed system. Provide manufacturer's installation, operation and maintenance instructions for installed components within the system.

PART 2 - PRODUCTS

2.1 PEX PIPE AND FITTINGS

- A. Manufacturers: Subject to compliance with requirements, provide products by one of the following:
 - 1. Viega
 - 2. Uponor Wirsbo Co.
- B. Pipe Material: PEX plastic according to ASTM F 876.
- C. Oxygen Barrier: Limit oxygen diffusion through the tube to maximum 0.10 mg per cu. m/day at 104 deg F (40 deg C) according to DIN 4726.
- D. Fittings: ASTM F 1807, metal insert and copper crimp rings.
- E. Pressure/Temperature Rating: Minimum 100 psig (690 kPa) and 180 deg F (82 deg C).

2.2 DISTRIBUTION MANIFOLDS

- A. Manifold: Minimum NPS 2 INCH, copper.
- B. Main Shutoff Valves:
 - 1. Factory installed on supply and return connections.
 - 2. Two-piece body.
 - 3. Body: Brass or bronze.
 - 4. Ball: Chrome-plated bronze.
 - 5. Seals: PTFE.
 - 6. CWP Rating: 150 psig (1035 kPa).
 - 7. Maximum Operating Temperature: 225 deg F (107 deg C).
- C. Manual Air Vents:
 - 1. Body: Bronze.
 - 2. Internal Parts: Nonferrous.
 - 3. Operator: Key furnished with valve, or screwdriver bit.
 - 4. Inlet Connection: NPS 1/2 (DN 15).
 - 5. Discharge Connection: NPS 1/8 (DN 6).
 - 6. CWP Rating: 150 psig (1035 kPa).
 - 7. Maximum Operating Temperature: 225 deg F (107 deg C).
- D. Balancing Valves:
 - 1. Body: Plastic or bronze, ball or plug, or globe cartridge type.
 - 2. Ball or Plug: Brass or stainless steel.
 - 3. Globe Cartridge and Washer: Brass with EPDM composition washer.
 - 4. Seat: PTFE.
 - 5. Differential Pressure Gage Connections: Integral seals for portable meter to measure loss across calibrated orifice.
 - 6. Handle Style: Lever or knob, with memory stop to retain set position if used for shutoff.
 - 7. CWP Rating: Minimum 125 psig (860 kPa).
 - 8. Maximum Operating Temperature: 250 deg F (121 deg C).
- E. Zone Control Valves:
 - 1. Body: Plastic or bronze, ball or plug, or globe cartridge type.
 - 2. Ball or Plug: Brass or stainless steel.

3. Globe Cartridge and Washer: Brass with EPDM composition washer.
4. Seat: PTFE.
5. Actuator: Replaceable electric motor.
6. CWP Rating: Minimum 125 psig (860 kPa).
7. Maximum Operating Temperature: 250 deg F (121 deg C).

F. Thermometers:

1. Mount on supply and return connections.
2. Case: Dry type, metal or plastic, 2-inch (50-mm) diameter.
3. Element: Bourdon tube or other type of pressure element.
4. Movement: Mechanical, connecting element and pointer.
5. Dial: Satin-faced, nonreflective aluminum with permanently etched scale markings.
6. Pointer: Black metal.
7. Window: Plastic.
8. Connector: Rigid, back type.
9. Thermal System: Liquid- or mercury-filled bulb in copper-plated steel, aluminum, or brass stem.
10. Accuracy: Plus or minus 1 percent of range or plus or minus 1 scale division to maximum of 1.5 percent of range.

- G. Mounting Brackets: Copper, or plastic or copper-clad steel, where in contact with manifold.

2.3 PIPING SPECIALTIES

A. Cable Ties:

1. Fungus-inert, self-extinguishing, 1-piece, self-locking, Type 6/6 nylon cable ties.
2. Minimum Width: 1/8 inch (3 mm).
3. Tensile Strength: 20 lb (9 kg), minimum.
4. Temperature Range: Minus 40 to plus 185 deg F (Minus 40 to plus 85 deg C).

2.4 CONTROLS

A. Supply Fluid Temperature Control (automatic control strategy)

1. Temper the supply fluid temperature to the snow and ice melt panel by means of a variable speed injection pump controlled by the Uponor SNOWpro™ 411, or an approved equal.
2. The snow melt controller shall have the ability to reset the supply fluid temperature as it relates to outdoor temperature. Install the outdoor temperature sensor (S4) on the north face of the building out of direct sunlight.
3. Run time shall be programmed by the snow melt controller for between 30 minutes to 17 hours or infinity. The control operates in snow-melt mode as long as there is moisture present on the sensor.
4. Provide one snow and ice detector per well (total of 3) to monitor the presence of moisture on the sensor (snow-melt mode) and slab temperature.
5. The snow melt controller shall have the ability to idle the snow-melt slab at a given temperature and automatically accelerates to a higher slab temperature during snow-melting mode.

- a. The snow melt controller will automatically switch from snow-melt mode to idle mode once the snow and ice detector indicates the lack of moisture on the sensor.
6. When there is a call for snow melt, the snow melt controller shall:
 - a. Activate the variable speed injection pump (P4)
 - b. Initiate the heat exchanger

PART 3 - EXECUTION

3.1 EXAMINATION

- A. Examine surfaces and substrates to receive radiant snow melt piping for compliance with requirements for installation tolerances and other conditions affecting performance.
 1. Ensure that surfaces and pipes in contact with radiant snow melt piping are free of burrs and sharp protrusions.
 2. Ensure that surfaces and substrates are level and plumb.
 3. Proceed with installation only after unsatisfactory conditions have been corrected.

3.2 INSTALLATION

- A. Drawing plans, schematics, and diagrams indicate general location and arrangement of piping systems. Indicate piping locations and arrangements if such were used to size pipe and calculate friction loss, expansion, pump sizing, and other design considerations. Install piping as indicated unless deviations to layout are approved on Shop or Coordination Drawings.
- B. Install radiant snow melt piping continuous from the manifold through the heated panel and back to the manifold without piping joints in heated panels.
- C. Connect radiant piping to manifold in a reverse-return arrangement.
- D. Do not bend pipes in radii smaller than manufacturer's minimum bend radius dimensions.
- E. Install manifolds in accessible locations, or install access panels to provide maintenance access as required in Division 08 Section "Access Doors and Frames."
- F. Refer to Division 23 Section "Hydronic Piping" for pipes and connections to hydronic systems and for glycol-solution fill requirements.
- G. Fire- and Smoke-Barrier Penetrations: Maintain indicated fire rating of walls, partitions, ceilings, and floors at pipe penetrations. Seal pipe penetrations with firestop materials according to Division 07 Section "Penetration Firestopping."
- H. Piping in Slab Over Existing Slab Construction with Edge and Under-slab Insulation
 1. Provide 2 inch thick high-density foam insulation board, install the tubing by stapling the tubing to the insulation board with Foam Staples.
 2. Install the vertical edge insulation along the perimeter of the slab and down to a depth equal to the bottom of the horizontal under-slab insulation.
 3. Refer to the snow melt schedule for the tubing on-center distance(s) and loop lengths.
 4. Do not install tubing closer than 6 inches (152mm) from the edge of the heated slab.

5. Install the tubing at a consistent depth below the surface elevation as determined by the project engineer. Tubing installation will ensure sufficient clearance for all control joint cuts.
 6. Fibrous expansion joints may be penetrated following the PEX tubing manufacturer's and structural engineer's recommendation.
 7. Metal or plastic bend supports will be used to support the tubing when departing from the slab in a 90 degree bend.
- I. Slab Sensor:
 1. Install slab sensor and wire in 3/4 inch PEX tubing conduit embedded in the concrete floor slab. Extend conduit out of floor slab to allow for sensor replacement.
 2. Install sensor equally spaced between radiant tubing with a 1 inch minimum cover.
 - J. Revise locations and elevations from those indicated as required to suit field conditions and ensure integrity of piping and as approved by Architect.
 - K. After system balancing has been completed, mark balancing valves to permanently indicate final position.
 - L. Perform the following adjustments before operating the system:
 1. Open valves to fully open position.
 2. Check operation of automatic valves.
 3. Set temperature controls so all zones call for full flow.
 4. Purge air from piping.
 - M. After the concrete floor has cured as recommended by concrete supplier, operate radiant heating system as follows:
 1. Start system heating at a maximum of 10 deg F (6 deg C) above the ambient floor temperature, and increase 10 deg F (6 deg C) each following day until design temperature is achieved.
- ### 3.3 FIELD QUALITY CONTROL
- A. Tests and Inspections:
 1. Leak Test: After installation, charge system and test for leaks. Subject piping to hydrostatic test pressure that is not less than 1.5 times the design pressure but not more than 100 psig (690 kPa). Repair leaks and retest until no leaks exist.
 2. Test and adjust controls and safeties. Replace damaged and malfunctioning controls and equipment.
 - B. Remove and replace malfunctioning radiant heating piping components that do not pass tests, and retest as specified above.
 - C. Prepare a written report of testing.

END OF SECTION

This page is intentionally left blank.

SECTION 23 83 23

RADIANT-HEATING PANELS

PART 1 - GENERAL

1.1 RELATED DOCUMENTS

- A. Drawings and general provisions of the Contract, including General and Supplementary Conditions and Division 01 Specification Sections, apply to this Section.
- B. Section 01 81 13 "Sustainable Design Requirements – LEED v4 for Building Design & Construction – New Construction" for sustainable design requirements and detailed sustainable design submittal requirements.
- C. Section 01 74 19 "Construction and Demolition Waste Management and Disposal" for disposal of construction, demolition and packaging waste disposal requirements.

1.2 SUMMARY

- A. This Section includes prefabricated radiant-heating hot water panels.
- B. Sustainable Building Requirements:
 - 1. The Owner requires the Contractor to implement practices and procedures to meet the project's environmental performance goals, which include achieving LEED version 4 **Certified** level Certification. Specific project goals that may impact this area of work include: use of recycled-content materials; use of locally-manufactured materials; use of low-emitting materials; construction waste recycling; and the implementation of a construction indoor air quality management plan. The Contractor shall ensure that the requirements related to these goals, as defined in the Articles below, are implemented to the fullest extent. Substitutions, or other changes to the work proposed by the Contractor or their Subcontractors, shall not be allowed if such changes compromise the aforementioned environmental goals and LEED certification.

1.3 SUBMITTALS

- A. Product Data: Include rated capacities, operating characteristics, furnished specialties, and accessories for each type of product indicated.
- B. Shop Drawings: For radiant heating panels. Include plans, sections, details, and attachments to other work.
- C. Coordination Drawings: Reflected ceiling plans, drawn to scale, on which the following items are shown and coordinated with each other, based on input from installers of the items involved:
 - 1. Ceiling suspension assembly members.
 - 2. Method of attaching hangers to building structure.

3. Structural members to which heating panels and suspension systems will be attached.
 4. Size and location of initial access modules for acoustical tile.
 5. Items installed in finished ceiling, including the following:
 - a. Lighting fixtures.
 - b. Air outlets and inlets.
 - c. Speakers.
 - d. Sprinklers.
 - e. Access panels.
 - f. Perimeter moldings.
- D. Field quality-control test reports.

1.4 COORDINATION

- A. Coordinate layout and installation of radiant panels and suspension system components with other construction that penetrates ceilings or is supported by them, including light fixtures, HVAC equipment, fire-suppression system, and partition assemblies.

PART 2 - PRODUCTS

2.1 RADIANT HOT WATER PANELS

- A. General
1. Provide a radiant heating panel system as indicated on the drawings and connect to hot water piping.
 2. Acceptable manufacturers subject to compliance with the specifications shall be as follows:
 - a. Aero Tech
 - b. Sun-EI
 - c. Sterling
 - d. Airtex
 - e. Rosemex
 - f. Airtite
 3. Performance data and dimensional specifications shall be available from the manufacturer for all products. Performance and capacity data shall be based on testing performed by the manufacturer and confirmed by a testing laboratory recognized in the Industry.
- B. Radiant Panels/Extrusions
1. Radiant panel shall be manufactured utilizing extruded aluminum strips of approximately 0.115 overall thickness. The strips shall have a minimum 0.495 I.D. copper tube firmly attached to aluminum extrusion under all operating temperature conditions. Ends of tubes shall be swaged to 0.569 I.D. for proper soldering fit of ½ inch Type "L" soft copper tubing.
 2. Panel sizes shall fit into a ceiling inverted T-bar linear system and as called for in the drawings and specifications. Lengths shall be as shown on the

- drawings. Finish on the face of the panel shall be of a color selected by the Architect. Finish shall be powder coated and suitable for temperatures up to 350°F.
3. Face configuration shall be fluted, with recessed 1/8 inch linear flutes on 1/2 inch centers.
 4. Circuiting of the tubes on the back of the panel shall be straight tubes with ends slightly pulled up for ease of soldering.
 5. Panel thermal performance shall be as specified on the mechanical drawings.
 6. The panel manufacturer shall provide a 2 inch thick glass fiber pad insulation on the upper side of the radiant panels to minimize heat loss to the ceiling plenum.
 7. Insulation shall be attached to the panel.

PART 3 - EXECUTION

3.1 EXAMINATION

- A. Examine surfaces and substrates to receive electric heating panels for compliance with requirements for installation tolerances and other conditions affecting performance.
 1. Ensure surfaces and substrates are level and plumb.
 2. Proceed with installation only after unsatisfactory conditions have been corrected.

3.2 INSTALLATION

- A. Install radiant-heating panels level and plumb.
- B. Support for Radiant-Heating Panels in or on Grid-Type Suspended Ceilings: Use grid as a support element.
 1. Install a minimum of four ceiling support system rods or wires for each panel. Locate not more than 6 inches (150 mm) from panel corners.
 2. Support Clips: Fasten to panel and to ceiling grid members at or near each panel corner with clips designed for the application.
 3. Panels of Sizes Less Than Ceiling Grid: Install as indicated on reflected ceiling plans or center in acoustical panel, and support panels independently with at least two 3/4-inch (19-mm) metal channels spanning and secured to ceiling tees.
 4. Install at least one independent support rod or wire from structure to a tab on panel. Wire or rod shall have breaking strength of the weight of panel at a safety factor of 3.
- C. Verify locations of thermostats with Drawings and room details before installation. Install devices 48 inches (1220 mm) above finished floor.

3.3 CLEANING

- A. After construction is completed, including painting, clean exposed surfaces of units.
- B. Touch-up marred or scratched surfaces of factory-finished cabinets, using finish materials furnished by manufacturer.

END OF SECTION

This page is intentionally left blank.

SECTION 23 84 13

HUMIDIFIERS

PART 1 - GENERAL

1.1 RELATED DOCUMENTS

- A. Drawings and general provisions of the Contract, including General and Supplementary Conditions and Division 01 Specification Sections, apply to this Section.
- B. Section 01 81 13 "Sustainable Design Requirements – LEED v4 for Building Design & Construction – New Construction" for sustainable design requirements and detailed sustainable design submittal requirements.
- C. Section 01 74 19 "Construction and Demolition Waste Management and Disposal" for disposal of construction, demolition and packaging waste disposal requirements.

1.2 SUMMARY

- A. This Section includes the following humidifiers:
 - 1. Steam injection.
- B. Sustainable Building Requirements:
 - 1. The Owner requires the Contractor to implement practices and procedures to meet the project's environmental performance goals, which include achieving LEED version 4 **Certified** level Certification. Specific project goals that may impact this area of work include: use of recycled-content materials; use of locally-manufactured materials; use of low-emitting materials; construction waste recycling; and the implementation of a construction indoor air quality management plan. The Contractor shall ensure that the requirements related to these goals, as defined in the Articles below, are implemented to the fullest extent. Substitutions, or other changes to the work proposed by the Contractor or their Subcontractors, shall not be allowed if such changes compromise the aforementioned environmental goals and LEED certification.

1.3 DEFINITION

- A. Low Voltage: As defined in NFPA 70 for circuits and equipment operating at less than 50 V or for remote-control, signaling power-limited circuits.

1.4 SUBMITTALS

- A. Product Data: Include rated capacities, operating characteristics, furnished specialties, and accessories.
- B. Shop Drawings: Detail fabrication and installation of humidifiers. Include piping details, plans, elevations, sections, details of components, manifolds, and attachments to other work.
 - 1. Wiring Diagrams: Power, signal, and control wiring.

- C. Coordination Drawings: Detail humidifiers and adjacent equipment. Show support locations, type of support, weight on each support, required clearances, and other details, drawn to scale, on which the following items are shown and coordinated with each other, based on input from installers of the items involved.
- D. Field quality-control test reports.
- E. Operation and Maintenance Data: For humidifiers to include in operation and maintenance manuals.

1.5 QUALITY ASSURANCE

- A. Electrical Components, Devices, and Accessories: Listed and labeled as defined in NFPA 70, Article 100, by a testing agency acceptable to authorities having jurisdiction, and marked for intended use.
- B. Comply with ARI 640, "Commercial and Industrial Humidifiers."

1.6 COORDINATION

- A. Coordinate location and installation of humidifiers with manifolds in ducts and air-handling units or occupied space. Revise locations and elevations to suit field conditions and to ensure proper humidifier operation.

PART 2 - PRODUCTS

2.1 STEAM-INJECTION HUMIDIFIERS

- A. Manufacturers: Subject to compliance with requirements, provide products by one of the following:
 - 1. DRI-STEEM Humidifier Company.
- B. The steam dispersion panel shall directly inject pressurized boiler steam or evaporative, non-pressurized steam into ducted air for humidification. The factory-assembled steam dispersion panel shall include the following components:
 - 1. Steam supply header/separator
 - 2. Condensate collection header
 - 3. Closely-spaced steam dispersion tubes spanning the distance between the two headers
- C. Each dispersion tube shall be fitted with two rows of steam discharge tubelets inserted into the tube wall, centered on the diametric line, and spaced 1.5" (38 mm) apart. Each tubelet shall be made of a thermal-resin material designed for high steam temperatures. The two rows of tubelets in each dispersion tube shall discharge steam in diametrically opposite directions, perpendicular to airflow.
- D. Each tubelet shall extend through the wall of and into the center of the dispersion tube and contain a steam orifice sized for its required steam capacity.
- E. All tubes and headers shall be 304 stainless steel, and joints shall be Heli-arc welded. Casing shall be 304 stainless steel.
- F. Steam valve and actuator: Valve shall be a normally closed modulating type with modified linear flow. Valve trim shall be stainless steel and valve maximum flow rate shall not exceed specified humidifier capacity by more than 20%. Actuator

shall be a electric type to modulate the steam valve in response to a variable signal demand and be direct acting.

- G. Steam trap(s): Humidifier shall have one or two float/thermostatic trap(s) for applications equal to or below 15 psi steam, or one or two inverted bucket steam trap(s) for applications above 15 psi steam.
- H. Dispersion tubes shall be insulated with a plenum–approved insulating material for in–duct installation and have an R–value not less than 0.5 at a thickness not more than 0.125" (3.2 mm), for minimal increase in dispersion tube diameter.
- I. HUMIDIFIER CONTROL OPTIONS
 - 1. Control input accessory options:
 - 2. Humidistat, electronic, room: Electronic humidistat shall be room–mounted and produce a modulated DC signal output, field–selectable 0 to 10 VDC or 6 to 9 VDC with control action field–selectable to be direct or reverse acting. Set point range 20% to 80% RH, supply voltage 24 DC or 24 AC. Maximum ambient temperature 122 °F (50 °C).
 - 3. Airflow proving switch, sail type: Airflow proving switch shall be a sail–operated electric switch for field installation. Switch makes at 250 fpm (1.3 m/s), and breaks at 75 fpm (0.4 m/s). Maximum operating temperature for sail: 170 °F (77 °C). Maximum operating temperature for switch: 125 °F (52 °C)

PART 3 - EXECUTION

3.1 EXAMINATION

- A. Examine ducts, air-handling units, and conditions for compliance with requirements for installation tolerances and other conditions affecting performance.
- B. Examine roughing-in for piping systems to verify actual locations of piping connections before humidifier installation.
- C. Proceed with installation only after unsatisfactory conditions have been corrected.

3.2 INSTALLATION

- A. Install humidifiers with required clearance for service and maintenance.
- B. Seal humidifier manifold duct or plenum penetrations with flange.
- C. Install humidifier manifolds in metal ducts and casings constructed according to SMACNA's "HVAC Duct Construction Standards, Metal and Flexible."
- D. Install manifold supply piping pitched to drain condensate back to humidifier.
- E. Install drip leg upstream from steam trap a minimum of 12 inches tall for proper operation of trap.

3.3 CONNECTIONS

- A. Piping installation requirements are specified in other Division 23 Sections. Drawings indicate general arrangement of piping, fittings, and specialties.
 - 1. Install piping adjacent to humidifiers to allow service and maintenance.

TABLE OF CONTENTS
ELECTRICAL

SECTION NUMBER	SECTION TITLE
26 00 00	GENERAL PROVISIONS FOR ELECTRICAL WORK
26 00 01	SUPPLEMENTARY CONDITIONS FOR MECHANICAL, ELECTRICAL, PLUMBING AND FIRE PROTECTION WORK
26 05 00	COMMON WORK RESULTS FOR ELECTRICAL
26 05 19	LOW-VOLTAGE ELECTRICAL POWER CONDUCTORS AND CABLES
26 05 26	GROUNDING AND BONDING FOR ELECTRICAL SYSTEMS
26 05 29	HANGERS AND SUPPORTS FOR ELECTRICAL SYSTEMS
26 05 33	RACEWAY AND BOXES FOR ELECTRICAL SYSTEMS
26 05 53	IDENTIFICATION FOR ELECTRICAL SYSTEMS
26 05 73	OVERCURRENT PROTECTIVE DEVICE COORDINATION STUDY
26 09 23	LIGHTING CONTROL DEVICES
26 22 00	LOW-VOLTAGE TRANSFORMERS
26 24 16	PANELBOARDS
26 27 26	WIRING DEVICES
26 28 16	ENCLOSED SWITCHES AND CIRCUIT BREAKERS
26 41 13	LIGHTNING PROTECTION SYSTEM
26 51 00	INTERIOR LIGHTING
28 31 11	FIRE ALARM EXTENSION
28 31 11.11	BI-DIRECTIONAL ANTENNA SYSTEM
28 41 11	AREA OF RESCUE ASSISTANCE INTERCOM SYSTEM

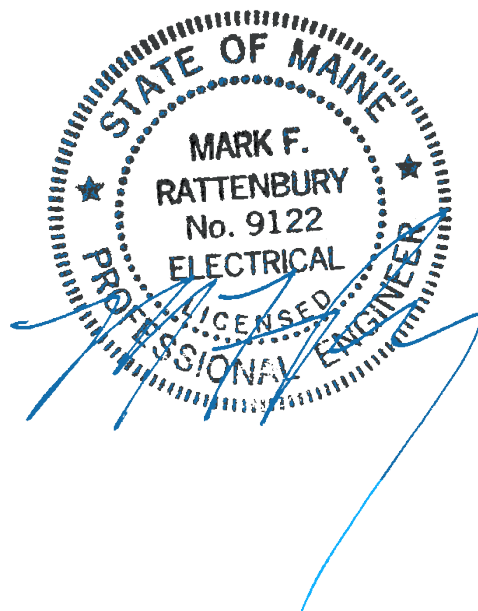

This page is intentionally left blank.

- B. Install electrical devices and piping specialties furnished by manufacturer but not factory mounted.

3.4 FIELD QUALITY CONTROL

- A. Manufacturer's Field Service: Engage a factory-authorized service representative to inspect, test, and adjust components, assemblies, and equipment installations, including connections. Report results in writing.
- B. Perform tests and inspections and prepare test reports.
 - 1. Manufacturer's Field Service: Engage a factory-authorized service representative to inspect components, assemblies, and equipment installations, including connections, and to assist in testing.
- C. Tests and Inspections:
 - 1. Leak Test: After installation, charge system and test for leaks. Repair leaks and retest until no leaks exist.
 - 2. Operational Test: After electrical circuitry has been energized, start units to confirm proper motor rotation and unit operation.
 - 3. Test and adjust controls and safeties. Replace damaged and malfunctioning controls and equipment.
- D. Remove and replace malfunctioning units and retest as specified above.

3.5 DEMONSTRATION

- A. Engage a factory-authorized service representative to train Owner's maintenance personnel to adjust, operate, and maintain humidifiers. Refer to Division 01 Section "Demonstration and Training."

END OF SECTION

SECTION 26 00 00

GENERAL PROVISIONS FOR ELECTRICAL WORK

PART 1 - GENERAL

1.1 RELATED DOCUMENTS

- A. The Contractor, Subcontractors, and/or suppliers providing goods or services referenced in or related to this Section shall also be bound by the Documents identified in Division 01 Section "Summary", Paragraph 1.01A, entitled "Related Documents."
- B. Section 01 81 13 "Sustainable Design Requirements – LEED v4 for Building Design & Construction – New Construction" for sustainable design requirements and detailed sustainable design submittal requirements.
- C. Section 01 74 19 "Construction and Demolition Waste Management and Disposal" for disposal of construction, demolition and packaging waste disposal requirements.

1.2 WORK INCLUDED

- A. Work in this Section includes the providing of labor, materials, equipment and services necessary for a complete and safe installation in accordance with the contract documents and all applicable codes and authorities having jurisdiction for the following:
 - 1. Electrical work covered by all Sections within DIVISION 16 of the Specifications, including, but not limited to electrical systems and equipment.
 - 2. RACEWAY
 - 3. WIRE AND CABLE
 - 4. LOW VOLTAGE DISTRIBUTION EQUIPMENT
 - 5. GROUNDING SYSTEM
 - 6. DEVICES
 - 7. LIGHTING FIXTURES
 - 8. TELEPHONE CONDUIT SYSTEM
 - 9. ELECTRICAL PROVISIONS FOR SECURITY AND BUILDING AUTOMATION SYSTEMS
 - 10. FIRE ALARM SYSTEM
 - 11. TESTING
 - 12. UNIT PRICES
 - 13. ALTERNATE PRICES
 - 14. ALLOWANCES
- B. Provide cutting and patching, except as noted in "AIA document A201" and "Supplementary Condition for Mechanical and Electrical Work".
- C. Related Work and Requirements
 - 1. Requirements of GENERAL CONDITIONS and Division No. 1.
 - 2. Requirements noted under HVAC, Plumbing, Fire Protection, Transportation and Automated Monitoring & Control Division of Work.

D. Sustainable Building Requirements:

1. The Owner requires the Contractor to implement practices and procedures to meet the project's environmental performance goals, which include achieving LEED version 4 Certified level Certification. Specific project goals that may impact this area of work include: use of recycled-content materials; use of locally-manufactured materials; use of low-emitting materials; construction waste recycling; and the implementation of a construction indoor air quality management plan. The Contractor shall ensure that the requirements related to these goals, as defined in the Articles below, are implemented to the fullest extent. Substitutions, or other changes to the work proposed by the Contractor or their Subcontractors, shall not be allowed if such changes compromise the aforementioned environmental goals and LEED certification.

1.3 WORK NOT INCLUDED:

- A. Providing temporary light and power.
- B. Providing finished painting.
- C. Providing access doors and filler.
- D. Installing access doors and providing filler.
- E. Cutting and patching, except as noted in "AIA Document A210" and "Supplementary Conditions for Mechanical and Electrical Work."
- F. Supplying and setting motors.
- G. Excavating and backfilling under building.
- H. Excavating and backfilling.

1.4 DESCRIPTION OF BID DOCUMENTS

- A. Specifications describe quality and character of materials and equipment.
- B. Drawings are diagrammatic and indicate general arrangement of systems and work. Follow drawings in laying out work and check drawings of other trades to verify space conditions. Maintain headroom and space conditions.
- C. Scaled and figured dimensions are approximate and are for estimate purposes only. Before proceeding with work, check and verify all dimensions.
- D. Make adjustments that may be necessary or requested in order to resolve space problems, preserve headroom, and avoid architectural openings, structural members and work of other trades.
- E. Typical details, where shown on the drawings, apply to each item of the project where such items are applicable. Typical details are not repeated on the plans.
- F. If Specifications or Drawings appear unclear or contradictory, consult the Architect and/or Engineer for interpretation as early as possible during bidding period. Do not proceed with work without Architect's and/or Engineer's decision.

1.5 DEFINITIONS

- A. "Provide": to supply, install, and make complete, safe, and operable, the particular work referred to unless specifically indicated otherwise.

- B. "Install": to erect, mount, and make complete with all related accessories.
- C. "Furnish" or "supply": to purchase, procure, acquire, and deliver complete with related accessories.
- D. "Work": labor, materials, equipment, services, and all related accessories necessary for the proper and complete installation of complete systems.
- E. "Piping": pipe, tube, fittings, flanges, valves, controls, strainers, hangers, supports, unions, traps, drains, insulation and all related accessories.
- F. "Wiring": raceway, fittings, wire, boxes and all related accessories.
- G. "Concealed": not in view, installed in masonry or other construction, within furred spaces, double partitions, hung ceilings, trenches, crawl spaces, or enclosures.
- H. "Exposed": in view, not installed underground or "concealed" as defined above.
- I. "Indicated," "shown," or "noted": as indicated, shown, or noted on drawings or specifications.
- J. "Similar" or "equal": of base bid manufacture, equal in quality materials, weight, size, performance, design, and efficiency of specified product, conforming with "Base Bid Manufacturers."
- K. "Reviewed" "satisfactory," "accepted," or "directed": as reviewed, satisfactory, accepted, or directed by Architect and/or Engineer.
- L. "Motor Controllers": manual or magnetic starters with or without switches, individual pushbuttons or hand-off-automatic (HOA) switches controlling the operation of motors.
- M. "Control or Actuating Devices": automatic sensing and switching devices such as thermostats, pressure, float, flow, operation of equipment.

1.6 QUALITY ASSURANCE

- A. All work shall combine with National Electrical Code and all applicable local codes.
- B. Furnish all materials and equipment new, free from defects and with listings or labels of Underwriter's Laboratories, Inc. or other nationally approved testing laboratory.
- C. All items of a given type shall be the product of the same manufacturer.
- D. All materials and equipment shall be the product of manufacturers regularly engaged in their manufacture.
- E. Current characteristics:
 - 1. Provide the following service:
 - a. 120/208 volt, 3 phase, 4 wire, 60 Hz with grounded neutral.
 - 2. Provide the following distribution:
 - a. 120/208 volt, 3 phase, 4 wire, 60 Hz with grounded 4W distribution.
- F. Equipment ampere ratings shall be for continuous operation in 104°F (40°C) ambient temperature unless otherwise indicated.
- G. Provide the following heights of outlets and verify with Architect and/or Engineer prior to installation:
 - 1. From finished floor to centerline of outlets for:
 - a. Receptacles and telephones:

- 1) Generally 1'-6"
 - 2) Over work benches 3'-6"
 - b. Wall switches:
 - 1) Generally 4'-0"
 - c. Wall fixtures 7'-0"
 - d. Motor controllers 5'-0"
 - e. Fire alarm stations 3'-6"
 - f. Strobe lights 6'-8" or 6 in below ceiling
(whichever is lower)
2. The following are exceptions to specified height of outlets:
- a. At junction of different wall finish materials.
 - b. On molding or break in wall surface.
 - c. In violation of Code.
 - d. As noted or directed.

1.7 JOB CONDITIONS

- A. Inspection of Site Conditions.
- 1. Before starting work, visit the site and examine the conditions under which the work has to be performed. Report in writing any conditions which might adversely affect the work.
- B. Connections to existing work:
- 1. Install new work and connect to existing work with minimum interference to existing facilities.
 - 2. Provide temporary shutdowns of existing services at no additional charges and only with written consent of Owner. Schedule shutdowns not to interfere with normal operation of existing facilities.
 - 3. Alarm and emergency systems shall not be interrupted.
 - 4. Maintain continuous operation of existing facilities as required with necessary temporary connections between new and existing work.
 - 5. Connect new work to existing work in neat and acceptable manner. Restore existing disturbed work to original condition including maintenance of wiring continuity required.
- C. Hazardous locations:
- 1. Provide required material, equipment and installation for hazardous locations.
 - 2. Provide material, equipment, and installation as required for Class, Division and Group noted.
 - 3. Provide material, equipment, and installation meeting requirements of National Electric Code Class, Division and Group, except Division 1 requirements apply to Division 2.

1.8 REFERENCE STANDARDS

- A. Published specifications, standards, tests, or recommended methods of trade, industry or governmental organizations apply to work in all sections as noted below:
- 1. NEMA - National Electrical Manufacturers' Association.
 - 2. ANSI - American National Standard Institute.
 - 3. IEEE - Institute of Electrical & Electronics Engineers.
 - 4. NFPA - National Fire Protection Association
 - 5. UL - Underwriter's Laboratories, Inc.

6. OSHA - Occupational Safety and Health Administration Regulations.

1.9 SUBMITTAL

- A. Submit shop drawings and samples in accordance with "AIA Document 201" and "Supplementary Conditions for Mechanical and Electrical Work."
- B. Operating instructions, equipment maintenance manuals and parts lists.
 - 1. Before requesting acceptance of work, submit one set for review by the Architect and/or Engineer.
 - 2. Provide sets of manufacturers' equipment brochures and service manuals consisting of the following:
 - a. Descriptive literature for equipment and components.
 - b. Model number and performance data.
 - c. Installation and operating instructions.
 - d. Maintenance and repair instructions.
 - e. Recommended spare parts lists.
 - 3. Assemble manufacturers' equipment manuals in chronological order following the specifications alpha-numerical system using heavy duty three ring binders.
 - 4. Submit three detailed and simplified one line, color coded wiring diagrams.
 - 5. Submit field test reports.
 - 6. Scale drawings for each dwelling unit type including hearing impaired units, indicating dimensioned layout of receptacles, switches, fire alarm devices, hearing impaired devices, and other devices to indicate compliance with the requirements of the electrical code and the applicable accessibility regulations (MAAB, FHA, etc.) Drawings shall be prepared at a minimum of 1/4 inch = 1 foot and shall be submitted to allow adequate time for review by the design team and owner prior to commencement of electrical work within the dwelling units.

1.10 ELECTRONIC COPIES OF AKF DRAWINGS

- A. Upon award of contract, contractor shall submit list of drawings that they will require. AKF will provide drawings in (.PDF) format only.
- B. If the contractor requires (.dwg) format, after preparation the drawings will be forwarded only upon receipt of signed acceptance of terms form. Permission from the architect must first be obtained for AKF to include the architectural background as reference. The contractor is to obtain the architects latest drawings directly from the architect.
- C. These files are being issued for the convenience of the contractor and the contractor remains responsible for all contract requirements related to the normal shop drawing preparation process.

1.11 SUBMISSIONS:

- A. Provide all coordination drawings and shop drawings in 'AutoCad' format, version compatible with owner. All catalog cuts and submittals to be provided in electronic "PDF" format the architect will forward all submissions to the engineer.
- B. If paper submissions are to be provided the following shall be adhered to.
 - 1. Submissions 11 in. X 17 in. or smaller: If the submission is a catalog cut, then the contractor shall submit one original and one copy. Otherwise, they

- shall submit two copies. The architect will forward the original and one copy (two copies when no original is received) to the engineer. All catalog cuts shall be complete.
2. Submissions larger than 11 in. X 17 in.: submit two copies to the architect. The architect will forward to the engineer.
- C. Indicate on each submission: project name and location, architect and engineer, item identification and approval stamp of prime contractor, subcontractor names and phone numbers, reference to the applicable design drawing or specification article, date and scale.
 - D. The work described in all shop drawing submission shall be carefully checked for all clearances (including those required for maintenance and servicing), field conditions, maintenance of architectural conditions and proper coordination with all trades on the job.
 - E. Each submitted shop drawing is to include a certification that all related job conditions have been checked and verified and that there are no conflicts.
 - F. All shop drawings are to be submitted to allow ample time for checking in advance of field requirements. All submittals to be complete and contain all required and detailed information. Shop drawings with multiple parts shall be submitted as a package.
 - G. If submittals differ from the contract document requirements, make specific mention of such difference in a letter of transmittal, with request for substitution, together with reasons for same.
- 1.12 AS-BUILTS AND EQUIPMENT OPERATION INSTRUCTIONS
- A. Provide all coordination drawings and shop drawings in AutoCad format, version compatible with owner. All catalog cuts and submittals to be provided in electronic "PDF" format the architect will forward all submissions to the engineer.
 - B. On completion and acceptance of work, this contractor shall furnish written instructions, equipment manuals and demonstrate to the owner the proper operation and maintenance of all equipment and apparatus furnished under this contract.
 - C. The contractor shall give one copy of the instructions to the owner and one copy to the engineer.
 - D. Final "as-built" drawings indicating as installed conditions shall be provided to the architect and engineer after completion of the installation.
- 1.13 PRODUCT DELIVERY, HANDLING, AND STORAGE
- A. Ship materials and equipment in crated sections of sizes to permit passing through available space, where required.
 - B. Receive and accept materials and equipment at the site, properly handle, house, and protect them from damage and the weather until installation. Replace equipment damaged in the course of handling without additional charge.
 - C. Arrange for and provide storage space or area at the job site for all materials and equipment to be received and/or installed in this project.

1.14 ACCESSIBILITY

- A. Install all work so that parts requiring periodic inspection, operation, maintenance, and repair are readily accessible. Minor deviations from the drawings may be made to accomplish this, but changes of substantial magnitude shall not be made without written approval.
- B. Install equipment requiring access so as to be freely accessible through access doors.

1.15 CUTTING AND PATCHING:

- A. Provide all carpentry, cutting and patching required for proper installation of material and equipment specified. Do not cut or drill structural members without consent of architect and structural engineer.
- B. All cutting and patching will be performed under General Construction Work, except as noted in "AIA Document A201" and "Supplementary Conditions for Mechanical and Electrical Work."

1.16 PROTECTION OF MATERIALS

- A. Protect from damage, water, dust, etc. all material, equipment and apparatus provided under this trade both in storage and installed.

1.17 GUARANTEE

- A. The Contractor shall furnish a written guarantee to replace or repair promptly and assume responsibility for all expenses incurred for any workmanship and equipment in which defects develop within one year from the date of final certificate for payment and/or from date of actual use of equipment or occupancy of spaces by Owner included under the various parts of the work, whichever date is earlier. This work shall be done as directed by the Owner. This guarantee shall also provide that where defects occur, the Contractor will assume responsibility for all expenses incurred in repairing and replacing work of other trades affected by defects, repairs or replacements in equipment supplied by the Contractor.

1.18 PERMITS AND FEES

- A. The Contractor shall give necessary notice, file drawings and specifications with the department having jurisdiction, obtain permits or licenses necessary to carry out this work and pay all fees therefor. The Contractor shall arrange for inspection and tests of any or all parts of the work if so required by authorities and pay all charges for same. The Contractor shall pay all costs for, and furnish to the Owner before final billing, all certificates necessary as evidence that the work installed conforms with all regulations where they apply to this work.

1.19 INSPECTIONS / TESTING

- A. Independent testing and inspections shall be provided by this contractor who shall hire the inspector or testing agency

PART 2 - PRODUCTS

2.1 BASE BID MANUFACTURERS

- A. Base bid on materials or equipment are specified by name of manufacturer, brand or trade name and catalog reference.
- B. The choice will be optional with bidder where two or more manufacturers are named.
- C. Manufacturers, other than specified, will only be considered if at the time of bid, manufacturers' names and proposed substitutions are named and stated and the difference in base bid is indicated including changes in the cost of all affected work.
- D. Submission of equipment of manufacturers other than specified shall detail equality and difference item by item. Delay in ordering of equipment will not be considered a valid cause for substitution.
- E. The following are base bid manufacturers for items under this Section:
 - 1. Access doors: Karp Associates, Inc., Higgins Mfg. Co., Milcor Steel Co. and Walsh-Spencer Co.
 - 2. Inserts: F and S Mfg. Co., Fee and Mason and Grinnell.

2.2 INSERTS AND SUPPORTS

- A. Inserts:
 - 1. Inserts will be provided under General Construction Work.
 - 2. Provide additional acceptable means of support attachments as required, after review.
 - 3. Provide cutting and patching required to install additional attachments.
- B. Support all electrical work from building construction by providing inserts, beam clamps, steel fishplates (in concrete fill only), and acceptable brackets. Submit all methods for review. Inserts shall be steel slotted type, factory painted.
 - 1. Single rod shall be similar to Grinnell Fig. 281.
 - 2. Multi-rod shall be similar to Fee Mason Series 9000 with end caps and closure strips.
 - 3. Clip form nails flush with inserts.
 - 4. Maximum loading including conduit, contents and covering shall not exceed 75% of rated insert capability.
- C. Provide smooth wall, non-self-drilling internal plug expansion type anchors constructed of AISC 12L14 steel and zinc plated in accordance with Fed. Spec. QQ-A-325 Type 1, Class 3.
- D. Provide trapeze hangers of bolted angles or channels for grouped lines and services.
- E. Provide additional framing where building construction is inadequate. Submit for review.
- F. Do not exceed 1/4 of average values for a specific anchor size using 2000 psig (13,800 kpa) concrete only, for maximum working loads.
- G. Provide spacing and install anchors in accordance with the manufacturer's recommendations.

- H. Provide supports from building construction including inserts, beam clamps steel fishplates (in concrete fill only) cantilever brackets or other means. Submit for review.

2.3 SUPPLEMENTARY STEEL, CHANNELS AND SUPPORTS

- A. Furnish supplementary steel, channels, and supports required for proper installations, mounting, and support of electrical work.
- B. Connect supplementary steel and channels firmly to building construction in an accepted manner.
- C. Determine type and size of supporting channels and supplementary steel. Supplementary steel and channels shall be of sufficient strength and size to allow only a minimum deflection in conformance with manufacturers' requirements of loading.
- D. Install supplementary steel and channels in a neat and workmanlike manner parallel to walls, floors, and ceiling construction.
- E. All supplementary steel, channels and supports shall be submitted to the Structural Engineer for review.

2.4 ACCESS DOORS

- A. Access doors will be provided under General Construction Work.
- B. Supply access doors as required for complete access. Installation shall be under General Construction Work. Minimum size shall be 12 in. x 12 in. Locating and setting will be performed after review.
- C. Provide for access doors as required for complete access. Minimum size shall be 12 in. x 12 in. Locating and setting will be performed after review.
- D. Flush type access doors shall be similar to Karp Type DSC-211 for wall installation, with No. 13 USSG steel doors and trim and No. 15 USSG steel frame, metal wings for keying into construction, concealed hinges and screwdriver operated stainless steel cam lock. Lift off type access door shall be similar to Karp Type DSC-212 where door cannot swing open.
- E. Factory finished white access doors shall be similar to Karp Type DSC-210 in acoustic tile ceilings, with NO. 13 USSG steel frame, No. 16 USSG steel pan door suitable for receiving tile thickness and hinges that are not visible when door is closed. Access doors shall be screwdriver operated, stainless steel cam locks finishing flush with tile with a minimum of (2) per door.
- F. Access doors shall be similar to Karp DSC-210-PL in plaster ceilings, with recess to receive plaster.
- G. Fire rated access doors shall be similar to Karp KRP-150-FR, in accordance with applicable code requirements.
- H. Access doors shall be shop-painted zinc chromate primer.

2.5 ACCESS TILE IDENTIFICATION:

- A. Provide buttons, tabs or markers in removable ceiling tiles to identify location of concealed work. Submit for review.

2.6 GUARDS AND RAILINGS

- A. Guards and railings will be provided under General Construction Work.
- B. Provide guards and railings as indicated and/or as required by OSHA and authorities having jurisdiction.
- C. Provide removable type guards with clearances for motor adjustments, for belt driven and rotating equipment, with No. 18 USSG steel frames and NO. 20 USSG galvanized perforated steel fronts with covered test opening to permit rpm readings without removal. Provide galvanized steel angle or channel supports braced to maintain clearances of moving parts.
- D. Provide removable type railings constructed of 1 1/4 in. pipe and rail fittings.

2.7 NAMEPLATES:

- A. Provide nameplates with inscriptions, subject to review, indicating equipment and fasten with epoxy cement and engrave black Lamicaid sheet with white lettering.
- B. Provide nameplates for the following:
 - 1. Disconnect switches.
 - 2. Individual circuit breakers.
 - 3. Panels.
 - 4. Cabinets

PART 3 - EXECUTION

3.1 EXCAVATION AND BACKFILL

- A. Excavate, backfill and restore surfaces inside building.
- B. Excavate, backfill and restore surfaces inside and outside building.
- C. Excavate, backfill and restore surfaces outside building.
- D. If rock is encountered, excavate to 6 inches below bottom of piping and refill with well tamped sand and gravel.
- E. Bank excavated materials adjacent to trench and properly support with sheet-pile and brace.
- F. Install and maintain guards and keep excavation free of water with attended pumping equipment.
- G. No extra compensation will be provided for quicksand, hardpan, or other material encountered in excavating, except rock on unit price basis.
- H. Remove bog or other swampy conditions encountered in excavating to 1 ft below bottom of piping and backfill with well tamped sand, finely crushed stone, or gravel.
- I. Immediately after piping is installed, inspected, tested, and accepted, remove sheet piping with special care to solidly fill voids without damage to piping. Backfill in a manner to prevent future settlement with only good clean loam, clay, sand, or gravel that is free from frozen materials, lumps of clay, rocks, boulders, cinders, slag ashes, vegetable or organic materials, or building or other debris, or refuse.

1. Hand fill in 4 inch layers up to 2 ft above pipe and remainder; fill in with 1 ft layers.
 2. Tamp and puddle each layer before placing next layer.
 3. Allow no stones larger than 2 in. diameter in fill up to 2 ft above piping and allow no stones larger than 4 in. diameter in fill over 2 ft above piping.
- J. Restore surfaces, sidewalks, pavements, curbing, lawns, and shrubs that are disturbed or damaged.
- K. Dispose of acceptable surplus excavation on site and remove surplus and unsuitable excavated materials from site as directed.

3.2 PAINTING

- A. Provide labor, materials and equipment necessary for field prime painting and apply in accordance with manufacturers' instructions.
- B. Apply zinc based primer with finish to match surroundings, to marred surfaces of steel equipment and raceways.
- C. Apply galvanized iron primer on panel and pull boxes, after fabrication.
- D. Apply hot dip galvanizing or dip in zinc based primer: outlet boxes, junction boxes, conduit hangers, rods, inserts, and supports.
- E. Field apply zinc based primer coat on non-galvanized steel and iron work.

3.3 FOUNDATIONS

- A. Foundations will be provided under General Construction Work.
- B. Provide foundations utilizing concrete as specified herein:
1. Provide one portland cement, two parts fine aggregate, and four parts coarse aggregate.
 2. Provide concrete of the same consistency as specified under General Construction Work.
 3. Provide concrete, poured in place on roughened concrete floor, cleaned and flushed with coat of cement grout. Do not pour grout until concrete has set. Foundation shall be puddled and finished smooth with reinforcing as noted.
 4. Provide floor free foundation forms and special foundations as noted.
- C. Hold vibration isolation and anchor bolts in position during pour. Set anchor bolts in oversized sleeves with washers and nuts at bottom. Finish flush with nuts on top.
- D. Foundations shall extend 6 in. beyond equipment, except as noted, with a minimum height of 4 in.
- E. Forms:
1. Forms will be provided under General Construction Work.
 2. Provide moisture-resistant commercial standard fir with non-staining mineral oil interior surface coating with rounded or chamfered edges.
 3. Provide galvanized NO. 18 USSG steel forms with welded seams & joints with bent top and bottom edges to form 2 in. integral internal angles (bend back exposed edges) and metal cross-strip bracing, welded to top and bottom angle edges, and intermediate bracing welded or riveted to sides as required.
 - a. Bottoms for floor free foundations.

- F. Provide foundations for the following:
 - 1. Switchboards.
 - 2. Engine Generators
 - 3. Outdoor lighting fixture standards.
 - 4. As noted.

3.4 FIELD QUALITY CONTROL

- A. Perform tests as noted, and in the presence of the Architect and/or Engineer in accordance with authorities having jurisdiction.
- B. Repair or replace defective work, as directed and pay for restoring or replacing damaged work of others, due to tests, as directed.

3.5 CLEANING

- A. Brush and clean work prior to concealing, painting and acceptance. Perform in stages if directed.
- B. Clean and repair painted exposed work, soiled or damaged, to match adjoining work before final acceptance.
- C. Remove debris from inside and outside of materials and equipment.

END OF SECTION

SECTION 26 00 01

SUPPLEMENTARY CONDITIONS FOR MECHANICAL, ELECTRICAL, PLUMBING AND FIRE PROTECTION WORK

PART 1 - GENERAL

1.1 RELATED DOCUMENTS

- A. The "GENERAL CONDITIONS OF THE CONTRACT FOR CONSTRUCTION", AIA Document A201-1997, is part of this Contract.
- B. Section 01 81 13 "Sustainable Design Requirements – LEED v4 for Building Design & Construction – New Construction" for sustainable design requirements and detailed sustainable design submittal requirements.
- C. Section 01 74 19 "Construction and Demolition Waste Management and Disposal" for disposal of construction, demolition and packaging waste disposal requirements.

PART 2 - SUPPLEMENTARY CONDITIONS

These SUPPLEMENTARY CONDITIONS amend or supplement the GENERAL CONDITIONS and other provisions of the Contract Documents as indicated below. All provisions which are not so amended or supplemented remain in full force and effect. AIA document A201-1997 Edition is referenced.

2.1 GENERAL PROVISIONS SUMMARY

- A. Section Includes:
 - 1. Rubber expansion joints.
 - 2. Flexible-hose expansion joints.
 - 3. Pipe bends and loops.
 - 4. Alignment guides and anchors.
- B. Sustainable Building Requirements:
 - 1. The Owner requires the Contractor to implement practices and procedures to meet the project's environmental performance goals, which include achieving LEED version 4 Certified level Certification. Specific project goals that may impact this area of work include: use of recycled-content materials; use of locally-manufactured materials; use of low-emitting materials; construction waste recycling; and the implementation of a construction indoor air quality management plan. The Contractor shall ensure that the requirements related to these goals, as defined in the Articles below, are implemented to the fullest extent. Substitutions, or other changes to the work proposed by the Contractor or their Subcontractors, shall not be allowed if such changes compromise the aforementioned environmental goals and LEED certification.

2.2 CORRELATION AND INTENT OF CONTRACT DOCUMENTS

- A. No reassignment of division of responsibility for work as specified for the respective trades shall be made without prior written acceptance by Engineer.

2.3 SUPERINTENDENT

- A. Contractor shall arrange for Subcontractors for Heating, Ventilation and Air Conditioning work, Electrical Work, Fire Protection Work, Plumbing Work, or any other division of work, to each supply services of a competent project manager who shall act as assistants to the Superintendent and who shall be in attendance at the Project site during the progress of the Work. Such project managers shall be satisfactory to the Engineer, and shall not be changed except with the consent of the Architect

2.4 DOCUMENTS AND SAMPLES AT THE SITE

- A. Dimension underground utilities from permanent identifiable benchmarks on Record Drawings.

2.5 RECORD DRAWINGS

- A. Before commencing work, procure complete reproducible set of Contract Drawings
- B. Conspicuously indicate major deviations in Mechanical Equipment Rooms by specific reference to shop drawings of these rooms and submit reproducibles of such shop drawings
- C. Submit up-to-date "in progress" prints, to Architect when requesting 25 percent, 50 percent, 75 percent and 95 percent payment of work installed
- D. Upon completion of work, submit signed certified reproducibles of Record and reference shop drawings, along with marked-up prints of in-progress drawing to Architect for acceptance. Also provide an electronic version of the as-built drawings

2.6 SHOP DRAWINGS, PRODUCT DATA AND SAMPLES

- A. Any Shop Drawing, Product Data or Sample submitted without Contractor's approval will not be processed for approval by the Architect, but will be returned to the Contractor for his compliance with the above procedures, in which event it will be deemed that the Contractor has not complied with the provisions herein specified and the Contractor shall bear risk of all delays as if no Shop Drawing, Product Data or Sample had been submitted.
- B. Check the Shop Drawings, Product Data, and Samples for complete dimensional accuracy; that he has checked to insure that work contiguous with and having bearing on the work shown on the Shop Drawings is accurately and clearly shown, that he has checked the Shop Drawings against the Composite Drawings prepared by the Contractor, and that the work has been coordinated and that the equipment will fit into the assigned spaces.
- C. Prior to shop drawings and sample submissions, and within 30 days after award of contract, submit lists of proposed manufacturers names, shop drawings and samples with proposed schedule of submission dates referenced by Specification Section, Article Numbers and Contract Drawing Number. Contractor shall be responsible for any delays resulting from failure to submit such lists
- D. Submit shop drawings and samples for materials, equipment and systems as noted in each respective specification section for each trade
- E. Any construction and/or design changes as a result of any approved substitution shall be made at no additional cost to the Owner
- F. Composite Drawings:

1. In the interest of coordination and to expedite the work in critical areas, the Contractor shall prepare and submit, to the Architect for review, Composite Drawings incorporating the work of the various trades and/or subcontractor involved. After review, the Contractor shall distribute prints of reviewed Composite Drawings to affected trades and/or subcontractors. The Contractor shall require that the involved trades and/or subcontractors cooperate in preparation of the Composite Drawings to assure proper coordination between trades and/or subcontractors. The participating parties shall indicate their approval on these drawings, in addition to the Contractor
- G. Provide composite shop drawings 1:33 (3/8 inch per foot) scale or as approved of areas where contractors proposed installation is at variance with the Contract Drawings or Specifications. Ductwork, piping layout and distribution drawings are not required if they conform to the Contract Drawings, except as required below for specific areas
 1. Equipment Rooms.
 2. Plenums.
 3. Shafts.
 4. Roof Level
- H. Indicate dimensioned layouts, elevations and sections of the following, on composite shop drawings
 1. Piping and valves.
 2. Raceways.
 3. Pull boxes.
 4. Lighting.
 5. Equipment.
 6. Connections.
 7. Access for servicing.
 8. Building construction (floor, ceiling, beams and columns).
- I. Plan work to allow sufficient time for coordination and for compliance with construction schedule
- J. Catalog, model and serial numbers will be assumed to represent equipment complying with Contract Drawings and Specifications, unless otherwise noted
- K. Submit additional shop drawings (other than noted) when directed, during progress of project
- L. Shop drawing resubmissions are required within 30 days of receipt of review comments from Architect
- M. Replace all material and equipment which was installed prior to shop drawing review when directed by Architect
- N. Before submitting shop drawings and samples, check material and equipment against drawings for clearance, connections, accessibility, servicing and maintenance
- O. Submit shop drawings with:
 1. Marked notation of any deviations from the Contract Documents and reasons for same. Indicate such deviations in a conspicuous manner including component, material and system variations, additions and deletions revised equipment locations, hung ceiling heights and headroom conditions.

2. Manufacturer's specifications including: materials, type, performance characteristics, voltage, phase and capacity. Specifications for project shall be tailored to reflect the requirements of the contract documents.
 3. Certified dimensional drawings, indicating sizes, component parts and installation details.
 4. Wiring diagrams when applicable
 5. Identify with:
 - a. Project name and number
 - b. Names of Architect and Engineer
 - c. Identification of applicable items on each submission
 - d. Applicable Contract Specification Section and Article Numbers
 - e. Applicable Contract Drawing Numbers
 6. Minimum copies of shop drawing submissions:
 - a. 8-1/2 inch by 14 inch and smaller: 2 copies
 - b. Larger than 8-1/2 inch by 14 inch: 1 reproducible plus 1 print
 7. All fire walls and smoke partitions must be highlighted on the sheet metal drawings for appropriate coordination
- 2.7 Cleaning Up
1. Remove broken or scratched glass and replace with new glass, remove paint drippings, spots, stains, and dirt from finished surfaces and clean fixtures, hardware, floors and equipment. Contractor shall keep interior of the building free of stored or unattended combustible material
- 2.8 INDEMNIFICATION
1. Relieve Owner of all claims in connection with use of facilities, conveniences or services supplied by other parties
- 2.9 ADMINISTRATION OF THE CONTRACT
- A. Whenever the word "Architect" occurs, the word "Engineer" shall be substituted, and shall mean the firm of Atkinson Koven Feinberg, LLP or its authorized representative.
- 2.10 PROTECTION OF PERSONS AND PROPERTY
- A. SAFETY OF PERSONS AND PROPERTY
 1. Close open ends of work with temporary covers or plugs during construction to prevent entry of obstructing materials
 2. Storage areas will be designated by Architect or Building Owner
 - B. USE OF PERMANENT INSTALLATION
 1. No equipment intended for permanent installation shall be operated for temporary purposes without written permission of, and complete agreement with stipulation as set forth by, the Architect
- 2.11 INSURANCE AND BONDS
- A. The Contractor shall procure and maintain, at his own expense, until final acceptance of all the work covered by this Contractor, the following kinds of insurance:
 1. Workmen's Compensation Insurance: A policy complying with the requirements of the laws of the State of Maine
 2. The contractor shall obtain all specific insurance requirements FROM the owner
 3. Contractor's Comprehensive General Liability and Property Damage Insurance: A standard comprehensive general liability insurance policy, with

contractual and completed operations coverage, issued to and covering the liability of the Contractor for all work and operations under this Contract. The coverage under such a policy shall be in accordance with the Owner's requirements

4. Automobile Liability and Property Damage Insurance. A policy covering the use in connection with the work covered by Contract Documents of all owned, non-owned and hired vehicles bearing, or, under the circumstances under which they are being used, required by the Motor Vehicles Laws of the State of New York to bear license plates. The coverage under such policy shall be in accordance with Owner's requirements
5. Before commencing the performance of any work covered by the Contract, the Contractor shall furnish to Owner a certificate of the insurance required under the foregoing provisions
6. If at any time any of the above required insurance policies should be canceled, terminate or modified so that insurance is not in effect as above required, then, if the Owner shall so direct, the Contractor shall suspend performance of the work covered in the Contract. If the said work is so suspended, no extension of time shall be due on account thereof. If said work is not suspended the Owner may, at its option, obtain insurance affording coverage equal to that above required, the cost of such insurance to be payable by the Contractor to the Owner

2.12 DEVIATIONS

- A. When deviations to Contract Documents are requested by the Contractor and accepted by the Architect, Contractor shall be responsible for all affected work and costs, including that of other contracts.
- B. Interference With Owner's Operations
 1. Contractors shall take whatever action is necessary to avoid interference with owner's use of the building or damage to existing facilities equipment
 2. Except as otherwise specified herein, contractors may work during normal working hours. In the event that noisy work interferes with owner's operations, owner may direct contractor to stop that work. If the workers involved cannot be used on other work, Contractor shall be paid for the lost time in accordance with a schedule of hourly rates to be included in the contract. Owner's representative will determine the duration of the stoppage and whether compensation therefor is warranted
 3. Contractor shall include with his proposal a schedule of hourly rates and overtime premiums
 4. Maintain building services in operation

2.13 PROJECT CLOSEOUT PROCEDURES

- A. General
 1. The requirements of this section are in addition to and supplement the requirements outlined in Division 1.
 2. It shall be each contractor's responsibility to personally hand-deliver all of the required project closeout checklist items and to obtain Owner's authorized representative(s) signed receipt on all items requiring Owner sign-off

2.14 Project Closeout Checklist

1. Review requirements of each section of the specifications and submit for approval to Architect the sign-off forms which shall become the project closeout checklist. These, at a minimum, shall include the following

information shown in attached Project Closeout Checklist Example. The Architect and/or Owner may incorporate additional specific items to the following checklist which shall become part of the project requirements

2.15 Closeout Checklist Example:

PROJECT CLOSETOUT			
PROJECT:			
DIVISION NO.:			
CONTRACTOR:			
ITEM ¹	DATES		OWNER'S SIGN-OFF
	COMPLETED	RECEIVED BY OWNER	
Permits			
City and County Inspection			
Manufacturer's warranties			
Contractor's Warranties			
State Fire Rating Data			
Copy of Final Shop Drawings			
List and Possession of Spare Parts			
Pressure Tests			
Equipment Tests Required by Specs			
O & M Manuals			
Record Documents			
Coordination Drawings			
Sanitization Reports			
Commissioning reports/Letters/Forms			
On-Site Training Complete			
Protective Device Settings			
Valve Tags and Charts			
Final ATC Installation Drawings			
Insurance Underwriters Approvals			
Final Punch List (Initialed by contractor that items are complete)			
Building Certificate of Occupancy (C.O.)			
24-Hour Phone No. for Service During Guarantee Period			

END OF SECTION

SECTION 26 05 00

COMMON WORK RESULTS FOR ELECTRICAL

PART 1 - GENERAL

1.1 RELATED DOCUMENTS

- A. The Contractor, Subcontractors, and/or suppliers providing goods or services referenced in or related to this Section shall also be bound by the Documents identified in Division 01 Section "Summary", Paragraph 1.01A, entitled "Related Documents."
- B. Section 01 81 13 "Sustainable Design Requirements – LEED v4 for Building Design & Construction – New Construction" for sustainable design requirements and detailed sustainable design submittal requirements.
- C. Section 01 74 19 "Construction and Demolition Waste Management and Disposal" for disposal of construction, demolition and packaging waste disposal requirements.

1.2 SUMMARY

- A. Section Includes:
 - 1. Electrical equipment coordination and installation.
 - 2. Sleeves for raceways and cables.
 - 3. Sleeve seals.
 - 4. Grout.
 - 5. Common electrical installation requirements.
- B. Sustainable Building Requirements:
 - 1. The Owner requires the Contractor to implement practices and procedures to meet the project's environmental performance goals, which include achieving LEED version 4 **Certified** level Certification. Specific project goals that may impact this area of work include: use of recycled-content materials; use of locally-manufactured materials; use of low-emitting materials; construction waste recycling; and the implementation of a construction indoor air quality management plan. The Contractor shall ensure that the requirements related to these goals, as defined in the Articles below, are implemented to the fullest extent. Substitutions, or other changes to the work proposed by the Contractor or their Subcontractors, shall not be allowed if such changes compromise the aforementioned environmental goals and LEED certification.

1.3 DEFINITIONS

- A. EPDM: Ethylene-propylene-diene terpolymer rubber.
- B. NBR: Acrylonitrile-butadiene rubber.

1.4 SUBMITTALS

- A. Product Data: For sleeve seals.

1.5 COORDINATION

- A. Coordinate arrangement, mounting, and support of electrical equipment:
 - 1. To allow maximum possible headroom unless specific mounting heights that reduce headroom are indicated.
 - 2. To provide for ease of disconnecting the equipment with minimum interference to other installations.
 - 3. To allow right of way for piping and conduit installed at required slope.
 - 4. So connecting raceways, cables, wireways, cable trays, and busways will be clear of obstructions and of the working and access space of other equipment.
- B. Coordinate installation of required supporting devices and set sleeves in cast-in-place concrete, masonry walls, and other structural components as they are constructed.
- C. Coordinate location of access panels and doors for electrical items that are behind finished surfaces or otherwise concealed. Access doors and panels are specified in "Access Doors and Frames."
- D. Coordinate sleeve selection and application with selection and application of fire stopping specified in "Penetration Fire stopping."

PART 2 - PRODUCTS

2.1 SLEEVES FOR RACEWAYS AND CABLES

- A. Steel Pipe Sleeves: ASTM A 53/A 53M, Type E, Grade B, Schedule 40, galvanized steel, plain ends.
- B. Cast-Iron Pipe Sleeves: Cast or fabricated "wall pipe," equivalent to ductile-iron pressure pipe, with plain ends and integral water stop, unless otherwise indicated.
- C. Sleeves for Rectangular Openings: Galvanized sheet steel.
 - 1. Minimum Metal Thickness:
 - a. For sleeve cross-section rectangle perimeter less than 50 inches (1270 mm) and no side more than 16 inches (400 mm), thickness shall be 0.052 inch (1.3 mm).
 - b. For sleeve cross-section rectangle perimeter equal to, or more than, 50 inches (1270 mm) and 1 or more sides equal to, or more than, 16 inches (400 mm), thickness shall be 0.138 inch (3.5 mm).

2.2 SLEEVE SEALS

- A. Description: Modular sealing device, designed for field assembly, to fill annular space between sleeve and raceway or cable.
 - 1. Basis-of-Design Product: Subject to compliance with requirements, comparable product by one of the following:
 - a. Advance Products & Systems, Inc.
 - b. Calpico, Inc.
 - c. Metraflex Co.

- d. Pipeline Seal and Insulator, Inc.
- e. Link-Seal
- 2. Sealing Elements: EPDM interlocking links shaped to fit surface of cable or conduit. Include type and number required for material and size of raceway or cable.
- 3. Pressure Plates: Stainless steel. Include two for each sealing element.
- 4. Connecting Bolts and Nuts: Carbon with corrosion-resistant coating of length required to secure pressure plates to sealing elements. Include one for each sealing element.

2.3 GROUT

- A. Nonmetallic, Shrinkage-Resistant Grout: ASTM C 1107, factory-packaged, nonmetallic aggregate grout, noncorrosive, non-staining, mixed with water to consistency suitable for application and a 30-minute working time.

PART 3 - EXECUTION

3.1 COMMON REQUIREMENTS FOR ELECTRICAL INSTALLATION

- A. Comply with NECA 1.
- B. Measure indicated mounting heights to bottom of unit for suspended items and to center of unit for wall-mounting items.
- C. Headroom Maintenance: If mounting heights or other location criteria are not indicated, arrange and install components and equipment to provide maximum possible headroom consistent with these requirements.
- D. Equipment: Install to facilitate service, maintenance, and repair or replacement of components of both electrical equipment and other nearby installations. Connect in such a way as to facilitate future disconnecting with minimum interference with other items in the vicinity.
- E. Right of Way: Give to piping systems installed at a required slope.

3.2 SLEEVE INSTALLATION FOR ELECTRICAL PENETRATIONS

- A. Electrical penetrations occur when raceways, cables, wireways, cable trays, or busways penetrate concrete slabs, concrete or masonry walls, or fire-rated floor and wall assemblies.
- B. Concrete Slabs and Walls: Install sleeves for penetrations unless core-drilled holes or formed openings are used. Install sleeves during erection of slabs and walls.
- C. Use pipe sleeves unless penetration arrangement requires rectangular sleeved opening.
- D. Fire-Rated Assemblies: Install sleeves for penetrations of fire-rated floor and wall assemblies unless openings compatible with fire stop system used are fabricated during construction of floor or wall.
- E. Cut sleeves to length for mounting flush with both surfaces of walls.
- F. Extend sleeves installed in floors 2 inches (50 mm) above finished floor level.

- G. Size pipe sleeves to provide 1/4-inch (6.4-mm) annular clear space between sleeve and raceway or cable, unless indicated otherwise.
- H. Seal space outside of sleeves with grout for penetrations of concrete and masonry
 - 1. Promptly pack grout solidly between sleeve and wall so no voids remain. Tool exposed surfaces smooth; protect grout while curing.
- I. Interior Penetrations of Non-Fire-Rated Walls and Floors: Seal annular space between sleeve and raceway or cable, using joint sealant appropriate for size, depth, and location of joint. Comply with requirements in "Joint Sealants."
- J. Fire-Rated-Assembly Penetrations: Maintain indicated fire rating of walls, partitions, ceilings, and floors at raceway and cable penetrations. Install sleeves and seal raceway and cable penetration sleeves with fire stop materials. Comply with requirements in "Penetration Fire stopping."
- K. Roof-Penetration Sleeves: Seal penetration of individual raceways and cables with flexible boot-type flashing units applied in coordination with roofing work.
- L. Aboveground, Exterior-Wall Penetrations: Seal penetrations using cast iron pipe sleeves and mechanical sleeve seals. Select sleeve size to allow for 1-inch (25-mm) annular clear space between pipe and sleeve for installing mechanical sleeve seals.
- M. Underground, Exterior-Wall Penetrations: Install cast-iron pipe sleeves. Size sleeves to allow for 1-inch (25-mm) annular clear space between raceway or cable and sleeve for installing mechanical sleeve seals.

3.3 SLEEVE-SEAL INSTALLATION

- A. Install to seal exterior wall penetrations.
- B. Use type and number of sealing elements recommended by manufacturer for raceway or cable material and size. Position raceway or cable in center of sleeve. Assemble mechanical sleeve seals and install in annular space between raceway or cable and sleeve. Tighten bolts against pressure plates that cause sealing elements to expand and make watertight seal.

3.4 FIRE STOPPING

- A. Apply fire stopping to penetrations of fire-rated floor and wall assemblies for electrical installations to restore original fire-resistance rating of assembly. Fire stopping materials and installation requirements are specified in "Penetration Fire stopping."

END OF SECTION

SECTION 26 05 19

LOW-VOLTAGE ELECTRICAL POWER CONDUCTORS AND CABLES

PART 1 - GENERAL

1.1 RELATED DOCUMENTS

- A. Drawings and general provisions of the Contract, including General and Supplementary Conditions and Division 01 Specification Sections, apply to this Section.
- B. Section 01 81 13 "Sustainable Design Requirements – LEED v4 for Building Design & Construction – New Construction" for sustainable design requirements and detailed sustainable design submittal requirements.
- C. Section 01 74 19 "Construction and Demolition Waste Management and Disposal" for disposal of construction, demolition and packaging waste disposal requirements.

1.2 SUMMARY

- A. This Section includes the following:
 - 1. Building wires and cables rated 600 V and less.
 - 2. Connectors, splices, and terminations rated 600 V and less.
 - 3. Sleeves and sleeve seals for cables.
- B. Sustainable Building Requirements:
 - 1. The Owner requires the Contractor to implement practices and procedures to meet the project's environmental performance goals, which include achieving LEED version 4 **Certified** level Certification. Specific project goals that may impact this area of work include: use of recycled-content materials; use of locally-manufactured materials; use of low-emitting materials; construction waste recycling; and the implementation of a construction indoor air quality management plan. The Contractor shall ensure that the requirements related to these goals, as defined in the Articles below, are implemented to the fullest extent. Substitutions, or other changes to the work proposed by the Contractor or their Subcontractors, shall not be allowed if such changes compromise the aforementioned environmental goals and LEED certification.

1.3 DEFINITIONS

- A. EPDM: Ethylene-propylene-diene terpolymer rubber.
- B. NBR: Acrylonitrile-butadiene rubber.

1.4 SUBMITTALS

- A. Product Data: For each type of product indicated.

- B. Qualification Data: For testing agency.
- C. Field quality-control test reports.

1.5 QUALITY ASSURANCE

- A. Testing Agency Qualifications: An independent agency, with the experience and capability to conduct the testing indicated, that is a member company of the InterNational Electrical Testing Association or is a nationally recognized testing laboratory (NRTL) as defined by OSHA in 29 CFR 1910.7, and that is acceptable to authorities having jurisdiction.
 - 1. Testing Agency's Field Supervisor: Person currently certified by the InterNational Electrical Testing Association or the National Institute for Certification in Engineering Technologies to supervise on-site testing specified in Part 3.
- B. Electrical Components, Devices, and Accessories: Listed and labeled as defined in NFPA 70, Article 100, by a testing agency acceptable to authorities having jurisdiction, and marked for intended use.
- C. Comply with NFPA 70.

1.6 COORDINATION

- A. Set sleeves in cast-in-place concrete, masonry walls, and other structural components as they are constructed.

PART 2 - PRODUCTS

2.1 CONDUCTORS AND CABLES

- A. Manufacturers: Subject to compliance with requirements, provide products by one of the following:
 - 1. American Insulated Wire Corp.; a Leviton Company.
 - 2. General Cable Corporation.
 - 3. Senator Wire & Cable Company.
 - 4. Southwire Company.
 - 5. AFC Cable Systems, Inc.
- B. Copper and Aluminum Conductors: Comply with NEMA WC 70.
- C. Conductor Insulation: Comply with NEMA WC 70 for Types THW, THHN-THWN and XHHW.
- D. Multiconductor Cable: Comply with NEMA WC 70 for armored cable, Type AC, metal-clad cable, Type MC and mineral-insulated, metal-sheathed cable, Type MI.
 - 1. Type MC cable shall be high strength, lightweight galvanized steel armor equal to AFC Cable Systems, Inc. "MC TUFF."
 - 2. Conductors shall be copper with thermoplastic insulation, type THHN/THWN. Insulation shall be color coded for 120/208 volt systems and 480/277 volt systems as specified in Section 26 - "Identification for Electrical Systems."
 - 3. Hospital Grade type AC cable shall be high strength galvanized steel armor with green stripe equal to AFC Cable Systems, Inc. "HCF - 90."

4. Type AC conductors shall be copper with thermoplastic insulation, type THHN. Each conductor shall be paper wrapped. There shall be a bare # 16 AWG integral bond conductor and separated insulated # 12 AWG ground conductor. Insulation shall be color coded as specified in Section 26 - "Identification for Electrical Systems."

2.2 CONNECTORS AND SPLICES

- A. Manufacturers: Subject to compliance with requirements, provide products by one of the following:
 1. AFC Cable Systems, Inc.
 2. Hubbell Power Systems, Inc.
 3. O-Z/Gedney; EGS Electrical Group LLC.
 4. 3M; Electrical Products Division.
 5. Tyco Electronics Corp.
- B. Description: Factory-fabricated connectors and splices of size, ampacity rating, material, type, and class for application and service indicated.

2.3 SLEEVES FOR CABLES

- A. Steel Pipe Sleeves: ASTM A 53/A 53M, Type E, Grade B, Schedule 40, galvanized steel, plain ends.
- B. Sleeves for Rectangular Openings: Galvanized sheet steel with minimum 0.052- or 0.138-inch (1.3- or 3.5-mm) thickness as indicated and of length to suit application.
- C. Coordinate sleeve selection and application with selection and application of firestopping specified in "Penetration Firestopping."

2.4 SLEEVE SEALS

- A. Basis-of-Design Product: Subject to compliance with requirements, provide product by one of the following:
 1. Advance Products & Systems, Inc.
 2. Calpico, Inc.
 3. Metraflex Co.
 4. Pipeline Seal and Insulator, Inc.
 5. Link Seal
- B. Description: Modular sealing device, designed for field assembly, to fill annular space between sleeve and cable.
 1. Sealing Elements: NBR interlocking links shaped to fit surface of cable or conduit. Include type and number required for material and size of raceway or cable.
 2. Pressure Plates: Stainless steel. Include two for each sealing element.
 3. Connecting Bolts and Nuts: Stainless steel of length required to secure pressure plates to sealing elements. Include one for each sealing element.

PART 3 - EXECUTION

3.1 CONDUCTOR MATERIAL APPLICATIONS

- A. Feeders: Copper. Solid for No. 10 AWG and smaller; stranded for No. 8 AWG and larger.
- B. Branch Circuits: Copper. Solid for No. 10 AWG and smaller; stranded for No. 8 AWG and larger.

3.2 CONDUCTOR INSULATION AND MULTICONDUCTOR CABLE APPLICATIONS AND WIRING METHODS

- A. Service Entrance: Type XHHW-2, single conductors in raceway.
- B. Exposed Feeders: Type XHHW-2, single conductors in raceway.
- C. Feeders Concealed in Ceilings, Walls, Partitions, and Crawlspace: Type THHN-THWN, single conductors in raceway. Type MI Cable where indicated on schedules and drawings.
- D. Feeders Concealed in Concrete, below Slabs-on-Grade, and Underground: Type XHHW-2, single conductors in raceway.
- E. Exposed Branch Circuits, Including in Crawlspace: Type THHN-THWN, single conductors in raceway.
- F. Branch Circuits Concealed in Ceilings, Walls, and Partitions Metal-clad cable, Type MC. Type AC (hospital grade) or type MC may be used for branch circuit wiring. All homerun wiring shall be in raceway. All emergency circuits shall be in non flexible conduit.
- G. Branch circuits in patient care areas and surgical areas: Armored cable type AC-Hospital grade "HCF-90".
- H. Branch Circuits from essential branch (Healthcare Article 517), Type THHN-THWN, single conductors in non-flexible metallic raceway.
- I. Branch Circuits Concealed in Concrete, below Slabs-on-Grade, and Underground: Type THHN-THWN, single conductors in raceway.
- J. Branch Circuits in Operating Rooms: Low Leakage type XLP, single conductors in raceway.
- K. Class 1 Control Circuits: Type THHN-THWN, in raceway.
- L. Class 2 Control Circuits: Type THHN-THWN, in raceway.
- M. Type AC and/or type MC cable shall be installed in the best and shortest route for each cable run. Long runs of spider web type routing is unacceptable. Support cables with approved supports within 12" of every termination and type AC cable every 4 1/2" and type MC cable every 6". When terminating or splicing, cut cable so that 6 inches of free conductor is left for connection or splices. Use an approved connector and insure a proper bond by firmly tightening the connector to both the box and the cable. When terminating cable, provide and insert an approved anti-short bushing.

3.3 INSTALLATION OF CONDUCTORS AND CABLES

- A. Conceal cables in finished walls and ceilings for floor mounted devices run conduit and cable in ceiling below.
- B. Use manufacturer-approved pulling compound or lubricant where necessary; compound used must not deteriorate conductor or insulation. Do not exceed manufacturer's recommended maximum pulling tensions and sidewall pressure values.
- C. Use pulling means, including fish tape, cable, rope, and basket-weave wire/cable grips that will not damage cables or raceway.
- D. Install exposed cables parallel and perpendicular to surfaces of exposed structural members, and follow surface contours where possible.
- E. Support cables according to Division 26 Section "Hangers and Supports for Electrical Systems."
- F. Identify and color-code conductors and cables according to Division 26 Section "Identification for Electrical Systems."

3.4 CONNECTIONS

- A. Tighten electrical connectors and terminals according to manufacturer's published torque-tightening values. If manufacturer's torque values are not indicated, use those specified in UL 486A and UL 486B.
- B. Make splices and taps that are compatible with conductor material and that possess equivalent or better mechanical strength and insulation ratings than unspliced conductors.
- C. Wiring at Outlets: Install conductor at each outlet, with at least 6 inches (150 mm) of slack.

3.5 SLEEVE INSTALLATION FOR ELECTRICAL PENETRATIONS

- A. Coordinate sleeve selection and application with selection and application of firestopping specified in "Penetration Firestopping."
- B. Concrete Slabs and Walls: Install sleeves for penetrations unless core-drilled holes or formed openings are used. Install sleeves during erection of slabs and walls.
- C. Use pipe sleeves unless penetration arrangement requires rectangular sleeved opening.
- D. Rectangular Sleeve Minimum Metal Thickness:
 - 1. For sleeve rectangle perimeter less than 50 inches (1270 mm) and no side greater than 16 inches (400 mm), thickness shall be 0.052 inch (1.3 mm).
 - 2. For sleeve rectangle perimeter equal to, or greater than, 50 inches (1270 mm) and 1 or more sides equal to, or greater than, 16 inches (400 mm), thickness shall be 0.138 inch (3.5 mm).
- E. Fire-Rated Assemblies: Install sleeves for penetrations of fire-rated floor and wall assemblies unless openings compatible with firestop system used are fabricated during construction of floor or wall.
- F. Cut sleeves to length for mounting flush with both wall surfaces.

- G. Extend sleeves installed in floors 2 inches (50 mm) above finished floor level.
- H. Size pipe sleeves to provide 1/4-inch (6.4-mm) annular clear space between sleeve and cable unless sleeve seal is to be installed or unless seismic criteria require different clearance.
- I. Seal space outside of sleeves with grout for penetrations of concrete and masonry and with approved joint compound for gypsum board assemblies.
- J. Interior Penetrations of Non-Fire-Rated Walls and Floors: Seal annular space between sleeve and cable, using joint sealant appropriate for size, depth, and location of joint according to "Joint Sealants."
- K. Fire-Rated-Assembly Penetrations: Maintain indicated fire rating of walls, partitions, ceilings, and floors at cable penetrations. Install sleeves and seal with firestop materials according to Section "Penetration Firestopping."
- L. Roof-Penetration Sleeves: Seal penetration of individual cables with flexible boot-type flashing units applied in coordination with roofing work.
- M. Aboveground Exterior-Wall Penetrations: Seal penetrations using sleeves and mechanical sleeve seals. Size sleeves to allow for 1-inch (25-mm) annular clear space between pipe and sleeve for installing mechanical sleeve seals.
- N. Underground Exterior-Wall Penetrations: Install cast-iron "wall pipes" for sleeves. Size sleeves to allow for 1-inch (25-mm) annular clear space between cable and sleeve for installing mechanical sleeve seals.

3.6 SLEEVE-SEAL INSTALLATION

- A. Install to seal underground exterior-wall penetrations.
- B. Use type and number of sealing elements recommended by manufacturer for cable material and size. Position cable in center of sleeve. Assemble mechanical sleeve seals and install in annular space between cable and sleeve. Tighten bolts against pressure plates that cause sealing elements to expand and make watertight seal.

3.7 FIRESTOPPING

- A. Apply firestopping to electrical penetrations of fire-rated floor and wall assemblies to restore original fire-resistance rating of assembly according to Section "Penetration Firestopping."

3.8 FIELD QUALITY CONTROL

- A. Testing Agency: Engage a qualified testing agency to perform tests and inspections and prepare test reports.
- B. Tests and Inspections:
 - 1. After installing conductors and cables and before electrical circuitry has been energized, test service entrance and all feeder conductors for compliance with requirements.
 - 2. Perform each visual and mechanical inspection and electrical test stated in NETA Acceptance Testing Specification. Certify compliance with test parameters.

3. Infrared Scanning: After Substantial Completion, but not more than 60 days after Final Acceptance, perform an infrared scan of each splice in cables and conductors No. 3 AWG and larger. Remove box and equipment covers so splices are accessible to portable scanner.
 - a. Follow-up Infrared Scanning: Perform an additional follow-up infrared scan of each splice 11 months after date of Substantial Completion.
 - b. Instrument: Use an infrared scanning device designed to measure temperature or to detect significant deviations from normal values. Provide calibration record for device.
 - c. Record of Infrared Scanning: Prepare a certified report that identifies splices checked and that describes scanning results. Include notation of deficiencies detected, remedial action taken, and observations after remedial action.
- C. Test Reports: Prepare a written report to record the following:
 1. Test procedures used.
 2. Test results that comply with requirements.
 3. Test results that do not comply with requirements and corrective action taken to achieve compliance with requirements.
- D. Remove and replace malfunctioning units and retest as specified above.

END OF SECTION

This page is intentionally left blank.

SECTION 26 05 26

GROUNDING AND BONDING FOR ELECTRICAL SYSTEMS

PART 1 - GENERAL

1.1 RELATED DOCUMENTS

- A. Drawings and general provisions of the Contract, including General and Supplementary Conditions and Division 01 Specification Sections, apply to this Section.
- B. Section 01 81 13 "Sustainable Design Requirements – LEED v4 for Building Design & Construction – New Construction" for sustainable design requirements and detailed sustainable design submittal requirements.
- C. Section 01 74 19 "Construction and Demolition Waste Management and Disposal" for disposal of construction, demolition and packaging waste disposal requirements.

1.2 SUMMARY

- A. This Section includes methods and materials for grounding systems and equipment.
- B. Sustainable Building Requirements:
 - 1. The Owner requires the Contractor to implement practices and procedures to meet the project's environmental performance goals, which include achieving LEED version 4 **Certified** level Certification. Specific project goals that may impact this area of work include: use of recycled-content materials; use of locally-manufactured materials; use of low-emitting materials; construction waste recycling; and the implementation of a construction indoor air quality management plan. The Contractor shall ensure that the requirements related to these goals, as defined in the Articles below, are implemented to the fullest extent. Substitutions, or other changes to the work proposed by the Contractor or their Subcontractors, shall not be allowed if such changes compromise the aforementioned environmental goals and LEED certification.

1.3 SUBMITTALS

- A. Product Data: For each type of product indicated.
- B. Other Informational Submittals: Plans showing dimensioned as-built locations of grounding features specified in Part 3 "Field Quality Control" Article, including the following:
 - 1. Grounding arrangements and connections for separately derived systems.
 - 2. Grounding for sensitive electronic equipment.
- C. Qualification Data: For testing agency and testing agency's field supervisor.
- D. Field quality-control test reports.

- E. Operation and Maintenance Data: For grounding to include the following in emergency, operation, and maintenance manuals:
 - 1. Instructions for periodic testing and inspection of grounding features at grounding connections for separately derived systems based on NFPA 70B.
 - a. Tests shall be to determine if ground resistance or impedance values remain within specified maximums, and instructions shall recommend corrective action if they do not.
 - b. Include recommended testing intervals.

1.4 QUALITY ASSURANCE

- A. Testing Agency Qualifications: An independent agency, with the experience and capability to conduct the testing indicated, that is a member company of the InterNational Electrical Testing Association or is a nationally recognized testing laboratory (NRTL) as defined by OSHA in 29 CFR 1910.7, and that is acceptable to authorities having jurisdiction.
 - 1. Testing Agency's Field Supervisor: Person currently certified by the InterNational Electrical Testing Association to supervise on-site testing specified in Part 3.
- B. Electrical Components, Devices, and Accessories: Listed and labeled as defined in NFPA 70, Article 100, by a testing agency acceptable to authorities having jurisdiction, and marked for intended use.
- C. Comply with UL 467 for grounding and bonding materials and equipment.

PART 2 - PRODUCTS

2.1 CONDUCTORS

- A. Insulated Conductors: Copper wire or cable insulated for 600 V unless otherwise required by applicable Code or authorities having jurisdiction.
- B. Bare Copper Conductors:
 - 1. Solid Conductors: ASTM B 3.
 - 2. Stranded Conductors: ASTM B 8.
 - 3. Bonding Jumper: Copper tape, braided conductors, terminated with copper ferrules; 1-5/8 inches (41 mm) wide and 1/16 inch (1.6 mm) thick.
- C. Bare Grounding Conductor and Conductor Protector for Wood Poles:
 - 1. No. 4 AWG minimum, soft-drawn copper.
 - 2. Conductor Protector: Half-round PVC
- D. Grounding Bus: Rectangular bars of annealed copper, 4 inches by 1/4 inches x 24 or as indicated on plans.

2.2 CONNECTORS

- A. Listed and labeled by a nationally recognized testing laboratory acceptable to authorities having jurisdiction for applications in which used, and for specific types, sizes, and combinations of conductors and other items connected.
- B. Bolted Connectors for Conductors and Pipes: Copper or copper alloy, bolted pressure-type, with at least two bolts.

1. Pipe Connectors: Clamp type, sized for pipe.
- C. Welded Connectors: Exothermic-welding kits of types recommended by kit manufacturer for materials being joined and installation conditions. Use for bonding to steel and as indicated.

PART 3 - EXECUTION

3.1 APPLICATIONS

- A. Conductors: Install solid conductor for No. 10 AWG and smaller, and stranded conductors for No. 8 AWG and larger, unless otherwise indicated.
- B. Isolated Grounding Conductors: Green-colored insulation with continuous yellow stripe. On feeders with isolated ground, identify grounding conductor where visible to normal inspection, with alternating bands of green and yellow tape, with at least three bands of green and two bands of yellow.
- C. Grounding Bus: Install in electrical rooms, and elsewhere as indicated. Length 24" or as indicated in drawings.
1. Install bus on insulated spacers 1 inch (25 mm), minimum, from wall 6 inches (150 mm) above finished floor, unless otherwise indicated.
 2. Where indicated on both sides of doorways, route bus up to top of door frame, across top of doorway, down to specified height above floor, and connect to horizontal bus.

3.2 EQUIPMENT GROUNDING

- A. Install insulated equipment grounding conductors with the following items, in addition to those required by NFPA 70:
1. Feeders and branch circuits.
 2. Lighting circuits.
 3. Receptacle circuits.
 4. Single-phase motor and appliance branch circuits.
 5. Three-phase motor and appliance branch circuits.
 6. Flexible raceway runs.
 7. Armored and metal-clad cable runs.
 8. Computer and Rack-Mounted Electronic Equipment Circuits: Install insulated equipment grounding conductor in branch-circuit runs from equipment-area power panels and power-distribution units.
 9. X-Ray Equipment Circuits: Install insulated equipment grounding conductor in circuits supplying x-ray equipment.

3.3 INSTALLATION

- A. Grounding Conductors: Route along shortest and straightest paths possible, unless otherwise indicated or required by Code. Avoid obstructing access or placing conductors where they may be subjected to strain, impact, or damage.
- B. Bonding Straps and Jumpers: Install in locations accessible for inspection and maintenance, except where routed through short lengths of conduit.
1. Bonding to Structure: Bond straps directly to basic structure, taking care not to penetrate any adjacent parts.

2. Bonding to Equipment Mounted on Vibration Isolation Hangers and Supports: Install so vibration is not transmitted to rigidly mounted equipment.
 3. Use exothermic-welded connectors for outdoor locations, but if a disconnect-type connection is required, use a bolted clamp.
- C. Bonding Interior Metal Ducts: Bond metal air ducts to equipment grounding conductors of associated fans, blowers, electric heaters, and air cleaners. Install bonding jumper to bond across flexible duct connections to achieve continuity.

3.4 FIELD QUALITY CONTROL

- A. Testing Agency: Engage a qualified testing and inspecting agency to perform the following field tests and inspections and prepare test reports:
- B. Perform the following tests and inspections and prepare test reports:
1. After installing grounding system but before permanent electrical circuits have been energized, test for compliance with requirements.
 2. Test completed grounding system at each location where a maximum ground-resistance level is specified, at service disconnect enclosure grounding terminal. Make tests at ground rods before any conductors are connected.
 - a. Perform tests by fall-of-potential method according to IEEE 81.
- C. Report measured ground resistances that exceed the following values:
1. Power and Lighting Equipment or System with Capacity 500 kVA and Less: 10 ohms.
 2. Power and Lighting Equipment or System with Capacity 500 to 1000 kVA: 5 ohms.
 3. Power and Lighting Equipment or System with Capacity More Than 1000 kVA: 3 ohms.
 4. Power Distribution Units or Panelboards Serving Electronic Equipment: 3 ohm(s).
- D. Excessive Ground Resistance: If resistance to ground exceeds specified values, notify Architect promptly and include recommendations to reduce ground resistance.

END OF SECTION

SECTION 26 05 29

HANGERS AND SUPPORTS FOR ELECTRICAL SYSTEMS

PART 1 - GENERAL

1.1 RELATED DOCUMENTS

- A. Drawings and general provisions of the Contract, including General and Supplementary Conditions and Division 01 Specification Sections, apply to this Section.
- B. Section 01 81 13 "Sustainable Design Requirements – LEED v4 for Building Design & Construction – New Construction" for sustainable design requirements and detailed sustainable design submittal requirements.
- C. Section 01 74 19 "Construction and Demolition Waste Management and Disposal" for disposal of construction, demolition and packaging waste disposal requirements.

1.2 SUMMARY

- A. This Section includes the following:
 - 1. Hangers and supports for electrical equipment and systems.
 - 2. Construction requirements for concrete bases.
- B. Related Sections include the following:
 - 1. Division 26 Section "Vibration And Seismic Controls For Electrical Systems" for products and installation requirements necessary for compliance with seismic criteria.
- C. Sustainable Building Requirements:
 - 1. The Owner requires the Contractor to implement practices and procedures to meet the project's environmental performance goals, which include achieving LEED version 4 Certified level Certification. Specific project goals that may impact this area of work include: use of recycled-content materials; use of locally-manufactured materials; use of low-emitting materials; construction waste recycling; and the implementation of a construction indoor air quality management plan. The Contractor shall ensure that the requirements related to these goals, as defined in the Articles below, are implemented to the fullest extent. Substitutions, or other changes to the work proposed by the Contractor or their Subcontractors, shall not be allowed if such changes compromise the aforementioned environmental goals and LEED certification.

1.3 DEFINITIONS

- A. EMT: Electrical metallic tubing.
- B. RMC: Rigid metal conduit.

1.4 PERFORMANCE REQUIREMENTS

- A. Delegated Design: Design supports for multiple raceways, including comprehensive engineering analysis by a qualified professional engineer, using performance requirements and design criteria indicated.
- B. Design supports for multiple raceways capable of supporting combined weight of supported systems and its contents.
- C. Design equipment supports capable of supporting combined operating weight of supported equipment and connected systems and components.
- D. Rated Strength: Adequate in tension, shear, and pullout force to resist maximum loads calculated or imposed for this Project,.

1.5 SUBMITTALS

- A. Product Data: For the following:
 - 1. Steel slotted support systems.
- B. Shop Drawings: Show fabrication and installation details and include calculations for the following:
 - 1. Trapeze hangers. Include Product Data for components.
 - 2. Steel slotted channel systems. Include Product Data for components.
 - 3. Equipment supports.
- C. Welding certificates.

1.6 QUALITY ASSURANCE

- A. Welding: Qualify procedures and personnel according to AWS D1.1/D1.1M, "Structural Welding Code - Steel."
- B. Comply with NFPA 70.

1.7 COORDINATION

- A. Coordinate size and location of concrete bases. Cast anchor-bolt inserts into bases. Concrete, reinforcement, and formwork requirements are specified in.
- B. Coordinate installation of roof curbs, equipment supports, and roof penetrations. These items are specified in Section "Roof Accessories."

PART 2 - PRODUCTS

2.1 SUPPORT, ANCHORAGE, AND ATTACHMENT COMPONENTS

- A. Steel Slotted Support Systems: Comply with MFMA-4, factory-fabricated components for field assembly.
 - 1. Manufacturers: Subject to compliance with requirements, provide products by one of the following:
 - a. Allied Tube & Conduit.
 - b. Cooper B-Line, Inc.; a division of Cooper Industries.
 - c. ERICO International Corporation.
 - d. Thomas & Betts Corporation.

- e. Unistrut; Tyco International, Ltd.
 - f. Wesanco, Inc.
 2. Metallic Coatings: Hot-dip galvanized after fabrication and applied according to MFMA-4.
 3. Painted Coatings: Manufacturer's standard painted coating applied according to MFMA-4.
 4. Channel Dimensions: Selected for applicable load criteria.
- B. Raceway and Cable Supports: As described in NECA 1 and NECA 101.
- C. Conduit and Cable Support Devices: Steel hangers, clamps, and associated fittings, designed for types and sizes of raceway or cable to be supported.
- D. Support for Conductors in Vertical Conduit: Factory-fabricated assembly consisting of threaded body and insulating wedging plug or plugs for non-armored electrical conductors or cables in riser conduits. Plugs shall have number, size, and shape of conductor gripping pieces as required to suit individual conductors or cables supported. Body shall be malleable iron.
- E. Structural Steel for Fabricated Supports and Restraints: ASTM A 36/A 36M, steel plates, shapes, and bars; black and galvanized.
- F. Mounting, Anchoring, and Attachment Components: Items for fastening electrical items or their supports to building surfaces include the following:
 1. Powder-Actuated Fasteners: Threaded-steel stud, for use in hardened portland cement concrete, steel, or wood, with tension, shear, and pullout capacities appropriate for supported loads and building materials where used.
 - a. Manufacturers: Subject to compliance with requirements, provide products by one of the following:
 - 1) Hilti Inc.
 - 2) ITW Ramset/Red Head; a division of Illinois Tool Works, Inc.
 - 3) MKT Fastening, LLC.
 - 4) Simpson Strong-Tie Co., Inc.; Masterset Fastening Systems Unit.
 2. Mechanical-Expansion Anchors: Insert-wedge-type, stainless steel, for use in hardened portland cement concrete with tension, shear, and pullout capacities appropriate for supported loads and building materials in which used.
 - a. Manufacturers: Subject to compliance with requirements, provide products by one of the following:
 - 1) Cooper B-Line, Inc.; a division of Cooper Industries.
 - 2) Empire Tool and Manufacturing Co., Inc.
 - 3) Hilti Inc.
 - 4) ITW Ramset/Red Head; a division of Illinois Tool Works, Inc.
 - 5) MKT Fastening, LLC.
 3. Concrete Inserts: Steel or malleable-iron, slotted support system units similar to MSS Type 18; complying with MFMA-4 or MSS SP-58.
 4. Clamps for Attachment to Steel Structural Elements: MSS SP-58, type suitable for attached structural element.
 5. Through Bolts: Structural type, hex head, and high strength. Comply with ASTM A 325.
 6. Toggle Bolts: All-steel springhead type.
 7. Hanger Rods: Threaded steel.

2.2 FABRICATED METAL EQUIPMENT SUPPORT ASSEMBLIES

- A. Description: Welded or bolted, structural-steel shapes, shop or field fabricated to fit dimensions of supported equipment.
- B. Materials: Comply with requirements in Division 05 Section "Metal Fabrications" for steel shapes and plates.

PART 3 - EXECUTION

3.1 APPLICATION

- A. Comply with NECA 1 and NECA 101 for application of hangers and supports for electrical equipment and systems except if requirements in this Section are stricter.
- B. Maximum Support Spacing and Minimum Hanger Rod Size for Raceway: Space supports for EMT, and RMC as required by NFPA 70. Minimum rod size shall be 1/4 inch (6 mm) in diameter.
- C. Multiple Raceways or Cables: Install trapeze-type supports fabricated with steel slotted support system, sized so capacity can be increased by at least 25 percent in future without exceeding specified design load limits.
 - 1. Secure raceways and cables to these supports with two-bolt conduit clamps .
- D. Spring-steel clamps designed for supporting single conduits without bolts may be used for 1-1/2-inch (38-mm) and smaller raceways serving branch circuits and communication systems above suspended ceilings and for fastening raceways to trapeze supports.

3.2 SUPPORT INSTALLATION

- A. Comply with NECA 1 and NECA 101 for installation requirements except as specified in this Article.
- B. Raceway Support Methods: In addition to methods described in NECA 1, EMT and RMC may be supported by openings through structure members, as permitted in NFPA 70.
- C. Strength of Support Assemblies: Where not indicated, select sizes of components so strength will be adequate to carry present and future static loads within specified loading limits. Minimum static design load used for strength determination shall be weight of supported components plus 200 lb (90 kg).
- D. Mounting and Anchorage of Surface-Mounted Equipment and Components: Anchor and fasten electrical items and their supports to building structural elements by the following methods unless otherwise indicated by code:
 - 1. To Wood: Fasten with lag screws or through bolts.
 - 2. To New Concrete: Bolt to concrete inserts.
 - 3. To Masonry: Approved toggle-type bolts on hollow masonry units and expansion anchor fasteners on solid masonry units.
 - 4. To Existing Concrete: Expansion anchor fasteners.
 - 5. Instead of expansion anchors, powder-actuated driven threaded studs provided with lock washers and nuts may be used in existing standard-weight concrete 4 inches (100 mm) thick or greater. Do not use for anchorage to

lightweight-aggregate concrete or for slabs less than 4 inches (100 mm) thick.

6. To Steel: Beam clamps (MSS Type 19, 21, 23, 25, or 27) complying with MSS SP-69.
7. To Light Steel: Sheet metal screws.
8. Items Mounted on Hollow Walls and Nonstructural Building Surfaces: Mount cabinets, panelboards, disconnect switches, control enclosures, pull and junction boxes, transformers, and other devices on slotted-channel racks attached to substrate by means that meet seismic-restraint strength and anchorage requirements.

- E. Drill holes for expansion anchors in concrete at locations and to depths that avoid reinforcing bars.

3.3 INSTALLATION OF FABRICATED METAL SUPPORTS

- A. Comply with installation requirements in Section "Metal Fabrications" for site-fabricated metal supports.
- B. Cut, fit, and place miscellaneous metal supports accurately in location, alignment, and elevation to support and anchor electrical materials and equipment.
- C. Field Welding: Comply with AWS D1.1/D1.1M.

3.4 CONCRETE BASES

- A. Construct concrete bases of dimensions indicated but not less than 4 inches (100 mm) larger in both directions than supported unit, and so anchors will be a minimum of 10 bolt diameters from edge of the base.
- B. Use 3000-psi (20.7-MPa), 28-day compressive-strength concrete. Concrete materials, reinforcement, and placement requirements are specified in Division 03 Section "Cast-in-Place Concrete."
- C. Anchor equipment to concrete base.
 1. Place and secure anchorage devices. Use supported equipment manufacturer's setting drawings, templates, diagrams, instructions, and directions furnished with items to be embedded.
 2. Install anchor bolts to elevations required for proper attachment to supported equipment.
 3. Install anchor bolts according to anchor-bolt manufacturer's written instructions.

3.5 PAINTING

- A. Touchup: Clean field welds and abraded areas of shop paint. Paint exposed areas immediately after erecting hangers and supports. Use same materials as used for shop painting. Comply with SSPC-PA 1 requirements for touching up field-painted surfaces.
 1. Apply paint by brush or spray to provide minimum dry film thickness of 2.0 mils (0.05 mm).
- B. Touchup: Comply with requirements in painting Sections for cleaning and touchup painting of field welds, bolted connections, and abraded areas of shop paint on miscellaneous metal.

- C. Galvanized Surfaces: Clean welds, bolted connections, and abraded areas and apply galvanizing-repair paint to comply with ASTM A 780.

END OF SECTION

SECTION 26 05 33

RACEWAY AND BOXES FOR ELECTRICAL SYSTEMS

PART 1 - GENERAL

1.1 RELATED DOCUMENTS

- A. Drawings and general provisions of the Contract, including General and Supplementary Conditions and Division 01 Specification Sections, apply to this Section.
- B. Section 01 81 13 "Sustainable Design Requirements – LEED v4 for Building Design & Construction – New Construction" for sustainable design requirements and detailed sustainable design submittal requirements.
- C. Section 01 74 19 "Construction and Demolition Waste Management and Disposal" for disposal of construction, demolition and packaging waste disposal requirements.

1.2 SUMMARY

- A. This Section includes raceways, fittings, boxes, enclosures, and cabinets for electrical wiring.
- B. Related Sections include the following:
 - 1. Division 26 Section "Underground Ducts and Raceways for Electrical Systems" for exterior ductbanks, manholes, and underground utility construction.
- C. Sustainable Building Requirements:
 - 1. The Owner requires the Contractor to implement practices and procedures to meet the project's environmental performance goals, which include achieving LEED version 4 Certified level Certification. Specific project goals that may impact this area of work include: use of recycled-content materials; use of locally-manufactured materials; use of low-emitting materials; construction waste recycling; and the implementation of a construction indoor air quality management plan. The Contractor shall ensure that the requirements related to these goals, as defined in the Articles below, are implemented to the fullest extent. Substitutions, or other changes to the work proposed by the Contractor or their Subcontractors, shall not be allowed if such changes compromise the aforementioned environmental goals and LEED certification.

1.3 DEFINITIONS

- A. EMT: Electrical metallic tubing.
- B. EPDM: Ethylene-propylene-diene terpolymer rubber.
- C. FMC: Flexible metal conduit.
- D. LFMC: Liquidtight flexible metal conduit.
- E. LFNC: Liquidtight flexible nonmetallic conduit.

- F. NBR: Acrylonitrile-butadiene rubber.
- G. RNC: Rigid nonmetallic conduit.

1.4 SUBMITTALS

- A. Product Data: For surface raceways, wireways and fittings, floor boxes, hinged-cover enclosures, and cabinets.
- B. Shop Drawings: For the following raceway components. Include plans, elevations, sections, details, and attachments to other work.
 - 1. Custom enclosures and cabinets.
 - 2. For handholes and boxes for underground wiring, including the following:
 - a. Duct entry provisions, including locations and duct sizes.
 - b. Frame and cover design.
 - c. Grounding details.
 - d. Dimensioned locations of cable rack inserts, and pulling-in and lifting irons.
 - e. Joint details.
- C. Samples for Initial Selection: For wireways and surface raceways with factory-applied texture and color finishes.
 - 1. Size: As requested by Owner or Architect minimum of 4 samples.
- D. Samples for Verification: For each type of exposed finish required for wireways and surface raceways, prepared on Samples of size indicated below.
 - 1. Size: As requested by Owner or Architect minimum of 4 samples.
- E. Coordination Drawings: Conduit routing plans, drawn to scale, on which the following items are shown and coordinated with each other, based on input from installers of the items involved:
 - 1. Structural members in the paths of conduit groups with common supports.
 - 2. HVAC and plumbing items and architectural features in the paths of conduit groups with common supports.
- F. Manufacturer Seismic Qualification Certification: Submit certification that enclosures and cabinets and their mounting provisions, including those for internal components, will withstand seismic forces defined in Division 26 Section "Vibration and Seismic Controls for Electrical Systems." Include the following:
 - 1. Basis for Certification: Indicate whether withstand certification is based on actual test of assembled components or on calculation.
 - a. The term "withstand" means "the cabinet or enclosure will remain in place without separation of any parts when subjected to the seismic forces specified and the unit will retain its enclosure characteristics, including its interior accessibility, after the seismic event."
 - 2. Dimensioned Outline Drawings of Equipment Unit: Identify center of gravity and locate and describe mounting and anchorage provisions.
 - 3. Detailed description of equipment anchorage devices on which the certification is based and their installation requirements.
- G. Qualification Data: For professional engineer and testing agency.
- H. Source quality-control test reports.

1.5 QUALITY ASSURANCE

- A. Electrical Components, Devices, and Accessories: Listed and labeled as defined in NFPA 70, Article 100, by a testing agency acceptable to authorities having jurisdiction, and marked for intended use.
- B. Comply with NFPA 70.

PART 2 - PRODUCTS

2.1 METAL CONDUIT AND TUBING

- A. Manufacturers: Subject to compliance with requirements, provide products by one of the following:
 - 1. AFC Cable Systems, Inc.
 - 2. Alflex Inc.
 - 3. Allied Tube & Conduit; a Tyco International Ltd. Co.
 - 4. Anamet Electrical, Inc.; Anaconda Metal Hose.
 - 5. Electri-Flex Co.
 - 6. Maverick Tube Corporation.
 - 7. O-Z Gedney; a unit of General Signal.
 - 8. Wheatland Tube Company.
- B. Rigid Steel Conduit: ANSI C80.1.
- C. Aluminum Rigid Conduit: ANSI C80.5.
- D. IMC: ANSI C80.6.
- E. PVC-Coated Steel Conduit: PVC-coated rigid steel conduit.
 - 1. Comply with NEMA RN 1.
 - 2. Coating Thickness: 0.040 inch (1 mm), minimum.
- F. EMT: ANSI C80.3., Color Coded to MMC Standards.
- G. FMC: Zinc-coated steel or aluminum.
- H. LFMC: Flexible steel conduit with PVC jacket.
- I. Fittings for Conduit (Including all Types and Flexible and Liquidtight), EMT, and Cable: NEMA FB 1; listed for type and size raceway with which used, and for application and environment in which installed.
 - 1. Conduit Fittings for Hazardous (Classified) Locations: Comply with UL 886.
 - 2. Fittings for EMT: Steel or die-cast, set-screw or compression type.
 - 3. Coating for Fittings for PVC-Coated Conduit: Minimum thickness, 0.040 inch (1 mm), with overlapping sleeves protecting threaded joints.
- J. Joint Compound for Rigid Steel Conduit: Listed for use in cable connector assemblies, and compounded for use to lubricate and protect threaded raceway joints from corrosion and enhance their conductivity.

2.2 NONMETALLIC CONDUIT AND TUBING

- A. Manufacturers: Subject to compliance with requirements, provide products by one of the following:
 - 1. AFC Cable Systems, Inc.
 - 2. Anamet Electrical, Inc.; Anaconda Metal Hose.

3. Arcco Corporation.
4. CANTEX Inc.
5. CertainTeed Corp.; Pipe & Plastics Group.
6. Condux International, Inc.
7. ElecSYS, Inc.
8. Electri-Flex Co.
9. Lamson & Sessions; Carlon Electrical Products.
10. RACO; a Hubbell Company.
11. Thomas & Betts Corporation.

- B. RNC: NEMA TC 2, Type EPC-40-PVC, unless otherwise indicated.
- C. LFNC: UL 1660.
- D. Fittings for and RNC: NEMA TC 3; match to conduit or tubing type and material.
- E. Fittings for LFNC: UL 514B.

2.3 METAL WIREWAYS

- A. Manufacturers: Subject to compliance with requirements, provide products by one of the following:
 1. Cooper B-Line, Inc.
 2. Hoffman.
 3. Square D; Schneider Electric.
- B. Description: Sheet metal sized and shaped as indicated, NEMA 250, Type 1, unless otherwise indicated.
- C. Fittings and Accessories: Include couplings, offsets, elbows, expansion joints, adapters, hold-down straps, end caps, and other fittings to match and mate with wireways as required for complete system.
- D. Wireway Covers: Hinged type, Flanged-and-gasketed type where indicated or required by code or location of installation.
- E. Finish: Manufacturer's standard enamel finish.

2.4 NONMETALLIC WIREWAYS

- A. Manufacturers: Subject to compliance with requirements, provide products by one of the following:
 1. Hoffman.
 2. Lamson & Sessions; Carlon Electrical Products.
- B. Description: PVC plastic, extruded and fabricated to size and shape indicated, with snap-on cover and mechanically coupled connections with plastic fasteners.
- C. Fittings and Accessories: Include couplings, offsets, elbows, expansion joints, adapters, hold-down straps, end caps, and other fittings to match and mate with wireways as required for complete system.

2.5 SURFACE RACEWAYS

- A. Surface Metal Raceways: Galvanized steel with snap-on covers. Manufacturer's standard enamel finish in color selected by Architect.

1. Manufacturers: Subject to compliance with requirements, provide products by one of the following:
 - a. Thomas & Betts Corporation.
 - b. Walker Systems, Inc.; Wiremold Company (The).
 - c. Wiremold Company (The); Electrical Sales Division.

2.6 BOXES, ENCLOSURES, AND CABINETS

- A. Manufacturers: Subject to compliance with requirements, provide products by one of the following:
 1. Cooper Crouse-Hinds; Div. of Cooper Industries, Inc.
 2. EGS/Appleton Electric.
 3. Erickson Electrical Equipment Company.
 4. Hoffman.
 5. Hubbell Incorporated; Killark Electric Manufacturing Co. Division.
 6. O-Z/Gedney; a unit of General Signal.
 7. RACO; a Hubbell Company.
 8. Thomas & Betts Corporation.
 9. Walker Systems, Inc.; Wiremold Company (The).
- B. Sheet Metal Outlet and Device Boxes: NEMA OS 1.
- C. Cast-Metal Outlet and Device Boxes: NEMA FB 1, ferrous alloy or aluminum, Type FD, with gasketed cover.
- D. Nonmetallic Outlet and Device Boxes: NEMA OS 2.
- E. Metal Floor Boxes: Cast or sheet metal, fully adjustable, rectangular.
- F. Nonmetallic Floor Boxes: Nonadjustable, round.
- G. Small Sheet Metal Pull and Junction Boxes: NEMA OS 1.
- H. Cast-Metal Access, Pull, and Junction Boxes: NEMA FB 1, cast aluminum or galvanized, cast iron with gasketed cover.
- I. Hinged-Cover Enclosures: NEMA 250, Type 1, with continuous-hinge cover with flush latch, unless otherwise indicated.
 1. Metal Enclosures: Steel, finished inside and out with manufacturer's standard enamel.
 2. Nonmetallic Enclosures: Plastic, finished inside with radio-frequency-resistant paint.
- J. Cabinets:
 1. NEMA 250, Type 1, galvanized-steel box with removable interior panel and removable front, finished inside and out with manufacturer's standard enamel.
 2. Hinged door in front cover with flush latch and concealed hinge.
 3. Key latch to match panelboards.
 4. Metal barriers to separate wiring of different systems and voltage.
 5. Accessory feet where required for freestanding equipment.

2.7 SLEEVES FOR RACEWAYS

- A. Steel Pipe Sleeves: ASTM A 53/A 53M, Type E, Grade B, Schedule 40, galvanized steel, plain ends.

- B. Cast-Iron Pipe Sleeves: Cast or fabricated "wall pipe," equivalent to ductile-iron pressure pipe, with plain ends and integral waterstop, unless otherwise indicated.
- C. Sleeves for Rectangular Openings: Galvanized sheet steel with minimum 0.052- or 0.138-inch (1.3- or 3.5-mm) thickness as indicated and of length to suit application.
- D. Coordinate sleeve selection and application with selection and application of firestopping specified in Division 07 Section "Penetration Firestopping."

2.8 SLEEVE SEALS

- A. Manufacturers: Subject to compliance with requirements, provide products by one of the following:
 - 1. Advance Products & Systems, Inc.
 - 2. Calpico, Inc.
 - 3. Metraflex Co.
 - 4. Pipeline Seal and Insulator, Inc.
- B. Description: Modular sealing device, designed for field assembly, to fill annular space between sleeve and cable.
 - 1. Sealing Elements: NBR interlocking links shaped to fit surface of cable or conduit. Include type and number required for material and size of raceway or cable.
 - 2. Pressure Plates: Stainless steel. Include two for each sealing element.
 - 3. Connecting Bolts and Nuts: Stainless steel of length required to secure pressure plates to sealing elements. Include one for each sealing element.

2.9 SOURCE QUALITY CONTROL FOR UNDERGROUND ENCLOSURES

- A. Handhole and Pull-Box Prototype Test: Test prototypes of handholes and boxes for compliance with SCTE 77. Strength tests shall be for specified tier ratings of products supplied.
 - 1. Tests of materials shall be performed by a independent testing agency.
 - 2. Strength tests of complete boxes and covers shall be by either an independent testing agency or manufacturer. A qualified registered professional engineer shall certify tests by manufacturer.
 - 3. Testing machine pressure gages shall have current calibration certification complying with ISO 9000 and ISO 10012, and traceable to NIST standards.

PART 3 - EXECUTION

3.1 RACEWAY APPLICATION

- A. Outdoors: Apply raceway products as specified below, unless otherwise indicated:
 - 1. Exposed Conduit: Rigid steel conduit.
 - 2. Concealed Conduit, Aboveground: Rigid steel conduit.
 - 3. Underground Conduit: RNC, Type EPC-80-PVC.
 - 4. Connection to Vibrating Equipment (Including Transformers and Hydraulic, Pneumatic, Electric Solenoid, or Motor-Driven Equipment): LFMC or LFNC.
 - 5. Boxes and Enclosures, Aboveground: NEMA 250, Type 4.
 - 6. Application of Handholes and Boxes for Underground Wiring:

- a. Pull Boxes in Driveway, Parking Lot, and Off-Roadway Locations, Subject to Occasional, Nondeliberate Loading by Heavy Vehicles: Fiberglass enclosures with polymer-concrete frame and cover, SCTE 77, Tier 15 structural load rating.
 - b. Pull Boxes in Sidewalk and Similar Applications with a Safety Factor for Nondeliberate Loading by Vehicles: Heavy-duty fiberglass units with polymer-concrete frame and cover, SCTE 77, Tier 8 structural load rating.
 - c. Pull Boxes Subject to Light-Duty Pedestrian Traffic Only: Fiberglass-reinforced polyester resin, structurally tested according to SCTE 77 with 3000-lbf (13 345-N) vertical loading.
- B. Comply with the following indoor applications, unless otherwise indicated:
1. Exposed, Not Subject to Physical Damage: EMT.
 2. Exposed, Not Subject to Severe Physical Damage: EMT.
 3. Exposed and Subject to Severe Physical Damage: Rigid steel conduit. Includes raceways in the following locations:
 - a. Loading dock.
 - b. Corridors used for traffic of mechanized carts, forklifts, and pallet-handling units.
 - c. Mechanical rooms.
 4. Concealed in Ceilings and Interior Walls and Partitions: EMT.
 5. Connection to Vibrating Equipment (Including Transformers and Hydraulic, Pneumatic, Electric Solenoid, or Motor-Driven Equipment): FMC, except use LFMC in damp or wet locations.
 6. Damp or Wet Locations: Rigid steel conduit
 7. Boxes and Enclosures: NEMA 250, Type 1, except use NEMA 250, Type 4, stainless steel in damp or wet locations.
- C. Minimum Raceway Size: 3/4-inch (21-mm) trade size.
- D. Raceway Fittings: Compatible with raceways and suitable for use and location.
1. Rigid Steel Conduit: Use threaded rigid steel conduit fittings, unless otherwise indicated.
 2. PVC Externally Coated, Rigid Steel Conduits: Use only fittings listed for use with that material. Patch and seal all joints, nicks, and scrapes in PVC coating after installing conduits and fittings. Use sealant recommended by fitting manufacturer.
- E. Install nonferrous conduit or tubing for circuits operating above 60 Hz. Where aluminum raceways are installed for such circuits and pass through concrete, install in nonmetallic sleeve.
- F. Do not install aluminum conduits in contact with concrete.
- ### 3.2 INSTALLATION
- A. Comply with NECA 1 for installation requirements applicable to products specified in Part 2 except where requirements on Drawings or in this Article are stricter.
 - B. Keep raceways at least 6 inches (150 mm) away from parallel runs of flues and steam or hot-water pipes. Install horizontal raceway runs above water and steam piping.
 - C. Complete raceway installation before starting conductor installation.

- D. Support raceways as specified in Division 26 Section "Hangers and Supports for Electrical Systems."
- E. Arrange stub-ups so curved portions of bends are not visible above the finished slab.
- F. Install no more than the equivalent of three 90-degree bends in any conduit run except for communications conduits, for which fewer bends are allowed.
- G. Conceal conduit and EMT within finished walls, ceilings, and floors, unless otherwise indicated.
- H. Raceways Embedded in Slabs:
 - 1. Run conduit larger than 1-inch (27-mm) trade size, parallel or at right angles to main reinforcement. Where at right angles to reinforcement, place conduit close to slab support.
 - 2. Arrange raceways to cross building expansion joints at right angles with expansion fittings.
 - 3. Change from RNC, Type EPC-40-PVC, to rigid steel conduit, or before rising above the floor
- I. Threaded Conduit Joints, Exposed to Wet, Damp, Corrosive, or Outdoor Conditions: Apply listed compound to threads of raceway and fittings before making up joints. Follow compound manufacturer's written instructions.
- J. Raceway Terminations at Locations Subject to Moisture or Vibration: Use insulating bushings to protect conductors, including conductors smaller than No. 4 AWG.
- K. Install pull wires in empty raceways. Use polypropylene or monofilament plastic line with not less than 200-lb (90-kg) tensile strength. Leave at least 12 inches (300 mm) of slack at each end of pull wire.
- L. Raceways for Optical Fiber and Communications Cable: Install raceways, metallic and nonmetallic, rigid and flexible, as follows:
 - 1. 3/4-Inch (19-mm) Trade Size and Smaller: Install raceways in maximum lengths of 50 feet (15 m).
 - 2. 1-Inch (25-mm) Trade Size and Larger: Install raceways in maximum lengths of 75 feet (23 m).
 - 3. Install with a maximum of two 90-degree bends or equivalent for each length of raceway unless Drawings show stricter requirements. Separate lengths with pull or junction boxes or terminations at distribution frames or cabinets where necessary to comply with these requirements.
- M. Install raceway sealing fittings at suitable, approved, and accessible locations and fill them with listed sealing compound. For concealed raceways, install each fitting in a flush steel box with a blank cover plate having a finish similar to that of adjacent plates or surfaces. Install raceway sealing fittings at the following points:
 - 1. Where conduits pass from warm to cold locations, such as boundaries of refrigerated spaces.
 - 2. Where otherwise required by NFPA 70.
- N. Expansion-Joint Fittings for RNC: Install in each run of aboveground conduit that is located where environmental temperature change may exceed 30 deg F (17 deg C), and that has straight-run length that exceeds 25 feet (7.6 m).
 - 1. Install expansion-joint fittings for each of the following locations, and provide type and quantity of fittings that accommodate temperature change listed for location:

- a. Outdoor Locations Not Exposed to Direct Sunlight: 125 deg F (70 deg C) temperature change.
 - b. Outdoor Locations Exposed to Direct Sunlight: 155 deg F (86 deg C) temperature change.
 - c. Indoor Spaces: Connected with the Outdoors without Physical Separation: 125 deg F (70 deg C) temperature change.
 - d. Attics: 135 deg F (75 deg C) temperature change.
2. Install fitting(s) that provide expansion and contraction for at least 0.00041 inch per foot of length of straight run per deg F (0.06 mm per meter of length of straight run per deg C) of temperature change.
 3. Install each expansion-joint fitting with position, mounting, and piston setting selected according to manufacturer's written instructions for conditions at specific location at the time of installation.
- O. Flexible Conduit Connections: Use maximum of 72 inches (1830 mm) of flexible conduit for recessed and semirecessed lighting fixtures normal branch lighting only, equipment subject to vibration, noise transmission, or movement; and for transformers and motors.
1. Use LFMC in damp or wet locations subject to severe physical damage.
 2. Use LFMC or LFNC in damp or wet locations not subject to severe physical damage.
- P. Recessed Boxes in Masonry Walls: Saw-cut opening for box in center of cell of masonry block, and install box flush with surface of wall.
- Q. Set metal floor boxes level and flush with finished floor surface.
- R. Set nonmetallic floor boxes level. Trim after installation to fit flush with finished floor surface.
- ### 3.3 SLEEVE INSTALLATION FOR ELECTRICAL PENETRATIONS
- A. Coordinate sleeve selection and application with selection and application of firestopping specified in Division 07 Section "Penetration Firestopping."
- B. Concrete Slabs and Walls: Install sleeves for penetrations unless core-drilled holes or formed openings are used. Install sleeves during erection of slabs and walls.
- C. Use pipe sleeves unless penetration arrangement requires rectangular sleeved opening.
- D. Rectangular Sleeve Minimum Metal Thickness:
1. For sleeve cross-section rectangle perimeter less than 50 inches (1270 mm) and no side greater than 16 inches (400 mm), thickness shall be 0.052 inch (1.3 mm).
 2. For sleeve cross-section rectangle perimeter equal to, or greater than, 50 inches (1270 mm) and 1 or more sides equal to, or greater than, 16 inches (400 mm), thickness shall be 0.138 inch (3.5 mm).
- E. Fire-Rated Assemblies: Install sleeves for penetrations of fire-rated floor and wall assemblies unless openings compatible with firestop system used are fabricated during construction of floor or wall.
- F. Cut sleeves to length for mounting flush with both surfaces of walls.
- G. Extend sleeves installed in floors 2 inches (50 mm) above finished floor level.

- H. Size pipe sleeves to provide 1/4-inch (6.4-mm) annular clear space between sleeve and raceway unless sleeve seal is to be installed or unless seismic criteria require different clearance.
- I. Seal space outside of sleeves with grout for penetrations of concrete and masonry and with approved joint compound for gypsum board assemblies.
- J. Interior Penetrations of Non-Fire-Rated Walls and Floors: Seal annular space between sleeve and raceway, using joint sealant appropriate for size, depth, and location of joint. Refer to Division 07 Section "Joint Sealants" for materials and installation.
- K. Fire-Rated-Assembly Penetrations: Maintain indicated fire rating of walls, partitions, ceilings, and floors at raceway penetrations. Install sleeves and seal with firestop materials. Comply with Division 07 Section "Penetration Firestopping."
- L. Roof-Penetration Sleeves: Seal penetration of individual raceways with flexible, boot-type flashing units applied in coordination with roofing work.
- M. Aboveground, Exterior-Wall Penetrations: Seal penetrations using sleeves and mechanical sleeve seals. Select sleeve size to allow for 1-inch (25-mm) annular clear space between pipe and sleeve for installing mechanical sleeve seals.
- N. Underground, Exterior-Wall Penetrations: Install cast-iron "wall pipes" for sleeves. Size sleeves to allow for 1-inch (25-mm) annular clear space between raceway and sleeve for installing mechanical sleeve seals.

3.4 SLEEVE-SEAL INSTALLATION

- A. Install to seal underground, exterior wall penetrations.
- B. Use type and number of sealing elements recommended by manufacturer for raceway material and size. Position raceway in center of sleeve. Assemble mechanical sleeve seals and install in annular space between raceway and sleeve. Tighten bolts against pressure plates that cause sealing elements to expand and make watertight seal.

3.5 FIRESTOPPING

- A. Apply firestopping to electrical penetrations of fire-rated floor and wall assemblies to restore original fire-resistance rating of assembly. Firestopping materials and installation requirements are specified in Division 07 Section "Penetration Firestopping."

3.6 PROTECTION

- A. Provide final protection and maintain conditions that ensure coatings, finishes, and cabinets are without damage or deterioration at time of Substantial Completion.
 - 1. Repair damage to galvanized finishes with zinc-rich paint recommended by manufacturer.
 - 2. Repair damage to PVC or paint finishes with matching touchup coating recommended by manufacturer.

END OF SECTION

SECTION 26 05 53

IDENTIFICATION FOR ELECTRICAL SYSTEMS

PART 1 - GENERAL

1.1 RELATED DOCUMENTS

- A. Drawings and general provisions of the Contract, including General and Supplementary Conditions and Division 01 Specification Sections, apply to this Section.
- B. Section 01 81 13 "Sustainable Design Requirements – LEED v4 for Building Design & Construction – New Construction" for sustainable design requirements and detailed sustainable design submittal requirements.
- C. Section 01 74 19 "Construction and Demolition Waste Management and Disposal" for disposal of construction, demolition and packaging waste disposal requirements.

1.2 SUMMARY

- A. This Section includes the following:
 - 1. Identification for raceway and metal-clad cable.
 - 2. Identification for conductors and communication and control cable.
 - 3. Underground-line warning tape.
 - 4. Warning labels and signs.
 - 5. Instruction signs.
 - 6. Equipment identification labels.
 - 7. Miscellaneous identification products.
- B. Sustainable Building Requirements:
 - 1. The Owner requires the Contractor to implement practices and procedures to meet the project's environmental performance goals, which include achieving LEED version 4 Certified level Certification. Specific project goals that may impact this area of work include: use of recycled-content materials; use of locally-manufactured materials; use of low-emitting materials; construction waste recycling; and the implementation of a construction indoor air quality management plan. The Contractor shall ensure that the requirements related to these goals, as defined in the Articles below, are implemented to the fullest extent. Substitutions, or other changes to the work proposed by the Contractor or their Subcontractors, shall not be allowed if such changes compromise the aforementioned environmental goals and LEED certification.

1.3 SUBMITTALS

- A. Product Data: For each electrical identification product indicated.
- B. Identification Schedule: An index of nomenclature of electrical equipment and system components used in identification signs and labels.

- C. Samples: For each type of label and sign to illustrate size, colors, lettering style, mounting provisions, and graphic features of identification products.

1.4 QUALITY ASSURANCE

- A. Comply with ANSI A13.1 and ANSI C2.
- B. Comply with NFPA 70.
- C. Comply with 29 CFR 1910.145.

1.5 COORDINATION

- A. Coordinate identification names, abbreviations, colors, and other features with requirements in the Contract Documents, Shop Drawings, manufacturer's wiring diagrams, and the Operation and Maintenance Manual, and with those required by codes, standards, and 29 CFR 1910.145. Use consistent designations throughout Project.
- B. Coordinate installation of identifying devices with completion of covering and painting of surfaces where devices are to be applied.
- C. Coordinate installation of identifying devices with location of access panels and doors.
- D. Install identifying devices before installing acoustical ceilings and similar concealment.

PART 2 - PRODUCTS

2.1 RACEWAY AND METAL-CLAD CABLE IDENTIFICATION MATERIALS

- A. Comply with ANSI A13.1 for minimum size of letters for legend and for minimum length of color field for each raceway and cable size.
- B. Color for Printed Legend:
 - 1. Power Circuits: Black letters on an orange field.
 - 2. Legend: Indicate system or service and voltage, if applicable.
- C. Snap-Around Labels: Slit, pretensioned, flexible, preprinted, color-coded acrylic sleeves, with diameter sized to suit diameter of raceway or cable it identifies and to stay in place by gripping action.
- D. Snap-Around, Color-Coding Bands: Slit, pretensioned, flexible, solid-colored acrylic sleeves, 2 inches (50 mm) long, with diameter sized to suit diameter of raceway or cable it identifies and to stay in place by gripping action.
- E. Self-Adhesive Vinyl Tape: Colored, heavy duty, waterproof, fade resistant; 2 inches (50 mm) wide; compounded for outdoor use.

2.2 CONDUCTOR AND COMMUNICATION- AND CONTROL-CABLE IDENTIFICATION MATERIALS

- A. Color-Coding Conductor Tape: Colored, self-adhesive vinyl tape not less than 3 mils (0.08 mm) thick by 1 to 2 inches (25 to 50 mm) wide.

- B. Marker Tapes: Vinyl or vinyl-cloth, self-adhesive wraparound type, with circuit identification legend machine printed by thermal transfer or equivalent process.
- C. Write-On Tags: Polyester tag, 0.015 inch (0.38 mm) thick, with corrosion-resistant grommet and polyester or nylon tie for attachment to conductor or cable.
 - 1. Marker for Tags: Permanent, waterproof, black ink marker recommended by tag manufacturer.

2.3 UNDERGROUND-LINE WARNING TAPE

- A. Description: Permanent, bright-colored, continuous-printed, polyethylene tape.
 - 1. Not less than 6 inches (150 mm) wide by 4 mils (0.102 mm) thick.
 - 2. Compounded for permanent direct-burial service.
 - 3. Embedded continuous metallic strip or core.
 - 4. Printed legend shall indicate type of underground line.

2.4 WARNING LABELS AND SIGNS

- A. Comply with NFPA 70 and 29 CFR 1910.145.
- B. Baked-Enamel Warning Signs: Preprinted aluminum signs, punched or drilled for fasteners, with colors, legend, and size required for application. 1/4-inch (6.4-mm) grommets in corners for mounting. Nominal size, 7 by 10 inches (180 by 250 mm).
- C. Metal-Backed, Butyrate Warning Signs: Weather-resistant, nonfading, preprinted, cellulose-acetate butyrate signs with 0.0396-inch (1-mm) galvanized-steel backing; and with colors, legend, and size required for application. 1/4-inch (6.4-mm) grommets in corners for mounting. Nominal size, 10 by 14 inches (250 by 360 mm).
- D. Warning label and sign shall include, but are not limited to, the following legends:
 - 1. Multiple Power Source Warning: "DANGER - ELECTRICAL SHOCK HAZARD - EQUIPMENT HAS MULTIPLE POWER SOURCES."
 - 2. Workspace Clearance Warning: "WARNING - OSHA REGULATION - AREA IN FRONT OF ELECTRICAL EQUIPMENT MUST BE KEPT CLEAR FOR 36 INCHES (915 MM)."

2.5 INSTRUCTION SIGNS

- A. Engraved, laminated acrylic or melamine plastic, minimum 1/16 inch (1.6 mm) thick for signs up to 20 sq. in. (129 sq. cm) and 1/8 inch (3.2 mm) thick for larger sizes.
 - 1. Engraved legend with black letters on white face.
 - 2. Punched or drilled for mechanical fasteners.
 - 3. Framed with mitered acrylic molding and arranged for attachment at applicable equipment.

2.6 EQUIPMENT IDENTIFICATION LABELS

- A. Engraved, Laminated Acrylic or Melamine Label: Punched or drilled for screw mounting. White letters on a dark-gray background. Minimum letter height shall be 3/8 inch (10 mm). Name plate descriptions shall be as follows:
 - 1. Switchboard: Identify and switchboard main breaker as such and feeder breakers by panelboard, transformer and equipment FED

- a. Example: SWBD 4A, PANEL DP2G
480/277 V, 3 PH, 4W
2. Panelboards: Identify with panel designation and characteristics.
 - a. Example: DP2G
480/277 V, 3 PH, 4W
3. Low Voltage Transformers: Identify with source of power.
 - a. Example: FED from SWBD N-1
4. Enclosed Breakers and Disconnect Switches: Identify with equipment served.
 - a. Example: CWP-1
5. Transfer Switches: Identify by designation and indicate generator location.
 - a. Example: ATS-EM
Generator located North side of Building.
6. Signs:
 - a. Provide a nameplate on the service entrance section that indicated location of on-site emergency power source.
 - 1) Example: Emergency Generator located southwest corner of building.
 - b. Provide a nameplate at the generator grounding location if the emergency source is a separately derived system and is connected to a grounding electrode at a location that is remote from the emergency source.
 - 1) Example: Generator grounding location connection.
 - c. Provide a nameplate next to the generator ground fault sensor that states instructions on the course of action to be taken in event of indicated ground fault.

2.7 MISCELLANEOUS IDENTIFICATION PRODUCTS

- A. Cable Ties: Fungus-inert, self-extinguishing, 1-piece, self-locking, Type 6/6 nylon cable ties.
 1. Minimum Width: 3/16 inch (5 mm).
 2. Tensile Strength: 50 lb (22.6 kg), minimum.
 3. Temperature Range: Minus 40 to plus 185 deg F (Minus 40 to plus 85 deg C).
 4. Color: Black, except where used for color-coding.
- B. Paint: Paint materials and application requirements are specified in Division 09 painting Sections.
 1. Exterior Ferrous Metal:
 - a. Semigloss Alkyd-Enamel Finish: Two finish coat(s) over a primer.
 - 1) Primer: Exterior ferrous-metal primer.
 - 2) Finish Coats: Exterior semigloss alkyd enamel.
 2. Exterior Zinc-Coated Metal (except Raceways):
 - a. Semigloss Alkyd-Enamel Finish: Two finish coat(s) over a primer.
 - 1) Primer: Exterior zinc-coated metal primer.
 - 2) Finish Coats: Exterior semigloss alkyd enamel.
 3. Interior Ferrous Metal:
 - a. Semigloss Acrylic-Enamel Finish: One finish coat(s) over a primer.
 - 1) Primer: Interior ferrous-metal primer.
 - 2) Finish Coats: Interior semigloss acrylic enamel.
 4. Interior Zinc-Coated Metal (except Raceways):
 - a. Semigloss Acrylic-Enamel Finish: One finish coat(s) over a primer.
 - 1) Primer: Interior zinc-coated metal primer.
 - 2) Finish Coats: Interior semigloss acrylic enamel.

- C. Fasteners for Labels and Signs: Self-tapping, stainless-steel screws or stainless-steel machine screws with nuts and flat and lock washers.

PART 3 - EXECUTION

3.1 APPLICATION

- A. Accessible Raceways and Metal-Clad Cables, 600 V or Less, for Service, Feeder, and Branch Circuits More Than 30 A: Identify with orange snap-around label.
- B. Accessible Raceways and Cables of Auxiliary Systems: Identify the following systems with color-coded, snap-around, color-coding bands:
 - 1. Fire Alarm System: Red.
 - 2. Fire-Suppression Supervisory and Control System: Red and yellow.
 - 3. Security System: Blue and yellow.
 - 4. Mechanical and Electrical Supervisory System: Green and blue.
 - 5. Telecommunication System: Green and yellow.
 - 6. Control Wiring: Green and red.
- C. Power-Circuit Conductor Identification: For primary and secondary conductors No. 1/0 AWG and larger in vaults, pull and junction boxes, manholes, and handholes use write-on tags. Identify source and circuit number of each set of conductors. For single conductor cables, identify phase in addition to the above.
- D. Branch-Circuit Conductor Identification: Where there are conductors for more than three branch circuits in same junction or pull box, use write-on tags. Identify each ungrounded conductor according to source and circuit number.
- E. Conductors to Be Extended in the Future: Attach write-on tags to conductors and list source and circuit number.
- F. Auxiliary Electrical Systems Conductor Identification: Identify field-installed alarm, control, signal, sound, intercommunications, voice, and data connections.
 - 1. Identify conductors, cables, and terminals in enclosures and at junctions, terminals, and pull points. Identify by system and circuit designation.
 - 2. Use system of marker tape designations that is uniform and consistent with system used by manufacturer for factory-installed connections.
 - 3. Coordinate identification with Project Drawings, manufacturer's wiring diagrams, and Operation and Maintenance Manual.
- G. Locations of Underground Lines: Identify with underground-line warning tape for power, lighting, communication, and control wiring and optical fiber cable. Install underground-line warning tape for both direct-buried cables and cables in raceway.
- H. Warning Labels for Indoor Cabinets, Boxes, and Enclosures for Power and Lighting: Comply with 29 CFR 1910.145 and apply baked-enamel warning signs. Identify system voltage with black letters on an orange background. Apply to exterior of door, cover, or other access.
 - 1. Equipment with Multiple Power or Control Sources: Apply to door or cover of equipment including, but not limited to, the following:
 - a. Power transfer switches.
 - b. Controls with external control power connections.
 - 2. Equipment Requiring Workspace Clearance According to NFPA 70: Unless otherwise indicated, apply to door or cover of equipment but not on flush panelboards and similar equipment in finished spaces.

- I. Instruction Signs:
 1. Operating Instructions: Install instruction signs to facilitate proper operation and maintenance of electrical systems and items to which they connect. Install instruction signs with approved legend where instructions are needed for system or equipment operation.
 2. Emergency Operating Instructions: Install instruction signs with white legend on a red background with minimum 3/8-inch- (10-mm-) high letters for emergency instructions at equipment used for power transfer.
- J. Equipment Identification Labels: On each unit of equipment, install unique designation label that is consistent with wiring diagrams, schedules, and Operation and Maintenance Manual. Apply labels to disconnect switches and protection equipment, central or master units, control panels, control stations, terminal cabinets, and racks of each system. Systems include power, lighting, control, communication, signal, monitoring, and alarm systems unless equipment is provided with its own identification.
 1. Labeling Instructions:
 - a. Indoor Equipment: Engraved, laminated acrylic or melamine label. Unless otherwise indicated, provide a single line of text with 1/2-inch- (13-mm-) high letters on 1-1/2-inch- (38-mm-) high label; where 2 lines of text are required, use labels 2 inches (50 mm) high.
 - b. Outdoor Equipment: Engraved, laminated acrylic or melamine label.
 - c. Elevated Components: Increase sizes of labels and letters to those appropriate for viewing from the floor.
 2. Equipment to Be Labeled: All equipment requires a label 94D shall include but not limited to:
 - a. Panelboards, electrical cabinets, and enclosures.
 - b. Access doors and panels for concealed electrical items.
 - c. Electrical switchboards.
 - d. Transformers.
 - e. Automatic transfer switches.
 - f. Emergency system boxes and enclosures.
 - g. Motor-control centers.
 - h. Disconnect switches.
 - i. Enclosed circuit breakers.
 - j. Motor starters.
 - k. Push-button stations.
 - l. Power transfer equipment.
 - m. Contactors.
 - n. Remote-controlled switches, dimmer modules, and control devices.
 - o. Battery inverter units.
 - p. Battery racks.
 - q. Power-generating units.
 - r. Master clock and program equipment.
 - s. Intercommunication and call system master and staff stations.
 - t. Television/audio components, racks, and controls.
 - u. Fire-alarm control panel and annunciators.
 - v. Security and intrusion-detection control stations, control panels, terminal cabinets, and racks.
 - w. Monitoring and control equipment.
 - x. Uninterruptible power supply equipment.
 - y. Terminals, racks, and patch panels for voice and data communication and for signal and control functions.

3.2 INSTALLATION

- A. Verify identity of each item before installing identification products.
- B. Location: Install identification materials and devices at locations for most convenient viewing without interference with operation and maintenance of equipment.
- C. Apply identification devices to surfaces that require finish after completing finish work.
- D. Self-Adhesive Identification Products: Clean surfaces before application, using materials and methods recommended by manufacturer of identification device.
- E. Attach nonadhesive signs and plastic labels with screws and auxiliary hardware appropriate to the location and substrate.
- F. System Identification Color Banding for Raceways and Cables: Each color band shall completely encircle cable or conduit. Place adjacent bands of two-color markings in contact, side by side. Locate bands at changes in direction, at penetrations of walls and floors, at 50-foot (15-m) maximum intervals in straight runs, and at 25-foot (7.6-m) maximum intervals in congested areas. MI-cable shall be banded 6-foot maximum intervals per Maine Medical standards.
- G. Color-Coding for Phase and neutral Identification, 600 V and Less: Use the colors listed below for ungrounded service, feeder, and branch-circuit conductors.
 - 1. Color shall be factory applied or, for sizes larger than No. 10 AWG if authorities having jurisdiction permit, field applied.
 - 2. Colors for 208/120-V Circuits:
 - a. Phase A: Black.
 - b. Phase B: Red.
 - c. Phase C: Blue.
 - d. Neutral: White
 - 3. Colors for 480/277-V Circuits:
 - a. Phase A: Brown.
 - b. Phase B: Orange.
 - c. Phase C: Yellow.
 - d. Neutral: Gray
 - 4. Field-Applied, Color-Coding Conductor Tape: Apply in half-lapped turns for a minimum distance of 6 inches (150 mm) from terminal points and in boxes where splices or taps are made. Apply last two turns of tape with no tension to prevent possible unwinding. Locate bands to avoid obscuring factory cable markings.
- H. Underground-Line Warning Tape: During backfilling of trenches install continuous underground-line warning tape directly above line at 6 to 8 inches (150 to 200 mm) below finished grade. Use multiple tapes where width of multiple lines installed in a common trench or concrete envelope exceeds 16 inches (400 mm) overall.
- I. Painted Identification: Prepare surface and apply paint according to Division 09 painting Sections.

END OF SECTION

This page is intentionally left blank.

SECTION 26 05 73

OVERCURRENT PROTECTIVE DEVICE COORDINATION STUDY

PART 1 - GENERAL

1.1 RELATED DOCUMENTS

- A. Drawings and general provisions of the Contract, including General and Supplementary Conditions and Division 01 Specification Sections, apply to this Section.
- B. Refer to riser diagrams included in drawing set.
- C. Section 01 81 13 "Sustainable Design Requirements – LEED v4 for Building Design & Construction – New Construction" for sustainable design requirements and detailed sustainable design submittal requirements.
- D. Section 01 74 19 "Construction and Demolition Waste Management and Disposal" for disposal of construction, demolition and packaging waste disposal requirements.

1.2 SUMMARY

- A. This Section includes computer-based, fault-current and overcurrent protective device coordination studies. Protective devices shall be set based on results of the protective device coordination study.
 - 1. Series-rated devices are not permitted. All devices shall be fully rated to meet the available fault and equipment at the point of installation.
- B. The contractor shall provide an engineering analysis and coordination study for the entire electrical distribution system. The analysis shall include a short-circuit analysis with protective device evaluation, ground fault coordination evaluation and a protective device coordination study.
- C. The analysis shall begin at the point of primary service for the facility and continue down through the system, to all downstream distribution and branch panelboards, and significant motor locations.
- D. Sustainable Building Requirements:
 - 1. The Owner requires the Contractor to implement practices and procedures to meet the project's environmental performance goals, which include achieving LEED version 4 Certified level Certification. Specific project goals that may impact this area of work include: use of recycled-content materials; use of locally-manufactured materials; use of low-emitting materials; construction waste recycling; and the implementation of a construction indoor air quality management plan. The Contractor shall ensure that the requirements related to these goals, as defined in the Articles below, are implemented to the fullest extent. Substitutions, or other changes to the work proposed by the Contractor or their Subcontractors, shall not be allowed if such changes compromise the aforementioned environmental goals and LEED certification.

1.3 SUBMITTALS

- A. Product Data: For computer software program to be used for studies.
- B. Product Certificates: For coordination-study and fault-current-study computer software programs, certifying compliance with IEEE 399.
- C. Qualification Data: For coordination-study specialist.
- D. Other Action Submittals: The following submittals shall be made after the approval process for system protective devices has been completed. Submittals may be in digital form (with one printed copy)
 - 1. Coordination-study input data, including completed computer program input data sheets.
 - 2. Study and Equipment Evaluation Reports.
 - 3. Coordination-Study Report.
- E. Shop drawings for equipment will not be reviewed until the coordination study has been submitted and approved. Submit a preliminary study with estimated feeder lengths with first distribution submittal that verifies submitted overcurrent protective devices provide "clean" coordination. Submit a final study with feeder lengths as installed, that verifies all data in preliminary report. Adjust all overcurrent protective devices types and/or settings as required after final approval.

1.4 QUALITY ASSURANCE

- A. Studies shall use computer programs that are distributed nationally and are in wide use. Software algorithms shall comply with requirements of standards and guides specified in this Section. Manual calculations are not acceptable.
- B. Coordination-Study Specialist Qualifications: A firm experienced in the application of computer software used for studies, having performed successful studies of similar magnitude on electrical distribution systems using similar devices. Firm must have a minimum of 5 years of experience of successful study completion.
 - 1. Professional engineer, licensed in the State of Maine, shall be responsible for the study. All elements of the study shall be performed under the direct supervision and control of engineer. Study shall be signed and sealed by professional engineer. Engineer shall have a minimum of 8 years' experience in the analysis, evaluation and coordination of electrical distribution systems.
- C. Comply with IEEE 242 for short-circuit currents and coordination time intervals.
- D. Comply with IEEE 399 for general study procedures.
- E. Level of system coordination shall reflect the intention of system planning per IEEE std-192.
- F. Contractor shall submit electrical distribution equipment based on the system design and listed acceptable manufacturers. The contractor shall provide with the submittal, a coordination study based on the equipment submitted. The contractor shall be required to submit equipment equal in characteristics to the basis of design. This is to say the selectivity of the overcurrent devices shall be as clean in coordination as the basis of design devices.
- G. Should the contractor submit a study, including related equipment submittal, that does not give clean coordination; the contractor shall be obligated to change

components to allow clean coordination and selectivity, prior to getting approval for releasing equipment for manufacture at no additional cost to the project.

- H. The study shall be prepared in accordance with the latest edition of NETA Std. ATS, NFPA 70, the "National Electrical Code", ANSI C2 "National Electrical Safety Code", and ANSI/IEEE Guidelines, as well as manufacturer's recommendations.

PART 2 - PRODUCTS

2.1 COMPUTER SOFTWARE DEVELOPERS

- A. Available Computer Software Developers: Subject to compliance with requirements, companies offering computer software programs that may be used in the Work include, but are not limited to, the following:
 - 1. SKM Systems Analysis, Inc.

2.2 COMPUTER SOFTWARE PROGRAM REQUIREMENTS

- A. Comply with IEEE 399.
- B. Analytical features of fault-current-study computer software program shall include "mandatory," "very desirable," and "desirable" features as listed in IEEE 399.
- C. Computer software program shall be capable of plotting and diagramming time-current-characteristic curves as part of its output. Computer software program shall report device settings and ratings of all overcurrent protective devices and shall demonstrate selective coordination by computer-generated, time-current coordination plots.
 - 1. Optional Features:
 - a. Arcing faults.
 - b. Simultaneous faults.
 - c. Explicit negative sequence.
 - d. Mutual coupling in zero sequence.
- D. Study preparer shall update the MMC Master Coordination and Arc Flash Study with the equipment installed as part of this project. Existing study to be updated shall be obtained from MMC Engineering and Facilities.

PART 3 - EXECUTION

3.1 EXAMINATION

- A. Examine Project overcurrent protective device submittals for compliance with electrical distribution system coordination requirements and other conditions affecting performance. Devices to be coordinated are indicated on Drawings.
 - 1. Proceed with coordination study only after relevant equipment submittals have been assembled and approved. Overcurrent protective devices that have not been submitted and approved prior to coordination study may not be used in study.

3.2 POWER SYSTEM DATA

- A. Gather and tabulate the following input data to support coordination study:
1. Product Data for overcurrent protective devices specified in other Division 26 Sections and involved in overcurrent protective device coordination studies. Use equipment designation tags that are consistent with electrical distribution system diagrams, overcurrent protective device submittals, input and output data, and recommended device settings.
 2. Impedance of utility service entrance. Obtain the available fault current from the serving utility company.
 3. Electrical Distribution System Diagram: In hard-copy and electronic-copy formats, showing the following:
 - a. Circuit-breaker and fuse-current ratings along with types.
 - b. Relays and associated power and current transformer ratings and ratios.
 - c. Transformer kilovolt amperes, primary and secondary voltages, connection type, impedance, and X/R ratios.
 - d. Generator kilovolt amperes, size, voltage, and source impedance.
 - e. Cables: Indicate conduit material, sizes of conductors, conductor material, insulation, and length.
 - f. Busway ampacity and impedance.
 - g. Motor horsepower and code letter designation according to NEMA MG 1.
 4. Data sheets to supplement electrical distribution system diagram, cross-referenced with tag numbers on diagram, showing the following:
 - a. Special load considerations, including starting inrush currents and frequent starting and stopping.
 - b. Transformer characteristics, including primary protective device, magnetic inrush current, and overload capability.
 - c. Motor full-load current, locked rotor current, service factor, starting time, type of start, and thermal-damage curve.
 - d. Generator thermal-damage curve.
 - e. Ratings, types, and settings of utility company's overcurrent protective devices.
 - f. Special overcurrent protective device settings or types stipulated by utility company.
 - g. Time-current-characteristic curves of devices indicated to be coordinated.
 - h. Manufacturer, frame size, interrupting rating in amperes rms symmetrical, ampere or current sensor rating, long-time adjustment range, short-time adjustment range, and instantaneous adjustment range for circuit breakers.
 - i. Manufacturer and type, ampere-tap adjustment range, time-delay adjustment range, instantaneous attachment adjustment range, and current transformer ratio for overcurrent relays.
 - j. Panelboards, switchboards, motor-control center ampacity, and interrupting rating in amperes rms symmetrical.

3.3 FAULT-CURRENT STUDY

- A. Calculate the maximum available short-circuit current in amperes rms symmetrical at circuit-breaker positions of the electrical power distribution system to determine the required settings/sizes of the protective devices to maximize selectivity. The calculation shall be for a current immediately after initiation and for a three-phase bolted short circuit at each of the following:

1. Distribution panelboards.
2. Branch circuit panelboards.
- B. Study electrical distribution system from normal and alternate power sources throughout electrical distribution system for the Project. Include studies of system-switching configurations and alternate operations that could result in maximum fault conditions.
- C. Calculate momentary and interrupting duties on the basis of maximum available fault current. Motor contribution shall be incorporated in determining fault levels. Assume 50 percent of motor loads being served by VFD's are in by-pass mode.
- D. Calculations to verify interrupting ratings of overcurrent protective devices shall comply with IEEE 141, IEEE 241 and IEEE 242.
 1. Transformers:
 - a. ANSI C57.12.10.
 - b. ANSI C57.12.22.
 - c. ANSI C57.12.40.
 - d. IEEE C57.12.00.
 - e. IEEE C57.96.
 2. Low-Voltage Circuit Breakers: IEEE 1015 and IEEE C37.20.1.
 3. Low-Voltage Fuses: IEEE C37.46.
- E. Study Report:
 1. Show calculated X/R ratios and equipment interrupting rating (1/2-cycle) fault currents on electrical distribution system diagram.
 2. Show interrupting (5-cycle) and time-delayed currents (6 cycles and above) on medium- and high-voltage breakers as needed to set relays and assess the sensitivity of overcurrent relays.
- F. Equipment Evaluation Report:
 1. For 600-V overcurrent protective devices, ensure that interrupting ratings are equal to or higher than calculated 1/2-cycle symmetrical fault current.
 2. For devices and equipment rated for asymmetrical fault current, apply multiplication factors listed in the standards to 1/2-cycle symmetrical fault current.
 3. Verify adequacy of phase conductors at maximum three-phase bolted fault currents; verify adequacy of equipment grounding conductors and grounding electrode conductors at maximum ground-fault currents. Ensure that short-circuit withstand ratings are equal to or higher than calculated 1/2-cycle symmetrical fault current.

3.4 COORDINATION STUDY

- A. Perform coordination study using approved computer software program. Prepare a written report using results of fault-current study. Comply with IEEE 399.
 1. Calculate the maximum and minimum 1/2-cycle short-circuit currents.
 2. Calculate the maximum and minimum interrupting duty (5 cycles to 2 seconds) short-circuit currents.
 3. Calculate the maximum and minimum ground-fault currents.
- B. Comply with IEEE 141 recommendations for fault currents and time intervals.
- C. Transformer Primary Overcurrent Protective Devices:
 1. Device shall not operate in response to the following:
 - a. Inrush current when first energized.

- b. Self-cooled, full-load current or forced-air-cooled, full-load current, whichever is specified for that transformer.
 - c. Permissible transformer overloads according to IEEE C57.96 if required by unusual loading or emergency conditions.
 2. Device settings shall protect transformers according to IEEE C57.12.00, for fault currents.
 - D. Conductor Protection: Protect cables against damage from fault currents according to ICEA P-32-382, ICEA P-45-482, and conductor melting curves in IEEE 242. Demonstrate that equipment withstands the maximum short-circuit current for a time equivalent to the tripping time of the primary relay protection or total clearing time of the fuse. To determine temperatures that damage insulation, use curves from cable manufacturers or from listed standards indicating conductor size and short-circuit current.
 - E. Coordination-Study Report: Prepare a written report indicating the following results of coordination study:
 1. Tabular Format of Settings Selected for Overcurrent Protective Devices:
 - a. Device tag.
 - b. Relay-current transformer ratios; and tap, time-dial, and instantaneous-pickup values.
 - c. Circuit-breaker sensor rating; and long-time, short-time, and instantaneous settings.
 - d. Fuse-current rating and type.
 - e. Ground-fault relay-pickup and time-delay settings.
 2. Coordination Curves: Prepared to determine settings of overcurrent protective devices to achieve maximum selective coordination. Level of selective coordination to be approved by engineer (AKF). Graphically illustrate that adequate time separation exists between devices installed in series, including power utility company's main device. Prepare separate sets of curves for the switching schemes and for emergency periods where the power source is local generation. Show the following information:
 - a. Device tag.
 - b. Voltage and current ratio for curves.
 - c. Three-phase and single-phase damage points for each transformer.
 - d. No damage, melting, and clearing curves for fuses.
 - e. Cable damage curves.
 - f. Transformer inrush points.
 - g. Maximum fault-current cutoff point.
 - h. Single-line for the portion of the system illustrated in the TCC.
 - F. Completed data sheets for setting of overcurrent protective devices.
 - G. A narrative analysis shall accompany each coordination curve sheet and describe the coordination and protection in explicit detail. All curve sheets shall be multi-color for improved clarity. Areas lacking complete coordination shall be highlighted and reasons provided for allowing condition to remain or provide solution to resolve situation.
- 3.5 GROUND FAULT COORDINATION EVALUATION
 - A. The report shall include a ground fault coordination evaluation for operation of the service and feeder disconnecting means such that the feeder device, but not the service device, shall open on ground faults on the load side of the feeder device. A

six-cycle minimum separation between the service and feeder tripping bands shall be provided. Operating time of the disconnecting devices shall be considered in selecting the time spread between these two bands to achieve 100 percent selectivity.

- B. Provide a schedule of all settings for ground fault protection devices to include relay pick-up and time delay settings.
- C. The ground fault protection system shall be performance tested when first installed on site. The test shall be conducted in accordance with the instructions that shall be provided with the equipment. A written record of this test shall be made and submitted to the Architect/Engineer. A copy shall be available to the Authority having Jurisdiction.

3.6 ARC-FLASH EVALUTION

- A. The final report shall include an arc-flash study for all new equipment. Arc flash study shall be performed per NFPA 70E - "calculated method" requirements. Labels of calculated values shall be submitted to the electrical contractor.
- B. Electrical contractor shall label all new equipment with calculated arc-flash labels from study.

3.7 FIELD SETTINGS

- A. The contractor shall engage the manufacturer's service group or alternately a qualified independent testing firm to perform field adjustments of the protective devices as required for placing the equipment in final operating condition. The settings shall be in accordance with the approved short circuit study and protective device evaluation/coordination study.
- B. Necessary field settings of devices and adjustments and minor modifications to equipment to accomplish conformance with the approved short-circuit and protective device coordination study, shall be carried out by manufacturer's service group.

END OF SECTION

This page is intentionally left blank.

SECTION 26 09 23

LIGHTING CONTROL DEVICES

PART 1 - GENERAL

1.1 RELATED DOCUMENTS

- A. Drawings and general provisions of the Contract, including General and Supplementary Conditions and Division 01 Specification Sections, apply to this Section.
- B. Section 01 81 13 "Sustainable Design Requirements – LEED v4 for Building Design & Construction – New Construction" for sustainable design requirements and detailed sustainable design submittal requirements.
- C. Section 01 74 19 "Construction and Demolition Waste Management and Disposal" for disposal of construction, demolition and packaging waste disposal requirements.

1.2 SUMMARY

- A. This Section includes the following lighting control devices:
 - 1. Time switches.
 - 2. Photoelectric switches.
 - 3. Indoor occupancy sensors.
 - 4. Outdoor motion sensors.
 - 5. Lighting contactors.
 - 6. Emergency shunt relays.
- B. Related Sections include the following:
 - 1. Division 26 Section "Network Lighting Controls" for low-voltage, manual and programmable lighting control systems.
 - 2. Division 26 Section "Wiring Devices" for wall-box dimmers, wall-switch occupancy sensors, and manual light switches.
- C. Sustainable Building Requirements:
 - 1. The Owner requires the Contractor to implement practices and procedures to meet the project's environmental performance goals, which include achieving LEED version 4 Certified level Certification. Specific project goals that may impact this area of work include: use of recycled-content materials; use of locally-manufactured materials; use of low-emitting materials; construction waste recycling; and the implementation of a construction indoor air quality management plan. The Contractor shall ensure that the requirements related to these goals, as defined in the Articles below, are implemented to the fullest extent. Substitutions, or other changes to the work proposed by the Contractor or their Subcontractors, shall not be allowed if such changes compromise the aforementioned environmental goals and LEED certification.

1.3 DEFINITIONS

- A. LED: Light-emitting diode.
- B. PIR: Passive infrared.

1.4 SUBMITTALS

- A. Product Data: For each type of product indicated.
- B. Shop Drawings: Show installation details for occupancy and light-level sensors.
 - 1. Interconnection diagrams showing field-installed wiring.
- C. Field quality-control test reports.
- D. Operation and Maintenance Data: For each type of product to include in emergency, operation, and maintenance manuals.

1.5 QUALITY ASSURANCE

- A. Electrical Components, Devices, and Accessories: Listed and labeled as defined in NFPA 70, Article 100, by a testing agency acceptable to authorities having jurisdiction, and marked for intended use.

1.6 COORDINATION

- A. Coordinate layout and installation of ceiling-mounted devices with other construction that penetrates ceilings or is supported by them, including light fixtures, HVAC equipment, smoke detectors, fire-suppression system, and partition assemblies.

PART 2 - PRODUCTS

2.1 INDOOR OCCUPANCY SENSORS

- A. Manufacturers: Subject to compliance with requirements, provide products by one of the following:
 - 1. Hubbell Lighting.
 - 2. Leviton Mfg. Company Inc.
 - 3. Lithonia Lighting; Acuity Lighting Group, Inc.
 - 4. Sensor Switch, Inc.
 - 5. Watt Stopper (The).
- B. General Description: Wall- or ceiling-mounting, solid-state units with a separate relay unit.
 - 1. Operation: Unless otherwise indicated, turn lights on when covered area is occupied and off when unoccupied; with a time delay for turning lights off, adjustable over a minimum range of 1 to 15 minutes.
 - 2. Sensor Output: Contacts rated to operate the connected relay, complying with UL 773A. Sensor shall be powered from the relay unit.
 - 3. Relay Unit: Dry contacts rated for 20-A ballast load at 120- and 277-V ac, for 13-A tungsten at 120-V ac, and for 1 hp at 120-V ac. Power supply to sensor shall be 24-V dc, 150-mA, Class 2 power source as defined by NFPA 70.
 - 4. Mounting:

- a. Sensor: Suitable for mounting in any position on a standard outlet box.
 - b. Relay: Externally mounted through a 1/2-inch (13-mm) knockout in a standard electrical enclosure.
 - c. Time-Delay and Sensitivity Adjustments: Recessed and concealed behind hinged door.
5. Indicator: LED, to show when motion is being detected during testing and normal operation of the sensor.
 6. Bypass Switch: Override the on function in case of sensor failure.
 7. Automatic Light-Level Sensor: Adjustable from 2 to 200 fc (21.5 to 2152 lx); keep lighting off when selected lighting level is present.
- C. Dual-Technology Type: Ceiling mounting; detect occupancy by using a combination of PIR and ultrasonic detection methods in area of coverage. Particular technology or combination of technologies that controls on-off functions shall be selectable in the field by operating controls on unit.
1. Sensitivity Adjustment: Separate for each sensing technology.
 2. Detector Sensitivity: Detect occurrences of 6-inch- (150-mm-) minimum movement of any portion of a human body that presents a target of not less than 36 sq. in. (232 sq. cm), and detect a person of average size and weight moving not less than 12 inches (305 mm) in either a horizontal or a vertical manner at an approximate speed of 12 inches/s (305 mm/s).
 3. Detection Coverage (Standard Room): Detect occupancy anywhere within a circular area of 1000 sq. ft. (93 sq. m) when mounted on a 96-inch- (2440-mm-) high ceiling.

2.2 CONDUCTORS AND CABLES

- A. Power Wiring to Supply Side of Remote-Control Power Sources: Not smaller than No. 12 AWG. Comply with requirements in Division 26 Section "Low-Voltage Electrical Power Conductors and Cables."
- B. Classes 2 and 3 Control Cable: Multiconductor cable with stranded-copper conductors not smaller than No. 18 AWG. Comply with requirements in Division 26 Section "Low-Voltage Electrical Power Conductors and Cables."
- C. Class 1 Control Cable: Multiconductor cable with stranded-copper conductors not smaller than No. 16 AWG. Comply with requirements in Division 26 Section "Low-Voltage Electrical Power Conductors and Cables."

PART 3 - EXECUTION

3.1 SENSOR INSTALLATION

- A. Install and aim sensors in locations to achieve not less than 90 percent coverage of areas indicated. Do not exceed coverage limits specified in manufacturer's written instructions.

3.2 CONTACTOR INSTALLATION

- A. Mount electrically held lighting contactors with elastomeric isolator pads, to eliminate structure-borne vibration, unless contactors are installed in an enclosure with factory-installed vibration isolators.

3.3 WIRING INSTALLATION

- A. Wiring Method: Comply with Division 26 Section "Low-Voltage Electrical Power Conductors and Cables." Minimum conduit size shall be 1/2 inch (13 mm).
- B. Wiring within Enclosures: Comply with NECA 1. Separate power-limited and nonpower-limited conductors according to conductor manufacturer's written instructions.
- C. Size conductors according to lighting control device manufacturer's written instructions, unless otherwise indicated.
- D. Splices, Taps, and Terminations: Make connections only on numbered terminal strips in junction, pull, and outlet boxes; terminal cabinets; and equipment enclosures.

3.4 IDENTIFICATION

- A. Identify components and power and control wiring according to Division 26 Section "Identification for Electrical Systems."
 - 1. Identify controlled circuits in lighting contactors.
 - 2. Identify circuits or luminaries controlled by photoelectric and occupancy sensors at each sensor.
- B. Label time switches and contactors with a unique designation.

3.5 FIELD QUALITY CONTROL

- A. Perform the following field tests and inspections and prepare test reports:
 - 1. After installing time switches and sensors, and after electrical circuitry has been energized, adjust and test for compliance with requirements.
 - 2. Operational Test: Verify operation of each lighting control device, and adjust time delays.
- B. Lighting control devices that fail tests and inspections are defective work.

3.6 ADJUSTING

- A. Occupancy Adjustments: When requested within 12 months of date of Substantial Completion, provide on-site assistance in adjusting sensors to suit occupied conditions. During business hours provide up to two visits to Project during other-than-normal occupancy hours for this purpose.

3.7 DEMONSTRATION

- A. Coordinate demonstration of products specified in this Section with demonstration requirements for low-voltage, programmable lighting control system specified in Division 26 Section "Network Lighting Controls."
- B. Engage a factory-authorized service representative to train Owner's maintenance personnel to adjust, operate, and maintain lighting control devices. Refer to Division 01 Section "Demonstration and Training."

END OF SECTION

SECTION 26 22 00

LOW-VOLTAGE TRANSFORMERS

PART 1 - GENERAL

1.1 RELATED DOCUMENTS

- A. Drawings and general provisions of the Contract, including General and Supplementary Conditions and Division 01 Specification Sections, apply to this Section.
- B. Section 01 81 13 "Sustainable Design Requirements – LEED v4 for Building Design & Construction – New Construction" for sustainable design requirements and detailed sustainable design submittal requirements.
- C. Section 01 74 19 "Construction and Demolition Waste Management and Disposal" for disposal of construction, demolition and packaging waste disposal requirements.

1.2 SUMMARY

- A. This Section includes the following types of dry-type transformers rated 600 V and less, with capacities up to 1000 kVA:
 - 1. Distribution transformers.
- B. Sustainable Building Requirements:
 - 1. The Owner requires the Contractor to implement practices and procedures to meet the project's environmental performance goals, which include achieving LEED version 4 Certified level Certification. Specific project goals that may impact this area of work include: use of recycled-content materials; use of locally-manufactured materials; use of low-emitting materials; construction waste recycling; and the implementation of a construction indoor air quality management plan. The Contractor shall ensure that the requirements related to these goals, as defined in the Articles below, are implemented to the fullest extent. Substitutions, or other changes to the work proposed by the Contractor or their Subcontractors, shall not be allowed if such changes compromise the aforementioned environmental goals and LEED certification.

1.3 SUBMITTALS

- A. Product Data: Include rated nameplate data, capacities, weights, dimensions, minimum clearances, installed devices and features, and performance for each type and size of transformer indicated.
- B. Shop Drawings: Detail equipment assemblies and indicate dimensions, weights, loads, required clearances, method of field assembly, components, and location and size of each field connection.
 - 1. Wiring Diagrams: Power, signal, and control wiring.

- C. **Manufacturer Seismic Qualification Certification:** Submit certification that transformers, accessories, and components will withstand seismic forces defined in Division 26 Section "Vibration and Seismic Controls for Electrical Systems." Include the following:
 - 1. **Basis for Certification:** Indicate whether withstand certification is based on actual test of assembled components or on calculation.
 - a. The term "withstand" means "the unit will remain in place without separation of any parts from the device when subjected to the seismic forces specified."
 - b. The term "withstand" means "the unit will remain in place without separation of any parts from the device when subjected to the seismic forces specified and the unit will be fully operational after the seismic event."
 - 2. **Dimensioned Outline Drawings of Equipment Unit:** Identify center of gravity and locate and describe mounting and anchorage provisions.
 - 3. **Detailed description of equipment anchorage devices** on which the certification is based and their installation requirements.
- D. **Qualification Data:** For testing agency.
- E. **Source quality-control test reports.**
- F. **Field quality-control test reports.**
- G. **Operation and Maintenance Data:** For transformers to include in emergency, operation, and maintenance manuals.

1.4 QUALITY ASSURANCE

- A. **Testing Agency Qualifications:** An independent agency, with the experience and capability to conduct the testing indicated, that is a member company of the InterNational Electrical Testing Association or is a nationally recognized testing laboratory (NRTL) as defined by OSHA in 29 CFR 1910.7, and that is acceptable to authorities having jurisdiction.
 - 1. **Testing Agency's Field Supervisor:** Person currently certified by the InterNational Electrical Testing Association or the National Institute for Certification in Engineering Technologies to supervise on-site testing specified in Part 3.
- B. **Testing Agency Qualifications:** An independent agency, with the experience and capability to conduct the testing indicated, that is a nationally recognized testing laboratory (NRTL) as defined by OSHA in 29 CFR 1910.7.
- C. **Source Limitations:** Obtain each transformer type through one source from a single manufacturer.
- D. **Electrical Components, Devices, and Accessories:** Listed and labeled as defined in NFPA 70, Article 100, by a testing agency acceptable to authorities having jurisdiction, and marked for intended use.
- E. **Comply with IEEE C57.12.91, "Test Code for Dry-Type Distribution and Power Transformers."**

1.5 DELIVERY, STORAGE, AND HANDLING

- A. Temporary Heating: Apply temporary heat according to manufacturer's written instructions within the enclosure of each ventilated-type unit, throughout periods during which equipment is not energized and when transformer is not in a space that is continuously under normal control of temperature and humidity.

1.6 COORDINATION

- A. Coordinate size and location of concrete bases with actual transformer provided. Cast anchor-bolt inserts into bases. Concrete, reinforcement, and formwork requirements are specified in Division 03.
- B. Coordinate installation of wall-mounting and structure-hanging supports with actual transformer provided.

PART 2 - PRODUCTS

2.1 MANUFACTURERS

- A. Available Manufacturers: Subject to compliance with requirements, manufacturers offering products that may be incorporated into the Work include, but are not limited to, the following:
 - 1. Eaton Electrical Inc.; Cutler-Hammer Products.
 - 2. General Electric Company.
 - 3. Siemens Energy & Automation, Inc.
 - 4. Square D; Schneider Electric.

2.2 GENERAL TRANSFORMER REQUIREMENTS

- A. Description: Factory-assembled and -tested, air-cooled units for 60-Hz service.
- B. Cores: Grain-oriented, non-aging silicon steel.
- C. Coils: Continuous windings without splices except for taps.
 - 1. Internal Coil Connections: Brazed or pressure type.

2.3 DISTRIBUTION TRANSFORMERS

- A. All bus and windings shall be copper.
- B. Comply with NEMA ST 20, and list and label as complying with UL 1561.
- C. Provide transformers that are constructed to withstand seismic forces specified in Division 26 Section "Vibration and Seismic Controls for Electrical Systems."
- D. Cores: One leg per phase.
- E. Enclosure: Ventilated, NEMA 250, Type 2.
 - 1. Core and coil shall be encapsulated within resin compound, sealing out moisture and air for 15 kVA units and smaller. Ventilated design for units over 15 kVA.
- F. Transformer Enclosure Finish: Comply with NEMA 250.
 - 1. Finish Color: ANSI 61 gray.

- G. Taps for Transformers Smaller Than 3 kVA: None.
- H. Taps for Transformers 7.5 to 24 kVA: One 5 percent tap above and one 5 percent tap below normal full capacity.
- I. Taps for Transformers 25 kVA and Larger: Two 2.5 percent taps above and two 2.5 percent taps below normal full capacity.
- J. Insulation Class: 220 deg C, UL-component-recognized insulation system with a maximum of 150 deg C rise above 40 deg C ambient temperature.
- K. Energy Efficiency for Transformers Rated 15 kVA and Larger:
 - 1. Complying with DOE 2016 Efficiency Standards.
- L. K-Factor Rating: Transformers indicated to be K-factor rated shall comply with UL 1561 requirements for nonsinusoidal load current-handling capability to the degree defined by designated K-factor. All bus and windings shall be copper.
 - 1. Unit shall not overheat when carrying full-load current with harmonic distortion corresponding to designated K-factor.
 - 2. Indicate value of K-factor on transformer nameplate.
- M. Electrostatic Shielding: Where indicated each winding shall have an independent, single, full-width copper electrostatic shield arranged to minimize interwinding capacitance.
 - 1. Arrange coil leads and terminal strips to minimize capacitive coupling between input and output terminals.
 - 2. Include special terminal for grounding the shield.
 - 3. Shield Effectiveness:
 - a. Capacitance between Primary and Secondary Windings: Not to exceed 33 picofarads over a frequency range of 20 Hz to 1 MHz.
 - b. Common-Mode Noise Attenuation: Minimum of minus 120 dBA at 0.5 to 1.5 kHz; minimum of minus 65 dBA at 1.5 to 100 kHz.
 - c. Normal-Mode Noise Attenuation: Minimum of minus 52 dBA at 1.5 to 10 kHz.
- N. Wall Brackets: Manufacturer's standard brackets.
- O. Fungus Proofing: Permanent fungicidal treatment for coil and core.
- P. Low-Sound-Level Requirements: Minimum of 3 dBA less than NEMA ST 20 standard sound levels when factory tested according to IEEE C57.12.91.
- Q. Low-Sound-Level Requirements: Maximum sound levels, when factory tested according to IEEE C57.12.91, as follows:
 - 1. 9 kVA and Less: 40dBA
 - 2. 30 to 50 kVA: 45dBA
 - 3. 51 to 150 kVA: 50dBA
 - 4. 151 to 300 kVA: 55dBA
 - 5. 301 to 500 kVA: 60dBA
 - 6. 501 to 750 kVA: 62dBA
 - 7. 751 to 1000 kVA: 64dBA

2.4 IDENTIFICATION DEVICES

- A. Nameplates: Engraved, laminated-plastic or metal nameplate for each distribution transformer, mounted with corrosion-resistant screws. Nameplates and label products are specified in Division 26 Section "Identification for Electrical Systems."

2.5 SOURCE QUALITY CONTROL

- A. Test and inspect transformers according to IEEE C57.12.91.
- B. Factory Sound-Level Tests: Conduct sound-level tests on equipment for this Project.

PART 3 - EXECUTION

3.1 EXAMINATION

- A. Examine conditions for compliance with enclosure- and ambient-temperature requirements for each transformer.
- B. Verify that field measurements are as needed to maintain working clearances required by NFPA 70 and manufacturer's written instructions.
- C. Examine walls, floors, roofs, and concrete bases for suitable mounting conditions where transformers will be installed.
- D. Verify that ground connections are in place and requirements in Division 26 Section "Grounding and Bonding for Electrical Systems" have been met. Maximum ground resistance shall be 5 ohms at location of transformer.
- E. Proceed with installation only after unsatisfactory conditions have been corrected.

3.2 INSTALLATION

- A. Install wall-mounting transformers level and plumb with wall brackets fabricated by transformer manufacturer.
 - 1. Brace wall-mounting transformers as specified in Division 26 Section "Vibration and Seismic Controls for Electrical Systems."
- B. Construct concrete bases and anchor floor-mounting transformers according to manufacturer's written instructions, seismic codes applicable to Project, and requirements in Division 26 Section "Vibration and Seismic Controls for Electrical Systems."
- C. Provide neoprene mounts equal to Mason Industries ND to achieve .25 inch static deflection under load.

3.3 CONNECTIONS

- A. Ground equipment according to Division 26 Section "Grounding and Bonding for Electrical Systems."
- B. Connect wiring according to Division 26 Section "Low-Voltage Electrical Power Conductors and Cables."

3.4 FIELD QUALITY CONTROL

- A. Manufacturer's Field Service: Engage a factory-authorized service representative to inspect, test, and adjust components, assemblies, and equipment installations, including connections. Report results in writing.

1. Perform each visual and mechanical inspection and electrical test stated in NETA Acceptance Testing Specification. Certify compliance with test parameters.
- B. Remove and replace units that do not pass tests or inspections and retest as specified above.
- C. Test Labeling: On completion of satisfactory testing of each unit, attach a dated and signed "Satisfactory Test" label to tested component.

3.5 ADJUSTING

- A. Record transformer secondary voltage at each unit for at least 48 hours of typical occupancy period. Adjust transformer taps to provide optimum voltage conditions at secondary terminals. Optimum is defined as not exceeding nameplate voltage plus 10 percent and not being lower than nameplate voltage minus 3 percent at maximum load conditions. Submit recording and tap settings as test results.
- B. Connect buck-boost transformers to provide nameplate voltage of equipment being served, plus or minus 5 percent, at secondary terminals.
- C. Output Settings Report: Prepare a written report recording output voltages and tap settings.

3.6 CLEANING

- A. Vacuum dirt and debris; do not use compressed air to assist in cleaning.

END OF SECTION

SECTION 26 24 16

PANELBOARDS

PART 1 - GENERAL

1.1 RELATED DOCUMENTS

- A. Drawings and general provisions of the Contract, including General and Supplementary Conditions and Division 01 Specification Sections, apply to this Section.
- B. Section 01 81 13 "Sustainable Design Requirements – LEED v4 for Building Design & Construction – New Construction" for sustainable design requirements and detailed sustainable design submittal requirements.
- C. Section 01 74 19 "Construction and Demolition Waste Management and Disposal" for disposal of construction, demolition and packaging waste disposal requirements.

1.2 SUMMARY

- A. Section Includes:
 - 1. Distribution panelboards.
 - 2. Lighting and appliance branch-circuit panelboards.
- B. Sustainable Building Requirements:
 - 1. The Owner requires the Contractor to implement practices and procedures to meet the project's environmental performance goals, which include achieving LEED version 4 **Certified** level Certification. Specific project goals that may impact this area of work include: use of recycled-content materials; use of locally-manufactured materials; use of low-emitting materials; construction waste recycling; and the implementation of a construction indoor air quality management plan. The Contractor shall ensure that the requirements related to these goals, as defined in the Articles below, are implemented to the fullest extent. Substitutions, or other changes to the work proposed by the Contractor or their Subcontractors, shall not be allowed if such changes compromise the aforementioned environmental goals and LEED certification.

1.3 DEFINITIONS

- A. TVSS: Transient voltage surge suppressor.
- B. SPD: Surge Protective Device

1.4 PERFORMANCE REQUIREMENTS

- A. Seismic Performance: Panelboards shall withstand the effects of earthquake motions determined according to SEI/ASCE 7 and as listed in seismic section of this specification.

1. The term "withstand" means "the unit will remain in place without separation of any parts from the device when subjected to the seismic forces specified and the unit will be fully operational after the seismic event."

1.5 SUBMITTALS

- A. Product Data: For each type of panelboard, switching and overcurrent protective device, transient voltage suppression device, accessory, and component indicated. Include dimensions and manufacturers' technical data on features, performance, electrical characteristics, ratings, and finishes.
- B. Submittal shall include "Overcurrent Protective Coordination Study" as specified elsewhere in Division 26 Section which confirms all overcurrent protective devices submitted are in compliance with those requirements.
- C. Shop Drawings: For each panelboard and related equipment.
 1. Include dimensioned plans, elevations, sections, and details. Show tabulations of installed devices, equipment features, and ratings.
 2. Detail enclosure types and details for types other than NEMA 250, Type 1.
 3. Detail bus configuration, current, and voltage ratings.
 4. Short-circuit current rating of panelboards and overcurrent protective devices.
 5. Detail features, characteristics, ratings, and factory settings of individual overcurrent protective devices and auxiliary components.
 6. Include wiring diagrams for power, signal, and control wiring.
- D. Qualification Data: For qualified testing agency.
- E. Seismic Qualification Certificates: Submit certification that panelboards, overcurrent protective devices, accessories, and components will withstand seismic forces defined in Division 26 Section "Vibration and Seismic Controls for Electrical Systems." Include the following:
 1. Basis for Certification: Indicate whether withstand certification is based on actual test of assembled components or on calculation.
 2. Dimensioned Outline Drawings of Equipment Unit: Identify center of gravity and locate and describe mounting and anchorage provisions.
 3. Detailed description of equipment anchorage devices on which the certification is based and their installation requirements.
- F. Field Quality-Control Reports:
 1. Test procedures used.
 2. Test results that comply with requirements.
 3. Results of failed tests and corrective action taken to achieve test results that comply with requirements.
- G. Panelboard Schedules: For installation in panelboards. Submit final versions after load balancing.
- H. Operation and Maintenance Data: For panelboards and components to include in emergency, operation, and maintenance manuals. In addition to items specified in Division 01 Section "Operation and Maintenance Data," include the following:
 1. Manufacturer's written instructions for testing and adjusting overcurrent protective devices.
 2. Time-current curves, including selectable ranges for each type of overcurrent protective device that allows adjustments.

1.6 QUALITY ASSURANCE

- A. Testing Agency Qualifications: Member company of NETA or equivalent testing agency by manufacturer of distribution equipment being provided.
 - 1. Testing Agency's Field Supervisor: Currently certified by NETA or equivalent testing agency by manufacturer of distribution equipment being provided to supervise on-site testing
- B. Source Limitations: Obtain panelboards, overcurrent protective devices, components, and accessories from single source from single manufacturer.
- C. Product Selection for Restricted Space: Drawings indicate maximum dimensions for panelboards including clearances between panelboards and adjacent surfaces and other items. Comply with indicated maximum dimensions.
- D. Electrical Components, Devices, and Accessories: Listed and labeled as defined in NFPA 70, by a qualified testing agency, and marked for intended location and application.
- E. Comply with NEMA PB 1.
- F. Comply with NFPA 70.

1.7 DELIVERY, STORAGE, AND HANDLING

- A. Remove loose packing and flammable materials from inside panelboards; install temporary electric heating (250 W per panelboard) to prevent condensation.
- B. Handle and prepare panelboards for installation according to NEMA PB 1.

1.8 PROJECT CONDITIONS

- A. Environmental Limitations:
 - 1. Do not deliver or install panelboards until spaces are enclosed and weathertight, wet work in spaces is complete and dry, work above panelboards is complete, and temporary HVAC system is operating and maintaining ambient temperature and humidity conditions at occupancy levels during the remainder of the construction period.
 - 2. Rate equipment for continuous operation under the following conditions unless otherwise indicated:
 - a. Ambient Temperature: Not exceeding 23 deg F (minus 5 deg C) to plus 104 deg F (plus 40 deg C).
 - b. Altitude: Not exceeding 6600 feet (2000 m).
- B. Service Conditions: NEMA PB 1, usual service conditions, as follows:
 - 1. Ambient temperatures within limits specified.
 - 2. Altitude not exceeding 6600 feet (2000 m).

1.9 COORDINATION

- A. Coordinate layout and installation of panelboards and components with other construction that penetrates walls or is supported by them, including electrical and other types of equipment, raceways, piping, encumbrances to workspace clearance requirements, and adjacent surfaces. Maintain required workspace clearances and required clearances for equipment access doors and panels.

- B. Coordinate sizes and locations of concrete bases with actual equipment provided. Cast anchor-bolt inserts into bases. Concrete, reinforcement, and formwork requirements are specified in Division 03.

1.10 WARRANTY

- A. Special Warranty: Manufacturer's standard form in which manufacturer agrees to repair or replace transient voltage suppression devices that fail in materials or workmanship within specified warranty period.
 - 1. Warranty Period: two years from date of Substantial Completion.

1.11 EXTRA MATERIALS

- A. Furnish extra materials that match products installed and that are packaged with protective covering for storage and identified with labels describing contents.
 - 1. Keys: Two spares for each type of panelboard cabinet lock.
 - 2. Circuit Breakers Including GFCI and Ground Fault Equipment Protection (GFEP) Types: Three spares of each size, type and poles.

PART 2 - PRODUCTS

2.1 GENERAL REQUIREMENTS FOR PANELBOARDS

- A. Fabricate and test panelboards according to IEEE 344 to withstand seismic forces defined in Division 26 Section "Vibration and Seismic Controls for Electrical Systems."
- B. Enclosures: Flush- and surface-mounted cabinets. Coordinate with architectural drawings.
 - 1. Rated for environmental conditions at installed location.
 - a. Indoor Dry and Clean Locations: NEMA 250, Type 1.
 - b. Outdoor Locations: NEMA 250, Type 3R.
 - c. Kitchen and Wash-Down Areas: NEMA 250, Type 4X, stainless steel.
 - d. Other Wet or Damp Indoor Locations: NEMA 250, Type 4.
 - e. Indoor Locations Subject to Dust, Falling Dirt, and Dripping Noncorrosive Liquids: NEMA 250, Type 12.
 - 2. Hinged Front Cover: Entire front trim hinged to box and with standard door within hinged trim cover or provide door-in-door type construction so that the trim may be opened to access wireways without removing the trim from the panel. All trims shall have concealed mounting hardware when the door is closed.
 - 3. Finishes:
 - a. Panels and Trim: Steel, factory finished immediately after cleaning and pretreating with manufacturer's standard two-coat, baked-on finish consisting of prime coat and thermosetting topcoat.
 - b. Back Boxes: Galvanized steel.
 - 4. Directory Card: Inside panelboard door, mounted in transparent card holder.
 - 5. Electronic Panel schedules: Provide to owner/Architect with closeout documents.
- C. Incoming Mains Location: Top and bottom. Coordinate with drawings, and site conditions.

- D. Phase, Neutral, and Ground Buses:
 - 1. Material: Hard-drawn copper, 98 percent conductivity.
 - 2. Equipment Ground Bus: Adequate for feeder and branch-circuit equipment grounding conductors; bonded to box.
 - 3. Isolated Ground Bus: Adequate for branch-circuit isolated ground conductors; insulated from box.
 - 4. Extra-Capacity Neutral Bus: Neutral bus rated 200 percent of phase bus and UL listed as suitable for nonlinear loads.
- E. Conductor Connectors: Suitable for use with conductor material and sizes.
 - 1. Material: Hard-drawn copper, 98 percent conductivity.
 - 2. Main and Neutral Lugs: Mechanical type, compression for aluminum feeders.
 - 3. Ground Lugs and Bus-Configured Terminators: Mechanical type, compression for aluminum feeders
 - 4. Feed-Through Lugs: Mechanical type, suitable for use with conductor material. Locate at opposite end of bus from incoming lugs or main device.
 - 5. Subfeed (Double) Lugs: Mechanical type suitable for use with conductor material. Locate at same end of bus as incoming lugs or main device.
 - 6. Gutter-Tap Lugs: Mechanical type suitable for use with conductor material. Locate at same end of bus as incoming lugs or main device.
 - 7. Extra-Capacity Neutral Lugs: Rated 200 percent of phase lugs mounted on extra-capacity neutral bus.
- F. Future Devices: Mounting brackets, bus connections, filler plates, and necessary appurtenances required for future installation of devices.
- G. Panelboard Short-Circuit Current Rating: Fully rated to interrupt symmetrical short-circuit current of 65,000 or rating indicated on schedules.

2.2 DISTRIBUTION PANELBOARDS

- A. Manufacturers: Subject to compliance with requirements, provide products by one of the following in paragraph B:
 - 1. Eaton Electrical Inc.; Cutler-Hammer Business Unit.
 - 2. General Electric Company; GE Consumer & Industrial - Electrical Distribution.
 - 3. Siemens Energy & Automation, Inc.
 - 4. Square D; a brand of Schneider Electric.
- B. Panelboards: NEMA PB 1, power and feeder distribution type.
- C. Doors: Furnish semi-flush cylinder lock-and-catch assembly to secure hinged door over circuit breaker handles.
- D. Mains: Circuit breaker and Lugs only.
- E. Branch Overcurrent Protective Devices for circuit-breaker frame sizes 125 A and smaller: bolt-on circuit breakers.
- F. Branch Overcurrent Protective Devices for circuit breakers frame sizes larger than 125A: bolt-on circuit breakers.

2.3 LIGHTING AND APPLIANCE BRANCH-CIRCUIT PANELBOARDS

- A. Manufacturers: Subject to compliance with requirements, provide products by one of the following in paragraph B:
 - 1. Eaton Electrical Inc.; Cutler-Hammer Business Unit.

2. General Electric Company; GE Consumer & Industrial - Electrical Distribution.
 3. Square D; a brand of Schneider Electric.
- B. Panelboards: NEMA PB 1, lighting and appliance branch-circuit type.
 - C. Mains: Circuit breaker or lugs only.
 - D. Branch Overcurrent Protective Devices: Bolt-on circuit breakers, replaceable without disturbing adjacent units.
 - E. Doors: Concealed hinges; secured with flush latch with tumbler lock; keyed alike.
 - F. Column-Type Panelboards: Not Permitted.

2.4 DISCONNECTING AND OVERCURRENT PROTECTIVE DEVICES

- A. Manufacturers: Subject to compliance with requirements, provide products by one of the following in paragraph B:
 1. Eaton Electrical Inc.; Cutler-Hammer Business Unit.
 2. General Electric Company; GE Consumer & Industrial - Electrical Distribution.
 3. Siemens Energy & Automation, Inc.
 4. Square D; a brand of Schneider Electric.
- B. Molded-Case Circuit Breaker (MCCB): Comply with UL 489, with interrupting capacity to meet available fault currents of 65,000 or rating indicated on schedules.
 1. Thermal-Magnetic Circuit Breakers: Inverse time-current element for low-level overloads, and instantaneous magnetic trip element for short circuits. Adjustable magnetic trip setting for circuit-breaker frame sizes 250 A and smaller.
 2. 250 AMP and larger electronic trip circuit breakers with rms sensing; field-replaceable rating plug or field-replicable electronic trip; and the following field-adjustable settings:
 - a. Instantaneous trip.
 - b. Long- and short-time pickup levels.
 - c. Long- and short-time time adjustments.
 3. Molded-Case Circuit-Breaker (MCCB) Features and Accessories:
 - a. Standard frame sizes, trip ratings, and number of poles.
 - b. Lugs: Mechanical style, suitable for number, size, trip ratings, and conductor materials. Compression for Aluminum feeders.
 - c. Application Listing: Appropriate for application.
 - d. Handle Padlocking Device: Fixed attachment, for locking circuit-breaker handle in off position.

2.5 ACCESSORY COMPONENTS AND FEATURES

- A. Accessory Set: Include tools and miscellaneous items required for overcurrent protective device test, inspection, maintenance, and operation.
- B. Portable Test Set: For testing functions of solid-state trip devices without removing from panelboard. Include relay and meter test plugs suitable for testing panelboard meters and switchboard class relays.

PART 3 - EXECUTION

3.1 EXAMINATION

- A. Receive, inspect, handle, and store panelboards according to NECA 407.
- B. Examine panelboards before installation. Reject panelboards that are damaged or rusted or have been subjected to water saturation.
- C. Examine elements and surfaces to receive panelboards for compliance with installation tolerances and other conditions affecting performance of the Work.
- D. Proceed with installation only after unsatisfactory conditions have been corrected.

3.2 INSTALLATION

- A. Install panelboards and accessories according to NECA 407.
- B. Equipment Mounting: Install panelboards on concrete bases, 4-inch (100-mm) nominal thickness. Comply with requirements for concrete base specified in Division 03 Section "Miscellaneous Cast-in-Place Concrete."
 - 1. Install dowel rods to connect concrete base to concrete floor. Unless otherwise indicated, install dowel rods on 18-inch (450-mm) centers around full perimeter of base.
 - 2. For panelboards, install epoxy-coated anchor bolts that extend through concrete base and anchor into structural concrete floor.
 - 3. Place and secure anchorage devices. Use setting drawings, templates, diagrams, instructions, and directions furnished with items to be embedded.
 - 4. Install anchor bolts to elevations required for proper attachment to panelboards.
 - 5. Attach panelboard to the vertical finished or structural surface behind the panelboard.
- C. Temporary Lifting Provisions: Remove temporary lifting eyes, channels, and brackets and temporary blocking of moving parts from panelboards.
- D. Comply with mounting and anchoring requirements specified in Division 26 Section "Vibration and Seismic Controls for Electrical Systems."
- E. Mount top of trim 90 inches (2286 mm) above finished floor unless otherwise indicated.
- F. Mount panelboard cabinet plumb and rigid without distortion of box. Mount recessed panelboards with fronts uniformly flush with wall finish and mating with back box.
- G. Install overcurrent protective devices and controllers not already factory installed.
 - 1. Set field-adjustable, circuit-breaker trip ranges.
- H. Install filler plates in unused spaces.
- I. Stub four 1-inch empty conduits from recessed panelboards into accessible ceiling space or space designated to be ceiling space in the future. Stub four 1-inch empty conduits into raised floor space or below slab not on grade.
- J. Arrange conductors in gutters into groups and bundle and wrap with wire ties after completing load balancing.
- K. Comply with NECA 1.

3.3 IDENTIFICATION

- A. Identify field-installed conductors, interconnecting wiring, and components; provide warning signs complying with Division 26 Section "Identification for Electrical Systems."
- B. Create a directory to indicate installed circuit loads after balancing panelboard loads; incorporate Owner's final room designations. Obtain approval before installing. Use a computer software/spreadsheet to create directory; handwritten directories are not acceptable. Provide electronic files of directories to owner/architect with closeout documents.
- C. Panelboard Nameplates: Label each panelboard with a nameplate complying with requirements for identification specified in Division 26 Section "Identification for Electrical Systems."
- D. Device Nameplates: Label each branch circuit device in distribution panelboards with a nameplate complying with requirements for identification specified in Division 26 Section "Identification for Electrical Systems."

3.4 FIELD QUALITY CONTROL

- A. Manufacturer's Field Service: Engage a factory-authorized service representative to inspect, test, and adjust components, assemblies, and equipment installations, including connections.
- B. Acceptance Testing Preparation:
 - 1. Test insulation resistance for each panelboard bus, component, connecting supply, feeder, and control circuit.
 - 2. Test continuity of each circuit.
- C. Tests and Inspections:
 - 1. Perform each visual and mechanical inspection and electrical test stated in NETA Acceptance Testing Specification. Certify compliance with test parameters.
 - 2. Correct malfunctioning units on-site, where possible, and retest to demonstrate compliance; otherwise, replace with new units and retest.
 - 3. Perform the following infrared scan tests and inspections and prepare reports:
 - a. Initial Infrared Scanning: After Substantial Completion, but not more than 60 days after Final Acceptance, perform an infrared scan of each panelboard. Remove front panels so joints and connections are accessible to portable scanner.
 - b. Follow-up Infrared Scanning: Perform an additional follow-up infrared scan of each panelboard 11 months after date of Substantial Completion.
 - c. Instruments and Equipment:
 - 1) Use an infrared scanning device designed to measure temperature or to detect significant deviations from normal values. Provide calibration record for device.
- D. Panelboards will be considered defective if they do not pass tests and inspections.
- E. Prepare test and inspection reports, including a certified report that identifies panelboards included and that describes scanning results. Include notation of deficiencies detected, remedial action taken, and observations after remedial action.

3.5 ADJUSTING

- A. Adjust moving parts and operable component to function smoothly, and lubricate as recommended by manufacturer.
- B. Set field-adjustable circuit-breaker trip ranges as specified in Division 26 Section "Overcurrent Protective Device Coordination Study."
- C. Load Balancing: After Substantial Completion, but not more than 60 days after Final Acceptance, measure load balancing and make circuit changes.
 - 1. Measure as directed during period of normal system loading.
 - 2. Perform load-balancing circuit changes outside normal occupancy/working schedule of the facility and at time directed. Avoid disrupting critical 24-hour services such as fax machines and on-line data processing, computing, transmitting, and receiving equipment.
 - 3. After circuit changes, recheck loads during normal load period. Record all load readings before and after changes and submit test records.
 - 4. Tolerance: Difference exceeding 20 percent between phase loads, within a panelboard, is not acceptable. Rebalance and recheck as necessary to meet this minimum requirement.

3.6 PROTECTION

- A. Temporary Heating: Apply temporary heat to maintain temperature according to manufacturer's written instructions.

END OF SECTION

This page is intentionally left blank.

SECTION 26 27 26

WIRING DEVICES

PART 1 - GENERAL

1.1 RELATED DOCUMENTS

- A. Drawings and general provisions of the Contract, including General and Supplementary Conditions and Division 01 Specification Sections, apply to this Section.
- B. Section 01 81 13 "Sustainable Design Requirements – LEED v4 for Building Design & Construction – New Construction" for sustainable design requirements and detailed sustainable design submittal requirements.
- C. Section 01 74 19 "Construction and Demolition Waste Management and Disposal" for disposal of construction, demolition and packaging waste disposal requirements.

1.2 SUMMARY

- A. This Section includes the following:
 - 1. Receptacles, receptacles with integral GFCI, and associated device plates.
 - 2. Twist-locking receptacles.
 - 3. Wall-box motion sensors.
 - 4. Isolated-ground receptacles.
 - 5. Hospital-grade receptacles.
 - 6. Snap switches and wall-box dimmers.
 - 7. Wall-switch and exterior occupancy sensors.
 - 8. Floor service outlets, poke-through assemblies, service poles, and multioutlet assemblies.
- B. Sustainable Building Requirements:
 - 1. The Owner requires the Contractor to implement practices and procedures to meet the project's environmental performance goals, which include achieving LEED version 4 Certified level Certification. Specific project goals that may impact this area of work include: use of recycled-content materials; use of locally-manufactured materials; use of low-emitting materials; construction waste recycling; and the implementation of a construction indoor air quality management plan. The Contractor shall ensure that the requirements related to these goals, as defined in the Articles below, are implemented to the fullest extent. Substitutions, or other changes to the work proposed by the Contractor or their Subcontractors, shall not be allowed if such changes compromise the aforementioned environmental goals and LEED certification.

1.3 DEFINITIONS

- A. EMI: Electromagnetic interference.
- B. GFCI: Ground-fault circuit interrupter.
- C. Pigtail: Short lead used to connect a device to a branch-circuit conductor.
- D. RFI: Radio-frequency interference.
- E. TVSS: Transient voltage surge suppressor.
- F. UTP: Unshielded twisted pair.

1.4 SUBMITTALS

- A. Product Data: For each type of product indicated.
- B. Shop Drawings: List of legends and description of materials and process used for premarking wall plates.
- C. Samples: One for each type of device and wall plate specified, in each color specified.
- D. Field quality-control test reports.
- E. Operation and Maintenance Data: For wiring devices to include in all manufacturers' packing label warnings and instruction manuals that include labeling conditions.

1.5 QUALITY ASSURANCE

- A. Source Limitations: Obtain each type of wiring device and associated wall plate through one source from a single manufacturer. Insofar as they are available, obtain all wiring devices and associated wall plates from a single manufacturer and one source.
- B. Electrical Components, Devices, and Accessories: Listed and labeled as defined in NFPA 70, Article 100, by a testing agency acceptable to authorities having jurisdiction, and marked for intended use.
- C. Comply with NFPA 70.

1.6 COORDINATION

- A. Receptacles for Owner-Furnished Equipment: Match plug configurations.
 - 1. Cord and Plug Sets: Match equipment requirements.

1.7 EXTRA MATERIALS

- A. Furnish extra materials described in subparagraphs below that match products installed and that are packaged with protective covering for storage and identified with labels describing contents.
 - 1. Poke-Through, Fire-Rated Closure Plugs: One for every five floor service outlets installed, but no fewer than two.
 - 2. Receptacles and switches: One for every 10 of each type installed, but no fewer ten two of each type.

PART 2 - PRODUCTS

2.1 MANUFACTURERS

- A. Manufacturers' Names: Shortened versions (shown in parentheses) of the following manufacturers' names are used in other Part 2 articles:
 - 1. Hubbell Incorporated; Wiring Device-Kellems (Hubbell).
 - 2. Leviton Mfg. Company Inc. (Leviton).
 - 3. Pass & Seymour/Legrand; Wiring Devices & Accessories (Pass & Seymour).

2.2 STRAIGHT BLADE RECEPTACLES

- A. Convenience Receptacles, 125 V, 20 A: Comply with NEMA WD 1, NEMA WD 6 configuration 5-20R, and UL 498.
 - 1. Products: Subject to compliance with requirements, provide one of the following:
 - a. Hubbell; HBL5351 (single), CR5352 (duplex).
 - b. Leviton; 5891 (single), 5352 (duplex).
 - c. Pass & Seymour; 5381 (single), 5352 (duplex).
- B. Hospital-Grade, Duplex Convenience Receptacles, 125 V, 20 A: Comply with NEMA WD 1, NEMA WD 6 configuration 5-20R, and UL 498 Supplement SD.
 - 1. Products: Subject to compliance with requirements, provide one of the following:
 - a. Hubbell; HBL8310 (single), HBL8300H (duplex).
 - b. Leviton; 8310 (single), 8300 (duplex).
 - c. Pass & Seymour; 9301-HG (single), 9300-HG (duplex).
- C. Tamper-Resistant Convenience Receptacles, 125 V, 20 A: Comply with NEMA WD 1, NEMA WD 6 configuration 5-20R, and UL 498.
 - 1. Products: Subject to compliance with requirements, provide one of the following:

- a. Hubbell; HBL8300SG.
 - b. Leviton; 8300-SGG.
 - c. Pass & Seymour; 63H.
2. Description: Labeled to comply with NFPA 70, "Health Care Facilities" Article, "Pediatric Locations" Section.

2.3 GFCI RECEPTACLES

- A. General Description: Straight blade, non-feed-through type. Comply with NEMA WD 1, NEMA WD 6, UL 498, and UL 943, Class A, and include indicator light that is lighted when device is tripped.
- B. Hospital-Grade, Duplex GFCI Convenience Receptacles, 125 V, 20 A: Comply with UL 498 Supplement SD.
1. Products: Subject to compliance with requirements, provide one of the following:
 - a. Hubbell; HGF8300.
 - b. Leviton; 6898-HG.
 - c. Pass & Seymour; 2091-SHG.

2.4 TWIST-LOCKING RECEPTACLES

- A. Single Convenience Receptacles, 125 V, 20 A: Comply with NEMA WD 1, NEMA WD 6 configuration L5-20R, and UL 498.
1. Available Products: Subject to compliance with requirements, products that may be incorporated into the Work include, but are not limited to, the following:
 2. Products: Subject to compliance with requirements, provide one of the following:
 - a. Hubbell; HBL2310.
 - b. Leviton; 2310.
 - c. Pass & Seymour; L520-R.

2.5 TOGGLE SWITCHES

- A. Comply with NEMA WD 1 and UL 20.
- B. Switches, 120/277 V, 20 A:
1. Products: Subject to compliance with requirements, provide one of the following:
 - a. Hubbell; CS1221 (single pole), CS1222 (two pole), CS1223 (three way), CS1224 (four way).

- b. Leviton; 1221-2 (single pole), 1222-2 (two pole), 1223-2 (three way), 1224-2 (four way).
 - c. Pass & Seymour; 20AC1 (single pole), 20AC2 (two pole), 20AC3 (three way), 20AC4 (four way).
 - C. Pilot Light Switches, 20 A:
 - 1. Products: Subject to compliance with requirements, provide one of the following:
 - a. Hubbell; HPL1221PL for 120 V and 277 V.
 - b. Leviton; 1221-PLR for 120 V, 1221-7PLR for 277 V.
 - c. Pass & Seymour; PS20AC1-PLR for 120 V.
 - 2. Description: Single pole, with neon-lighted handle, illuminated when switch is "ON."
 - D. Key-Operated Switches, 120/277 V, 20 A:
 - 1. Products: Subject to compliance with requirements, provide one of the following:
 - a. Hubbell; HBL1221L.
 - b. Leviton; 1221-2L.
 - c. Pass & Seymour; PS20AC1-L.
 - 2. Description: Single pole, with factory-supplied key in lieu of switch handle.
 - E. Single-Pole, Double-Throw, Momentary Contact, Center-Off Switches, 120/277 V, 20 A; for use with mechanically held lighting contactors.
 - 1. Products: Subject to compliance with requirements, provide one of the following:
 - a. Hubbell; HBL1557.
 - b. Leviton; 1257.
 - c. Pass & Seymour; 1251.
- 2.6 WALL-BOX DIMMERS
- A. Dimmer Switches: Modular, full-wave, solid-state units with integral, quiet on-off switches, with audible frequency and EMI/RFI suppression filters.
 - B. Control: Continuously adjustable slider; with single-pole or three-way switching. Comply with UL 1472.
 - C. Incandescent Lamp Dimmers: 120 V; control shall follow square-law dimming curve. On-off switch positions shall bypass dimmer module.
 - 1. 600 W; dimmers shall require no derating when ganged with other devices. Illuminated when "OFF."

2.7 WALL PLATES

- A. Single and combination types to match corresponding wiring devices.
 - 1. Plate-Securing Screws: Metal with head color to match plate finish.
 - 2. Material for Finished Spaces: 0.035-inch- (1-mm-) thick, satin-finished stainless steel.
 - 3. Material for Unfinished Spaces: Galvanized steel.
 - 4. Material for Damp Locations: Cast aluminum with spring-loaded lift cover, and listed and labeled for use in "wet locations."
- B. Wet-Location, Weatherproof Cover Plates: NEMA 250, complying with type 3R weather-resistant with rain tight while in use covers.
- C. Coordinate colors and material with Architect.

2.8 FLOOR SERVICE FITTINGS

- A. Type: Modular, flush-type, dual-service units suitable for wiring method used.
- B. Compartments: Barrier separates power from voice and data communication cabling.
- C. Service Plate: Rectangular and round, die-cast aluminum with satin finish.
- D. Power Receptacle: NEMA WD 6 configuration 5-20R, gray finish, unless otherwise indicated.
- E. Voice and Data Communication Outlet: Two modular, keyed, color-coded, RJ-45 Category 6e jacks for UTP cable. Coordinate with Telcom drawings and specifications.
- F. Coordinate all finishes, materials and colors with architect.

2.9 POKE-THROUGH ASSEMBLIES

- A. Manufacturers: Subject to compliance with requirements, provide products by one of the following:
 - 1. Hubbell Incorporated; Wiring Device-Kellems.
 - 2. Pass & Seymour/Legrand; Wiring Devices & Accessories.
 - 3. Wiremold Company (The).
- B. Description: Factory-fabricated and -wired assembly of below-floor junction box with multichanneled, through-floor raceway/firestop unit and detachable matching floor service outlet assembly.
 - 1. Service Outlet Assembly: Flush type with four simplex receptacles and space for four RJ-45 jacks.

2. Size: Selected to fit nominal 4-inch (100-mm) cored holes in floor and matched to floor thickness.
3. Fire Rating: Unit is listed and labeled for fire rating of floor-ceiling assembly.
4. Closure Plug: Arranged to close unused 4-inch (100-mm) cored openings and reestablish fire rating of floor.
5. Wiring Raceways and Compartments: For a minimum of four No. 12 AWG conductors and a minimum of four, 4-pair, Category 6e voice and data communication cables.

2.10 MULTIOUTLET ASSEMBLIES

- A. Manufacturers: Subject to compliance with requirements, provide products by one of the following:
 1. Hubbell Incorporated; Wiring Device-Kellems.
 2. Wiremold Company (The).
- B. Components of Assemblies: Products from a single manufacturer designed for use as a complete, matching assembly of raceways and receptacles.
- C. Raceway Material: Aluminum.
- D. Wire: No. 12 AWG.

2.11 FINISHES

- A. Color: Wiring device catalog numbers in Section Text do not designate device color.
 1. Wiring Devices Connected to Normal Power System: As selected by Architect (White), unless otherwise indicated or required by NFPA 70 or device listing.
 2. Wiring Devices Connected to Emergency Power System: Red.
 3. TVSS Devices: Blue.
 4. Isolated-Ground Receptacles: Orange.

PART 3 - EXECUTION

3.1 INSTALLATION

- A. Comply with NECA 1, including the mounting heights listed in that standard, unless otherwise noted.
- B. Coordination with Other Trades:

1. Take steps to insure that devices and their boxes are protected. Do not place wall finish materials over device boxes and do not cut holes for boxes with routers that are guided by riding against outside of the boxes.
2. Keep outlet boxes free of plaster, drywall joint compound, mortar, cement, concrete, dust, paint, and other material that may contaminate the raceway system, conductors, and cables.
3. Install device boxes in brick or block walls so that the cover plate does not cross a joint unless the joint is troweled flush with the face of the wall.
4. Install wiring devices after all wall preparation, including painting, is complete.

C. Conductors:

1. Do not strip insulation from conductors until just before they are spliced or terminated on devices.
2. Strip insulation evenly around the conductor using tools designed for the purpose. Avoid scoring or nicking of solid wire or cutting strands from stranded wire.
3. The length of free conductors at outlets for devices shall meet provisions of NFPA 70, Article 300, without pigtails.
4. Existing Conductors:
 - a. Cut back and pigtail, or replace all damaged conductors.
 - b. Straighten conductors that remain and remove corrosion and foreign matter.
 - c. Pigtailing existing conductors is permitted provided the outlet box is large enough.

D. Device Installation:

1. Replace all devices that have been in temporary use during construction or that show signs that they were installed before building finishing operations were complete.
2. Keep each wiring device in its package or otherwise protected until it is time to connect conductors.
3. Do not remove surface protection, such as plastic film and smudge covers, until the last possible moment.
4. Connect devices to branch circuits using pigtails that are not less than 6 inches (152 mm) in length.
5. When there is a choice, use side wiring with binding-head screw terminals. Wrap solid conductor tightly clockwise, 2/3 to 3/4 of the way around terminal screw.
6. Use a torque screwdriver when a torque is recommended or required by the manufacturer.
7. When conductors larger than No. 12 AWG are installed on 15- or 20-A circuits, splice No. 12 AWG pigtails for device connections.
8. Tighten unused terminal screws on the device.
9. When mounting into metal boxes, remove the fiber or plastic washers used to hold device mounting screws in yokes, allowing metal-to-metal contact.

E. Receptacle Orientation:

1. Install ground pin of vertically mounted receptacles up, and on horizontally mounted receptacles to the right.
 2. Install hospital-grade receptacles in patient-care areas with the ground pin or neutral blade at the top.
- F. Device Plates: Do not use oversized or extra-deep plates. Repair wall finishes and remount outlet boxes when standard device plates do not fit flush or do not cover rough wall opening.
- G. Dimmers:
1. Install dimmers within terms of their listing.
 2. Verify that dimmers used for fan speed control are listed for that application.
 3. Install unshared neutral conductors on line and load side of dimmers according to manufacturers' device listing conditions in the written instructions.
- H. Arrangement of Devices: Unless otherwise indicated, mount flush, with long dimension vertical and with grounding terminal of receptacles on top. Group adjacent switches under single, multigang wall plates.
- I. Adjust locations of floor service outlets and service poles to suit arrangement of partitions and furnishings.

3.2 IDENTIFICATION

- A. Comply with Division 26 Section "Identification for Electrical Systems."
1. Receptacles: Identify panelboard and circuit number from which served. Use hot, stamped or engraved machine printing with black-filled lettering on face of plate, and durable wire markers or tags inside outlet boxes.

3.3 FIELD QUALITY CONTROL

- A. Perform tests and inspections and prepare test reports.
1. In healthcare facilities, prepare reports that comply with recommendations in NFPA 99.
 2. Test Instruments: Use instruments that comply with UL 1436.
 3. Test Instrument for Convenience Receptacles: Digital wiring analyzer with digital readout or illuminated LED indicators of measurement.
- B. Tests for Convenience Receptacles:
1. Line Voltage: Acceptable range is 105 to 132 V.
 2. Percent Voltage Drop under 15-A Load: A value of 6 percent or higher is not acceptable.
 3. Ground Impedance: Values of up to 2 ohms are acceptable.
 4. GFCI Trip: Test for tripping values specified in UL 1436 and UL 943.

5. Using the test plug, verify that the device and its outlet box are securely mounted.
 6. The tests shall be diagnostic, indicating damaged conductors, high resistance at the circuit breaker, poor connections, inadequate fault current path, defective devices, or similar problems. Correct circuit conditions, remove malfunctioning units and replace with new ones, and retest as specified above.
- C. Test straight blade hospital-grade convenience outlets for the retention force of the grounding blade according to NFPA 99. Retention force shall be not less than 4 oz. (115 g).

END OF SECTION

SECTION 26 28 16

ENCLOSED SWITCHES AND CIRCUIT BREAKERS

PART 1 - GENERAL

1.1 RELATED DOCUMENTS

- A. Drawings and general provisions of the Contract, including General and Supplementary Conditions and other Division 01 Specification Sections, apply to this Section.
- B. Section 01 81 13 "Sustainable Design Requirements – LEED v4 for Building Design & Construction – New Construction" for sustainable design requirements and detailed sustainable design submittal requirements.
- C. Section 01 74 19 "Construction and Demolition Waste Management and Disposal" for disposal of construction, demolition and packaging waste disposal requirements.

1.2 SUMMARY

- A. Section Includes:
 - 1. Fusible switches.
 - 2. Molded-case circuit breakers (MCCBs).
 - 3. Enclosures.
- B. Sustainable Building Requirements:
 - 1. The Owner requires the Contractor to implement practices and procedures to meet the project's environmental performance goals, which include achieving LEED version 4 Certified level Certification. Specific project goals that may impact this area of work include: use of recycled-content materials; use of locally-manufactured materials; use of low-emitting materials; construction waste recycling; and the implementation of a construction indoor air quality management plan. The Contractor shall ensure that the requirements related to these goals, as defined in the Articles below, are implemented to the fullest extent. Substitutions, or other changes to the work proposed by the Contractor or their Subcontractors, shall not be allowed if such changes compromise the aforementioned environmental goals and LEED certification.

1.3 DEFINITIONS

- A. NC: Normally closed.
- B. NO: Normally open.
- C. SPDT: Single pole, double throw.

1.4 PERFORMANCE REQUIREMENTS

Seismic Performance: Enclosed switches and circuit breakers shall withstand the effects of earthquake motions determined according to so that the unit will remain in place without separation of any parts from the device when subjected to the seismic forces specified and the unit will be fully operational after the seismic event."

1.5 SUBMITTALS

- A. Product Data: For each type of enclosed switch, circuit breaker, accessory, and component indicated. Include dimensioned elevations, sections, weights, and manufacturers' technical data on features, performance, electrical characteristics, ratings, accessories, and finishes.
 - 1. Enclosure types and details for types other than NEMA 250, Type 1.
 - 2. Current and voltage ratings.
 - 3. Short-circuit current ratings (interrupting and withstand, as appropriate).
 - 4. Include evidence of NRTL listing for series rating of installed devices.
 - 5. Detail features, characteristics, ratings, and factory settings of individual overcurrent protective devices, accessories, and auxiliary components.
 - 6. Include time-current coordination curves (average melt) for each type and rating of overcurrent protective device; include selectable ranges for each type of overcurrent protective device. Submit on translucent log-log graph paper.
- B. Shop Drawings: For enclosed switches and circuit breakers. Include plans, elevations, sections, details, and attachments to other work.
 - 1. Wiring Diagrams: For power, signal, and control wiring.
- C. Qualification Data: For qualified testing agency.
- D. Seismic Qualification Certificates: For enclosed switches and circuit breakers, accessories, and components, from manufacturer.
 - 1. Basis for Certification: Indicate whether withstand certification is based on actual test of assembled components or on calculation.
 - 2. Dimensioned Outline Drawings of Equipment Unit: Identify center of gravity and locate and describe mounting and anchorage provisions.
 - 3. Detailed description of equipment anchorage devices on which the certification is based and their installation requirements.
- E. Field quality-control reports.
 - 1. Test procedures used.
 - 2. Test results that comply with requirements.
 - 3. Results of failed tests and corrective action taken to achieve test results that comply with requirements.
- F. Manufacturer's field service report.
- G. Operation and Maintenance Data: For enclosed switches and circuit breakers to include in emergency, operation, and maintenance manuals. In addition to items specified in Division 01 Section "Operation and Maintenance Data," include the following:
 - 1. Manufacturer's written instructions for testing and adjusting enclosed switches and circuit breakers.

2. Time-current coordination curves (average melt) for each type and rating of overcurrent protective device; include selectable ranges for each type of overcurrent protective device. Submit on translucent log-log graph paper.

1.6 QUALITY ASSURANCE

- A. Testing Agency Qualifications: Member company of NETA or an NRTL.
 1. Testing Agency's Field Supervisor: Currently certified by NETA to supervise on-site testing.
- B. Source Limitations: Obtain enclosed switches and circuit breakers, overcurrent protective devices, components, and accessories, within same product category, from single source from single manufacturer.
- C. Product Selection for Restricted Space: Drawings indicate maximum dimensions for enclosed switches and circuit breakers, including clearances between enclosures, and adjacent surfaces and other items. Comply with indicated maximum dimensions.
- D. Electrical Components, Devices, and Accessories: Listed and labeled as defined in NFPA 70, by a qualified testing agency, and marked for intended location and application.
- E. Comply with NFPA 70.

1.7 PROJECT CONDITIONS

- A. Environmental Limitations: Rate equipment for continuous operation under the following conditions unless otherwise indicated:
 1. Ambient Temperature: Not less than minus 22 deg F (minus 30 deg C) and not exceeding 104 deg F (40 deg C).
 2. Altitude: Not exceeding 6600 feet (2010 m).

1.8 COORDINATION

- A. Coordinate layout and installation of switches, circuit breakers, and components with equipment served and adjacent surfaces. Maintain required workspace clearances and required clearances for equipment access doors and panels.

1.9 EXTRA MATERIALS

- A. Furnish extra materials that match products installed and that are packaged with protective covering for storage and identified with labels describing contents.
 1. Fuses: Equal to 10 percent of quantity installed for each size and type, but no fewer than three of each size and type.
 2. Fuse Pullers: two for each size and type.

PART 2 - PRODUCTS

2.1 FUSIBLE SWITCHES

- A. Basis-of-Design Product: Subject to compliance with requirements, provide or comparable product by one of the following:

1. Eaton Electrical Inc.; Cutler-Hammer Business Unit.
 2. General Electric Company; GE Consumer & Industrial - Electrical Distribution.
 3. Siemens Energy & Automation, Inc.
 4. Square D; a brand of Schneider Electric.
- B. Type HD, Heavy Duty, Single Throw, 600-V ac, 800 A and Smaller: UL 98 and NEMA KS 1, horsepower rated, with clips or bolt pads to accommodate specified fuses, lockable handle with capability to accept three padlocks, and interlocked with cover in closed position.
- C. Accessories:
1. Equipment Ground Kit: Internally mounted and labeled for copper and aluminum ground conductors.
 2. Neutral Kit: Internally mounted; insulated, capable of being grounded and bonded; labeled for copper and aluminum neutral conductors.
 3. Isolated Ground Kit: Internally mounted; insulated, capable of being grounded and bonded; labeled for copper and aluminum neutral conductors.
 4. Class R Fuse Kit: Provides rejection of other fuse types when Class R fuses are specified.
 5. Auxiliary Contact Kit: Two NO/NC (Form "C") auxiliary contact(s), arranged to activate before switch blades open.
 6. Hookstick Handle: Allows use of a hookstick to operate the handle.
 7. Lugs: Mechanical type, suitable for number, size, and conductor material.
 8. Service-Rated Switches: Labeled for use as service equipment.
 9. Accessory Control Power Voltage: Remote mounted and powered.

2.2 MOLDED-CASE CIRCUIT BREAKERS

- A. Basis-of-Design Product: Subject to compliance with requirements, provide or comparable product by one of the following:
1. Eaton Electrical Inc.; Cutler-Hammer Business Unit.
 2. General Electric Company; GE Consumer & Industrial - Electrical Distribution.
 3. Siemens Energy & Automation, Inc.
 4. Square D; a brand of Schneider Electric.
- B. General Requirements: Comply with UL 489, NEMA AB 1, and NEMA AB 3, with interrupting capacity to comply with available fault currents.
- C. Thermal-Magnetic Circuit Breakers: Inverse time-current element for low-level overloads and instantaneous magnetic trip element for short circuits. Adjustable magnetic trip setting for circuit-breaker frame sizes 250 A and larger.
- D. Adjustable, Instantaneous-Trip Circuit Breakers: Magnetic trip element with front-mounted, field-adjustable trip setting.
- E. Electronic Trip Circuit Breakers: Field-replaceable rating plug, rms sensing, with the following field-adjustable settings:
1. Instantaneous trip.
 2. Long- and short-time pickup levels.
 3. Long- and short-time time adjustments.
 4. Ground-fault pickup level, time delay, and I^2t response.
- F. Current-Limiting Circuit Breakers: Frame sizes 400 A and smaller, and let-through ratings less than NEMA FU 1, RK-5.

- G. Integrally Fused Circuit Breakers: Thermal-magnetic trip element with integral limiter-style fuse listed for use with circuit breaker and trip activation on fuse opening or on opening of fuse compartment door.
- H. Ground-Fault, Circuit-Interrupter (GFCI) Circuit Breakers: Single- and two-pole configurations with Class A ground-fault protection (6-mA trip).
- I. Ground-Fault, Equipment-Protection (GFEP) Circuit Breakers: With Class B ground-fault protection (30-mA trip).
- J. Features and Accessories:
 - 1. Standard frame sizes, trip ratings, and number of poles.
 - 2. Lugs: Mechanical type, suitable for number, size, trip ratings, and conductor material.
 - 3. Application Listing: Appropriate for application; Type SWD for switching fluorescent lighting loads; Type HID for feeding fluorescent and high-intensity discharge lighting circuits.
 - 4. Ground-Fault Protection: Comply with UL 1053; integrally mounted, self-powered type with mechanical ground-fault indicator; relay with adjustable pickup and time-delay settings, push-to-test feature, internal memory, and shunt trip unit; and three-phase, zero-sequence current transformer/sensor.
 - 5. Communication Capability: Integral communication module with functions and features compatible with power monitoring and control system, specified in Division 26 Section "Electrical Power Monitoring and Control."
 - 6. Shunt Trip: Trip coil energized from separate circuit, with coil-clearing contact.
 - 7. Undervoltage Trip: Set to operate at 35 to 75 percent of rated voltage without intentional time delay.
 - 8. Auxiliary Contacts: Two SPDT switches with "a" and "b" contacts; "a" contacts mimic circuit-breaker contacts, "b" contacts operate in reverse of circuit-breaker contacts.
 - 9. Alarm Switch: One NC contact that operates only when circuit breaker has tripped.
 - 10. Key Interlock Kit: Externally mounted to prohibit circuit-breaker operation; key shall be removable only when circuit breaker is in off position.
 - 11. Electrical Operator: Provide remote control for on, off, and reset operations.
 - 12. Accessory Control Power Voltage: 1 integrally mounted, self powered 120-V ac

2.3 ENCLOSURES

- A. Enclosed Switches and Circuit Breakers: NEMA AB 1, NEMA KS 1, NEMA 250, and UL 50, to comply with environmental conditions at installed location.
 - 1. Indoor, Dry and Clean Locations: NEMA 250, Type 1.
 - 2. Outdoor Locations: NEMA 250, Type 3R.
 - 3. Kitchen Wash-Down Areas: NEMA 250, Type 4X.
 - 4. Other Wet or Damp, Indoor Locations: NEMA 250, Type 4.
 - 5. Indoor Locations Subject to Dust, Falling Dirt, and Dripping Noncorrosive Liquids: NEMA 250, Type 12.
 - 6. Hazardous Areas: NEMA 250, Type 9.

PART 3 - EXECUTION

3.1 EXAMINATION

- A. Examine elements and surfaces to receive enclosed switches and circuit breakers for compliance with installation tolerances and other conditions affecting performance of the Work.
- B. Proceed with installation only after unsatisfactory conditions have been corrected.

3.2 INSTALLATION

- A. Install individual wall-mounted switches and circuit breakers with tops at uniform height unless otherwise indicated.
- B. Comply with mounting and anchoring requirements specified in Division 26 Section "Vibration and Seismic Controls for Electrical Systems."
- C. Temporary Lifting Provisions: Remove temporary lifting eyes, channels, and brackets and temporary blocking of moving parts from enclosures and components.
- D. Install fuses in fusible devices.
- E. Comply with NECA 1.

3.3 IDENTIFICATION

- A. Comply with requirements in Division 26 Section "Identification for Electrical Systems."
 - 1. Identify field-installed conductors, interconnecting wiring, and components; provide warning signs.
 - 2. Label each enclosure with engraved metal or laminated-plastic nameplate.

3.4 FIELD QUALITY CONTROL

- A. Manufacturer's Field Service: Engage a factory-authorized service representative to inspect, test, and adjust components, assemblies, and equipment installations, including connections.
- B. Acceptance Testing Preparation:
 - 1. Test insulation resistance for each enclosed switch and circuit breaker, component, connecting supply, feeder, and control circuit.
 - 2. Test continuity of each circuit.
 - 3. Perform over current trip test for circuit breakers over 200 amps based on NEMA standards. The use of secondary injection for solid state trip devices shall be for trip settings of 200 amps up to 400A. Provide primary injection testing for trip settings over 400 amps.
- C. Tests and Inspections:
 - 1. Perform each visual and mechanical inspection and electrical test stated in NETA Acceptance Testing Specification. Certify compliance with test parameters.
 - 2. Correct malfunctioning units on-site, where possible, and retest to demonstrate compliance; otherwise, replace with new units and retest.
 - 3. Perform the following infrared scan tests and inspections and prepare reports:

- a. Initial Infrared Scanning: After Substantial Completion, but not more than 60 days after Final Acceptance, perform an infrared scan of each enclosed switch and circuit breaker. Remove front panels so joints and connections are accessible to portable scanner.
 - b. Follow-up Infrared Scanning: Perform an additional follow-up infrared scan of each enclosed switch and circuit breaker 11 months after date of Substantial Completion.
 - c. Instruments and Equipment: Use an infrared scanning device designed to measure temperature or to detect significant deviations from normal values. Provide calibration record for device.
4. Test and adjust controls, remote monitoring, and safeties. Replace damaged and malfunctioning controls and equipment.
- D. Enclosed switches and circuit breakers will be considered defective if they do not pass tests and inspections.
- E. Prepare test and inspection reports, including a certified report that identifies enclosed switches and circuit breakers and that describes scanning results. Include notation of deficiencies detected, remedial action taken, and observations after remedial action.
- 3.5 ADJUSTING
- A. Adjust moving parts and operable components to function smoothly, and lubricate as recommended by manufacturer.
 - B. Set field-adjustable circuit-breaker trip ranges as specified in Division 26 Section "Overcurrent Protective Device Coordination Study".

END OF SECTION

This page is intentionally left blank.

SECTION 26 41 13

LIGHTNING PROTECTION SYSTEM

PART 1 - GENERAL

1.1 RELATED DOCUMENTS

- A. All of the Contract Documents, as listed on the Table of Contents and including General and Supplementary Conditions and Division 1, General Requirements, shall be included in, and made part of, this Section.
- B. Section 01 81 13 "Sustainable Design Requirements – LEED v4 for Building Design & Construction – New Construction" for sustainable design requirements and detailed sustainable design submittal requirements.
- C. Section 01 74 19 "Construction and Demolition Waste Management and Disposal" for disposal of construction, demolition and packaging waste disposal requirements.

1.2 DESCRIPTION OF WORK

- A. Provide a complete lightning protection system with all component parts as indicated and/or specified, and as manufactured by Boston Lightning Rod, Inc., Northeast Lightning Protection Systems, Inc., Bloomfield, Connecticut, National Lightning Protection Corporation, Warren Lightning Rod Co., Collingwood, New Jersey, or an approved equal.
- B. Equipment furnished by one of the above manufacturers or an independent protection company shall be considered as equals.
- C. The system shall include air terminals on the roof and rooftop helipad; bonding of roof mounted mechanical equipment and stacks; bonding of structure and other metal parts, ground conductors and ground rods; with necessary connectors, bonding straps, fasteners, clamps and all other equipment and materials necessary for a complete system for the building.
- D. Sustainable Building Requirements:
 - 1. The Owner requires the Contractor to implement practices and procedures to meet the project's environmental performance goals, which include achieving LEED version 4 Certified level Certification. Specific project goals that may impact this area of work include: use of recycled-content materials; use of locally-manufactured materials; use of low-emitting materials; construction waste recycling; and the implementation of a construction indoor air quality management plan. The Contractor shall ensure that the requirements related to these goals, as defined in the Articles below, are implemented to the fullest extent. Substitutions, or other changes to the work proposed by the Contractor or their Subcontractors, shall not be allowed if such changes compromise the aforementioned environmental goals and LEED certification.

1.3 RELATED WORK

- A. For work to be included as part of this Section, to be furnished and installed by the Electrical Subcontractor, refer to the Related Work section of Specification Section 16010.
- B. Carefully examine all of the Contract Documents, criteria sheets and all other Sections of the specifications for requirements which affect work under this Section, whether or not such work is specifically mentioned in this Section.
- C. For work related to, and to be coordinated with the electrical work, but not included in this Section and required to be performed under other designated Sections, see the following:
 - 1. Section xxxxxx –Roofing Systems

1.4 REFERENCES

- A. The lightning protection system and all components shall be designed, manufactured and installed in accordance with the latest applicable standards as follows:
 - 1. ANSI/NFPA 780 - Lightning Protection Code
 - 2. ANSI/UL 96 - Lightning Protection Components
 - 3. UL 96A - Installation Requirements for Lightning Protection
- B. The system shall be designed and installed in accordance with the requirements of NFPA 780 and UL 96A to obtain Master Label on the building.

1.5 WARRANTY

- A. Attention is directed to provisions of the General Requirements, Supplementary General Requirements, Section xxxxxx – Warranties and Section xxxxxx Electrical Special Conditions regarding guarantees and warranties for work under this Contract.

1.6 QUALIFICATIONS

- A. Manufacturer shall be a company specializing in lightning protection equipment, with minimum of (10) years documented experience and listed in UL's Electrical Construction Materials Directory or Supplement under Lightning Protection - Lightning Conductor, Air Terminals and Fittings.
- B. Installer shall be authorized installer of manufacturer with minimum of (10) years of documented experience and listed in UL's Electrical Construction Materials Directory or Supplement under Lightning Protection - Lightning Protection Installation.

1.7 SUBMITTALS

- A. Prepare and submit shop drawings and product data in accordance with the requirements hereinbefore specified and with the Shop Drawings, Product Data and Samples Section 01330 in the manner described therein, modified as noted hereinafter.

- B. Submit shop drawings showing layout of air terminals, grounding electrodes, and bonding connections to structure and other metal objects. Include terminal, electrode and conductor sizes, and connection and termination details.
- C. Submit product data showing dimensions and materials of each component, and include indication of listing in accordance with ANSI/UL 96.
- D. The manufacturer/installer shall submit for approval one reproducible drawing of installation drawings of each building, indicating all work required for this item including ground rod locations, air terminal locations and cable locations. Catalog cuts of all components shall also be submitted for approval to the Architect/Engineer. Three (3) prints of drawings shall be submitted for approval and (5) prints shall be submitted after approval.
- E. Submit manufacturer's installation instructions under provisions of Section 01300.

1.8 PROJECT RECORD DOCUMENTS

- A. Submit project Record Documents.
- B. Accurately record actual locations of air terminals, grounding electrodes, bonding connections, and routing of system conductors.

1.9 SEQUENCE AND SCHEDULING

- A. Coordinate work under provisions of Section xxxxxx.
- B. Coordinate the work of this Section with roofing and exterior and interior finish installation.

PART 2 - PRODUCTS

2.1 MATERIALS

- A. Materials shall be new and first quality commercial products. Standard fittings shall be used where practicable, in preference to special fittings.
- B. Materials shall comply in weight, size and composition with the requirements of ANSI/UL 96 and the NFPA Code relating to this type of structure.
- C. Lightning rod equipment and fittings shall bear the UL label.

2.2 AIR TERMINALS

- A. Air terminals shall be one-piece, lead coated, solid copper.
- B. Air terminals mounted on flat roofs shall be minimum 24" in height.

2.3 AIR TERMINAL BASES

- A. Air terminal bases shall provide a secure attachment to the structure, the air terminal and the conductor cable. The base shall be compatible with all (3) items in contact with it.

2.4 CONDUCTORS

- A. Ground and bonding conductors shall be soft drawn copper with a conductivity of at least 95% of pure copper.

2.5 CONNECTOR FITTINGS

- A. A connector fitting shall be constructed so that a minimum of 1 1/2" of each conductor can be secured within the connector. It shall be compatible with the material being secured.
- B. Water pipe connectors shall be constructed so as to provide at least 1 1/2" contact with the water pipe and conductor. It shall be compatible with the water pipe and conductor materials or be lead coated to form a bimetallic connection.

2.6 CLIPS

- A. Clips for securing copper conductors shall be not less than 0.032" thick and not less than 3/8" wide. Clips shall be placed not more than 3'-0" apart along a conductor.

2.7 GROUND ROD CLAMPS

- A. Ground rod clamps shall be not less than 3/32" thick, contact the ground rod and conductor not less than 1 1/2" and be secured with at least (2) bolts.

2.8 GROUND ELECTRODES

- A. Ground electrodes shall be as specified of proper size and material compatible with ground conditions and to obtain the desired minimum ground resistance.

2.9 FASTENERS

- A. Fasteners shall be compatible with the materials being secured and of a size and type specified.

2.10 CADWELD

- A. Bonding of lightning protection systems to building steel, ground rods, cable connections, all connections below grade, etc. shall utilize Cadweld exothermic grounding connections

PART 3 - EXECUTION

3.1 COOPERATION AND WORK PROGRESS

- A. The Electrical work shall be carried on under the usual construction conditions, in conjunction with all other work at the site. The Electrical Subcontractor shall cooperate with the Architect, General Contractor, all other Subcontractors and equipment suppliers working at the site. The Electrical Subcontractor shall coordinate the work and proceed in a manner so as not to delay the progress of the project.

- B. The Electrical Subcontractor shall coordinate his work with the progress of the building and other Trades so that he will complete his work as soon as conditions permit and such that interruptions of the building functions will be at a minimum. Any overtime hours worked or additional costs incurred due to lack of or improper coordination with other Trades or the Owner by the Electrical Subcontractor, shall be assumed by him without any additional cost to the Owner.
- C. The Electrical Subcontractor shall furnish information on all equipment that is furnished under this Section but installed under another Section to the installing Subcontractor as specified herein.
- D. The Electrical Subcontractor shall provide all materials, equipment and workmanship to provide for adequate protection of all electrical equipment during the course of construction of the project. This shall also include protection from moisture and all foreign matter. The Electrical Subcontractor shall also be responsible for damage which he causes to the work of other Trades, and he shall remedy such injury at his own expense.
- E. Waste materials shall be removed promptly from the premises. All material and equipment stored on the premises shall be kept in a neat and orderly fashion. Material or equipment shall not be stored where exposed to the weather. The Electrical Subcontractor shall be responsible for the security, safekeeping and damages, including acts of vandalism, of all material and equipment stored at the job site.
- F. The Electrical Subcontractor shall be responsible for unloading all electrical equipment and materials delivered to the site. This shall also include all large and heavy items or equipment which require hoisting. Consult with the General Contractor for hoisting/crane requirements. During construction of the building, the Electrical Subcontractor shall provide additional protection against moisture, dust accumulation and physical damage of the main service and distribution equipment. This shall include furnishing and installing temporary heaters within these units, as approved, to evaporate excessive moisture and ventilate it from the room, as may be required.
- G. It shall be the responsibility of the Electrical Subcontractor to coordinate the delivery of the electrical equipment to the project prior to the time installation of equipment will be required; but he shall also make sure such equipment is not delivered too far in advance of such required installation, to ensure that possible damage and deterioration of such equipment will not occur. Such equipment stored for an excessively long period of time (as determined in the opinion of the Architect) on the project site prior to installation may be subject to rejection by the Architect.
- H. The Electrical Subcontractor shall erect and maintain, at all times, necessary safeguards for the protection of life and property of the Owner, Workmen, Staff and the Public.
- I. Prior to installation, the Electrical Subcontractor has the responsibility to coordinate the exact mounting arrangement and location of electrical equipment to allow proper space requirements as indicated in the NEC. Particular attention shall be given in the field to group installations. If it is questionable that sufficient space, conflict with the work of other Subcontractors, architectural or structural obstructions will result in an arrangement which will prevent proper access, operation or maintenance of the indicated equipment, the Electrical Subcontractor

shall immediately notify the Contractor and not proceed with this part of the Contract work until definite instructions have been given to him by the Architect.

3.2 INSTALLATION

A. General

1. Unless specifically noted or indicated otherwise, all equipment and material specified in Part 2 of this specification or indicated on the drawings shall be installed under this Contract whether or not specifically itemized herein. This Section covers particular installation methods and requirements peculiar to certain items and classes of material and equipment.
2. The Electrical Subcontractor shall obtain detailed information from manufacturers of equipment provided under Part 2 of this specification as to proper methods of installation.
3. The Electrical Subcontractor shall obtain final roughing dimensions and other information as needed for complete installation of items furnished under other Sections or furnished by the Owner.
4. The Electrical Subcontractor shall keep fully informed of size, shape and position of openings required for material and equipment provided under this and other Sections. Ensure that openings required for work of this Section are coordinated with work of other Sections. Provide cutting and patching as necessary.
5. All miscellaneous hardware and support accessories, including support rods, nuts, bolts, screws and other such items, shall be of a galvanized or cadmium plated finish or of another approved rust-inhibiting coating.
6. The lightning protection system shall be installed in accordance with the current edition of UL 96A "Installation Requirements for Master Labeled Lightning Protection Systems".
 - a. No ferrous fasteners (except stainless steel), nor ferrous holding devices of any kind shall be employed as permanent fasteners.
 - b. Individual anchor bolts, employed in this installation, shall each have a pull-out resistance of not less than 100 pounds as determined by actual test.
 - c. The installation shall be made in a most conspicuous manner. Conductors shall be coursed on the back side of architectural construction to conceal equipment as much as possible.

B. Air Terminal Installation

1. Air terminals shall be installed as required by UL.
2. Air terminals shall have their points aligned vertically, and their bases shall be bolted or welded to the building.

C. Conductor Installation

1. Down conductors shall be installed on buildings at intervals of 100'-0" on center, maximum. When structural building steel is used instead of down conductors, the ground conductor interval shall not average over 60'-0" on center.
2. Conductors shall be connected to the ground rods with ground clamps allowing a reasonable amount of slack conductor to allow for expansion and contraction. Steel surfaces shall be clean and bright before applying connector plates or Cadwelding. Bends in these conductors shall have no angle more than 90°. Bends shall have a radius of not less than 8".

Connectors shall, when fixed to conductors, be capable of withstanding a pull of 200 pounds.

3. Bonding conductors shall be connected to the bonding clamps allowing a reasonable amount of slack for expansion and contraction, and the conductor bonds shall be limited as stated above.
4. All metal fascia, television masts, ventilators, vents, roof drains, stacks, etc. shall be grounded.

D. Ground Installation

1. Ground terminal installation shall be made at all locations indicated on the drawings and at such other points as may be found necessary to properly ground the system.
2. All grounds shall be made by means of rods driven into the soil which shall penetrate vertically not less than 10'-0" below the finished surface of the ground and passing approximately 2'-0" away from the building foundations.
3. The Electrical Subcontractor shall add to the ground system in case the measured resistance exceeds 50 ohms per electrode, at the direction of the Architect/Engineer and at no additional cost to the Owner.
4. A stamped tag of non-corrosive metal shall be attached to the metal support for each building adjacent to each ground connection, to indicate the location and arrangement of the rods and final value of the resistance at time of installation. An as-built drawing and record of resistance values shall be submitted in addition to the stamped tag.

E. Grounding Cable Connections

1. All grounding cable connections to ground rods, structural steel and splices shall be of the exothermic welding process.

- F. Where cables penetrate the roofing membrane, penetrations shall be permanently sealed per roof manufacturer's recommended methods by the Roofing Subcontractor.

3.3 EXAMINATION

- A. Verify that surfaces are ready to receive work.
- B. Verify that field measurements are as shown on the drawings.
- C. Beginning of installation shall mean installer accepts existing conditions.

3.4 PROTECTION OF SURROUNDING ELEMENTS

- A. Protect elements surrounding work of this Section from damage or disfiguration.

3.5 ROOF TOP HELIPADS

- A. Roof top helipads on a protected structure shall be protected in accordance with. This section.
- B. The metal frame of the structure or the metal frame of the safety net at the perimeter of the pad shall be permitted to serve as a strike termination device.
- C. If adjacent sections of the perimeter metal frame or metal frame of the safety net are not electrically continuous through their mounting system, they shall be connected together with a main-size conductor.

- D. Where lights are installed at the perimeter of the pad and extend above the edge of the helipad, air terminals shall be installed adjacent to the fixture.
- E. The structural metal frame of the helipad shall be connected to the lightning protection system at a minimum of two places in accordance with 4.19.3.
- F. Connections shall be installed at intervals not to exceed an average of 100 ft (30 m) around the perimeter of the pad, as widely spaced as practicable.
- G. Clamps and conductors shall be installed at or below the elevation of the safety net frame.
- H. Clamps and conductors shall be secured against vibration and rotor wash.
- I. All exposed components shall be nonreflective or treated with a nonreflective finish.
- J. Helipads used for parking shall have a designated point to connect the helicopter to the lightning protection system while parked.
- K. All components of the lightning protection and grounding systems shall be located so as not to interfere with helicopter operations.

3.6 FIELD QUALITY CONTROL

- A. Field inspection and testing will be performed under provisions of Section xxxx.
- B. Obtain the services of UL to provide inspection and certification of the lightning protection system under provisions of UL 96A.
- C. Obtain UL Master Label and attach to building at the location prescribed by UL 96A.

END OF SECTION

SECTION 265100

INTERIOR LIGHTING

PART 1 - GENERAL

1.1 RELATED DOCUMENTS

- A. Drawings and general provisions of the Contract, including General and Supplementary Conditions and Division 01 Specification Sections, apply to this Section.
- B. Section 01 81 13 "Sustainable Design Requirements – LEED v4 for Building Design & Construction – New Construction" for sustainable design requirements and detailed sustainable design submittal requirements.
- C. Section 01 74 19 "Construction and Demolition Waste Management and Disposal" for disposal of construction, demolition and packaging waste disposal requirements.

1.2 SUMMARY

- A. This Section includes the following:
 - 1. Interior lighting fixtures and drivers.
 - 2. Exit signs.
 - 3. Lighting fixture supports.
- B. Related Sections include the following:
 - 1. Division 26 Section "Wiring Devices" for manual wall-box dimmers for incandescent lamps.
- C. Sustainable Building Requirements:
 - 1. The Owner requires the Contractor to implement practices and procedures to meet the project's environmental performance goals, which include achieving LEED version 4 Certified level Certification. Specific project goals that may impact this area of work include: use of recycled-content materials; use of locally-manufactured materials; use of low-emitting materials; construction waste recycling; and the implementation of a construction indoor air quality management plan. The Contractor shall ensure that the requirements related to these goals, as defined in the Articles below, are implemented to the fullest extent. Substitutions, or other changes to the work proposed by the Contractor or their Subcontractors, shall not be allowed if such changes compromise the aforementioned environmental goals and LEED certification.

1.3 DEFINITIONS

- A. CRI: Color-rendering index.
- B. CU: Coefficient of utilization.
- C. LER: Luminaire efficacy rating.
- D. Luminaire: Complete lighting fixture including driver.

- E. RCR: Room cavity ratio.

1.4 SUBMITTALS

- A. Product Data: For each type of lighting fixture, arranged in order of fixture designation. Include data on features, accessories, finishes, and the following:
 - 1. Physical description of lighting fixture including dimensions.
 - 2. LED Drivers
 - 3. Energy-efficiency data.
 - 4. Air and Thermal Performance Data: For air-handling lighting fixtures. Furnish data required in "Submittals" Article in Division 23 Section "Diffusers, Registers, and Grilles."
 - 5. Sound Performance Data: For air-handling lighting fixtures. Indicate sound power level and sound transmission class in test reports certified according to standards specified in Division 23 Section "Diffusers, Registers, and Grilles."
 - 6. Photometric data, in IESNA format, based on laboratory tests of each lighting fixture type, outfitted with lamps, ballasts, and accessories identical to those indicated for the lighting fixture as applied in this Project.
 - a. For indicated fixtures, photometric data shall be certified by a qualified independent testing agency. Photometric data for remaining fixtures shall be certified by the manufacturer.
 - b. Photometric data shall be certified by a manufacturer's laboratory with a current accreditation under the National Voluntary Laboratory Accreditation Program (NVLAP) for Energy Efficient Lighting Products.
- B. Shop Drawings: Show details of nonstandard or custom lighting fixtures. Indicate dimensions, weights, methods of field assembly, components, features, and accessories.
 - 1. Wiring Diagrams: Power and control wiring.
- C. Coordination Drawings: Reflected ceiling plan(s) and other details, drawn to scale, on which the following items are shown and coordinated with each other, based on input from installers of the items involved:
 - 1. Lighting fixtures.
 - 2. Suspended ceiling components.
 - 3. Structural members to which suspension systems for lighting fixtures will be attached.
 - 4. Other items in finished ceiling including the following:
 - a. Air outlets and inlets.
 - b. Speakers.
 - c. Sprinklers.
 - d. Smoke and fire detectors.
 - e. Occupancy sensors.
 - f. Access panels.
 - 5. Perimeter moldings.
- D. Samples for Verification: Interior lighting fixtures designated for sample submission in Interior Lighting Fixture Schedule. Each sample shall include the following:
 - 1. Lamps: Specified units installed.
 - 2. Accessories: Cords and plugs.
- E. Product Certificates: For each type of bi-level and dimmer-controlled fixtures, signed by product manufacturer.

- F. Qualification Data: For agencies providing photometric data for lighting fixtures.
- G. Field quality-control test reports.
- H. Operation and Maintenance Data: For lighting equipment and fixtures to include in emergency, operation, and maintenance manuals.
- I. Warranties: Special warranties specified in this Section.

1.5 QUALITY ASSURANCE

- A. Luminaire Photometric Data Testing Laboratory Qualifications: Provided by manufacturers' laboratories that are accredited under the National Volunteer Laboratory Accreditation Program for Energy Efficient Lighting Products.
- B. Luminaire Photometric Data Testing Laboratory Qualifications: Provided by an independent agency, with the experience and capability to conduct the testing indicated, that is an NRTL as defined by OSHA in 29 CFR 1910.7.
- C. Electrical Components, Devices, and Accessories: Listed and labeled as defined in NFPA 70, Article 100, by a testing agency acceptable to authorities having jurisdiction, and marked for intended use.
- D. Comply with NFPA 70.
- E. FMG Compliance: Lighting fixtures for hazardous locations shall be listed and labeled for indicated class and division of hazard by FMG.
- F. Mockups: Provide interior lighting fixtures for room or module mockups, complete with power and control connections.
 - 1. Obtain Architect's approval of fixtures for mockups before starting installations.
 - 2. Maintain mockups during construction in an undisturbed condition as a standard for judging the completed Work.
 - 3. Approved fixtures in mockups may become part of the completed Work if undisturbed at time of Substantial Completion.

1.6 COORDINATION

- A. Coordinate layout and installation of lighting fixtures and suspension system with other construction that penetrates ceilings or is supported by them, including HVAC equipment, fire-suppression system, and partition assemblies.

1.7 WARRANTY

- A. Special Warranty for Drivers: Manufacturer's standard form in which driver manufacturer agrees to repair or replace driver/fixture that fail in materials or workmanship within specified warranty period.
 - 1. Warranty Period for LED Drivers: Five years from date of Substantial Completion.

1.8 EXTRA MATERIALS

- A. Furnish extra materials described below that match products installed and that are packaged with protective covering for storage and identified with labels describing contents.

1. Plastic Diffusers and Lenses: 1 for every 100 of each type and rating installed. Furnish at least one of each type.
2. Drivers: 1 for every 100 of each type and rating installed. Furnish at least one of each type.
3. Globes and Guards: 1 for every 20 of each type and rating installed. Furnish at least one of each type.

PART 2 - PRODUCTS

2.1 MANUFACTURERS

- A. In other Part 2 articles where titles below introduce lists, the following requirements apply to product selection:
- B. In Interior Lighting Fixture Schedule where titles below are column or row headings that introduce lists, the following requirements apply to product selection:
 1. Manufacturers: Subject to compliance with requirements, provide products by one of the manufacturers specified.

2.2 LIGHTING FIXTURES AND COMPONENTS, GENERAL REQUIREMENTS

- A. Recessed Fixtures: Comply with NEMA LE 4 for ceiling compatibility for recessed fixtures.
- B. LED Fixtures: Comply with UL 8750.
- C. Metal Parts: Free of burrs and sharp corners and edges.
- D. Sheet Metal Components: Steel, unless otherwise indicated. Form and support to prevent warping and sagging.
- E. Doors, Frames, and Other Internal Access: Smooth operating, free of light leakage under operating conditions, and designed to permit relamping without use of tools. Designed to prevent doors, frames, lenses, diffusers, and other components from falling accidentally during relamping and when secured in operating position.
- F. Reflecting surfaces shall have minimum reflectance as follows, unless otherwise indicated:
 1. White Surfaces: 85 percent.
 2. Specular Surfaces: 83 percent.
 3. Diffusing Specular Surfaces: 75 percent.
 4. Laminated Silver Metallized Film: 90 percent.
- G. Plastic Diffusers, Covers, and Globes:
 1. Acrylic Lighting Diffusers: 100 percent virgin acrylic plastic. High resistance to yellowing and other changes due to aging, exposure to heat, and UV radiation.
 - a. Lens Thickness: At least 0.125 inch minimum unless different thickness is indicated.
 - b. UV stabilized.
 2. Glass: Annealed crystal glass, unless otherwise indicated.

- H. Electromagnetic-Interference Filters: Factory installed to suppress conducted electromagnetic-interference as required by MIL-STD-461E. Fabricate lighting fixtures with one filter on each ballast indicated to require a filter.
- I. Air-Handling Fluorescent Fixtures: For use with plenum ceiling for air return and heat extraction and for attaching an air-diffuser-boot assembly specified in Division 23 Section "Diffusers, Registers, and Grilles."
 - 1. Air Supply Units: Slots in one or both side trims join with air-diffuser-boot assemblies.
 - 2. Heat Removal Units: Air path leads through lamp cavity.
 - 3. Combination Heat Removal and Air Supply Unit: Heat is removed through lamp cavity at both ends of the fixture door with air supply same as for air supply units.
 - 4. Dampers: Operable from outside fixture for control of return-air volume.
 - 5. Static Fixture: Air supply slots are blanked off, and fixture appearance matches active units.

2.3 LED LUMINAIRES AND DRIVERS

- A. All Luminaires
 - 1. Comply with IES LM-79-08 Approved Method for measuring lumen maintenance of LED light sources.
 - 2. Comply with IES LM-80-08 Approved Method for electrical and photometric measurement of SSL product.
 - 3. Comply with In-Situ testing for more reliable results.
 - 4. LED's shall be Restriction of Hazardous Substances Directive (RoHS) compliant.
 - 5. LED arrays shall be sealed, high performance, long life type; minimum 70% rated output at 50,000 hours.
 - 6. LED luminaires shall deliver a minimum of 60 lumens per watt.
 - a. LED's shall be "Bin No. 1" quality
 - 7. Drivers shall be solid state and accept 120 through 277 VAC at 60 Hz input.
 - 8. The LED light source shall be fully dimmable with use of compatible dimmers switch designated for low voltage loads.
 - 9. LED color temperatures: CRI> 85, 2700K as noted +/- 145K.
 - 10. LED color temperatures: CRI> 85, 4000K as noted +/- 275K.
 - 11. LED color temperatures: CRI> 85, 5000K as noted +/- 283K.
 - 12. Luminaires shall have internal thermal protection.
 - 13. Luminaires shall not draw power in the off state. Luminaires with integral occupancy, motion, photo-controls, or individually addressable luminaires with external control and intelligence are exempt from this requirement. The power draw for such luminaires shall not exceed 0.5 watts when in the off state.
 - 14. Color spatial uniformity shall be within .004 of CIE 1976 diagram.
 - 15. Color maintenance over rated life shall be within .007 of CIE 1976.
 - 16. Indoor luminaires shall have a minimum CRI of 85.
 - 17. Luminaire manufacturers shall adhere to device manufacturer guidelines, certification programs, and test procedures for thermal management
 - 18. LED package(s)/module(s)/array(s) used in qualified luminaires shall deliver a minimum 70% of initial lumens, when installed in-situ, for a minimum of 50,000 hours.
 - 19. Luminaires shall be fully accessible from below ceiling plane for changing drivers, power supplies and arrays.

- B. Power Supplies and Drivers
 1. Power Factor: 0.90 or higher
 2. Maximum driver case temperature not to exceed driver manufacturer recommended insitu operation.
 3. Output operating frequency: 60Hz.
 4. Interference: EMI and RFI compliant with FCC 47 CFR Part 15.
 5. Total Harmonic Distortion Rating: 20% Maximum.
 6. Meet electrical and thermal conditions as described in LM-80 Section 5.0.
 7. Primary Current: Confirm primary current with Drawings.
 8. Secondary Current: Confirm secondary current specified by individual luminaire manufacturers.
 9. Compatibility: Certified by manufacturer for use with individually specified luminaire and individually specified control components.
 10. Solid-state control components to be integral or external per each specified luminaire. Remote control gear to be enclosed in Class 1, Class 2, or NEMA 3R enclosures as required.
- C. Controller and Control System
 1. System electronics driver / controller to use coordinated communication protocols: 0-10V, or proprietary as required
 2. The Contractor to ensure that external control equipment is compatible with LED control requirements
 3. Provide connector types and wiring as appropriate for un-interrupted communication between devices, considering distance maximums, field obstructions, and accessibility. Ensure that connection points are optically isolated for system noise reduction.
 4. For control components that are part of overall area control system see Dimming

2.4 EXIT SIGNS

- A. Description: Comply with UL 924; for sign colors, visibility, luminance, and lettering size, comply with authorities having jurisdiction.
- B. Internally Lighted Signs:
 1. Lamps for AC Operation: LEDs, 70,000 hours minimum rated lamp life.

2.5 LIGHTING FIXTURE SUPPORT COMPONENTS

- A. Comply with Division 26 Section "Hangers and Supports for Electrical Systems" for channel- and angle-iron supports and nonmetallic channel and angle supports.
- B. Single-Stem Hangers: 1/2-inch steel tubing with swivel ball fittings and ceiling canopy. Finish same as fixture.
- C. Twin-Stem Hangers: Two, 1/2-inch steel tubes with single canopy designed to mount a single fixture. Finish same as fixture.
- D. Wires: ASTM A 641/A 641M, Class 3, soft temper, zinc-coated steel, 12 gage.
- E. Wires for Humid Spaces: ASTM A 580/A 580M, Composition 302 or 304, annealed stainless steel, 12 gage.
- F. Rod Hangers: 3/16-inch minimum diameter, cadmium-plated, threaded steel rod.

- G. Hook Hangers: Integrated assembly matched to fixture and line voltage and equipped with threaded attachment, cord, and locking-type plug.

PART 3 - EXECUTION

3.1 INSTALLATION

- A. Lighting fixtures: Set level, plumb, and square with ceilings and walls. Install lamps in each fixture.
- B. Support for Lighting Fixtures in or on Grid-Type Suspended Ceilings: Use grid as a support element.
 - 1. Install a minimum of four ceiling support system rods or wires for each fixture. Locate not more than 6 inches from lighting fixture corners.
 - 2. Support Clips: Fasten to lighting fixtures and to ceiling grid members at or near each fixture corner with clips that are UL listed for the application.
 - 3. Fixtures of Sizes Less Than Ceiling Grid: Install as indicated on reflected ceiling plans or center in acoustical panel, and support fixtures independently with at least two 3/4-inch metal channels spanning and secured to ceiling tees.
 - 4. Install at least one independent support rod or wire from structure to a tab on lighting fixture. Wire or rod shall have breaking strength of the weight of fixture at a safety factor of 3.
- C. Suspended Lighting Fixture Support:
 - 1. Pendants and Rods: Where longer than 48 inches, brace to limit swinging.
 - 2. Stem-Mounted, Single-Unit Fixtures: Suspend with twin-stem hangers.
 - 3. Continuous Rows: Use tubing or stem for wiring at one point and tubing or rod for suspension for each unit length of fixture chassis, including one at each end.
- D. Air-Handling Lighting Fixtures: Install with dampers closed and ready for adjustment.
- E. Adjust aimable lighting fixtures to provide required light intensities.
- F. Connect wiring according to Division 26 Section "Low-Voltage Electrical Power Conductors and Cables."

3.2 FIELD QUALITY CONTROL

- A. Test for Emergency Lighting: Interrupt power supply to demonstrate proper operation. Verify transfer from normal power to emergency and retransfer to normal.
- B. Prepare a written report of tests, inspections, observations, and verifications indicating and interpreting results. If adjustments are made to lighting system, retest to demonstrate compliance with standards.

END OF SECTION

This page is intentionally left blank.

MaineHealth

Network Engineering

Infrastructure Specifications

CSI Master Format Division 27

[Revised Date: May 2017](#)

295 Park Avenue
Portland, Maine 04101

Table of Contents

PART 1 – GENERAL

<u>1.1 Summary</u>	4
<u>1.2 Related Documents</u>	5
<u>1.3 Submittals</u>	5
<u>1.4 Revisions</u>	6
<u>1.5 Definitions</u>	6

PART 2 - PRODUCTS

<u>2.1 Approved Sources</u>	6
<u>2.2 Approved Products</u>	6
<u>2.3 Product Condition and Warrantees</u>	6
<u>2.4 Product Handling, Storage and Delivery</u>	7

PART 3 – EXECUTION

<u>3.1 General Contractor Installation Responsibilities</u>	7
<u>3.2 Common Work Results</u>	9
<u>3.3 Special Work Results – Legacy Voice Installations</u>	9
<u>3.4 Special Work Results – CATV Systems</u>	10
<u>3.5 Special Work Results – Overhead Paging</u>	10
<u>3.6 Special Work Results- Nurse/Patient Call Systems</u>	10
<u>3.7 Optical Fiber Cabling</u>	10
<u>3.8 Commissioning and Testing</u>	11
<u>3.9 Documentation</u>	12
<u>3.10 Appendix Index</u>	13

APPENDIX INDEX

Appendix A - Low Voltage Cabling Approved Products 14
Appendix B - Video Systems Approved Products 17
Appendix C - Nurse Call Systems Approved Products 18
Appendix D - Approved Cabling Contractors 26
Appendix E - Preferred Vendor List - Misc. Systems 27
Appendix F - Telecommunications Room Layout 28
Appendix G - Work Area Outlet Standard Configurations 29
Appendix H - Documentation Legend 32
Appendix I - Terminations Samples 33
Appendix J - Grounding and Bonding 35
Appendix K - Primary Protection 39
Appendix L - Fire Stopping 40
Appendix M – Contractor/GC Assumptions 45
Appendix N – Overhead Paging 48

DRAFT

SECTION 27 00 00 – COMMUNICATIONS - STRUCTURED CABLING

PART 1 – GENERAL**1.1 SUMMARY**

- A. This document defines the Communications Infrastructure requirements for Voice, Data (Network), CATV, Video, Paging (Public Address) and Nurse Call Systems.
- B. This document, titled "Network Engineering Infrastructure Specifications" may be incorporated by reference or attachment in construction and/or project specific documents and will be the governing requirements for approved products, installation practices, testing, acceptance and operating criteria as it relates to the Information Technology (IT) Infrastructure of all MaineHealth (MH) Facilities.
- C. The current version of the document will be indicated on the cover page with the revision date clearly noted.
- D. All previous versions of this document including but not limited to those titled "Telecommunications Network Services 16600 Specifications" and "Maine Medical Center D27 Version 4" dated November 2013 are obsolete and shall not be used.
- E. These standards have been developed and implemented to ensure that all MH facilities have a consistent and reliable infrastructure in place that can be properly maintained, operated and serviced.
- F. All work results shall produce a complete and functional system which meets the performance criteria defined within this document and all referenced external documentation.
- G. Maine Health uses the Ortronics Open Systems Architecture and the Corning Cable Systems LANscape NPI manufacturer performance warrantee Systems; the applicable system(s) will be specified within the scope of work documents on a per project basis.
- H. All Voice, Data, CATV and Optical Fiber Cabling and Components shall be installed by a MH approved cable installation firm as referenced in [Appendix B](#) of this document.
- I. Any request for changes or deviations from these specifications must be made in writing to the designated MH project manager and must be approved by MH Network Engineering prior to any work being performed.

1.2 RELATED DOCUMENTS

- J. Drawings and general provisions of the contract, including general and supplementary conditions and other CSI specification sections apply to work within this section.
- K. Unless specifically indicated otherwise, all referenced documents shall be the most current version as accepted by any and all Authorities having Jurisdiction (AHJ)
- L. Specifications for approved products are incorporated by reference.
- M. External Codes, Standards and Ordinances are also referenced throughout this document, where no version is indicated; the most current version should be utilized.

1.3 SUBMITTALS

- N. No substitution of material or equipment for that specified on the project documents will be allowed without prior approval in writing from an authorized MH Network Engineering representative.
- O. No shop drawings shall be submitted for materials on the approved list in appendix A unless required by project specifications.
- P. Where submittals are required, the procedure will be as follows:
 - a. Submittals shall be in Electronic, Portable Document Format (PDF) and provided to the designated primary MH Network Engineering contact for the project.
 - b. Submittals shall contain reference to manufacturer name and specific part number(s) including performance specific information and specifications as required to meet the MH requirements.
 - c. Submittals shall include a schedule/index which lists the delivery lead times in calendar days between the time an order is placed with the distributor and the time it can be delivered to the work site. No proposed item will be reviewed without its delivery lead-time indicated.
- Q. In the event a manufacturer has made changes to a part number previously approved and/or specified (new # supersedes an existing # etc) the new number shall be provided with the old number noted as a reference and presented as a submittal for approval prior to use.
- R. When printed drawings are required, they will be in ANSI Size "D" (22 x 34") unless otherwise specified.

1.4 REVISIONS

- S. This document is a major revision to the previous specification document titled “Network Engineering Infrastructure Specifications” dated November 2013, it obsoletes and replaces any and all previous versions.
- T. No handwritten or otherwise modified versions of this document are permitted for any reason.
- U. Requests for changes, updates or revisions should be made in writing to the MaineHealth Manager of Network Engineering, clearly stating the reason for the request and the specific area(s) of the document involved.

1.5 DEFINITIONS

- ADA:** Americans with Disabilities Act (ada.gov)
- BICSI:** Building Industry Consulting Service International (bicsi.org)
- CATV:** Cable Television
- GCM:** Global Control Module
- MH:** MaineHealth (www.mainehealth.org)
- NEC:** National Electrical Code (www.nfpa.org)
- NFPA:** National Fire Protection Association (www.nfpa.org)
- TIA:** Telecommunications Industry Association (www.tiaonline.org)
- TR:** Telecommunications Room
- UL:** Underwriters Laboratories (<http://ul.com>)
- WAO:** Work Area Outlet

PART 2 – PRODUCTS

2.1 Approved Sources

- A. Products shall be purchased only through authorized manufacturers distribution channels that have an ISO registered quality system in place to ensure identification, traceability and product warrantee coverage.

2.2 Approved Products

- B. [Appendix A](#) contained within this document lists the MH approved system components and products to be used.
- C. Where an item is required that is not listed, a formal request for approval as a “one time” use item shall be made in writing to the Network Engineering department and must include product specifications, reason for use and intended source of supply.

2.3 Product Condition and Warrantees

- D. All products shall be new and of current design.

- E. The use of used, reconditioned, “gray market” or obsolete products is strictly forbidden.
- F. Cabling installations shall be covered by a manufacturers system performance warrantee in addition to the standard product warrantee. (see also 1.1-H)

2.4 Product Handling, Storage and Delivery

- G. Storage space at MH is at a premium at all times. Contractors should take note of this and make arrangements for delivery of project materials according to project time lines.
- H. Materials shall be kept clean, dry and protected at all times against exposure to weather, adverse environmental conditions and contact with damp or wet surfaces
- I. Products supplied to MH as spares or on-hand inventory shall be in the original manufacturers packaging and clearly labeled with Part Number and Project Name and where applicable, the system and/or service they are supporting.

PART 3 – EXECUTION

3.1 General Contractor Installation Responsibilities - 27 05 00

- A. A Network Engineering Specification review meeting will be held prior to any work commencing on any MH project.
- B. Contract documents shall contain methods and procedures for labeling and documentation of all terminations in conjunction with the MH defined ID schemes in this document.
- C. Contractors shall submit a detailed description showing methods and procedures for labeling; testing and documenting installed cabling including the test equipment to be utilized and the credentials of the person(s) performing the testing.
- D. Contractors shall have a designated project manager or single point of contact for all work sites at all times.
- E. Location and installation of cables shall be accomplished according to the Project Master Floor/Site Plan.
- F. The contractor shall perform all terminations at the origination (TR) and work area outlet (WAO) ends of installed cables.
- G. The contractor shall supply all cable, connecting hardware and terminating equipment in compliance with the MH approved materials lists contained in this document and/or any project specific requirements.
- H. All diagrams depicting rack layouts, patch panel locations, room layouts and backboard plans shall be followed exactly as detailed. No deviations from

these plans shall be acceptable without the prior written approval of MH Network Engineering.

- I. All Riser cabling shall be run in a designated pathway/conduit and the Pathways will be sized based on the TIA-569 standard using applicable fill capacity tables.
- J. Riser cables will be terminated and labeled according to the TIA standards using the MH specified Identifiers, including cable number, origination and destination locations as detailed in the contract documents for the project.
- K. Grounding and Bonding of Pathways, Spaces and Cables shall comply with any and all NEC, TIA and BICSI Codes and Standards in conjunction with the appendix contained in this document.
- L. All cables, work area outlets and connecting hardware will be labeled according to the MH designated identification scheme using machine generated, permanent labels per TIA-606.
- M. Any cables terminated above ceilings shall be housed in a standard single-gang surface mount workbox or other MH approved device that is properly affixed to walls or other suitable solid building structures.
- N. All cables will be bundled neatly, wrapped with hook and loop type fasteners and dressed into the terminating panels.
- O. Origination and Station (WAO) locations shall be identified using the MH designated identifiers on the Master Floor Plans for the project and detailed within the Scope of Work document(s).
- P. Contractors are responsible for obtaining all necessary permits, approvals and complying with all applicable Codes, Regulations, Ordinances and Standards.
- Q. All Infection Control Methods and Procedures shall be followed during any Network Engineering related work performed in any MH facility. The Infection Control Risk Assessment (ICRA) survey process must be completed for all MH facilities prior to the commencement of any work. A copy of the Infection Control Procedures shall be provided to the contractor prior to any work being done. Detailed instructions on this process are part of the Contractor Orientation training.
- R. Fire Stopping is an integral requirement of any work performed at any MH facility as in covered in detail within the appendix of the document.
- S. Contractors are required to complete Mandatory Contractor Orientation Training prior to installing any fire stop system or component in any MH Facility.
- T. Badge Access is required to be installed as part of any new construction or major renovation of a Telecommunications or Network Room.

- U. Fiber terminations will be done using Corning splice on connectors. No other termination types will be allowed without prior approval by MH Network Engineering.
- V. Maxcell Fabric Innerduct will be used in all conduit installations. No other product is to be used without prior approval from MH Network Engineering.

3.2 Common Work Results – 27 05 00

- A. Plenum rated cable shall be used for all cabling installations.
- B. MH's cabling pin-pair terminating standard is T568-A at some locations and T568-B in others (for example, MMC is T568-A) This will be further defined with an individual scope of work per project per location.
- C. Service loops for cabling shall be 5 ft and within industry guidelines, including bend radius and separation.
- D. Cabling shall use and be placed into designated pathways only with no weaving or passing through adjacent piping, conduits or building elements.
- E. Cable in Ladder trays shall be placed to avoid coiling or looping.
- F. Directional changes shall be made with sweeping 90 degree angular turns in compliance with bend radius and installation requirements as defined in the BICSI Information Technology Systems Installation Methods Manual (ITSIMM) and the NECA/BICSI-568 Standard for Installing Commercial Building Telecommunications Cabling.
- G. When using existing pathways, any old cable ties shall be removed, properly disposed of and replaced with Hook and Loop type fasteners of the appropriate rating.
- H. Any abandoned cabling shall be removed and disposed of in compliance with any NEC NFPA-70 Electrical Code and applicable Environmental regulations.
- I. Standard Patch Panel Size will be 48 Port panels unless otherwise approved by MH Network Engineering in conformance with the approved materials list in Appendix A.
- J. Sleeve size shall be determined by Scope of work document or other contract specific documents.

3.3 Special Work Results – Legacy Voice Installations - 27 15 00.16

- A. Legacy Voice installations utilize a non-standard termination method consisting of splitting a 4-Pair UTP cable into two (2) each 2 pair terminations using a Single RJ-45-TI500 Track Jack Module as defined in the approved materials list.
- B. Legacy Voice cabling shall be terminated at the Administration End (origination point) (TR) on hardware specified in SOW or work order.
- C. These legacy voice terminations will be tested using the "Voice-2 Pair" test set parameters listed in the certification test set parameters under application

specific tests using the Category 6A UTP Cable Types and the T568A Outlet Configuration.

- D. In transitional environments supporting (As determined by MH Network Engineering) Analog or Digital stations such as with new Horizontal Cable/Old Riser, Multi-Pair UTP Cable (Category 3 or 5e) will be run between the BIX field and the Racks. Horizontal Cabling will terminate on 24 or 48 Port Category 6 Patch Panels as detailed in 3.2-I.

3.4 Special Work Results – CATV Systems - 27 41 00.33

- A. All materials shall conform to the approved materials list.
- B. All cables shall be home runs. Splitting, tapping or splicing outside the TR is not permitted unless specified in project specific documentation for special situations or applications.
- C. All Coaxial Cable connectors shall be of the compression type. The use of twist-on or crimp (hex) type connectors is forbidden.
- D. All Connections shall be contained in a single gang workbox.

3.5 Special Work Results – Overhead Paging

- A. Overhead paging systems vary throughout the MaineHealth System. Please see Appendix N for Site specific paging requirements.

3.6 Special Results- Nurse/Patient Call Systems -27 52 00

- A. Due to the fact that there are several different Nurse Call system types and Manufacturers used across MaineHealth this section will be covered in detail per member hospital in Appendix C.

3.7 Optical Fiber Cabling – 27 13 23

- A. All cable, connectors, and hardware shall comply with the approved materials list.
- B. Fiber Performance Grade, Type, Jacket, and Fiber Count will be specified on a per project basis as defined in the scope of work.
- C. All Cables will be Plenum Rated
- D. Backbone Riser Cables will be installed within Conduit or will be of Armored Construction and will be specified in the contract documents.
- E. The standard Connector Type for all New Installations of Optical Fiber Terminations is the Type LC connector as listed in the [approved materials list](#) in this document unless otherwise specified in a project SOW and approved by MH Network Engineering.
- F. When armored fiber is utilized, it shall be bonded if the cable armor is metallic. The armor shall enter and be secured within the enclosure.
- G. All fibers of installed cables shall be terminated and tested regardless of any fibers designation for future use or spares.

- H. Fiber shall be terminated according to the TIA color code and polarity standards. All future fiber connectors will be Factory Polished Fusion Spliced.
- I. All installed and Connectorized (terminated) fibers shall be covered with an appropriate dust cover made by the manufacturer of the hardware to prevent contamination and ensure the integrity of the connector end-face.
- J. All optical fiber cables must be labeled with Fiber Optic warning tags within 18" of entering any enclosure (Fiber Patch Panel or Light guide Interface Unit (LIU)) as well as on either side of any penetration. Identification tags will also be placed every 50 ft. throughout the fiber run. These tags must show the fiber type, fiber count, construction and source and destination locations. This information shall also be included on each enclosure and corresponding test reports.

3.8 Commissioning and Testing - 27 08 00

- A. Voice and Data Copper (UTP) Cables will be tested using an industry standard certification test set of level III or higher accuracy using the current TIA Test Limits to the Category 6A Permanent Link parameters.
- B. Test results shall use the MH designated identifiers for each cable, 100% Testing of all installed cabling is required.
- C. MH reserves the right to perform random testing of installed cabling prior to acceptance of final contractor results.
- D. Any cable that does not pass the certification test must be re-terminated or replaced at the contractor's expense. Conditional Pass results (indicated by an asterisk) are not acceptable.
- E. Optical Fiber Cable will be tested to the TIA-568-C test parameters using an industry standard certification test set with the appropriate Light Source and Power meter as defined by TIA TSB-140 for Tier 1 Testing.
- F. Multi-Mode Optical fiber will be tested at both the 850nm and 1300 nm wavelengths bi-directionally.
- G. Single-Mode Optical fiber will be tested at both the 1310nm and 1550nm wavelengths bi-directionally.
- H. Test results must include the specified MH Identifiers and the number of connectors and/or splices as applicable with the db loss in each direction at each of the specified wavelengths.
- I. Any Fiber not passing the testing must be repaired or replaced at the contractor's expense.
- J. Tier 2 Testing (Characterization-OTDR) may be requested on a project specific basis and will be performed as stated in TIA TSB-140 for the type of fiber being tested.
- K. Test Results will be provided to MH Network Engineering in Portable Document Format (PDF) in email, or on Disk showing the Date, Project Name

and Location with a testing summary and then each test result on its own page, clearly stating the MH identification number and the test results for each cable.

3.9 Documentation

- L. Contractors shall provide a complete set of as-built drawings to MH prior to acceptance with the as-built indicating all types and sizes of facility pathways, junctions and termination points.
- M. As-Built drawings shall be provided electronically in .DWG format and printed on "D" size paper when requested, 2 copies of each sheet and are to be in three layers as follows:
 1. Voice/Data including pathways
 2. Paging/Coax including Tap Locations
 3. Nurse Call to include all cabling paths and locations.

DRAFT

3.10. APPENDIX INDEX

Appendix A	-	Approved Products List
Appendix B	-	Video Systems Products
Appendix C	-	Nurse Call Systems and Specifications
Appendix D	-	Approved Low Voltage Contractors
Appendix E	-	MH Preferred Vendor List (Miscellaneous)
Appendix F	-	Telecommunications Room (TR) Layouts
Appendix G	-	Work Area Outlet Standard Configurations
Appendix H	-	Telecommunications Legend (Master Floor Plan)
Appendix I	-	Telecommunications Room Terminations
Appendix J	-	Grounding and Bonding Details
Appendix K	-	Primary Protection of Communication Systems
Appendix L	-	MH Firestopping Requirements
Appendix M	-	General Contractor Assumptions List
Appendix N	-	MH OverHead Paging Systems and Specifications

Appendix A

Approved Products List

Product Number	Product Description
55053-703	(Primary) Chatsworth 19" Universal Rack (Black)
55053-503	Chatsworth 19" Universal Rack (Clear)
11729-703	(Primary) Chatsworth Vertical Section 6"(Black)
11729-503	Chatsworth Vertical Section 6"(Clear)
12096-703	Chatsworth Vertical Section 3"(Black)
12096-503	Chatsworth Vertical Section 3"(Clear)
10250-712	12"Universal Cable Runway (Black)
10250-718	18"Universal Cable Runway (Black)
10250-724	24"Universal Cable Runway (Black)
OR-PHD66U24	Ortronics Category 6 24 port Patch Panel (Transitional Environment)
OR-PHD66U48	Ortronics Category 6 48 port Patch Panel (Transitional Environment)
OR-TJ5E00	Clarity 5E TracJack Fog White (Transitional Environment)
OR-40300656	Series II Angled Bezel Fog White (Transitional Environment)
OR-40300144	Series II Blank Module .5 Fog White (Transitional Environment)
OR-PHD6AU48	(Primary) Clarity 6A/10G 48 Port Patch Panel 2U
OR-PHD6AU24	Clarity 6A/10G 24 Port Patch Panel 1U
OR-401045292	Standard Density 48 port TracJack Patch Panel 3U
OR-401045290	Standard Density 24 port TracJack Patch Panel 2U
OR-60400426	(Primary) Ortronics Cable Management Panel 2U
OR-60400129	Ortronics Cable Management Panel 1U
OR-60400199	Ortronics Bend Limiting Strain Relief Bar
OR-TJ6A	(Primary) Clarity 6A/10G Category 6A TracJack Fog White
OR-40300545	(Primary) Single Gang Faceplate Holds (6) TracJack Fog White
OR-40300555	Double Gang Faceplate Holds (6) TracJack Fog White
OR-42100002	TracJack Blanks (package of 10)
OR-63700006	TracJack F Conn 75 ohm Female to Female
OR-40300577-00	Furniture Plate Herman Miller 2.35" x 3.41" Black
OR-40300633-00	Furniture Plate 2.75" x 1.41" Black
OR-40700073-00	Furniture Plate 2.71" x 1.38" Black
OR-404TJ2	Surface Housing for TracJack
OR-403STJ1WP	Single Gang Stainless TracJack Faceplate w/Phone Studs (IP set)
AT630B-8	Single Gang Stainless 8p8c Faceplate w/Phone Studs (TDM set)
CABLOFIL	CABLOFIL Cable Tray Management System (sized per project)
CADDY CAT HP	Caddy CAT HP J-Hook system (sized per project)
WIREMOLD 2000	2000 Series Raceway, Fittings, Boxes Ivory
WIREMOLD 700	700 Series Raceway, Fittings, Boxes Ivory
LD3IW6-A	Panduit Latching Duct Surface Raceway LD3 Type
LD5IW6-A	Panduit Latching Duct Surface Raceway LD5 Type

Appendix A (Continued)

BIX Type Connections:

<u>Belden Number</u>	<u>Product Description</u>
A0270164	QMBIX10A 250 pair distribution frame
A0340836	QMBIX12E 300-pair distribution frame
A0266828	QMBIX1A5 25-pair distribution connector (5pr)
A0393146	QMBIX1A4 25-pair distribution connector (4pr)
A0270169	QMBIX20A Data plate
A0270168	QMBIX19A Distribution ring
P0748006	QCBIX1A4 Label, Blue
P0588406	QCBIX1A Label, White
P0748019	QCBIX1A Label, Grey

Station (Horizontal) Cable – Voice, Data and Valcom Paging

<u>Product Number</u>	<u>Description</u>
11082057	Berktek 4 Pair Category 6A Blue (Plenum)

Nurse Call Cable – Rauland 4000

<u>Product Number</u>	<u>Description</u>
10034514	Berktek 4 Pair Category 5E Black (Plenum)

Riser (Backbone) Cable - Copper

The following manufacturers provide an acceptable Multi-Pair Riser cable product for use throughout the MMC system. Each manufacturer noted below may provide any of the multi-pair cables noted in the description field below. Prior to any installations, all vendors shall provide MMC Network Engineering with the complete Manufacturers specifications for the intended product.

Approved Manufacturers

Ortronics
 Berk-Tek
 General Cable
 Superior-Essex
 Mohawk

Appendix A (Continued)

Fiber Optic Cable and Hardware

Confirmation of Materials to be used is required (also see 1.3 – R). All products chosen from links below need to be approved by MH Network Engineering prior to installation.

Corning Cable Systems

MIC DX Tight Buffer Plenum

http://csmedia.corning.com/CableSystems//Resource_Documents/product_family_specifications_rl/MIC_DX_Tight_Buffered_Armored_Cable_Riser_NAFTA_AEN.pdf

MIC Interlocking Armored Tight Buffer Plenum

http://csmedia.corning.com/opcomm/Resource_Documents/product_family_specifications_rl/MIC_TB_Interlocking_Armored_Plenum_Cables_2_24_Fibers_NAFTA_AEN.pdf

Closet Connector Housings (CCH)

http://catalog.corning.com/CableSystems/en-US/catalog/MasterProduct.aspx?cid=CCH_housings_web&pid=77702&rot=fiber_optic_hardware_web

Wall-Mounted Connector Housings (WCH)

http://csmedia.corning.com/CableSystems//Resource_Documents/product_family_specifications_rl/LAN-137-EN.pdf

Connector Panels

http://catalog.corning.com/CableSystems/en-US/catalog/CategoryBrowser.aspx?cid=CCH_panels_web&rot=fiber_optic_hardware_web

Pigttailed Splice Cassettes

http://catalog.corning.com/opcomm/en-US/catalog/MasterProduct.aspx?cid=CCH_cassettes_web&pid=95363&rot=fiber_optic_hardware;

Splice-On Connectors

http://csmedia.corning.com/opcomm/Resource_Documents/product_family_specifications_rl/FuseLite_Single_Fiber_Splice_On_Connectors_NAFTA_AEN.pdf

Pretium Edge HD Solutions

http://csmedia.corning.com/CableSystems//Resource_Documents/product_family_specifications_rl/premium_EDGE_HD_solutions_NAFTA_AEN.pdf

Pretium EDGE FX Solutions

http://csmedia.corning.com/CableSystems//Resource_Documents/product_family_specifications_rl/Pretium_EDGE_FX_Solutions_NAFTA_AEN.pdf

Additional Requirements:

Regardless of the Corning Cable Systems Product Family used, all Glass used in the Cabled assemblies shall be Corning Glass only and of the Performance Grade specified (OM3, OM4, OS2).

Appendix B

CATV Systems Approved Products List

1. Coaxial cable used in MH locations shall be Commscope, Times Fiber or Belden brand and shall be white in color, plenum rated and quad shielded.
2. All jumpers will be plenum-rated RG-6 or RG-11 with compression fitting made by any manufacturer or onsite.
3. All connectors shall be compression type that specifically matches the cable being used.
4. Faceplates and RF related inserts unless otherwise specified shall be Ortronics brand (see Appendix A)

<u>MFG.</u>	<u>Part #</u>	<u>Description</u>
BT	CRT-(*)	One Port Tap/Directional Coupler
BT	SXRS-2 or SCVS-2	2 Way Splitter
BT	SXRS-4 or SCVS-4	4 Way Splitter
BT	SXRS-8 or SCVS-8	8 Way Splitter
BT	F81	F-F Splice Female/Female Barrel
BT	F-59T	75 Ohm Terminator
BT	FAM-(*)	Assorted Attenuator
BT	BITA 550-50	Distribution Amp
BT	BITA-RF	Return Filter
BT	BITA-RA	Return Amp
BT	BITA-CE-4	Cable Equalizer
BT	BITA-FA-(*)	Amplifier Attenuator
HA	MCO1/4-F	TV Outlet w/Control Cable Jack (No cover Plate)
HA	JK1/4-PLT	Pillow Speaker Jack w/Single Gang St. Steel Plate
HA	WP-81SS	Stainless Steel Face Plate With "F" Barrel
HA	WP-81IV	Ivory Face Plate w/"F" Barrel

BT=Blonder Tongue

HA=Howlands Associates

Note: All above-mentioned components available from Howlands Associates.

Prior to any installations, all vendors shall provide MH Network Engineering with the complete Manufacturers specifications for the intended product.

Appendix C

Nurse Call Systems and Specifications

By MaineHealth Member

MMC

Special Results- Nurse/Patient Call Systems -27 52 00

- A. Two types of Nurse-Patient Call Systems are in use at MMC, a Visual/Voice System (Rauland-Borg Responder IV and V) and a Visual Only System (The Rauland-Borg Responder 4000) Common requirements and specifications are listed first and then system specific information will follow. Due to the proprietary and critical nature of these systems, special care should be given to understanding the infrastructure requirements in addition to programming and communications protocols.
- B. System design shall be performed only by factory certified personnel and must be reviewed and approved by MMC Telecommunications personnel prior to installation.
- C. Installation and programming shall be performed only by factory certified personnel according to all current manufacturer standards and recommendations unless specified by MMC Telecommunications.
- D. Installation of nurse call systems shall only be performed by technicians holding a valid State of Maine Low Energy license or working with a helpers license under the direct supervision of a Master Electrician or licensed Low Energy Electrician.
- E. All installations of Rauland nurse call systems will be performed in strict accordance with Rauland specifications for the respective system(s) with particular attention being paid to power calculations and CGM interconnects unless otherwise specified by MMC. All installations of nurse call station components (i.e. call stations, dome lights, duty/staff stations) must be performed in strict accordance with System Owner specifications.
- F. All part numbers for components and/or hardware required for the Nurse Call systems shall be identified by utilizing the appropriate Rauland installation manual.
- G. All Nurse call system cabling and components shall be UL listed and installed according to NFPA 70 with all cabling tested for continuity and free from shorts and faults.
- H. All Nurse Call systems installed at MMC shall be connected to Hospital Emergency Power.
- I. For non-integrated pillow speaker installations, the cabling shall consist of Plenum rated, stranded 3-wire 18 gauge cable. The black, red and white

wires in the cable shall be terminated by the contractor on a standard stainless steel faceplate located on the headwall. The faceplate will contain a 1/4" jack supplied by the contractor. The jack behind the TV will contain a coaxial "F" type connector and a 1/4" jack. (See also standard faceplate configurations in the appendix of this document)

- J. For integrated Pillow Speaker installations, the faceplate will be of Stainless Steel and contain only a 1/4" hole for the cable to pass through with final connections being performed by the nurse call system installer.
- K. If requested as part of the project SOW the contractor will provide thorough in-service training of all nursing staff assigned to applicable nursing units unless otherwise specified in contract documents will provide in-service training.
- L. K. If requested as part of the project SOW the training provided the nursing staff is to enable them to fully understand the operation of the system in order to provide adequate patient support respective to the process used on their floors. A separate training room shall be set up that allows this type of individualized training utilizing an in-service training unit, prior to the cut over of the new system.

Visual/Voice Nurse Call Systems (Rauland-Borg Responder IV)

- M. Rauland Responder IV Nurse Call Systems shall be installed where a visual/voice nurse/patient call system is required. This system provides two-way communications from a patient room to the nurse station as well as visual and/or audible annunciation at a variety of other devices such as corridor lamps and duty stations.
- N. Under no circumstances will any programming of the nurse call systems at MMC be performed without prior review and approval from the Telecommunications department at MMC. All programming performed on the Rauland systems at MMC must be accompanied by a MMC work order describing the type of programming needed. For major changes to the system, all programming must be documented using the process described below and accompanied by factory programming forms. The forms are contained in Appendix A of the Rauland Responder IV Applications Manual, Section K11970A.

Visual Only Nurse Call Systems (Rauland-Borg Responder 4000)

- O. The Rauland-Borg Responder 4000 Nurse/Patient Call System shall be installed where a visual only nurse/patient call system is required
- P. The Responder 4000 system utilizes Black, Category 5e, Plenum Rated UTP Cable as listed in the MMC approved materials list.

TYPICAL RESPONDER 5 NURSE CALL LAYOUT - PATIENT ROOMS

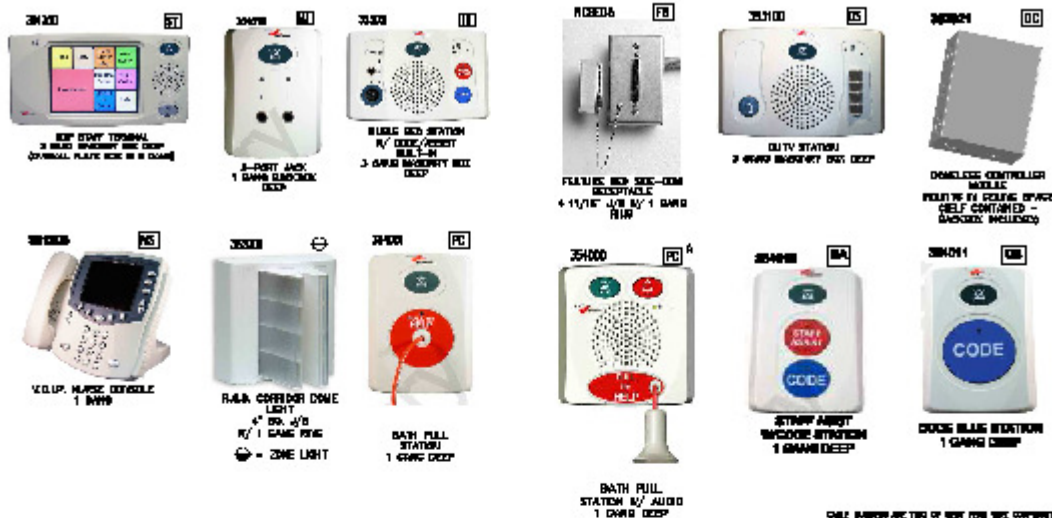

CHIEF ENGINEER APPROVAL OF THIS SPEC. AND THE CONTRACTOR (PLEASE SIGN AND DATE)

CABLE LEGEND		
LETTER	CABLE DESCRIPTION	R.P. NUMBER
E	2 CONDUCTOR, 14 AWG, CABLE	25000
J	4 PAIR OF 26, ETP, 24 AWG	25000
N	4 CONDUCTOR, 22 AWG, STRANDED	25241
Q	1 CONDUCTOR, 14 AWG, 48% TANN	25000
	UNIDENTIFIED CABLES, SPECIFIED BY CONTRACTOR	

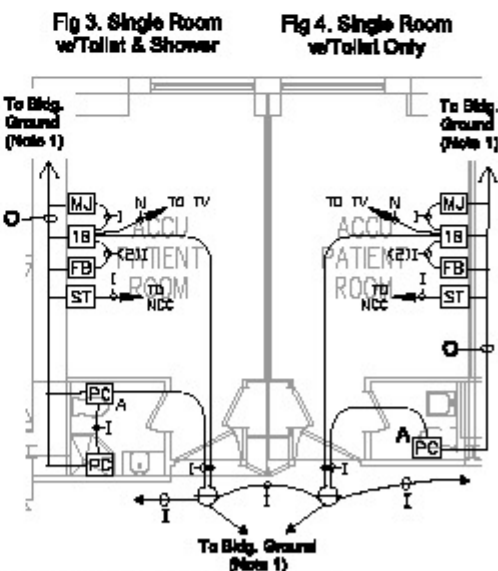
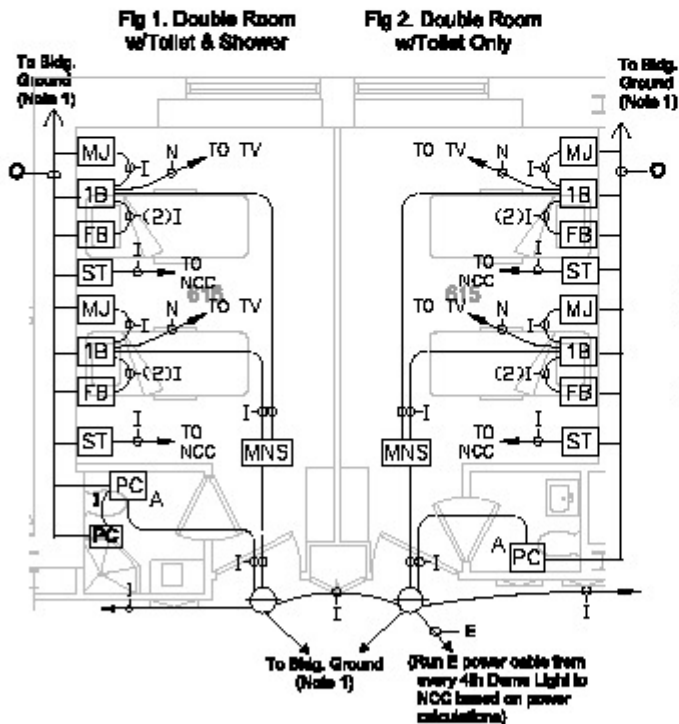

- Notes:**
1. Responder 5 devices must be connected to a grounded metal electrical box to prevent electrostatic discharge and help eliminate any RF noise interference being introduced into the Nurse Call system. In those installations, whereby the ground is not available due to the design of the building frame, a 14 AWG wire must be run to each electrical back box location and secured on the other end to a building earth ground (i.e. ceiling metallic grid, metal pipe, etc.).
 2. Cable Run for VoIP Staff Terminal (ST) to not exceed 300'.

TYPICAL RESPONDER 5 NURSE CALL LAYOUT - VoIP CONSOLE, COMMON ROOMS & NCC

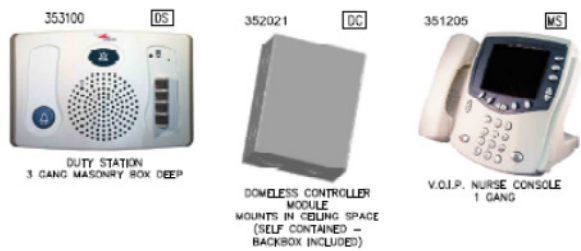

CABLE NUMBERS ARE THAT OF MOST FENH WIRE CORPORATION
(PLENUM GRADE CABLE)

CABLE LEGEND		
LETTER	CABLE DESCRIPTION	W.P. PLENUM #
E	2 CONDUCTOR, 14 AWG. CABLE	#25226
J	4 PAIR CAT 5E, UTP, 24 AWG.	GENERIC
N	4 CONDUCTOR, 22 AWG., STRANDED	#25241
O	1 CONDUCTOR, 14 AWG., GRN. THHN	GENERIC
D	3 PAIR ROUND, 24 AWG. (CAT3)	50980
Z	6 CONDUCTOR, 14 AWG CABLE	25246B

Fig 5. Common Rooms - Duty Stations

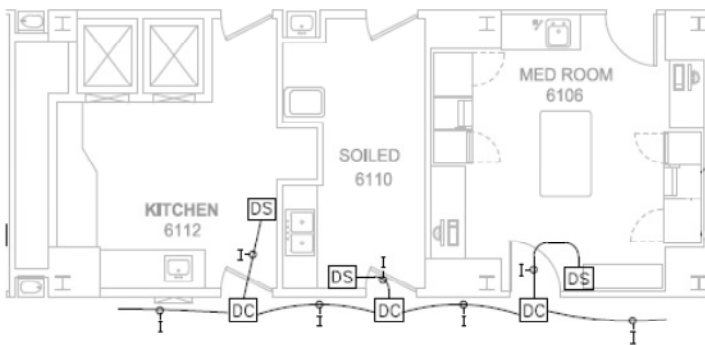
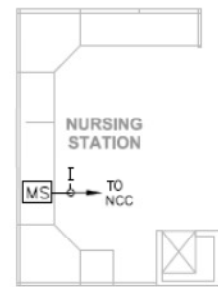
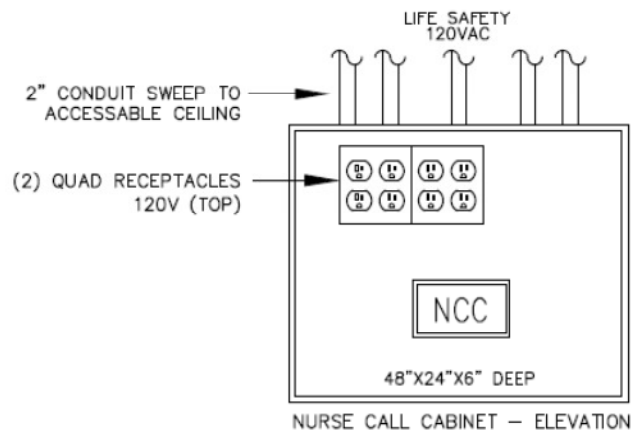

Fig 6. VoIP Console



Cable Run not to exceed 300'.

Fig 7. Nurse Call Cabinet (NCC)



TYPICAL RAULAND RESPONDER IV NURSE CALL LAYOUT - PATIENT ROOMS & COMMON ROOMS (i.e. Soiled/Clean Utility, Med Room)

NCPCS1 EP
Bath Pull Station (1 Gang)
3/4" conduit stub up

NCLD6 CL
LED Dome Light
4 - 11/16" J/B
w/1 Gang Ring

NCDUTY D
Duty Station
3G Masonry Box-Deep

NCBS1 P
Single Bed Station
3G Masonry Box-Deep

NCBSD2 P2
Dual Bed Station
3G Masonry Box-Deep

NCDPB2 CA
Code/Assist Station
1 Gang

NC2JACK M
2-Port Medical Alarm Jack Station
1 Gang

JB
4" Sq Junction box
w/cover above ceiling tile

LETTER	CABLE DESCRIPTION	W.P. PLENUM #
A	3 pair flat, 24 AWG cable	37125
B	4 pair flat, 24 AWG cable	37129
C	2 pair round, 24 AWG cable	55826
D	3 pair round, 24 AWG cable	54980
E	3 conductor, 14 AWG cable	25236B
P	1 cond, 18 AWG, Green, THHN	GENERIC
Z	4 conductor, 14 AWG cable	25246B

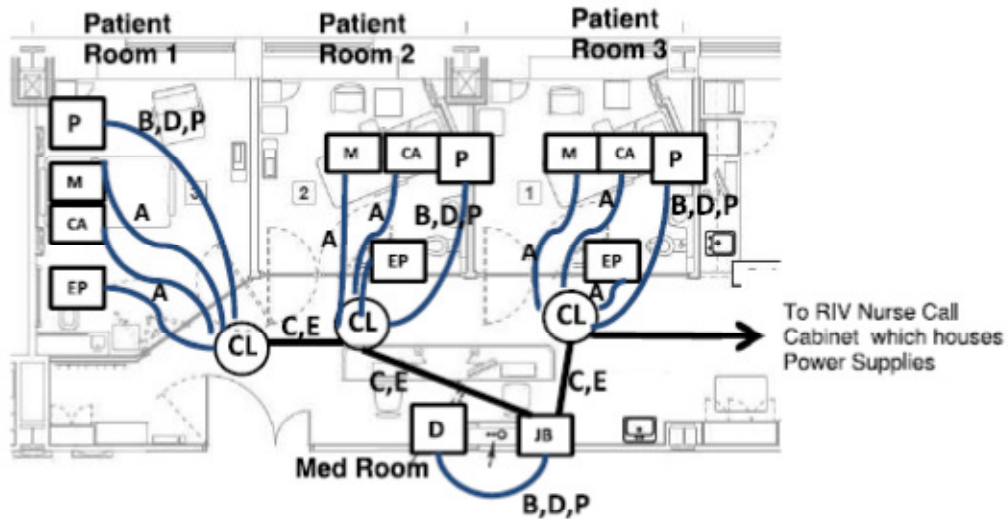

RAULAND RESPONDER IV NURSE CALL CONSOLE WIRING



**TYPICAL RAULAND RESPONDER 4000 NURSE CALL LAYOUT - TONE/VISUAL (NO VOICE)
EXAM ROOMS, BATHROOM & COMMON ROOMS (i.e. Soiled/Clean Utility, Med Room)**

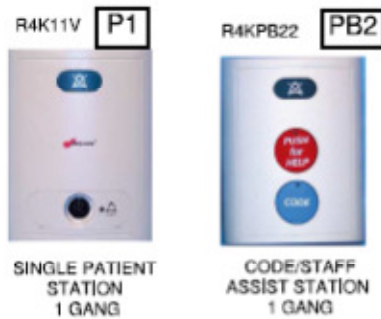
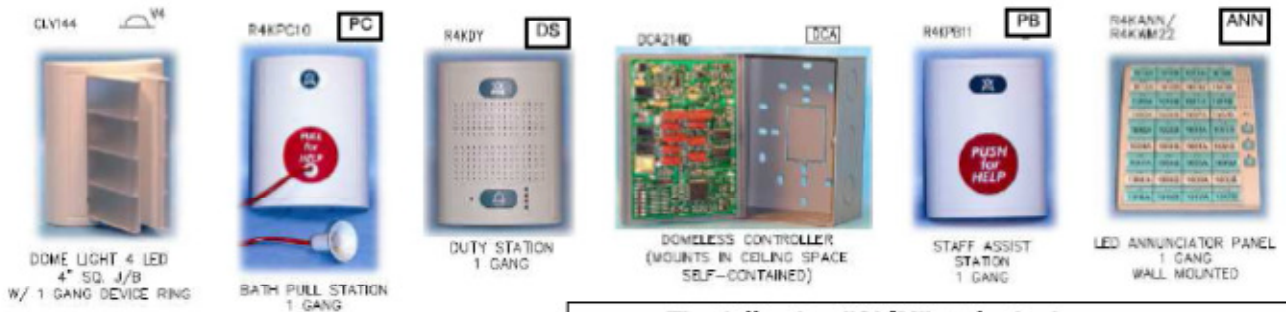

The following "SLIM" style devices may be used in lieu of the above style.

R4KPB23 **PB2**
CODE/STAFF
ASSIST STATION
1 GANG

R4KPC11 **PC**
BATH PULL
STATION
1 GANG

R4KDTY2 **DS**
DUTY STATION
1 GANG

R4KPB12 **PB**
STAFF ASSIST
STATION
1 GANG

RESPONDER 4000 NURSE CALL CABLE SCHEDULE

LETTER	CABLE DESCRIPTION	W.P. PLENUM #
I	4 Pair CAT5E, UTP, 24 AWG, Black	GENERIC

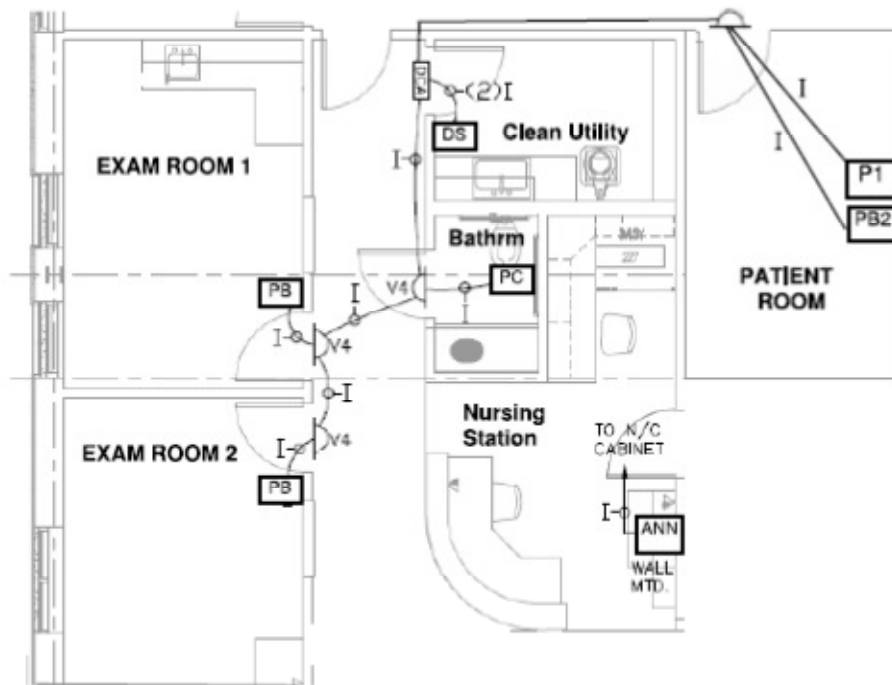

TYPICAL RAULAND RESPONDER 4000 NURSE CALL LAYOUT - VOICE/VISUAL PATIENT ROOMS

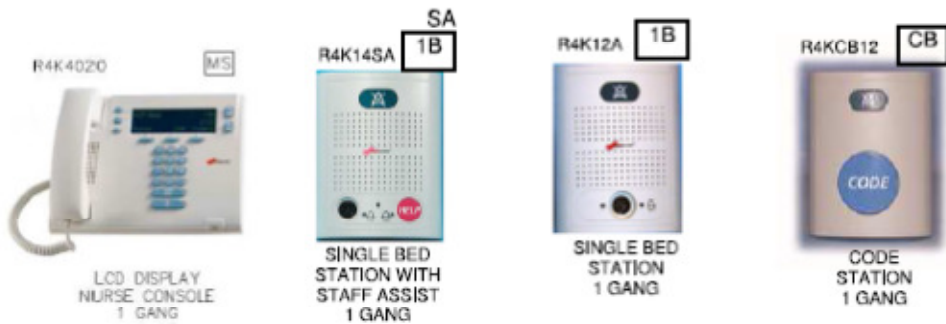

The following "SLIM" style devices may be used in lieu of the above style.



RESPONDER 4000 NURSE CALL CABLE SCHEDULE		
LETTER	CABLE DESCRIPTION	W.P. PLENUM #
I	4 pair CAT5E, UTP, 24 AWG cable, Black	GENERIC
N	4 conductor, 24 AWG, Stranded cable	25241

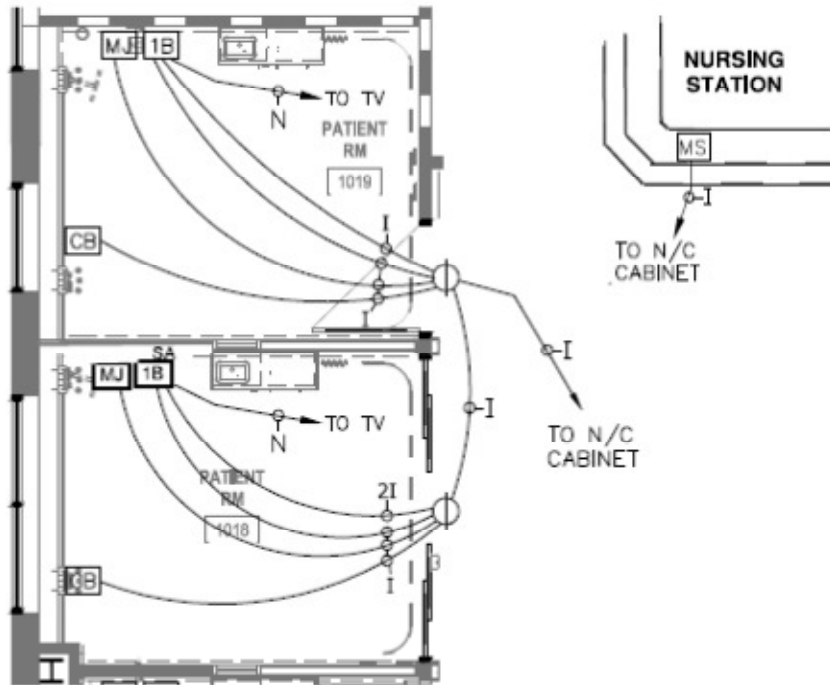

MMC Approved Products and Source List

All parts and descriptions for Rauland Nurse Call systems will be supplied by Signet Electronic Systems at the design phases of the project.

DRAFT

Appendix D

MaineHealth Approved Cabling Contractors

E.S. Boulos Co.

45 Bradley Drive
Westbrook, ME 04092
207-464-3706
207-464-1833 (Fax)
Contact: Dan Broy

Connectivity Point

P.O. Box 1268
Auburn, ME 04211-1268
207-782-0200
207-595-0058 (Cell)
207-753-0200 (Fax)
Contact: Tim Hooper

MTS Services

13 Delta Drive, Suite 7
Londonderry, NH 03053
603-845-1100
603-845-1119 (Fax)
Contact: Frank Cantwell

DRAFT

Appendix E

MaineHealth

Preferred Vendor List (Miscellaneous)

CCTV/ITV SYSTEMS

Howlands Associates
49 River Street
Plymouth, MA 02360
(508) 747-8332 (Office)
(800) 225-0256 PIN #147169 (Pager)
Contact: Ken Reardon

CATV/ITV SYSTEMS

Healthcare Television of New Eng., Inc.
26 Phillips Drive
Westford, MA 01886
(978) 692-7728 (Tech Support)
Contact: Jack Ryan
(413) 665-2844
Contact: Nancy Wilson (Sales)

NURSE-PATIENT CALL SYSTEMS (VISUAL or VOICE)

Signet Electronic Systems, Inc.
153 U.S. Route 1
Scarborough, ME 04074
781-871-5888 x2105
2-7-415-9797 (cell)
207-874-0600 (fax)

Appendix F

MH

Typical Telecommunications Room Design Plans

All Telecommunications Rooms (TRs) shall require at least one wall to be built-out with plywood material for use as a backboard in attaching systems enclosures such as nurse call, paging amplifiers, etc. Additional backboard walls may be requested as part of a project and detailed within the Scope of Work for the project. Backboard walls shall be 3/4" or 1" A/C grade Fire-retardant plywood. Plywood shall be painted with 2 coats of White Fire-retardant paint (including edges) leaving any UL listings un-painted. The backboard shall be mounted flush on the drywall or concrete wall. When applicable, all cabling shall be surface mounted on the backboard using 4" or 6" D-Rings for management.

Any power or voice/data outlets installed on this wall shall be at the 18" A.F.F. height. The racks shall be securely fastened to the floor at a distance of 36" from the wall when applicable. All layouts shall be approved before installation by MH Network Engineering.

Two Rack Example

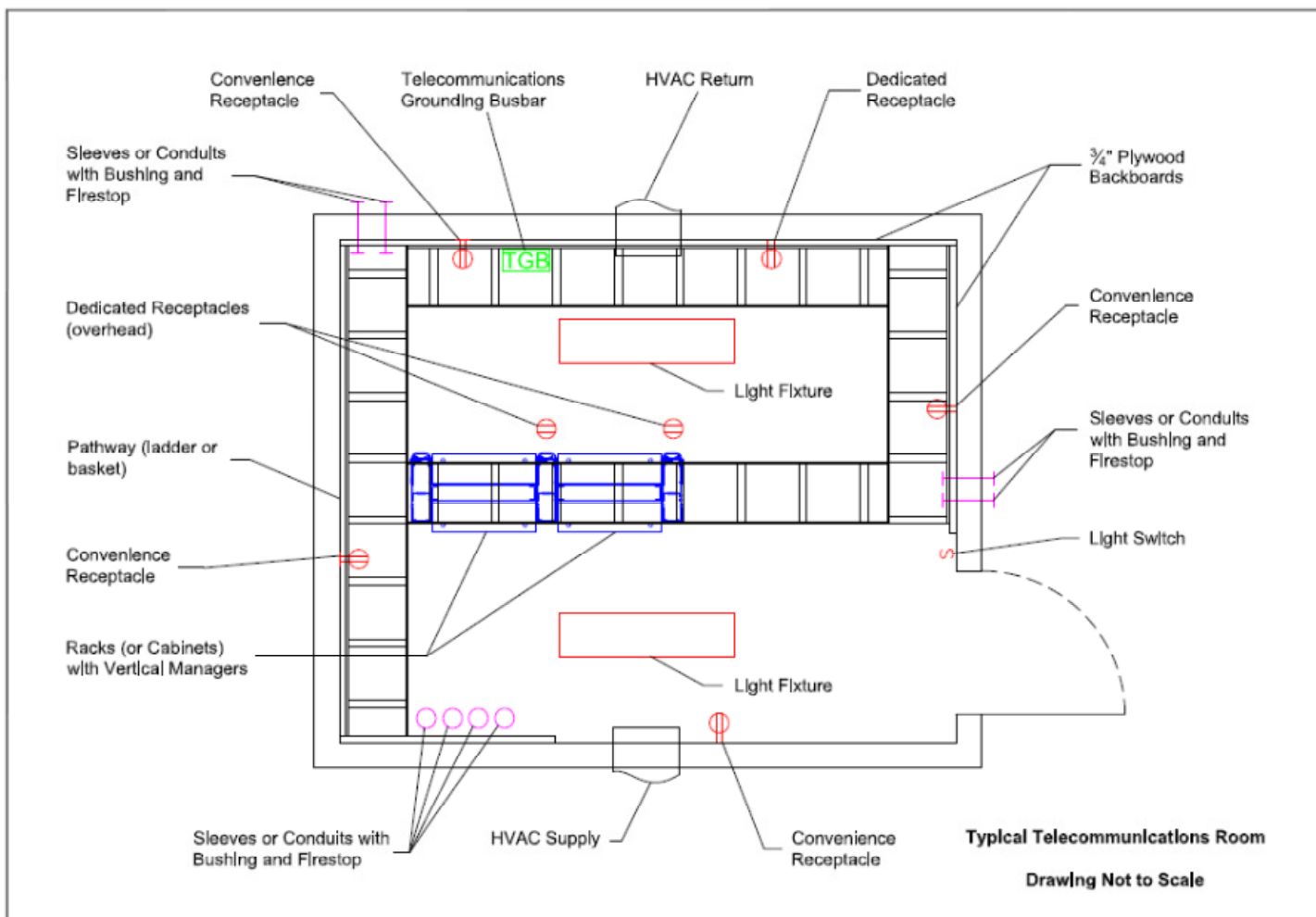

Appendix G (Continued)

MH

Standard Work Area Outlet Configurations

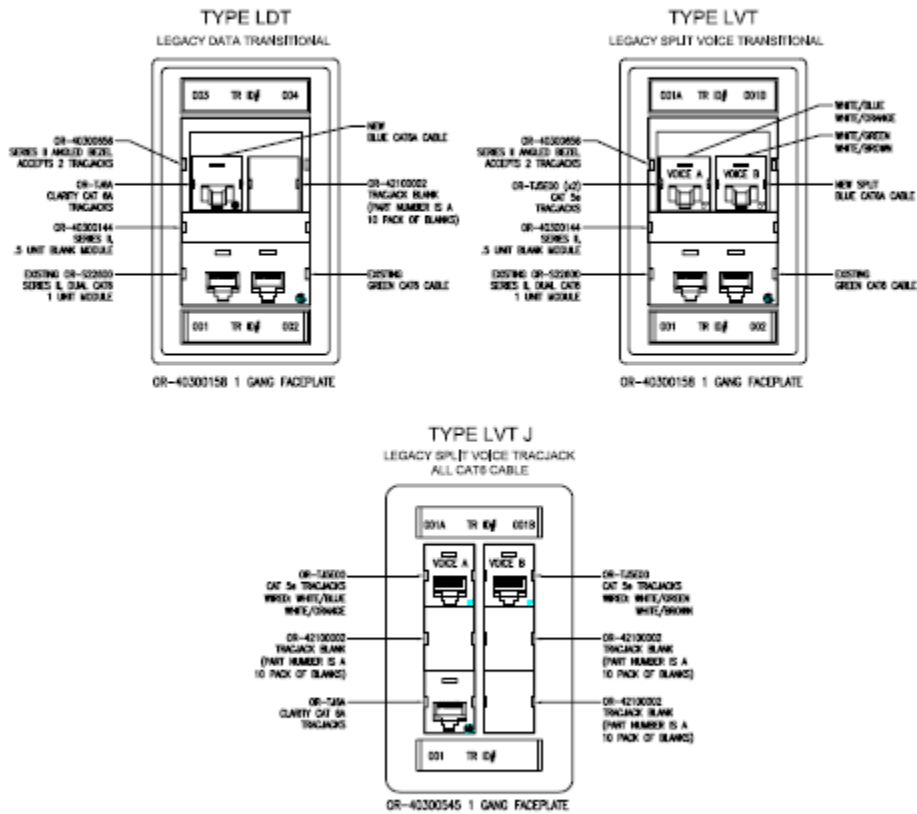

Appendix G (Continued)

MH Standard Work Area Outlet Configurations

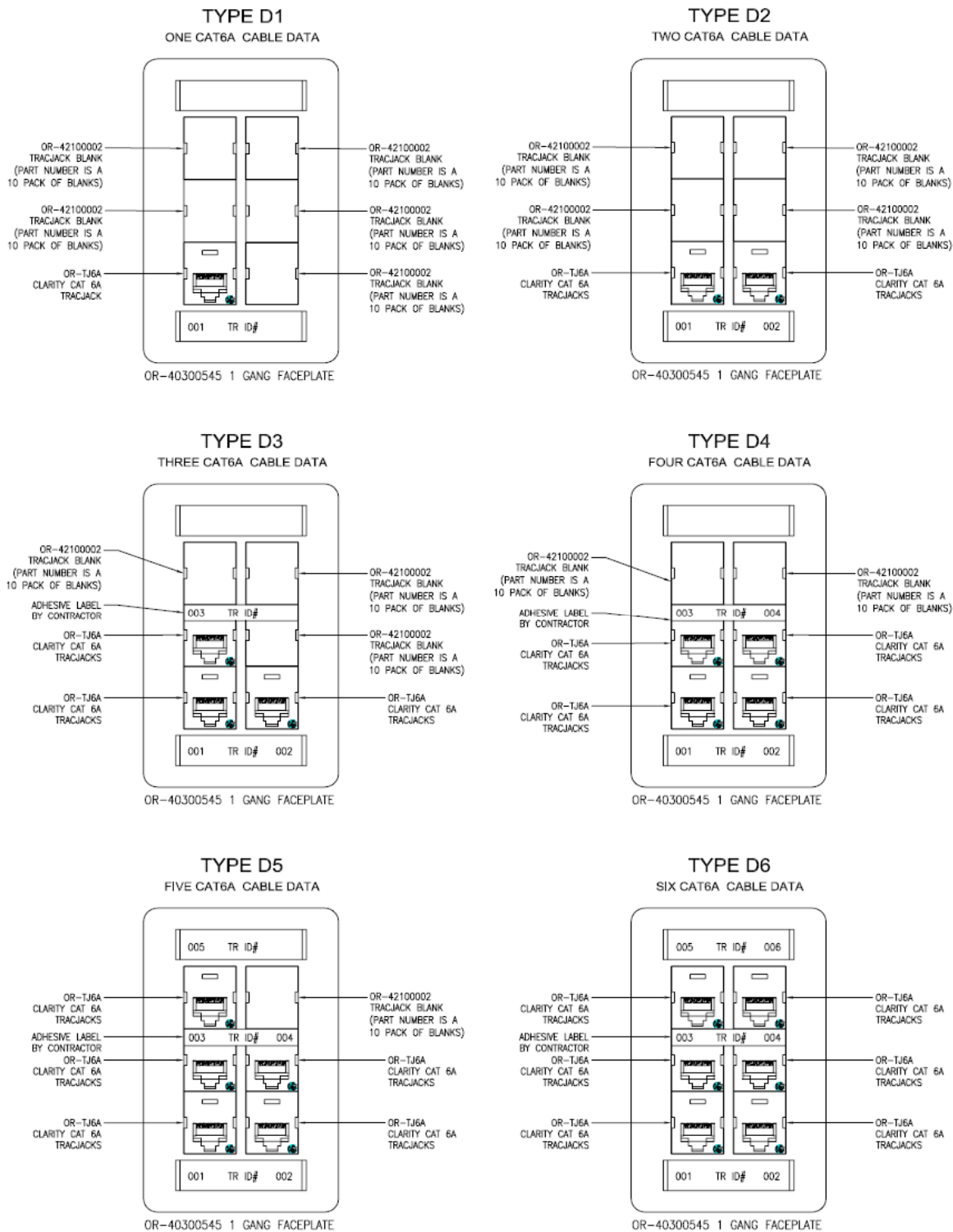











Appendix H











MH

Telecommunications Legend Standards (For use on Master Floor Plans)







Network Cabling Legend

-  CAT 6 dual drop, containing 1 voice and 1 data
-  Multi-cable location. X = # of cables to install
D_x, V_x
-  Single drop containing 1 data cable
-  X = # of CAT6 data cables to install
-  Single drop containing 1 CAT 6 voice cable
-  X = # of CAT6 voice cables to install
-  Data only for wireless access point
-  Wallphone CAT6 data cable
-  Wallphone CAT6 voice cable
-  Correct numbering for as-built
0123
-  COAX

Nurse Call Legend

-  Dual Bed Patient Station
-  Single Bed Patient Station
-  Emergency Station with Pull
-  Duty Station
-  Staff Station
-  Master Station
-  Corridor Lamp
-  Zone Lamp
-  Dual 1/4" FAM Device
-  Dual Push Button Station

Rough-In and Ceiling Legend

-  Horizontal Sleeve, diameter noted.
-  Vertical Sleeve, diameter and floor level penetration noted.
-  Cable Tray, size noted on SOW.
-  Grounding Bus Bar
-  19" rack with 6" cable management
-  Ceiling speaker, grid mounted
-  Wall mounted Volume Controller

Appendix I

Telecommunications Room Terminations - Data

All Category 6A terminations shall be installed in a uniform manner, which shall include a cable identification number on both ends of each cable.

Hook and Loop type fasteners shall be used for the finished install.

The Labeling for the Data Racks shall be as follows:

(On the Face of the Patch Panel) Starting from the top left and working to the top right and continuing in ascending numerical order from left to right through the remaining Patch Panels, the labeling shall be **001** through **999**.

This numbering sequence shall be adhered to throughout the MaineHealth campuses unless specifically noted in the Scope of Work for that project.

Example Rack

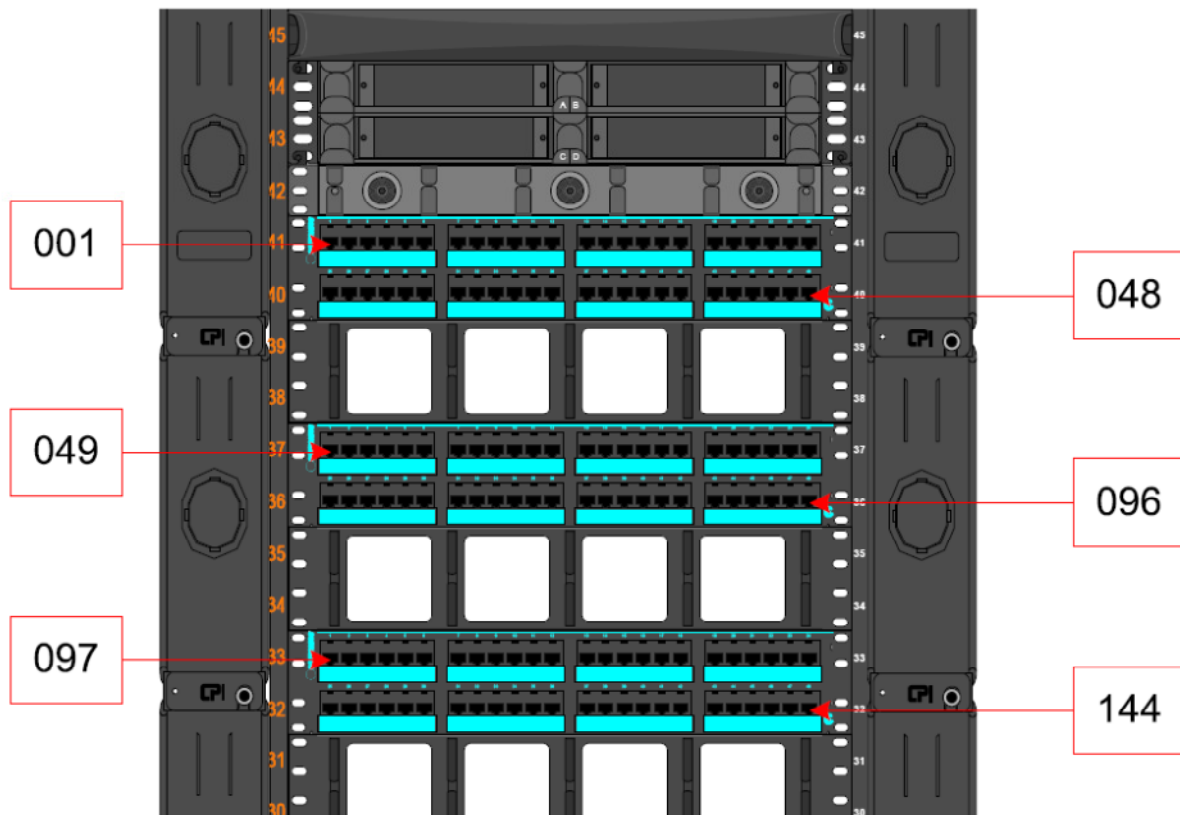

Appendix I (Continued)

Telecommunications Room Terminations – Voice

The Legacy Voice Frames in each TR (closet) shall be installed utilizing Belden (BIX) equipment. Typically, the Horizontal (Station) cables will be installed on the left side and labeled with Blue DESI labels. Typically, the Riser cables will be installed on the right side and labeled with White DESI labels. BIX management rings shall be installed for cross-wire installs from left to right. No BIX rings will be required on the extreme right side. **Voice Frame labeling shall be as follows:** Starting at the top left of the frame and working to the top right of the frame and continuing through to the end of the Station cable count the labeling shall be **001A** then two spaces and then **001B** in ascending numerical order to the end of the Station cables. The Riser cables shall be labeled with the next pair count from the Main Distribution Frame (MDF) and each 25 pair ID strip shall have the beginning and end pair labeled on the top and bottom of each ID strip until the complete cable has been identified. The Closet Identification number shall be included in the top and bottom center of each ID strip and shall include the cable origination point and the cable destination point and the pair count. An example of this is **0GPA3 to 0BPA1- 100pr**. This Frame Layout and numbering sequence shall be adhered to throughout the MH system unless specifically noted in the Scope Of Work for that project.

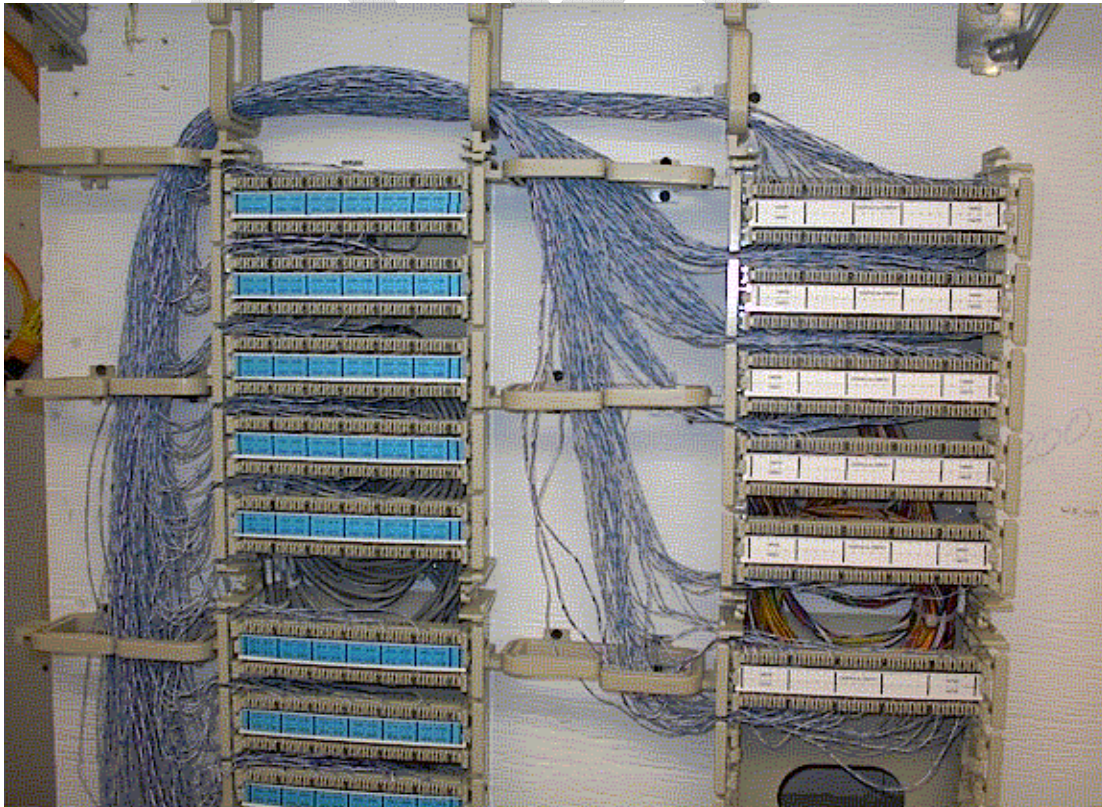

Appendix J

Grounding and Bonding for Communication Systems (Supplemental Specifications and Products)

PART 1: GENERAL

1.01 SCOPE OF WORK

- A.** Work covered by this Section shall consist of furnishing labor, equipment, supplies, materials, and testing unless otherwise specified, and in performing the following operations recognized as necessary for the installation, termination, and labeling of grounding and bonding infrastructure as described on the Drawings and/or required by these specifications.
- B.** Listed manufacturers and products are preferred. MH approved equal products are also acceptable with prior written approval.

PART 2: PRODUCTS

2.01 GROUNDING BUSBARS

A. Telecommunications Main Grounding Bus bar (TMGB)

- 1. Predrilled, copper, non-anodized. Chatsworth #40158-012 ground bus bar with Chatsworth #10622-000 bus bar insulators.

B. Telecommunications Grounding Bus bar (TGB)

- 1. Predrilled, copper, non-anodized. Chatsworth #40156-12 ground bus bar with Chatsworth #10622-000 bus bar insulators.

2.02 GROUNDING JOINTS AND SPLICES

- A.** Grounding conductor joints/splices shall be mechanical type, copper alloy, with a minimum of two bolts and a separate section for each conductor.
- B.** Grounding conductor terminations (lugs) shall be single barrel, mechanical screw type, and copper alloy with machined contact surfaces.

Appendix J (Continued)

2.03 BONDING CONDUCTORS

A. Cable Tray Bonding Conductor

1. Green #6 AWG insulated bonding jumper (12" max) with appropriate lugs or manufactured braided copper grounding jumper equal to B-Line #CAM-GJ, T&B #BD12, OZ/Gedney type "FB" or Mono-Systems.

B. Bonding Conductor (BC)

1. Green insulated copper bonding conductor, size as required by NEC. The BC shall be, as a minimum, the same size as the TBB.

C. Telecommunications Bonding Backbone (TBB)

1. Green insulated copper conductor, minimum size of No. 6 AWG. The TBB shall be sized at 2 kcmil per linear foot of conductor length up to a maximum size of 3/0 AWG. Insulation shall meet fire ratings of its pathway.

PART 3: EXECUTION

3.01 TELECOMMUNICATIONS INSTALLATION

A. Bonding and Grounding

1. Bond and ground all conduits, cable trays, racks and other infrastructure as per the NEC and TIA 607A to the main building ground.
2. Clean Surfaces. Nonconductive coatings (such as paint, lacquer, and enamel) on equipment to be grounded shall be removed from threads and other contact surfaces to ensure good electrical continuity or be connected by means of fittings designed so as to make such removal unnecessary.

B. Installation of the TMGB

1. Install the TMGB at the bottom of plywood backboard near the outside plant entrance conduits in the "BDF". TMGB shall be installed so that the BC for telecommunications is as short and straight as possible. Green insulated conductor shall be installed exposed. Connection at TMGB from main electrical service ground shall be thermo-weld type. Ground resistance shall not exceed 2 ohms, unless approved by UNM. Bus bar shall be predrilled for future connections. Provide label - "Do Not Disconnect" on connection to main electrical service ground.

Appendix J (Continued)

C. Installation of the TGB

1. Install the TGB at the bottom of plywood backboard near the copper riser terminations in each "IDF". TGB shall be installed so that the TBB for telecommunications is as short and straight as possible. Green insulated conductors shall be installed exposed. Bus bar shall be predrilled for future connections.

D. Installation of the TBB

1. Install Green insulated copper grounding conductor (refer to 2.03.D for conductor size) from the TMGB to each TGB.

E. Installation of Grounding Conductor Joints/Splices

1. Install mechanical type, copper alloy, with a minimum of two bolts and a separate section for each conductor or copper compression type with two (2) indents. Install manufactured insulating cover or heavy tape insulation over joints/splices.

F. Grounding of Cable Tray

1. Install Green #6 AWG bonding jumper (12" max) with appropriate lugs at each cable tray joint or install manufactured braided copper grounding jumper. In lieu of bonding jumpers, approved grounding type connectors to connect sections of cable tray will be permitted. Install Green #6 AWG grounding conductor with appropriate lugs from side of cable tray down to TMGB or TGB. Drill and tap side of cable tray (for appropriate size bolt, 1/4" x 20 min.), making sure that bolt does not extend into wire management part of tray.

G. Grounding of Telecommunications Duct bank

1. Provide a continuous #4/0 bare stranded drawn copper conductor within the concrete at the bottom of all duct banks. Terminate to bonding ribbon in telecommunications manholes.

Appendix J (Continued)

H. Grounding of Telecommunications Maintenance Holes and Hand holes

1. Provide bonding jumper to reinforcing steel in each section. Install a bonding ribbon horizontally around the top of each manhole and attach to all cable racks and metallic hardware within the manhole. Continue installation vertically between bonding clamps so both top and bottom halves are bonded together on each side. (The bonding ribbon will be used to bond and ground all future splice cases and hardware placed within the manhole.) Provide a ground rod near the center of each manhole and hand hole. Bond to the bonding ribbon in manholes.

Note: Pre-cast maintenance holes (manholes) having reinforcing steel bonded together do not require an additional ground rod.

Appendix K

Primary Protection for Communication Systems

1. Contractors shall furnish the appropriate model, size and type of UL Listed primary (lightning) protection equipment to provide maximum protection of electronic equipment that is connected to any outside plant cabling.
2. 5-Pin Solid State modules with a voltage rating appropriate to the application shall be utilized for all protection units.
3. MaineHealth prefers to use primary (lightning) protection products from Circa. Other manufacturers such as Porta Systems are also acceptable subject to MH Network Engineering review and require written approval.
4. All Primary (lightning) protection shall be installed to manufacturer's specifications and in adherence to all UL, NEC, State and Local code requirements for primary protection units.
5. Grounding of Primary Protection units must adhere to the requirements in Appendix J of this document in addition to the manufacturer specific installation requirements.

Appendix L

Fire Stopping

PART 1 GENERAL

1.01 DEFINITION

- A.** Fire Stopping: Material or combination of materials to retain the integrity of fire rated construction by maintaining an effective barrier against the spread of flame, smoke, and gases.
- B.** Through-Penetration Firestop Systems: Material or combination of materials which are field-constructed of fill, void, or cavity materials and forming materials, designed to resist fire spread when installed as a complete Firestop system.
- C.** Through-Penetration Firestop Devices: Factory built products designed to resist fire spread. Complete when delivered to site; ready for installation.

1.03 SUMMARY

- A.** Provide labor, materials, services, coordination, and equipment necessary for complete installation of Firestopping materials.
 - 1.** Provide through-penetration Firestop systems and through-penetration Firestop devices, sealants, and related products for floor and wall penetrations (and sealing top of rated walls to deck when required by code officials). Work includes, but is not limited to conduits and low voltage cables.

1.04 SUBMITTALS

- A.** Product Data: Manufacturer's data indicating product characteristics, performance, and limiting criteria.
- B.** Proposed Installation Drawings: Show typical installation details for methods of installation.
- C.** Documentation of qualifications as Firestopping installer is required.
- D.** MSDS sheets, for each product to be used, shall be provided to the individual responsible for site coordination of MSDS information.
- E.** Certification is required from manufacturer that Installer has been trained in the handling and installation of their products.

Appendix L (Continued)

Firestopping

1.05 QUALITY ASSURANCE

A. Conform to applicable governing codes:

1. Maine State Building Code

B. Meet requirements of ASTM E814 Through Penetration Fire Test by a nationally recognized testing agency and other ASTM Standards as applicable for the installation.

1. ASTM E84 "Test Method for Surface Burning Characteristics of Building Materials."
2. ASTM E119 "Test Methods for Fire Tests of Building Construction and Materials."
3. ASTM E136 "Test Method for Behavior of Materials in a Vertical Tube Furnace at 750 degrees C."
4. ASTM E162 "Standard Method for Surface Flammability of Materials Using a Radiant Heat Energy Source."
5. ASTM E662 "Test Method for Specific Optical Density of Smoke Generated by Solid Materials."
6. ASTM E814 "Test Method for Fire Tests of Through-Penetration Firestops."

C. Installer shall have successfully completed within the last 3 years at least 2 Firestop projects similar in type and size to that of this Project. The installers are required to have been trained by each manufacturer of products they are installing and in the proper handling and installation of that product. Additionally, all contractors must complete MH's Contractor Orientation process prior to performing any Firestopping tasks in MH facilities.

D. Obtain Firestop materials from a single manufacturer for each different application (UL Listed Solution) using only the products listed for that solution.

E. Application Certification: Upon completion of the Work, the Contractor shall furnish to the Architect certification that materials have been installed in accordance with manufacturer's installation requirements. The installer shall sign certification.

F. Contact the manufacturers of each product intended for use for a list of qualified Firestop Specialty Installers.

Appendix L (Continued)

Firestopping

1.06 PRODUCT DELIVERY AND STORAGE

A. Deliver materials to project site in manufacturer's original unopened containers with labels indicating brand names. Store and protect accepted materials in accordance with manufacturer's directions and recommendations.

1.07 SEQUENCING

A. Coordinate this Work as required with work of other trades. Coordinate with other Contractors to make or keep penetration areas accessible to Firestopping installer.

PART 2 PRODUCTS

2.01 ACCEPTABLE MANUFACTURER'S PRODUCTS

A. Penetration Sealants

(Note: These products only apply to MMC and MMP. Consult local Engineering staff for product types at other MH Member sites. All products must be approved by MH Network Engineering)

1. 3M Brand "Fire Barrier" Caulk.
2. 3M Brand Moldable Putty "Pads" and Moldable Putty "Stix".

C. Intumescent sealants and Firestopping bags for use in openings and sleeves involving plastic pipe, insulated pipe, or flexible cable:

D. 3M Brand "Fire Barrier" Caulk, with FS-195 Wrap Strip and CS-195 Composite Sheet.

E. Specified Technologies (STI) EZ-Path Series and Ready Firestop Grommets (With MH Network Engineering approval only)

C. Penetration Systems

1. 3M Quick Path/Easy Path Fire Stopping systems.
2. Specified Technologies EZ-Path Series and Ready Firestop Grommets (With MH Network Engineering approval only)

2.02 MATERIALS - GENERAL

A. Provide flame (F) rating minimum one hour, but not less than fire resistance rating of the assembly in which installed, per ASTM E814.

B. Maintain effective barrier against flame, smoke, and hot gasses per ASTM E814 and UL 1479.

C. Suitable for Firestopping of penetrations by steel, glass, plastic, and insulated pipe. Also Flexible cable, bus duct, and cable tray.

PART 3 EXECUTION

3.01 EXAMINATION

A. Examine surfaces to receive penetration sealant or foam and report unacceptable conditions to the MH Network Engineering project resource before starting Firestopping work. Start of work indicates Firestopping installer's acceptance of sizing of holes and application conditions.

B. Each trade must control sizing of their penetration holes made to accommodate their penetrating items.

3.02 PREPARATION

A. Clean penetration holes of dirt, loose materials, and foreign matter, which may affect bond or installation.

B. Remove coatings such as paint, curing compounds, water repellent, and sealers as required.

3.03 APPLICATION

A. Installation of Firestopping Materials: Install Firestopping materials, including forming, packing, and other accessory materials to fill openings around mechanical and electrical services, penetrating floors and walls to provide firestops with fire resistance ratings indicated for floor or wall assembly in which penetration occurs. Comply with installation requirements established by testing and inspecting agency.

B. Install Firestopping materials systems in strict accordance with manufacturer's installation instructions and code requirements.

C. Employ installation techniques that will ensure that Firestopping is deposited to fill and seal holes and openings.

- 1.** Provide flame (F) rating minimum one hour, but not less than fire resistance rating of the assembly in which installed, per ASTM E814. Ensure effective smoke seal. Tool exposed surfaces of applied sealant smooth.

3.04 CLEAN-UP

Appendix L (Continued) Fire Stopping

A. Clean surfaces adjacent to sealed joints free of excess sealant and soiling from this Work as work progresses, using solvent or cleaning agent recommended in writing by the sealant manufacturer.

B. Leave finished Work in neat, clean condition; remove excess debris and materials.

DRAFT

Appendix M

General Contractor Assumptions

General assumptions list for detailing IS/IT/AV/Telecom related items

- 1) The General Contractor (GC) will provide all cable tray, backboxes, pull strings, conduit, J hooks, and Firestopping (approved MH/MMC systems) for all IS/AV/Telecom pathways and low voltage cabling. All device locations to be shown on the electrical construction document CAD prints. That includes cable tray size and pathways.
- 2) All IS/IT/Telecom cabling to be provided by MH/MMC. The MH/MMC Project Management Office (PMO) in conjunction with Network Engineering will bid out this work to our approved vendors.
- 3) All ceiling and wall mounted power for AV equipment (cameras, plasmas, etc....) will be provided by the GC. The Architects/Engineers will mark-up the locations on the Construction Documents (CD) per MMC IS/IT/Telecom.
- 4) OSP conduits will be provided by the GC to the nearest, or most accessible, Maintenance Hole (MH) to support the installation of MH/MMC dark/private fiber. OSP Conduit counts will be determined by the MH/MMC project team.
- 5) All new OSP conduits should have continuous interduct and pull strings in them. The MH/MMC standard for interduct is MaxCell. Any deviation from this standard will need to be approved by MH Network Engineering.
- 6) All nurse call end user device selection and locations to be provided by MH/MMC Telecom. All system design (loads, power calculations, core equipment requirements, cabling specifications and as-builts) and equipment (hardware and software) to be provided and installed by a MH/MMC approved vendor. Nurse call cabling to be provided and installed by a MH/MMC approved contractor (see spec list).
- 7) All security, alarming, fire system, white noise, and other BES/BAS cabling done by others and shall not be placed in the IS network rooms (except security). All systems not listed here will need to be approved by the Manager of MH Network Engineering.

Appendix M (Continued)

General Contractor Assumptions

- 8) All network rooms and equipment rooms will comply with BICSI standards. Layouts (rack locations, power, ladder tray, etc...) to be provided by the MH/MMC PMO with the support of MH Network Engineering.
- 9) Any radio or paging augmentations needed in the new building will be provided by the General Contractor. A survey of the design (pre-construction) and space should be conducted by RCM. That design should be signed off by MH IS/IT, Security and Engineering.
- 10) All new network and equipment rooms will have MH/MMC card access for security and auditing as well as the appropriate cooling (HVAC) by the GC.
- 11) All power required for network, nurse call, paging and any other IS item will be provided by the GC. MH/MMC IS will provide a print detailing each location and the power type (NEMA numbers if known).
- 12) Any payphone locations will be planned in advance and approved by MH/MMC IS. The GC will have ownership of all blocking and power needed to support these devices.
- 13) MH/MMC IS will work with the design team on all ceiling mounted items (WAPs, speakers, nurse call) and mark up a reflective ceiling print showing preferred locations for each item. GC will provide tile and grid specifications to allow for procurement of appropriate mounting solutions.
- 14) All TV and AV blocking and power to be provided by the GC. MH/MMC IS will show locations of each item.
- 15) Clinical Engineering and Security items are outside the scope of MH/MMC IS. Please contact the leads from those departments for any CE or Security questions related to this project.
- 16) Any hardware (surge protectors, PC brackets, phone chargers, etc....) that needs to be installed on walls will be completed by the GC.

Appendix M (Continued)

General Contractor Assumptions

- 17) Wireless access points, cable pathway, and rough-in for the elevators and stairwells will be installed by the GC. MH/MMC to provide WAPs and cable. GC to get permit and install as specified by MH/MMC.
- 18) All mill work grommets to be provided by the GC. Default placement to be over all under-the-counter data locations and power outlets.
- 19) All back boxes noted for IS/IT use shall be painted or have colored bushings on them using the following color scheme. Clinical Engineering = Orange, Security = Pink, MH/MMC IT = Blue, MH/MMC IT wall phones = Green, Cable TV = Yellow, Nurse Call = Black, Non-Integrated Pillow Speakers = Purple. Any other systems/colors will need to be approved by the MH project team.
- 20) All common areas (waiting rooms, nurse stations, charting spaces, etc.....) will have power outlets with built in USB connections for charging of portable devices.

Note: If no GC, then the building owner will provide items noted above. The IS/IT budget does not cover GC or building owner items noted on this document.

Appendix N

OverHead Paging Systems and Specifications

(Systems Vary at MH Sites)

MMC Systems

Special Work Results – Overhead Paging 1 (Bogen) – 27 15 00.46

- B. Bogen 100 Watt Paging Amplifiers are used at MMC. Volume control attenuators (as indicated on project prints) and speakers shall be arranged in a daisy-chain fashion. Amplifiers shall have no more than 45 speakers attached. Installations with more than 1 paging amplifier will utilize an audio distribution amplifier to control impedance and stabilize output levels.
- C. Individual paging speakers are set at 2.0 Watts
- D. The contractor shall perform all terminations at the speaker end using cable and UL Listed termination equipment and enclosures supplied by the contractor. All speakers will be secured independently using jack chain or approved equivalent.
- E. The MH Telecommunications Dept. will perform the final connections to the paging network.
- F. Cabling for Bogen overhead paging applications is Plenum rated 16 gauge, single twisted pair, double jacketed cable (West Penn catalog # 25294B or=)
- G. Each speaker shall have it's transformer set for 25 or 70 volts to match the paging amplifier and will be set for 2.0 Watts output with the volume control at 50%. MH Telecommunications will provide the correct voltage setting and MH Network Engineering will include it within the SOW document.
- H. Speakers locations will be specified by the system owner.
- I. Each speaker run will be tested to determine the load on the system using an impedance meter and this information shall be noted on the as-built documentation for the project.

Special Work Results – Overhead Paging 2 (Valcom) – 27 15 00.46

- A. An alternate paging system is in use in some MMC facilities that utilizes products manufactured by Valcom. The Valcom system uses standard [4-Pair Blue Category 6A UTP cable](#) for speakers and is a 25 Volt System. Each Speaker cable is a home run from the speaker back to the originating TR where the cables are terminated on the backboard using BIX type connecting blocks and labeled "Overhead Paging"

END OF DOCUMENT

DRAFT

SECTION 27 05 00

COMMON WORK RESULTS FOR COMMUNICATIONS

PART 1 - GENERAL

1.1 RELATED DOCUMENTS

- A. Drawings and general provisions of the Contract, including General and Supplementary Conditions and Division 1 Specification Sections, apply to this Section.
- B. 232123Section 01 81 13 "Sustainable Design Requirements – LEED v4 for Building Design & Construction – New Construction" for sustainable design requirements and detailed sustainable design submittal requirements.
- C. Section 01 74 19 "Construction and Demolition Waste Management and Disposal" for disposal of construction, demolition and packaging waste disposal requirements.

1.2 SUMMARY

- A. This Section includes the premise telecommunications cabling system.
- B. As a condition of Contractor's use of these specifications, Contractor agrees (i) to name AKF as additional insured on Contractor's insurance policies wherever permitted, (ii) to provide AKF, upon request, with a certificate of insurance and copies of specific endorsements to Contractor's insurance policies evidencing said additional insured status, and (iii) to waive all rights of recovery against AKF by way of subrogation, assignment, or otherwise with regard to insured claims.
- C. Related Sections include the following:
 - 1. Division 26 Electrical Sections
 - 2. Division 1 Sections
- D. The work covered by this specification includes the construction described, including all labor necessary to perform and complete such construction; all materials and equipment incorporated or to be incorporated in such construction; and all services, facilities, tools and equipment necessary or used to perform and complete such construction.
 - 1. F&I all workstation jacks, connectors, terminating devices, faceplates, and similar components required for a complete installation.
 - 2. F&I all cable supports (J-hooks), including mounting and installation hardware required for a complete installation.
 - 3. F&I all labeling and documentation of all cables, racks, outlets and hardware installed under this contract. The Contractor shall ensure that all labeling and numbering is in accordance with the Owner's in-house standards.
 - 4. Provide all testing and test documentation as described in the testing section.
 - 5. Label and document all new and existing-to-remain cables.
 - 6. Provide all connections to the telecommunications grounding system.

7. Provide all fire-stopping of all rated wall and floor penetrations and openings through rated walls and floors after installation of telecommunications cabling.
8. F&I all non-specified miscellaneous hardware, including, but not limited to nuts, bolts, re-enterable cable ties, spiral wrap, wire rings, supporting hardware and similar components required for a complete cabling system installation.
9. Certain terms such as "shall, provide, install, complete, etc." are not used in some parts of these Specifications. This does not indicate that the items shall be less than completely installed or that systems shall be less than complete.

E. Sustainable Building Requirements:

1. The Owner requires the Contractor to implement practices and procedures to meet the project's environmental performance goals, which include achieving LEED version 4 **Certified** level Certification. Specific project goals that may impact this area of work include: use of recycled-content materials; use of locally-manufactured materials; use of low-emitting materials; construction waste recycling; and the implementation of a construction indoor air quality management plan. The Contractor shall ensure that the requirements related to these goals, as defined in the Articles below, are implemented to the fullest extent. Substitutions, or other changes to the work proposed by the Contractor or their Subcontractors, shall not be allowed if such changes compromise the aforementioned environmental goals and LEED certification.

1.3 SUBMITTALS

- A. Product Data: For each product indicated.
- B. Field Test Reports

1.4 QUALITY ASSURANCE

- A. Furnish all materials in new and unused condition, free from defects, damage or corrosion. All materials shall meet all applicable codes provided a standard has been established for the material in question.
- B. Comply with all applicable governmental regulations and with all Federal, State, County, City, and other applicable codes, ordinances, and regulations and the most recent edition of the following technical standards and design guidelines:
 1. ANSI/TIA/EIA-568 Standard for Installing Commercial Building Telecommunications Cabling (latest edition).
 2. ANSI/TAI/EIA-569 Standard for Installing Commercial building Telecommunications Pathways & Spaces, (latest edition).
 3. ANSI/TIA/EIA-606 Administration Standard for Commercial Telecommunications Infrastructure (latest edition).
 4. ANSI/TIA/EIA-607 Commercial Building Grounding (Earthing) and Bonding Requirements for Telecommunications (latest edition).
 5. BICSI, Telecommunications Distribution Methods Manual (latest edition).
- C. It is the intent of these Specifications to provide a complete workable telecommunications cabling system including optical fiber, coaxial and unshielded twisted pair cable, and ready for the Owner's use.

1.5 DELIVERY, STORAGE AND HANDLING

- A. Deliver materials (except bulk materials) in manufacturer's unopened container, fully identified with manufacturer's name, trade name, type, grade, size and color.
- B. Store materials suitably sheltered from the elements, but readily accessible for inspection until installed. Store all items subject to moisture damage in dry, climate controlled spaces.
- C. Store all materials in a secure manner to prevent loss. Contractor shall be responsible for any loss or damage of materials prior to Owner's acceptance thereof.

1.6 COORDINATION

- A. Carefully check space requirements and the physical confines of the area of work to insure that all material can be installed in the spaces allotted thereto.
- B. Transmit to other trades in a timely manner all information required for work to be provided under their respective Sections in ample time for installation.
- C. Wherever work interconnects with or contacts the work of other trades, coordinate with other trades to insure that all trades have the information necessary so that they may properly install all the necessary connections and equipment. Identify all items of work that require access so that the floor tile trade will know where to install tile cutouts.
- D. When directed by the Owner, the Contractor shall, without extra charge, make reasonable modifications in the layout as needed to prevent conflict with work of other trades or for proper compliance with the design intent.

1.7 WARRANTY

- A. Provide a Warranty in accordance with the Contract Documents.
- B. All work and all items of equipment and materials shall be warranted for a minimum period of one year from the date of acceptance of the work. Where manufacturer's warranty is longer than one year, the Contractor shall offer the extended warranty.
- C. Provide Maine Medical Center with both Ortronics (Legrand) and Corning Cabling Systems extended product and applications assurance warranties.

PART 2 - PRODUCTS

2.1 GENERAL

- A. Any given item of equipment or material shall be the product of one manufacturer unless otherwise noted or approved.
- B. Substitutions or alternates for the manufacturers listed will not be permitted without the written consent of the Consultant.

PART 3 - EXECUTION

3.1 GENERAL

- A. Follow manufacturers' instructions for installing all telecommunications cabling. Where instructions are unavailable, follow approved industry practice.
- B. Compare communications drawings and specifications with the drawings and specifications of other trades, report any discrepancies to the Consultant; and obtain written instructions for changes necessary in the work. Include most stringent requirements in bid.
- C. Repairs or changes caused by contractor's neglect shall be made at contractor's expense. Protect finished work of other trades from damage or defacement and remedy any damages as required.
- D. Clean up all debris generated by installation activities on a daily basis and discard as directed by the Construction Manager.
- E. Maintain a current copy of this Specification and related Drawings at the job site at all times.

3.2 CABLE DISTRIBUTION

- A. Follow room boundaries when pulling cables through ceilings for distribution into walls, conduits, wiring channels, outlets, etc.
- B. All cable distribution from the communications closets to all work locations (except as noted) shall be run in the voids above ceilings as shown on drawings. Ceiling support grids and service hangers shall not be used to support cabling.
- C. Cable shall be loose bundled into cable supports. Use only approved re-enterable cable ties to secure cables in overhead distribution.

3.3 EMI/RFI AVOIDANCE

- A. To avoid electromagnetic interference (EMI) route cables to maintain the following minimum distances:
 - B. Twelve inches from high voltage lighting.
 - C. Thirty-six inches from power lines of 5 KVA or greater.
 - D. Forty inches from transformers or motors.
- E. Maintain minimum twelve-inch separation between telecommunication cables running exposed in ceiling or floor voids and parallel electrical cables/conduits.
- F. Telecommunication cables shall cross electrical cables/conduits only at 90 degree angles.

3.4 STAFFING

- A. Designate a qualified foreman. The foreman shall be present in the field at all times during the performance of the work.
- B. Provide a supervisory work force sufficient to maintain efficient performance of the contractor's responsibilities.

- C. Use only skilled and reliable work force and discontinue the services of anyone employed on this project upon written request by the Owner, Architect, Construction Manager or Consultant.
- D. Use personnel who are qualified (at minimum) to perform all of the installation and testing work activities required under the contract.
- E. Provide and use the proper tools in good working order for the performance of the work. The consultant reserves the right to review the tools and tool maintenance procedures of the contractor and require replacements to be obtained.
- F. Telephone and data industry cable installation standards, TIA/EIA and BICSI standards, and manufacturers' instructions shall be used for in-process quality control and final acceptance of the work.

3.5 CABLE SLACK

- A. Provide a minimum of 12-inches of slack at each terminal box or behind each faceplate after jack installation is completed to allow for easy dismounting and extension of outlet covers and wire terminations.
- B. Provide a minimum of 5-foot slack in a loop in UTP at the head of each stub-up or distribution conduit.
- C. Provide a minimum of 8-foot slack in a loop in optical fiber cable at its point of entry to an equipment room.
- D. Provide a minimum of 20-foot slack for overhead mounted Wireless Access Point outlets.

3.6 FIRE STOPPING

- A. Seal all penetrations through fire rated walls, floors and walls created by or made on the behalf of the contractor so that the original fire rating of the floor or wall is maintained as required by Article 300-21 of the National Electric Code.
- B. Use sealant material that has passed fire exposure testing in accordance with standard time-temperature curve in the standard, UL, ASTM E 119, and NFPA 251 and the hose stream test in accordance with UL 10B.
- C. Provide removable fire-stopping pillows (IPC flame safe seal bags or approved equivalent) in an approved fashion in openings greater than 4" diameter, or 4" x 4" square cross section. Provide wire mesh grate over bags as recommended by manufacturer subsequent to installation.

END OF SECTION

This page is intentionally left blank.

SECTION 27 05 26

GROUNDING AND BONDING FOR COMMUNICATIONS SYSTEMS

PART 1 - GENERAL

1.1 RELATED DOCUMENTS

- A. Provide all labor, materials, and equipment for the complete installation of work called for in the Contract Documents.
- B. 232123Section 01 81 13 "Sustainable Design Requirements – LEED v4 for Building Design & Construction – New Construction" for sustainable design requirements and detailed sustainable design submittal requirements.
- C. Section 01 74 19 "Construction and Demolition Waste Management and Disposal" for disposal of construction, demolition and packaging waste disposal requirements.

1.2 SCOPE OF WORK

- A. This section includes the minimum requirements for the equipment and cable installations in communications equipment rooms (Telecommunications Closets).
- B. B. Included in this section are the minimum composition requirements and installation methods for the following:
 - 1. Busbars
 - 2. Bonding accessories
- C. Sustainable Building Requirements:
 - 1. The Owner requires the Contractor to implement practices and procedures to meet the project's environmental performance goals, which include achieving LEED version 4 **Certified** level Certification. Specific project goals that may impact this area of work include: use of recycled-content materials; use of locally-manufactured materials; use of low-emitting materials; construction waste recycling; and the implementation of a construction indoor air quality management plan. The Contractor shall ensure that the requirements related to these goals, as defined in the Articles below, are implemented to the fullest extent. Substitutions, or other changes to the work proposed by the Contractor or their Subcontractors, shall not be allowed if such changes compromise the aforementioned environmental goals and LEED certification.

1.3 QUALITY ASSURANCE

- A. All cable and equipment shall be installed in a neat and workmanlike manner. All methods of construction that are not specifically described or indicated in the contract documents shall be subject to the control and approval of the Owner or Owner Representative. Equipment and materials shall be of the quality and manufacture indicated. The equipment specified is based upon the acceptable manufactures listed. Where "approved equal" is stated, equipment shall be equivalent in every way to that of the equipment specified and subject to approval.

- B. Strictly adhere to all Building Industry Consulting Service International (BICSI), Electronic Industries Alliance (EIA) and Telecommunications Industry Association (TIA) recommended installation practices when installing communications/data cabling.
- C. Material and work specified herein shall comply with the applicable requirements of:
 - 1. ANSI/TIA/EIA - 568-B Commercial Building Telecommunications Cabling Standard, latest edition.
 - 2. ANSI/TIA/EIA - 569 Commercial Building Standard for Telecommunications Pathways and Spaces, latest edition.
 - 3. ANSI/TIA/EIA - 606-A Administration Standard for the Telecommunications Infrastructure of Commercial Buildings, latest edition.
 - 4. ANSI-J-STD - 607-B Joint Standard for Commercial Building Grounding (Earthing) and Bonding Requirements for Telecommunications, latest edition.
 - 5. NFPA 70 - National Electric Code, latest edition.
 - 6. BICSI - Telecommunications Distribution Methods Manual, latest edition.

1.4 SUBMITTALS

- A. Provide product data for the following:
 - 1. Manufacturers cut sheets, specifications and installation instructions for all products (submit with bid).

PART 2 - PRODUCTS

2.1 WALL-MOUNT BUSBARS

- A. Manufacturers: Subject to compliance with requirements, available manufacturers offering products that may be incorporated into the Work include, but are not limited to, the following:
 - 1. Chatsworth Products, Inc.
- B. Telecommunications Main Grounding Busbar (TMGB)
 - 1. Telecommunications Main Grounding Busbar (TMGB) shall be constructed of .25" (6.4 mm) thick solid copper bar.
 - 2. The busbar shall be 4" (100 mm) high and 20" (510 mm) or longer and shall have multiple attachment points for two-hole grounding lugs.
 - 3. The hole pattern for attaching grounding lugs shall meet the requirements of ANSI-J-STD - 607-A
 - 4. The busbar shall include wall-mount stand-off brackets, assembly screws and insulators creating a 4" (100 mm) standoff from the wall.
 - 5. The busbar shall be UL Listed as grounding and bonding equipment.
- C. Telecommunications Grounding Busbar (TGB)
 - 1. Telecommunications Grounding Busbar (TGB) shall be constructed of .25" (6.4 mm) thick solid copper bar.
 - 2. The busbar shall be 2" (50 mm) high and 12" (300 mm) long and shall have multiple attachment points for two-hole grounding lugs.
 - 3. The hole pattern for attaching grounding lugs shall meet the requirements of ANSI-J-STD - 607-A and shall accept multiple lugs with 5/8" (15.8 mm) and 1" hole centers.
 - 4. The busbar shall include wall-mount stand-off brackets, assembly screws and insulators creating a 4" (100 mm) standoff from the wall.

5. The busbar shall be UL Listed as grounding and bonding equipment.

2.2 BONDING ACCESSORIES

- A. Manufacturers: Subject to compliance with requirements, available manufacturers offering products that may be incorporated into the Work include, but are not limited to, the following:
 1. Chatsworth Products, Inc.
- B. Two Mounting Hole Ground Terminal Block
 1. Ground terminal block shall be made of electroplated tin aluminum extrusion.
 2. Ground terminal block shall accept conductors ranging from #14 AWG through 2/0.
 3. The conductors shall be held in place by two stainless steel set screws.
 4. Ground terminal block shall have two 1/4" (6.4 mm) holes spaced on 5/8" (15.8 mm) centers to allow secure two-bolt attachment to the rack or cabinet.
 5. Ground terminal block shall be UL Listed as a wire connector.
- C. Compression Lugs
 1. Compression lugs shall be manufactured from electroplated tinned copper.
 2. Compression lugs shall have two holes spaced on 5/8" (15.8 mm) or 1" (25.4 mm) centers, as stated below, to allow secure two bolt connections to busbars.
 3. Compression lugs shall be sized to fit a specific size conductor, sizes #6 to 4/0.
 4. Compression lugs shall be UL Listed as wire connectors.
- D. Antioxidant Joint Compound
 1. Oxide inhibiting joint compound for copper-to-copper, aluminum-to-aluminum or aluminum-to-copper connections.
- E. C-Type, Compression Taps
 1. Compression taps shall be manufactured from copper alloy.
 2. Compression taps shall be C-shaped connectors that wrap around two conductors forming an irreversible splice around the conductors; installation requires a hydraulic crimping tool
 3. Compression taps shall be sized to fit specific size conductors, sizes #2 AWG to 4/0.
 4. Compression taps shall be UL Listed.
- F. Pedestal Clamp With Grounding Connector
 1. Pedestal clamp shall be made from electroplated tinned copper or bronze. Installation hardware will be stainless steel.
 2. Pedestal clamps shall be sized to fit a specific size conductor, size #6 and/or 2/0, as stated below.
 3. Pedestal clamp installation hardware shall be sized to attach to round and/or square raised access floor pedestals that are 1-1/8" to 1-3/4" in diameter, as stated below.
 4. Pedestal clamp shall provide straight (in-line) or cross (intersection) support for up to two conductors.
 5. Pedestal clamp shall be UL Listed as grounding and bonding equipment.
- G. Pipe Clamp With Grounding Connector

1. Pipe clamp shall be made from electroplated tinned bronze. Installation hardware will be stainless steel.
 2. Pipe clamp shall be sized to fit up to two conductors ranging in size from #6 to 250 MCM; conductors must be the same size.
 3. Pipe clamp installation hardware shall be sized to attach to pipes, sizes 1" to 6" (.75" to 6.63" in diameter), as stated below.
 4. Pipe clamp shall be UL Listed as grounding and bonding equipment.
- H. Equipment Ground Jumper Kit
1. Kit includes one 24"L insulated ground jumper with a straight two hole compression lug on one end and an L-shaped two hole compression lug on the other end, two plated installation screws, an abrasive pad and a .5 ounce tube of antioxidant joint compound.
 2. Ground conductor is an insulated green/yellow stripe #6 AWG wire
 3. Lugs are made from electroplated tinned copper and have two mounting holes spaces .5" to .625" apart that accept 1/4" screws.
 4. Jumper will be made with UL Listed components

PART 3 - EXECUTION

3.1 INSTALLATION

- A. Wall-Mount Busbars
1. Attach busbars to the wall with appropriate hardware according to the manufacturer's installation instructions.
 2. Conductor connections to the TMGB or TGB shall be made with two-hole bolt-on compression lugs sized to fit the busbar and the conductors.
 3. Each lug shall be attached with stainless steel hardware after preparing the bond according to manufacturer recommendations and treating the bonding surface on the busbar with antioxidant to help prevent corrosion at the bond.
 4. The wall-mount busbar shall be bonded to ground as part of the overall Telecommunications Bonding and Grounding System.
- B. Ground Terminal Block
1. Every rack and cabinet shall be bonded to the TMGB or TGB.
 2. Minimum bonding connection to racks and cabinets shall be made with a rack-mount two-hole ground terminal block sized to fit the conductor and rack and installed according to manufacturer recommendations.
 3. Remove paint between rack/cabinet and terminal block, clean surface and use antioxidant between the rack and the terminal block to help prevent corrosion at the bond.
- C. Pedestal Clamp
1. At minimum, bond every sixth raised access floor pedestal with a minimum #6 AWG conductor to the TMGB or TGB using a pedestal clamp sized to fit the pedestal and the conductor and installed according to the manufacturer's recommendations.
 2. If pedestal clamps are used to construct a signal reference grid, bond the signal reference grid to the TMGB or TGB and bond each rack and/or cabinet to the signal reference grid using a compression tap or similar non-reversible bonding component sized to fit both conductors.

3. Remove paint between the pedestal and pedestal clamp, clean surface and use antioxidant between the pedestal and the clamp to help prevent corrosion at the bond.
 4. Remove insulation from conductors where wires attach to the pedestal clamp.
- D. Pipe Clamp
1. Bond metal pipes located inside the data center computer room with a minimum #6 AWG conductor to the TMGB or TGB using a pipe clamp sized to fit the pipe and the conductor and installed according to the manufacturer's recommendations.
 2. Remove paint between the pipe and pipe clamp, clean surface and use antioxidant between the pipe and the clamp to help prevent corrosion at the bond.
 3. Remove insulation from conductors where wires attach to the pipe clamp.
- E. Equipment Ground Jumper Kit
1. Bond equipment to a vertical rack-mount busbar or ground bar using ground jumper according to the manufacturer's recommendations.
 2. Clean the surface and use antioxidant between the compression lugs on the jumper and the rack-mount busbar or ground bar to help prevent corrosion at the bond.

END OF SECTION

This page is intentionally left blank.

SECTION 27 11 00

COMMUNICATIONS EQUIPMENT ROOM FITTINGS

PART 1 - GENERAL

1.1 RELATED DOCUMENTS

- A. Drawings and general provisions of the Contract, including General and Supplementary Conditions and Division 01 Specification Sections, apply to this Section.
- B. 232123Section 01 81 13 "Sustainable Design Requirements – LEED v4 for Building Design & Construction – New Construction" for sustainable design requirements and detailed sustainable design submittal requirements.
- C. Section 01 74 19 "Construction and Demolition Waste Management and Disposal" for disposal of construction, demolition and packaging waste disposal requirements.

1.2 SUMMARY

- A. Section Includes:
 - 1. Telecommunications mounting elements
 - 2. Backboards.
 - 3. Telecommunications equipment racks and cabinets
 - 4. Telecommunications service entrance pathways
- B. Related Sections:
 - 1. Division 27 Section "Communications Backbone Cabling" for voice and data cabling associated with system panels and devices.
 - 2. Division 27 Section "Communications Horizontal Cabling" for voice and data cabling associated with system panels and devices.
 - 3. Division 28 Section "Conductors and Cables for Electronic Safety and Security" for voice and data cabling associated with system panels and devices.
- C. Sustainable Building Requirements:
 - 1. The Owner requires the Contractor to implement practices and procedures to meet the project's environmental performance goals, which include achieving LEED version 4 **Certified** level Certification. Specific project goals that may impact this area of work include: use of recycled-content materials; use of locally-manufactured materials; use of low-emitting materials; construction waste recycling; and the implementation of a construction indoor air quality management plan. The Contractor shall ensure that the requirements related to these goals, as defined in the Articles below, are implemented to the fullest extent. Substitutions, or other changes to the work proposed by the Contractor or their Subcontractors, shall not be allowed if such changes compromise the aforementioned environmental goals and LEED certification.

1.3 DEFINITIONS

- A. Basket Cable Tray: A fabricated structure consisting of wire mesh bottom and side rails.
- B. BICSI: Building Industry Consulting Service International.
- C. Channel Cable Tray: A fabricated structure consisting of a one-piece, ventilated-bottom or solid-bottom channel not exceeding 6 inches (152 mm) in width.
- D. Ladder Cable Tray: A fabricated structure consisting of two longitudinal side rails connected by individual transverse members (rungs).
- E. LAN: Local area network.
- F. RCDD: BICSI Registered Communications Distribution Designer.
- G. Solid-Bottom or Non-ventilated Cable Tray: A fabricated structure consisting of a bottom without ventilation openings within integral or separate longitudinal side rails.
- H. Trough or Ventilated Cable Tray: A fabricated structure consisting of integral or separate longitudinal rails and a bottom having openings sufficient for the passage of air and using 75 percent or less of the plan area of the surface to support cables.

1.4 PERFORMANCE REQUIREMENTS

- A. Seismic Performance: Floor-mounted cabinets and cable pathways shall withstand the effects of earthquake motions determined according to SEI/ASCE 7.
 - 1. The term "withstand" means "the unit will remain in place without separation of any parts from the device when subjected to the seismic forces specified and the unit will be fully operational after the seismic event."

1.5 SUBMITTALS

- A. Product Data: For each type of product indicated. Include construction details, material descriptions, dimensions of individual components and profiles, and finishes for equipment racks and cabinets. Include rated capacities, operating characteristics, electrical characteristics, and furnished specialties and accessories.
- B. Shop Drawings: For communications equipment room fittings. Include plans, elevations, sections, details, and attachments to other work.
 - 1. Detail equipment assemblies and indicate dimensions, weights, loads, required clearances, method of field assembly, components, and location and size of each field connection.
 - 2. Equipment Racks and Cabinets: Include workspace requirements and access for cable connections.
 - 3. Grounding: Indicate location of grounding bus bar and its mounting detail showing standoff insulators and wall mounting brackets.
- C. Qualification Data: layout technician, installation supervisor, and field inspector.

1.6 QUALITY ASSURANCE

- A. Installer Qualifications: Cabling Installer must have personnel certified by BICSI on staff.

1. Layout Responsibility: Preparation of Shop Drawings shall be under the direct supervision of a BICSI RCDD.
 2. Installation Supervision: Installation shall be under the direct supervision of Registered Technician Level 2 Installer, who shall be present at all times when Work of this Section is performed at Project site.
 3. Field Inspector: Currently registered by BICSI as an RCDD to perform the on-site inspection.
- B. Electrical Components, Devices, and Accessories: Listed and labeled as defined in NFPA 70, by a qualified testing agency, and marked for intended location and application.
- C. Telecommunications Pathways and Spaces: Comply with ANSI/TIA/EIA-569-A.
- D. Grounding: Comply with ANSI-J-STD-607-C.
- E. Labeling of all Telecom components shall be in accordance with/ANSI/TIA/EIA-606(A).
- 1.7 PROJECT CONDITIONS
- A. Environmental Limitations: Do not deliver or install equipment frames and cable trays until spaces are enclosed and weather-tight, wet work in spaces is complete and dry, and work above ceilings is complete.

1.8 COORDINATION

- A. Coordinate layout and installation of communications equipment with Owner's telecommunications and LAN equipment and service suppliers. Coordinate service entrance arrangement with local exchange carrier.
1. Meet jointly with telecommunications and LAN equipment suppliers, local exchange carrier representatives, and Owner and/or their agent to exchange information and agree on details of equipment arrangements and installation interfaces.
 2. Record agreements reached in meetings and distribute them to other participants.
 3. Adjust arrangements and locations of distribution frames, cross-connects, and patch panels in equipment rooms to accommodate and optimize arrangement and space requirements of telephone switch and LAN equipment.
 4. Adjust arrangements and locations of equipment with distribution frames, cross-connects, and patch panels of cabling systems of other communications, electronic safety and security, and related systems that share space in the equipment room.
- B. Coordinate location of power raceways and receptacles with locations of communications equipment requiring electrical power to operate.

PART 2 - PRODUCTS

2.1 CABLING & PATCH PANELS

- A. Cat6A Patch Panels
1. Ortronics OR-PHD6AU48 (2U)
 2. Ortronics OR-60400199 (Strain Relief Bar)

- B. Cat6A 4-pair UTP CMP Cabling
 - 1. Berk-Tek LANmark 10G2 #11085339, CAT6A (Color Blue for IS & Clinical Engineering)

2.2 PATHWAYS

- A. General Requirements: Comply with TIA/EIA-569-A.
- B. Cable Support: NRTL labeled. Cable support brackets shall be designed to prevent degradation of cable performance and pinch points that could damage cable. Cable tie slots fasten cable ties to brackets. Contractors shall note that the use of plastic cable ties is strictly prohibited.
 - 1. Comply with NFPA 70 and UL 2043 for fire-resistant and low-smoke-producing characteristics.
 - 2. Support brackets with cable tie slots for fastening cable ties to brackets.
 - 3. Lacing bars, spools, J-hooks, and D-rings.
 - 4. Straps and other devices.
- C. Ladder Rack, Supports & Accessories:
 - 1. Manufacturers: Subject to compliance with requirements, available manufacturers offering products that may be incorporated into the Work include, but are not limited to, the following:
 - a. CPI
 - 1) 18" Ladder Rack (Black): 10250-718
 - 2) Rung Radius Drop: 12100-712
 - 3) Stringer Radius Drop: 12101-701
 - 4) 6" Cable Retaining Posts: 10596-706
 - 5) 15"W Corner Bracket: 11959-715
 - 6) Provide supports, splice kits and grounding as required to ensure a complete system.
 - 2. Ladder Rack Materials: Metal, suitable for indoors and protected against corrosion.
 - a. Trays shall be provisioned 18" wide.
 - b. Ladder rack shall be manufactured from 3/8" W by 1 1/2" H tubular steel,
 - c. Ladder rack cross members shall be welded in between stringers on 9" centers.
 - d. Finish shall be epoxy-polyester hybrid powder coat – black in color.
 - e. Contractor shall be responsible for furnishing all supports fittings and transition pieces (water falls).
- D. Conduit and Boxes: Comply with requirements in Division 26 Section "Raceway and Boxes for Electrical Systems. Flexible metal conduit shall not be used.
 - 1. Outlet boxes shall be no smaller than 2 inches (50 mm) wide, 3 inches (75 mm) high, and 2-1/2 inches (64 mm) deep.

2.3 BACKBOARDS

- A. Backboards: Plywood, fire-retardant treated, 3/4 by 48 by 96 inches (19 by 1220 by 2440 mm) shall be installed in all telecom spaces as noted and/or required to complete the overall scope of work. Comply with requirements for plywood backing panels specified in Division 06 Section "Rough Carpentry."
- B. All backboards shall be mounted flush on the wall, as detailed in the drawings.

2.4 EQUIPMENT CABINETS, RACKS & ACCESSORIES

- A. Manufacturers: Subject to compliance with requirements, provide products by the following:
1. Chatsworth Products, Inc. (CPI) (IT Racks)
 - a. 19" 2-Post Universal Equipment Rack (Black): 55053-703
 - b. 6"W Double-sided Vertical Cable Manager (Black): 11729-703
 - c. 12"W Double-sided Vertical Cable Manager (Black): TS1000367 (CPI Special Order).
 - d. Rack Installation Kit (Concrete): 40604-001
 - e. 2U Upper Jumper & Transition Tray: 12183-719
 2. Ortronics
 - a. 2U Horizontal Cable Manager:OR-60400426
 3. Great Lakes (Clinical Engineering Cabinets)
 - a. 84"H x 24"W x 36"D Network Cabinet w/ Mesh Front Door, Split Mesh Rear Doors & Vented Top: GL840E-2436MSP
 - b. Casters: 7208-E
 - c. #10-32 Mounting Rails (qty. 2-pair per cabinet): 8405-ES1P
 - d. #10-32 Screws: as required
 4. Rack Solutions
 - a. Adjustable Sliding Shelf: 1USHL-115
- B. General Requirements:
1. Server Cabinets: Freestanding and wall-mounting, modular-steel units designed for telecommunications terminal support and coordinated with dimensions of units to be supported.
 2. Module Dimension: Width compatible with EIA 310 standard, 19-inch (480-mm) panel mounting.
 3. Finish: Manufacturer's standard, baked-polyester powder coat – color black.
- C. Floor-Mounted Racks: Modular-type, aluminum construction.
1. Vertical and horizontal cable management channels, top cable trough, grounding lug, and associated power strips.
 2. Baked-polyester powder coat finish (Black).
- D. Cable Management for Equipment Frames:
1. Metal, ring duct for cabling.
 2. Baked-polyester powder coat finish (Black).
 3. Vertical cable management panels shall have front and rear channels.
 4. Provide horizontal crossover cable manager at the top of each relay rack, with a minimum height of two rack units each. Horizontal manage panel shall be arranged so that one panel is above and below each contractor provided patch panel.

2.5 LABELING

- A. Comply with ANSI/TIA/EIA-606-A and UL 969 for a system of labeling materials, including label stocks, laminating adhesives, and inks used by label printers.
- B. Each new server cabinet and equipment rack shall have custom engraved, phenolic labels, front and rear.

PART 3 - EXECUTION

3.1 ENTRANCE FACILITIES

- A. Contact telecommunications service provider and arrange for installation of demarcation point, protected entrance terminals, and a housing when so directed by service provider.
- B. Install underground pathways complying with recommendations in TIA/EIA-569-A, "Entrance Facilities" Article.

3.2 Install underground entrance pathway complying with Division 26 Section "Raceway and Boxes for Electrical Systems" installation.

- A. Comply with NECA 1.
- B. Comply with BICSI TDMM for layout and installation of communications equipment rooms.
- C. Cable Trays: Comply with NEMA VE 2 and ANSI/TIA/EIA-569-A-7.
- D. Bundle, lace, and train conductors and cables to terminal points without exceeding manufacturer's limitations on bending radii. Install lacing bars and distribution spools.

3.3 FIRESTOPPING

- A. Comply with requirements in Division 07 Section "Penetration Fire-stopping." Comply with ANSI/TIA/EIA-569-A, Annex A, "Fire-stopping."
- B. Comply with BICSI TDMM, "Fire-stopping Systems" Article.

3.4 GROUNDING

- A. Install grounding according to BICSI TDMM, "Grounding, Bonding, and Electrical Protection" Chapter.
- B. Comply with ANSI-J-STD-607-C.
- C. Locate grounding bus bar to minimize the length of bonding conductors. Fasten to wall allowing at least 2-inch (50-mm) clearance behind the grounding bus bar. Connect grounding bus bar with a minimum No. 4 AWG grounding electrode conductor from grounding bus bar to suitable electrical building ground.
- D. Bond metallic equipment to the grounding bus bar, using not smaller than No. 6 AWG equipment grounding conductor.
 - 1. Bond the shield of shielded cable to the grounding bus bar in communications rooms and spaces.

3.5 IDENTIFICATION

- A. Identify system components, wiring, and cabling complying with ANSI/TIA/EIA-606-A. Comply with requirements in Division 26 Section "Identification for Electrical Systems." Comply with requirements in Division 09 Section "Interior Painting" for painting backboards. For fire-resistant plywood, do not paint over manufacturer's label.

- B. See Division 27 Section "Communications Horizontal Cabling" for additional identification requirements. See Evaluations for discussion of ANSI/TIA/EIA standard as it applies to this Section. Paint and label colors for equipment identification shall comply with ANSI/TIA/EIA-606-A for Class 3 level of administration including optional identification requirements of this standard.
- C. Labels shall be preprinted or computer-printed type.

END OF SECTION

This page is intentionally left blank.

SECTION 27 13 00

COMMUNICATIONS BACKBONE CABLING

PART 1 - GENERAL

1.1 RELATED DOCUMENTS

- A. Drawings and general provisions of the Contract, including General and Supplementary Conditions and Division 01 Specification Sections, apply to this Section.
- B. 232123Section 01 81 13 "Sustainable Design Requirements – LEED v4 for Building Design & Construction – New Construction" for sustainable design requirements and detailed sustainable design submittal requirements.
- C. Section 01 74 19 "Construction and Demolition Waste Management and Disposal" for disposal of construction, demolition and packaging waste disposal requirements.

1.2 SUMMARY

- A. Section Includes:
 - 1. Pathways
 - 2. UTP cable
 - 3. Optical fiber cabling
 - 4. Cable connecting hardware, patch panels, and cross-connects
 - 5. Cabling identification products
- B. Related Sections:
 - 1. Division 28 Section "Conductors and Cables for Electronic Safety and Security" for voice and data cabling associated with system panels and devices.
- C. Sustainable Building Requirements:
 - 1. The Owner requires the Contractor to implement practices and procedures to meet the project's environmental performance goals, which include achieving LEED version 4 **Certified** level Certification. Specific project goals that may impact this area of work include: use of recycled-content materials; use of locally-manufactured materials; use of low-emitting materials; construction waste recycling; and the implementation of a construction indoor air quality management plan. The Contractor shall ensure that the requirements related to these goals, as defined in the Articles below, are implemented to the fullest extent. Substitutions, or other changes to the work proposed by the Contractor or their Subcontractors, shall not be allowed if such changes compromise the aforementioned environmental goals and LEED certification.

1.3 DEFINITIONS

- A. BICSI: Building Industry Consulting Service International.

- B. Cross-Connect: A facility enabling the termination of cable elements and their interconnection or cross-connection.
- C. EMI: Electromagnetic interference.
- D. IDC: Insulation displacement connector.
- E. LAN: Local area network.
- F. RCDD: Registered Communications Distribution Designer.
- G. UTP: Unshielded twisted pair.

1.4 BACKBONE CABLING DESCRIPTION

- A. Backbone cabling system shall provide interconnections between communications equipment rooms, main terminal space, and entrance facilities in the telecommunications cabling system structure. Cabling system consists of backbone cables, intermediate and main cross-connects, mechanical terminations, and patch cords or jumpers used for backbone-to-backbone cross-connection.
- B. Backbone cabling cross-connects may be located in communications equipment rooms or at entrance facilities. Bridged taps and splitters shall not be used as part of backbone cabling.
- C. UTP Backbone Infrastructure – Contractors shall supply and install, in the pair counts as denoted on the provided drawings, all copper UTP backbone riser cabling between each identified Telecom Room and the Main Server Room (see drawings for exact location). Contractors shall be responsible for providing and installing all components necessary to complete this scope of work. This work shall include but not be limited to all: termination hardware, cable supports, cable management (troughs, D-Rings or Velcro), cross-connect wiring, or any additional hardware needed for routing backbone cabling between the identified locations. (Number of pairs shall be provided by MMC).
- D. Fiber Optic Backbone Infrastructure – Contractors shall supply and install Single-mode 12-Strand MIC Tight-Buffered, Dielectric Armored Plenum-Rated riser cabling between each identified Telecom Room and the Main Server Room. Contractors shall be responsible for providing and installing all components necessary to complete this scope of work, this includes but is not limited to all, termination hardware, connector panel housings, cable supports and all cable management hardware. (Number of strands shall be provided by MMC).

1.5 PERFORMANCE REQUIREMENTS

- A. General Performance: Backbone cabling system shall comply with transmission standards in ANSI/TIA/EIA-568-B.1, when tested according to test procedures of this standard.

1.6 SUBMITTALS

- A. Product Data: For each type of product indicated.
 - 1. Submit manufacturers' product data sheets for all material and equipment products proposed in bid. Only specified or accepted manufacturers or suppliers shall appear in the product data submittal.

2. Where substitutions or alternates are requested for any specified manufacturer or product, contractors shall submit complete documentation for the proposed product, including complete product data/catalog sheets, performance/engineering reports and any additional information that may be pertinent to the approval of this product.
- B. Shop Drawings:
1. System Labeling Schedules: Electronic copy of labeling schedules, in software and format selected by Owner.
 2. System Labeling Schedules: Electronic copy of labeling schedules that are part of the cabling and asset identification system of the software.
 3. Cabling administration drawings and printouts.
 4. Wiring diagrams to show typical wiring schematics including the following:
 - a. Cross-connects.
 - b. Patch panels.
 - c. Patch cords.
 5. Cross-connects and patch panels. Detail mounting assemblies, and show elevations and physical relationship between the installed components.
 6. Pathway (i.e. J-hook/or tray) layouts, showing route to scale, with relationship between the pathway and any adjacent structural, electrical, and mechanical elements. Include the following:
 - a. Vertical and horizontal offsets and transitions.
 - b. Clearances for access above and to side of cable trays.
 - c. Vertical elevation of cable trays above the floor or bottom of ceiling structure.
 - d. Load calculations to show dead and live loads as not exceeding manufacturer's rating for tray and its support elements.
 7. Shop drawings shall be submitted (10) days prior to start of work and prior to ordering any material. Shop drawings shall consist of (1) set of reproducible drawings and (3) copies of all drawings, diagrams and/or manufacturer data in accordance with the contract documentation.
 8. As-built documentation shall be provided at the completion of installation. As-built documentation shall include all floor plan views, elevations drawings, cable termination and cross connect schedules. Drawing sets shall consist of (1) reproducible set (velum and electronic) and (3) hard copies. All Schedules shall include (1) hard copy set and (1) electronic copies.
 9. Contractors shall note that any electronic media sets that are to be turned in at the completion of the project should be coordinated with the end-user to ensure proper formatting and/or software compatibility.
- C. Qualification Data: For layout technician, installation supervisor, and Project manager.
- D. Source quality-control reports.
- E. Field quality-control reports.
- F. Maintenance Data: For splices and connectors to include in maintenance manuals.
- G. Software and Firmware Operational Documentation:
1. Software operating and upgrade manuals.
 2. Program Software Backup: On magnetic media or compact disk, complete with data files.

3. Device address list.
4. Printout of software application and graphic screens.

1.7 QUALITY ASSURANCE

- A. Installer Qualifications: Cabling Installer must have personnel certified by BICSI on staff is recommended.
 1. Layout Responsibility: Preparation of Shop Drawings, Cabling Administration Drawings, and field testing program development by a certified designer.
 2. Installation Supervision: Installation shall be under the direct supervision of Level 2 Installer, who shall be present at all times when Work of this Section is performed at Project site.
- B. Electrical Components, Devices, and Accessories: Listed and labeled as defined in NFPA 70, by a qualified testing agency, and marked for intended location and application.
- C. Telecommunications Pathways and Spaces: Comply with ANSI/TIA/EIA-569-A.
- D. Grounding: Comply with ANSI-J-STD-607-C.

1.8 DELIVERY, STORAGE, AND HANDLING

- A. Test cables upon receipt at Project site.
 1. Test optical fiber cable to determine the continuity of the strands end to end. Use optical fiber flashlight or optical loss test set.
 2. Test optical fiber cable while on reels. Use an optical time domain reflectometer to verify the cable length and locate cable defects, splices, etc., including the loss value of each. Retain test data and include the record in maintenance data.
 3. Test each pair of UTP cable for open and short circuits.
- B. Delivery and Storage
 1. Contractor shall be responsible for the coordination and receipt of any job related material being shipped to the site and also for ensuring the proper storage and safe guard of this material. Coordination of delivery shall include direct communications with the General Contractor, the end-user/facilities group and/or building owner (as necessary) to ensure proper scheduling and delivery requirements.

1.9 PROJECT CONDITIONS

- A. Environmental Limitations: Do not deliver or install cables and connecting materials until wet work in spaces is complete and dry, and temporary HVAC system is operating and maintaining ambient temperature and humidity conditions at occupancy levels during the remainder of the construction period.

1.10 COORDINATION

- A. Coordinate layout and installation of telecommunications pathways and cabling with Owner's telecommunications and LAN equipment and service suppliers.

1.11 EXTRA MATERIALS

- A. Furnish extra materials that match products installed and that are packaged with protective covering for storage and identified with labels describing contents.
 - 1. Patch-Panel Units: One of each type.
 - 2. Connecting Blocks: One of each type.

1.12 WARRANTY

- A. Cabling Contractor shall have the ability to extend to end-user a minimum warranty period of 20 years for the system(s) they intend to install. This warranty shall certify that the installation will be free from defects in performance and workmanship, as well as meet or exceed all ANSI/TIA/EIA performance requirements. Contractor will be required to submit all pre-project and post project documentation including test documentation and registration forms necessary for system coverage under this program.
- B. System coverage shall but is not limited to the following components.
 - 1. Cabling components.
 - 2. Connecting Hardware.
 - 3. Connectors.
 - 4. Jacks/Outlets.

PART 2 - PRODUCTS

2.1 UTP CABLE

- A. Manufacturers: Subject to compliance with requirements, provide products by one of the following:
 - 1. Berk-Tek: 25-Pair Category 3 Plenum-Rated
 - a. Gray (10032111)
 - 2. Berk-Tek: 100-Pair Category 3 Plenum-Rated
 - a. Gray (10032113)
- B. Description: 100-ohm UTP:
 - 1. Comply with ICEA S-90-661 for mechanical properties.
 - 2. Comply with ANSI/TIA/EIA-568-B.1 for performance specifications.
 - 3. Comply with ANSI/TIA/EIA-568-B.2, Category 3.
 - 4. Listed and labeled by an NRTL acceptable to authorities having jurisdiction as complying with UL 444 and NFPA 70 for the following type (or equivalent).
 - 5. Type requirements in subparagraphs below are minimum requirements and may be revised to suit Project. Retain options if "permitted substitutions," as defined in NFPA 70, are appropriate for this Project.
 - 6. Communications Plenum Cable: Type CMP

2.2 UTP CABLE HARDWARE

- A. Manufacturers: Subject to compliance with requirements, provide products by one of the following:
 - 1. Ortronics:
 - a. Flat 48-Port CAT6A Patch Panel (OR-PHD6AU48)

- B. General Requirements for Cable Connecting Hardware: Comply with ANSI/TIA/EIA-568-B.2, IDC type, with modules designed for punch-down caps or tools. Cables shall be terminated with connecting hardware of same category or higher.

2.3 COAXIAL CABLE

- A. Manufacturers: Subject to compliance with requirements, provide products by the following:
 - 1. Commscope:
 - a. Quad-shielded Series-11 Plenum-Rated Coaxial Cable: 2287K
- B. Description:
 - 1. 3GHz RG11 75-Ohm
 - 2. 14 AWG copper-clad steel wire
- C. Jacket:
 - 1. Jacket Color: Cream.
 - 2. Imprinted with cable name, type, and aggregate length at regular intervals not to exceed 40 inches (1000 mm).

2.4 OPTICAL FIBER CABLE

- A. Manufacturers: Subject to compliance with requirements, provide products by the following:
 - 1. Corning:
 - a. 12-Strand MIC Tight-Buffered, Dielectric Armored Plenum-Rated Single-mode Cable: 0XXE88-33131-D3
XX=Strand Count
- B. Description: Single-mode, 9/125-micrometer (OS2), dielectric/nonconductive armored, tight buffer, optical fiber cable.
 - 1. Comply with ICEA S-83-596 for mechanical properties.
 - 2. Comply with ANSI/TIA/EIA-568-B.3 for performance specifications.
 - 3. Comply with ANSI/TIA/EIA-492AAAA-B for detailed specifications.
 - 4. Listed and labeled as complying with UL 444, UL 1651, and NFPA 70 for the following types (or equivalent).
 - 5. Plenum Rated, Nonconductive: Type NFPA 262.
 - 6. Maximum Attenuation: 0.65 dB/km at 1310 nm; 0.65 dB/km at 1383 nm; 0.5 dB/km at 1550 nm
- C. Jacket:
 - 1. Jacket Color: Yellow
 - 2. Cable cordage jacket, fiber, unit, and group color shall be according to ANSI/TIA/EIA-598-B.
 - 3. Imprinted with fiber count, fiber type, and aggregate length at regular intervals not to exceed 40 inches (1000 mm).

2.5 OPTICAL FIBER CABLE TERMINATION HARDWARE

- A. Manufacturers: Subject to compliance with requirements, provide products by one of the following:
 - 1. Corning:

- a. 1U Rack-mount Fiber Enclosure (CCH-01U)
 - b. 2U Rack-mount Fiber Enclosure (CCH-02U)
 - c. SC Single-mode Connector Panel (CCH-CP12-59)
 - d. SC Single-mode Connector (900-200-41)
- B. Cross-Connects and Patch Panels: Modular panels housing multiple-numbered, duplex cable connectors.
1. Number of Connectors per Field: One for each fiber of cable or cables assigned to field, plus spares and blank positions adequate to suit specified expansion criteria.
- C. Patch Cords: Factory-made, dual-fiber cables in 36-inch (900-mm) lengths. Exact length & quantity to be field coordinated with client.
- D. Cable Connecting Hardware:
1. Comply with Optical Fiber Connector Intermateability Standards (FOCIS) specifications of TIA/EIA-604-2, TIA/EIA-604-3-A, and TIA/EIA-604-12. Comply with TIA/EIA-568-B.3.
 2. Quick-connect, simplex and duplex, Type SC connectors. Insertion loss not more than 0.75 dB.

2.6 GROUNDING

- A. Comply with requirements in Division 26 Section "Grounding and Bonding for Electrical Systems." for grounding conductors and connectors.
- B. Comply with ANSI-J-STD-607-B.

2.7 IDENTIFICATION PRODUCTS

- A. Comply with ANSI/TIA/EIA-606-A and UL 969 for a system of labeling materials, including label stocks, laminating adhesives, and inks used by label printers.

2.8 SOURCE QUALITY CONTROL

- A. Testing Agency: Engage a qualified testing agency to evaluate cables.
- B. Factory test cables on reels according to ANSI/TIA/EIA-568-B.1.
- C. Factory test UTP cables according to ANSI/TIA/EIA-568-B.2.
- D. Factory test multimode optical fiber cables according to ANSI/TIA/EIA-526-14-A and ANSI/TIA/EIA-568-B.3.
- E. Cable will be considered defective if it does not pass tests and inspections.
- F. Prepare test and inspection reports.

PART 3 - EXECUTION

3.1 ENTRANCE FACILITIES

- A. Coordinate backbone cabling with the protectors and demarcation point provided by communications service provider.

3.2 WIRING METHODS

- A. Wiring Method: Install cables in raceways and cable trays except within consoles, cabinets, desks, and counters and except in accessible ceiling spaces, in attics, and in gypsum board partitions where unenclosed wiring method may be used. Conceal raceway and cables except in unfinished spaces.
 - 1. Install plenum cable in environmental air spaces, including plenum ceilings.
 - 2. Comply with requirements for raceways and boxes specified in Division 26 Section "Raceway and Boxes for Electrical Systems."
- B. Wiring Method: Conceal conductors and cables in accessible ceilings, walls, and floors where possible.
- C. Wiring within Enclosures: Bundle, lace, and train cables within enclosures. Connect to terminal points with no excess and without exceeding manufacturer's limitations on bending radii. Provide and use lacing bars and distribution spools.

3.3 INSTALLATION OF PATHWAYS

- A. Cable Trays: Comply with NEMA VE 2 and ANSI/TIA/EIA-569-A.
- B. Comply with requirements for demarcation point, pathways, cabinets, and racks specified in Division 27 Section "Communications Equipment Room Fittings." Drawings indicate general arrangement of pathways and fittings.
- C. Comply with ANSI/TIA/EIA-569-A for pull-box sizing and length of conduit and number of bends between pull points.
- D. Comply with requirements in Division 26 Section "Raceway and Boxes for Electrical Systems" for installation of conduits and wireways.
- E. Install manufactured conduit sweeps and long-radius elbows whenever possible.
- F. Pathway Installation in Communications Equipment Rooms:
 - 1. Position conduit ends adjacent to a corner on backboard where a single piece of plywood is installed, or in the corner of room where multiple sheets of plywood are installed around perimeter walls of room.
 - 2. Install cable trays to route cables if conduits cannot be located in these positions.
 - 3. Secure conduits to backboard when entering room from overhead.
 - 4. Extend conduits 3 inches (76 mm)] above finished floor.
 - 5. Install metal conduits with grounding bushings and connect with grounding conductor to grounding system.
 - 6. Contracts shall provide any additional transitional fittings to properly route and manage all cabling to its final termination point.
- G. Backboards: Install backboards with 96-inch (2440-mm) dimension vertical. Butt adjacent sheets tightly, and form smooth gap-free corners and joints.

3.4 INSTALLATION OF CABLES

- A. Comply with NECA 1.
- B. General Requirements for Cabling:
 - 1. Comply with ANSI/TIA/EIA-568-B.1.
 - 2. Comply with BICSI ITSIM, Ch. 6, "Cable Termination Practices."
 - 3. Install 110-style IDC termination hardware unless otherwise indicated.

4. Terminate all conductors; no cable shall contain unterminated elements. Make terminations only at indicated outlets, terminals, cross-connects, and patch panels.
 5. Cables may not be spliced. Secure and support cables at intervals not exceeding 30 inches (760 mm) and not more than 6 inches (150 mm) from cabinets, boxes, fittings, outlets, racks, frames, and terminals.
 6. Install lacing bars to restrain cables, to prevent straining connections, and to prevent bending cables to smaller radii than minimums recommended by manufacturer.
 7. Bundle, lace, and train conductors to terminal points without exceeding manufacturer's limitations on bending radii, but not less than radii specified in BICSI ITSIM, "Cabling Termination Practices" Chapter. Use lacing bars and distribution spools.
 8. Do not install bruised, kinked, scored, deformed, or abraded cable. Do not splice cable between termination, tap, or junction points. Remove and discard cable if damaged during installation and replace it with new cable.
 9. Cold-Weather Installation: Bring cable to room temperature before dereeling. Heat lamps shall not be used for heating.
 10. In the communications equipment room, install an 8-foot- (3-m-) long service loop on each end of cable.
 11. Pulling Cable: Comply with BICSI ITSIM, Ch. 4, "Pulling Cable." Monitor cable pull tensions.
- C. UTP Cable Installation:
1. Comply with ANSI/TIA/EIA-568-B.2.
 2. Do not untwist UTP cables more than **1/4 inch (6 mm)** from the point of termination to maintain cable geometry.
- D. Optical Fiber Cable Installation:
1. Comply with ANSI/TIA/EIA-568-B.3.
 2. Cable may be terminated on connecting hardware that is rack or cabinet mounted.
- E. Open-Cable Installation:
1. Install cabling with horizontal and vertical cable guides in telecommunications spaces with terminating hardware and interconnection equipment.
 2. Suspend UTP cable not in a wireway or pathway, a minimum of 8 inches (200 mm) above ceilings by cable supports not more than 60 inches (5' ft.) on centers.
 3. Cable shall not be run through structural members or in contact with pipes, ducts, or other potentially damaging items.
- F. Group connecting hardware for cables into separate logical fields.
- G. Separation from EMI Sources:
1. Comply with BICSI TDMM and ANSI/TIA/EIA-569-A recommendations for separating unshielded copper voice and data communication cable from potential EMI sources, including electrical power lines and equipment.
 2. Separation between open communications cables or cables in nonmetallic raceways and unshielded power conductors and electrical equipment shall be as follows:
 - a. Electrical Equipment Rating Less Than 2 kVA: A minimum of 5 inches (127 mm).
 - b. Electrical Equipment Rating between 2 and 5 kVA: A minimum of 12 inches (300 mm).

- c. Electrical Equipment Rating More Than 5 kVA:
A minimum of 24 inches (610 mm).
3. Separation between communications cables in grounded metallic raceways and unshielded power lines or electrical equipment shall be as follows:
 - a. Electrical Equipment Rating Less Than 2 kVA:
A minimum of 2-1/2 inches (64 mm).
 - b. Electrical Equipment Rating between 2 and 5 kVA: A minimum of 6 inches (150 mm).
 - c. Electrical Equipment Rating More Than 5 kVA:
A minimum of 12 inches (300 mm).
4. Separation between communications cables in grounded metallic raceways and power lines and electrical equipment located in grounded metallic conduits or enclosures shall be as follows:
 - a. Electrical Equipment Rating Less Than 2 kVA:
No requirement.
 - b. Electrical Equipment Rating between 2 and 5 kVA: A minimum of 3 inches (76 mm).
 - c. Electrical Equipment Rating More Than 5 kVA:
A minimum of 6 inches (150 mm).
5. Separation between Communications Cables and Electrical Motors and Transformers, 5 kVA or HP and Larger: A minimum of 48 inches (1200 mm).
6. Separation between Communications Cables and Fluorescent Fixtures: A minimum of 5 inches (127 mm).

3.5 FIRESTOPPING

- A. Comply with requirements in Division 07 Section "Penetration Firestopping". Comply with ANSI/TIA/EIA-569-A, Annex A, "Firestopping."
- B. Comply with BICSI TDMM, "Firestopping Systems" Article.

3.6 GROUNDING

- A. Install grounding according to BICSI TDMM, "Grounding, Bonding, and Electrical Protection" Chapter.
- B. Comply with ANSI-J-STD-607-B.
- C. Locate grounding bus bar to minimize the length of bonding conductors. Fasten to wall allowing at least 2-inch (50-mm) clearance behind the grounding bus bar. Connect grounding bus bar with a minimum No. 4 AWG grounding electrode conductor from grounding bus bar to suitable electrical building ground.
- D. Bond metallic equipment to the grounding bus bar, using not smaller than No. 6 AWG equipment grounding conductor.

3.7 IDENTIFICATION

- A. Identify system components, wiring, and cabling complying with ANSI/TIA/EIA-606-A. Comply with requirements for identification specified in Division 26 Section "Identification for Electrical Systems."
 1. Administration Class: 3.
 2. Color-code cross-connect fields and apply colors to voice and data service backboards, connections, covers, and labels.

- B. Comply with requirements in Division 09 Section "Interior Painting" for painting backboards. For fire-resistant plywood, do not paint over manufacturer's label.
- C. See Division 27 Section "Communications Horizontal Cabling" for additional identification requirements. See Evaluations for discussion about TIA/EIA standard as it applies to this Section. Paint and label colors for equipment identification shall comply with ANSI/TIA/EIA-606-A for Class 3 level of administration including optional identification requirements of this standard.
- D. Comply with requirements in Division 27 Section "Communications Horizontal Cabling" for cable and asset management software.
- E. Cable Schedule: Install in a prominent location in each equipment room and Telecom Room. List incoming and outgoing cables and their designations, origins, and destinations. Protect with rigid frame and clear plastic cover. Furnish an electronic copy of final comprehensive schedules for Project.
- F. Cabling Administration Drawings: Show building floor plans with cabling administration-point labeling. Identify labeling convention and show labels for telecommunications rooms, backbone pathways and cables, terminal hardware and positions, horizontal cables, work areas and workstation terminal positions, grounding buses and pathways, and equipment grounding conductors.
- G. Cable and Wire Identification:
 - 1. Label each cable within 4 inches (100 mm) of each termination and tap, where it is accessible in a cabinet or junction or outlet box, and elsewhere as indicated.
 - 2. Each wire connected to building-mounted devices is not required to be numbered at device if color of wire is consistent with associated wire connected and numbered within panel or cabinet.
 - 3. Exposed Cables and Cables in Cable Trays and Wire Troughs: Label each cable at intervals not exceeding 25 feet (4.5 m).
 - 4. Label each terminal strip and screw terminal in each cabinet, rack, or panel.
 - a. Individually number wiring conductors connected to terminal strips and identify each cable or wiring group being extended from a panel or cabinet to a building-mounted device with name and number of particular device as shown.
 - b. Label each unit and field within distribution racks and frames.
 - 5. Identification within Connector Fields in Equipment Rooms and Wiring Closets: Label each connector and each discrete unit of cable-terminating and connecting hardware. Where similar jacks and plugs are used for both voice and data communication cabling, use a different color for jacks and plugs of each service.
- H. Labels shall be preprinted or computer-printed type with printing area and font color that contrasts with cable jacket color but still complies with requirements in TIA/EIA 606-A, for the following:
 - 1. For cables, use flexible vinyl or polyester that flexes as cables are bent.

3.8 FIELD QUALITY CONTROL

- A. Perform tests and inspections.

- B. Tests and Inspections:
1. Visually inspect UTP and optical fiber jacket materials for NRTL certification markings. Inspect cabling terminations in communications equipment rooms for compliance with color-coding for pin assignments, and inspect cabling connections for compliance with ANSI/TIA/EIA-568-B.1.
 2. Visually inspect cable placement, cable termination, grounding and bonding, equipment and patch cords, and labeling of all components.
 3. Test UTP copper cabling for DC loop resistance, shorts, opens, intermittent faults, and polarity between conductors. Test operation of shorting bars in connection blocks. Test cables after termination but not cross-connection.
 - a. Test instruments shall meet or exceed applicable requirements in ANSI/TIA/EIA-568-B.2. Perform tests with a tester that complies with performance requirements in "Test Instruments (Normative)" Annex, complying with measurement accuracy specified in "Measurement Accuracy (Informative)" Annex. Use only test cords and adapters that are qualified by test equipment manufacturer for channel or link test configuration.
 4. Optical Fiber Cable Tests:
 - a. Test instruments shall meet or exceed applicable requirements in ANSI/TIA/EIA-568-B.1. Use only test cords and adapters that are qualified by test equipment manufacturer for channel or link test configuration.
 - b. Link End-to-End Attenuation Tests:
 - 1) Horizontal and multimode backbone link measurements: Test at 850 or 1300 nm in 1 direction according to ANSI/TIA/EIA-526-14-A, Method B, One Reference Jumper.
 - 2) Attenuation test results for backbone links shall be less than 2.0 dB. Attenuation test results shall be less than that calculated according to equation in ANSI/TIA/EIA-568-B.1.
- C. Data for each measurement shall be documented. Data for submittals shall be printed in a summary report that is formatted similar to Table 10.1 in BICSI TDMM, or transferred from the instrument to the computer, saved as text files, and printed and submitted.
- D. Remove and replace cabling where test results indicate that they do not comply with specified requirements.
- E. End-to-end cabling will be considered defective if it does not pass tests and inspections.
- F. Prepare test and inspection reports.

END OF SECTION

SECTION 27 15 00

COMMUNICATIONS HORIZONTAL CABLING

PART 1 - GENERAL

1.1 RELATED DOCUMENTS

- A. Drawings and general provisions of the Contract, including General and Supplementary Conditions and Division 01 Specification Sections, apply to this Section.
- B. 232123Section 01 81 13 "Sustainable Design Requirements – LEED v4 for Building Design & Construction – New Construction" for sustainable design requirements and detailed sustainable design submittal requirements.
- C. Section 01 74 19 "Construction and Demolition Waste Management and Disposal" for disposal of construction, demolition and packaging waste disposal requirements.

1.2 SUMMARY

- A. Section Includes:
 - 1. Pathways
 - 2. UTP cabling
 - 3. Cable connecting hardware, patch panels, and cross-connects
 - 4. Telecommunications outlet/connectors
 - 5. Cabling system identification products
 - 6. Cable management system
- B. Related Sections:
 - 1. Section 270002 – "Unit Pricing" for voice and data cabling.
 - 2. Section 270526 – "Grounding & Bonding for Communications Systems"
 - 3. Section 271300 – "Communications Backbone Cabling"
- C. Sustainable Building Requirements:
 - 1. The Owner requires the Contractor to implement practices and procedures to meet the project's environmental performance goals, which include achieving LEED version 4 **Certified** level Certification. Specific project goals that may impact this area of work include: use of recycled-content materials; use of locally-manufactured materials; use of low-emitting materials; construction waste recycling; and the implementation of a construction indoor air quality management plan. The Contractor shall ensure that the requirements related to these goals, as defined in the Articles below, are implemented to the fullest extent. Substitutions, or other changes to the work proposed by the Contractor or their Subcontractors, shall not be allowed if such changes compromise the aforementioned environmental goals and LEED certification.

1.3 DEFINITIONS

- A. Basket Cable Tray: A fabricated structure consisting of wire mesh bottom and side rails.

- B. BICSI: Building Industry Consulting Service International.
- C. Channel Cable Tray: A fabricated structure consisting of a one-piece, ventilated-bottom or solid-bottom channel.
- D. Consolidation Point: A location for interconnection between horizontal cables extending from building pathways and horizontal cables extending into furniture pathways.
- E. Cross-Connect: A facility enabling the termination of cable elements and their interconnection or cross-connection.
- F. EMI: Electromagnetic interference.
- G. IDC: Insulation displacement connector.
- H. Ladder Cable Tray: A fabricated structure consisting of two longitudinal side rails connected by individual transverse members (rungs).
- I. LAN: Local area network.
- J. MUTOA: Multiuser telecommunications outlet assembly, a grouping in one location of several telecommunications outlet/connectors.
- K. Outlet/Connectors: A connecting device in the work area on which horizontal cable or outlet cable terminates.
- L. RCDD: Registered Communications Distribution Designer.
- M. Solid-Bottom or Non-ventilated Cable Tray: A fabricated structure consisting of longitudinal side rails and a bottom without ventilation openings.
- N. Trough or Ventilated Cable Tray: A fabricated structure consisting of longitudinal side rails and a bottom having openings for the passage of air.
- O. UTP: Unshielded twisted pair.

1.4 HORIZONTAL CABLING DESCRIPTION

- A. Horizontal cable and its connecting hardware provide the means of transporting signals between the telecommunications outlet/connector and the horizontal cross-connect located in the communications equipment room. This cabling and its connecting hardware are called "permanent link," a term that is used in the testing protocols.
 - 1. Horizontal cabling shall contain no more than one transition point or consolidation point between the horizontal cross-connect and the telecommunications outlet/connector.
 - 2. Bridged taps and splices shall not be installed in the horizontal cabling.
- B. The maximum allowable horizontal cable length is 295 feet (90 m). This maximum allowable length does not include an allowance for the length of 16 feet (4.9 m) to the workstation equipment. The maximum allowable length does not include an allowance for the length of 16 feet (4.9 m) in the horizontal cross-connect.
- C. UTP Horizontal Cabling Infrastructure – Contractors shall supply and install to each identified workstation area the quantities of cabling as denoted by the drawing package. Contractors shall note that under this scope of work there will be several different types of workstation outlets based on their exact location and the intended users of this system.

1.5 PERFORMANCE REQUIREMENTS

- A. General Performance: Horizontal cabling system shall comply with transmission standards in ANSI/TIA/EIA-568-B.1, when tested according to test procedures of this standard.

1.6 SUBMITTALS

- A. Product Data: For each type of product indicated.
1. Submit manufacturers' product data sheets for all material and equipment products proposed in bid. Only specified or accepted manufacturers or suppliers shall appear in the product data submittal.
 2. Where substitutions or alternates are requested for any specified manufacturer or product, contractor shall submit complete documentation for the proposed product, including complete product data/catalog sheets, performance/engineering reports and any additional information that may be pertinent to the approval of this product.
- B. Shop Drawings:
1. System Labeling Schedules: Electronic copy of labeling schedules, in software and format selected by Owner.
 2. System Labeling Schedules: Electronic copy of labeling schedules that are part of the cabling and asset identification system of the software.
 3. Cabling administration drawings and printouts.
 4. Wiring diagrams to show typical wiring schematics, including the following:
 - a. Cross-connects.
 - b. Patch panels.
 - c. Patch cords.
 5. Cross-connects and patch panels. Detail mounting assemblies, and show elevations and physical relationship between the installed components.
 6. Cable tray layout, showing cable tray route to scale, with relationship between the tray and adjacent structural, electrical, and mechanical elements. Include the following:
 - a. Vertical and horizontal offsets and transitions.
 - b. Clearances for access above and to side of cable trays.
 - c. Vertical elevation of cable trays above the floor or bottom of ceiling structure.
 - d. Load calculations to show dead and live loads as not exceeding manufacturer's rating for tray and its support elements.
 7. Shop drawings shall be submitted (10) days prior to start of work and prior to ordering any material. Shop drawings shall consist of (1) set of reproducible drawings and (3) copies of all drawings, diagrams and/or manufacturer data in accordance with the contract documentation.
 8. As-built documentation shall be provided at the completion of installation. As-built documentation shall include all floor plan views, elevations drawings, cable termination and cross connect schedules. Turnover sets shall consist of (1) reproducible set and (3) copies. Schedules shall include (1) hard copy set and (1) electronic.
- C. Samples: For workstation outlets, jacks, jack assemblies, and faceplates, one for each size and outlet configuration for color selection and evaluation of technical features.

- D. Qualification Data: For layout technician, installation supervisor, and Project Manager.
- E. Source quality-control reports.
- F. Field quality-control reports.
- G. Maintenance Data: For splices and connectors to include in maintenance manuals.
- H. Software and Firmware Operational Documentation:
 - 1. Software operating and upgrade manuals.
 - 2. Program Software Backup: On magnetic media or compact disk, complete with data files.
 - 3. Device address list.
 - 4. Printout of software application and graphic screens.

1.7 QUALITY ASSURANCE

- A. Installer Qualifications: Cabling Installer must have personnel certified by BICSI on staff.
 - 1. Layout Responsibility: Preparation of Shop Drawings, Cabling Administration Drawings, and field testing program.
 - 2. Installation Supervision: Installation shall be under the direct supervision of Level 2 Installer, who shall be present at all times when Work of this Section is performed at Project site.
- B. Electrical Components, Devices, and Accessories: Listed and labeled as defined in NFPA 70, by a qualified testing agency, and marked for intended location and application.
- C. Telecommunications Pathways and Spaces: Comply with ANSI/TIA/EIA-569-A.
- D. Grounding: Comply with ANSI-J-STD-607-B.

1.8 PROJECT CONDITIONS

- A. Environmental Limitations: Do not deliver or install cables and connecting materials until wet work in spaces is complete and dry, and temporary HVAC system is operating and maintaining ambient temperature and humidity conditions at occupancy levels during the remainder of the construction period.
- B. Delivery and Storage
 - 1. Contractor shall be responsible for the coordination and receipt of any job related material being shipped to the site and also for ensuring the proper storage and safe guard of this material. Coordination of delivery shall include direct communications with the General Contractor, the end-user/facilities group and or building owner (as necessary) to ensure proper scheduling and delivery requirements.

1.9 COORDINATION

- A. Coordinate layout and installation of telecommunications pathways and cabling with Owner's telecommunications and LAN equipment and service suppliers.
- B. Coordinate telecommunications outlet/connector locations with location of power receptacles at each work area.

1.10 EXTRA MATERIALS

- A. Furnish extra materials that match products installed and that are packaged with protective covering for storage and identified with labels describing contents.
 - 1. Patch-Panel Units: One of each type.
 - 2. Connecting Blocks: One of each type.
 - 3. Device Plates: One of each type.
 - 4. Multiuser Telecommunications Outlet Assemblies: One of each type.

1.11 WARRANTY

- A. Cabling Contractor shall have the ability to extend to end-user a minimum warranty period of 20-years for the system(s) they intend to install. This warranty shall certify that the installation will be free from defects in performance and workmanship, as well as meet or exceed all ANIS/TIA/EIA performance requirements. Contractor will be required to submit all pre-project and post project documentation including test documentation and registration forms necessary to system coverage under this program.
- B. System coverage shall but is not limited to the following components:
 - 1. Cabling components
 - 2. Connecting Hardware
 - 3. Connectors
 - 4. Jacks/Outlets

PART 2 - PRODUCTS

2.1 PATHWAYS

- A. General Requirements: Comply with ANSI/TIA/EIA-569-A.
- B. Cable Support: NRTL labeled for support of Category 6A cabling, designed to prevent degradation of cable performance and pinch points that could damage cable.
 - 1. Support brackets with cable tie slots for fastening cable ties to brackets.
 - 2. Lacing bars, spools, J-hooks, and D-rings.
 - 3. Straps and other devices.
- C. Cable Trays:
 - 1. Manufacturers: Subject to compliance with requirements, provide products by one of the following available manufacturers offering products that may be incorporated into the Work including the following:
 - a. Cablofil Inc.
 - 2. Cable Tray Materials: Metal, suitable for indoors, and protected against corrosion by electroplated zinc galvanizing, complying with ASTM B 633, Type 1, not less than **0.000472 inch (0.012 mm)** thick, hot-dip galvanizing, complying with ASTM A 123/A 123M, Grade 0.55, not less than **0.002165 inch (0.055 mm)** thick.
 - a. Basket Cable Trays: **18 inches (455 mm) wide and 4 inches (100 mm)**. Wire mesh spacing shall not exceed 2 by 4 inches (50 by 100 mm). Basket cable trays are to be used in all common hallway areas as defined on drawings T11-62, T11-62, T11-71 & T11-72.

- b. Ladder Cable Trays: Nominally **18 inches (455 mm)** wide, and a rung spacing of **12 inches (305 mm)**. Ladder trays shall be used in all MDF / IDF closets as defined on drawing T14-01.

- D. Conduit and Boxes: Comply with requirements in Division 26 Section "Raceway and Boxes for Electrical Systems". **"Flexible metal conduit shall not be used"**.
 - 1. Outlet boxes shall be no smaller than 2 inches (50 mm) wide, 3 inches (75 mm) high, and 2-1/2 inches (64 mm) deep.

2.2 UTP CABLE

- A. Manufacturers: Subject to compliance with requirements, provide products by one of the following:
 - 1. Berk-Tek LANmark 10G2 #11085339, CAT6A (Color Blue for IS)
 - 2. Berk-Tek LANmark 10G2 #11085339, CAT6A (Color Blue for CE - Clinical Engineering)
- B. Description: 100-ohm, 4-pair UTP:
 - 1. Comply with ICEA S-90-661 for mechanical properties.
 - 2. Comply with ANSI/TIA/EIA-568-B.1 for performance specifications.
 - 3. Comply with ANSI/TIA/EIA-568-B.2, Category 6A.
 - 4. Listed and labeled by an NRTL acceptable to authorities having jurisdiction as complying with UL 444 and NFPA 70 for the following type (or equivalent).
 - 5. Type requirements in subparagraphs below are minimum requirements and may be revised to suit Project. Retain options if "permitted substitutions," as defined in NFPA 70, are appropriate for this Project.
 - 6. Communications Plenum Cable: Type CMP

2.3 UTP CABLE HARDWARE

- A. Manufacturers: For specific manufacturers and part numbers, see Section 270002, "Unit Pricing". Subject to compliance with requirements, provide products pricing of manufactures below for leveling:
 - 1. Patch Panels:
 - a. Ortronics 48-Port Patch Panel - 568A Pinning (OR-PHD6AU48)
- B. General Requirements for Cable Connecting Hardware: Comply with ANSI/TIA/EIA-568-B.2, IDC type, with modules designed for punch-down caps or tools. Cables shall be terminated with connecting hardware of same category or higher.
- C. Patch Panel: Modular panels housing multiple-numbered jack units with IDC-type connectors 568A pinning at each jack for permanent termination of pair groups of installed cables.
 - 1. Number of Jacks per Field: One for each four-pair UTP cable indicated.
- D. Jacks and Jack Assemblies: Modular, color-coded, eight-position modular receptacle units with integral IDC-type terminals.
- E. Patch Cords: Factory-made, four-pair cables. Exact length and quantity to be field coordinated with Client.
 - 1. Patch cords shall have bend-relief-compliant boots and color-coded icons to ensure Category 6A performance. Patch cords shall have latch guards to protect against snagging.
 - 2. Patch cords shall have color-coded boots for circuit identification.
 - 3. Patch cords shall be manufactured by the same company as the cable plant.

2.4 TELECOMMUNICATIONS OUTLET/CONNECTORS

- A. Manufacturers: Subject to compliance with requirements, provide products pricing of manufactures below:
 - 1. Work Area Outlets – Color to be coordinate on site with the architect
 - a. Ortronics TracJack 1-Gang 6 Port Faceplate (OR-40300545)
 - b. Ortronics TracJack Category 6A/10G Modular Outlet (OR-TJ6A)
 - c. TracJack F Connector 75 ohm Insert (OR-63700006)
 - d. Faceplate Blank Inserts 10 pack (OR-42100002)
 - e. Blue Data Icon (OR-40326200)
- B. Modular Outlets: 100-ohm, balanced, twisted-pair connector; four-pair, eight-position modular. Comply with ANSI/TIA/EIA-568-B.1.
- C. All modular outlets shall be color coded for identification purposes. Refer to drawing package for colors and outlet configuration and/other application requirement. Verify colors with owner before purchase;
- D. Work Area Outlets: connector assemblies mounted in single faceplate, as denoted on drawings.
 - 1. Plastic Faceplate: High-impact plastic. Coordinate color with Division 26 Section "Wiring Devices."
 - 2. For use with snap-in jacks accommodating any combination of UTP, optical fiber, and coaxial work area cords.
 - 3. Legend: Machine printed, in the field, using adhesive-tape label.
 - 4. Legend: Snap-in, clear-label covers and machine-printed paper inserts.

2.5 GROUNDING

- A. Comply with requirements in Division 26 Section "Grounding and Bonding for Electrical Systems" for grounding conductors and connectors.
- B. Comply with ANSI-J-STD-607-C.

2.6 IDENTIFICATION PRODUCTS

- A. Comply with ANSI/TIA/EIA-606-A and UL 969 for labeling materials, including label stocks, laminating adhesives, and inks used by label printers.
- B. Comply with requirements in Division 26 Section "Identification for Electrical Systems."

2.7 SOURCE QUALITY CONTROL

- A. Testing Agency: Engage a qualified testing agency to evaluate cables.
- B. Factory test UTP and optical fiber cables on reels according to ANSI/TIA/EIA-568-B.1.
- C. Factory test UTP cables according to ANSI/TIA/EIA-568-B.2.
- D. Cable will be considered defective if it does not pass tests and inspections.
- E. Prepare test and inspection reports.

PART 3 - EXECUTION

3.1 ENTRANCE FACILITIES

- A. Coordinate backbone cabling with the protectors and demarcation point provided by communications service provider.

3.2 WIRING METHODS

- A. Wiring Method: Install cables in raceways and cable trays except within consoles, cabinets, desks, and counters and except in accessible ceiling spaces, in attics, and in gypsum board partitions where unenclosed wiring method may be used. Conceal raceway and cables except in unfinished spaces.
 - 1. Install plenum cable in environmental air spaces, including plenum ceilings.
 - 2. Comply with requirements for raceways and boxes specified in Division 26 Section "Raceway and Boxes for Electrical Systems."
- B. Wiring Method: Conceal conductors and cables in accessible ceilings, walls, and floors where possible.
- C. Wiring within Enclosures: Bundle, lace, and train cables to terminal points with no excess and without exceeding manufacturer's limitations on bending radii. Provide and use lacing bars and distribution spools.

3.3 INSTALLATION OF PATHWAYS

- A. Cable Trays: Comply with NEMA VE 2 and ANSI/TIA/EIA-569-A-7.
- B. Comply with requirements for demarcation point, pathways, cabinets, and racks specified in Division 27 Section "Communications Equipment Room Fittings." Drawings indicate general arrangement of pathways and fittings.
- C. Comply with ANSI/TIA/EIA-569-A for pull-box sizing and length of conduit and number of bends between pull points.
- D. Comply with requirements in Division 26 Section "Raceway and Boxes for Electrical Systems" for installation of conduits and wireways.
- E. Install manufactured conduit sweeps and long-radius elbows whenever possible.
- F. Pathway Installation in Communications Equipment Rooms:
 - 1. Position conduit ends adjacent to a corner on backboard where a single piece of plywood is installed, or in the corner of room where multiple sheets of plywood are installed around perimeter walls of room.
 - 2. Install cable trays to route cables if conduits cannot be located in these positions.
 - 3. Secure conduits to backboard when entering room from overhead.
 - 4. Extend conduits 3 inches (76 mm)] above finished floor.
 - 5. Install metal conduits with grounding bushings and connect with grounding conductor to grounding system.
- G. Backboards: Install backboards with 96-inch (2440-mm) dimension vertical. Butt adjacent sheets tightly, and form smooth gap-free corners and joints.

3.4 INSTALLATION OF CABLES

- A. Comply with NECA 1.
- B. General Requirements for Cabling:
 - 1. Comply with ANSI/TIA/EIA-568-B.1.
 - 2. Comply with BICSI ITSIM, Ch. 6, "Cable Termination Practices."
 - 3. Install 110-style IDC termination hardware unless otherwise indicated.
 - 4. MUTOA shall not be used as a cross-connect point.
 - 5. Consolidation points may be used only for making a direct connection to telecommunications outlet/connectors:
 - a. Do not use consolidation point as a cross-connect point, as a patch connection, or for direct connection to workstation equipment.
 - b. Locate consolidation points for UTP at least 49 feet (15 m) from communications equipment room.
 - 6. Terminate conductors; no cable shall contain unterminated elements. Make terminations only at indicated outlets, terminals, cross-connects, and patch panels.
 - 7. Cables may not be spliced. Secure and support cables at intervals not exceeding 30 inches (760 mm) and not more than 6 inches (150 mm) from cabinets, boxes, fittings, outlets, racks, frames, and terminals.
 - 8. Install lacing bars to restrain cables, to prevent straining connections, and to prevent bending cables to smaller radii than minimums recommended by manufacturer.
 - 9. Bundle, lace, and train conductors to terminal points without exceeding manufacturer's limitations on bending radii, but not less than radii specified in BICSI ITSIM, "Cabling Termination Practices" Chapter. Install lacing bars and distribution spools.
 - 10. Do not install bruised, kinked, scored, deformed, or abraded cable. Do not splice cable between termination, tap, or junction points. Remove and discard cable if damaged during installation and replace it with new cable.
 - 11. Cold-Weather Installation: Bring cable to room temperature before unspooling. Heat lamps shall not be used for heating.
 - 12. In the communications equipment room, install a 10-foot (3-m-) long service loop on each end of cable.
 - 13. Pulling Cable: Comply with industry standards. Monitor cable pull tensions.
- C. UTP Cable Installation:
 - 1. Comply with ANSI/TIA/EIA-568-B.2.
 - 2. Do not untwist UTP cables more than 1/2 inch (12 mm) from the point of termination to maintain cable geometry.
- D. Open-Cable Installation:
 - 1. Install cabling with horizontal and vertical cable guides in telecommunications spaces with terminating hardware and interconnection equipment.
 - 2. Suspend UTP cable in a wireway or pathway a minimum of 8 inches (200 mm) above ceilings by cable supports not more than 60 inches (5') on centers.
 - 3. Cable shall not be run through structural members or in contact with pipes, ducts, or other potentially damaging items.
- E. Group connecting hardware for cables into separate logical fields.
- F. Separation from EMI Sources:

1. Comply with BICSI TDMM and TIA/EIA-569-A for separating unshielded copper voice and data communication cable from potential EMI sources, including electrical power lines and equipment.
2. Separation between open communications cables or cables in nonmetallic raceways and unshielded power conductors and electrical equipment shall be as follows:
 - a. Electrical Equipment Rating Less Than 2 kVA: A minimum of 5 inches (127 mm).
 - b. Electrical Equipment Rating between 2 and 5 kVA: A minimum of 12 inches (300 mm).
 - c. Electrical Equipment Rating More Than 5 kVA: A minimum of 24 inches (610 mm).
3. Separation between communications cables in grounded metallic raceways and unshielded power lines or electrical equipment shall be as follows:
 - a. Electrical Equipment Rating Less Than 2 kVA: A minimum of 2-1/2 inches (64 mm).
 - b. Electrical Equipment Rating between 2 and 5 kVA: A minimum of 6 inches (150 mm).
 - c. Electrical Equipment Rating More Than 5 kVA: A minimum of 12 inches (300 mm).
4. Separation between communications cables in grounded metallic raceways and power lines and electrical equipment located in grounded metallic conduits or enclosures shall be as follows:
 - a. Electrical Equipment Rating Less Than 2 kVA: No requirement.
 - b. Electrical Equipment Rating between 2 and 5 kVA: A minimum of 3 inches (76 mm).
 - c. Electrical Equipment Rating More Than 5 kVA: A minimum of 6 inches (150 mm).
5. Separation between Communications Cables and Electrical Motors and Transformers, 5 kVA or HP and Larger: A minimum of 48 inches (1200 mm).
6. Separation between Communications Cables and Fluorescent Fixtures: A minimum of 5 inches (127 mm).

3.5 FIRESTOPPING

- A. Comply with requirements in Division 07 Section "Penetration Fire-stopping."
- B. Comply with ANSI/TIA/EIA-569-A, Annex A, "Fire-stopping."
- C. Comply with BICSI TDMM, "Fire-stopping Systems" Article.

3.6 GROUNDING

- A. Install grounding according to Section 26, "Grounding, Bonding, and Electrical Protection".
- B. Comply with ANSI-J-STD-607-B.
- C. Locate grounding bus bar to minimize the length of bonding conductors. Fasten to wall allowing at least 2-inch (50-mm) clearance behind the grounding bus bar. Connect grounding bus bar with a minimum No. 4 AWG grounding electrode conductor from grounding bus bar to suitable electrical building ground.
- D. Bond metallic equipment to the grounding bus bar, using not smaller than No. 6 AWG equipment grounding conductor.

3.7 IDENTIFICATION

- A. Identify system components, wiring, and cabling complying with ANSI/TIA/EIA-606-A. Comply with requirements for identification specified in Division 26 Section "Identification for Electrical Systems."
 - 1. Administration Class: 3.
 - 2. Color-code cross-connect fields. Apply colors to voice and data service backboards, connections, covers, and labels.
- B. Using cable management system software specified in Part 2, develop Cabling Administration Drawings for system identification, testing, and management. Use unique, alphanumeric designation for each cable and label cable, jacks, connectors, and terminals to which it connects with same designation. At completion, cable and asset management software shall reflect as-built conditions.
- C. Comply with requirements in Division 09 Section "Interior Painting" for painting backboards. For fire-resistant plywood, do not paint over manufacturer's label.
- D. Paint and label colors for equipment identification shall comply with ANSI/TIA/EIA-606-A for Class 3 level of administration, including optional identification requirements of this standard.
- E. Cable Schedule: Post in prominent location in each equipment room and wiring closet. List incoming and outgoing cables and their designations, origins, and destinations. Protect with rigid frame and clear plastic cover. Furnish an electronic copy of final comprehensive schedules for Project.
- F. Cabling Administration Drawings: Show building floor plans with cabling administration-point labeling. Identify labeling convention and show labels for telecommunications closets, backbone pathways and cables, terminal hardware and positions, horizontal cables, work areas and workstation terminal positions, grounding buses and pathways, and equipment grounding conductors. Follow convention of ANSI/TIA/EIA-606-A. Furnish electronic record of all drawings, in software and format selected by Owner.
- G. Cable and Wire Identification:
 - 1. Label each cable within 4 inches (100 mm) of each termination and tap, where it is accessible in a cabinet or junction or outlet box, and elsewhere as indicated.
 - 2. Each wire connected to building-mounted devices is not required to be numbered at device if color of wire is consistent with associated wire connected and numbered within panel or cabinet.
 - 3. Exposed Cables and Cables in Cable Trays and Wire Troughs: Label each cable at intervals not exceeding 25 feet (4.5 m).
 - 4. Label each terminal strip and screw terminal in each cabinet, rack, or panel.
 - a. Individually number wiring conductors connected to terminal strips, and identify each cable or wiring group being extended from a panel or cabinet to a building-mounted device shall be identified with name and number of particular device as shown.
 - b. Label each unit and field within distribution racks and frames.
 - 5. Identification within Connector Fields in Equipment Rooms and Wiring Closets: Label each connector and each discrete unit of cable-terminating and connecting hardware. Where similar jacks and plugs are used for both voice and data communication cabling, use a different color for jacks and plugs of each service.

6. Uniquely identify and label work area cables extending from the MUTOA to the work area. These cables may not exceed the length stated on the MUTOA label.

H. Labels shall be preprinted or computer-printed type with printing area and font color that contrasts with cable jacket color but still complies with requirements in ANSI/TIA/EIA-606-A.

1. Cables use flexible vinyl or polyester that flex as cables are bent.

3.8 FIELD QUALITY CONTROL

A. Perform tests and inspections.

B. Tests and Inspections:

1. Visually inspect UTP and optical fiber cable jacket materials for NRTL certification markings. Inspect cabling terminations in communications equipment rooms for compliance with color-coding for pin assignments, and inspect cabling connections for compliance with ANIS/TIA/EIA-568-B.1.

2. Visually confirm Category 6A, marking of outlets, cover plates, outlet/connectors, and patch panels.

3. Visually inspect cable placement, cable termination, grounding and bonding, equipment and patch cords, and labeling of all components.

4. Test UTP backbone copper cabling for DC loop resistance, shorts, opens, intermittent faults, and polarity between conductors. Test operation of shorting bars in connection blocks. Test cables after termination but not cross-connection.

a. Test instruments shall meet or exceed applicable requirements in ANSI/TIA/EIA-568-B.2. Perform tests with a tester that complies with performance requirements in "Test Instruments (Normative)" Annex, complying with measurement accuracy specified in "Measurement Accuracy (Informative)" Annex. Use only test cords and adapters that are qualified by test equipment manufacturer for channel or link test configuration.

5. UTP Performance Tests:

a. Test for each telecommunications outlet/connector. Contractor shall test 100% of the horizontal cabling infrastructure in accordance with the requirements specified under ANSI/TIA/EIA-568-B.1 and TIA/EIA-568-B.2 as well as all the selected manufacturers certification and warranty program, including but not limited to the following tests:

1) Wire map.

2) Length (physical vs. electrical, and length requirements).

3) Insertion loss.

4) Near-end crosstalk (NEXT) loss.

5) Power sum near-end crosstalk (PSNEXT) loss.

6) Equal-level far-end crosstalk (ELFEXT).

7) Power sum equal-level far-end crosstalk (PSELFEXT).

8) Return loss.

9) Propagation delay.

10) Delay skew.

6. Final Verification Tests: Perform verification tests for UTP systems after the complete communications cabling and workstation outlet/connectors are installed.

- a. Voice Tests: These tests assume that dial tone service has been installed. Connect to the network interface device at the demarcation point. Go off-hook and listen and receive a dial tone. If a test number is available, make and receive a local, long distance, and digital subscription line telephone call.
 - b. Data Tests: These tests assume the Information Technology Staff has a network installed and is available to assist with testing. Connect to the network interface device at the demarcation point. Log onto the network to ensure proper connection to the network.
7. Optical Fiber Cable Tests:
- a. Test instruments shall meet or exceed applicable requirements in ANSI/TIA/EIA-568-B.1. Use only test cords and adapters that are qualified by test equipment manufacturer for channel or link test configuration.
 - b. Link End-to-End Attenuation Tests:
 - 1) Horizontal and multimode backbone link measurements: Test at 850 or 1300 nm in 1 direction according to ANSI/TIA/EIA-526-14-A, Method B, One Reference Jumper.
 - 2) Attenuation test results for backbone links shall be less than 2.0 dB. Attenuation test results shall be less than that calculated according to equation in ANSI/TIA/EIA-568-B.1.
- C. Document data for each measurement. Data for submittals shall be printed in a summary report that is formatted similar to Table 10.1 in BICSI TDMM, or transferred from the instrument to the computer, saved as text files, and printed and submitted.
- D. End-to-end cabling will be considered defective if it does not pass tests and inspections.
- E. Prepare test and inspection reports.
- 3.9 DEMONSTRATION
- A. Train Owner's maintenance personnel in cable-plant management operations, including changing signal pathways for different workstations, rerouting signals in failed cables, and keeping records of cabling assignments and revisions when extending wiring to establish new workstation outlets. Include training in cabling administration software if applicable and/or deemed necessary by the Owner or their agent.

END OF SECTION

This page is intentionally left blank.

SECTION 27 40 00
PUBLIC ADDRESS SYSTEM

PART 1 - GENERAL

1.1 RELATED SECTIONS

- A. 232123Section 01 81 13 "Sustainable Design Requirements – LEED v4 for Building Design & Construction – New Construction" for sustainable design requirements and detailed sustainable design submittal requirements.
- B. Section 01 74 19 "Construction and Demolition Waste Management and Disposal" for disposal of construction, demolition and packaging waste disposal requirements.

1.2 SUMMARY

- A. Sustainable Building Requirements:
 - 1. The Owner requires the Contractor to implement practices and procedures to meet the project's environmental performance goals, which include achieving LEED version 4 **Certified** level Certification. Specific project goals that may impact this area of work include: use of recycled-content materials; use of locally-manufactured materials; use of low-emitting materials; construction waste recycling; and the implementation of a construction indoor air quality management plan. The Contractor shall ensure that the requirements related to these goals, as defined in the Articles below, are implemented to the fullest extent. Substitutions, or other changes to the work proposed by the Contractor or their Subcontractors, shall not be allowed if such changes compromise the aforementioned environmental goals and LEED certification.

1.3 SCOPE OF WORK

- A. Drawings and general provisions of the Contract, including General and Supplementary Conditions and Division 01 Specification Sections, apply to this Section.

1.4 PUBLIC ADDRESS SYSTEM

- A. This section of the specification defines the functional details of the public address system to be furnished and installed in the MMC new space.

1.5 SYSTEM FUNCTIONAL REQUIREMENTS

- A. The system design consists of a two-zone paging system: Operating Rooms (ORs) are one zone and all other areas are the second zone. All source and amplification

equipment will be installed in a 2-post equipment rack in the Data Room. The equipment rack shall be furnished and installed by the IT contractor. A dedicated telephone number will be selected for paging purposes. The Phone system will require a security code to forward the call to the paging system controller. The Phone system is Owner Furnished. The system can be set to limit the duration of the message being transmitted. Refer to drawings for quantities and locations. The functional requirements are as follows:

1. Audio System:
 - a. Telephone interface module.
 - b. System central processing module.
 - c. Zone paging module.
 - d. 120V AC/12V DC power supply to provide low voltage power to the zone paging module.
 - e. Provide a rack mounting kit for the telephone interface module, central processing module and the zone paging modules.
 - f. Provide a paging mixer with microphone input modules, which will combine and route the two microphone audio inputs to the paging system telephone interface module.
 - g. Provide a rack mounting kit for the paging mixer.
 - h. Provide RJ11 modular jack boxes and six conductor modular cable jumpers to route the microphone audio from the paging mixer to the telephone interface module. Quantities as required.
 - i. 100 Watt paging amplifiers with rack mounting kits. These amplifiers will be rack mounted on plywood wallfield. Quantities as required.
 - j. 35 Watt capacity, speaker zone attenuators with two (2) gang, surface mountable junction box enclosures. The attenuator junction box enclosures need to be a minimum three inches in depth to adequately house the attenuator controls. These attenuators and enclosures will be mounted adjacent to the equipment rack.
 - k. 10 Watt capacity, speaker zone attenuator. These attenuators will be wall mounted in Conference Rooms.
 - l. Audio distribution amplifier. For installations requiring multiple paging amplifiers tied together from a common paging input to control impedance and stabilize output levels.
 - m. 8" Diameter, ceiling speaker assemblies. These assemblies consist of a speaker, transformer, enclosure, tile-bridge and grille baffle. Speaker assemblies will be recess mounted in hung ceiling areas. Refer to Communication drawings (T11-61, T11-62, T11-71 & T11-72) for exact speaker placement.
 - n. Provide all 2-conductor, 16 gauge, shielded plenum-rated cables, connectors, etc. required to complete a full working system.
2. Miscellaneous
 - a. 19" wide, 84" high 2-post equipment rack (by others).
 - b. Rack-mounted UPS dedicated for PA equipment.
 - c. Provide all cables, connectors, etc. required to complete a full working system.

1.6 SYSTEM INTERCONNECTIONS

- A. The functional interconnections of the public address system shall be as detailed on the specified drawings.

- B. The audio contractor shall provide all required interconnection cable, all connectors, plates, etc. to facilitate the installation of a fully functional public address system, as detailed within these specifications and drawings.

1.7 RELATED WORK SPECIFIED ELSEWHERE

- A. The following equipment and systems are NOT provided under the terms of this specification and/or contract:
 - 1. Power outlets.
 - 2. All wall junction boxes, conduit and pull boxes.

1.8 INSTRUCTIONS TO BIDDERS

A. QUALIFICATION OF BIDDERS

- 1. The Bidder shall be a firm with at least five (5) years' experience in the fabrication, assembly and installation of public address systems of similar complexity, magnitude and quality as specified for the subject project, and shall submit documentation to this effect along with submission of the bid return.

1.9 DEFINITION OF TERMS

- A. The term "Owner" shall refer to MMC.
- B. The Term "Architect" shall refer to Perkins+Will
- C. The term "Consultant" shall refer to AKF Group, LLC.
- D. The term "Bidder" shall refer to any firm submitting a bid in response to these issued specifications.
- E. The term "Contractor" shall refer to the Systems Contractor who has been awarded the contract for the subject project and who has responsibility for performance of the work specified herein.
- F. The term "NIC" shall refer to material(s) and work, which is Not in Contract (not included in this specification) and for which the Contractor is NOT responsible except as otherwise noted and/or detailed herein.
- G. The term "OFE" shall refer to Owner Furnished Equipment, which will be provided by the owner to the Contractor. The Contractor shall be responsible for collecting and/or removing such equipment from the owners premises (the equipment's present location) and installing or re-installing the equipment at the audiovisual system site in good functional order as detailed herein.
- H. The term "shall" is mandatory; the term "will" is informative; the term "should" is advisory; and the term "provide" means to furnish and install.

1.10 INFORMATION TO BE SUBMITTED WITH THE BID RETURN

A. Equipment Costs

- 1. The bid return (response) shall include a detailed listing of all equipment to be supplied. Each equipment component shall be individually priced. Equipment costs shall reflect all required and/or requested modifications and/or

accessories. Any and all substitutions for specified equipment shall be listed and individually priced on separate pages.

B. Non-Equipment Costs

1. Non-equipment costs shall be detailed for each of the following categories:
 - a. Engineering: Including all required designs, drawings, run-sheets, instruction manuals, etc.
 - b. Pre-installation/Installation: Including all on-site installation and wiring. Coordination and supervision, testing, system check-outs, Owner training, etc. to be performed on or off the Owner's premises.
 - c. General and Administrative: To include all G & A expenses, shipping, insurance and guarantees.

C. Warranty Statement

1. In order to maintain certain manufacturer's warranties, system equipment must be installed, aligned and serviced by those installers recognized and authorized by said manufacturers to be capable of performing such duties. If a certain installer is NOT so authorized by a particular manufacturer, it is solely their responsibility to make such arrangements to come into such compliance and they shall bear all costs and consequences thereof.
2. The bidder shall include a statement of warranty on the entire system to be installed and on the individual equipment components of the system. The system warranty shall be for a minimum of 365 days from the date of system acceptance by the Consultant and/or the Owner's representative. This warranty shall obligate the Contractor to provide all equipment, materials, and labor for repair, at no charge to the Owner during the warranty period, in the event of system or equipment malfunction
3. All manufacturers' equipment warranties shall be activated in the Owner's name and shall commence on the date of system acceptance. In the case of Contractor-modified equipment, the manufacturer's warranty is normally voided. In such cases, the Contractor shall provide the Owner with a warranty equivalent to that of the original manufacturer.

D. Service Contract

1. The Bidder shall offer a separate annual service contract, covering all installed systems. This service contract shall cover a minimum of three (3) visits per year, at regular intervals, in order to perform operational checks of the system and equipment as recommended by respective manufacturers. The service contract shall commence immediately after expiration of the warranty period. A "per-component" price for the service contract shall be submitted with the bid.
2. The Bidder shall also submit separate pricing for other, non-routine, emergency, "on-call" service visits and an "in-shop" hourly rate for repair and maintenance work.
3. Service and service contract related costs shall NOT be commingled with the costs for the system's base-bid.

E. Schedule of Implementation

1. The bidder shall submit a scheduling plan with the bid return, indicating the various pertinent "terminal" dates after the contract award for completion of design, pre-installation work completion, on-site installation, and testing/acceptance.

F. Alternate Equipment

1. All bids shall be submitted on the basis of the recommended equipment listed in the part 2, products section of the specification.
2. The Bidder may propose alternate equipment. However, all such proposals shall be submitted separately and will be identified as "alternate(s)" with equipment costs shown as separate and apart from the costs of the equipment "as specified."
3. Proposals for alternate equipment will receive careful and equitable consideration if differences do not result in a departure from the overall intent of the system design and operation, and are demonstrated to be in the best interests of the Owner.
4. All such proposals for alternate equipment shall be accompanied by complete technical information and specifications, and "cut-sheets" for the equipment so proposed. The Bidder shall identify any and all substantive differences between the "alternate" and "specified" equipment.

G. Exceptions and Proposed Modifications

1. Should the Bidder wish to propose recommendations which will enhance the performance of the system, or reduce costs without loss of performance, such comments shall be made in the bid submissions. All suggestions which are of value to the Owner, shall be taken into consideration in the evaluation of bid returns. All such proposals shall be made as "alternative(s)", with the appropriate cost modifications clearly shown separate and apart from the costs of the system "as specified."
2. Any and all exceptions to specifications and related drawings must be made with the bid submission. In the absence of exceptions, these specifications and related drawings shall be binding in letter and intent upon the successful Bidder. It will be further assumed that the Bidder has examined all designs and specifications in detail and is prepared to accept full responsibility for the performance of the complete system installation as designed and specified

H. Sub-Contract Information

1. If the Bidder proposes to sub-contract any portion of the system installation work, as provided for under Section 1.7 which follows, any such sub-contractors shall be clearly identified and their responsibilities and qualifications detailed in the Bidder's bid submission. Any and all work performed by a sub-contractor shall be considered fully as part of the primary Bidder's contract and responsibility.

I. Visit to Site

1. All Bidders may request to make a "Pre-Bidder's" site inspection before submission of bids. The date of the site visit shall be included in the bid return. The Bidder shall arrange for the site-visit with the Owner's representatives.

1.11 SPECIFICATION DRAWINGS

- A. All drawings referred to herein are furnished with and become an integral part of this specification. These drawings and specifications shall remain the property of the Owner and shall be returned to the Owner by all unsuccessful Bidders, within ten (10) days after formal notification of contract award.

1.12 SPECIFICATION INFORMATION REQUESTS

- A. Any requests for clarification, substitution, or changes to these specifications and/or drawings shall be directed to the engineer. These information requests will be entertained no later than two days before the bid closing date.

1.13 SUB-CONTRACT

- A. If the Bidder proposes to sub-contract the installation and/or wiring, or any portion of this work, the Bidder shall provide direct supervision of any and all sub-contracted work.
- B. As a result of the complexity and criticality of the specified public address system, the supervision of sub-contracted work shall not be intermittent, but MUST be continuous for the entire duration of such installation.
- C. If it is the intent of the Bidder to "team" with one or more additional contractors, then this must be clearly stated and so identified the Bidder's bid return. The Contractor (Bidder) who is returning the bid shall be considered as the "prime" with respect to these circumstances, and will assume and accept full responsibility for the performance of all members of the "team," including themselves and all other sub-contractors and/or sub/sub-contractors engaged in the performance of the contract.

1.14 INVESTIGATION OF CONTRACTUAL AND/OR SCHEDULING QUESTIONS

- A. It shall be the sole responsibility of the Bidder to investigate any and all potential contract, union-related and scheduling questions and issues, and to guarantee compliance with all requirements and regulations, which shall be in effect on the job site. Any potential problems in this regard should be clearly identified and addressed in the bid return.

1.15 AWARD OF CONTRACT

- A. A single award of contract will be made for all systems as detailed in this specification. Quoted prices shall remain firm for a period of sixty (60) days.
- B. The Owner reserves the right to reject any or all bids for any reason.

PART 2 - PRODUCTS

2.1 Paging System Telephone Interface Module, Rack Mounted.

- A. Manufacturer: Bogen
 - 1. Model number: PCMTIM
 - 2. Include pricing for one (1) spare unit.

2.2 Paging System Central Processing Module, Rack Mounted.

- A. Manufacturer: Bogen
 - 1. Model number: PCMCPU
 - 2. Include pricing for one (1) spare unit.

2.3 Paging System Zone Paging Module, Rack Mounted.

- A. Manufacturer: Bogen
 - 1. Model number: PCMZPM
 - 2. Include pricing for one (1) spare unit.

2.4 Paging System Power Supply.

- A. Manufacturer: Bogen
 - 1. Model number: PCMPS2
 - 2. Include pricing for one (1) spare unit.

2.5 Rack Mount Kit for TIM, CPU and ZPM's

- A. Manufacturer: Bogen
 - 1. Model number: RPK88

2.6 Paging Mixer, Rack Mounted.

- A. Manufacturer: Bogen
 - 1. Model number: VMIX
 - 2. Include pricing for one (1) spare unit.

2.7 Microphone Input Module for Paging Mixer

- A. Manufacturer: Bogen
 - 1. Model number: MIC2S
 - 2. Include pricing for one (1) spare unit.

2.8 Rack Mounting Kit for Paging Mixer

- A. Manufacturer: Bogen
 - 1. Model number: RPK87
 - 2. Include pricing for one (1) spare unit.

2.9 Microphone with Push-to-Talk Switch

- A. Manufacturer: Bogen
 - 1. Model number: DDU-250
 - 2. Include pricing for one (1) spare unit.

2.10 Paging Amplifier

- A. Manufacturer: Bogen Paging Amplifier, Rack Mounted
 - 1. Part number: Biamp. AudiaFlex
 - 2. Include pricing for one (1) spare unit.
- B. Manufacturer: Bogen Paging Amplifier, 100 Watt, Wall Mounted
 - 1. Part number: TPU100B
 - 2. Include pricing for one (1) spare unit.

- 2.11 Rack Mounting Kit for Paging Amplifier
- A. Manufacturer: Bogen
 - 1. Part number: RPK82
- 2.12 Speaker Zone Attenuator, 35 Watt Capacity, Wall Mounted
- A. Manufacturer: Bogen
 - 1. Model number: AT35A
- 2.13 Speaker Zone Attenuator, 10 Watt Capacity, Wall Mounted
- A. Manufacturer: Bogen
 - 1. Model number: AT10A
- 2.14 8" Diameter, Drop-In Ceiling Speaker Assembly with Speaker, Transformer, Enclosure, Tile Bridge and Grille (Off White) Use in Drop ceilings only.
- A. Manufacturer: Bogen
 - 1. Model number: CSD1X2VR
- 2.15 8" Diameter, Ceiling Speaker Assembly with Speaker, transformer, Enclosure, Tile Bridge and Grille (Off White). Use in Solid Sheetrock, Wood or Metal ceilings only.
- A. Manufacturer: Bogen
 - 1. Model number: S810T725PG8UVR
- 2.16 Reentrant Horn Loudspeakers. Use in all mechanical spaces and outdoor locations only.
- A. Manufacturer: Bogen
 - 1. Model number: SPT15A
- 2.17 8-Channel Audio Distribution Amplifier
- A. Manufacturer: Radio Design Labs
 - 1. Model number: RU-ADA4D
 - 2. Include pricing for one (1) spare unit.
- 2.18 UPS, Rack Mounted, 1500VA w/ NEMA 5-15P input
- A. Manufacturer: APC
 - 1. Part number: SMT1500RM2U
- 2.19 Miscellaneous Hardware, Cable, Connectors, RJ11 Module Boxes, Six Conductor Module Cable Jumpers, etc.
- A. Manufacturer: PA Contractor
 - 1. Part number: Custom

- 2.20 Speaker Cable Loop Terminal Block. Quantity as required.
- A. Manufacturer: GE
 - 1. Part number: CR151B26AF
- 2.21 2-Conductor, Plenum-Rated Audio Cable. 16-Gauge, Shielded.
- A. Manufacturer: West Penn
 - 1. Part number: 25294B or approved equal

PART 3 - EXECUTION

3.1 CONTRACTOR'S GENERAL RESPONSIBILITIES

- A. The Contractor shall be responsible for delivering a turnkey paging system to the Owner.
- B. The Contractor shall furnish all equipment and materials, whether specifically mentioned within this document or not, to insure provision of a complete and fully functional system in line with the requirements of this specification. NIC and OFE equipment and materials are exempted from this requirement.
- C. The Contractor shall generate all shop drawings and necessary information required for the complete installation of the audio system. The Contractor shall also provide (or sub-contract for) on-site installation and wiring, and shall provide on-going and thorough supervision and coordination of all work performed during the implementation phase.
- D. The Contractor shall be responsible for initial adjustment of the public address system as described within this document and shall provide all test and operational equipment required for the system check-out and acceptance testing. The Contractor shall provide hands-on, on-site training in the operations and maintenance of the audio system for those personnel as designated by the Owner.

3.2 NOT IN CONTRACT (NIC)

- A. Certain equipment and/or materials will be provided and installed by others. Unless otherwise indicated in these specifications, or on the related drawings, this equipment and material shall include the following:
 - 1. All conduit(s), wireways, connection boxes, pull-boxes, junction boxes and outlet boxes permanently installed in walls, floors and ceilings.
 - 2. All room lighting fixtures, dimmers, power receptacles, outlets, and interconnect wiring for these circuits.
 - 3. All electrical breaker panels required to power the paging system equipment.
 - 4. All structural work, wall openings, platforms, railings, stairs, fire prevention and safety devices, rough and finished trim, painting and patching, drapes, carpets, floor coverings, computer floors, glazing,
 - 5. Acoustical treatments and heating, ventilation, and air conditioning systems.
 - 6. Moveable furniture, desks, and chairs.

3.3 QUALITY OF MATERIALS AND EQUIPMENT

- A. All equipment and materials provided by the contractor shall be new and shall meet or exceed the latest published manufacturer's specifications in all respects.
- B. The Contractor shall supply the latest model of each piece of specified equipment available at the time of bidding.

3.4 CONTRACTOR'S DOCUMENTATION

- A. Prior to system fabrication, the Contractor shall submit (to the Consultant), for approval, any and all custom designs pertaining to the audio system. Drawing submittals shall be reproducible media preferably in machine-readable form. These designs include, but are not limited to, the following:
 - 1. Full system construction designs and point-to-point wiring schematic drawings, including all component values, and clearly showing complete letter and number identifications for all wires and cables as well as all jacks, terminals and connectors.
 - 2. All panels, plates and designation strips, including all details relevant to terminology, engraving, finish and color.
 - 3. Any and all custom designed support bases and shelves.
 - 4. Schematic drawings of all custom components, assemblies and circuitry.
 - 5. Any and all unusual equipment modifications.
 - 6. Run-sheets or field wiring details.
 - 7. All equipment components, whether stock manufacture or custom built, shall be supported by complete and detailed schematic drawings and replacement parts. NO "black boxes" or otherwise unidentified or unidentifiable components shall be acceptable under the terms of this specification.
- B. At completion of the full system installation, the Contractor shall provide two (2) copies each of the following:
 - 1. Equipment manufacturer's operation manuals for each piece of installed Audio equipment.
 - 2. "As Built" drawings for every item indicated in Section 3.4-1.
 - 3. System functional block drawing identical to the AKF specification drawing with addition of all input and output circuit cable and terminal block numbers as well as all jack field circuit I.D. designations. A copy of this drawing shall be framed in protective plastic and mounted near the audio system equipment rack.
 - 4. One System Operations and Maintenance Manual. This manual shall be produced by the Contractor specifically for the systems installed and outlined in this specification.
 - a. The "Operations" section shall describe all standard and typical procedures required to activate the system and each of its parts to provide for full system functionality as outlined in the General section of the specification.
 - b. Readers of these manuals shall be assumed to be technically competent, but unfamiliar with the particular facility and installation. It is expected that this manual will require a minimum of five (5) pages.
 - c. The "Maintenance" section shall provide a recommended maintenance schedule with reference to applicable pages in the manufacturer's maintenance manuals. When adequate information is not provided by

the manufacturer, the Contractor shall directly provide the information necessary for proper maintenance.

- d. NOTE: One copy of all above documentation will be retained by the Owner. One additional copy shall be delivered to the Consultant prior to System Acceptance Testing.
- e. This information MUST also be provided on CD in an easily readable format (e.g. Microsoft Word, Excel, and Adobe Acrobat). The CD shall be accessible to all computers running the Windows operating system.

3.5 SUB CONTRACT

- A. No sub-contracting will be allowed in the case of the Contractor's responsibilities (as defined within these specifications), unless specifically identified in the original bid submission and approved by the Consultant and Owner.
- B. The Contractor shall have sole responsibility for the satisfactory implementation and delivery of the audio system, even though the Contractor may have sub-contracted some portion of the installation or had specific manufactures install their own equipment.

3.6 COOPERATION WITH OTHER TRADES

- A. It shall be the Contractor's responsibility to cooperate, at all times and to the fullest extent, with any and all other trades performing work on premises in order to avoid lost-time, work stoppages, interference and other inefficiencies.

3.7 EQUIPMENT DELIVERY AND STORAGE

- A. Any and all equipment delivered or received prior to system installation shall be stored by the Contractor at their place of business. Any costs of shipping, or of any unusual storage requirements shall be borne by the Contractor. The Contractor shall inform the Owner no later than seven (7) days in advance of delivery to the installation site. It shall be the responsibility of the Contractor to make all appropriate arrangements with authorized personnel at the work site for the proper acceptance, handling, protection and storage of equipment so delivered.

3.8 CLEANUP AND REPAIR

- A. Upon completion of all work, the Contractor shall remove any and all refuse and rubbish from and about the Owner premises, and shall leave all areas and equipment clean and in a fully operational state.
- B. The Contractor shall be responsible for the repair of any damage caused to the premises by installation activities, at no cost or hardship to the Owner.

3.9 OWNER TRAINING

- A. The Contractor shall provide relevant on-the-job training (by a suitably qualified instructor) for those personnel designated by the Owner, in order to instruct them in the operation of the installed audio system. In the event that the Contractor does not have suitably qualified instructors on staff for specific highly sophisticated equipment components and/or systems, a manufacturer's representative for such

equipment will be provided by the Contractor at no additional cost to the Owner. All such training shall take place after the system is fully operational, but prior to acceptance testing. There shall be a minimum of 3 hours of training provided for systems covered under this specification.

3.10 PUBLICATION

- A. No information relative to the job covered under this specification may be released for publication without prior written consent and approval from the Owner and the Consultant.

3.11 INSURANCE

- A. Prior to commencing work, the Contractor shall procure and maintain, for the full duration of the system installation, such comprehensive liability and property damage insurance as shall protect both themselves and the Owner from claims for bodily injury, including accidental death, and for any claims of property damage which may arise from the operations under this contract and specification.

3.12 INSTALLATION PRACTICES

A. General

1. Installation shall be understood to include the delivery, unloading, positioning in place, securing to walls, floors, ceilings, counters or other structures as required, interconnect wiring of all system components, equipment alignment/adjustment and all other work whether or not expressly called for in this document which is necessary to result in complete and fully operational system.
2. All installation practices shall be in full accordance with, but not limited to, these specifications and drawings. Installation shall be performed in accordance with all applicable standards, requirements and recommendations of National, State and Local authorities having jurisdiction over these and other relevant matters.
3. If in the opinion of the Contractor, an installation practice is desired or required which runs contrary to these specifications and drawings, written request for modification shall be made to the Consultant. Any and all such modifications shall not take place without written approval.
4. During the system installation, and up to the date of final acceptance, the Contractor shall be under obligation to protect his finished and unfinished work against loss and/or damage. In the event of loss or damage, he shall replace or repair any and all work at no cost to the Owner.

B. Physical Installation

1. All equipment shall be firmly secured in place unless requirements of portability dictate otherwise.
2. All fastenings and supports shall be adequate to support their loads with a safety factor of at least three (3). All boxes, equipment, racks, stands, etc., shall be secured, plumb and square.
3. In the installation of equipment and cabling, full consideration shall be given not only to operational efficiency, but also to overall aesthetic factors.

C. Cable Installation

1. All wire bundles are to be neat and combed free of cable crossover. Using J-hook to support cable bundles at every 5 feet interval.
 2. All cables, regardless of length, shall be clearly marked with a permanent, wrap-around number or letter cable marker at both ends. There shall be no unmarked cables at any place or position in the paging system. Marking codes used on cables shall correspond to codes shown on drawings and/or run-sheets.
 3. No splices shall be permitted in any pull-boxes without prior permission from the Consultant.
 4. No cable shall be installed with a bend radius less than that recommended by the cable manufacturer.
- D. Connection Plate Receptacles
1. Audio (microphone or line level) - XLR type.
- E. Grounding Procedures
1. In order to eliminate or minimize potential problems resulting from improper grounding, and to achieve absolute minimum signal-to-noise ratios, the following grounding procedures shall be observed:
 - a. System Grounds
 - 1) A single, primary "system ground" shall be established for the system. All individual grounding conductors shall connect to this "system ground". The system ground shall be provided in the audio equipment area and shall consist of a copper bar of sufficient size to accommodate all secondary ground conductors.
 - 2) A copper conductor having a maximum of 0.1 Ohms total resistance shall connect the primary system ground to the nearest metallic electrical conduit of at least 2" in diameter. The paging Contractor shall be responsible for determining whether or not the metallic conduit is properly electrically bonded to the building ground system.
 - 3) If a secondary system grounding conductors is provided, this grounding conductor shall have a maximum of 0.1 Ohms of total resistance.
 2. Under no condition shall the AC neutral conductor, in either the power panel or in any receptacle outlet, be used as a system ground.
 - a. Audio Cable Shields:
 - 1) All audio cable shields shall be grounded at one (1) point only. NO exceptions shall be made. For ungrounded portable equipment, such as microphones, the shield should be connected at both ends but grounded at a single end only.
 - b. General:
 - 1) Because of the great number of variations in grounding systems, it shall be the responsibility of the Contractor to follow good engineering practice (as outlined above) and to deviate from these practices ONLY when deemed necessary to minimize "crosstalk" and to maximize signal-to-noise ratios in the audio system.
- 3.13 PERFORMANCE STANDARDS
- A. Unless restricted or prohibited under the terms of the published specifications of a particular equipment manufacturer, or, unless otherwise required under the terms

of this Detailed Specification, the following performance standards shall be met in each case and for all systems:

1. AUDIO:
 - a. S/N (including crosstalk and hum) 65dB minimum.
 - b. Total Harmonic Distortion ... 1% maximum from 30 Hz to 15,000 Hz.
 - c. Frequency Response ... within plus or minus 1.0 dB, 30Hz to 15,000 Hz.

B. PERFORMANCE TEST SIGNAL PATHS:

1. The signal paths for the above defined Performance Standards shall be as follows:
2. Audio:
 - a. From all source inputs (for microphones, etc.) through all audio equipment, etc., to all signal destinations.
 - b. Delineation of the above defined signal paths shall NOT exempt the Contractor from the responsibility of checking all paths and outlets for appropriate compliance with the Performance Standards.
 - c. During ALL Performance Testing, all equipment shall be operated under standard conditions as recommended by the manufacturer.

3.14 CONTRACTOR SYSTEM CHECK-OUT

- A. Before Acceptance Tests are scheduled, the Contractor shall perform his own system check-out. He shall furnish all required test equipment and shall perform all work that is necessary to determine and/or modify/correct performance of the system in order to meet the requirements of this Specification.

3.15 SYSTEM ACCEPTANCE TESTS

- A. System Acceptance Testing shall not be performed until the Contractor's own System Checkout has been completed and test results have been recorded and reviewed. The System Acceptance Tests will be supervised by the Consultant representative and will consist of the following:
 1. A physical inventory will be taken of all equipment on site and will be compared to equipment lists in the contract documents.
 2. The operation of all system equipment shall be demonstrated by the Contractor.
 3. Both subjective and objective tests will be required by the Consultant to determine compliance with the specifications. The Contractor shall be responsible for providing test equipment for these tests.
 4. All final, "as-built" drawings, run sheets, manuals, and other required documents, as detailed in Section 3.4, shall be on hand. Two complete sets of these documents shall be delivered to the Owner at this time. (One complete set shall have been delivered to the Consultant prior to scheduling of Acceptance Tests).
 5. In the event further adjustment is required, or that defective equipment is discovered which must be repaired or replaced, further testing may be either suspended or continued at the option of the Consultant.

6. Any charges for additional Consultant time required to oversee system tests due to improper system installation or previously failed system tests shall be the responsibility of, and charged directly to the Contractor.

END OF SECTION

Maine Medical Center
Portland, Maine
Construction Documents - East Tower 6 & 7 Addition

PERKINS+WILL
Project Number: 152181.000
26 January 2018
Addendum 1, 22 March 2018

This page is intentionally left blank.

SECTION 27 52 23

NURSE CALL SYSTEM

PART 1 - GENERAL

1.1 WORK INCLUDED

- A. Provide a complete working Nurse/Patient Communications Network based upon the specification outlined here to include all necessary devices that provide the functions listed in this specification for Maine Medical Center. This facility will be referenced as the OWNER in this specification.
- B. Refer to Section "Communications, General" for additional requirements.
- C. 232123Section 01 81 13 "Sustainable Design Requirements – LEED v4 for Building Design & Construction – New Construction" for sustainable design requirements and detailed sustainable design submittal requirements.
- D. Section 01 74 19 "Construction and Demolition Waste Management and Disposal" for disposal of construction, demolition and packaging waste disposal requirements.

1.2 SCOPE

- A. Maine Medical Center Campus Facility is replacing the current old system nurse call with a new Nurse Call network. The following is a schedule replacement that will occur during Construction.
- B. The Network will be expanded in the future to the remaining units.
- C. Sustainable Building Requirements:
 - 1. The Owner requires the Contractor to implement practices and procedures to meet the project's environmental performance goals, which include achieving LEED version 4 **Certified** level Certification. Specific project goals that may impact this area of work include: use of recycled-content materials; use of locally-manufactured materials; use of low-emitting materials; construction waste recycling; and the implementation of a construction indoor air quality management plan. The Contractor shall ensure that the requirements related to these goals, as defined in the Articles below, are implemented to the fullest extent. Substitutions, or other changes to the work proposed by the Contractor or their Subcontractors, shall not be allowed if such changes compromise the aforementioned environmental goals and LEED certification.

1.3 SUBMITTALS

- A. Provide submittals for the entire system including:
 - 1. Name of supplying contractor and project name.
 - 2. Complete equipment list consisting of: Component quantities, equipment manufacturer, model number, and description of each component being supplied.

3. One catalog sheet per product of equipment listed in Part 2 of submittal; in the exact order as listed in Part 2 of the submittal.
4. Riser Wiring Diagram showing all devices. These drawings will show all wiring types by wire gauge, conductors and wire manufacturer. These drawings must be updated prior to completion of any work to reflect changes that may have been made during actual installation.
5. Typical terminal Wiring diagram for each type of device.
6. Terminal Wiring Diagram for the Central Equipment Panel and Nurses' Master Station.

1.4 GENERAL REQUIREMENTS

- A. Make available to the Owner, within a 75 mile radius and 24 hour period, a local service department of an authorized manufacturer's distributor which shall stock the manufacturer's standard parts.
- B. Provide On-the-premises service furnished during normal work hours at no cost for a period of twelve months from the date of acceptance of the system.
- C. [On-the-premises service furnished at other than normal working hours shall be available and may be charged by the manufacturer's representative at current labor rates, based on the difference between normal working hour rate and the associated "off-normal" working hour rate.]
- D. All Nurse Communications Network devices shall be UL-1069 listed. This includes routers, hubs, switches, and room control devices. The nurse call network shall be an FDA Registered Class II (or higher) medical device and the system's manufacturer shall be an FDA Registered Operator.
- E. The system shall be capable of interconnecting with the hospital's LAN (Local Area Network). This connection shall be minimal and utilize only one Ethernet 100 Mbps (or optionally 1 GB) connection to accomplish all ADT, hospital information, reporting software and information exchange. The HL7 standard shall be utilized for receipt of patient information from the ADT system if required.
- F. Field wiring shall be CAT 5E or CAT 6 cable, control wiring for power distributions and very long runs, and utilize an optional fiber backbone (when distances exceed (295 feet) normal Ethernet limitations). Wiring shall be capable of either being installed in conduit or cable trays, where shown on the plans. Nurse Communications cabling may be run along with other low voltage and data cables where permitted by code. Nurse Communications cabling to be separated out from any high voltage AC or DC wiring that exceeds 90 volts, or which violates any national or local electrical code.
- G. The OWNER will provide one VPN connection. One VPN is for the servicing contractor to diagnose any maintenance issues and to maintain the system offsite. Diagnostic software shall be web based and permit e-mail notification of high level alarms. All software applications shall be HIPAA and PIPEDA compliant and shall allow for patient name aliases and alternative display methods. Complex user names, expiring passwords, granular permission settings and role based security shall be standard. All databases shall be ODBC compliant, MS SQL 2008 or later.
- H. Overall Nurse Communications Network shall utilize VoIP communications between all major components: nurse consoles, staff terminals, telephones and controllers. Any nurse call console and staff terminal must be able to answer any patient call placed in the network. Systems not utilizing the VoIP standard will not be

acceptable. The communication standard shall be SIP protocol when telephones are integrated. The OWNER will not be providing any analog ports to the nurse call network. As part of this contract, the OWNER will either supply or establish that there is a telephony call network which supports the SIP protocol within the OWNER'S facility. Systems requiring digital to analog converters will not be accepted.

- I. The capability to assign patients to staff shall be via a networked software infrastructure on existing OWNER workstations. There are no known software limits to the number of users or units being assigned. It shall also be possible to have multiple users logging onto system via barcode or other standard human interface devices. Log on process identifies user and the current device used that day.
- J. Ethernet ports will be provided by the OWNER for HL7 integration to the entire network. Those nurse call systems requiring more than one interface to the live environment will not be acceptable. Additional servers will be provided by the OWNER on an as needed basis for those specific nurse call options that are selected. All servers will be installed in the facilities data center. All software must be capable of being diagnosed and supported by the distributor remotely.
- K. The Network shall be expandable to any combination of over 15,000 bed, duty, or staff stations and 120,000 sub-stations connected as a contiguous interconnected system. Multiple buildings and intra-building connections may be linked together utilizing a fiber or an Ethernet connection. Audio communications between devices shall be digital and virtually non-blocking, so as to provide fast, instantaneous communications without queuing or delay.
- L. The Network shall be capable of backward compatibility to prior generation of Nurse/Patient Communications system manufactured by same vendor via a network adapter module. This module will allow calls from the prior generation system to appear and go into audio communication from the common consoles, staff terminals, duty stations, zone lights and PC displays as well as allow patient to staff assignment via a common client application.

1.5 DESCRIPTION OF SYSTEM

- A. System hardware shall consist of a nurse call network comprised of nurse consoles, PC consoles (OWNER provided), nurse call network controllers, patient stations, power supplies, battery back-up, dome lights, entertainment cords, call cords, pull cord stations, emergency push button stations, wiring and other options such as bed side-rail interfaces, wireless bed interface, computer interfaces, wireless/telephone network interfaces, staff terminals, RTLS (real time locating system) and network adapter module as shown on drawings. All necessary equipment required to meet the intent of these specifications, whether or not enumerated within these specifications, shall be supplied and installed to provide a complete and operating nurse/patient communications network.
- B. System hardware and firmware shall be the product of a single, reputable manufacturer with a proven history of product reliability and sole control over all source code. Manufacturer shall provide, free of charge, product firmware/software upgrades for a period of one year from date of installation for any product feature enhancements. Manufacturer shall provide a 5 year warranty on all manufactured hardware.

- C. All programming and firmware changes shall be accomplished on a working system without interruption to the normal operation of the system. Therefore, all system switches and controllers, which hold this firmware and system parameters must have DUAL storage. While updates are being made to one set of firmware, the system shall be working and fully functional on the original firmware (i.e. A and B memory blocks). It shall be possible to switch to the NEW system control software modules by a single system command. In the event of an error or failure in the update process, the system shall revert back to the previous firmware.
- D. All communications shall be full duplex audio, not only on handsets, but all loud speaking devices, including patient, staff, duty, and pillow speakers.
- E. Entire Network shall be supervised, including all sub-stations. Reporting of station failure shall be to any designated console, PC, e-mail, or wireless device. Remote diagnostics shall be utilized to quickly locate the source of the problem.
- F. Up to 99 different staff levels may be defined within the nurse call network to facilitate work flow within and outside of normal nurse call activity (i.e. environmental services, facilities, transportation, lab, pharmacy, etc.).
- G. Nurse call network shall support a VLAN configuration to separate activity in the nurse call network from other hospital LAN traffic. Nurse call network can span multiple subnets on a hospital's LAN.
- H. The nurse call network shall support at least 990 call processes to facilitate work flow and call escalations to various staff and or groups.
- I. Nurse call network shall support any Real Time Locating System (RTLS) via an open architectural interface.
- J. Nurse call network shall support any telephone device via an open architectural interface.
- K. Nurse call network shall support any ADT system via an open architectural interface.
- L. Nurse call network shall support any staff assignment system via an open architectural interface.
- M. Nurse call network shall support any data backup system.
- N. Nurse call network shall support HL7 integration with 3rd party systems for patient status and workflow including:
 - 1. Electronic Medical Records (EMR) with bi-directional room status and workflow
 - 2. Other systems providing HL7 status and event messages

1.6 WARRANTY

- A. The supplying contractor shall provide a warranty on the system which shall include all necessary labor and equipment to maintain the system(s) in full operation for a period of one year from the date of acceptance.
- B. Manufacturer shall provide, free of charge, product firmware/software upgrades throughout the 1 year warranty period for any product feature fixes.
- C. In addition, the equipment (parts) warranty for all core system components including control / switching equipment, power supplies, patient stations, sub-stations, and nurse consoles shall extend to a total of at least five (5) years.

Warranty for ancillary devices such as pillow speakers and call cords shall extend to a total of at least two (2) years.

- D. After the acceptance of the system(s) service shall be provided on the following basis:

Emergency Service -	Provided <u>24 hours a day</u> . When a total or catastrophic failure of equipment is reported to contractor, within 2 hours of notification , a service person will be on site. (An example of a catastrophic failure would be a hub failure or a nurse console failure.)
Routine Service -	Provided <u>within 4 business hours</u> (9 a.m. to 5 p.m., Monday through Friday, excluding holidays) of notification . When a minor failure of equipment is reported to contractor, a service person will be on site within 24 hours of notification. (An example of a minor failure includes peripheral equipment such as control stations, entertainment speakers, corridor lights, pull-cord stations, etc. which normally affect only one patient or patient room.)

PART 2 - PRODUCTS- HARDWARE

2.1 MANUFACTURERS

- A. The products specified shall be new and of the standard manufacture of a single reputable manufacturer. As a reference of standard and quality, functionality and operation, it is the request of the OWNER that bids be based only on equipment manufactured by Rauland-Borg Corporation distributed locally by SIGNET Systems.
1. Project Contact:
- B. The intent is to establish a standard of quality, function and features. It is the responsibility of the bidder to ensure that the proposed product meets or exceeds every standard set forth in these specifications.
- C. The functions and features specified are vital to the operation of this facility; therefore, inclusion in the list of acceptable manufacturers does not release the System Supplier from strict compliance with the requirements of this specification.

2.2 REMOVAL OF EXISTING PRODUCT

- A. Remove all existing product and deliver to the OWNER, or at the direction of the OWNER, properly dispose of same.
- B. Per National Electrical Code, remove all unused or "dark" wiring utilized by the removed nurse call system.
- C. The OWNER will vacate one nursing unit at a time, making it available on a time table for the installation of the new equipment.
- D. The OWNER will continue to occupy the nursing units where equipment will be replaced. Supplying contractor will need to coordinate work with nursing

administration for each nursing unit to obtain a group of four rooms per day for replacement of equipment. The existing nurse call equipment must be maintained and operational during this replacement period except for the four rooms being renovated.

2.3 NURSE CALL NETWORK WIRING

- A. All Nurse Call Network wiring shall be only CAT 5E or CAT 6. Plenum wire shall be used in open areas and standard CAT 5E or CAT 6 within conduit. System shall be capable of injecting DC power into a CAT 5 or CAT 6 run, for additional rooms, or long runs, by running a separate DC cable pair to a remote location.
 - 1. Contractor shall terminate all wiring with manufacturer approved connectors. Cable terminations shall be installed in accordance to the Installation Guide KI-2093E utilizing a R4KCRIMP crimping tool. Where individual conductors need to be spliced (i.e.: pillow speaker conductors to digital television isolator to 3-conductor cable to television), utilize crimp type connectors. The use of wire nuts is prohibited.
- B. System shall employ a structured cable system consisting of standard 4-pair Category 5E or 6 cable to service all corridor lamps, and consoles.
- C. All Nurse Call Network wiring shall be plenum rated CAT 5E or 6. System shall be capable of injecting DC power into a CAT 5E or 6 run, for additional rooms, or long runs, by running a separate DC cable pair to a remote location.

2.4 NURSE CALL CONTROLLER(S) [note symbol on drawings]

- A. Furnish as needed in each nursing unit a nurse call network controller. Each controller shall provide the following:
 - 1. Non-blocking, duplex communications between consoles and rooms, sub stations and duplex pillow speakers, within each 6 station loop. Provide four loops for a total of 12 dynamically allocated speech paths.
 - 2. CAT 5E or CAT 6 wiring standard utilizing PoE (Power over Ethernet) between console and nurse call controllers and local wiring to power room station equipment and dome lights.
 - 3. VoIP audio to Nurse Call Network, VoIP Nurse Console, VoIP staff terminal, wired or wireless phones via SIP protocol. VoIP digital audio stream out to rooms without IP overhead signaling.
 - 4. Up to 96 corridor lights can be operated with a single controller.
- B. Controller must be life safety grade meaning that it shall not require regular rebooting for continued basic functions of system and it shall be possible for controller to act as a standalone controller should loss of network communication occur. Personal Computers may not be used for this purpose. PCs will only be allowed outside of the UL-listed nurse call network on the customer supported LAN.
- C. Nurse call controller(s) are connected to the hospital's LAN via Ethernet switches. The nurse call servers also connected to the hospital's LAN are running specialized software for using hospital data resources and telephone communications resources.
- D. Make: Rauland Responder 5 Series Model - 351001 (design equipment)

2.5 NURSES MASTER STATION [note symbol on drawings]

- A. Furnish as shown on plans, a UL-1069 listed VoIP nurse console capable of the following functions:
 - 1. Full duplex audio
 - 2. Display up to 3 incoming calls each with an individual elapsed timer which increments time since call was placed. Also provide the ability to scroll to see more incoming calls.
 - 3. Power over Ethernet powered connection to UL-1069 listed Ethernet controller. No local power supplies required.
 - 4. Choice of hands-free duplex communications through built in speaker and separate microphone or private handset conversation.
 - 5. Ability to create up to 32 soft keys, user-configurable.
 - 6. Optional tone/mute of calls in progress.
 - 7. Ability to swing an individual room or any group of rooms by touching one labeled touch point. Room(s) and consoles may be located anywhere within hospital nurse/patient communications network.
 - 8. Console can be programmed to be the receiver of any call that is not answered by another console, or can be programmed to receive any call from a console that has failed or has been unplugged, or otherwise not receiving the call (call orphaning).
 - 9. Self-contained unit which shall not occupy more than 88 square inches of desk space and is desk or wall-mountable.
 - 10. Make: Rauland Responder 5 Series Model - 351205 (design equipment)

2.6 CENTRAL EQUIPMENT CABINET [note symbol on drawings]

- A. Provide a central equipment cabinet for each Area / Unit where shown on the drawings.
- B. Central Equipment Cabinet to house:
 - 1. Power Supplies (Furnish as needed)
 - 2. Battery Backups (Furnish as needed)
 - 3. System Controllers & Switches (Furnish as needed)
- C. Make: Rauland Responder 5 Series Model – NC2828 (design equipment).

2.7 PATIENT STATIONS

- A. Provide single patient [note symbol on drawings] or dual patient station [note symbol on drawings] as shown on plans.
 - 1. Each patient station shall be capable of the following functions:
 - 2. Separate speaker and microphone for full duplex audio. Entertainment audio to be muted when intercom in use.
 - 3. One DIN pillow speaker receptacle per bed that shall have a tilt design, with automatic release of pillow speaker plug when pillow speaker cord is pulled at any angle.
 - 4. Station shall support an optional module to feature bed side rail control on station to indicate the bed is disconnected. LED on station shall indicate that the bed is disconnected and that a bed out call is active.
 - 5. Built in lighting control that interfaces directly to low voltage controllers.
 - 6. One universal 1/4" jack for auxiliary alarm input/call cord per bed. Call priority of these receptacles shall be independent of any other button or receptacle.

7. Cancel button shall cancel any call on this station and any other station in room that is programmed for universal room cancel.
 8. Supply where noted the Enhanced Single Patient Station [note symbol on drawings] that includes all the features above, and additionally, two programmable buttons: code blue and staff assist.
- B. Supply where noted for the Enhanced Single Patient Station an optional Clear Button Cover to prevent accidental initiation of the additional programmable buttons. Cover is easy to install and has an easy to lift cover to access the buttons.
- C. Unit shall mount in a standard 3-gang non-gangable electrical box.
- D. Make: Rauland Responder 5 Series Model – 353000, 353001, & 353010 (design equipment).

2.8 SUB-STATIONS

- A. Provide as shown on plans, sub-stations which shall be flush mounted in a single gang box. All sub-station cancel buttons will follow the cancel policy as defined in the system configuration. Typically canceling a high priority call can only be accomplished by the station initiating a call, while lower priority calls may be cancelled by any associated station in the room.
- B. Individual sub-stations shall be:
1. Pull cord station [note symbol on drawings] shall be water resistant with a replaceable PVC pull-cord, and easily cleaned surface. The pull-cord shall have a large, easy to pull plastic "bell" attached. This station may only be cancelable with the room and not cancelable from the nurse console. Make: Rauland Responder 5 Series Model – 354001(design equipment).
 2. Pull cord station with Call button [note symbol on drawings] shall the same characteristics as above, with the addition of one extra pushbutton for call-in. This button shall be programmable separately from the pull-cord to indicate a different call process (i.e. call caregiver to return to bed) than the pull cord which may indicate an emergency situation. Although this station trims out to a double gang faceplate, the mounting is in a single gang box. Make: Rauland Responder 5 Series Model – 354002(design equipment).
 3. Pull cord station with Speaker [note symbol on drawings] shall have all the capabilities of the pull cord station with call button, and include a built in speaker and microphone for communications with the patient. Although this station trims out to a double gang faceplate, the mounting is in a single gang box. Make: Rauland Responder 5 Series Model – 354000(design equipment).
 4. Single call button station and Dual button stations [note symbol on drawings] shall be water resistant. The buttons shall be back lit and have the ability for a user defined customized call label corresponding to the 990 call priorities available within the system. An elapsed timer may be activated by any call button to start a count up timer on any clock that accepts remote activation. Make: Rauland Responder 5 Series Model – 354011, 354012, & 354015 (design equipment).
 5. Single and Dual call button station can have an optional Clear Cover to prevent accidental initiation of the call buttons. Clear Cover is easily lifted to access buttons and does not cover the Cancel button for easy cancelation of calls. Make: Rauland Responder 5 Series Model – 350008 (design equipment).

6. Staff Registration station [note symbol on drawings] shall have four backlit buttons that allow by default three levels of staff and one Staff Assist Button. Any button can be configured as a staff registration or call button to provide maximum flexibility. Although this station trims out to a double gang faceplate, the mounting is in a single gang box. Make: Rauland Responder 5 Series Model – 354017 (design equipment).
7. Bed Status station [note symbol on drawings] shall have four backlight buttons: Transport, Cleaning Needed, Cleaning in Progress, Bed Ready. The buttons will indicate the room condition and alert transportation personnel to this room. When the Transport button is depressed, the transport person assigned to this area receives a wireless message to transport this patient, or alternately, transportation dispatcher receives an on screen display. Environmental Services staff will receive a wireless message that this bed requires cleaning. Environmental Services and nursing supervisors are alerted to the bed's state. Alternately, customized descriptions can be assigned to this station for specific facility needs. Canceling an event maybe accomplished by pressing a button a second time, using the cancel button, or by pressing another button in the chain of events. Make: Rauland Responder 5 Series Model – 354016 (design equipment).
8. A two jack auxiliary alarm station [note symbol on drawings] shall allow the connection of external patient monitoring devices via two (2) ¼ inch jacks. This allows individual annunciation of patient alarms to nurse call consoles and wireless devices. Each jack may be programmed for one of 990 call processes and may be configured for latching or non-latching. A call in timer may be set within system configuration to buffer a device that produces intermittent alarms. Make: Rauland Responder 5 Series Model – 354018 (design equipment).
9. Remote Tilt Release Pillow Speaker Station [note symbol on drawings] shall provide a remote connection for the standard 9 pin DIN connector associated with a patient station. This allows the remote installation of the patient station, while keeping the 9 pin receptacle close to the patient. Make: Rauland Responder 5 Series Model – 350300 (design equipment).

2.9 CORRIDOR LIGHTS, ZONE LIGHTS, AND DOMELESS CONTROLLERS [note symbol on drawings]

- A. Provide as shown on plans, the proper type of corridor light or domeless controller. Corridor lights shall contain four sections, each lighted by a long life, RGB LED capable of producing 7 colors. Each section shall have a diffusion lens which allows for 180 degree horizontal visibility of call lights. The corridor lights shall be capable of the following:
 1. All segments of corridor light can indicate a call in any of the following 7 colors:
 - a. Blue, Red, White, Green, Orange, Yellow, or Pink.
 2. Custom call patterns (any combination of light segments, such as all segments blue for code blue).
 3. Flash any single color or strobe the sections of the light in any color pattern.
- B. Intelligence in the corridor light and domeless controller shall support up to 16 room devices and allow for the ability of any room station to be associated with any other room in the system. This allows special functions where needed, such as associated call stations and cancelling options, (i.e. door monitoring).

- C. Staff registration shall be indicated by a custom color associated with that staff level (i.e. Green= Nurse, Orange=LPN, Yellow=Aide).
- D. Domeless controllers shall have all the function of the corridor light, less LED's.
- E. In the unexpected event of communications loss with the nurse call controller, corridor lights and domeless controllers shall enter a local room failsafe mode showing all calls in the hallway via the LED indicators.
- F. Corridor lights and domeless controllers may be hot-swapped on the room-to-room communication line without the loss of communications to other devices on the local network.
- G. Make: Rauland Responder 5 Series Model - 352010, & 352021 (design equipment).

2.10 PATIENT ENTERTAINMENT SPEAKER / CALL CORDS

- A. Provide one (1) pillow speaker per bed station unless noted. The pillow speaker shall have a mating 9 pin DIN plug and nurse call button. TV control shall be programmed as a system function to allow pillow speakers to work with any standard hospital grade TV. Lighting control is optional to control up to two lights. All pillow speakers to have call assurance and monitor LED's (specification writer choose one model):
 - 1. Standard Model: Digital TV control with full duplex communications via built in microphone and separate speaker. There shall be three additional buttons for the use by the patient for special needs, such as "pain", "water", and "toilet". The system shall have the ability to discern the difference between these calls and send it to the appropriate care level. Controls for up/down volume, up/down channel. TV mute, closed caption and TV on/off shall be standard. Make: Rauland Responder 5 Series Model - 350227 (design equipment).
 - 2. Enhanced Model: Digital TV control with full duplex communications via built in microphone and separate speaker. There shall be three additional buttons for the use by the patient for special needs, such as "pain", "water", and "toilet". The system shall have the ability to discern the difference between these calls and send it to the appropriate care level. Controls for up/down volume, up/down channel. TV mute, closed caption and TV on/off shall be standard. A direct entry key pad gives patient ability to enter channel number. Make: Rauland Responder 5 Series Model - 350207 (design equipment).
 - 3. Basic Model: Analog TV control with pillow speaker audio for communications and TV audio. Provide buttons for TV channel change/ON-OFF and volume control potentiometer. Make: Rauland Responder 5 Series Model - 350242 (design equipment).
- B. Provide one (1) call cord per bed station unless noted. The call cord shall have a mating 9 pin DIN plug and nurse call button.
- C. Make: Rauland Responder 5 Series Model - 350100 (design equipment).

2.11 STAFF STATION [note symbol on drawings]

- A. Provide as shown on plans as staff station. Unit shall provide two-way hands free duplex intercom to its assigned nurse console(s) by pushing a call in button. Station shall support an optional module to feature bed side rail control on station

to indicate bed connection. LED on station shall indicate bed connection. Unit shall mount in a standard 3-gang electrical box.

- B. Make: Rauland Responder 5 Series Model – 353101 (design equipment).

2.12 DUTY STATION [note symbol on drawings]

- A. Provide as shown on plans as duty station. Unit shall provide remote annunciation of assigned patient stations and sub-stations via 4 LED's and multiple call tones. Duty station faceplate LED's shall mimic corridor light activity for the assigned nursing area. Also provides two-way duplex intercom to the assigned nurse console(s) through separate speaker and microphone. Call tones generated at duty station must be identical and repeat in synch with tones produced at closest nurse console. It shall be possible to mute the call in tone, without cancelling call. The next call in, assigned to this duty station, will un-mute the station. Muting feature may be defeated in those jurisdictions that do not allow muting of duty station. The duty station shall be capable of being programmed for a specific time that a day/night mode takes place, allowing a volume change to the call-in tones. This feature is required to minimize noise for patients. Unit shall mount in a standard 3-gang electrical box.
- B. Make: Rauland Responder 5 Series Model – 353100 (design equipment).

2.13 STAFF TERMINAL [note symbol on drawings]

- A. Furnish as shown on plans, as part of the nurse call communications network, a UL 1069 listed VoIP Staff Terminal. This dynamic device shall serve as a patient or procedure room communications tool while providing staff with "soft" touch-points to initiate an instantaneous notification of an in-room need. Additionally this terminal may be used as a functional nurse call console.
- B. The following functions shall be provided:
 1. Color touchscreen display.
 2. Ability to create up to 60 soft keys, user-configurable, up to 8 screens per terminal.
 - a. Sends specific need for that location. Examples: Emergency, Staff Assist, Cleaning Needed, Lifting Help, Transport, Order, Stat Order, Rounding, etc.
 - b. Speed dial to any location
 3. Power over Ethernet powered connection to UL-1069 listed Ethernet switch. Local power not required.
 4. Full duplex audio
 5. Hands-free duplex communications through built in speaker and separate microphone.
 6. Display up to 3 incoming calls each with an individual elapsed timer which increments time since call was placed. Also provide the ability to scroll to see more incoming calls.
 7. Ability to dial through touch key pad.
 8. Ability to capture an individual nursing unit, selected units, or all units in hospital by touching single custom labeled touch point.
 9. Ability to Bi-Directionally interface to the EMR in order to allow Staff Terminal workflow events to be logged in the EMR and have EMR events (i.e. Fall Risk) activate workflow in the Staff Terminal including corridor light illumination, call placement and wireless messaging.

- C. Make: Rauland Responder 5 Series Model – 351310 (design equipment).

2.14 SPARE PARTS

- A. Provide the following spare parts:

ITEM	QUANTITY
(Enhanced) Single Patient station	2
Pull cord station	2 of each type used
Push Button station	2 of each type used
2 Jack station	2 of each type used
Pillow speaker – call cord	4 of each type used
Console	1
Staff Terminal	1

- B. Turn spare parts over to Owner and obtain a signed receipt. Submit receipt for review.

PART 3 - PRODUCTS – SOFTWARE

3.1 PC CONSOLE DISPLAY – Optional

- A. Provide a PC console display on any networked OWNER provided PC that meets the system manufacturer’s minimum specifications, whether it utilizes touch screen or standard mouse control. Also, OWNER provided wall mounted PC displays shall have the global option provided in this software package of a touch screen keyboard.
- B. The following additional functions shall be provided at each one of these users’ screens:
1. Full display of all calls, including corridor light color sequence.
 2. Complete electronically generated census of patients showing assigned caregiver, current patient needs as sent by service reminder process, time patient has been waiting for call answering, or need, list of caregivers on duty and staff location.
 3. Customizable views including 1 window with 8 columns, 2 windows with 4 columns, and 3 windows with 3 columns.
 4. Ability to text message to any single individual, group of users, or all users, a text message to a wireless phone display.
 5. Ability to display calls in a centralized display format (i.e. Centralized Code Blue display).
 6. Ability to display and route calls in a de-centralized workflow environment.
 7. Ability to display all staff information, staff status, wireless extension and their location.
 8. Ability to initiate a room status or call from the PC console.
- C. Provide software to make caregiver to patient assignments from any OWNER provided PC workstation within the hospital by easy user sign on. Assignment

process shall be intuitive and indicate to that Supervisor making the assignment, each caregiver's patient load based on number of patients and patient difficulty. These assignments shall stay in queue until each individual signs on duty. The assignment is released when the caregiver goes off duty.

- D. The following additional functions shall be provided:
1. Unlimited assignment of caregivers to patients, patients to caregivers.
 2. Group assignments.
 3. Assignments may be made up to 7 days in advance.
 4. Easy display of prior day's assignment and easy click to accept if you want to keep assignment the same.
 5. Display pertinent HL7 fields for patient.
 6. Allow for assigning advanced call escalation for un-answered calls.
 7. Staff member shall have ability to use Bar Code for ID and wireless devices.
 8. User's assignment can print out to a local printer.
 9. User shall have the ability to go ON and OFF break forwarding their device to another caregiver and reflecting this activity in the reporting software.
 10. Put staff on and off duty and assign a phone.
 11. Conduct device based assignments as well as staff based assignments.

3.2 WIRELESS DEVICE INTERFACES – Optional

- A. The Telephone Interface shall receive, via an Ethernet connection, VoIP connectivity using the standard SIP protocol. This module shall support at least 60 simultaneous voice connections between wired/wireless phones and the nurse call network. There shall be four different possibilities (specification writer choose one method):
1. The facility will utilize a VoIP/SIP wireless phone system and an IP/SIP PBX. The software module shall directly support an interface through the OWNER provided Telephony/SIP Call server that communicates to the nurse call network gateway server. Any nurse call system that only utilizes analog station/trunk ports to communicate with SIP wireless phones will not be acceptable.
 2. The facility will utilize a VoIP/SIP wireless phone system with a non-SIP PBX. The software module shall directly support an interface through the OWNER provided Telephony/SIP Call Server that communicates to the nurse call network gateway server. OWNER will also provide a Telephony/SIP Gateway. Any nurse call system that only utilizes analog station/trunk ports to communicate with SIP wireless phones will not be acceptable.
 3. The facility will utilize a wireless phone system which is not SIP compatible and a VoIP/SIP PBX. The software module shall directly support an interface through the OWNER provided Telephony/SIP Call Server that communicates to the nurse call network gateway server. The supplying contractor is to provide middleware which interfaces the non-SIP wireless phone system display to the nurse call system software module. OWNER provides wireless phone system OAI. OWNER will also provide a Telephony/SIP Gateway.
 4. The facility will utilize a wireless phone system which is not SIP compatible and a non-SIP PBX. The software module shall directly support an interface through the OWNER provided Telephony/SIP Call Server that communicates to the nurse call network gateway server. The supplying contractor is to provide middleware which interfaces the non-SIP wireless phone system display to the nurse call system software module. OWNER provides wireless phone system OAI. OWNER will also provide a Telephony/SIP Gateway.

- B. Wireless SIP interface will allow for the display of the patient name attached to an incoming nurse call event.
- C. SIP devices will have the ability to escalate nurse call events from the handset.
- D. SIP integration must differentiate between a status notification and a patient call.

3.3 ADT INTERFACE – Optional

- A. Provide a HL7 compliant interface for the purpose of receiving relevant patient information.
- B. This interface shall be capable of the following:
 - 1. Mapping of standard ADT segment field components and subcomponents to nurse call fields.
 - 2. All updates shall be real time, but software shall buffer data for any interruption of service.

3.4 LOCATION INTERFACE (RTLS -Real Time Locating System) – Optional

- A. Provide an interface (OAI) to integrate with the facilities Real Time Locating System (specified or provided elsewhere) and the nurse call network. Nurse call features and location of staff shall communicate per standard API published by manufacturer of nurse call.
- B. The full integration shall include, but not be limited to the following:
- C. Staff location.
- D. Ability to choose specific calls to be canceled as a staff member walks into room.
- E. Optionally lights corridor light to show staff in room with specific staff color.
- F. Ability to locate staff throughout the facility on networked PC.
- G. Reporting on said functionality

3.5 REPORTING SOFTWARE – Optional

- A. Provide software that may be accessed by any networked PC work station that gives management patient call details in clear readable format. HL7 integration shall make all pertinent patient details available, including the ability to search by patient name and/or patient ID number for those nurse call records associated for that patient during their stay, regardless of room/bed occupied. All reports shall be fully historical.
- B. In addition, the reporting software shall provide the following functions:
 - 1. Standard, global reports
 - 2. Summary reports
 - 3. Detailed reports
 - 4. Graphic reports
 - 5. Productivity reports
 - 6. Staff coverage reports
 - 7. Reports shall be viewed in Adobe Acrobat Reader
 - 8. Any trained individual may utilize standard ODBC compliant reporting software to generate more enhanced reporting.

9. Does not require additional off-the-shelf software for the generation of reports.
10. Uses SQL Reporting Services for report generation.

PART 4 - EXECUTION

4.1 NEEDS ASSESSMENT

- A. Manufacturer shall provide a one-on-one meeting with the particular nursing manager of each unit affected by the installation of the new networked nurse/patient communications equipment. This meeting shall include reviewing the floor plan drawing, educating the nursing manager with the functions of the equipment that is being provided and gathering details specific to the individual units; coverage and priorities of calls; staffing patterns; and other pertinent details that will affect the training. In-service Scheduling materials and sample of training materials will be provided. A staff member list, if needed, will be filled out for inclusion in the software. Information gathered will be provided to Contractor to program the network software.

4.2 INSTALLATION, EQUIPMENT

- A. Contractor shall terminate all wiring with manufacturer approved connectors. The use of wire nuts is prohibited.
- B. All wiring shall be free from shorts and faults. Wiring shall be UL listed, NEC and NFPA 70, Article 25 approved.
- C. Nurse patient communications network wiring shall not be run in the same conduit with other systems (i.e. Class 1 AC power distribution, fire alarm, entertainment systems, lighting controls, etc.).
- D. It shall be the responsibility of the Electrical Contractor to provide a dedicated 120 VAC, 60 HZ conduit feed into the equipment cabinet. This power feed shall not have any other devices connected directly to it. A 20 AMP circuit breaker located in the electrical sub-panel labeled "nurse call" will control this circuit. This electrical circuit will be connected to the hospital's emergency power system for automatic power switch over during loss of utility power.
- E. Large hospital systems may require multiple equipment cabinets that are separated between floors and buildings.

4.3 IN-SERVICE TRAINING

- A. Manufacturer shall provide thorough training of all nursing staff assigned to those nursing units receiving needs assessment of new networked nurse/patient communications equipment. This training shall be developed and implemented to address all types of staff determined at the needs assessment. Floor nurses/staff shall receive training appropriate to their needs, and likewise, unit secretaries (or any person whose specific responsibilities include answering patient calls and dispatching staff) shall receive operational training appropriate to their needs and charge nurses (or any person whose specific responsibilities include scheduling staff to patient assignments) shall receive operational training appropriate to their

needs. A separate training room will be set up if available that allows this type of individualized training utilizing in-service training unit.

- B. Provide a minimum of [] hours of instruction to the nursing staff and operating personnel, schedule in advance.

4.4 TESTING

- A. Submit a written test report from an authorized representative of the equipment manufacturer that each device and overall system operation has been 100% tested.
- B. Provide 2 sets of keys to all equipment cabinets and submit a receipt for review.
- C. Submit [] bound Operator Manuals that shall include as a minimum:
 - 1. Bill of Materials.
 - 2. Manufacturer's equipment description for each type of device and control module type used.
 - 3. Provide record wiring diagrams showing typical connection diagrams for each type of device and a complete riser diagram showing all devices, zones, and wiring requirements, as installed. Wiring diagrams shall show terminal connections at the central equipment cabinet.
 - 4. Instruction report stating when instruction was given and who was in attendance, signed by those given instruction.
 - 5. Manufacturer's authorized representative written test report.
 - 6. Statement of warranty called for.

END OF SECTION

SECTION 27 53 19

DISTRIBUTED ANTENNA SYSTEM

PART 1 - GENERAL

1.1 RELATED DOCUMENTS

- A. American National Standard ANSI/TIA/EIA Telecommunications Building Wiring Standards.
- B. Drawings and general provisions of the Contract, including General and Supplemental Conditions and other Division 1 Specification Sections, apply to this Section
- C. 232123Section 01 81 13 "Sustainable Design Requirements – LEED v4 for Building Design & Construction – New Construction" for sustainable design requirements and detailed sustainable design submittal requirements.
- D. Section 01 74 19 "Construction and Demolition Waste Management and Disposal" for disposal of construction, demolition and packaging waste disposal requirements.

1.2 SUMMARY

- A. The Maine Medical Center MMC (the Owner) is developing new facilities at the East Tower 6 & 7 Building in Portland, Maine. A Distributed Antenna System (DAS) is included in the new installation.
- B. This specification describes the technical and performance criteria for a Neutral-Host Distributed Antenna System (DAS) capable of supporting Wireless Service Providers (WSP's) initially with the capability to support Public Safety Networks (PSN) in the future by the addition of PSN-specific active and passive components (including EMI filtering) without modifications to the basic passive portions (coverage antennas, optical fiber, coax cabling, splitters, connectors, etc.) of the DAS infrastructure.
- C. This Section specifies requirements for furnishing, installing and testing the DAS, including all required parts, cabling and components required to provide a fully operational system that meets all technical and functional requirements and is ready for the Owner's use
- D. The DAS shall provide coverage for the WSPs initially and PSNs at a future date, (to be determined), on all frequencies currently being used by the designated WSPs and PSNs in the vicinity of the hospital, including: Verizon Wireless, AT&T Wireless, T-Mobile and Sprint, as well as designated PSNs. The DAS shall also be capable of future expansion to accommodate future 2300 MHz and 2500 MHz WSP frequency bands by the addition of 2300/2500 MHz-specific active and passive components without modifications to the basic passive portions (coverage antennas, optical fiber, coax cabling, splitters, connectors, etc.) of the DAS infrastructure
- E. RELATED SECTIONS
 - 1. Refer to the following specification sections for coordination and scope definition
 - a. Section 271300 – Backbone Cabling
 - b. Section 271500 - Communications Horizontal Cabling
 - c. Section 270526 – Grounding and Bonding for Communications Systems

d. Section 271100 – Communications Equipment Room Fittings

F. Sustainable Building Requirements:

1. The Owner requires the Contractor to implement practices and procedures to meet the project's environmental performance goals, which include achieving LEED version 4 **Certified** level Certification. Specific project goals that may impact this area of work include: use of recycled-content materials; use of locally-manufactured materials; use of low-emitting materials; construction waste recycling; and the implementation of a construction indoor air quality management plan. The Contractor shall ensure that the requirements related to these goals, as defined in the Articles below, are implemented to the fullest extent. Substitutions, or other changes to the work proposed by the Contractor or their Subcontractors, shall not be allowed if such changes compromise the aforementioned environmental goals and LEED certification.

1.3 ABBREVIATIONS

- A. ACG - Automatic Gain Control
- B. AHJ – Authority(ies) Having Jurisdiction
- C. ATP - Acceptance Test Plan
- D. AWS - Advanced Wireless Service
- E. BDA - Bi-Direction Amplifier
- F. BOM - Bill-of-Material
- G. BRS - Broadband Radio Service
- H. BTS - Base Transceiver Station
- I. CDMA - Code Division Multiple Access
- J. C/N - Carrier-to-Noise Ratio
- K. CWDM - Coarse Wave Division Multiplexing
- L. DAS - Distributed Antenna System
- M. DWDM - Dense Wave Division Multiplexing
- N. EBS - Educational Broadband Service
- O. ESMR - Enhanced Specialized Mobile Radio
- P. FCC - Federal Communications Commission
- Q. GUI - Graphical User Interface
- R. iDEN - Integrated Enhanced Digital Network
- S. LMR - Land Mobile Radio
- T. LTE - Long Term Evolution
- U. MHz – Millions of Hertz
- V. MTBF - Mean Time Before Failure
- W. MTTR – Mean Time to Repair
- X. NFPA - National Fire Protection Association

- Y. NMS - Network Management System
- Z. PCS - Personal Communications System
- AA. PSN - Public Safety Network
- BB. ROF - Radio Over Fiber
- CC. RoHS - Restriction of Hazardous Substances
- DD. RSL -Received Signal Level
- EE. RSSI – Received Signal Level Indication
- FF. SISO - Single-Input, Single-Output
- GG. SMR - Specialized Mobile Radio
- HH. SMS - Short Message Service
- II. SNIR - Signal-to-Noise Interference Ratio
- JJ. SNMP - Simple Network Management Protocol
- KK. SOW - Statement of Work
- LL. VSWR - Voltage Standing Wave Ratio
- MM. WSP - Wireless Service Provider

1.4 DEFINITIONS

- A. Acceptance – Expressed approval by the Owner
- B. Active Components - DAS components that require AC/DC power for operation
- C. Carrier Approval - Expressed approval by WSP to connect to WSP network
- D. Channel – a path for RF communications
- E. Component – a main element of the DAS
- F. EMI - Electromagnetic interference
- G. RCDD - Registered Communications Distribution Designer
- H. Owner – Maine Medical Center
- I. Passive Components – DAS components not requiring AC/DC power for operation
- J. RCDD - Registered Communications Distribution Designer

1.5 SCOPE OF WORK

- A. Design, furnish, configure, install and test the new DAS as indicated on the Contract Drawings including as required, but not limited to: Donor Antennas, Coverage Antennas, Coax Cable, Coax Connectors, Splitters, Combiners, Couplers, Fiber-Optic Cable, Fiber-Optic Connectors, and Fiber-Optic Jumpers, Bi-Directional Amplifiers (BDAs), Fiber-Optic Master Unit and Fiber-Optic Remote Units.
- B. Design and install the DAS to be fully be fully capable of receiving WSP and PSN approval for interoperation with their respective networks.
- C. Negotiate on behalf of the Owner all required retransmission agreements with WSPs

- D. Assist the Owner in negotiating any potential cost and revenue sharing agreements with WSPs
- E. When prior approval of the PSN deployment is required by code or ordinance, assist the Owner with obtaining all required approvals from authorities having jurisdiction
- F. Obtain on behalf of Owner any required licenses or permits associated with the DAS installation and operation
- G. Note that some of the work required for the DAS will be provided by others. Review Contract Documents and coordinate with Owner and other contractors to ensure that there is no unnecessary duplication of effort or interference with other portions of the work.

1.6 SYSTEM DESIGN AND PERFORMANCE REQUIREMENTS

- A. All work, including but not limited to: wiring, equipment, installation, workmanship, maintenance and testing shall comply with the latest editions of the National Electrical Code, National Electrical Safety Code, all applicable local rules and regulations, equipment manufacturer's instructions, and the National Electrical Contractors Association (NECA) Standard of Installation. In case of conflicts among the requirements noted above, the contractor shall satisfy the most stringent requirements.
- B. Requirements set forth by first-responder code, ordinance, or the PSN Authorities Having Jurisdiction shall supersede the requirements described herein and shall be met in their entirety. It is the Contractor's responsibility to ensure that the DAS complies with local code, ordinances or requirements established by the PSN authorities.
- C. The DAS architecture shall employ an active optical backbone between the DAS headend and distributed remote units. Horizontal distribution from remote units to coverage antennas shall be entirely passive.
- D. The system shall be capable of future modifications and upgrades within the specified frequency bands without disturbing the passive portions of the system:

Service	Uplink, MHz	Downlink, MHz
Cellular	824 - 849	869 - 894
PCS	1850 - 1920	1930 - 2000
AWS	1710 - 1780	2110 - 2180
WCS (Future)	2305-2315	2350-2360
Commercial 700 Bank	698 - 716, 776-787	728 - 746
Narrow Band Public Safety 700 Band (Future)	799 - 817	769 - 775
800 Band	806 - 824	851 - 869
BRS/EBS (Future)	2496 - 2690	

- E. The downlink Received Signal Level for each frequency band shall meet or exceed the following over 95% of the interior spaces:
 - 1. Lower 700 MHz, BRS/EBS: -75 dBm
 - 2. Cellular, PCS, AWS, Commercial 800/900 MHz: -85 dBm
 - 3. Public Safety (future) 380-512, 700, 800 MHz: -95dBm
- F. The DAS shall have capabilities to support the following WSPs deployed in a SISO antenna environment as well as the following Narrow Band PSN and VHF/UHF frequencies without changes to the passive DAS infrastructure. Any additional active

components required for system expansion shall comply with all specifications of this Section.

1. AT&T Wireless
2. Verizon Wireless
3. T-Mobile
4. Sprint

- G. The DAS shall have a Network Management System (NMS) capable of alarm, monitor, configuration and control of all active components. The DAS NMS shall be capable of integration with 3rd party SNMP based NMS products for alarm purposes

1.7 REFERENCES

A. Military Standards

1. MIL-C-17 - Standards for Radio Frequency Coaxial Cables

B. Telecommunications Industry Association (TIA)/Electronic Industries Alliance (EIA):

1. 1568-B - Commercial Building Telecommunications Cabling Standard.
2. 569 - Commercial Building Standard for Telecommunications Pathways and Spaces
3. 222-H - Structural Standard for Antenna Supporting Structures and Small Wind Turbine Structures.

C. Institute of Electrical and Electronics Engineers (IEEE):

1. SO/TR 21730:2007 - Use of mobile wireless communications and computing technology in healthcare facilities - Recommendations for electromagnetic compatibility with medical devices.

D. Underwriters Laboratories Inc. (UL):

1. 910 - Test for Flame - Propagation and Smoke - Density Values for Electrical and Optical-Fiber Cables Used in Spaces Transporting Environmental Air
2. 1581 - Reference Standard for Electrical wires, Cables and Flexible Cords
3. 1666 - Test for Flame Propagation Height of Electrical and Optical - Fiber Cables Installed Vertically in Shafts
4. 1685 - Standards for Safety Vertical Tray Fire Propagation and Smoke Release Test for Electrical and Optical Fiber Cables
5. National Public Safety Telecommunications Council (NPSTC)
6. Best Practices for In-Building Communications

1.8 SUSTAINABLE DESIGN REQUIREMENTS

- A. Provide Energy Star and Restriction of Hazardous Substances (RoHS) compliant components meeting the requirements of this Section, as available

1.9 QUALITY ASSURANCE

- A. Perform all equipment and cable installation using qualified workers with prior experience in installing active and passive radio frequency equipment, optical fiber cable, copper cable, operating software and low voltage power supplies. Work experience shall include the successful installation of at least three other DAS Installations of similar scope and complexity to the Work of this Contract. In addition, at least one of the installation contractor employees shall hold a current BICSI RCCD certification and be certified by the equipment manufacture(s) in the installation and testing of the proposed DAS

- B. Equipment and software manufacturers shall be regularly engaged in manufacturing DAS equipment and associated products of the types, sizes, and characteristics specified in this section and on the Contract Drawings.
- C. All components of each kind shall be the product of a single manufacturer.
- D. Radio system equipment shall be electromagnetically compatible (EMC) and not cause electromagnetic interference with other systems.

1.10 SUBMITTALS

- A. As applicable, submit the following prior to beginning work:
 - 1. Manufacturer datasheets for the following components:
 - a. Donor and Coverage Antennas
 - b. Coaxial Cable and Connectors
 - c. Splitters, Combiners and Couplers
 - d. Bi-Directional Amplifiers (BDA)
 - e. Optical Fiber Cable and Connectors
 - f. Fiber-Optic Master Unit
 - g. Fiber-Optic Remote Units
 - h. Power Supplies, UPS, Batteries
 - i. Racks and Cabinets
 - 2. Contractor's System Warranty.
 - 3. Manufacturer's Extended Warranty.
 - 4. Maintenance Service Contract
 - 5. Acceptance Test Plan and test equipment to be used
 - 6. Shop Drawings:
 - a. RF link budget
 - b. Cable route diagrams for all cabling
 - c. Plans and elevations of all major equipment, racks, components and devices
 - d. Antennas and mounting details
 - e. Indoor propagation/coverage maps demonstrating compliance with coverage requirements Hardware and software manuals
 - f. Detailed product specifications
 - g. Mean Time Between Failure (MTBF) data for each Active Component
 - h. Independent test results verifying the product specifications
 - i. For active components serving the WSP's, written documentation from the WSP's that the component(s) are approved for use within the WSP's networks
 - j. Signal to Noise Interference Ratio (SNIR) Map
 - k. Bill-of-Material (BOM)
 - 7. Comprehensive Acceptance Test Plan including proposed testing procedures and specification of test equipment.
 - 8. Any requirements for Owner-provided infrastructure, networks, servers or software
 - 9. Current BICSI RCCD Certification
- B. Submit Record Documents at completion of work:
 - 1. Field test reports indicating and interpreting test results including certified final test reports for all DAS equipment and cable runs and certification of all test equipment used for testing.

2. One reproducible set and four sets of prints of the Shop Drawings that reflect the actual as built condition of the entire DAS.
 3. Four sets of system parts, maintenance and operation manuals.
 4. System scheduled maintenance requirements.
 5. A complete list of recommended spare parts, which shall include those spare parts required to be furnished in compliance with the requirements of this Section.
- C. DELIVERY, STORAGE, AND HANDLING
1. Deliver to the worksite all equipment, components, cabling and hardware properly packaged in factory-fabricated packaging.
 2. Store all equipment, components, cabling and hardware in clean dry space in original containers, protected from weather, theft, vandalism, damaging fumes, construction debris and traffic.
 3. Handle equipment, components cabling and hardware carefully to avoid braising, damage or undue wear.

PART 2 - PRODUCTS

2.1 MANUFACTURERS

- A. Acceptable manufacturers of DAS passive and active components (as applicable) include: Andrew/CommScope, Bird Technologies, Comprod, Belden, Corning, Times Microwave, RFS, Trilogy Communications, EMR Corp, JMA Wireless, Cobham, Galtronics or functional equivalent subject to compliance with requirements of this Section and prior approval by the Owner.
- B. No alternative component(s) shall be accepted as equal to the components and manufacturers specified in this document unless they are of equal or superior specifications and quality, and that they have been used in similar projects of size and complexity for no less than 3 years.

2.2 WARRANTY

- A. Manufacturer Warranty:
- B. Splitters, Couplers, and Coverage Antennas: 5-year warranty from date of system acceptance.
- C. Coaxial Cable and Connectors: 10-year warranty from date of system acceptance.
- D. Fiber-Optic Cable: 20-year warranty from the date of system acceptance.
- E. Active Components: The earliest of 1-year warranty from date of system installation or 15 months from date of shipment.
- F. Contractor Warranty: Contractor shall warrant the system performance as specified herein for one year.

2.3 QUALITY CONTROL

- A. Factory inspection. The owner shall have the right to inspect the manufacturer's quality control, manufacturing, and testing facilities at any time during the procurement process. Inspection may include visual examination of the equipment,

cables and all related documentation to ensure that the system is being fabricated in accordance with the specifications.

- B. Manufacturer shall maintain ISO Quality Control registration for the facilities that manufacture the products used in the DAS.

PART 3 - EXECUTION

3.1 PREPARATION

- A. Examine raceways and other equipment spaces to receive cable and equipment for compliance with installation tolerances and other adverse conditions. Do not proceed with installation until unsatisfactory conditions have been corrected.
- B. Refer to Contract Documents to define work provided by others and work to be provided by this Contractor.

3.2 INSTALLATION

- A. Comply with manufacturer's requirements and written instructions. Observe manufacturer's requirements for bending radius, pulling force and support intervals. Install all cable connectors in accordance with manufacturer's instructions using manufacturer's recommended tools. Weatherproof all coaxial connections using manufacturer's recommended weatherproofing kit.
- B. Install cable and equipment in locations as shown on the Contract Drawings by experienced workers in a careful professional manner.
- C. Make variations to indicated antenna locations as needed to ensure required RF performance.
- D. Restore fire rating of all interior wall and floor penetrations. Seal and weather proof all exterior wall and roof penetrations.
- E. Use CMR and CMP rated cables as applicable

3.3 ACCEPTANCE TESTS

- A. After installation of the system, the Contractor shall perform the field acceptance tests:
- B. All tests shall be performed by the Contractor and witnessed as required.
- C. All equipment, personnel and supervision necessary to conduct the tests shall be provided by the Contractor.
- D. All test results shall be recorded and reports delivered to the Engineer upon completion of the tests.
- E. The entire installation shall be inspected for conformance to this Section and code requirements. Non-conforming installations shall be corrected prior to the start of testing at no additional cost to the Authority and reported to the Engineer.
- F. Thirty days prior to the field test specified hereinafter submit a comprehensive testing plan to the Engineer for review and approval. The testing plan shall include testing

procedures approved by the Engineer and any additional tests required by the Engineer.

- G. The entire installation shall be tested to show compliance with this Section. The Contractor shall perform any repairs or modifications required to comply with the test requirements at no additional cost to the Owner. Testing shall continue until all results are met to the requirements of this Section and to the satisfaction of the Owner.
- H. Each designated coverage area shall be divided into a grid of approximately twenty (20) equal areas. Locate a spot approximately in the center of a grid area for the test. Once the spot has been selected, prospecting for a better spot within the grid area will not be permitted. Test each grid area will for transmission/reception. Measure and record individual channel signal levels. Measure and record individual channel signal levels at the portable input port. If signal strength fails to meet the requirement, the grid area shall be marked as a fail. If the 95% area coverage requirement is not met, adjust the system to meet requirements.

END OF SECTION

This page is intentionally left blank.

SECTION 28 10 00

SECURITY SYSTEM

PART 1- GENERAL

1.1 RELATED DOCUMENTS

- A. Drawings and general provisions of the Contract, including General and Supplementary Conditions and Division 1 Specification Sections, apply to this Section.
- B. Section 01 81 13 "Sustainable Design Requirements – LEED v4 for Building Design & Construction – New Construction" for sustainable design requirements and detailed sustainable design submittal requirements.
- C. Section 01 74 19 "Construction and Demolition Waste Management and Disposal" for disposal of construction, demolition and packaging waste disposal requirements.

1.2 SUMMARY

- A. This Section includes the electronic Access Control, Intrusion detection and CCTV Video System and Video Management System.
- B. Card holder information/enrollment existing.
- C. Related Sections include the following:
 - 1. Division 16 Section "Raceways and Boxes."
 - 2. Division 16 Electrical Sections
 - 3. Division 08
 - 4. Division 27
- D. The work covered by this specification includes the construction described, including all labor necessary to perform and complete such construction; all materials and equipment incorporated or to be incorporated in such construction; and all services, facilities, tools and equipment necessary or used to perform and complete such construction.
- E. Provide the following:
 - 1. Furnish, install, terminate, test and document new electronic access control system, including proximity card readers, door contacts, request to exit devices, control panels, cabling, software and interface with Owner's networks/central station and integrated with local fire alarm system. ALL MECHANICAL DOOR HARDWARE IS FURNISHED & INSTALLED BY OTHERS. COORDINATE WITH ARCHITECT. Security Contractor is responsible for final terminations.

2. Furnish, install, terminate, test and document new electronic alarm system, including door and window contacts, PIR motion detectors, duress alarms, tamper switches, aural and visual alarm enunciators, control panels, cabling, software and interface with Owner's networks/central station and local fire alarm system.
3. Furnish, install, and terminate, test and document new IP CCTV system, including cameras, camera mounts, camera power supplies, digital video recorders, monitors, cabling and all other required components.
4. Access Control Software House server existing. (C-Cure 800)
5. CCTV Server/Video management existing (ONSSI)
6. It is the intent of these design/build specifications to procure a complete, workable and programmed Security System, compatible with the Owner's planned and existing systems and ready for the Owner's use. Any item not specifically shown on the drawings or called for in the Specifications, but normally required to conform to the intent, is to be considered as part of the Contract.
7. Any given item of equipment, material or software shall be the product of manufacturers indicated within this specification or approved equal, throughout the facility. Multiple manufacturers of any one item shall not be permitted, unless specifically noted otherwise or approved by the Owner.
8. These Specifications are equipment and performance Specifications. Any discrepancies found between the Specifications and Drawings shall be brought to the attention of the Consultant. Installation and details indicated on the Drawings shall govern if they differ from the Specifications.
9. Bidders are encouraged to proposed alternative solutions that are fully compliant with the Client's requirements.
10. Certain terms such as "shall, provide, install, complete, etc." are not used in some parts of these Specifications. This does not indicate that the items shall be less than completely installed or that systems shall be less than complete.

F. Sustainable Building Requirements:

1. The Owner requires the Contractor to implement practices and procedures to meet the project's environmental performance goals, which include achieving LEED version 4 **certified** level Certification. Specific project goals that may impact this area of work include: use of recycled-content materials; use of locally-manufactured materials; use of low-emitting materials; construction waste recycling; and the implementation of a construction indoor air quality management plan. The Contractor shall ensure that the requirements related to these goals, as defined in the Articles below, are implemented to the fullest extent. Substitutions, or other changes to the work proposed by the Contractor or their Subcontractors, shall not be allowed if such changes compromise the aforementioned environmental goals and LEED certification.

1.3 SUBMITTALS

- A. Submit manufacturers' product data sheets for all material and equipment products proposed in bid. Only specified or accepted manufacturers or suppliers shall appear in the product data submittal.
- B. Provide physical samples of products if requested by Consultant.

- C. Where substitutions or alternates are requested for any specified manufacturer or product, submit complete documentation for the product proposed, including complete product data and catalog cut sheets, engineering test and performance reports and any other information pertinent to the product.
- D. Submit shop drawings for review ten (10) days prior to start of work and prior to ordering of material to consist of one (1) set of reproducible and three (3) sets of prints of drawings, diagrams, and/or manufacturers' data in accordance with the contract documents.
- E. At completion of installation, furnish a complete set of as-built documents, including plan view and elevation drawings, device schedules, test and acceptance documentation, equipment manuals and operating instructions.
- F. As-built drawings shall consist of one (1) set of reproducible and three (3) sets of prints, and one (1) computer format CD.

1.4 QUALITY ASSURANCE

- A. Electrical Components, Devices, and Accessories: Listed and labeled as defined in NFPA 70, Article 100, by a testing agency acceptable to authorities having jurisdiction, and marked for intended use.
- B. Comply with NFPA 70, "National Electrical Code."
- C. Comply with applicable SIA Industry Standards.
- D. Codes, Regulations And Standards
 - 1. Comply with the most recently issued requirements, standards, recommendations, rules, and regulations of authorities having jurisdiction over the project.
 - 2. Follow the most restrictive code or recommendations. Where there are ambiguities, refer to the Consultant for interpretation.

PART 2 - PRODUCTS

2.1 GENERAL

- A. Provide the products called out below and on drawings or approved equal. Where a specific manufacturer has not been called out, provide industry standard products of first quality and fully compatible with the system.
- B. All equipment shall be equal to or exceed the applicable minimum requirements of NEC, IEEE, ASME, ANSI and UL.
- C. All products and materials shall be new, clean, and free of defects or damage and of first quality.
- D. Coordinate device quantities, locations, types and finishes with architect.
- E. The work covered by this specification includes the construction described, including all labor necessary to perform and complete such construction; all materials, software and equipment incorporated or to be incorporated in such construction; and all services, facilities, tools and equipment necessary or used to perform and complete such construction.

2.2 ACCESS CONTROL SYSTEM (Existing)

- A. Furnish & Install a PC-based Access Control Management System (ACMS) detailed below, complete with all hardware necessary for a complete and functional system. The system shall have ample capacity to accommodate future growth, integrate with the fire alarm system and shall have an open architecture which allows importing and exporting of data from other applications. The system shall be capable of stand-alone operation. Provide the following components:
1. The SMS shall be an integrated system that utilizes a single, industry-standard relational database management system for the storage and manipulation of related data. The SMS shall include a server with operating system and applications software, operator and administrator terminals with appropriate software, hard copy printers and fixed magnetic storage media. The security devices shall communicate with the field panels via a dedicated cable network. The field panels shall communicate to the server via a Fast Ethernet 10/100, TCP/IP network or a serial (RS-232, RS-485) connection.
 2. The SMS shall employ a standard Windows 7, Windows 2003 Server, or later graphical user interface (GUI). A mouse and keyboard shall be the primary operator interface with the system. Operator screens shall utilize all standard Windows-style functions such as drop-down menus, context menus, radio buttons, and lists, as appropriate. The interface shall utilize a 'tree structure' similar to Windows Explorer.
 3. The ACMS shall be flexible and scalable in architecture, permitting expansion of both capacity and functionality, to be implemented progressively as needed, through software licensing and/or software upgrades.
 4. The ACMS shall employ distributed processing technology, allowing the host to function almost entirely as an application/database server. The majority of the real time, day-to-day decisions shall be made locally by intelligent control panels. The control panels shall be the direct field interface for all access control, alarm sensing, and input/output-controlled devices.
 5. The ACMS shall manage and automatically download in real-time, all database changes made at all operator workstations, to the control panels that require notification of the specific database changes or updates.
 6. The SMS hardware shall be comprised of modular components that connect over standard interfaces to one another. There shall be a Data Gathering Unit storage and processing module (DGU), and once data has been downloaded to the DGU it shall locally make access control decisions. Access granted or denied decisions shall be made in under 0.5 seconds
 7. The DGU shall store firmware in non-volatile flash memory to allow for convenient updates through the head-end software application. The DGU shall store the cardholder and configuration database information in battery-backed memory so that loss of primary power will not cause the loss of the database.
 8. The DGU shall support configurations that include: 16 card readers, 96 monitored input points, or 32 auxiliary output points.
 9. There shall be an intelligent controller option to provide control of 8 readers/doors from a single circuit board (communications, memory, CPU, and reader/door functions integrated) with an available 8-reader/door add-on to provide a 16-door controller from two circuit boards. The 8-door controller shall provide an integrated on-board RS-232 interface, and shall have provisions for modular expandable memory.

10. There shall be an option for hardware made with a lead-free manufacturing process to meet RoHS requirements.
11. Communication Schemes
 - a. Hardwired Communications
 - 1) The field panels shall be located convenient to the access and monitor points that they control, and shall be interconnected in a chain configuration to a serial port of a convenient client PC on the system.
 - 2) The system shall support a minimum of 31 intelligent field panels (nodes) daisy-chained together such that they communicate back to a single serial communications port at the host.
 - b. Bi-Directional Communications
 - 1) A chain of field panels shall be wired in a loop configuration, by the addition of a cable from the last controller and connecting it into a second port on the PC. When this configuration is installed, should a break in the cable occur, the PC shall be able to communicate with the nodes after the break, via the secondary port.
12. Network Communications
 - a. The first field panel in a chain of panels shall have the ability to communicate with its monitoring client PC over the local or wide area network. This shall be achieved by the addition of a network interface option module and provide a cost effective alternative configuration to a direct connection via a client PC's serial port. The network interface shall support both "10 base T" and "100 base TX" (10/100) communications speeds. The network interface shall support encryption utilizing either TwoFish or AES algorithms.
 - b. An optional modem and telephone line shall be configured to provide an alternative path for the reporting of alarms. The fallback to dial-up alarms reporting shall be automatic in the event of detecting a network communications failure.
13. Efficient Memory Management
 - a. Controllers shall be capable of supporting cardholder populations of at least 200,000, or be configured to a learning mode that allows the cards most frequently used to have their access rights stored locally in the panel's memory.
 - b. When a card is presented which is not resident in the local panel, a verification request shall be made to the central database, if the card is valid the details shall be downloaded. If the card memory is full, the card with the oldest transaction date shall be deleted to make space for the card requested. This shall allow automatic management of cardholders, based upon frequent users having "instant" response and infrequent users learned when required.
14. Database Synchronization
 - a. To ensure synchronization of the distributed controllers' databases with a region's main database an internal checking process shall be provided within each controller. In the event of corruption of a controller's local database then it shall be able to detect this condition and automatically request the relevant data to be downloaded from its local server. This action shall not require Operator intervention.
 - b. The system shall continue to provide access control functionality during this re-synchronization process.

15. Door lock release relays shall be minimally rated for 3 A @ 30 VDC.
16. Readers supporting various technologies shall provide data from card presentations or biometric authentications through a door control unit (DGP) that includes the electrical interface to the reader as well as inputs for door sensors and form C relays for outputs.
17. The DGP shall support Wiegand communications to the reader. In order to provide higher levels of security, the DGP shall support bi-directional, supervised, and encrypted communications to the reader. Door controllers that do not support encryption and supervision of reader communications are not considered equal.
18. The system shall support an option to store cardholder biometric information (e.g. fingerprint or hand geometry templates) at the panel (as part of the cardholder record). Storage of the template data at the reader shall be unacceptable. An acceptable alternative is to store individual templates on secure smart cards.
19. The SMS hardware shall support all of the following options for supervision of the monitored input points:
 - a. 2-state supervision – in which only secured and alarm state are indicated.
 - b. 3-state supervision – in which the input state can be secure, alarm or open circuit.
 - c. 4-state supervision – supports secure, alarm, short circuit and open circuit states.
 - d. 6-state supervision – supports secure, alarm, short or open circuit for the sensor in addition to tamper alarm and tamper short circuit states.
20. High Availability and Disaster Recovery (Provide as alternate)
 - a. To provide greater client software availability, software shall be installed so that in the event of a database server failure, client machines will quickly and without operator intervention, automatically connect to a standby server machine.
 - b. This configuration shall utilize the industry standard Microsoft clustering solution and allow for an installation with a large number of client machines, the ability to continue to operate without interruption, while the cause of the main server failure is investigated.
 - c. The SMS product shall be capable of supporting options for 99.99% and 99.999% availability.
21. Bandwidth Utilization
 - a. The proposal shall include documented manufacturer's evidence of network bandwidth utilization including plots and supporting data, covering all aspects of normal system operation. Proposal submissions without supporting documentation will not be considered or evaluated.
22. Encryption
 - a. Encryption falls into two distinct areas, firstly between clients and their Server, secondly between client and local area network panels (LAN Nodes).
 - b. LAN node links shall support Two Fish and AES encryption between the supervising client PC and its LAN Chains.
 - c. For client to server connections, the SMS shall support a solution using industry standard network cards, such as the Intel Pro 100s, which support IPsec and 3DES encryption.
 - d. Web-based (thin client) SMS clients shall use 128-bit SSL encryption.
23. Required Standard Software Features

- a. The following software features shall be part of the standard product offering without requiring additional purchase or licensing.
 - b. The installation of the server and client software shall utilize a "wizard" interface to guide users through the appropriate installation steps.
 - c. The SMS shall start up as part of the Operating System. The SMS shall run as a service in the OS, and there shall be no requirement to run an application after the operating system is ready.
 - d. The SMS shall support a Graphical User Interface that minimizes training needs for even inexperienced users. The software shall include on line help displays to eliminate operator reference manuals.
24. It shall be possible to select any function, within a given Operators permission, independent of the currently displayed screen. Functions will be accessed via tool bar Icons, which will include help prompts that will appear when the mouse pointer dwells on the selection button. It shall also be possible to link any standard Windows application to a custom toolbar icon.
25. A print screen command icon shall be provided, subject to an individual Operator's permission, for all screens and will allow the currently displayed information and screen presentation to be printed.
26. The system shall support an unrestricted number of time codes. Furthermore, the system shall support a minimum of 10 intervals per time code.
27. The SMS shall support an unrestricted number of time intervals. A time interval is a defined span of time such as "08:00 to 17:00" as "Business Hours". Time intervals shall be permitted to span midnight, such as "20:00 to 05:00" as "Third Shift".
28. The system shall be scalable to a multiple-server implementation where each region (either geographical or logical) has a server capable of making local decisions and configuration changes. The Global head-end server responsible for managing the entire enterprise including all regional servers shall support a minimum of 999 regional servers.
29. Operator Permissions
- a. System operators shall be associated with a log in Name and Password. A system option will determine whether strong operator passwords will be used. The minimum definition of a strong password shall be a password that contains at least one upper case character, one lower case character, one numeral and one punctuation mark, with a minimum password length of six characters. Additionally the password cannot contain any full word of the operator's username.
 - b. The option to use a Secure Biometric or Smart card for system logon shall be provided. When used, this option will force the operator to present their Name, Password and Biometric or Smart card.
 - c. Operators shall be assigned to permission profiles. This will determine the functions that will be available to that operator when logged-on to the system. Each operator is required to only see the functions for which s/he has access. The system shall support an option to hide Personal Identification Numbers of cardholders when an operator is viewing a record.
 - d. Card record data entry shall be divided into operator permission areas, allowing separate permission categories to be assigned for the viewing of personal data, ID badge printing and access right management.
 - e. The SMS shall support an unrestricted number of operators and operator permission profiles.

- f. For all operators, a means of re-arranging their Icon tool bar shall be provided to allow the most frequently used Icons to be repositioned by the operator.
 - g. The system shall store operator preferences based on logon information. This feature shall allow an operator to work with their preferred configuration independent of which workstation they occupy.
30. Operator Interface
- a. The SMS shall use a single client application interface for system configuration, administration, management, and monitoring operations.
 - b. The SMS shall provide a mouse-driven, java-based, graphical user interface allowing operator(s) to open and work on multiple windows simultaneously, at host server and client workstation(s) with minimal degradation to system performance.
 - c. The SMS shall provide a Web Browser based client-less interface that is capable of accessing the system from any authorized computer on the network regardless of the client computer operating system without requiring the loading or maintenance of any client software. The Web Browser interface must support industry standard SSL 128bit encryption.
 - d. The ACMS shall provide on-line context sensitive help files to facilitate operators in the configuration and operation of the ACMS.
 - e. The ACMS shall implement National Language Support (NLS) in a manner that allows simultaneous multi-lingual operation, based on individual operator language preference.
 - f. The ACMS shall support defining an unlimited number of operators; application access via workstation(s) shall be restricted by operator login and password. Operator profiles shall be configurable to include form level and field level permissions, database partition views, and language preference.
 - g. The ACMS shall provide primary and secondary menus that lead to input forms (screens) to add, change or delete information.
 - h. All ACMS forms shall support custom forms and templates that can be created based on an existing record or modifying a blank record.
 - i. All forms can be customized to include the fields and tabs of the operator's choice and be set as a default
 - j. The templates can then be used to generate new records with the necessary links already set up.
 - k. The ACMS shall provide the capability to create custom lists to appear on the operator's forms to satisfy specific requirements – such as a list box of company or division names
 - l. The ACMS shall provide definable templates for configuration wizards allowing an operator to create master templates for generating new records with the necessary links predefined
 - m. When a template is run, a Wizard guides the operator through the necessary steps to create a new record for the form
 - n. The system shall support generation of reports detailing the system operation. The following reports shall be available in the software:
 - 1) Cards on site
 - 2) Hours on site
 - 3) Cardholders with access to each door
 - 4) Access rights of each cardholder
 - 5) System Configuration

- 6) Scheduled and Conditional Commands defined
- 7) System operator transaction history
- o. It shall be possible to replay video clips associated with events by directly interacting with the report as published to the computer screen.
- p. The system shall demonstrate the ability to export data, for example reports, to other standard office word processing packages such as Microsoft Word.
- q. The system shall provide system management reporting, including detailed listings for all the operator actions and the current cardholder database for output to the display screen, printer or disk media.
- r. The system shall have the ability to save frequently used report configurations and associate them with a "Title". Such predefined reports shall be available from a list to simplify the report selection. It shall be possible to request these reports to run immediately or schedule them to occur at a specified date and time.
- s. Scheduled reports shall additionally have the option to be automatically repeated by specifying the number of days and reporting period to be included, for example a weekly report of Alarms to run at 10:30 am each Monday and including the previous 7 days of Alarms.
- t. The system shall allow custom reporting options by providing an interface to a commercially available 'off the shelf' reporting product, such as Crystal Reports. The interface shall present all database fields in a structured format, which does not require detailed knowledge of the database design and table relationships.
- u. History Reporting
 - 1) Extensive reporting shall be included to provide the ability to review all system alarms, access control activity and operator actions. These reports shall be available for review on the operator's display, to a printer, or to a file.
 - 2) Extensive sort parameters shall include any of the personal details fields of information such as by department, job title, vehicle registration, contractor company name or any other reference appropriate for each site.
 - 3) Frequently run report configurations shall be saved allowing them to be selected and run on demand, or scheduled to run automatically as required. When scheduled to run automatically this shall have the ability to be repeated.
 - 4) Total Hours Spent On-Site
 - a) This report shall provide a detailed audit of the arrival and departure times for cardholders and calculates the total time spent on site for the chosen reporting period. This report shall be filtered by any of the personal data fields of information associated with each cardholder.
 - 5) Cards On-Site Reporting
 - a) This report shall provide a list of cardholders currently on the site. This may be for all persons within the site or just who, for a particular department or a particular contractor company, is currently present. The report may also be run to cover just a part of the site, for example, cardholders is in a particular building or room.

31. The SMS server shall communicate to all clients (operator workstations and field hardware) through WIN32 services. The SMS server shall not require that an application be run for proper system operation.
32. Clients
 - a. The system shall support an unrestricted number of clients to suit growing enterprise requirements. The system shall provide the means for multiple operators to simultaneously administer the system from convenient locations connected via a local area network (LAN) or across a wide area network (WAN).
 - b. Systems that operate on the MSDE database server that restrict the number of clients shall be upgradeable to a fully unrestricted version of the software without the need for a database conversion.
 - c. Clients shall not use mapped drives for server connections.
 - d. Clients shall not use UDP messaging.
 - e. System shall support a minimum of two client pc monitors. The system shall additionally store the last position and size of all open dialog boxes and screens upon exiting the application on a per operator basis. The next time the operator logs into the application, the screen positions shall be restored. Such operation shall be independent of which workstation the operator uses.
33. Addition of Cardholders to the System Database
 - a. The system shall provide a means of assigning access control rights to each cardholder. Access control rights determine which access points are accessible to the cardholder based on date and time of day. The system shall support an unrestricted number of access rights.
 - b. The software shall also provide an ALTERNATE set of Access rights to a cardholder on a temporary basis. The change may be initiated at any time by an authorized operator, or automatically between specified dates. This shall provide the facility of automatically changing a card's rights between a specified date range, after which the card will revert to its normal Doors and Times. Alternate access rights shall be able to be configured for multiple date ranges.
 - c. Each cardholder shall either be associated with standard door timings, for door release, door open and door pre-held or be given extended timings for disabled persons or someone who has to push a cart.
 - d. Cardholders who have not used a reader for some time shall be readily listed to allow their card's status to be reviewed. An additional feature shall allow cardholders to be automatically set inactive and therefore access denied should the card have not been presented at any reader on the system for a defined number of days.
 - e. Cardholders shall be assigned an expiration date, and more specifically an expiry time, after which a card shall automatically become inactive and therefore be rejected at all readers on the system. To further simplify card administration, the system shall have the ability to be configured to automatically purge expired cardholder records after a configurable number of days from the date of expiration.
 - f. The system shall allow for the definition of Access control rights to be associated with a badge design. Each user that selects that badge design shall be provided with the associated access control rights that can further be customized for the specific cardholder.

- g. The system shall allow access control rights to be defined for a cardholder on a reader basis. A time code will be associated with each reader as it is assigned to the cardholder's access control rights.
 - h. The system shall allow access control rights to be defined for a cardholder on a reader group basis. Reader groups are groups of readers. A timecode will be associated with each reader group as it is assigned to the cardholder's access control rights.
 - i. The system shall allow access control rights to be defined for a cardholder on an access code basis. An access code is a group of access control rights.
 - j. The system shall have a note field associated with each cardholder record. The note field shall be free form text and shall support a minimum of 256 characters. The note field shall further support the ability to attach a file (of any type or size) to the cardholder record.
 - k. When viewing a cardholder record the last twenty-five (25) valid door access transactions shall be displayed to help locate a cardholder.
 - l. A driver's license scanner shall be supported to simplify data entry of cardholder information. The scanner support shall include, at a minimum, the ability to automatically read, through optical character recognition, the most common fields from valid driver's licenses issued by all 50 states; and populate these fields into the appropriate user-defined personal data fields in the cardholder record.
 - m. The system shall support a field for assigning an approving official to the cardholder record that defines the individual who authorized the assignment of a credential. Approving officials shall have an associated validity period and image of their signature. As an option, the assignment of an approving official shall be mandatory.
 - n. The SMS shall allow the user to enroll biometric data as part of the cardholder enrollment process. The number of verifications to determine applicability of the enrolled biometric data shall be configurable.
34. Cardholder Details
- a. Cardholder information shall include first and last name, card number, PIN code and valid period to provide automatic expiration. Each cardholder record shall also incorporate at least 50 user-defined personal data fields, independent of user-defined fields for visitor management.
 - b. Data entry shall be simplified by remembering previous entries of personal data and allowing selection from a pick list to minimize repetitive typing when creating each cardholder's record. The cardholder database and the history log shall also be sorted by any of the additional fields of information making them a powerful tool for filtering data.
 - c. Personal data fields shall support free entry text, picking an entry from a previously configured list, or picking an entry from an updatable list. Each of these entries shall further be categorized as a date, a time, general input, or customized input. Each category shall support the masking of input data to assure data integrity. For instance, a date mask might look like "mm/dd/yyyy" to indicate that the date input should be a two-digit month followed by a two-digit day followed by a four-digit year all separated by the slash character. The mask shall be required for customized input.
 - d. Personal data fields shall have the option of being configured as mandatory.

35. Locator
 - a. This feature shall provide a quick method of locating cardholders by displaying the last 25 valid history events along with the time, date and access point used. This information shall be available for an individual or group of persons by name, card number or by personal data.
36. Card Watch Feature
 - a. Any cardholder shall be easily tracked as they move around a large site by selecting card watch. As the person uses their access control card, the system shall have the ability to automatically notify the operator of the person's presence at each location.
37. Key Card Mode
 - a. Key card mode authority shall be assigned to special cardholders, such as site key holders, and can be enabled on a per reader basis. This shall allow a person when vacating an area or building to change the reader's mode of operation from normal access control to Key Card Out operation.
 - b. When in this condition only persons with key card privileges shall gain access through the door, all non-key card users are rejected regardless of their card's current access rights.
 - c. This special feature shall be activated/deactivated by the key cardholder, using a card swipe followed by a special code entered via the reader's keypad.
38. Serial Device Interface
 - a. The software shall allow the definition of ASCII commands to be sent out over a computer serial port (physical or virtual) or through the RS-232 interface of the DBU. These serial commands shall be available through the user interface as well as in the conditional logic described herein.
39. Automatic Holiday Override
 - a. The software shall be programmed by the operator to recognize special or holiday dates, which in turn can be linked to operational changes in how the site is to be managed on these specific days. This feature shall notify a system operator of individual holiday dates up to seven days prior provides a useful check on the date's current validity. Multiple types of holiday dates shall also be provided so that partial days or early closing requirements on specific dates can be accommodated.
 - b. The SMS shall provide a calendar function to enable scheduling of events up to five (5) years into the future.
 - c. The SMS shall provide the ability to schedule one-time events for up to five (5) years into the future.
40. System Partitioning
 - a. The access point readers, monitor points, and auxiliary outputs shall be managed on a partition basis by simply defining which devices are to be included in a partition.
 - b. The SMS shall support an unrestricted number of partitions.
 - c. Multiple private or public entities shall be able to share the system with database segregation for card records and ownership of readers, monitor point inputs and switching outputs dependent upon the operator's assigned permissions. Each company partition shall allow for autonomous system administration, allowing partitioned card administration, reports, and alarms.

- d. Operator permissions shall be created and assigned globally or by the owning company. When created and assigned globally an Operator's password shall be associated with one or more companies.
 - e. Alarm reporting shall be routed to a client located at the company owning the monitor point or reader and can be automatically redirected to a different PC at pre-programmed times and selective days of the week.
 - f. Common areas, such as the main entrance, shall have the ability to be shared so that all companies may access these doors, even when different card customer/site codes have been configured.
41. Alarm Management
- a. Alarm handling shall be efficiently managed with up to 99 priority levels and user definable instruction messages to ensure the operator monitoring the site takes appropriate responses. The facility shall have the ability to customize audible alerts for each type of alarm is provided using standard or custom generated multimedia wave files. Each alarm type shall also be presented in a user-defined color.
 - b. To provide additional information when reviewing alarm signals, the operator shall either enter custom comments or simply select from a predefined pick list to provide a time-stamped record of all the actions taken throughout the incident. Predefined manual commands shall be uniquely assigned for each alarm, and readily activated by the operator via a command button provided on the alarm acknowledgement screen. Additionally automatic conditional commands shall be configured to automatically operate in response to any given alarm condition.
 - c. The SMS shall be optionally configured to require operator comments when acknowledging alarms.
 - d. The SMS shall support the ability to selectively choose alarms to acknowledge and/or clear.
 - e. Each alarm shall be configurable to have a specified color and sound.
 - f. Each alarm shall be capable of linking video from digital video recorders (if applicable) for incident playback.
 - g. The Alarm Monitor screen shall provide an indication that cardholder information is available for a specific alarm. A "Card" button shall be available that when pressed will display the cardholder badge image.
 - h. Alarm monitor screen shall support the display of alarm statistics, shall provide up to ten alarm filters to be displayed in different tabs on the alarm screen, and shall provide the ability to sort based on each different column.
 - i. Each alarm shall be time-stamped in the local time zone (not the server time zone), and the system shall support the additional display of labels associated with different geographical time zones such as PST, EST, GMT, etc. The labels for time zones shall be customizable.
 - j. The system shall permit the routing and display of real time activity at any standard client machine. Activity shall be shown in a dedicated activity window that is updated automatically when new transactions occur. This option shall not be limited to routing transactions to one location and shall support the simultaneous routing and display of real time activity at multiple locations.
 - k. Alarms shall be capable of being routed to specific client machines by time of day or day of week.

- k. The map display shall include the option to display a group of similar devices as a single icon. Once devices are grouped it shall be possible to change their status. For example, it shall be possible to unlock all entrance doors by executing a single command from the map display.
43. Manual and Automatic Commands
- a. Operators shall be provided with a wide choice of manual commands embracing the control of readers, monitor points, output switching relays and door locking devices. Also the operator shall have the ability to check the status of single, or multiple devices. This shall ensure the operator is always able to check the operational status of the system and make any adjustments as requirements change. When graphical maps are utilized, status requests shall be simply initiated by "clicking" on the device icon within the map. This functionality shall be capable of being restricted per device based on operator permission.
 - b. Automatic commands shall be included and may operate on a timed or event basis.
 - c. Scheduled commands shall easily be defined linking complimentary commands to occur at the start and stop times of any chosen timecode.
 - d. Event triggered commands shall provide an extremely powerful means of creating IF/THEN/WHEN associations encompassing a wide selection of IF conditions to the automatic execution of THEN commands subject to a WHEN timecode being active. A minimum of 10 THEN actions shall be available per trigger command.
 - e. Devices shall be managed on a partition basis by grouping readers, monitor points and auxiliary outputs. This feature shall allow multiple devices to be actioned by a single command when using manual, timed and conditional commands. This functionality shall be capable of being restricted per device based on operator permission.
 - f. The SMS shall support an unrestricted number of automatic (scheduled and trigger) and manual commands. These commands shall be capable of spanning across multiple field controllers.
44. Card Initiated Commands
- a. The software shall allow authorized cardholders to initiate powerful trigger commands manually from selected reader locations when certain models of readers are used in conjunction with the field panels.
 - b. Up to 99 predefined commands shall be invoked by an authorized card allowing, for example, a patrolling guard to switch on outputs, disable monitor points, lock doors, providing remote management of the system during a patrol of the site.
 - c. The system shall only permit assigned users to enter command codes at keypad readers. Such assigned users shall not be restricted as to when or where they can enter a command code – such restrictions may be placed on the commands themselves.
 - d. User Code Mode
 - 1) The SMS shall support the ability to put a keypad-equipped reader into User Code Mode. This feature shall allow a cardholder to gain access by entering a valid card's number at a reader keypad, therefore not requiring the holder to carry a card.
 - 2) User code mode shall be enabled on a per reader basis.
 - 3) This mode shall support card number only, or card number and its assigned PIN code.

45. Device Configuration
 - a. The system shall support a notes field to be associated with each device configured on the system. The notes field shall be free-form text, and shall support a minimum of 256 characters. The notes field may be used for detailed device descriptions or for maintenance history. The notes field shall also allow files to be associated.
 - b. The system shall provide a hierarchical tree view of the system configuration supporting expansion and collapse of any and all branches.
46. Windows Daylight Saving Auto Adjustment
 - a. The system shall support Windows Time Server or Windows time management.
47. History Archive and System Back up
 - a. The system shall allow on line archiving of history logs, along with database back up of system configuration and cardholder details. To further ease the burden of remembering to back up your system's database, this function shall be able to be automated to occur without intervention at a pre-set time.
 - b. The system backup and history archive shall be to a magnetic tape drive at the database machine, or the system may be configured with a destination drive and path located on a different PC accessible to the Database machine via the network.
48. Anti-Passback
 - a. The system shall support both "hard" Anti-Passback and "soft" Anti-Passback alarm reporting modes.
 - b. If the cardholder has access rights at a reader, but creates an Anti-Passback alarm, if the reader configured as hard anti pass-back sends an Anti-Passback alarm and denies access to the door/portal.
 - c. Soft anti pass-back sends an Anti-Passback alarm, but still allows access through the door/portal.
 - d. The system shall support timed anti-pass back. The principle of timed anti pass-back is simple: once a card has been used at a timed anti pass-back reader, the card causes an Anti-Passback violation if it is used again at the same or another timed anti pass-back reader within a predefined period of time. The exception to this rule is when the Anti-Passback reader has been defined to be for an exit route. In this case, the card can be used at any time without causing an alarm or event. This allows for situations where a person enters an Anti-Passback protected area, then wishes to exit the area immediately, perhaps, for example, because he or she forgotten something.
 - e. The use of an exit anti-pass back reader also causes the time delay for reuse of the card to be zeroed, so in the example, the person can re-enter the anti-pass back-protected area immediately, without having to wait. The delay can also be zeroed from the Card Holders screen or by means of an anti-pass back command. Sending a command may be useful if, for example, people have passed through an exit during a fire drill and the delay is long.
49. Provide Manufacturer:
 - a. Software House C-Cure 800
 - 1) Access Panel: ACP (8 Door Controller)
 - 2) Model #: As required by the owner

12. Card Reader Cabling (Composite-Plenum)
 - a. Manufacturer: CSC Cable, West Penn, Windy City Wire
 - b. Part #: CSC P/N:112110 (Plenum)
 - c. Part #: West Pen P/N:AC251822 (Plenum)
 - d. Part #: Windy City P/N: 4461095-S (Smart Wire-4 Plenum)
 - C. Miscellaneous Materials. Provide all cabling, connectors, mounting hardware, interface modules, software, manuals, instructions and miscellaneous items necessary for a complete, fully installed and functional system, ready for the Owner's use. ALL MECHANICAL DOOR HARDWARE SHALL BE FURNISHED BY OTHERS (electric locks, magnetic door strike, strikes, etc.). Security contractor responsible for final terminations.
 - D. Labeling and documentation of all cables, boxes, devices, and hardware installed under this contract.
 - E. Testing and test documentation as described below.
 - F. Ancillary Devices. Key pads, PIR detectors, panic buttons, door contacts, glass break detectors (audio type) etc. shall be compatible with specified the alarm panel or the approved equal. All devices and finishes shall be coordinated and approved by the architect prior to installation.
 - G. Miscellaneous Materials. Provide all cabling, connectors, mounting hardware, interface modules, software, manuals, instructions and miscellaneous items necessary for a complete, fully installed and functional system, ready for the Owner's use.
 - H. Labeling and documentation of all cables, boxes, devices, and hardware installed under this contract.
 - I. Testing and test documentation as described below.
- 2.3 VIDEO MANAGEMENT SYSTEM (VMS) (Existing)
- A. Furnish & Install all IP CCTV hardware as depicted on drawings, or approved equal, complete with all hardware necessary for a complete and functional system. The system shall have ample capacity to accommodate future growth. Provide the following components:
 1. Performance Requirements
 - a. Complete IP CCTV video recording management solution in a compact design.
 - b. Capable of high resolution H.264 video compression.
 - c. Provide system wide recording, monitoring, and management of fixed and PTZ cameras.
 - d. Simultaneous live display, recording, playback, network transmission, and back-up.
 - e. Stable embedded operating system.
 - f. Rack mountable.
 2. Field replaceable hard drives, accessible via the front without uninstalling the unit from the application.
 3. The VMS shall have flexible, open architecture built on accepted industry standards that facilitate integration with IT infrastructures.

- a. Flexible and scalable IP CCTV management system in an easy to use versatile design.
 - b. View, record, control cameras, handle alarms and check device status through one interface.
 - c. Real-time digital recording and playback at 25/30 IPS in CIF, 2CIF and 4CIF resolution on all channels simultaneously.
 - d. Real-time live display at 25/30 IPS in 4CIF resolution for greater detail as needed (independent of recording settings).
 - e. Multiple control options via USB mouse, front panel and joystick keyboard.
 - f. Remote configuration and management of devices on surveillance system.
 - g. Powerful search and playback functions.
 - h. Hybrid recording of 8 or 16 analog cameras and up to 16 H.264 IP channels with a variety of hard drive capacities.
 - i. Internal storage up to 8 TB on four front-accessible hard drives.
 - j. Lip-Synchronous audio/video.
 - k. Video player with image authentication (watermarking).
 - l. NTSC and PAL selectable video format (auto detected).
4. Field replaceable hard drives, accessible via the front without uninstalling the unit from the application.
 5. The VMS shall have a distributed fault-tolerant, failover database architecture. The distributed server architecture allows for each subsystem to operate in an independent mode, without affecting video recording or live viewing.
 6. The database video storage shall provide minimum of 20 days of high quality at 7.5 fps 2 CIFF resolution quality. The overall storage shall be based on real time recording and motion detection no less that 50 percent of motion activity and H.264 compression scheme.
 7. The VMS shall possess an internal watchdog to detect and recover from the unlikely occurrence of system lockup.
 8. The VMS shall provide support for IP (network) cameras from multiple third party manufacturers.
 9. The VMS shall not use multiplexing or timed division technology for analog video recording. All analog camera sources shall be digitally recorded.
 10. The VMS shall be able to support video motion detection natively. This operation can be executed by the edge device or the IP Camera. Enabling motion detection shall be performed either:
 - a. On a continuous basis
 - b. Scheduled for particular times, dates, days, months, etc.
 - c. Defined areas of interest through an easy-to-use user interface using simple editing tools
 - d. At a defined level of sensitivity
 11. The VMS shall support local language translation, including languages that do not support the European character set, such as Chinese.
 12. All text displayed in the user interface shall be stored in a database to allow for easy translation to another language.
 13. The VMS shall support both single and multi-site deployments.
 14. The VMS shall be designed to work with cameras that generate a standard NTSC or PAL composite video signal.
 15. The VMS shall support a variety of video matrix switcher devices, code generators, and PTZ cameras from different manufacturers.

16. The recorders will use a standard Ethernet connection for video input via TCP/UDP/IP.
17. The VMS shall be capable of supporting large organizations with systems at multiple site locations linked via LAN / WAN connections.
18. Provide the following components:
 - a. Helipad - Full 360 Degrees PTZ Network Camera
 - 1) Manufacturer: AXIS Comm. (PTZ Control Camera)
 - 2) Part # AXIS Q6000-E Mk II PTZ Four 2-MP
Sensors and wall mount kit or approved equivalent
 - b. Helipad - Outdoor PTZ Dome Network Camera
 - 1) Manufacturer: AXIS Comm. (PTZ Dome Control Camera)
 - 2) Part # AXIS Q60-E PTZ HDTV 1080P & 32x Optical Zoom
And wall mount kit or approved equivalent
 - c. Med Room - Fixed Dome Network Camera
 - 1) Manufacturer: AXIS Comm. (PTZ Dome Camera)
 - 2) Part # AXIS P3225-LVE Mk II HDTV 1080p Video Quality
Streamlined and wall mount kit or approved equivalent
 - d. Flexible Multi-Sensor Network Camera
 - 1) Manufacturer: AXIS Comm. (Flex., 360 Degree Multi Sensor)
Part # AXIS P3707-PE 8MP and 360 Degree,
Multi-Sensor Camera and ceiling mount kit or approved equivalent.
 - e. Fixed Dome, Multi-Sensor, Multi-Megapixel Network Camera
 - 1) Manufacturer: AXIS Comm. (Fixed Dome Camera)
Part # AXIS Q3709-PVE 180 Degree Overview,
3x4K at 33MP resolution and wall mount kit or approved equivalent.
 - f. Door Entry and Gate Control
 - 1) Manufacturer: TALKAPHONE Grand Stream PBX System
 - 2) Part # AVM-1 (Grand stream GXV3275)
IP Video Attendant Phone
Wall mountable. Integrated stand with two (2) adjustable angles.
 - g. Door Entry and Gate Control
 - 1) Manufacturer: TALKAPHONE Compact IP Call System
 - 2) Part # VOIP-200C (Flush mount configuration)
VOIP-201C (Surface mount configuration)
 - h. Power Supplies and battery backup
 - 1) Manufacturer: Altronix
 - 2) Part # R2432UL (Rack Mount)
Or approved equivalent
 - i. UPS
 - 1) Manufacturer: Tripp

- 2) Part # 3KVA Smart Pro tower and rack Mount
Or approved equivalent

- j. Cabling (Coaxial and Power)
 - 1) Manufacturer: CommScope
 - 2) Part # 2054K/2054V
Or approved equivalent

- k. Video Network Recorder/VMS (Existing)
 - 1) Manufacturer: ONSSI
 - 2) Part # IP Licenses as required

- l. Encoders for analog cameras (Elevator)

- m. Video Transceivers
 - 1) Manufacturer: NVT
 - 2) Part #: NV-214A-M
 - 3) Part #: 8-channel Video Transceiver Hub Model NV-813S
Or approved equivalent

- n. POE Network Switch
 - 1) Manufacturer: Interlogix
 - 2) Part # 24 Port Switch Giga bit Ethernet Managed switch
POE on all 24 Ports 15.5 watts/port, 2 x 1 GB
backbone 4 x SFP ports copper.

- o. CCTV Monitors
 - 1) Manufacturer: Bosh
 - 2) Part #: LCD 26" High Definition Monitor Model # UML-262-90

- 19. Ancillary Devices such as cameras, lenses, camera mounts, camera enclosures, recorders, switch gear, etc. shall be compatible with the overall system design intent. All devices and finishes shall be coordinated and approved by the architect prior to installation.

- 20. Miscellaneous Materials. Provide all cabling, connectors, mounting hardware, interface modules, software, manuals, instructions and miscellaneous items necessary for a complete, fully installed and functional system, ready for the Owner's use.

- 21. Labeling and documentation of all cables, boxes, devices, and hardware installed under this contract.

- 22. Testing and test documentation as described below.

- 2.4 RELATED WORK NOT INCLUDED IN THIS SECTION AND SPECIFIED ELSEWHERE, UNLESS OTHERWISE NOTED.
 - A. Electrical outlets.
 - B. Standard electrical boxes with ¾-in conduit stub ups to ceiling.
 - C. Cutting, patching, and painting.

2.5 WARRANTY

- A. Warranty all portions of the work against faulty and improper material and workmanship for a minimum period of one (2) year from date of final acceptance by the Owner. Where warranty for a longer term is offered through a manufacturer/installer certification program, such longer term shall apply.

PART 3 - EXECUTION

3.1 EXAMINATION

- A. Examine pathway elements intended for cables. Check raceways, cable trays, and other elements for compliance with space allocations, installation tolerances, hazards to cable installation, and other conditions affecting installation.
- B. Examine roughing-in for cable conduit systems to PCs, Controllers, card readers, and other cable-connected devices to verify actual locations of conduit and back boxes before device installation.
- C. Proceed with installation only after unsatisfactory conditions have been corrected.

3.2 GROUNDING

- A. Comply with Division 16 Section "Grounding and Bonding."
- B. Comply with IEEE 1100, "Power and Grounding Sensitive Electronic Equipment."
- C. Ground cable shields, drain conductors, cabinets and equipment to eliminate shock hazard and to minimize ground loops, common-mode returns, noise pickup, cross talk, and other impairments.
- D. Bond shields and drains conductors to ground at only one point in each circuit.

3.3 LABELING/IDENTIFICATION

- A. In addition to requirements in this Article, comply with applicable requirements in Division 16 Section "Electrical Identification" and with TIA/EIA-606.
- B. Label each terminal strip and screw terminal in each cabinet, rack, or panel.
 - 1. All wiring conductors connected to terminal strips shall be individually numbered, and each cable or wiring group being extended from a panel or cabinet to a building-mounted device shall be identified with the name and number of the particular device as shown.
 - 2. Each wire connected to building-mounted devices is not required to be numbered at the device if the color of the wire is consistent with the associated wire connected and numbered within the panel or cabinet.
- C. At completion, cable and asset management software shall reflect as-built conditions.

3.4 FIRE STOPPING

- A. Seal all penetrations through fire rated walls, floors and walls created by or made on the behalf of the contractor so that the original fire rating of the floor or wall is maintained as required by Article 300-21 of the National Electric Code.

- B. Use sealant material that has passed fire exposure testing in accordance with standard time-temperature curve in the standard, UL, ASTM E 119, and NFPA 251 and the hose stream test in accordance with UL 10B.

3.5 TESTING

- A. Test all components installed under the contract.
- B. Pre-installation Inspection
 - 1. Visually inspect items and shipping cartons for damage. Return visibly damaged items to the manufacturer.
 - 2. Prior to testing, submit for review and approval copies of test report forms proposed for use. Forms shall, at minimum, contain: Project name; Contractor's name; Date of test; Type and description of test, and test criteria for acceptance.
- C. Post Installation Testing
 - 1. Submit Test and Acceptance Plan to owner for approval prior to testing.
 - 2. Test only completed systems. Partial testing is not acceptable.
 - 3. The Consultant reserves the right to observe the conduct of any or all portions of the testing process and to conduct, and to require the Contractor, using the Contractor's equipment and labor, a random re-test.
 - 4. Document all test results and corrective procedures and submit to the Consultant within ten (10) working days of test completion.

3.6 TRAINING

- A. User Training.
 - 1. Provide up to 8 hours of system and software training in at least two separate sessions for 2 to 5 members of the owner's staff. Provide an additional follow-up training session of up to two hours within 6 week of final acceptance.
 - 2. All training shall be on the Owner's premises using the installed system.
 - 3. Provide telephone technical support to the Owner for a minimum of one year after acceptance of the system.
- B. Engage a factory-authorized service representative to train Owner's maintenance personnel to adjust, operate, and maintain security access system.
 - 1. Develop separate training modules for the following:
 - a. Computer system administration personnel to manage and repair the system and databases and to update and maintain software.
 - b. Operators who prepare and input credentials to man the control station and workstations and to enroll personnel.
 - c. Security personnel.
 - d. Hardware maintenance personnel.
 - e. Corporate management.

3.7 SYSTEM SOFTWARE

- A. Develop, install, configure and test software and databases for the complete and proper operation of systems involved. Assign software license to Owner.

3.8 ACCEPTANCE

- A. Once the testing has been completed, as-built and testing documentation delivered to the Owner and the Owner is satisfied that all work is in accordance with the contract documents, the Owner will notify the contractor in writing of the acceptance of the work performed. The date of this acceptance shall constitute the commencement of the warranty period.

3.9 STARTUP SERVICE

- A. Engage a factory-authorized service representative to supervise and assist with startup service. Complete installation and startup checks according to approved procedures that were developed in "Preparation" Article and with manufacturer's written instructions.
 - 1. Prepare and issue access cards and finalized database for Owner's operators, management, and security personnel.
 - 2. Train security personnel.

END OF SECTION

SECTION 28 31 11

FIRE ALARM EXTENSION

PART 1 - GENERAL

1.1. RELATED SECTIONS

- A. This Section covers the extension of an existing fire detection and alarm system.
- B. Refer to SECTION 260000 for other general requirements.
- C. Section 01 81 13 "Sustainable Design Requirements – LEED v4 for Building Design & Construction – New Construction" for sustainable design requirements and detailed sustainable design submittal requirements.
- D. Section 01 74 19 "Construction and Demolition Waste Management and Disposal" for disposal of construction, demolition and packaging waste disposal requirements.

1.2. SCOPE

- A. Provide labor, materials, equipment, services and transportation necessary for complete and operational fire alarm systems as indicated on Contract Drawings and specified herein.
- B. The present building is equipped with Honeywell voice evacuation fire alarm system. The fire alarm system shall be a Class A wiring extension of this system, integrated to provide a complete system. Extension includes transition to a high-rise selective voice evacuation system.
- C. Modifications include the addition of a new Honeywell XLS networked control panel intended to be the fire command center head-end with all firefighter controls and annunciation. New panel shall be networked to the existing system and include new paging zones, including new stair zones and additional firefighter two way communication phones and associated controls. The existing ground floor panel shall eventually be removed when all notification, annunciation and initiation circuits are cut over to the new fire command panel.
- D. Provide a modification to the existing closed circuit, electrically supervised automatic and manual, local energy, auxiliary fire alarm system, according to the Drawings and Specification. The system shall be wired, connected, tested and left in first-class operating condition. The equipment and completed installation shall be in compliance with local and National Codes, authorities having jurisdiction and in accordance with applicable sections of the latest edition of NFPA 72 for auxiliary fire alarm systems. All equipment shall be NRTL listed for use with the existing system and shall meet with the approval of the State Fire Marshal and local authorities.
- E. All new equipment shall be provided by the original manufacturer for complete compatibility with the existing system and to provide one manufacturer with total responsibility for the entire system operation, warranty and maintenance. No other manufacturer will be considered acceptable.
- F. All final connections, testing and adjusting of the system shall be done under the

direct supervision of the system supplier and the Building Owner's Testing and Service company. After completion of the installation, a trained technician employed by the system supplier shall demonstrate the system to be satisfaction of the Owner's Representative and local authorities and shall make all additional adjustments to the system operation as required by the Owner's Representative or local authority as a result of this demonstration. Pay cost for all services to be provided by Owner's Testing and Service company.

- G. Verify the existing system operation prior to starting work. Be responsible for proper system operation at the completion of work. Consult with manufacturer and the Service Company and carry the costs for a complete and operational system.
- H. Testing company shall be certified by UL and approved by the local fire department.
- I. Existing System Operation:
 - 1. It is imperative that a completely operable and operating fire detection and fire alarm system be maintained in all areas of the building where such protection is presently provided.
- J. Temporary and short interval interruptions of the ability of a single existing system zone in any area of the building to operate may be tolerated with the express written permission of the Building Owner and local Authority. This permission will only be considered if a written request for such an interruption is made before the actual need therefore. It shall be understood that the time at which an interrupt may begin and the length of its duration shall be at the discretion of the Owner, and that this Section shall provide and bear all costs for a fire-watch. The specifics of the fire-watch shall be as required by the Building Owner and local Authority.
- K. The entire system of audible and visual alarm signal units and their operating equipment shall be maintained in full operable and operating condition until such time as the complete New Fire Detection, Communication and Evacuation System is installed and is operable.
- L. Sustainable Building Requirements:
 - 1. The Owner requires the Contractor to implement practices and procedures to meet the project's environmental performance goals, which include achieving LEED version 4 Certified level Certification. Specific project goals that may impact this area of work include: use of recycled-content materials; use of locally-manufactured materials; use of low-emitting materials; construction waste recycling; and the implementation of a construction indoor air quality management plan. The Contractor shall ensure that the requirements related to these goals, as defined in the Articles below, are implemented to the fullest extent. Substitutions, or other changes to the work proposed by the Contractor or their Subcontractors, shall not be allowed if such changes compromise the aforementioned environmental goals and LEED certification.

1.3. SUBMITTALS

- A. Submit for review shop drawings on following:
 - 1. Automatic detectors
 - 2. Audio and visual units
 - 3. Fire alarm pull stations
 - 4. Control panel additions/modifications including measurement of the load on existing circuits to be connected to and calculations indicating adequacy of these circuits or the new circuits to be added to support the devices indicated

- or specified.
5. Added batteries and associated calculations.
 6. A detailed list of each new piece of equipment with model numbers for each component
 7. Manufacturer's Produce Data Specification Sheets on each item of equipment
 8. Confirmation on manufacturer's letterhead that the manufacturer's representative has reviewed the existing system and is providing all required components for a complete and operational system as indicated herein and on the Drawings, will provide jobsite supervision during the installation of the system, perform the final testing of the system and conjunction with the Owner's testing and service company and instruct the operating personnel on the operation of the system.
 9. Detailed one line schematic wiring diagrams of the system and its interconnecting wiring. Typical wiring diagram will not be accepted. All data submitted shall be complete for all equipment and shall apply only to this specific project. All extraneous material shall be deleted.
 10. Shop drawings that are submitted for review without all of this information will not be considered and will be rejected.

1.4. RECORD DRAWINGS

- A. Prior to final inspection and instruction period, deliver following items in duplicate to Architect.
 1. Certificate by manufacturer of fire alarm system, which states that system has been properly installed, adjusted and tested.
 2. Complete operating and maintenance manuals including wiring diagrams, technical data sheets and information for ordering replacement parts.
 3. "As built" riser diagrams which indicate each piece of equipment and interconnecting wiring; and complete diagrams of internal wiring for each piece of equipment, including "as built" revisions. Diagrams shall identify wiring terminals and wiring sequences to facilitate installation, operation and maintenance.

PART 2 - PRODUCTS

2.1. FIRE ALARM SYSTEM - GENERAL

- A. Provide an extension of the existing automatic and manual, closed circuit, double supervised fire alarm system with battery standby. System shall meet approval of local fire department.
- B. Activation of any fire alarm initiating device shall cause the system to initiate the sequence established by the current building system.
- C. When smoke detector goes into alarm condition, its integral alarm lamp and remote alarm lamp, if any, shall energize until detector has been reset.
- D. System shall supervise disarrangement conditions. Provide electrical supervision under normal and standby power conditions.
 1. Upon detecting disarrangement, system "trouble" LED shall flash and integral audible trouble signal shall sound until trouble signal is manually acknowledged.
 2. Upon acknowledgment, audible device shall silence and "trouble" LEDs shall

- stop flashing but remain energized (steady).
3. When disarrangement has been restored to normal and system has been manually reset, visual indicators shall return to unlit condition.
 4. Disarrangement indicators shall automatically de-energize during system alarm conditions and shall reappear only after alarm condition has been reset.
 5. Provide separate LED to distinguish system "ground" conditions.
 6. Alarm initiation circuits shall be supervised for open and ground conditions. Provide separate "trouble" LED for each circuit.
 7. Audible alarm circuits shall be supervised for open, ground and short conditions. Provide separate "trouble" LED for each circuit.
 8. Green LED shall be energized to indicate normal power condition for 120 VAC primary source. Upon sensing disarrangement in power source, "normal power trouble" LED shall energize and alarm system shall transfer to standby power source. When normal power has been restored, alarm system shall transfer to normal power source.
 9. Provide LED to indicate disarrangement of battery voltage under low voltage and no voltage conditions. Upon sensing battery voltage below preset limit, automatic charger shall supply battery at higher rate and "High Rate" LED shall indicate system disarrangement. Charger failure shall be indicated with separate LED.
 10. Manual bypass of initiation zone, signal circuit, remote alarm transmission circuit, or automatic alarm function shall place system in disarrangement and shall activate circuit and system "trouble" LEDs.

2.2. FIRE ALARM CONTROLS

- A. Provide additional electrically supervised, zone alarm circuit modules to monitor for alarm (shorts), trouble (opens), and ground faults.
- B. Provide additional signal modules to provide supervised circuits for alarm horns. Each signal module shall have individual circuit test and disconnect switches and module disarrangement LED, and shall provide open and short line supervision.
- C. Provide additional power supply modules, with "Normal Power" and "Battery Transfer" LEDs, to provide and supervise operating power to alarm system. Module shall include voltage monitor which automatically transfers system to standby power upon sensing excessive high or low voltage input.
- D. Provide additional battery charger modules as required including trickle rate adjusting control, meter to monitor trickle current and battery voltage, "Charger Failure" monitor and LED indicator and "Charger High Rate" alarm LED.
 1. Provide fully automatic, dual rate charger to keep standby power source at proper charge. Charger shall normally provide "trickle" charge; when needed, charger shall charge at higher rates.
 2. Power to alarm system shall be maintained for over-voltage, under-voltage and power failure conditions.

2.3. BATTERIES

- A. Provide additional batteries of sufficient capacity to operate and supervise entire alarm system for 24 hours with commercial power disconnected and to sound alarm for fifteen minutes at end of this period.
- B. Provide new battery cabinets as required.

2.4. FIRE ALARM STATIONS

- A. Provide fire alarm stations, to match existing system.

2.5. HEAT AND SMOKE DETECTORS

- A. Provide 135°F or 200°F fixed temperature thermodetector. Mount thermodetectors on standard 4" octagonal box.
- B. Provide combination solid state photo-electronic, area smoke detectors which operate on light scattering, photodiode principle with integral 135°F heat detectors. NO radioactive material shall be used.
 - 1. To minimize nuisance alarms, detectors shall be designed to ignore invisible airborne particles and smoke densities below factory setpoint.
 - 2. Detectors shall be factory set to detect smoke at nominal 1.5% light obscuration per foot.
- C. Provide duct smoke detectors, complete with auxiliary contacts for temperature control fan shutdown, sampling tubes and remote test station.
- D. Detectors shall be NRTL listed and FM approved for duct, heat or smoke detectors, as appropriate.

2.6. VISUAL AND AUDIBLE UNITS

- A. Provide light strobe unit with Xenon flash. Candela rating of unit shall be as indicated on the Drawings and under EXECUTION.
- B. Provide flush-mounted combination audible and visual units with Xenon flash. Provide synchronized light units. Audible units shall have adjustable sound levels. Provide nominal sound level of 90 dB at ten feet. Refer to EXECUTION Part 3 for sound level requirements.
 - 1. Lens shall be visible from both directions and shall have "FIRE" imprinted in red on white lens background.
 - 2. Units shall be housed in rugged die cast enclosure, with molded impact-resistant exterior and tamperproof lens. Unit shall be arranged for installation of lens either above or below horn.

PART 3 - EXECUTION

3.1. INSTALLATION

- A. Installation shall be in accordance with the Electric Code, NFPA 72, local and state codes, as indicated on the Drawings, and as recommended by the system manufacturer.
- B. All conduit, junction boxes, conduit supports and hangers shall be concealed in finished areas and may be exposed in unfinished areas. Smoke detectors shall not be installed prior to the system programming and test period. If construction is ongoing during this period, measures shall be taken to protect smoke detectors from contamination and physical damage.
- C. All fire detection and alarm system devices, control panels and remote annunciators shall be flush mounted when located in finished areas and may be surface mounted when located in unfinished areas.

- D. Provide in accordance with manufacturer's instructions, all wiring, conduit and outlet boxes required for the installation of the complete system as specified and described herein and as indicated on the Drawings. Ensure that any new work or wiring performed within the new area shall in no way impair or adversely affect the performance of the existing building's fire alarm system in areas adjacent to the new area.
 - E. Fire Department Requirements:
 - 1. Coordinate with and provide all items required by the local Fire Department. Pay all costs.
 - 2. Confirm operations and testing with local fire department and pay all back charges.
 - F. Provide complete wiring and conduit between all equipment. All devices shall be mounted upon and terminations made in NRTL listed boxes. Wiring splices and transposing or changing of colors will not be permitted.
 - G. Use 14 AWG minimum size solid conductors for fire alarm detection and signal circuit conductors unless otherwise required by the manufacturer. Use shielded wiring for initiating circuits. Provide separate conduits or cables for trunks (communication between panels), signaling and initiating circuits.
 - H. Terminate conductors using ring type compression connectors on labeled and numbered terminal blocks. Do not splice conductors. Label conductors at all terminations with terminal number and system number.
 - I. Wiring for the fire alarm system shall be in conduit except where it must be fished in, if approved in writing by the local authority, may be Type MC cable with a red identifying stripe. Install wiring concealed in finished area, wiring may be exposed in unfinished areas. Provide surface raceway as directed by Architect where installing concealed is not practicable.
 - J. Junction boxes, pull boxes, terminal boxes, outlet boxes and covers in the fire alarm raceway system shall be painted red.
 - K. Fire alarm junction boxes and terminal cabinets shall have a capacity forty percent greater than that required for the wiring and terminal blocks. Paint box or cabinet fire alarm red and identify with white lettering on the cover "FIRE ALARM SYSTEM". Indicate locations of terminal boxes and cabinets on Record Drawings.
 - L. Fire alarm control system and equipment shall be connected to separate dedicated branch circuits, sized as required for proper service. Circuits shall be labeled "FIRE ALARM". Provide circuit breaker lock on devices for each circuit breaker.
 - M. Make conduit and wiring connections to door release devices, sprinkler flow switches, sprinkler valve tamper switches, fire suppression system control panels, duct smoke detectors, AHUs, related systems and as indicated on the Drawings.
 - N. Mount end of line devices in control panel or in terminal cabinets. Properly label and mount securely. Indicate on Record Drawings.
 - O. Automatic Detectors Installation: Conform to NFPA 72.
 - P. Provide nameplates on remote status lights and test stations.
 - Q. Install manual stations with operating handle 4 feet (1.2 M) above floor.
- 3.2. AUDIBLE/VISUAL DEVICES

- A. Audible devices shall be set for the following minimum dB levels:
 - 1. General Areas - 90 dB at ten feet.
 - 2. Small rooms (e.g. toilets, etc.) - 85 dB at ten feet.
 - 3. Mechanical Rooms, Equipment Spaces - 95 dB at ten feet.
 - 4. Adjust and set as required by the Fire Department.
 - B. Visual devices shall have minimum effective intensity ratings as indicated on the drawings or if not indicated provide as follows:
 - 1. Corridors - 15 candela.
 - 2. General - 75 candela.
 - 3. Assembly areas - 110 candela.
 - 4. Rooms over 100 feet in both directions - 110 candela.
 - C. Install audible and visual signal devices 6 feet 8 inches (80 inches) above the floor or as required to meet the accessibility code requirements.
 - D. Locate remote indicating pilot lights outside of room in normal view above door to isolated space, on ceiling, or on wall at six feet (2m) above finished floor in locations approved by the Architect. Provide nameplates. Locate to be centered and symmetrical with surrounding architecture.
 - E. Locate remote alarm, status LED's in a location approved by the Architect on the wall at six feet above finished floor, or on the ceiling below the unit or in mechanical spaces near the door. Provide nameplates. Locate to be centered and symmetrical with surrounding architecture.
- 3.3. EXTRA MATERIALS
- A. Provide extra materials as indicated below:
 - 1. Three of each automatic smoke and heat detector (without base).
- 3.4. MANUFACTURER'S FIELD SERVICES
- A. Provide manufacturer certified and trained technicians and representatives for demonstration testing, supervision and assistance in the installation of the fire alarm system. Connections and terminations shall be made under the direct supervision of the fire alarm manufacturer. Equipment manufacturer shall be responsible for demonstration tests, programming, adjustment and calibration of the equipment.
- 3.5. ACCEPTANCE TESTING
- A. Pre-test the entire system and all functions to verify complete operation. After correct operation is verified, notify the Fire Department, local authorities, Owner and the Architect that system is complete and ready for acceptance testing. Provide testing at a time mutually agreeable to all parties. Provide a minimum one week notice.
 - B. Testing shall be as required by the Fire Department, Local Authorities, the Owner and the Architect. At a minimum, operate every building fire alarm device to ensure proper operation, correct annunciation at each remote annunciator and control panel. One-half of all tests shall be performed on standby power. Where applying heat would destroy any detector, they may be manually operated.
 - C. Tests shall be performed in the presence of the Project Foreman, the Owner's rep-

representative, fire authority of the fire jurisdiction and the representative of the fire alarm system manufacturer.

- D. Provide the service of a competent, factory-trained engineer or technician authorized by the manufacturer of the fire alarm equipment to technically supervise and participate during all of the adjustments and tests for the system. All testing shall be in accordance with NFPA 72. Provide type written reports of results and system information as required by forms in NFPA 72.
- E. The entire system shall be marked per device circuit to indicate function and operation from manufacturer's point-to-point wiring diagrams. Drawings shall be signed by the Installer, Manufacturer and UL certified Testing Company and the Fire Department's Representative.
- F. Upon completion of testing, co-signed drawings and reports shall be forwarded to the Architect for record purposes for final acceptance. Testing and reports shall comply with NFPA 72 standard requirements.
- G. Pay all costs for certification, testing and fire department approvals.
- H. Leave the fire alarm system in proper working condition.
- I. Provide copies of testing reports and UL certification in the O&M manuals.

3.6. FINAL INSPECTION

- A. At the final inspection a factory trained representative of the manufacturer of the major equipment shall demonstrate that the systems function properly in every respect.

3.7. INSTRUCTION

- A. Provide instruction as required for operating the system. Hands-on demonstrations of the operation of all system components and the entire system including program changes and functions shall be provided.
- B. Provide a type written "Sequence of Operation" to the owner.

END OF SECTION

SECTION 28 31 11.11

BI-DIRECTIONAL ANTENNA SYSTEM

PART 1 - GENERAL

1.1. REFERENCES

- A. This Section covers a firefighter's two way communications system referred to in this section as a Bi-Directional Antenna System (BDA).
- B. Refer to SECTION 260000 for other general requirements.
- C. Section 01 81 13 "Sustainable Design Requirements – LEED v4 for Building Design & Construction – New Construction" for sustainable design requirements and detailed sustainable design submittal requirements.
- D. Section 01 74 19 "Construction and Demolition Waste Management and Disposal" for disposal of construction, demolition and packaging waste disposal requirements.

1.2. SUMMARY

- A. Sustainable Building Requirements:
 - 1. The Owner requires the Contractor to implement practices and procedures to meet the project's environmental performance goals, which include achieving LEED version 4 **Certified** level Certification. Specific project goals that may impact this area of work include: use of recycled-content materials; use of locally-manufactured materials; use of low-emitting materials; construction waste recycling; and the implementation of a construction indoor air quality management plan. The Contractor shall ensure that the requirements related to these goals, as defined in the Articles below, are implemented to the fullest extent. Substitutions, or other changes to the work proposed by the Contractor or their Subcontractors, shall not be allowed if such changes compromise the aforementioned environmental goals and LEED certification

1.3. SCOPE

- A. Provide labor, materials, equipment, services and transportation necessary for complete and operational BDA system as indicated on Contract Drawings and specified herein.
- B. All final connections, testing and adjusting of the system shall be done under the direct supervision of the system supplier and the Building Owner's Testing and Service company. After completion of the installation, a trained technician employed by the system supplier shall demonstrate the system to be satisfaction of the Owner's Representative and local authorities and shall make all additional adjustments to the system operation as required by the Owner's Representative or local authority as a result of this demonstration. Pay cost for all services to be provided by Owner's Testing and Service company.
- C. Installation and Testing company shall be certified by UL and approved by the local fire department.

1.4. SUBMITTALS

- A. Submit for review shop drawings on following:
 - 1. Bi-directional radio amplifier
 - 2. Radiating coaxial cable (if required)
 - 3. Coaxial cable
 - 4. Antennas (if required)
 - 5. Terminators
 - 6. T-taps (if required)
 - 7. Other components and interconnecting circuitry as required
 - 8. UPS Power systems
 - 9. Detailed one line schematic wiring diagrams of the system and its interconnecting wiring. Typical wiring diagram will not be accepted. All data submitted shall be complete for all equipment and shall apply only to this specific project.
 - 10. Shop drawings that are submitted for review without all of this information will not be considered and will be rejected.

PART 2 - PRODUCTS

- A. Provide a Bi-Directional Antenna System meeting all the requirements of the Local Fire Department.
- B. The Local Fire Department radio test shall check the signal reception at several locations on the floor area. Signal strength shall be as required for clear reception throughout the building utilizing the type of hand held radio unit that is used by the Local Fire Department. Quantity of test locations shall be determined and conducted by the local fire department representative. The owner's project manager shall be present during said test. A minimum of test point locations shall be determined by the following equation: $\text{Number of equally spaced test points} = [(\text{floor square footage}) / (25000)] * 2$ specific test locations may need to be considered in areas containing special wall constructions or large quantities of electromechanical building system equipment.
- C. Required Signal Levels
 - 1. Signal strength shall be as required for clear reception throughout the building utilizing hand held radio units of the type(s), which are used by the Local Fire Department.
 - 2. A minimum signal strength of -95 dBm (DAQ4) shall be available on over 95% of the floor area requiring coverage when transmitted from the fire department.
 - 3. A minimum signal strength of -95 dBm (DAQ4) shall be received at the fire department system from over 95% of the floor area requiring coverage.
- D. Required Broadcasting Frequencies
 - 1. Typical downlink frequency range for Local Fire Department shall be as required to be compatible with Local Fire Department equipment.

Note: The building owner will be responsible for keeping the operational frequencies of the BDA compatible with the Local Fire Department radio system.
- E. The bi-directional antenna type system shall consist of the following components:
 - 1. Bi-directional radio amplifier
 - 2. Radiating coaxial cable (if required)
 - 3. Coaxial cable

4. Antennas (if required)
 5. Terminators
 6. T-taps (if required)
 7. Other components and interconnecting circuitry as required
 8. UPS Power systems
- F. It is the intent of these specifications that where a BDA system is required, a complete fully functioning system will be designed, approved and tested before an Occupancy Permit is issued.
- G. The selected vendor/electrical contractor will complete a Fire Alarm Permit Application acquired from the Fire Prevention Division stating a "BDA" installation. Plan Review: Provide one line, schematic and detail drawings of the proposed system architecture. Indicate proposed locations for system components. Provide specifications for procurement and installation of a complete system, including operating frequencies, for review by the Local Fire Department, and all other agencies and authorities having jurisdiction.
- H. Testing and Commissioning: Coordinate the completion date of the Fire Department radio signal repeater system to allow a Certificate of Occupancy to be obtained in a timely manner, in accordance with a schedule established by the owner's project manager. The entire system shall meet with the approval of the Local Fire Department, and all other agencies and authorities having jurisdiction, before a Certificate of Occupancy will be issued.
- I. Design Data: Include signal calculations.
- J. Test Reports: Indicate measured signal levels pre-installation and post installation.
- K. Filings: The design engineer shall provide all necessary documents required by the contractor for submitting to the Local Fire Department, Local ISD, and any other agencies having jurisdiction. Necessary documents shall include but not be limited to the required quantities of floor plans, system narrative, system specifications, wiring diagrams, shop drawings and any aforementioned documents requiring the engineer's signature.
- L. Permits: Permits necessary for installation of the work shall be obtained prior to beginning work. All filing fees, permit costs, and inspection fees shall be included as part of the required work.
- M. The system shall be completed with all components and wiring required for compliance with all applicable codes and regulations, and for its operation as described hereinafter. No exclusion from or limitation in the symbolism used on the drawings or the language used in these specifications shall be interpreted as a reason for omitting any appurtenances or accessories required to enable the system to perform the specified functions.
- N. Upon completion of the installation, the work shall include making all arrangements with the owner's project manager and providing any assistance necessary for inspection and test as required for approval by the Local Fire Department. Modifications, adjustments and/or corrective work necessary to obtain approval along with subsequent inspection and test resulting from the issuance of a "Notice of Defect" shall precede any consideration of formal acceptance by the building owner. In conjunction with the above, training as deemed necessary to instruct authorized building personnel in the proper operation of the system shall also form a part of the required work.

- O. The central equipment shall be supplied with an emergency power unit including batteries and battery charging equipment that maintains this equipment, and all outlying equipment that requires power operation, without any change in status for a minimum period of twenty-four (24) hours. Optionally, emergency power may be supplied by an emergency generator. The emergency power units(s) shall be sized to meet the following minimum requirements: operating in normal (supervisory) mode, twenty-four (24) hours, followed by twelve (12) hours of emergency operation. Batteries shall be of the sealed maintenance free type.
- P. System design shall be such that neither the failure of the normal power source, the transfer to an emergency source, nor the transfer back to the normal source shall cause a change in system status.
- Q. Battery low voltage alarm contacts shall activate "trouble" indication at the Fire Alarm Annunciator to read "BDA Back up Power Trouble."
- R. Loss of A.C. input power or failure of the UPS power system shall provide an Indication at the Fire Alarm Annunciator to read "BDA Power Failure."
- S. Amplifier failure shall provide an indication at the Fire Alarm Annunciator to read "BDA System Failure."
- T. Alarms from the amplifier and power systems shall be of a contact closure type with demarcation on a punch-block. Normally open and normally closed points shall be clearly identified so appropriate status can be visualized at the central equipment. The contractor shall be responsible for wiring the alarms to the punch-block but not to the fire control central equipment, which will be done by others.
- U. Secured Space
 - 1. The bi-directional radio amplifiers shall not be located in electric closets. They shall be located in a suitable non-finished space as approved by the engineer and/or where specifically shown on the drawings. The entrance to the secured space shall clearly identify the space as having the "Local Fire Department" radio signal repeater equipment, by the use of an attached engraved name-plate
- V. Unsecured Space
 - 1. The bi-directional amplifiers shall be provided with NEMA 1 enclosures, hinged lockable doors, electric supervision against unauthorized access and the removal of any components, and shall each have an attached engraved name-plate identifying the unit.
- W. The bi-directional amplifier shall be supplied with cavity style filtering in order to minimize unwanted frequencies from entering the amplifier. Cavities shall be tuned to the frequencies from Section 1 Item D. above. Cavity filters will be housed to allow access by technicians, but will be protected from tampering, or accidental damage.
- X. Units as approved by Local Fire Department shall manufacture the bidirectional radio amplifier.
- Y. The bi-directional amplifier shall contain automatic limiting control circuitry to avoid producing overdriven outputs from the amplifier.
- Z. The firefighter's communication bi-directional radio amplifier system shall be by a competent installer with a minimum of five years service in in-building RF solutions.
- AA. Components indicated on the drawings shall be located where shown. Components

which are required for proper operation, but which are not indicated on the drawings shall be located in mechanical rooms, at accessible locations within suspended ceilings, or at locations for which express permission of the owner's project manager has been obtained.

BB. Note the following circuitry requirements:

1. Conduit intended for use with the firefighter's communication bidirectional radio amplifier system shall be steel electrical metallic tubing (EMT), except as follows:
 - a. It shall be galvanized steel intermediate conduit where mounted within 8'-0" of the floor in mechanical spaces or otherwise exposed to mechanical damage, or where intended for embedment in concrete.
 - b. It shall be galvanized steel intermediate conduit if local authorities prohibit use of EMT.
 - c. It shall be rigid galvanized steel conduit for the power supply to the central equipment and to all outlying equipment cabinets requiring a 120-volt or 120/208-volt supply.
2. Where wires and cables are permitted to be run without conduit, they shall be independently supported from the building structure or ceiling suspension systems at intervals not exceeding four feet on center, utilizing cable supports specifically approved for the purpose. Wires and cables shall not rest on or depend on support from suspended ceiling media (tiles, lath, plaster, as well as splines, runners or bars in the plane of the ceiling), nor shall they be supported from pipes, ducts or conduits. Bundling and/or supporting ties shall be of a type suitable for use in a ceiling air handling plenum regardless of whether or not installed in a plenum.
3. Cables shall be tagged or labeled at each termination point and in each intermediate junction box, pull box or cabinet through which they pass, as well as intervals not exceeding 50 feet on centers where cables are run without conduit.
4. Comply with applicable building and electrical code requirements for locating and routing circuitry, for installing circuitry, and for fire stopping.
5. The covers of all dedicated junction, pull boxes shall be painted red and labeled "Fire Dept. Radio System". Junction and pull boxes will not be shared with other systems.
6. Cables other than radiating coaxial cables shall be run in conduit where indicated by the Engineer. Where not indicated, cable shall be installed per manufacturer's recommendation. Conduit shall be electrical metallic tubing or threaded conduit subject to the restrictions specified elsewhere for light and power circuitry.
7. Radiating coaxial cables shall be run without conduit. Where installed in a plenum type ceiling cable insulation shall be of a fire resistant low-smoke producing type, with a minimum rating of CATVR. This classification shall be clearly marked on the outer surface of the cable at regular intervals.

CC. Submit certification that system is compatible with Local Fire Department radio systems prior to installation.

DD. Verify proper operation of system by means of field tests in accordance with Local Fire Department requirements, and include all adjustments and modifications to the system required for proper operation. Coverage of each floor of the building to a

minimum of 95% is required for acceptance. Testing shall be performed and signed by a qualified radio technician with a minimum of 10 years RF experience whose qualifications are acceptable to Local Fire Department.

1. No activation or power up of any RF equipment is permitted without first obtaining permission of the Local Fire Department. This includes any testing or calibration.

PART 3 - EXECUTION

3.1. INSTALLATION

- A. Installation shall be in accordance with the Electric Code, NFPA 72, local and state codes, as indicated on the Drawings, and as recommended by the system manufacturer.
- B. All conduit, junction boxes, conduit supports and hangers shall be concealed in finished areas and may be exposed in unfinished areas.
- C. Provide in accordance with manufacturer's instructions, all wiring, conduit and outlet boxes required for the installation of the complete system as specified and described herein and as indicated on the Drawings.
- D. Fire Department Requirements:
 1. Coordinate with and provide all items required by the local Fire Department. Pay all costs.
 2. Confirm operations and testing with local fire department and pay all back charges.
- E. Provide complete wiring and conduit between all equipment. All devices shall be mounted upon and terminations made in listed boxes.
- F. Use 14 AWG minimum size solid conductors for circuit conductors unless otherwise required by the manufacturer.
- G. Terminate conductors using ring type compression connectors on labeled and numbered terminal blocks. Do not splice conductors. Label conductors at all terminations with terminal number and system number.
- H. Junction boxes, pull boxes, terminal boxes, outlet boxes and covers in the fire alarm raceway system shall be painted red.

3.2. EXTRA MATERIALS

- A. Provide extra materials as indicated below:
 1. Three of each automatic smoke and heat detector (without base).

3.3. MANUFACTURER'S FIELD SERVICES

- A. Provide manufacturer certified and trained technicians and representatives for demonstration testing, supervision and assistance in the installation of the fire alarm system. Connections and terminations shall be made under the direct supervision of the fire alarm manufacturer. Equipment manufacturer shall be responsible for demonstration tests, programming, adjustment and calibration of the equipment.

3.4. ACCEPTANCE TESTING

- A. Pre-test the entire system and all functions to verify complete operation. After correct operation is verified, notify the Fire Department, local authorities, Owner and the Architect that system is complete and ready for acceptance testing. Provide testing at a time mutually agreeable to all parties. Provide a minimum one week notice.
 - B. Testing shall be as required by the Fire Department, Local Authorities, the Owner and the Architect. At a minimum, operate every building fire alarm device to ensure proper operation, correct annunciation at each remote annunciator and control panel. One-half of all tests shall be performed on standby power. Where applying heat would destroy any detector, they may be manually operated.
 - C. Tests shall be performed in the presence of the Project Foreman, the Owner's representative, fire authority of the fire jurisdiction and the representative of the fire alarm system manufacturer.
 - D. Provide the service of a competent, factory-trained engineer or technician authorized by the manufacturer of the fire alarm equipment to technically supervise and participate during all of the adjustments and tests for the system. All testing shall be in accordance with NFPA 72. Provide type written reports of results and system information as required by forms in NFPA 72.
 - E. The entire system shall be marked per device circuit to indicate function and operation from manufacturer's point-to-point wiring diagrams. Drawings shall be signed by the Installer, Manufacturer and UL certified Testing Company and the Fire Department's Representative.
 - F. Upon completion of testing, co-signed drawings and reports shall be forwarded to the Architect for record purposes for final acceptance. Testing and reports shall comply with NFPA 72 standard requirements.
 - G. Pay all costs for certification, testing and fire department approvals.
 - H. Leave the fire alarm system in proper working condition.
 - I. Provide copies of testing reports and UL certification in the O&M manuals.
- 3.5. FINAL INSPECTION
- A. At the final inspection a factory trained representative of the manufacturer of the major equipment shall demonstrate that the systems function properly in every respect.
- 3.6. INSTRUCTION
- A. Provide instruction as required for operating the system. Hands-on demonstrations of the operation of all system components and the entire system including program changes and functions shall be provided.
 - B. Provide a type written "Sequence of Operation" to the owner.

END OF SECTION

This page is intentionally left blank.

SECTION 284111

AREA OF RESCUE ASSISTANCE INTERCOM SYSTEM

PART 1 - GENERAL

1.1 RELATED DOCUMENTS

- A. Drawings and general provisions of the Contract, including General and Supplementary Conditions and Division 01 Specification Sections, apply to this Section.
- B. Section 01 81 13 "Sustainable Design Requirements – LEED v4 for Building Design & Construction – New Construction" for sustainable design requirements and detailed sustainable design submittal requirements.
- C. Section 01 74 19 "Construction and Demolition Waste Management and Disposal" for disposal of construction, demolition and packaging waste disposal requirements.

1.2 SUMMARY

- A. The specification describes an addressable microprocessor based area of rescue assistance intercom system. The system shall be an analog addressable, low voltage and modular, with digital communication techniques, in full compliance with all applicable codes and standards.
- B. Install, program, test, and deliver to the Owner in fully operational condition including all required hardware, software, raceways and interconnecting wiring as required. The system shall consist of, but not be limited to, the following:
 - 1. Main Control Unit with enclosure and battery back-up.
 - 2. Master Console.
 - 3. PBX Telephone Interface
 - 4. Remote Call Station.
- C. Prior to the commencement of work, obtain all permits necessary for installation of the work. All permit costs and inspections fees shall be included as part of the required work. After completion of work, notify all authorities having jurisdiction.
- D. Related sections include the following:
 - 1. Low-Voltage Electrical Power Conductors and Cable.
 - 2. Raceways and Boxes for Electrical Systems.
- E. Coordinate with the Architect for final locations and appearance of devices.
- F. Sustainable Building Requirements:
 - 1. The Owner requires the Contractor to implement practices and procedures to meet the project's environmental performance goals, which include achieving LEED version 4 Certified level Certification. Specific project goals that may

impact this area of work include: use of recycled-content materials; use of locally-manufactured materials; use of low-emitting materials; construction waste recycling; and the implementation of a construction indoor air quality management plan. The Contractor shall ensure that the requirements related to these goals, as defined in the Articles below, are implemented to the fullest extent. Substitutions, or other changes to the work proposed by the Contractor or their Subcontractors, shall not be allowed if such changes compromise the aforementioned environmental goals and LEED certification.

1.3 SUBMITTALS

- A. Prior to the start of work, provide a complete and comprehensive submittal for review. Describe the proposed system and its equipment. Failure to provide a complete submittal shall be grounds for rejection of submission. Submittal shall include, but not be limited to, all of the following material:
 - 1. Battery capacity: Minimum of 125% of the operating requirement.
 - 2. Power requirements for all equipment: Minimum 25% spare capacity.
- B. Shop Drawings:
 - 1. Drawing or catalog page showing actual dimensions of system components.
 - 2. Single line riser diagram showing all equipment, all connections and number and size of all conductors and conduits.
 - 3. Wiring Diagrams: Detail wiring, differentiate between manufacturer-installed and field-installed wiring.
 - 4. Provide samples when so requested by the Architect/Engineer.
- C. Provide the address, telephone number, and contact person(s) of the manufacturer's local service facility for normal and off hour warranty issues.

1.4 QUALITY ASSURANCE

- A. Manufacturer Qualifications: A firm experienced in manufacturing systems similar to those indicated for this Project and with a record of successful in-service performance.
- B. Installer Qualifications: An experienced installer who is an authorized representative of the manufacturer for both installation and maintenance of units required for this Project.
- C. Source Limitations: Obtain area of rescue assistance intercom system components through one source from a single manufacturer.
- D. Comply with applicable building code, local ordinances and regulations, and requirements of authorities having jurisdiction.
- E. Comply with National Electric Code (NEC).
- F. Comply with Massachusetts State Building Code.
- G. Comply with all applicable UL Standards.

- H. Comply with Americans with Disabilities Act (ADA).

1.5 COORDINATION

- A. Coordinate work in this Section with all related trades.

PART 2 - PRODUCTS

2.1 MANUFACTURERS

- A. Manufacturers: Subject to compliance with requirement, provide products b one of the following
 1. Jeron Electronic Systems, Inc.
 2. TekTone Sound and Signaling, Inc.
 3. Alpha Communications.

2.2 FUNCTIONAL DESCRIPTION OF SYSTEM

- A. Basic System Equipment, Circuiting, Addressing and Operating Capabilities
 1. Main Control Unit shall be a Jeron Electronic System, Inc. #4851 with #5288 enclosure. Unit shall support up to 128 remote call stations without modification. Unit shall provide power, voice amplification, signal tones, and multiplex control logic for Master Console and Remote Call Stations. Unit shall have a self-charging battery backup that maintains full system function during line power outages. Non-volatile program memory shall eliminate the need to reprogram the system if power is disconnected. Unit shall continually test system for master and remote call station response. Diagnostic messages shall be reported to master console.
 2. Master Console shall be a Jeron Electronic System, Inc. #4875 with #6269 wall jack for desk mounted console. Console shall provide alphanumeric display of remote station number and location. Console shall be provided with Jeron Electronic System, Inc. #4890 Administration Program Software. Communication for console shall be handset privacy or hands-free. Console shall display multiple calls simultaneously.
 3. PBX Telephone Interface shall be a Jeron Electronic System, Inc. #4862. Interface shall "call forward" to an outside phone via Auto-Dial all calls from remote stations to an unstaffed Master Console. Interface shall have diagnostic indicators to continuously verify operation and a disconnect switch for manual override of the PBX loop connection.
 4. Remote Call Stations shall be a Jeron Electronic System, Inc. #4888. Communications shall be hands-free. Canceling a call from a remote station shall only be possible after acknowledging the call at the Master Console. Remote Stations shall have the ability to interface with a PBX Telephone system to allow calls from Remote Stations to be forwarded to outside telephones. Systems not capable of forwarding calls to outside phones shall not be acceptable. Remote Station shall have a 3" square loud speaker/microphone and a momentary push button switch for placing a call on the system.

B. System Operation

1. Placing calls from remote call stations.
2. Calls shall be placed on the system by momentarily pressing the call button on the Remote Call Station. This action shall cause the following to occur:
 - a. The Remote Call Station's green call placed LED indicator shall light steadily.
 - b. An alert tone shall pulse once at the Remote Call Station to verify call placement on the system.
 - c. The LCD display at the master console shall show the location of the calling station by name and number and an alert tone shall sound.
 - d. The Master Console shall have the capability to display multiple calls simultaneously.
3. Acknowledging/Answering Calls At The Master Console
 - a. The attendant shall acknowledge the call by either pressing the Push-to-Talk button or by lifting the handset.
 - b. When the call is acknowledged at the Master Console, the red Monitor LED on the Remote Call Station shall light steadily and an alert tone shall pulse once.
 - c. The LCD display on the Master Console shall show the name and number of the selected station and "CONNECTED", indicating that voice communication between the Master Console and the Remote Station exists.
 - d. Hands-free, two-way communication may be conducted with the Master Console using the Remote Call Station's built-in loudspeaker.
 - e. After the call is acknowledged, the Remote Call Station indicator shall flash slowly and a pulse tone shall be emitted every two seconds.
4. Canceling Calls
 - a. A call shall only be canceled from the Master Console after it has been acknowledged. After the call has been canceled, the LED indicator extinguishes and communication is terminated.
5. Originating Calls At The Master Console
 - a. The Master Console shall be capable of initiating audio communication with a Remote Call Station at any time by dialing the station number on its keypad. The Master shall also be capable of paging a group of up to 10 Remote Call Stations to broadcast evacuation information.
6. PBX Telephone Interface
 - a. The System shall function as described above regardless of whether the Telephone Interface is, or is not utilized. When the Telephone Interface is employed, calls placed from Remote Stations to an unstaffed Master Console shall be forwarded to outside telephones.
 - b. Each Interface Unit shall connect to a dedicated, analog extension port on the local telephone switch equipment having the capability to provide calling party release. A disconnect pushbutton shall be provided to override the release function of the telephone switch. The Telephone Interface Unit shall be equipped with three diagnostic LEDs to indicate status of the unit.
 - c. The system shall have the ability to perform the following function:

- 1) Have a call from a remote station to an unstaffed Master Console forwarded to an outside phone via auto-dial.
7. Supervision
- a. In the event of circuit trouble with any Remote Call Station, the Master Console shall display the name and number of the station and "TROUBLE."

PART 3 - EXECUTION

3.1 EQUIPMENT INSTALLATION

- A. Locate Master Control Unit as shown on plans. Top of enclosure shall be 6'-0" A.F.F.
- B. Locate PBX telephone Interface next to Master Control Unit as directed by equipment manufacturer.
- C. Locate Master Console recessed in wall. Exact location as directed by Architect/Engineer.
- D. Locate Remote Call Station as shown on plans and/or as directed by Architect/Engineer. Units shall be 44" A.F.F.

3.2 WIRING INSTALLATION

- A. Wiring shall be Category-5 type cable to interconnect system components.
- B. System shall employ multiplexed data transmission requiring no more than six (6) common conductors, with no unique or "home run" conductors.
- C. System wiring shall not require a shielded cable.
- D. All system wiring shall be in conduit. Minimum size conduit shall be 3/4".
- E. All Category-5 wire terminations shall be connectorized according to ANSI Standard T568A.

3.3 FIELD QUALITY CONTROL

- A. Testing
 1. A complete test of the system shall be conducted and shall include, but not necessarily limited to the following:
 - a. All remote call stations transmit a signal to the master console and two-way communication is confirmed.
 - b. All remote call stations call an outside phone and two-way communication is confirmed.

- c. All system components shall be tested and proper operation confirmed.
- d. Manufacturer of system shall submit letter stating system has been tested and is 100% operational.

B. Warranty/Services

1. The contractor shall submit three manufacturer's certified service companies that are in a 50 mile radius of the project. The Owner shall have the ability to utilize any of these firms for service, maintenance, and warranty work if the present company fails to comply with the stated guarantee and warranty conditions.
2. The contractor shall warrantee the complete system for one (1) year from date of final acceptance.

C. Training

1. The owner shall be thoroughly instructed in the use of the Area of Rescue Assistance Intercom System by an authorized distributor of the manufacturer.
2. The system supplier shall provide instruction to the staff by means of a portable demonstration system, which shall be set up in a conference room or auditorium to give the staff hands-on experience without disrupting normal duties.
3. The demonstration system shall include representative components as utilized in the installation. The instructor shall demonstrate the functions of the system with all indicators and tones operational.

END OF SECTION

225 Franklin Street, Suite 1100
Boston, Massachusetts 02110
t +1 (617) 478-0300
f +1 (617) 478-0321
[@perkinswill_bos](https://www.perkinswill.com)

PERKINS
+ WILL

NORTH AMERICA | ASIA | MIDDLE EAST | AFRICA | EUROPE