

**E1 STEEL BRACING DETAIL FOR LOW PARTITIONS W/ UNBRACED ENDS**  
SCALE: 6\"/>

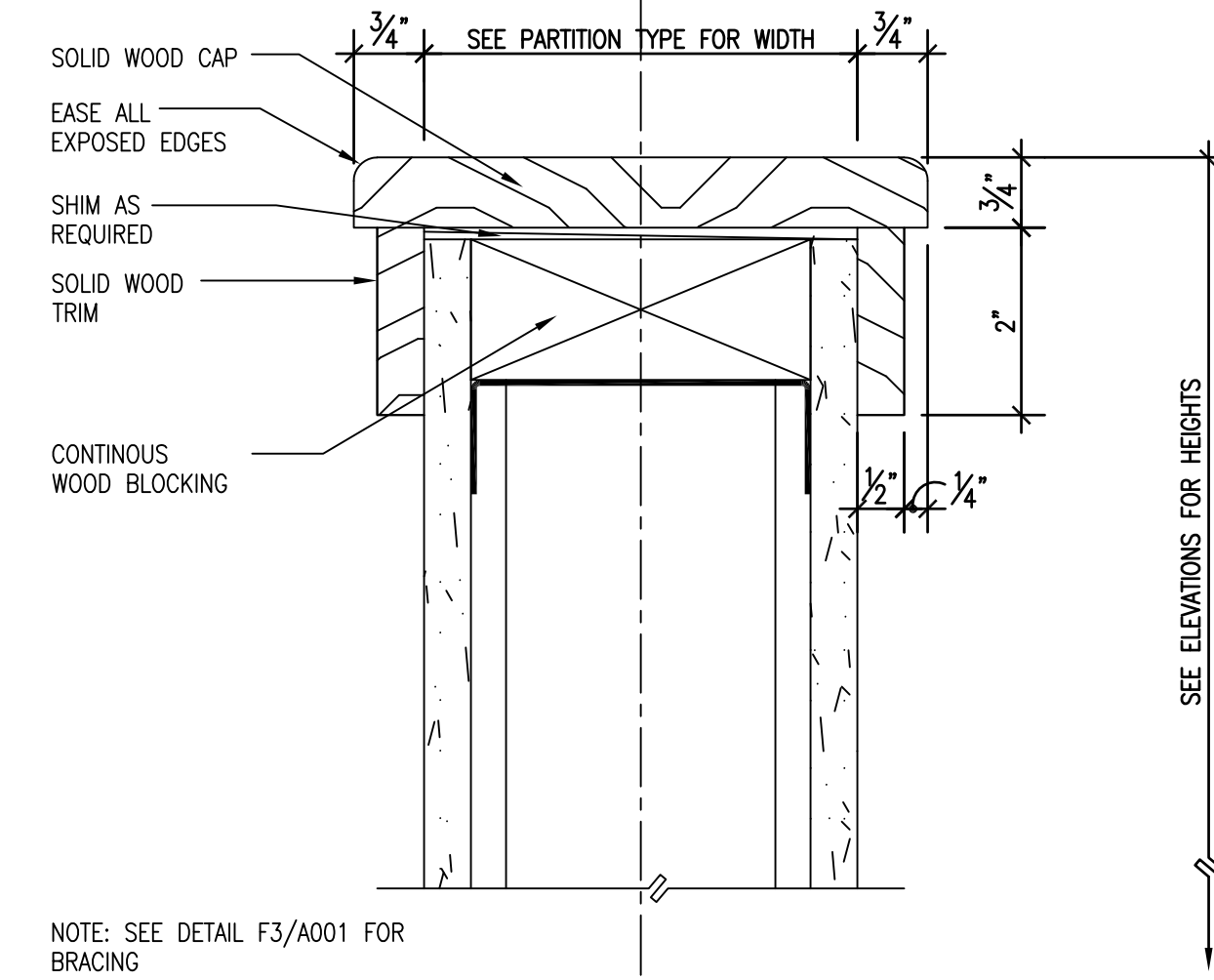

**F1 LOW PARTITION WOOD CAP DETAIL**  
SCALE: 6\"/>

NOTE: AT GROUND AND FIFTH FLOORS, ALL INTERIOR PARTITIONS SHALL BE CONSTRUCTED WITH COLD FORMED METAL FRAMING

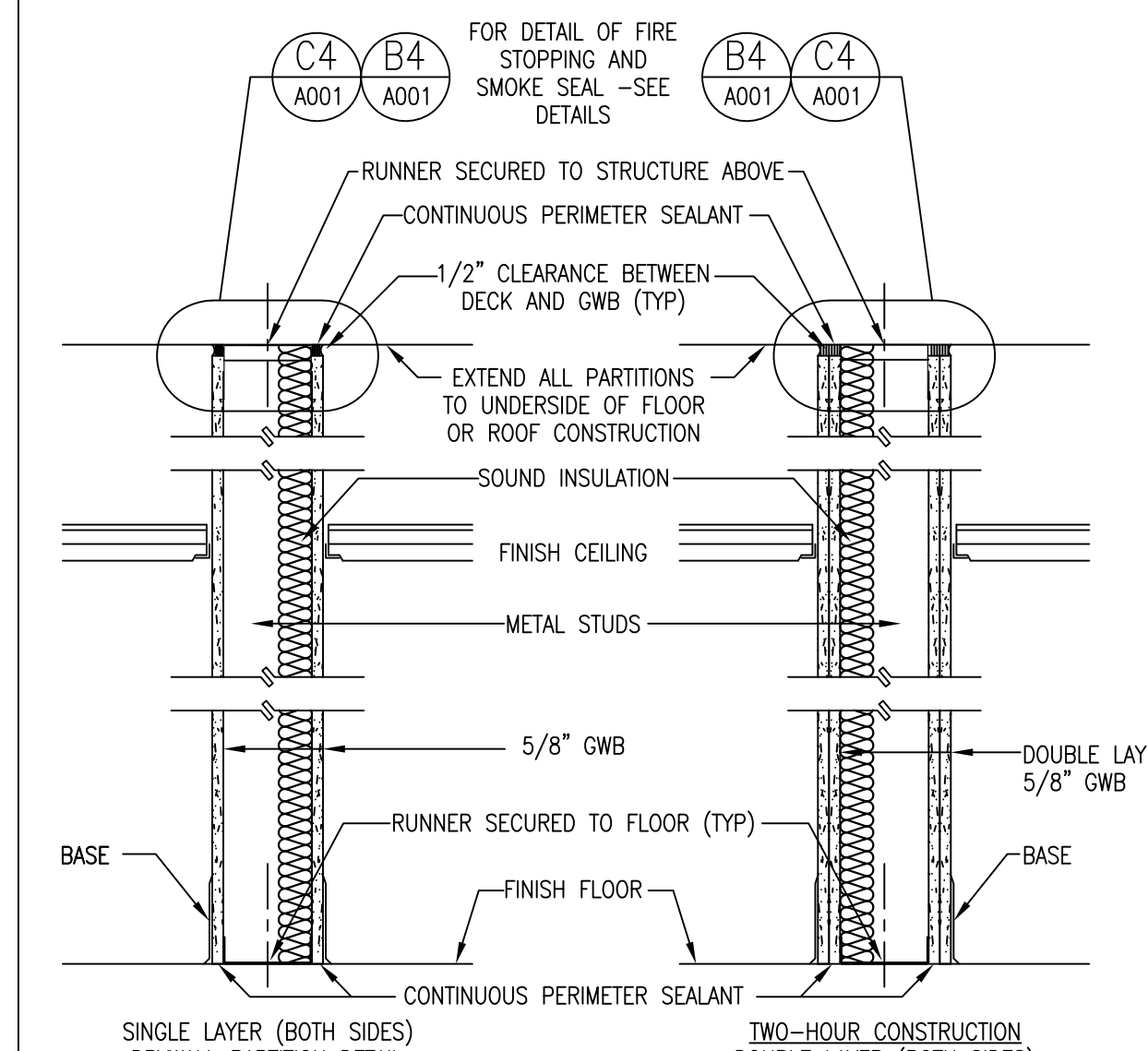

- TYPE **A3** NON-RATED (STC 45) ONE LAYER 5/8\"/>
- TYPE **A4** NON-RATED (STC 45) ONE LAYER 5/8\"/>
- TYPE **A5** 1 HR RATED (STC 45) ONE LAYER 5/8\"/>
- TYPE **A6** 1 HR RATED (STC 45) ONE LAYER 5/8\"/>

**A3 PARTITION TYPE SCHEDULE**  
SCALE: 1 1/2\"/>

NOTE: AT GROUND AND FIFTH FLOORS, ALL INTERIOR PARTITIONS SHALL BE CONSTRUCTED WITH COLD FORMED METAL FRAMING

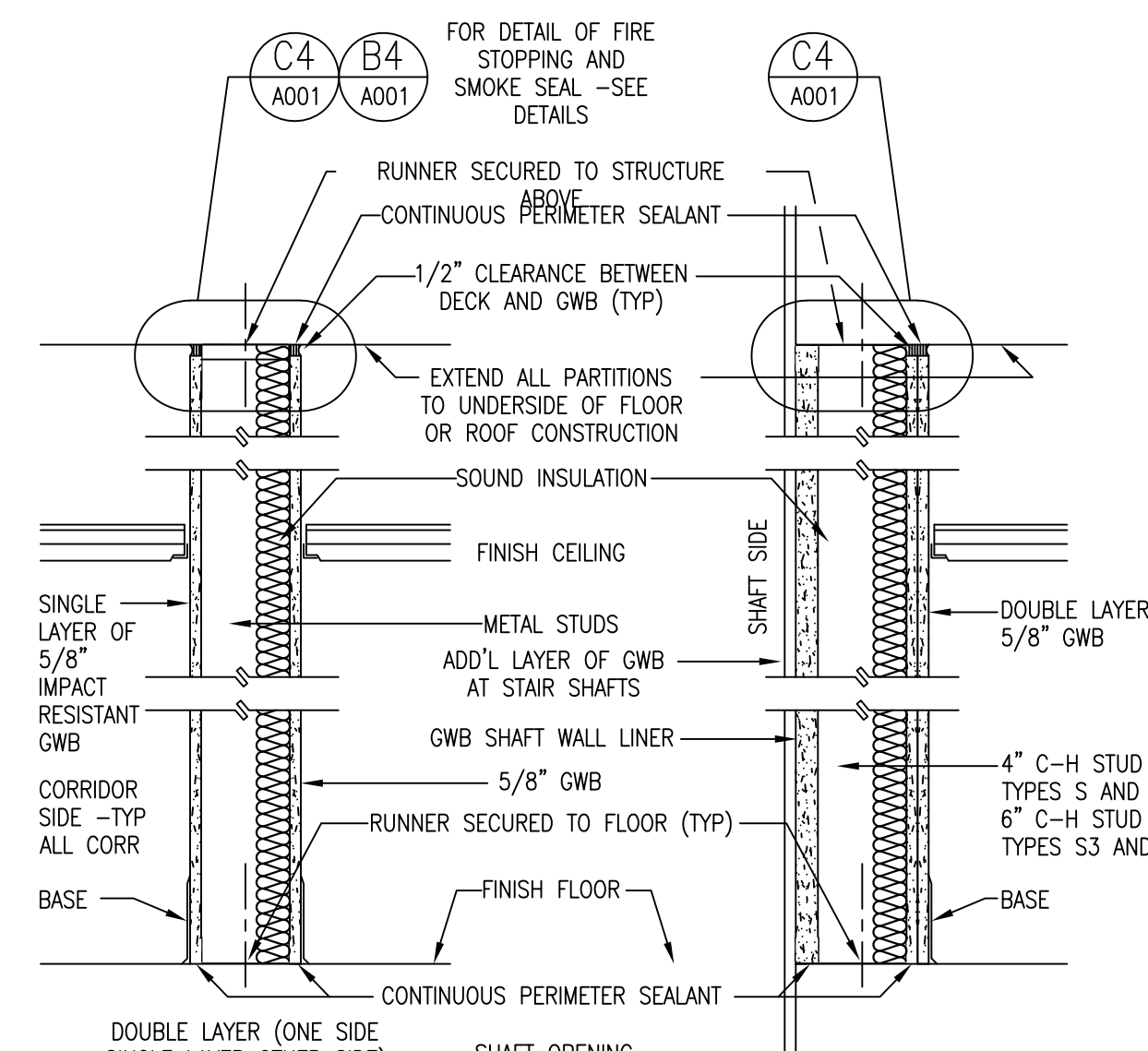

- TYPE **C3** NON-RATED (STC 45) ONE LAYER 5/8\"/>
- TYPE **C4** NON-RATED (STC 45) ONE LAYER 5/8\"/>
- TYPE **C5** 1 HR RATED (STC 45) ONE LAYER 5/8\"/>
- TYPE **C6** 1 HR RATED (STC 45) ONE LAYER 5/8\"/>

**C3 PARTITION TYPES SCHEDULE**  
SCALE: 1 1/2\"/>

NOTE: AT GROUND AND FIFTH FLOORS, ALL INTERIOR PARTITIONS SHALL BE CONSTRUCTED WITH COLD FORMED METAL FRAMING

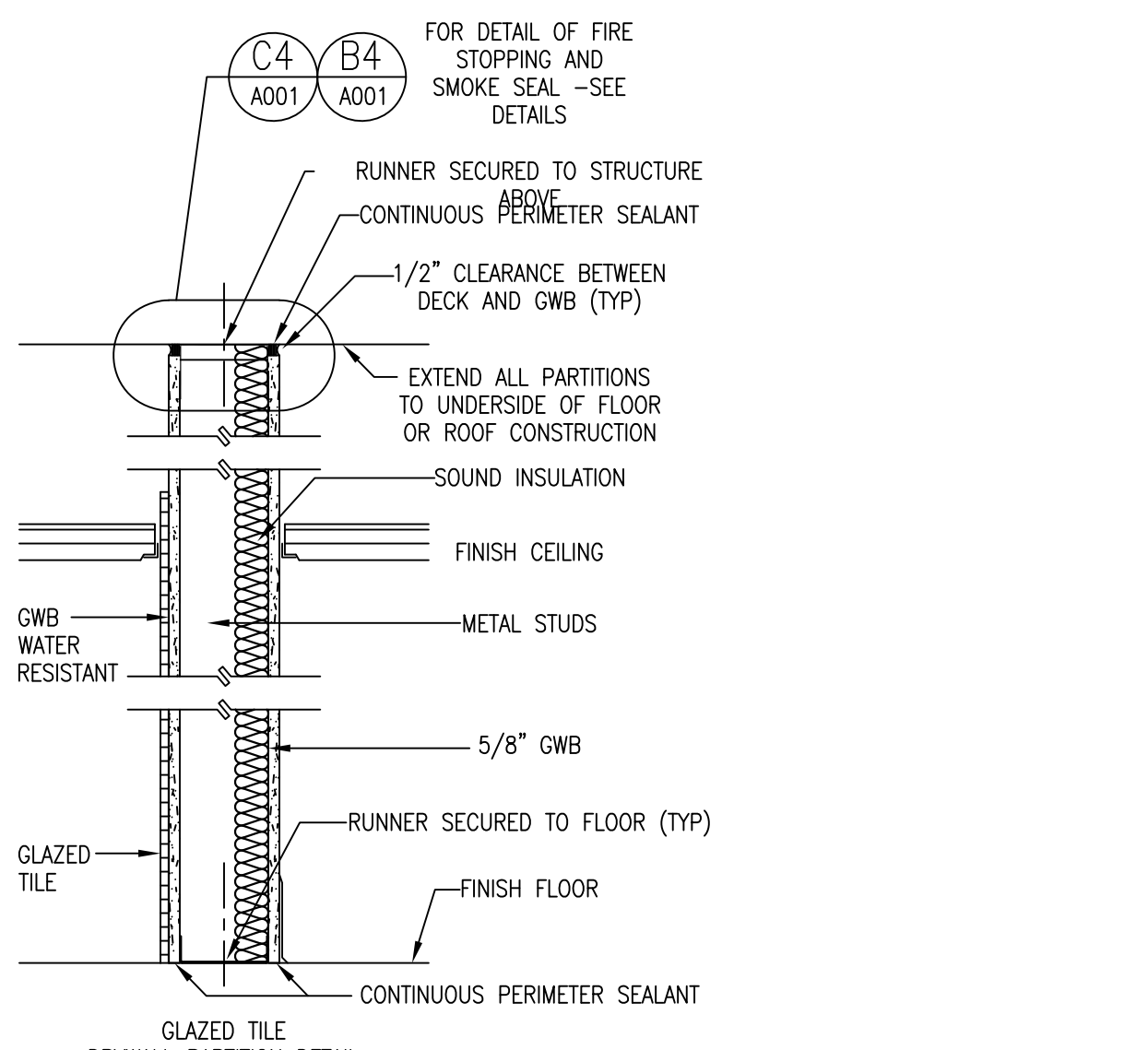

- TYPE **D3** NON-RATED (STC 45) ONE LAYER 5/8\"/>
- TYPE **D4** NON-RATED (STC 45) ONE LAYER 5/8\"/>
- TYPE **D5** 1 HR RATED (STC 45) ONE LAYER 5/8\"/>
- TYPE **D6** 1 HR RATED (STC 45) ONE LAYER 5/8\"/>

**D3 PARTITION TYPES SCHEDULE**  
SCALE: 1 1/2\"/>

NOTE: AT GROUND AND FIFTH FLOORS, ALL INTERIOR PARTITIONS SHALL BE CONSTRUCTED WITH COLD FORMED METAL FRAMING

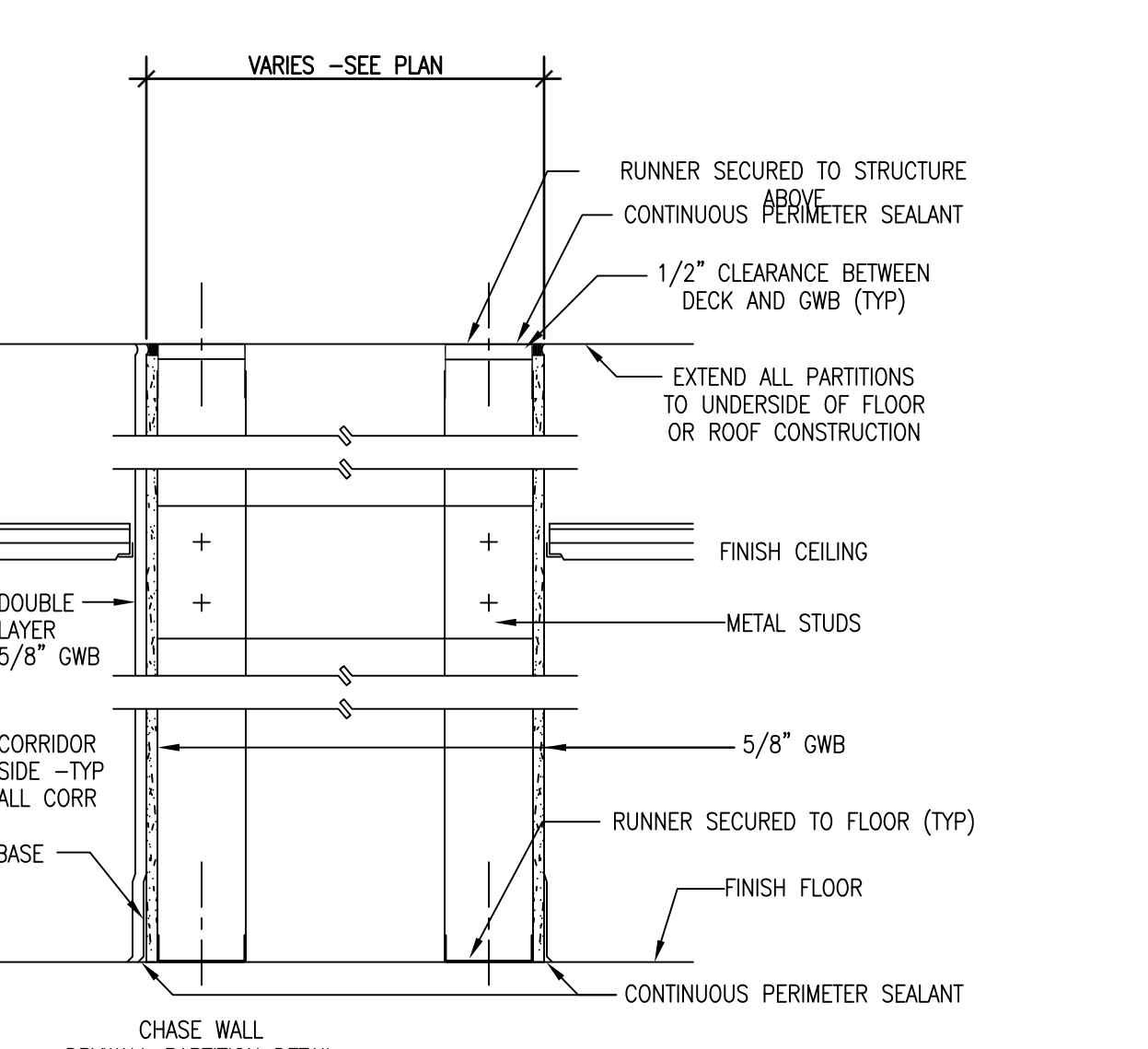

- TYPE **E3** NON-RATED (STC 45) ONE LAYER 5/8\"/>
- TYPE **E4** NON-RATED (STC 45) ONE LAYER 5/8\"/>
- TYPE **E5** NON-RATED (STC 45) ONE LAYER 5/8\"/>
- TYPE **E6** NON-RATED (STC 45) ONE LAYER 5/8\"/>

**E3 PARTITION TYPES SCHEDULE**  
SCALE: 1 1/2\"/>

NOTE: AT GROUND AND FIFTH FLOORS, ALL INTERIOR PARTITIONS SHALL BE CONSTRUCTED WITH COLD FORMED METAL FRAMING

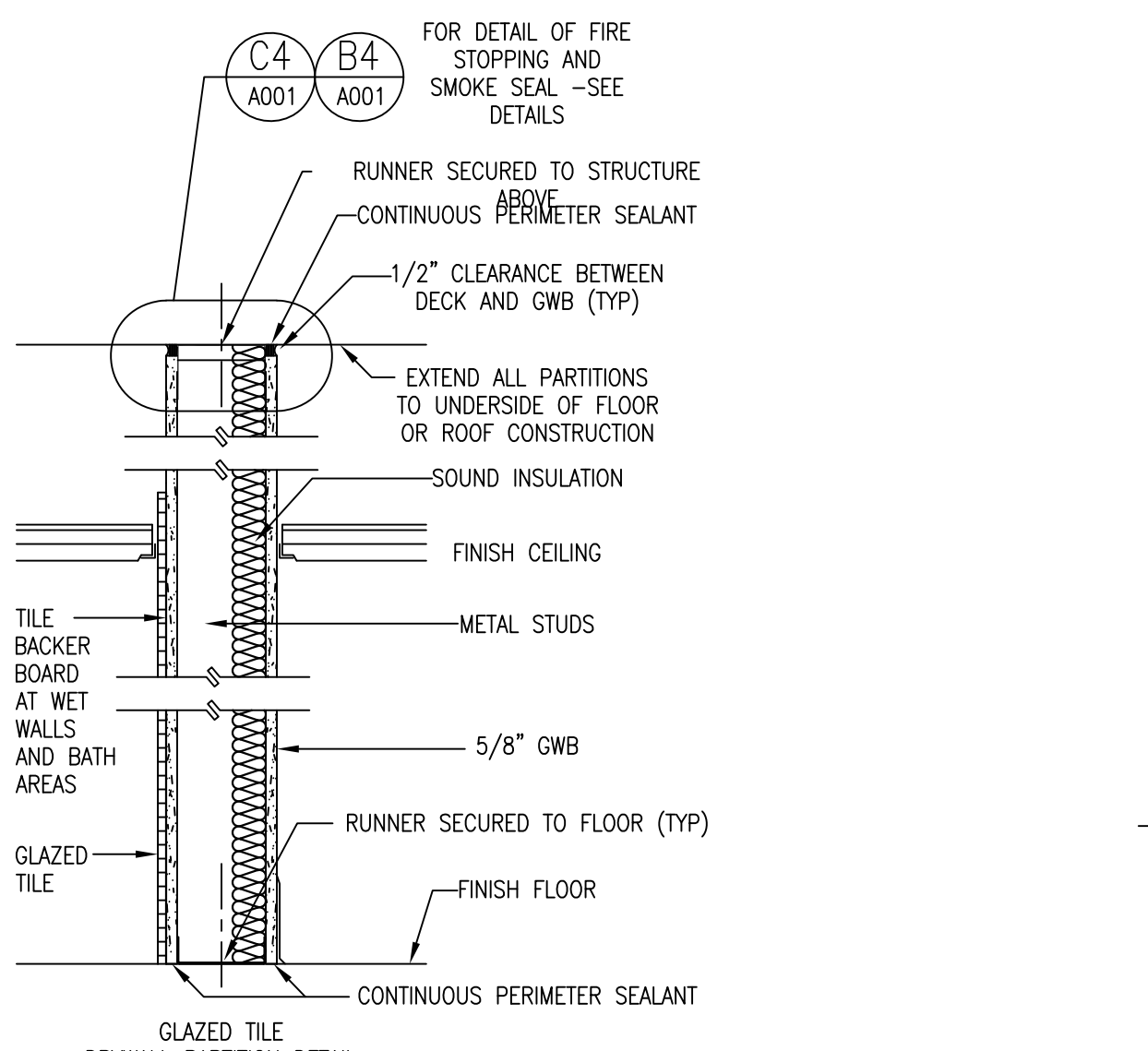

- TYPE **F3** NON-RATED (STC 45) ONE LAYER 5/8\"/>
- TYPE **F4** NON-RATED (STC 45) ONE LAYER 5/8\"/>
- TYPE **F5** 1 HR RATED (STC 45) ONE LAYER 5/8\"/>
- TYPE **F6** 1 HR RATED (STC 45) ONE LAYER 5/8\"/>

**F3 PARTITION TYPES SCHEDULE**  
SCALE: 1 1/2\"/>

MARK	ISSUE DATE	DESCRIPTION
ADD 05	04/28/06	ADDENDUM NUMBER 05 - PACKAGE H
ADD 03	01/26/06	ADDENDUM NUMBER 03 - PACKAGE H
PERMIT	09/24/04	PERMIT SET - NOT FOR CONSTRUCTION

Issue Log

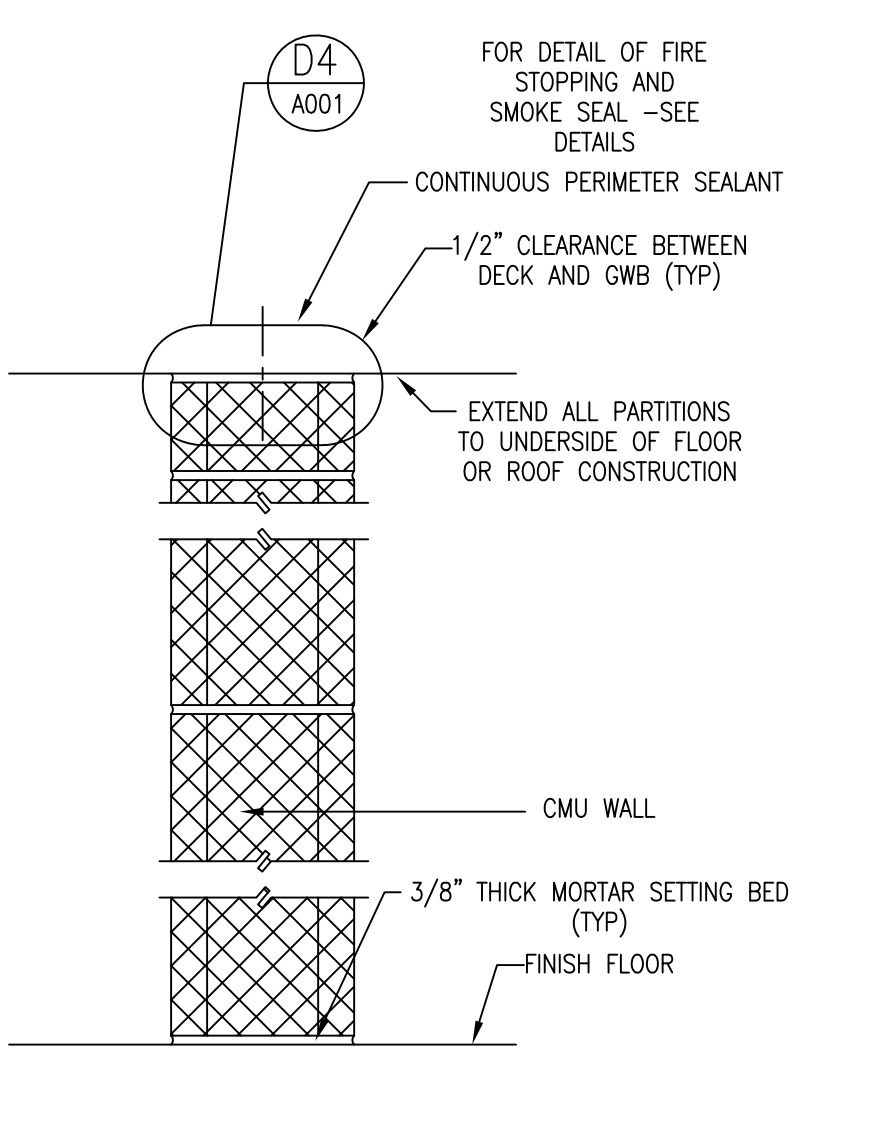

- TYPE **M1** NON-RATED (5.5/8\"/>
- TYPE **M2** NON-RATED (7.5/8\"/>
- TYPE **M3** 2 HR RATED (5.5/8\"/>
- TYPE **M4** 2 HR RATED (7.5/8\"/>

**A3 PARTITION TYPE SCHEDULE**  
SCALE: 1 1/2\"/>

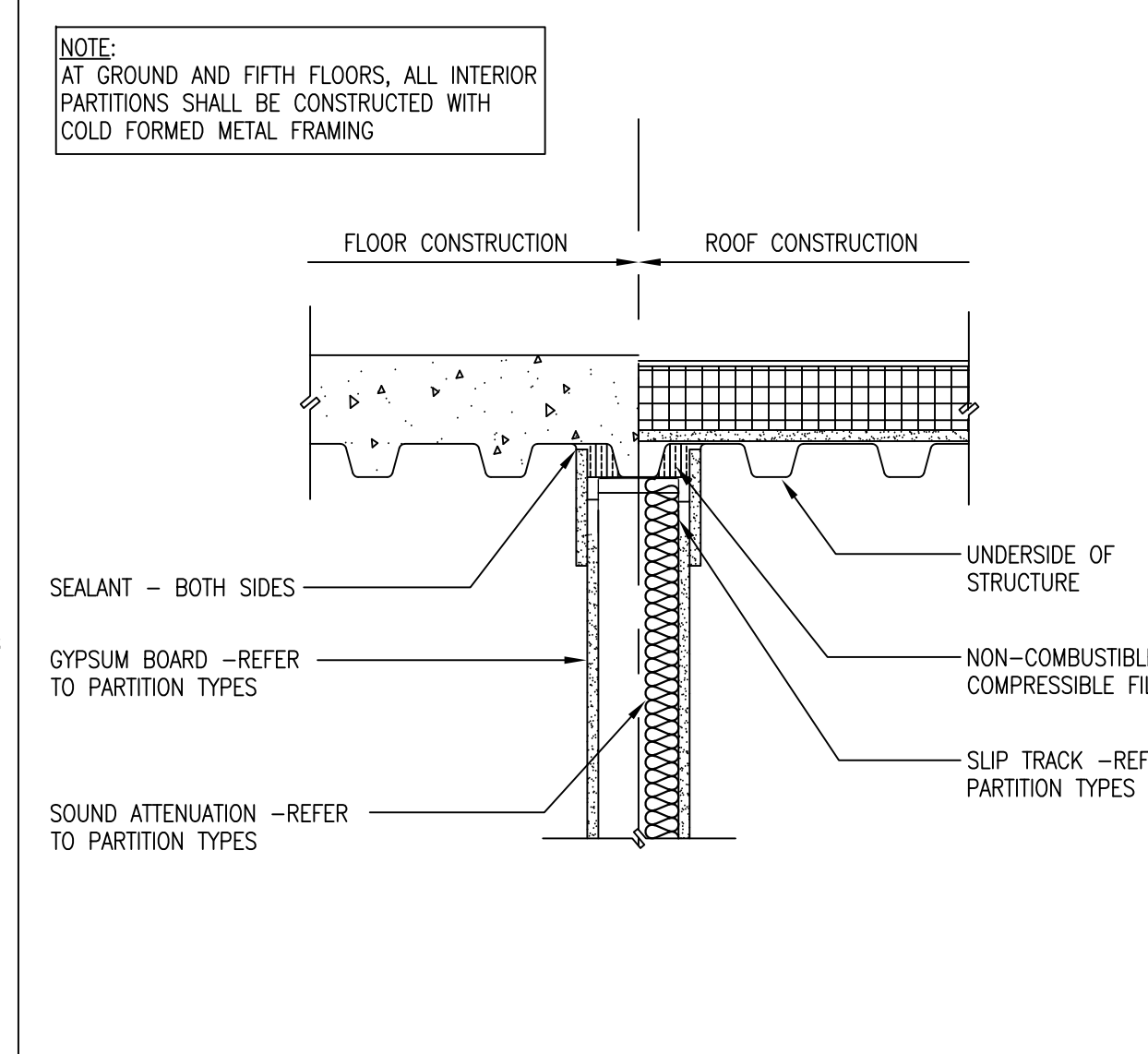

**B4 NON-RATED PARTITION -TOP OF WALL DETAIL**  
SCALE: 1 1/2\"/>

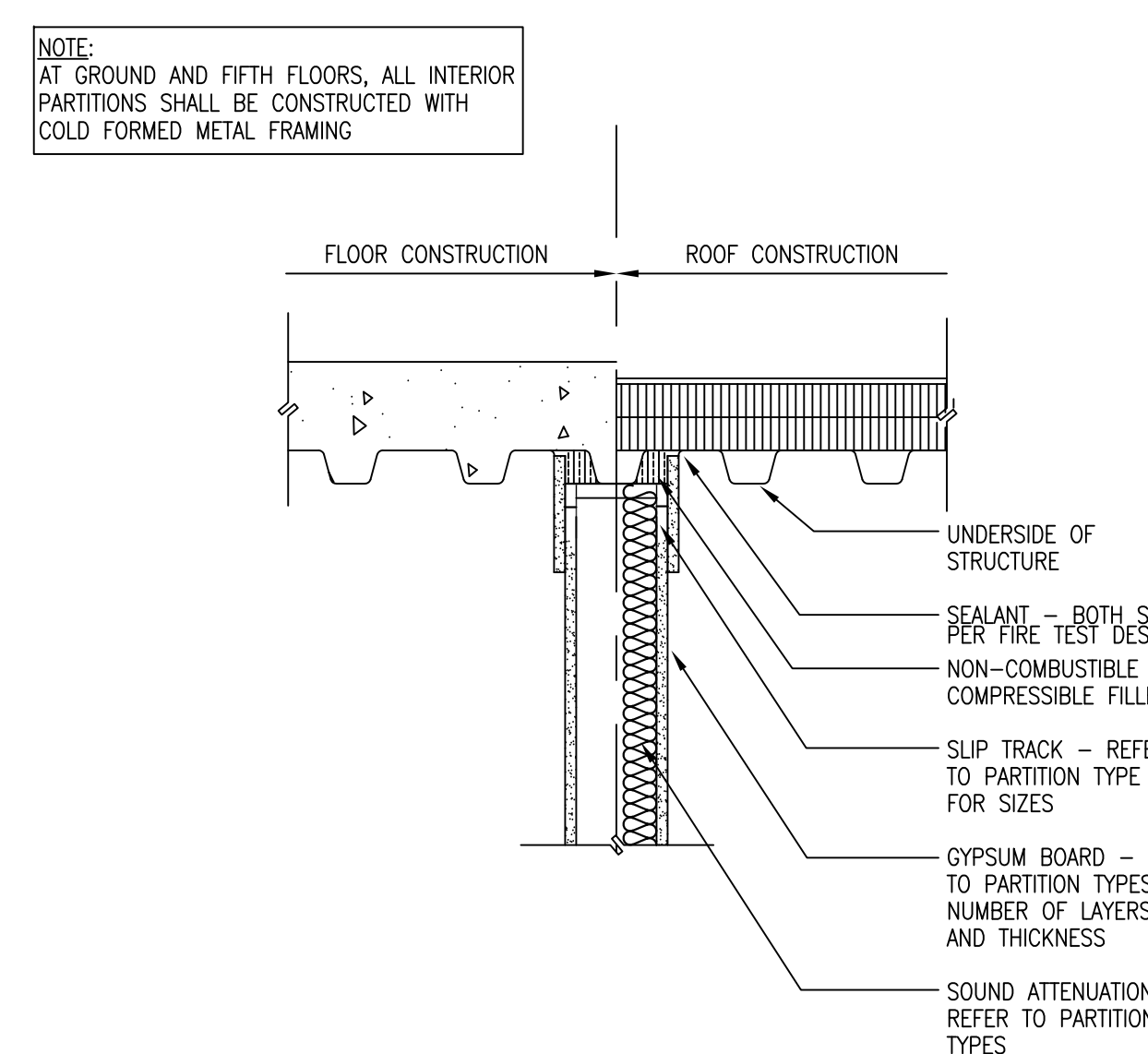

**C4 RATED PARTITION -TOP OF WALL DETAIL**  
SCALE: 1 1/2\"/>

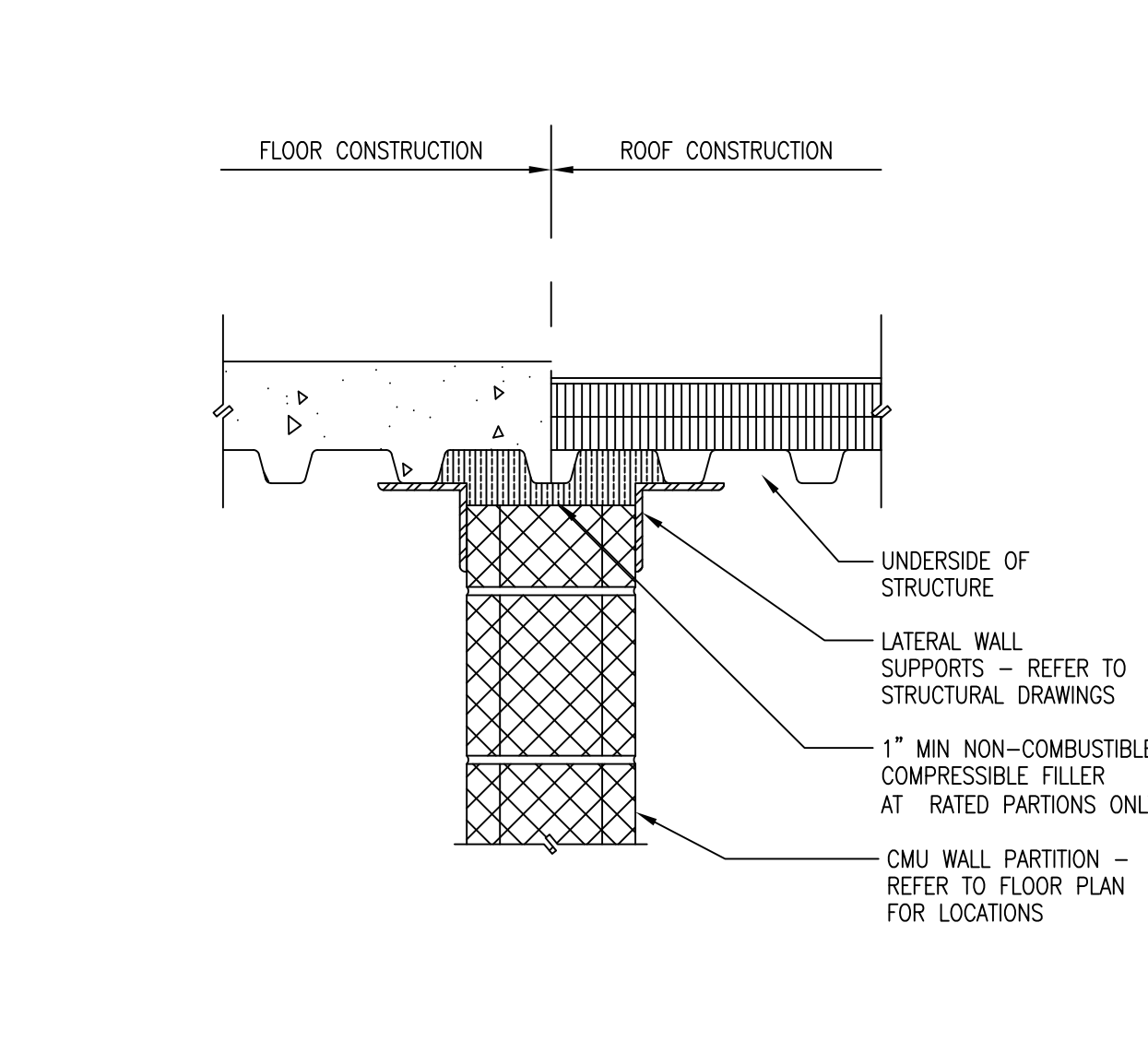

**D4 CMU PARTITION -TOP OF WALL DETAIL**  
SCALE: 1 1/2\"/>

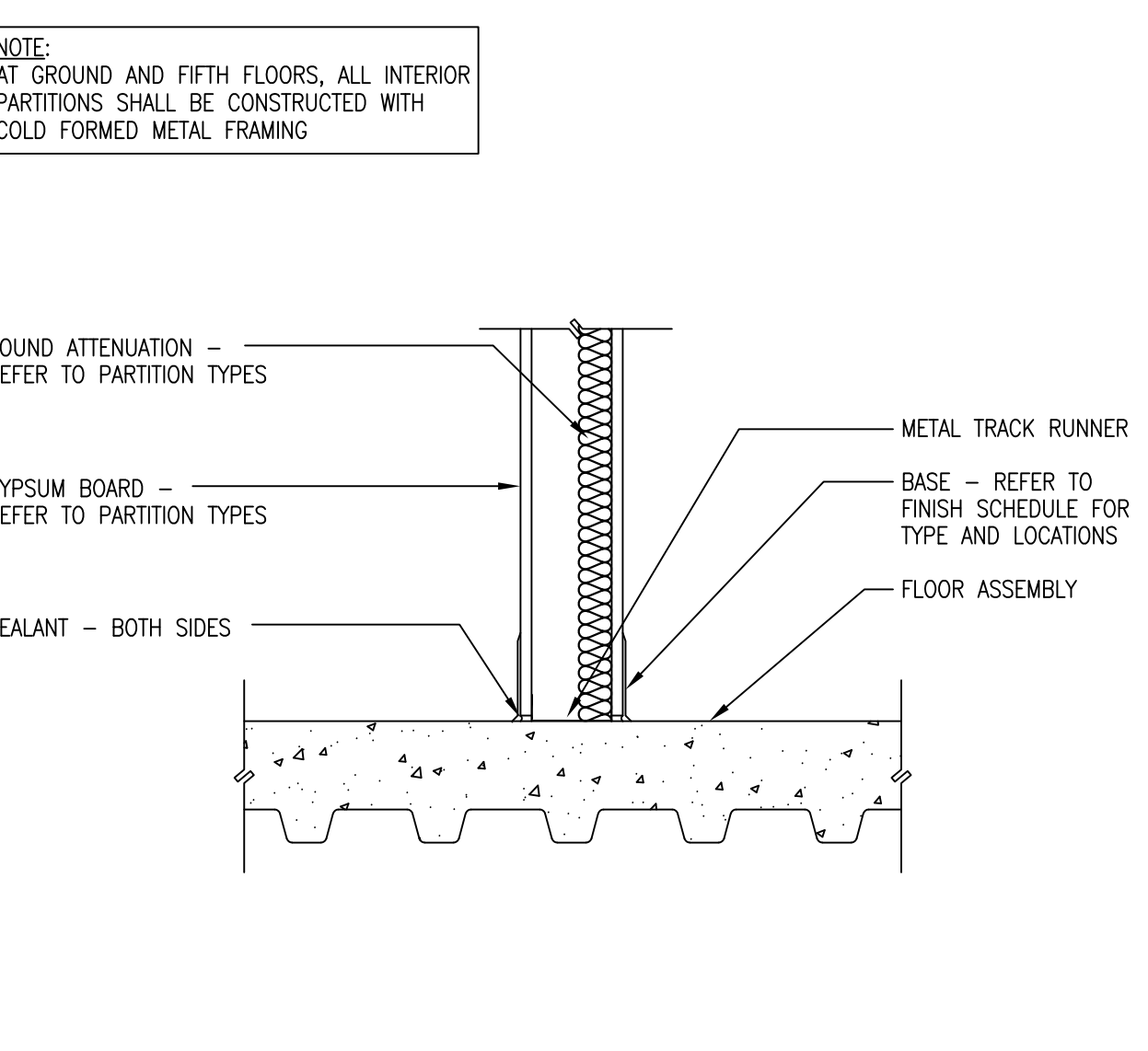

**E4 BOTTOM OF WALL DETAIL**  
SCALE: 1 1/2\"/>

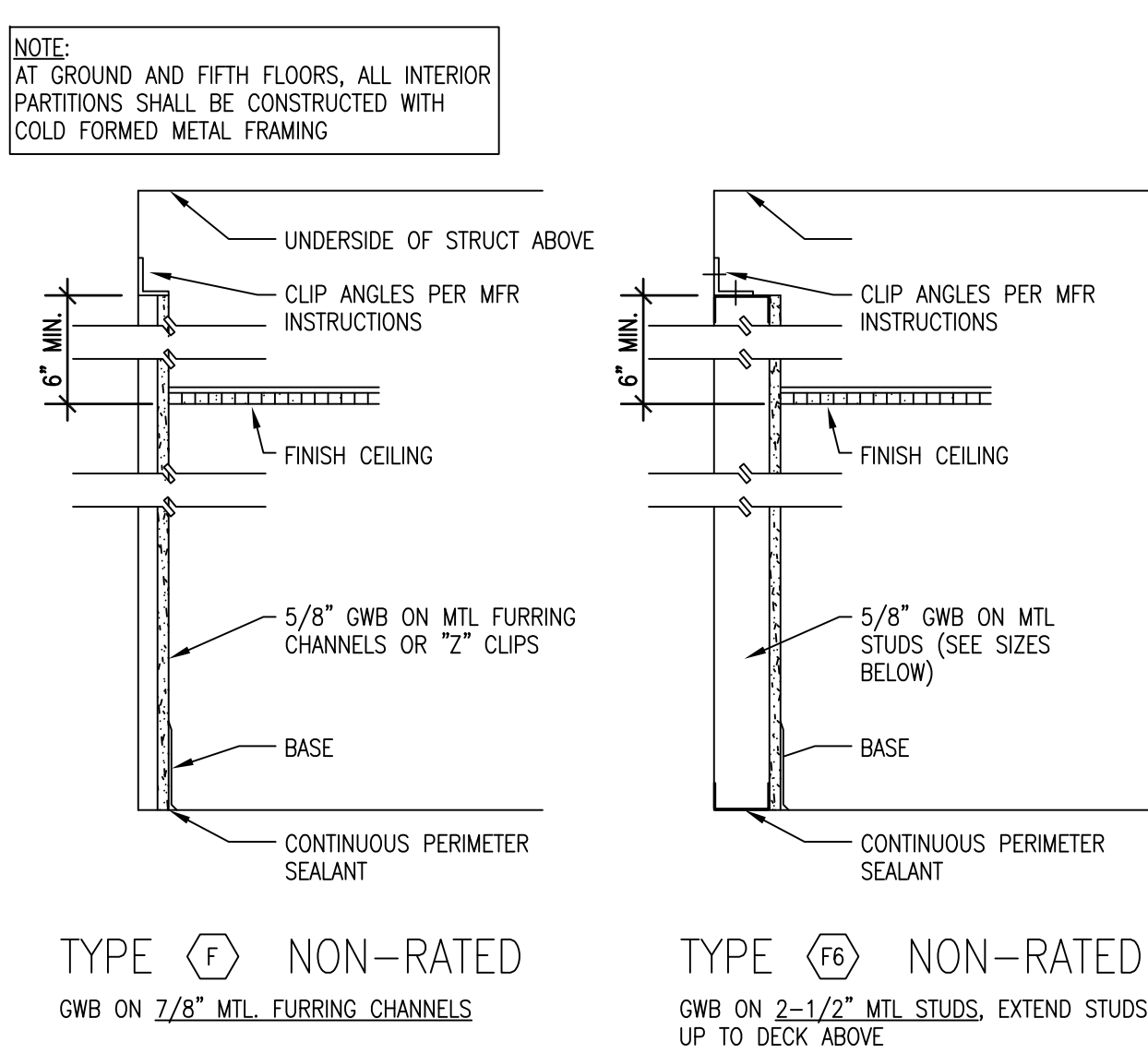

**F5 WALL FURRING TYPES**  
SCALE: 1 1/2\"/>

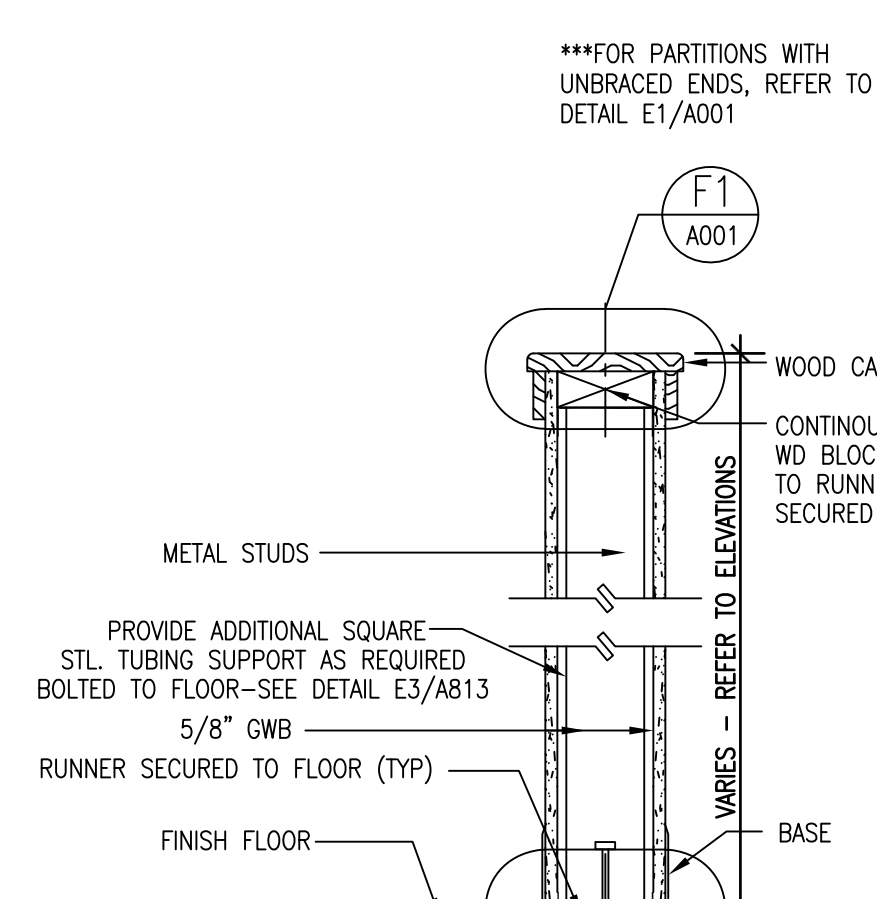

- TYPE **A3** NON-RATED ONE LAYER EACH SIDE ON 3.5/8\"/>
- TYPE **A4** NON-RATED ONE LAYER EACH SIDE ON 6\"/>
- TYPE **A5** NON-RATED DOUBLE LAYER OMB ON CORRIDOR SIDE, SINGLE LAYER ON OTHER SIDE ON 3.5/8\"/>
- TYPE **A6** NON-RATED DOUBLE LAYER OMB ON CORRIDOR SIDE, SINGLE LAYER ON OTHER SIDE ON 6\"/>

**D2 PARTITION TYPES SCHEDULE**  
SCALE: 1 1/2\"/>

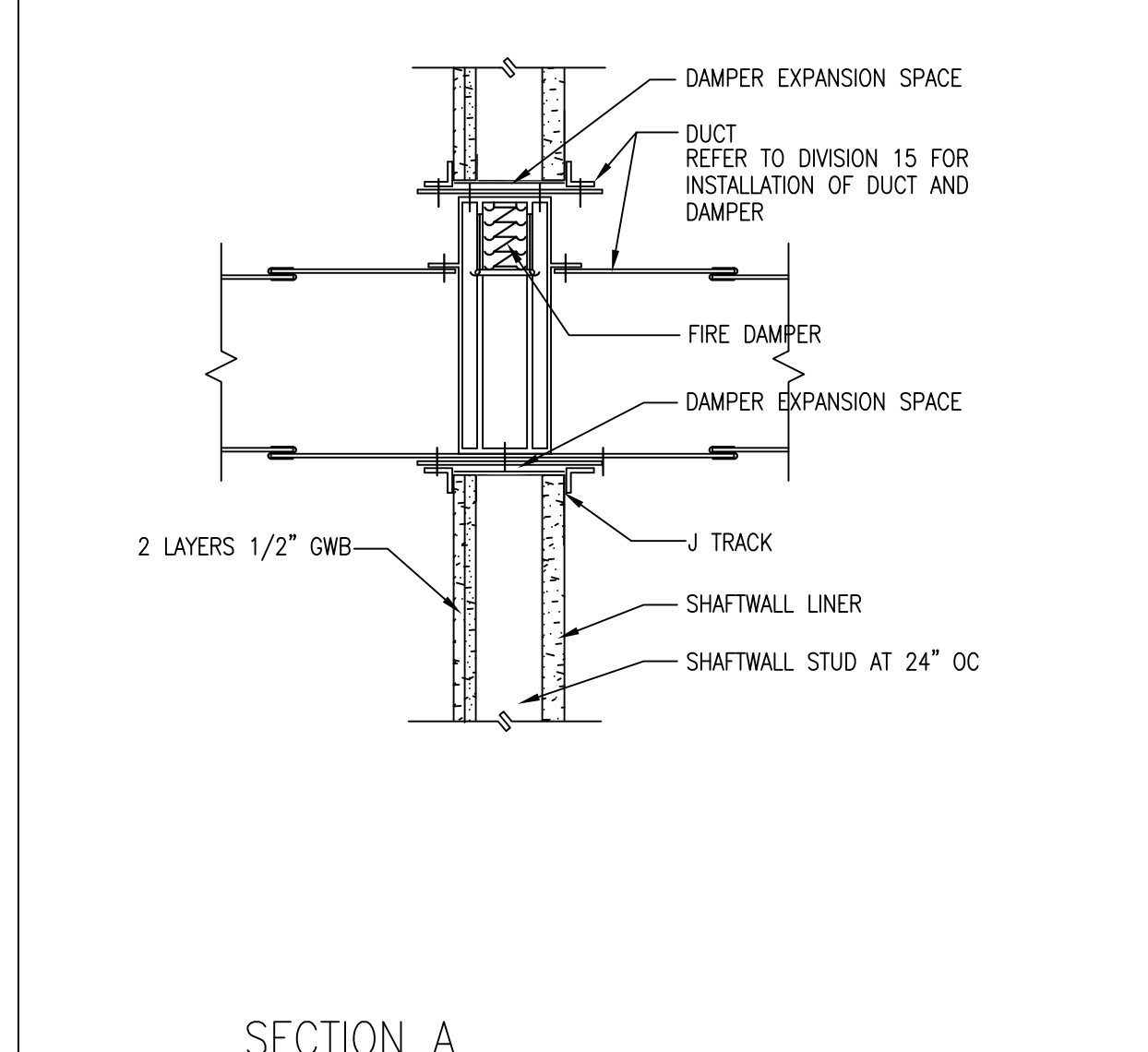

**B5 SECTION A DUCT OPENING INTO 2-HOUR SHAFT WALL**  
SCALE: 1 1/2\"/>

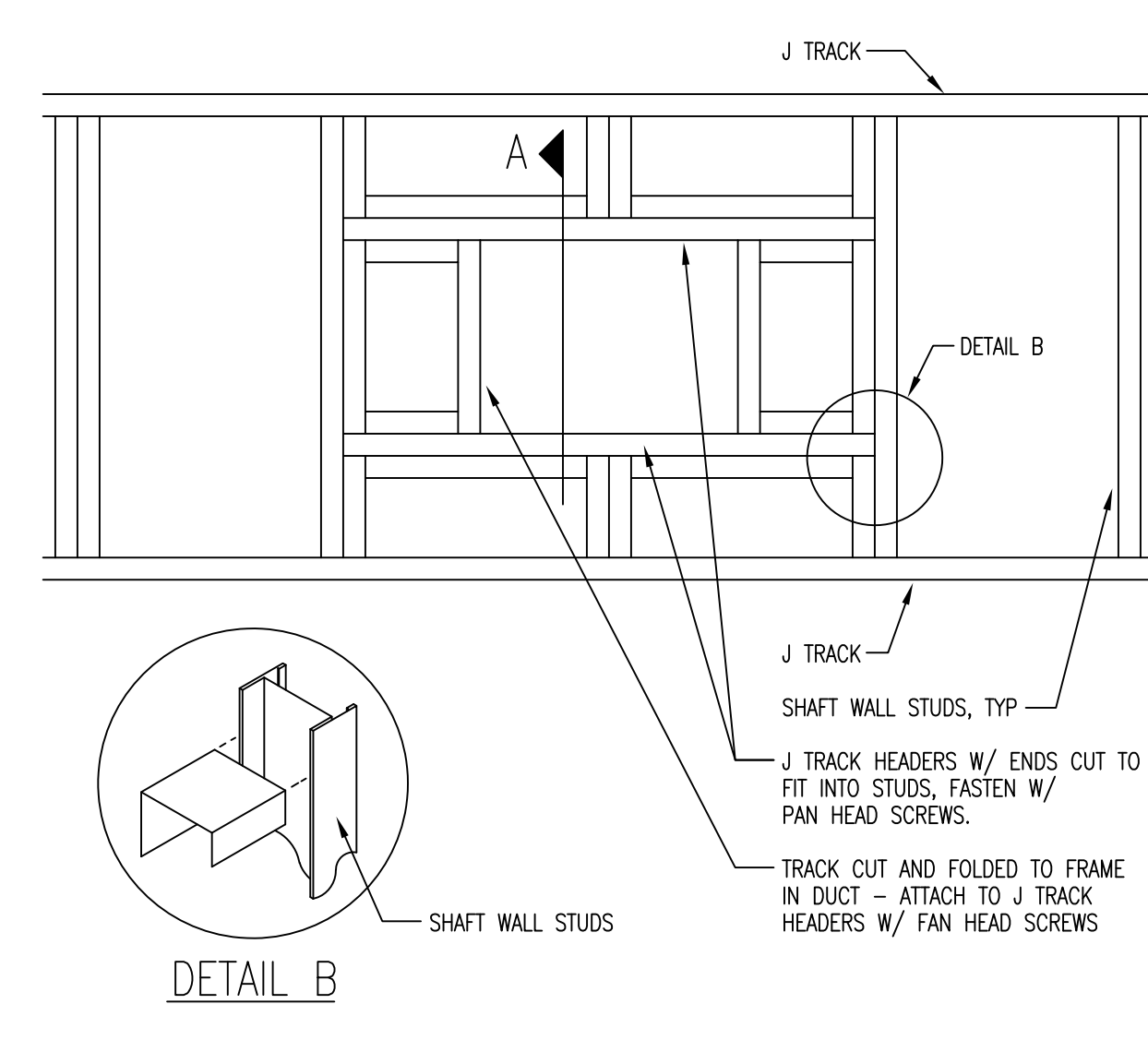

**C5 DUCT OPENING INTO 2-HOUR SHAFT WALL**  
SCALE: 1 1/2\"/>

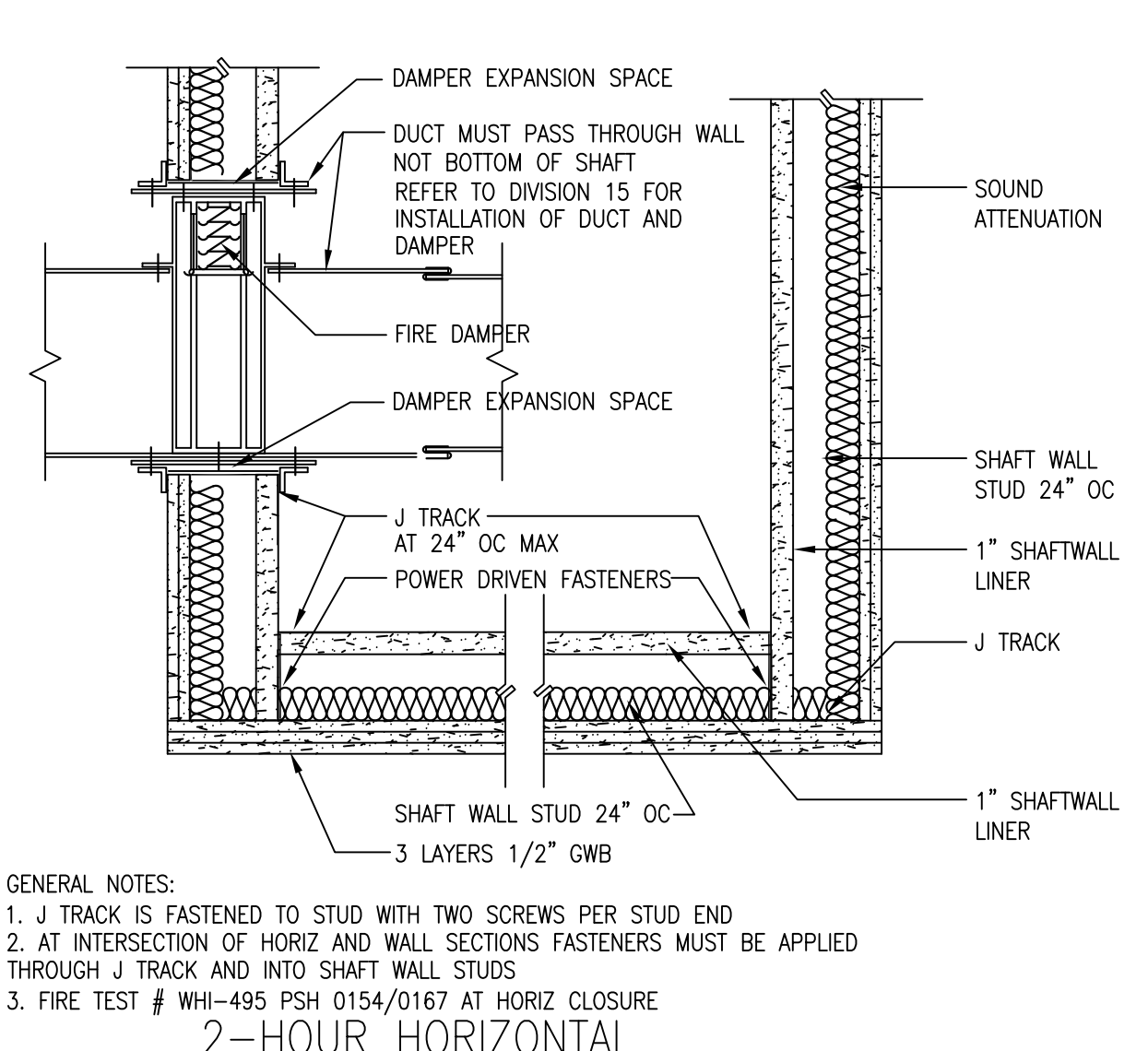

**D5 2-HOUR HORIZONTAL SHAFT WALL SHAFT CLOSURE**  
SCALE: 1 1/2\"/>

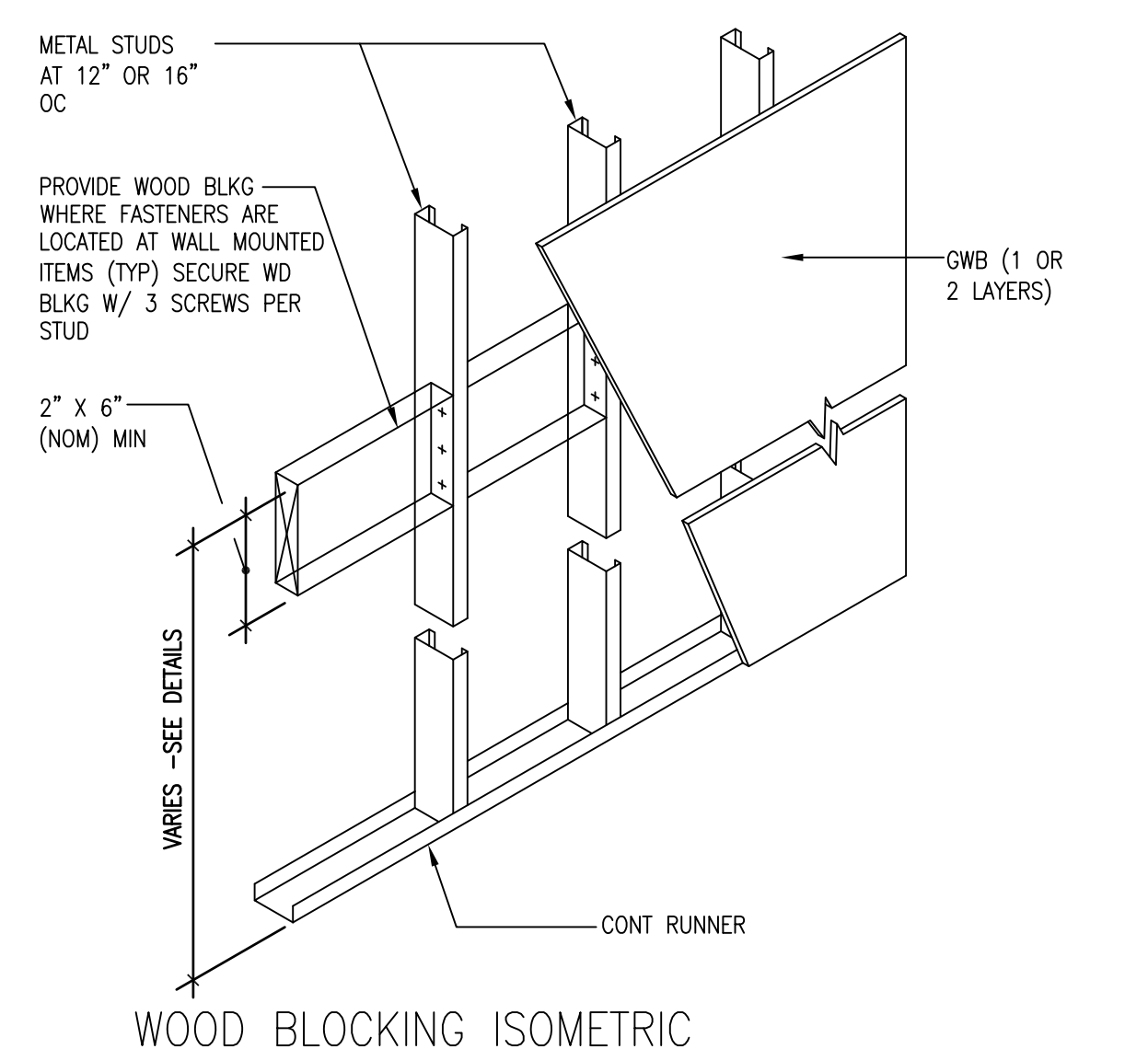

**E5 WOOD BLOCKING ISOMETRIC FOR WALL MOUNTED ITEMS**  
SCALE: 3/4\"/>

Key Plan

Drawing Title  
**PARTITION SCHEDULE AND DETAILS**

Commission No.	AS NOTED	Date Issued
Scale	AS NOTED	Sheet Number
Drawn By	JW	
Approved By	JW	
Filename	lpg_m_14673001.dwg	

A001