

CONSULTANTS

CIVIL/LANDSCAPE ARCHITECT  
**Sebago Technics**  
75 John Roberts Road, Suite  
1A, South Portland, ME 04106

STRUCTURAL/ENR/BUILDING ENVELOPE CONSULTANT  
**Simpson Gumpertz & Heger Inc.**  
41 Seyon Street, Building 1, Suite 570,  
Waltham, MA 02453

MEP/ELECTRICAL ENGINEER  
**AKF Group LLC**  
99 Bedford Street, 2nd Floor, Boston MA 02111

CONSTRUCTION MANAGER  
**Turner Construction**  
2 Seaport Lane, Suite 200, Boston, MA 02210

ELEVATOR CONSULTANT  
**VDA (Van Deusen & Associates)**  
101 Summer Street, 4th Floor, Boston MA  
02110

COST ESTIMATOR  
**D. G. Jones International**  
3 Baldwin Green Common, Suite 202, Woburn, MA 01801

PROJECT TITLE

**East Tower 6 & 7  
Addition**  
22 Bramhall Street  
Portland, ME 04102

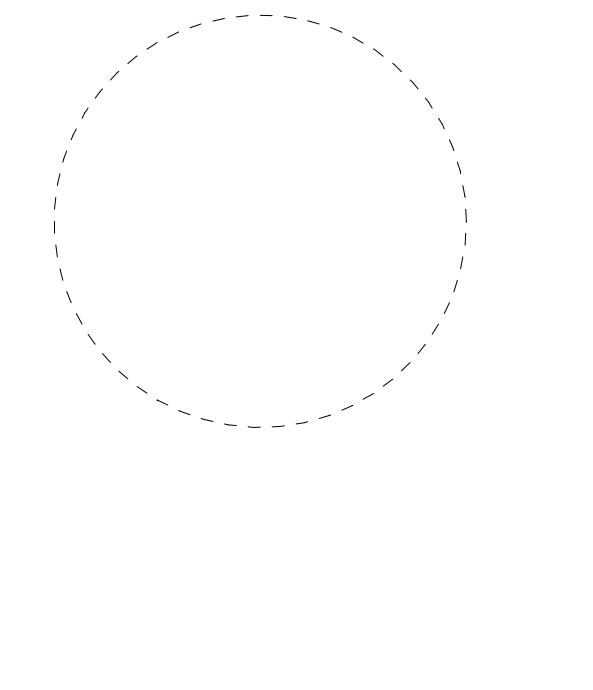

KEY PLANS

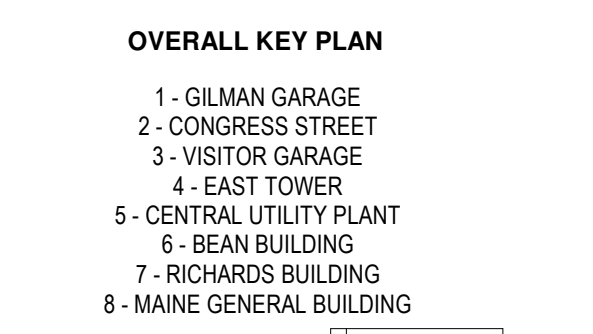
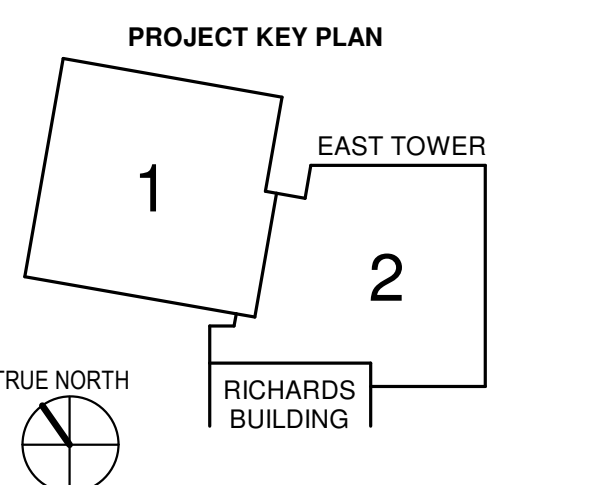

CONSTRUCTION DOCUMENTS  
JANUARY 28, 2018

NO	ISSUE	DATE
1	ADDENDUM NO. 1	03/22/18

Job Number: B150312-000  
Drawn: NV  
Checked: BN  
Approved: BN

TITLE  
**SECURITY DETAILS**

SHEET NUMBER

**SC00-21**

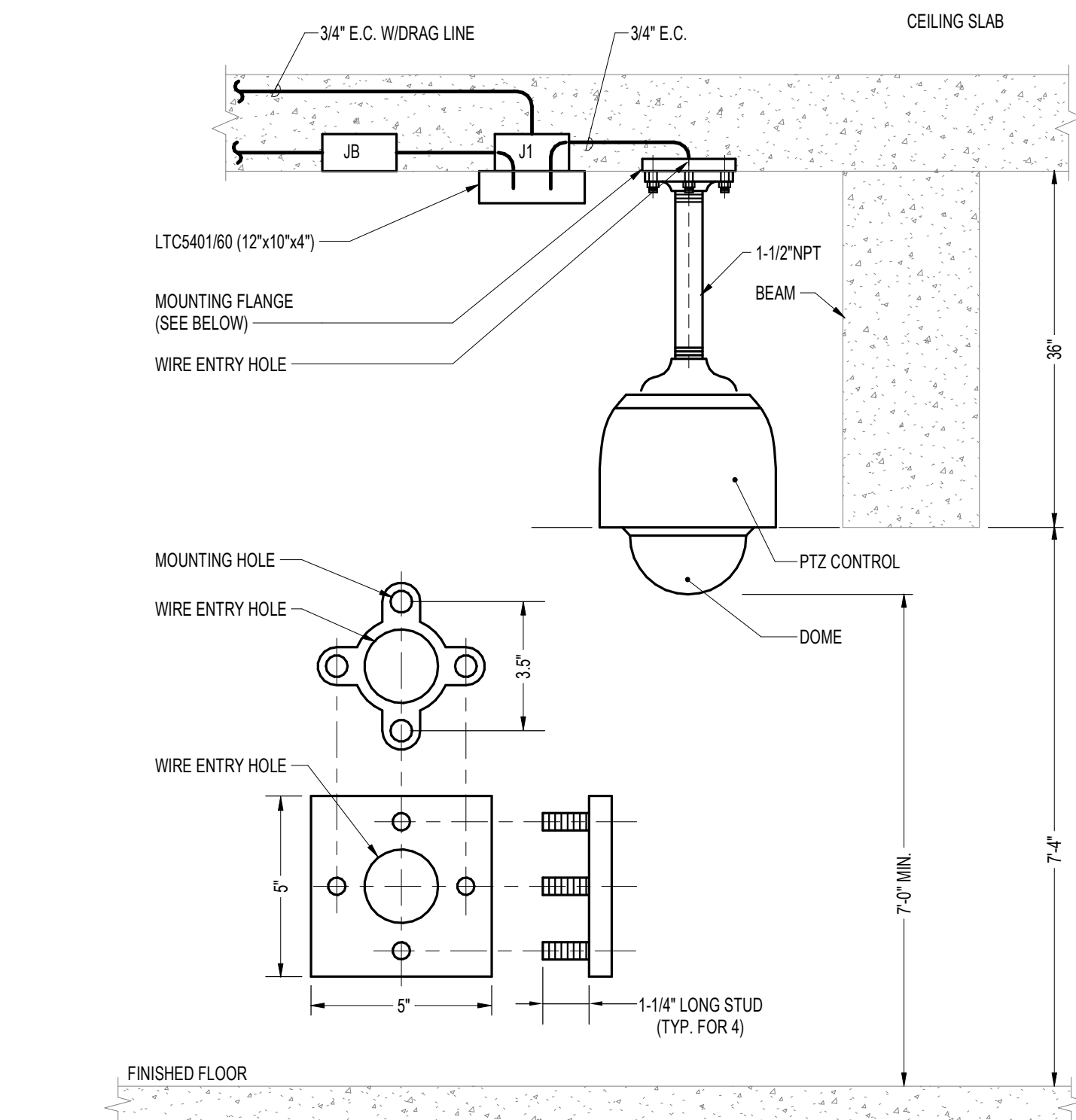

**4** CCTV DOME CAMERA CEILING MOUNT  
SCALE: NONE

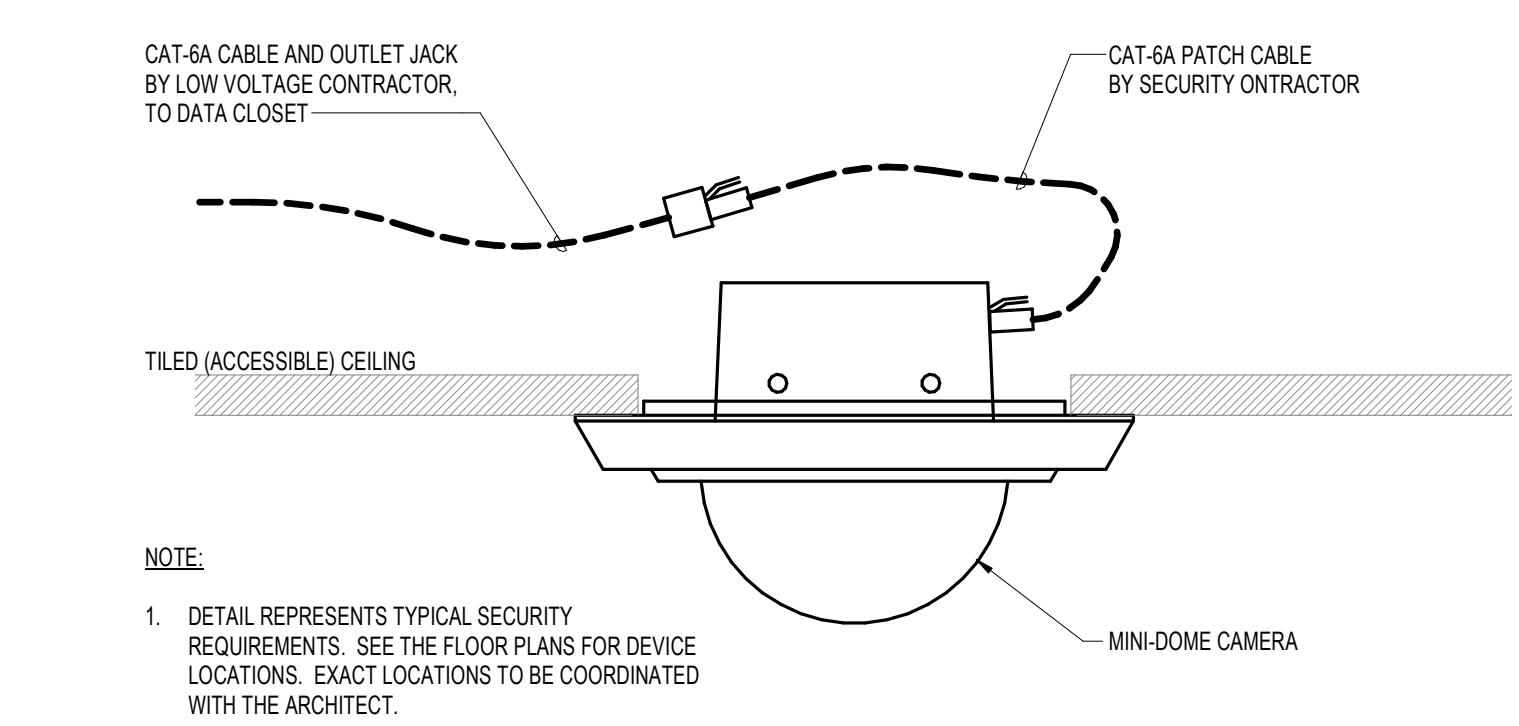

**3** CCTV MINI-DOME CAMERA EXTERIOR-INTERIOR FLUSH CEILING MOUNT  
SCALE: NONE

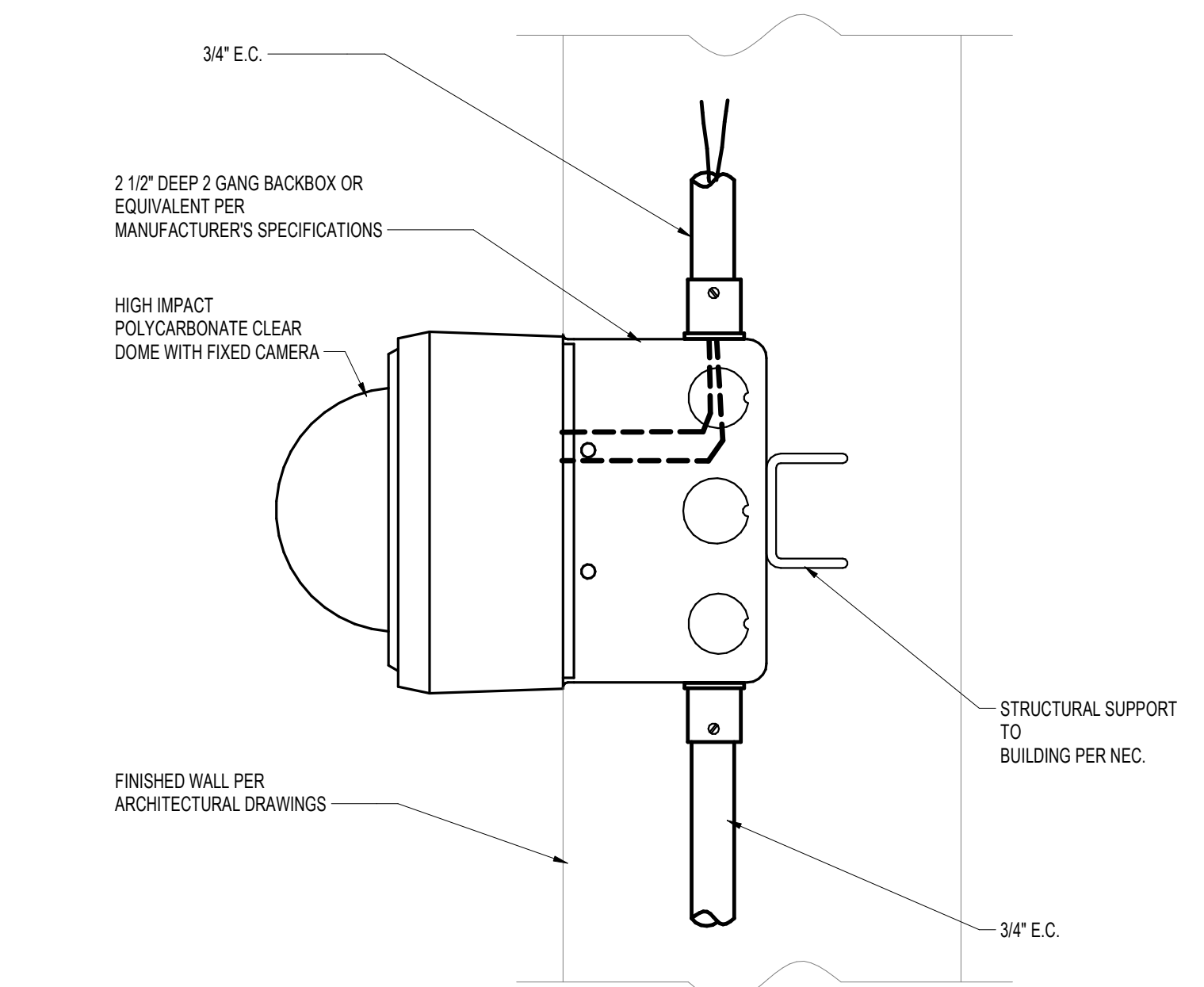

**2** CCTV MINI-DOME CAMERA INTERIOR WALL MOUNT  
SCALE: NONE

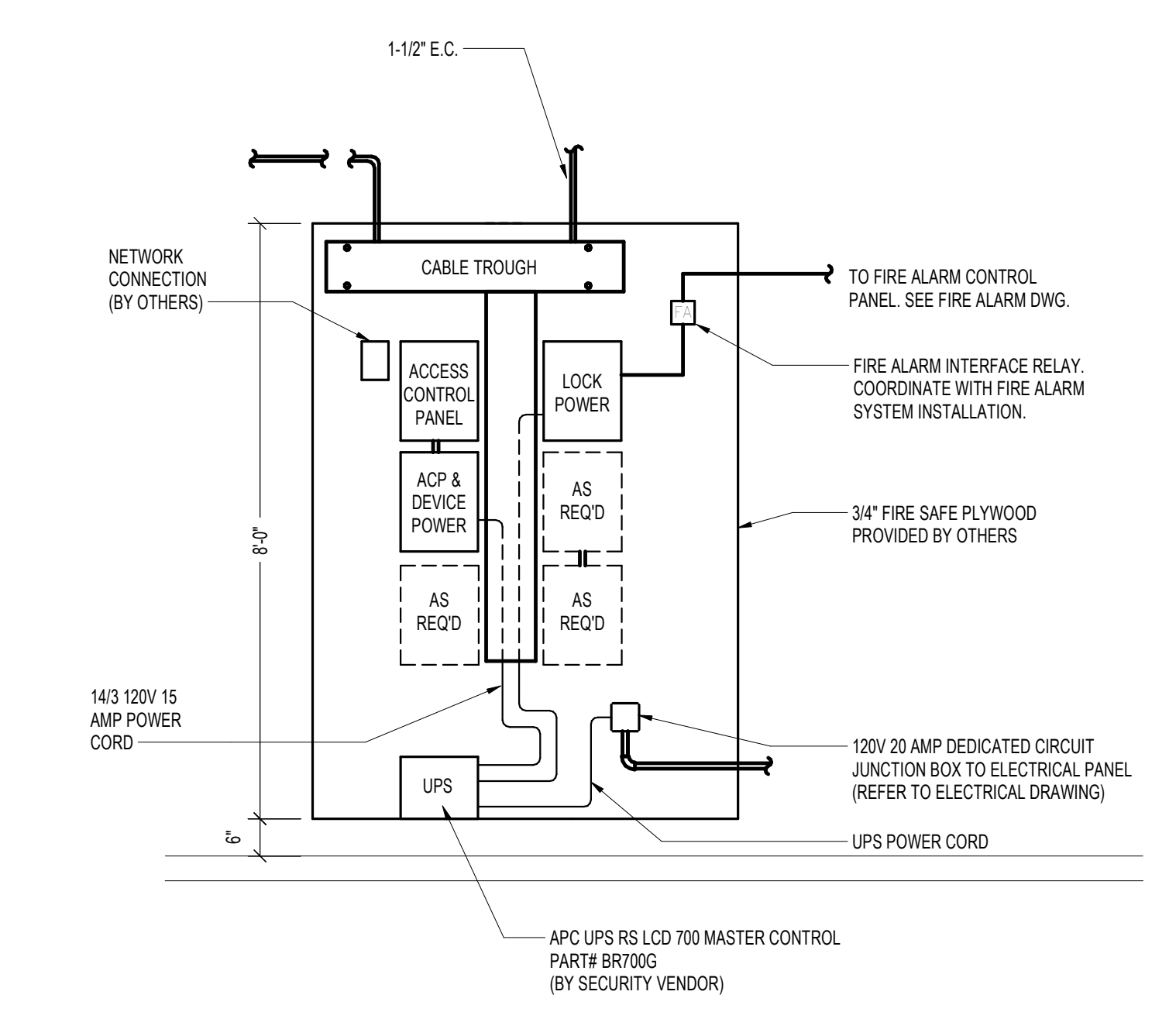

**7** SECURITY DISTRIBUTION FRAME ELEVATION VIEW  
SCALE: NONE

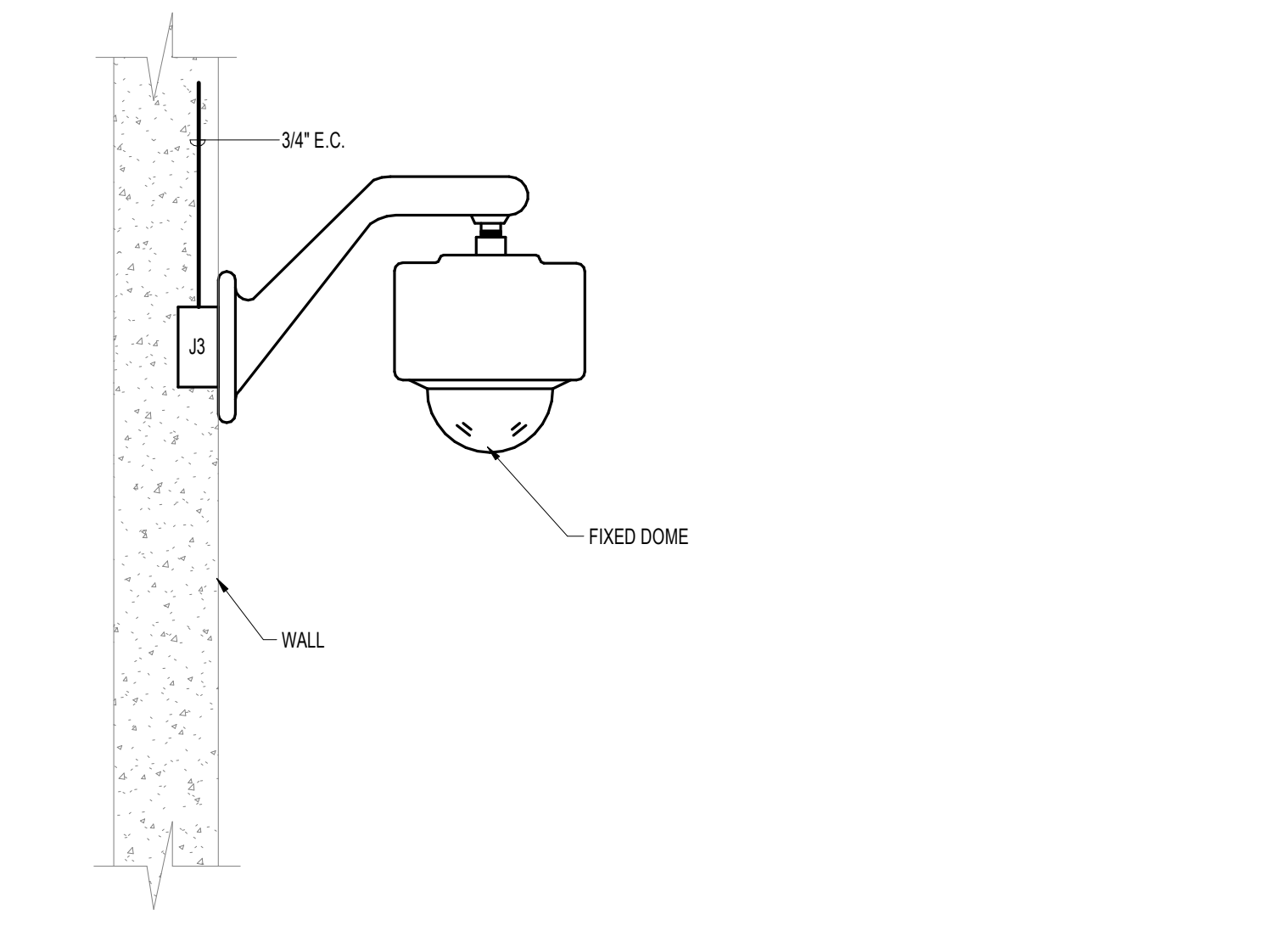

**6** CCTV DOME CAMERA WALL MOUNT  
SCALE: NONE

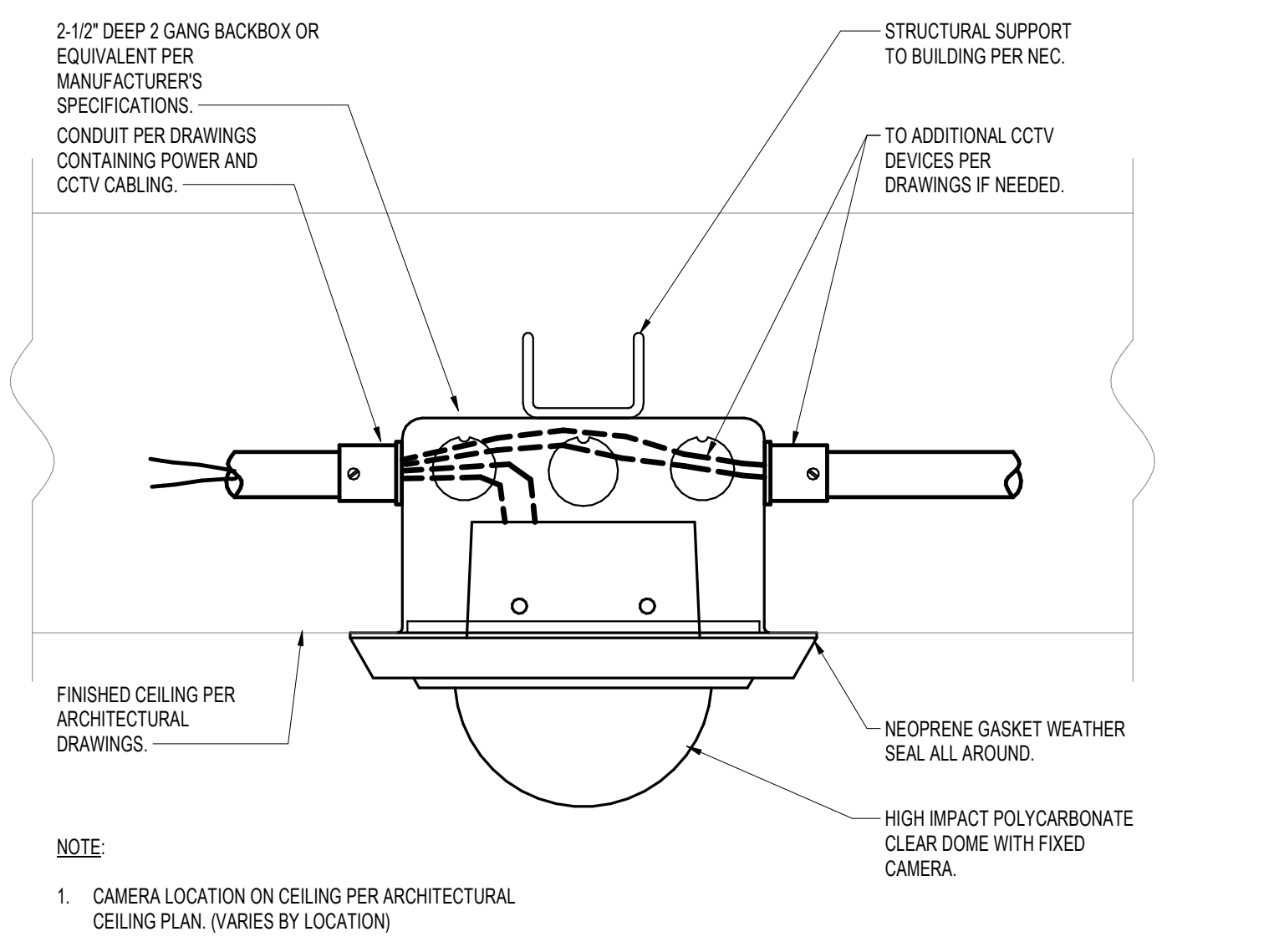

**5** CCTV MINI-DOME CAMERA INTERIOR CEILING MOUNT  
SCALE: NONE

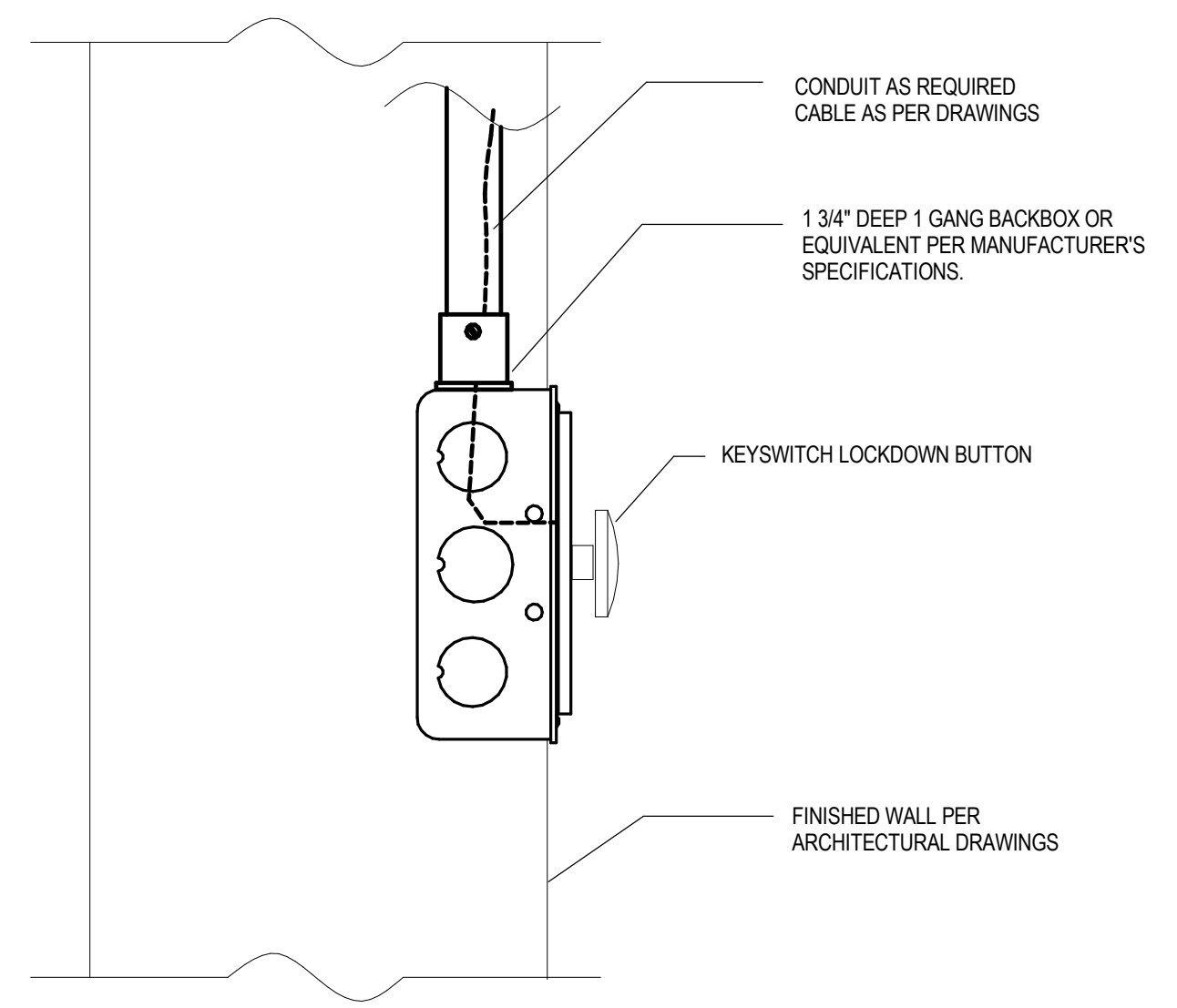

- NOTES:
1. DETAIL REPRESENTS TYPICAL SECURITY REQUIREMENTS
  2. FINAL MOUNTING LOCATIONS TO BE COORDINATED WITH ARCHITECT'S INTERIOR
  3. SEE WIRING/BORING/CEILING PLANS FOR DEVICE LOCATIONS

**10** EMERGENCY LOCKDOWN BUTTON WALL MOUNT  
SCALE: NTS

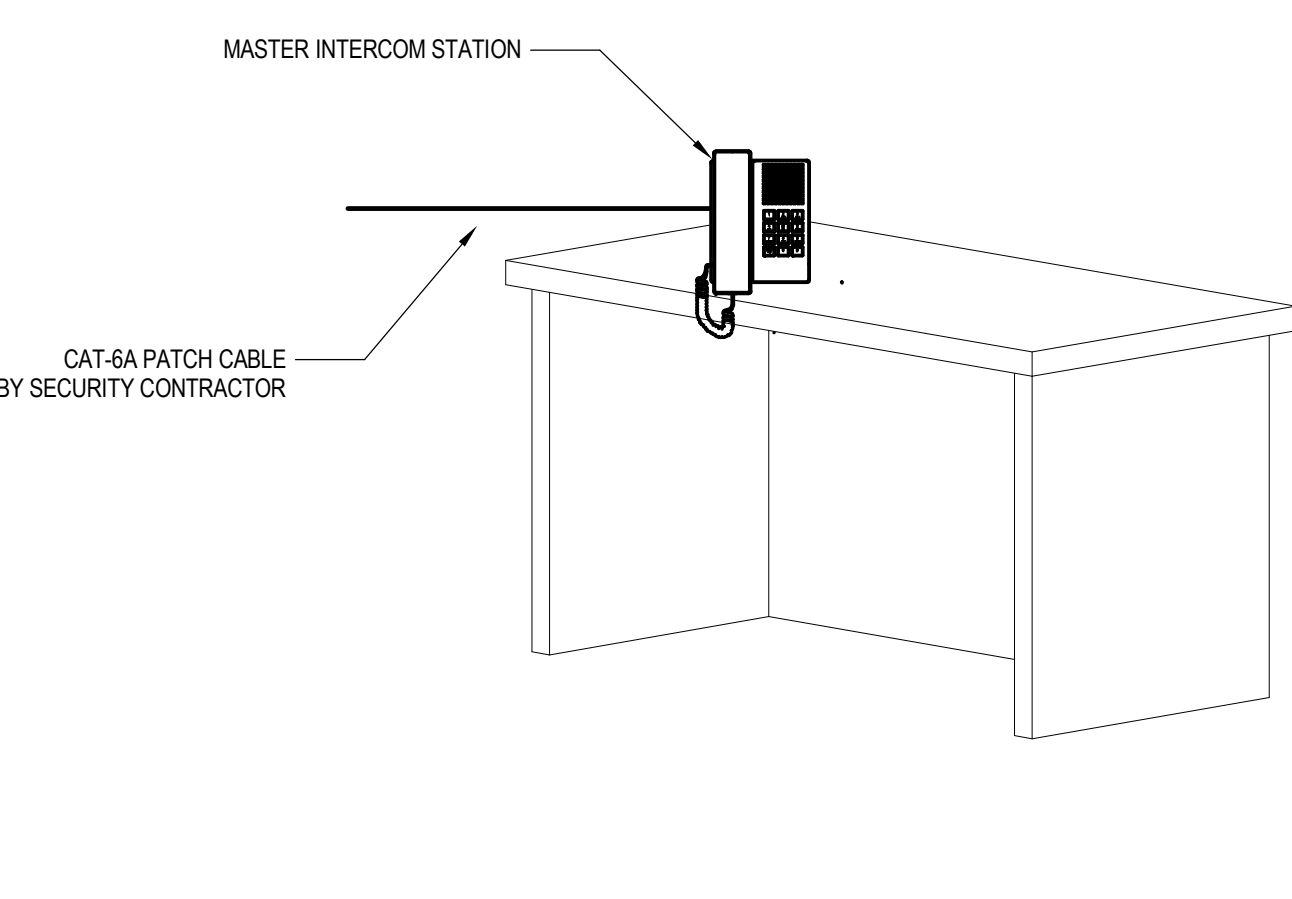

- NOTES:
1. DETAIL REPRESENTS TYPICAL SECURITY REQUIREMENTS
  2. FINAL MOUNTING LOCATIONS TO BE COORDINATED WITH ARCHITECT'S INTERIOR
  3. SEE WIRING/BORING/CEILING PLANS FOR DEVICE LOCATIONS

**9** INTERCOM MASTER (IP) DESKTOP  
SCALE: NTS

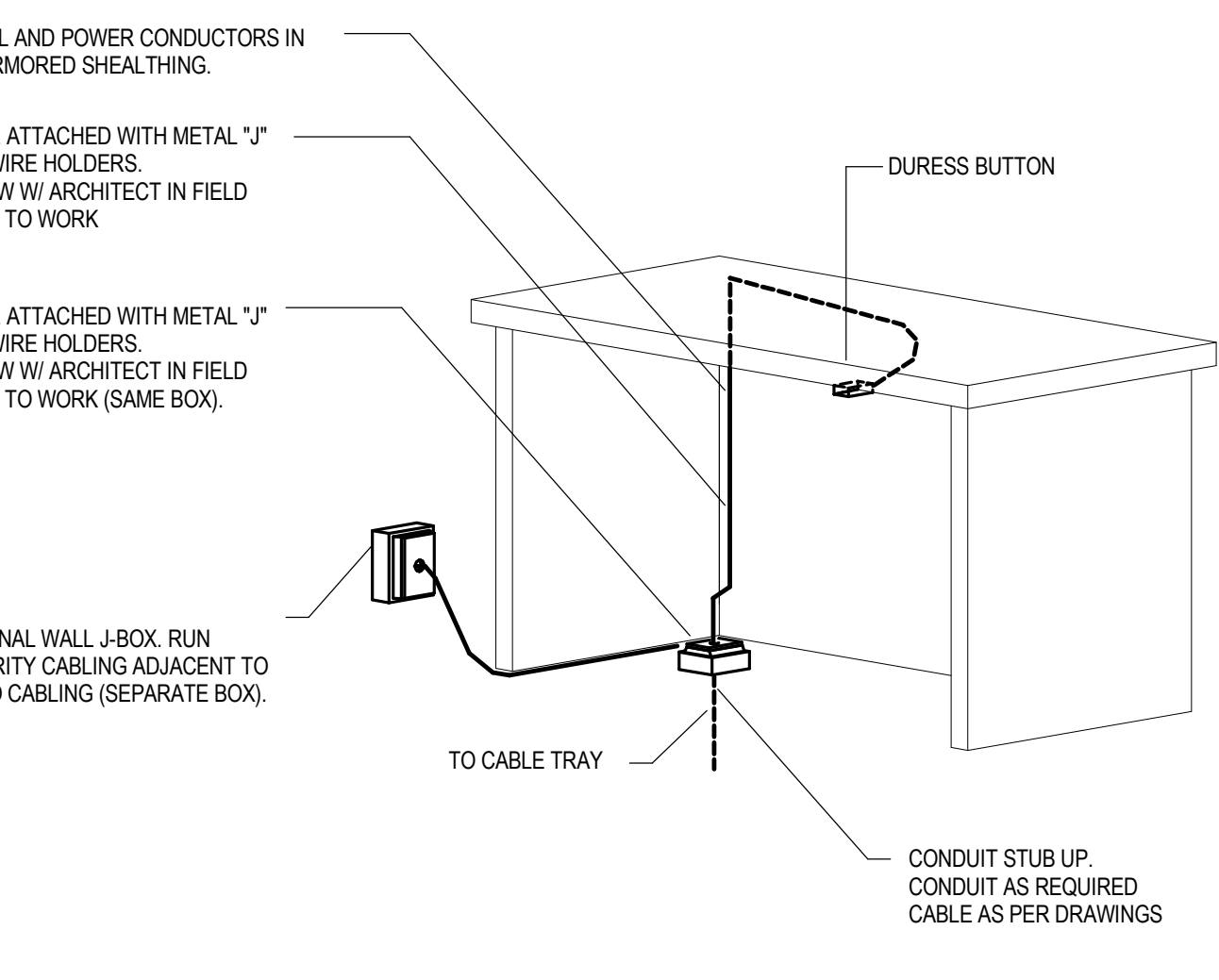

- NOTES:
1. DETAIL REPRESENTS TYPICAL SECURITY REQUIREMENTS
  2. FINAL MOUNTING LOCATIONS TO BE COORDINATED WITH ARCHITECT'S INTERIOR
  3. SEE WIRING/BORING/CEILING PLANS FOR DEVICE LOCATIONS

**8** DURESS/PANIC BUTTON UNDER DESK MOUNT  
SCALE: NTS

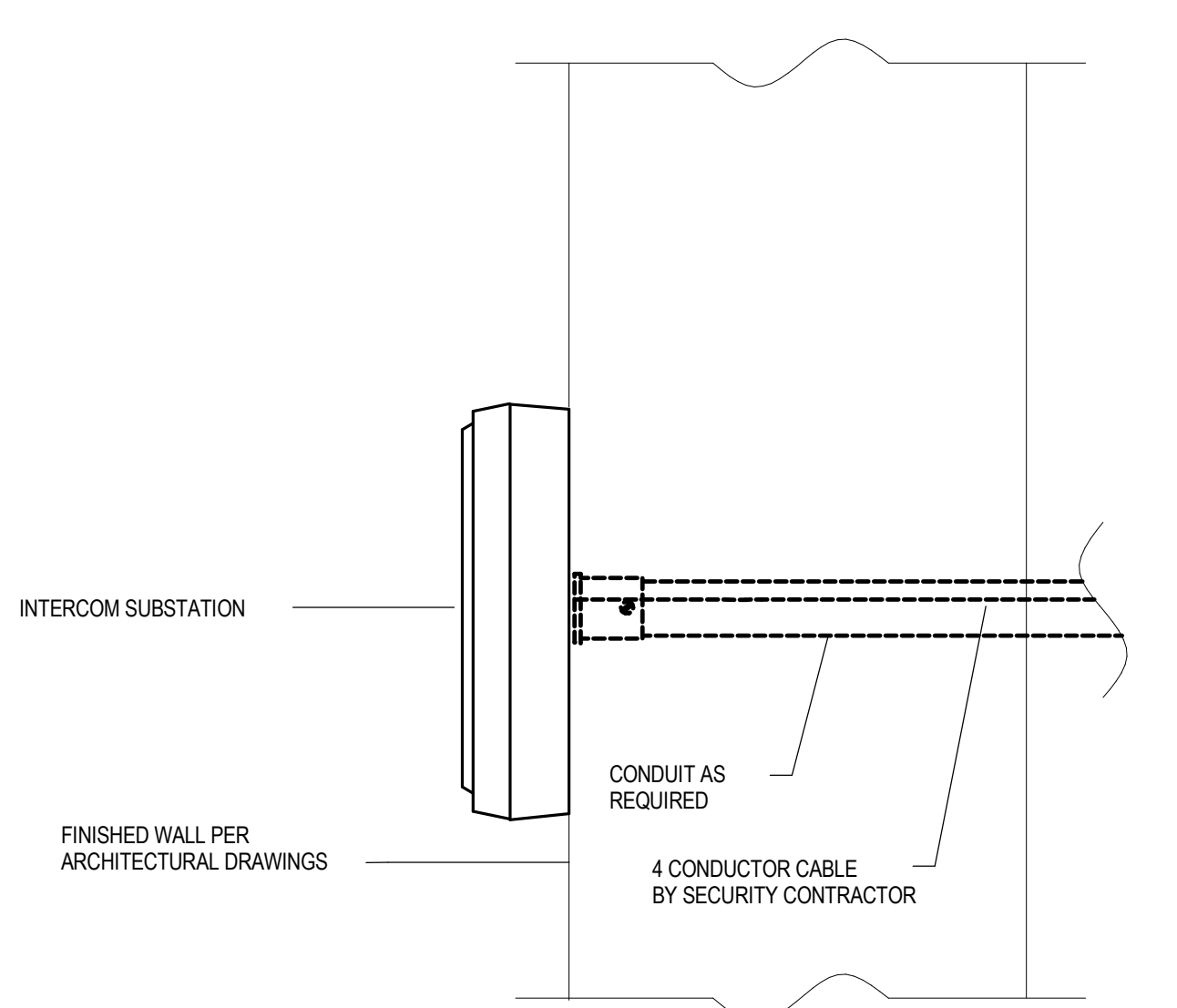

- NOTES:
1. DETAIL REPRESENTS TYPICAL SECURITY REQUIREMENTS
  2. FINAL MOUNTING LOCATIONS TO BE COORDINATED WITH ARCHITECT'S INTERIOR
  3. SEE WIRING/BORING/CEILING PLANS FOR DEVICE LOCATIONS

**11** INT/EXT WALL MOUNT INTERCOM SUBSTATION (2/4 WIRE)  
SCALE: NTS