

NO.	ISSUE	DATE
Job Number	152181.000	
Drawn	REE	
Checked	BAIT	
Approved	JHT	

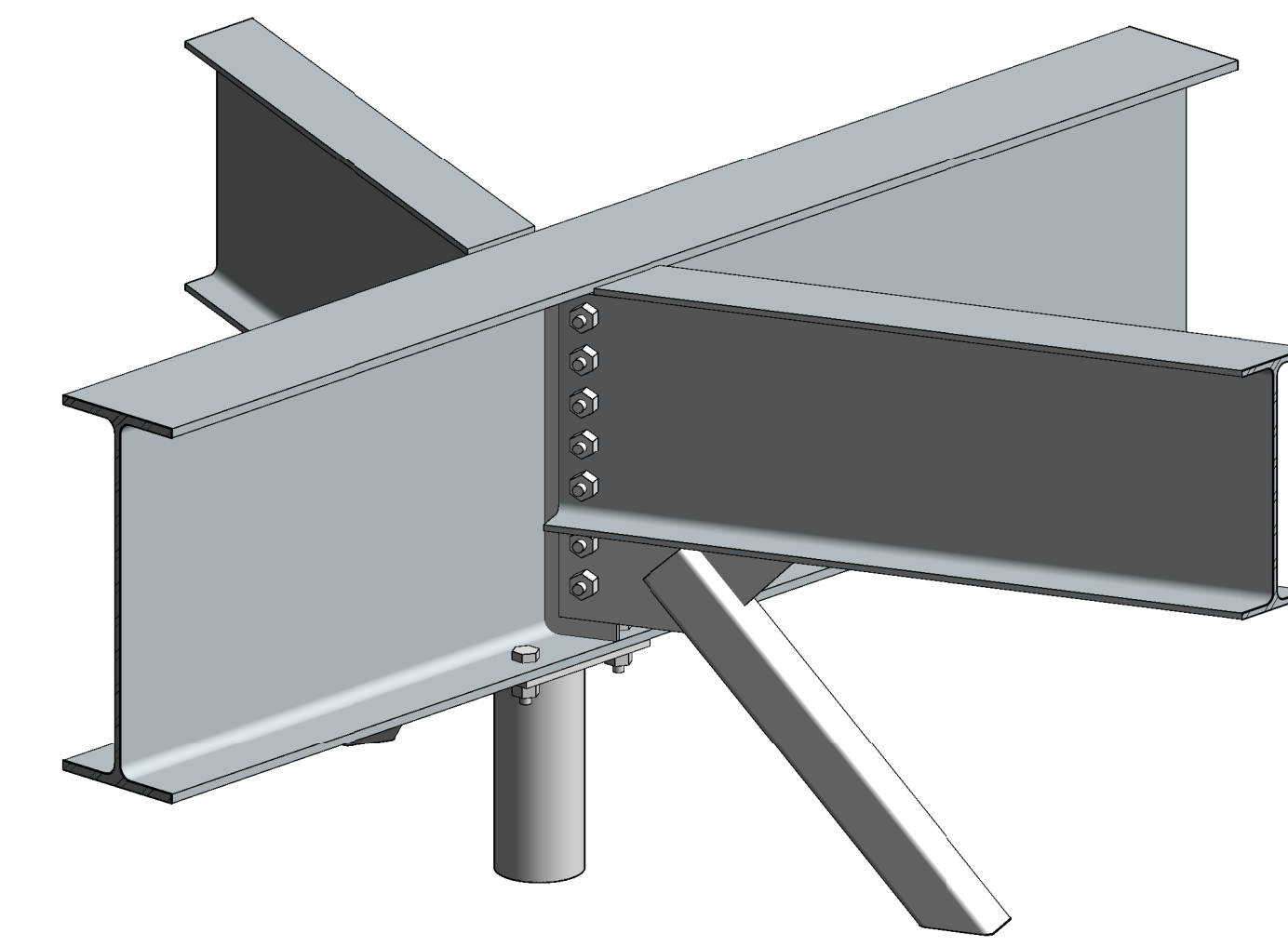

7 HELIPAD BEAM OVER POST W/BRACES

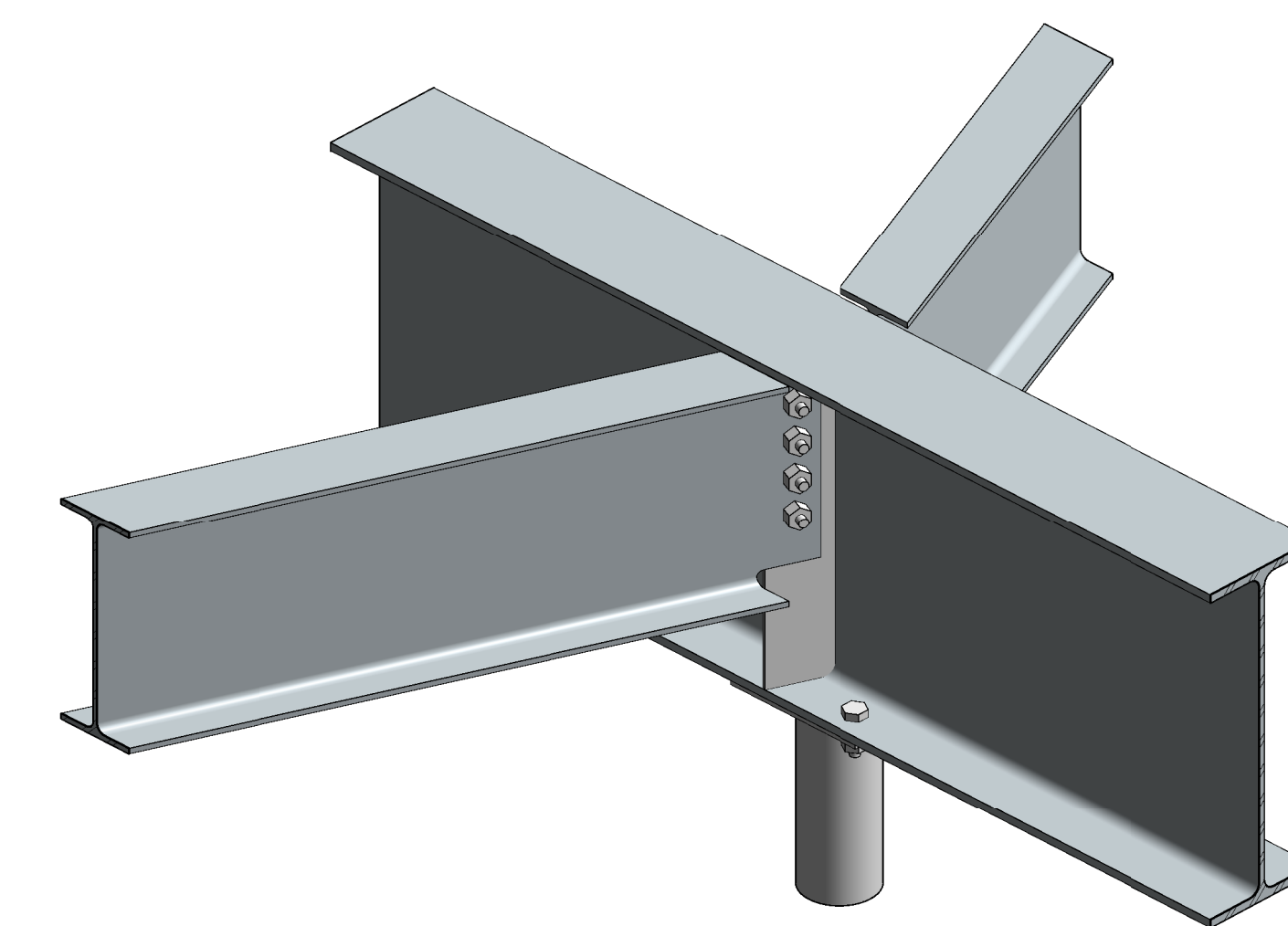

4 HELIPAD BEAM OVER POST

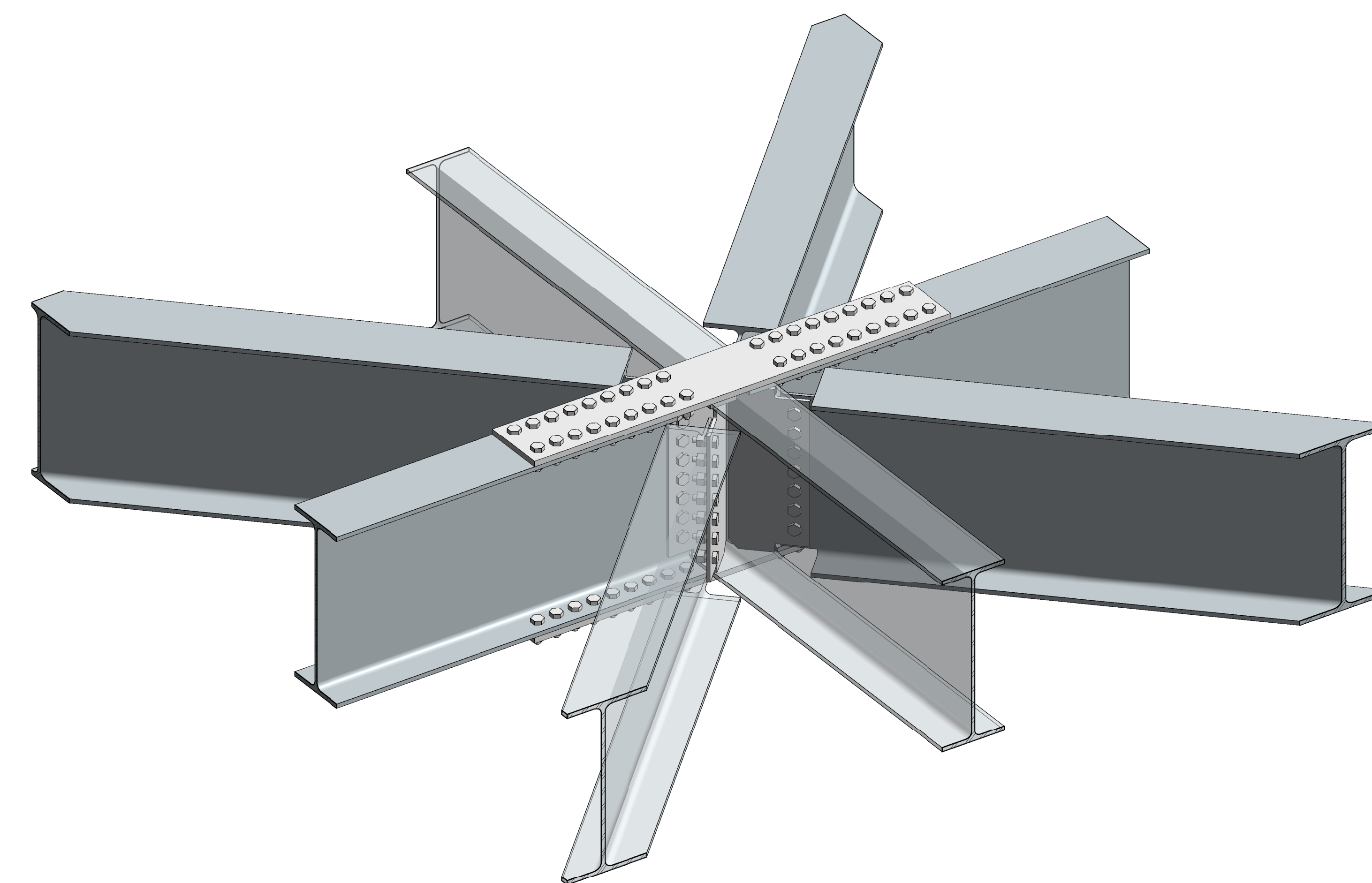

1 HELIPAD CENTER CONNECTION

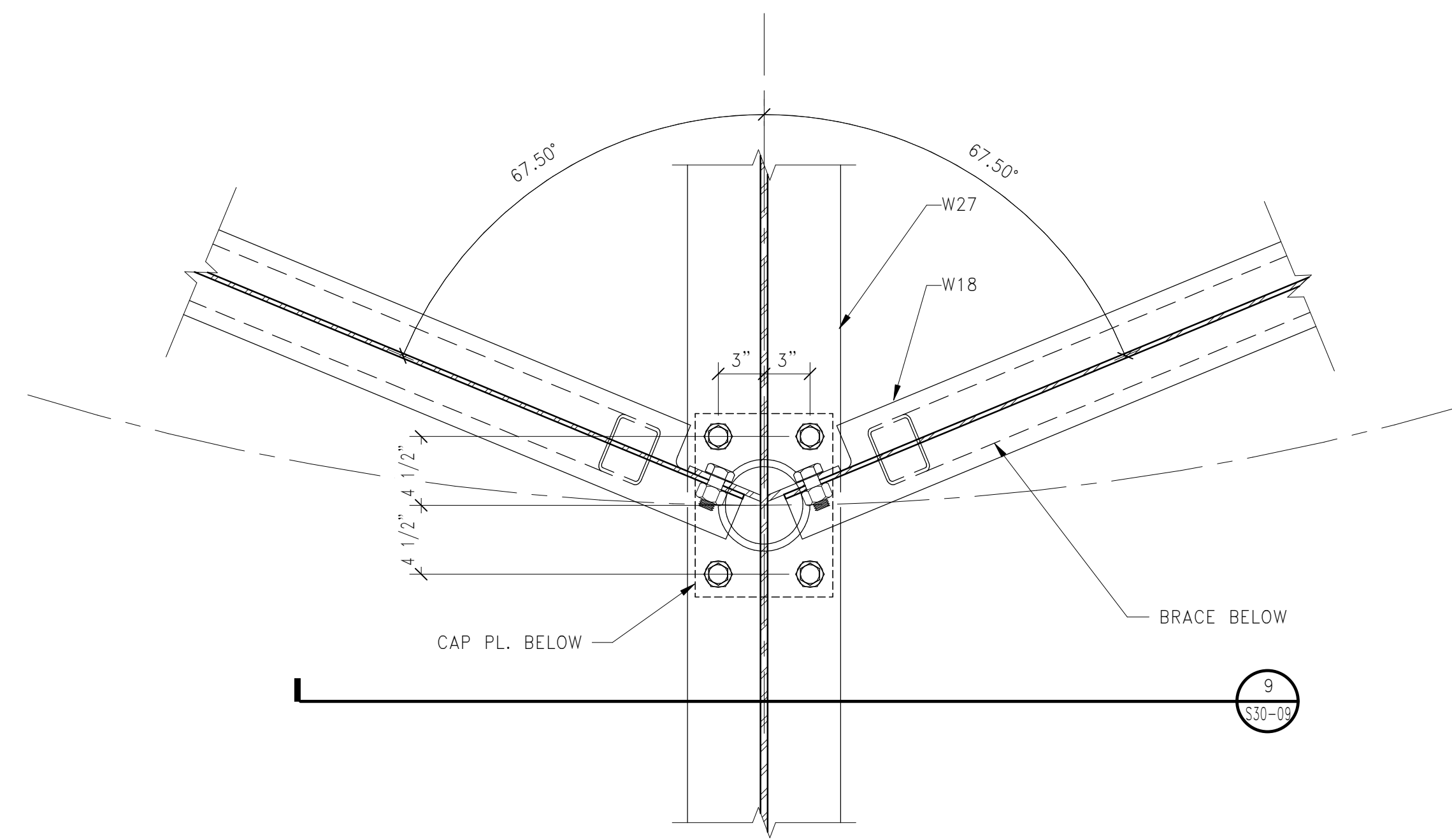

8 HELIPAD BEAM OVER COLUMN PLAN DETAIL W/BRACES

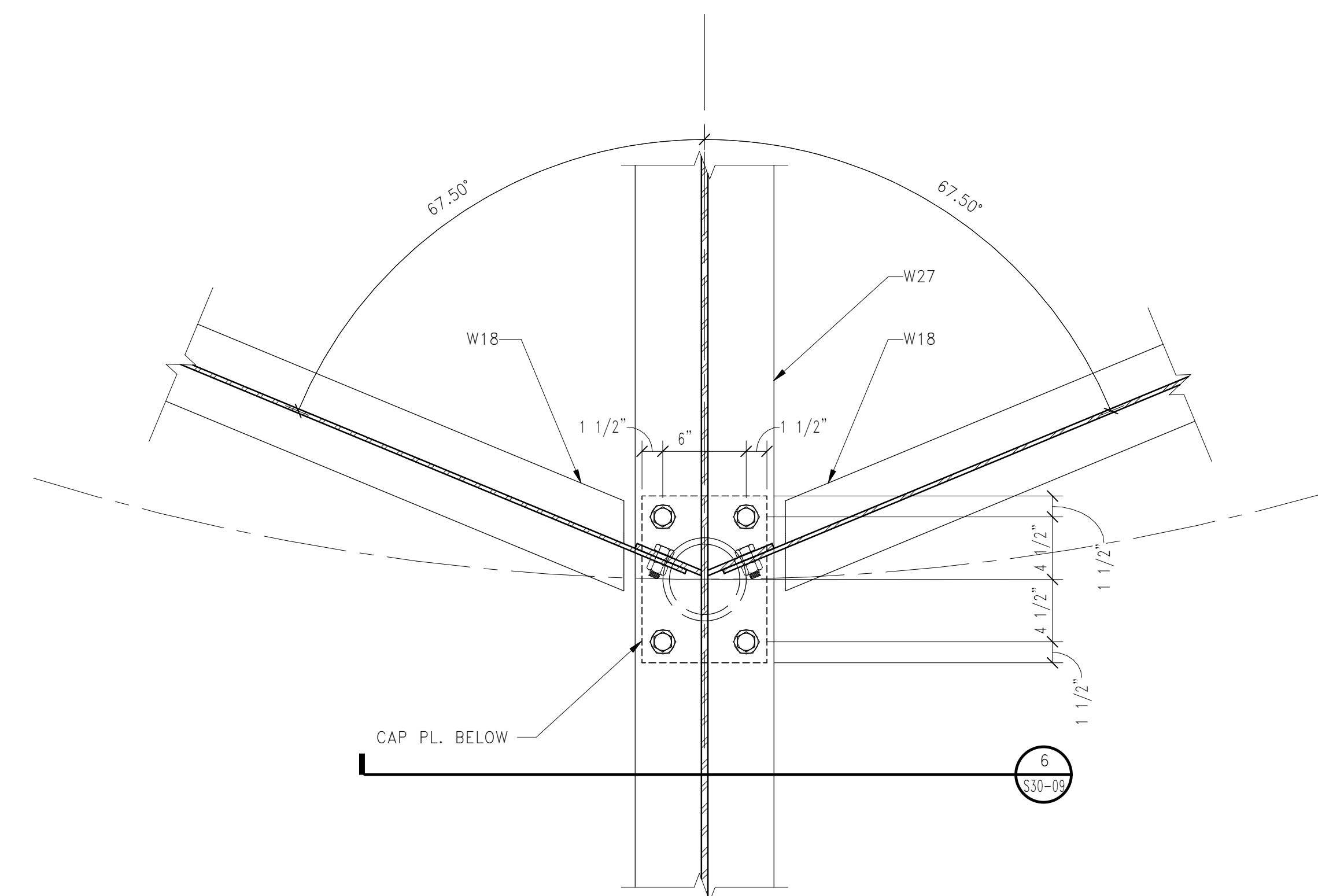

5 HELIPAD BEAM OVER COLUMN PLAN DETAIL

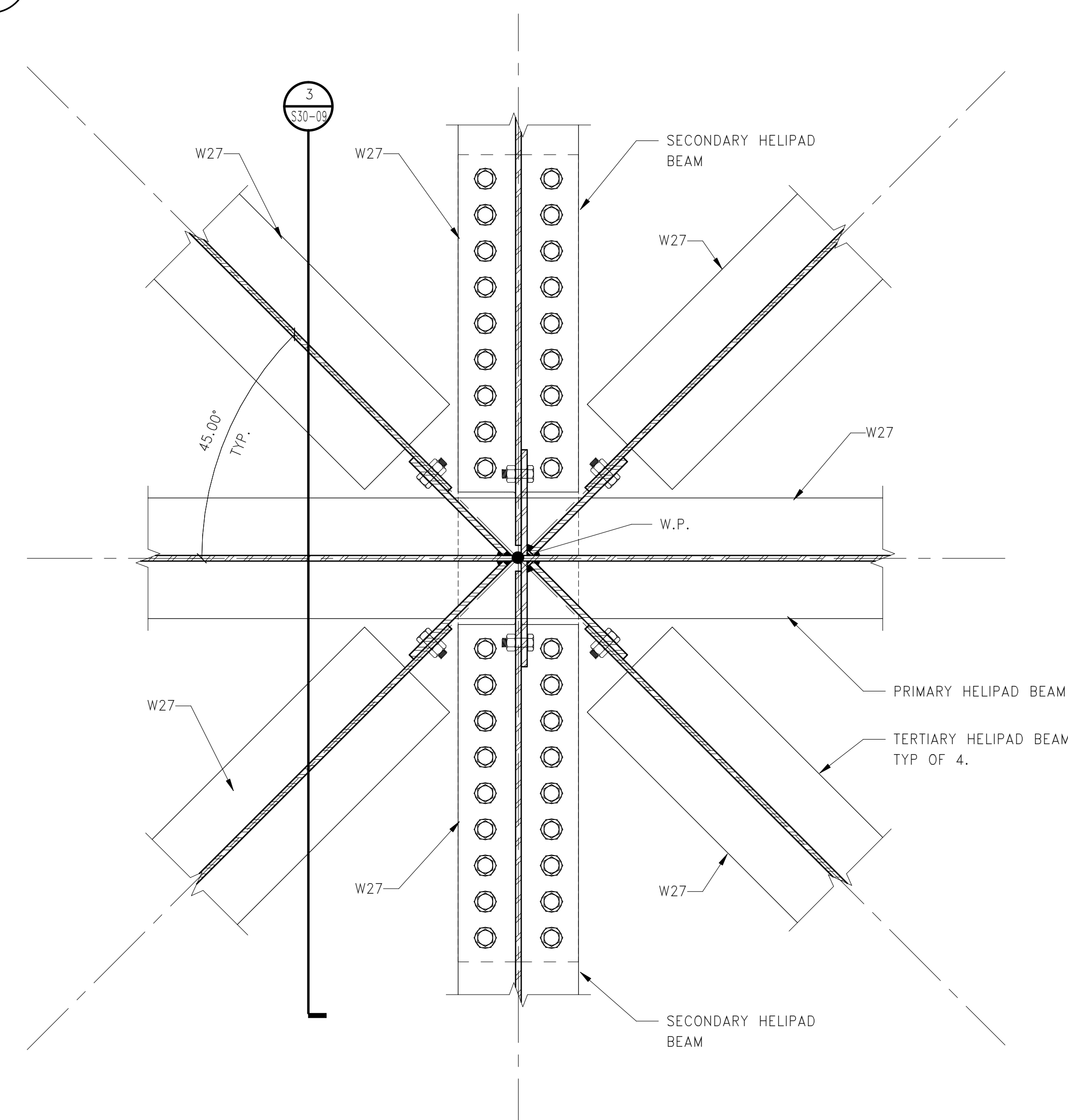

2 HELIPAD CENTER CONNECTION PLAN DETAIL

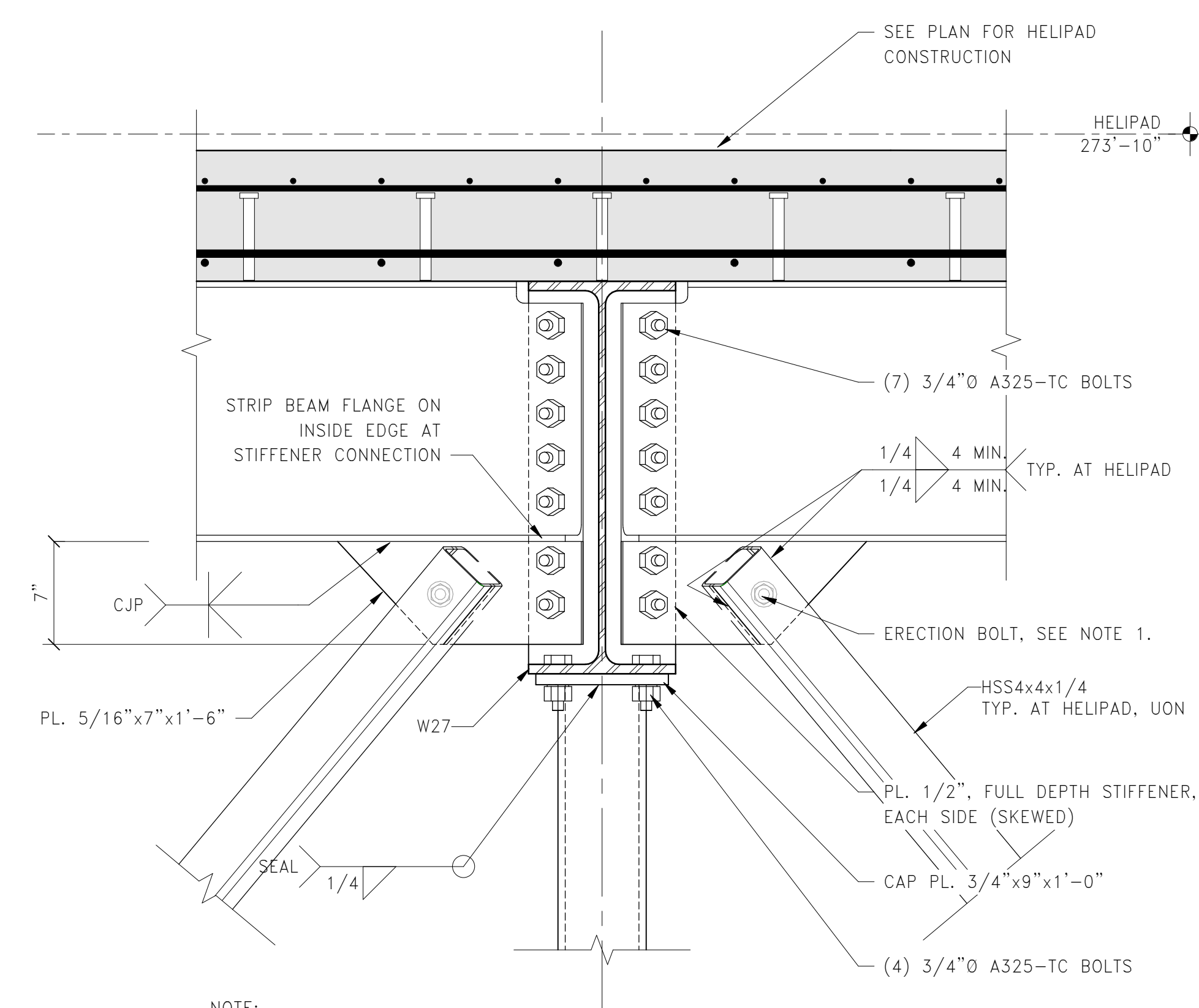

9 SECTION: HELIPAD BEAM OVER COLUMN W/BRACES

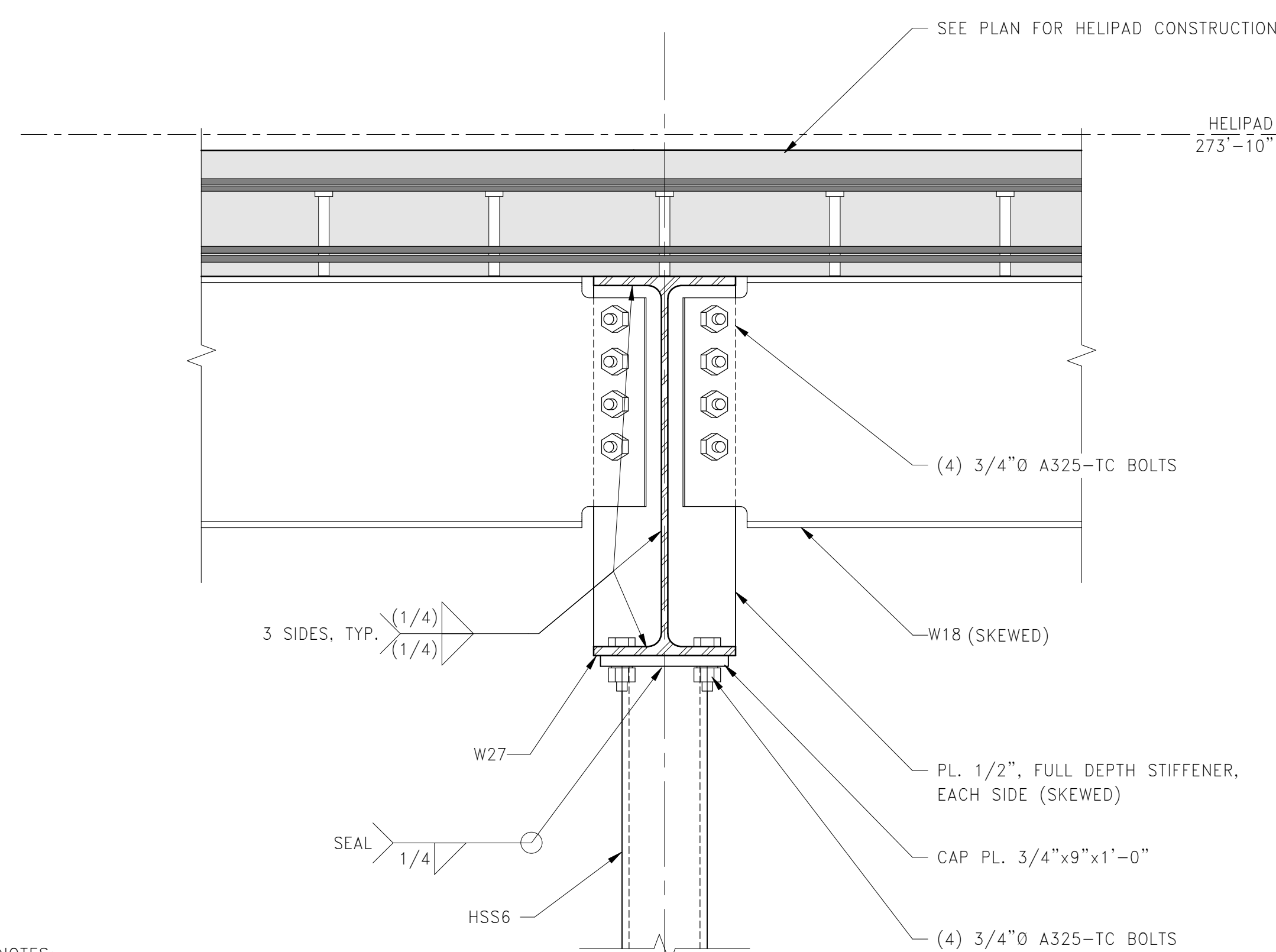

6 SECTION: HELIPAD BEAM OVER COLUMN

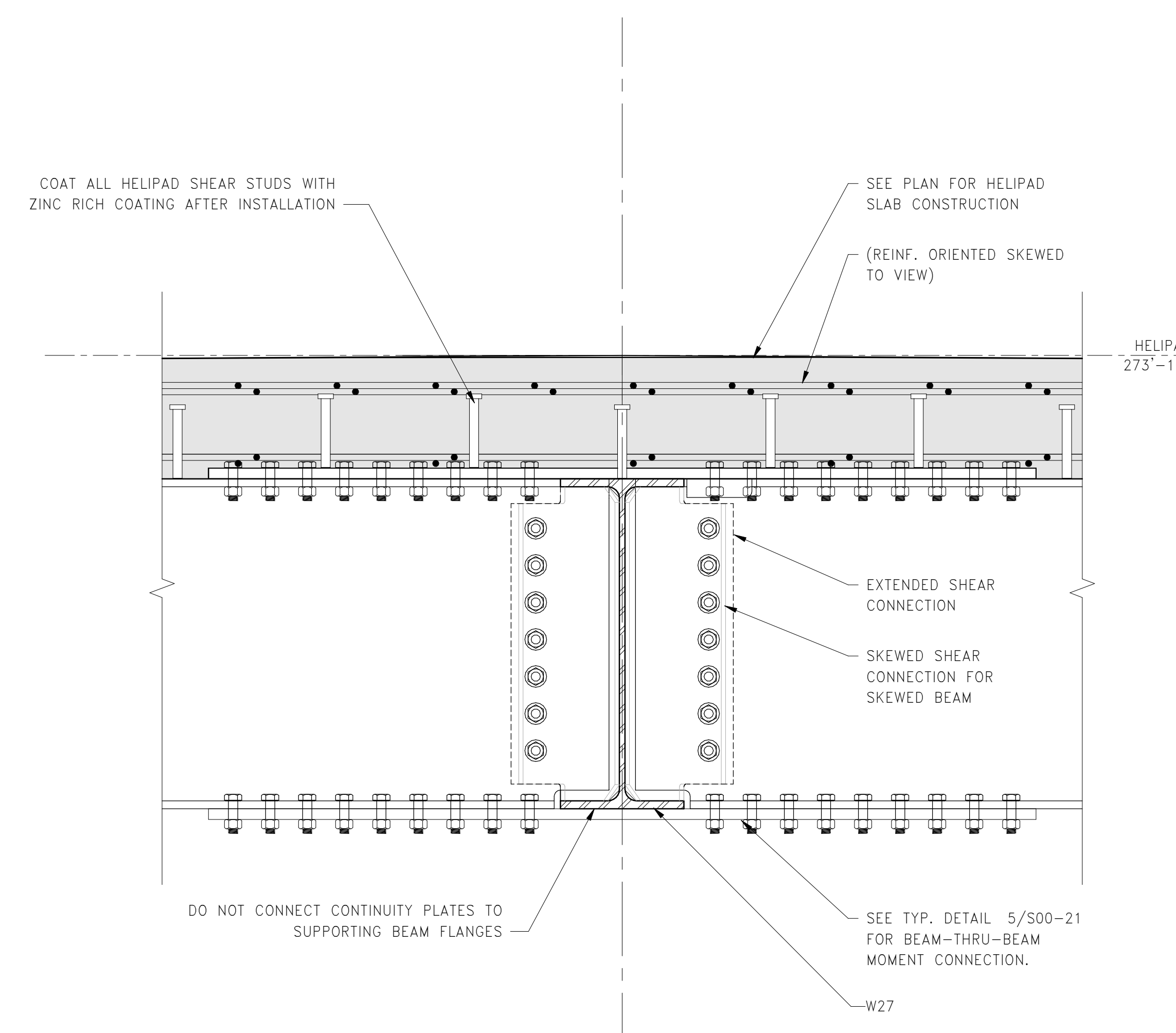

3 SECTION: HELIPAD CENTER BEAM MOMENT CONNECTION