

CONSTRUCTION DOCUMENTS
 JANUARY 28, 2018

1	ADDENDUM 1	03.22.18
NO.	ISSUE	DATE
Job Number	152181.000	
Drawn	REE	
Checked	BMJ	
Approved	JHT	

STEEL TYPICAL DETAILS

SHEET NUMBER

S00-24

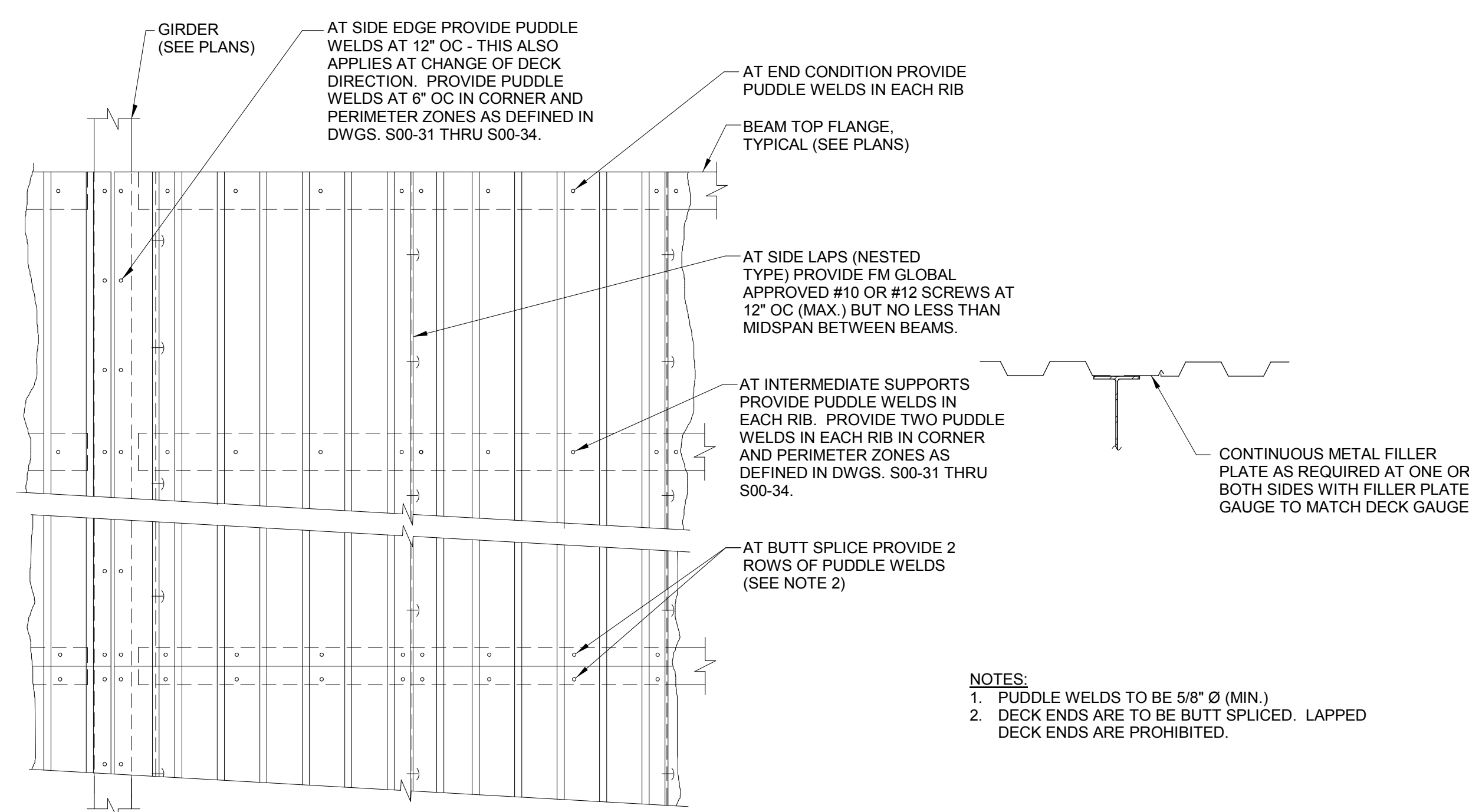

10 FASTENING PATTERN FOR 3" METAL ROOF DECK
 NOT TO SCALE

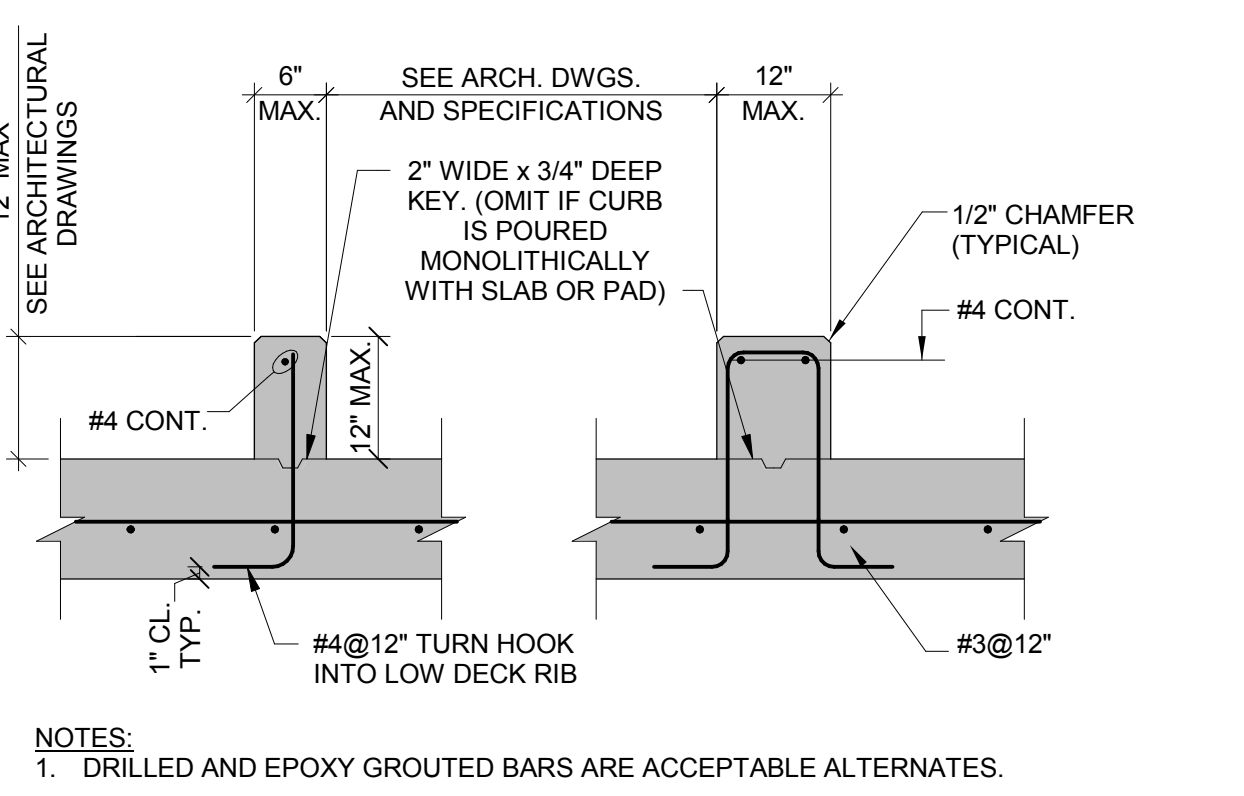

7 CONCRETE CURB ON COMPOSITE SLAB
 NOT TO SCALE

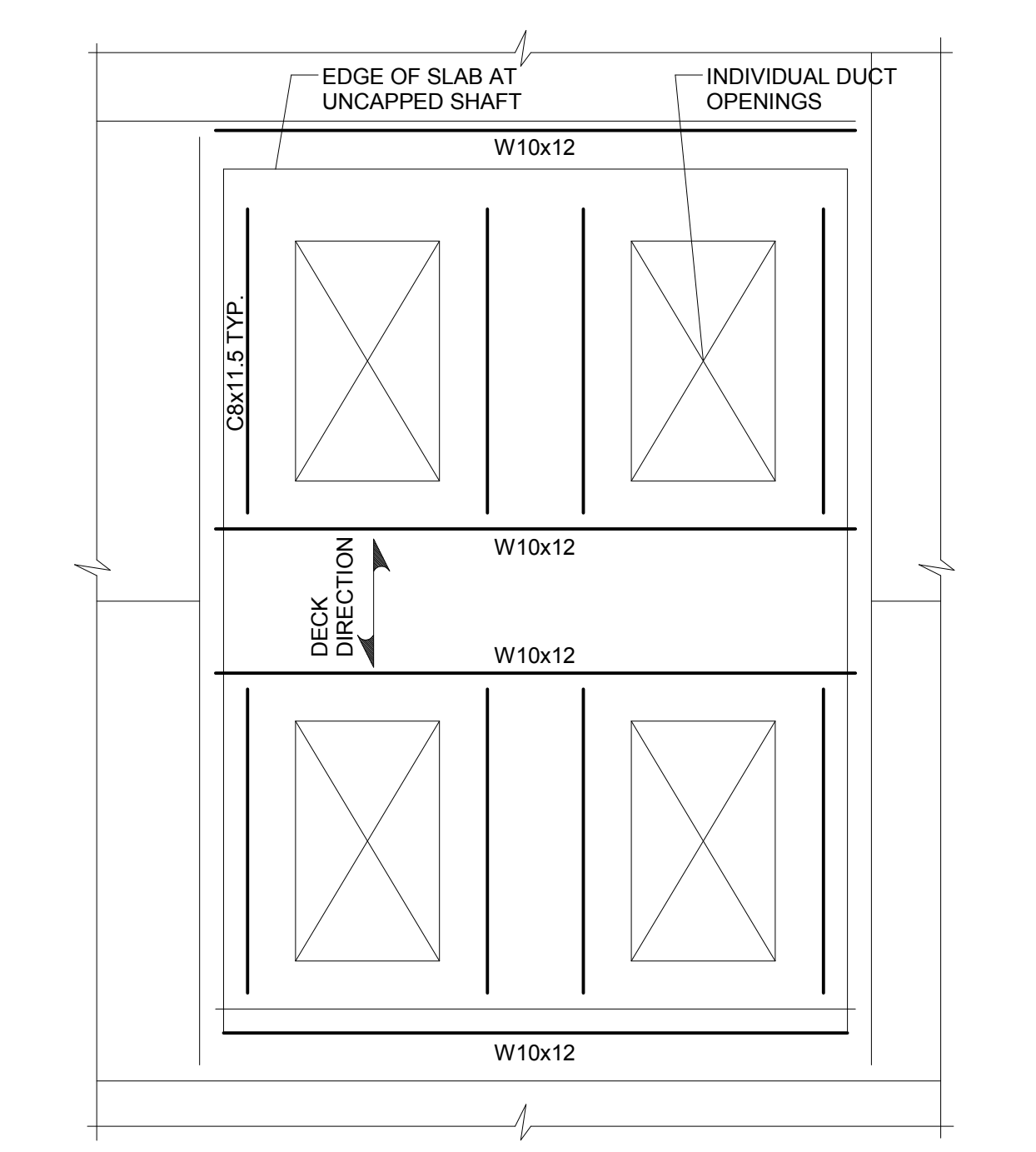

3 CAPPED SHAFT
 NOT TO SCALE

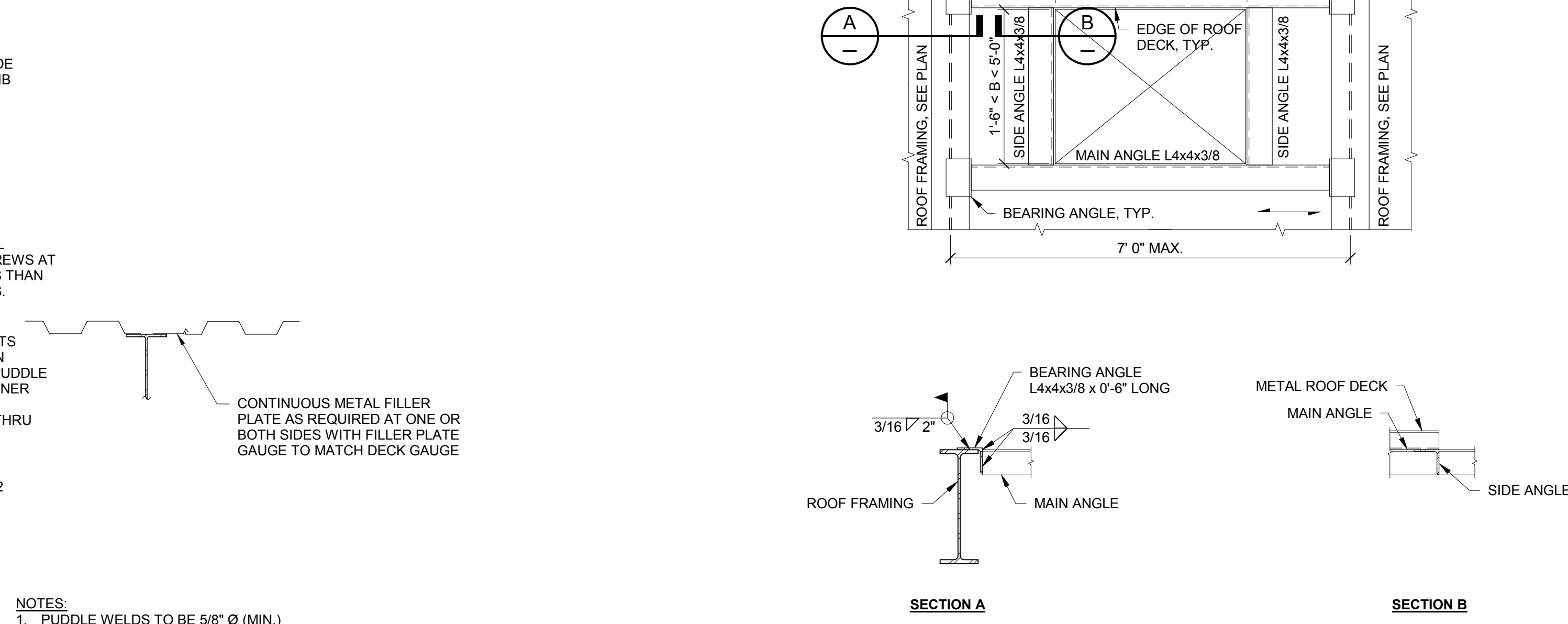

9 NON-COMPOSITE DECK OPENING FRAMING DETAIL
 3/4" = 1'-0"

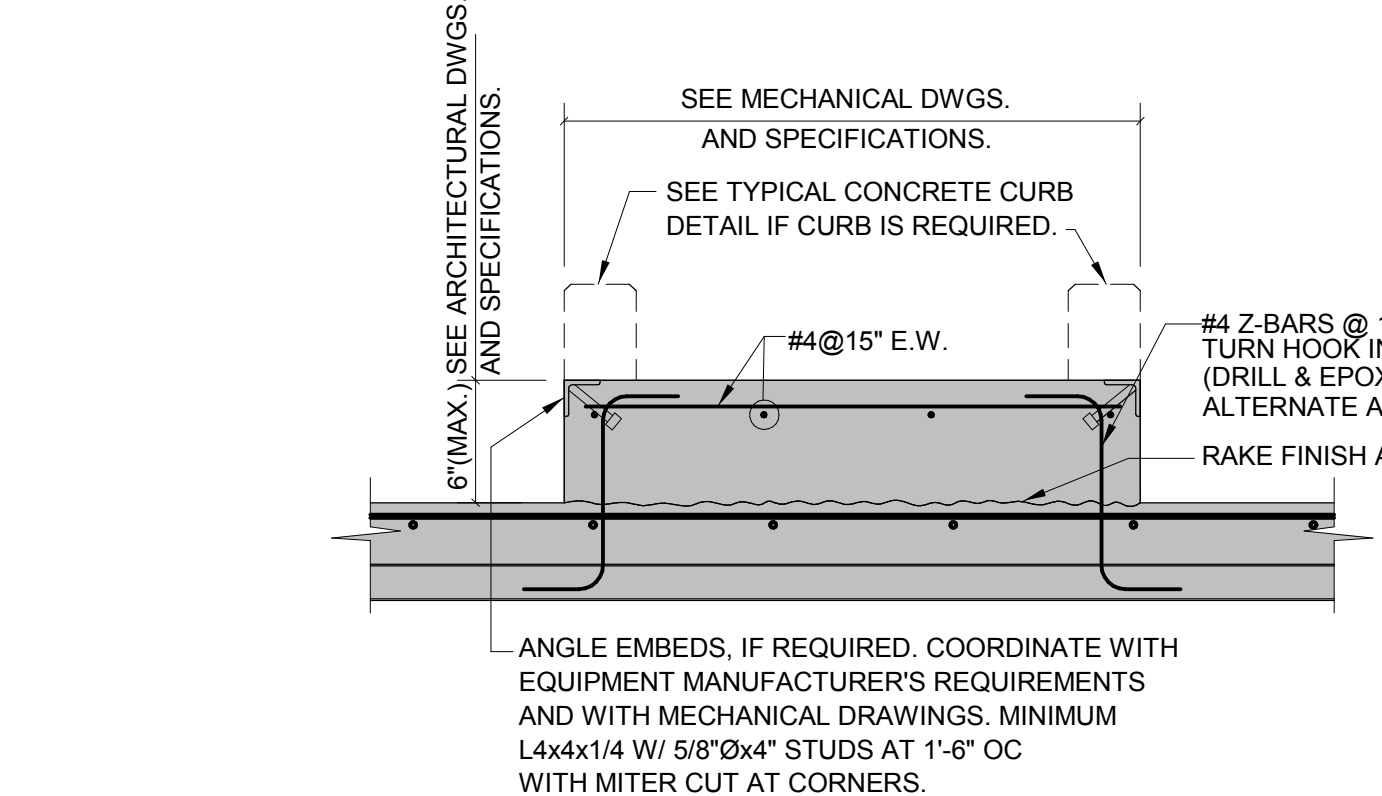

6 HOUSEKEEPING PAD ON COMPOSITE SLAB DETAIL
 NOT TO SCALE

SEPARATION JOINT SCHEDULE

ANTICIPATED JOINT MODEL (NOTE 1)	"A" (MIN)	"B" (MIN)
SGR-600	3/4"	3.5"
SGR-700	3/4"	4.0"
SGR-1000	3/4"	4.5"
GTR-300	5/8"	3.5"
SJPRF-400 W/FB	1 1/4"	3.0"

5 DETAIL AT FLOOR-TO-FLOOR SEPARATION JOINT
 NOT TO SCALE

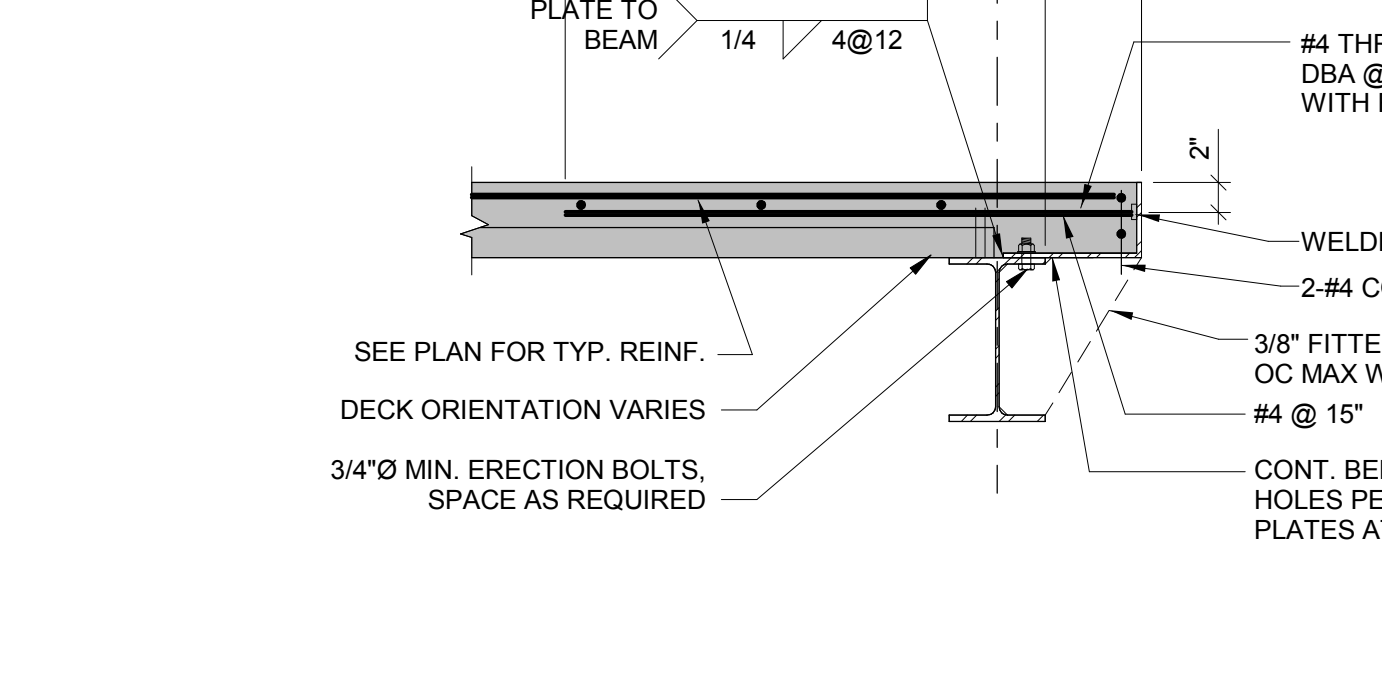

2 TYPICAL SLAB EDGE WHERE BENT PLATE IS INDICATED ON PLAN
 NOT TO SCALE

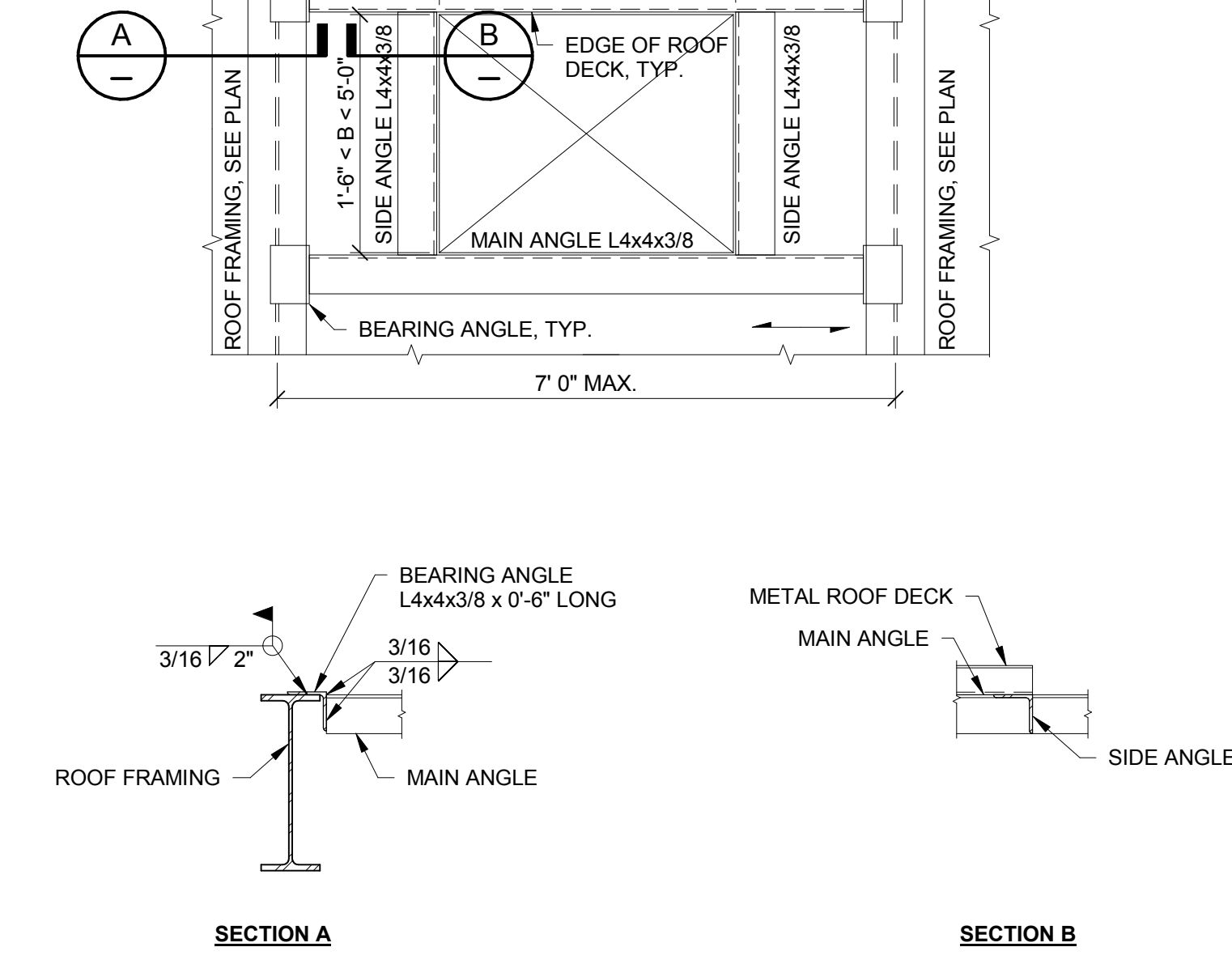

8 ROOF DECK OPENING REINFORCEMENT
 NOT TO SCALE

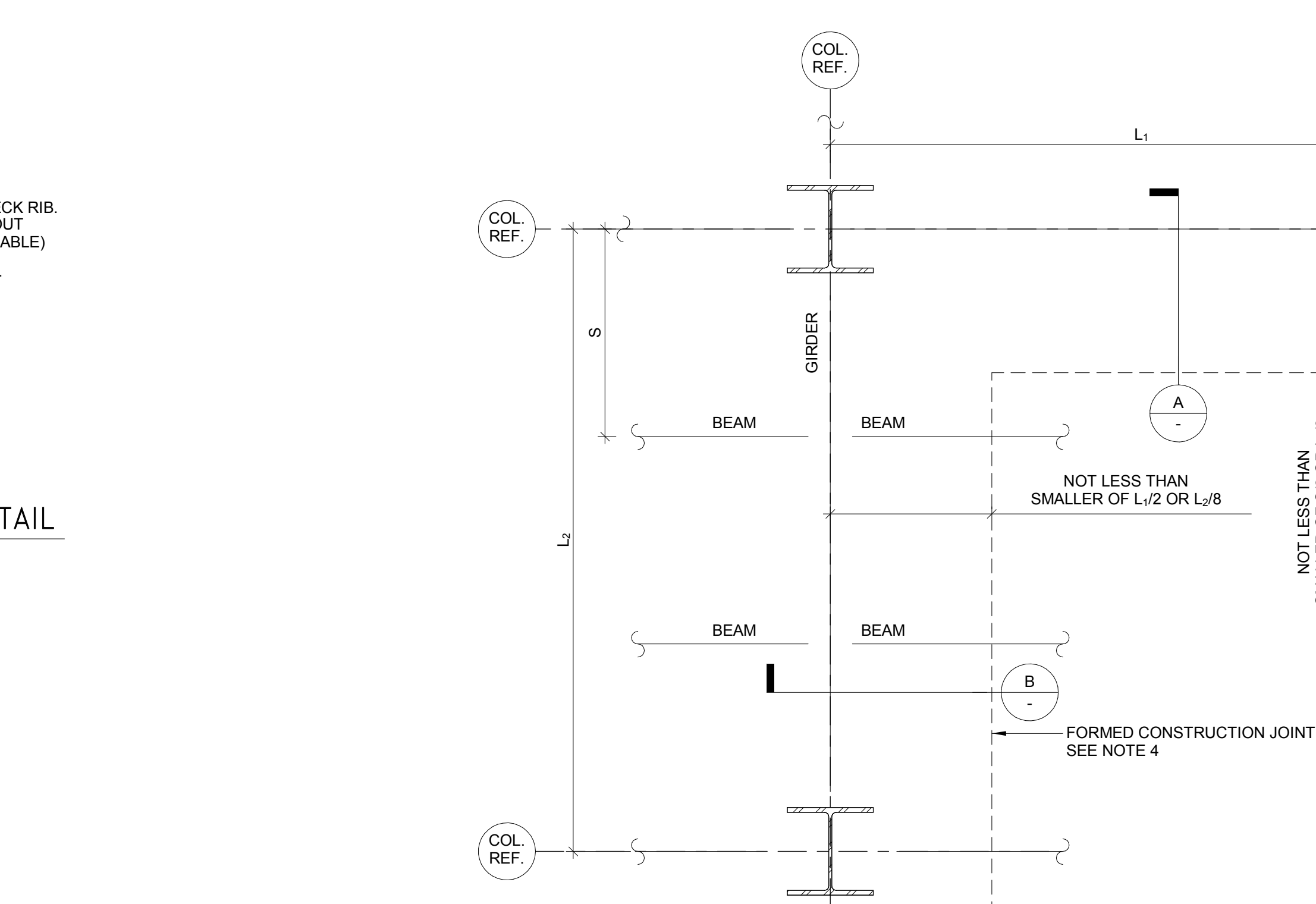

4 CONSTRUCTION JOINT LAYOUT FOR COMPOSITE SLABS
 NOT TO SCALE

MINIMUM BENT PLATE THICKNESS (IN.)

SLAB THICKNESS (INCHES)	OVERHANG (INCHES)									
	10	11	12	13	14	15	16	17	18	
6.25	3/16	3/16	3/16	1/4	1/4	1/4	5/16	5/16	5/16	

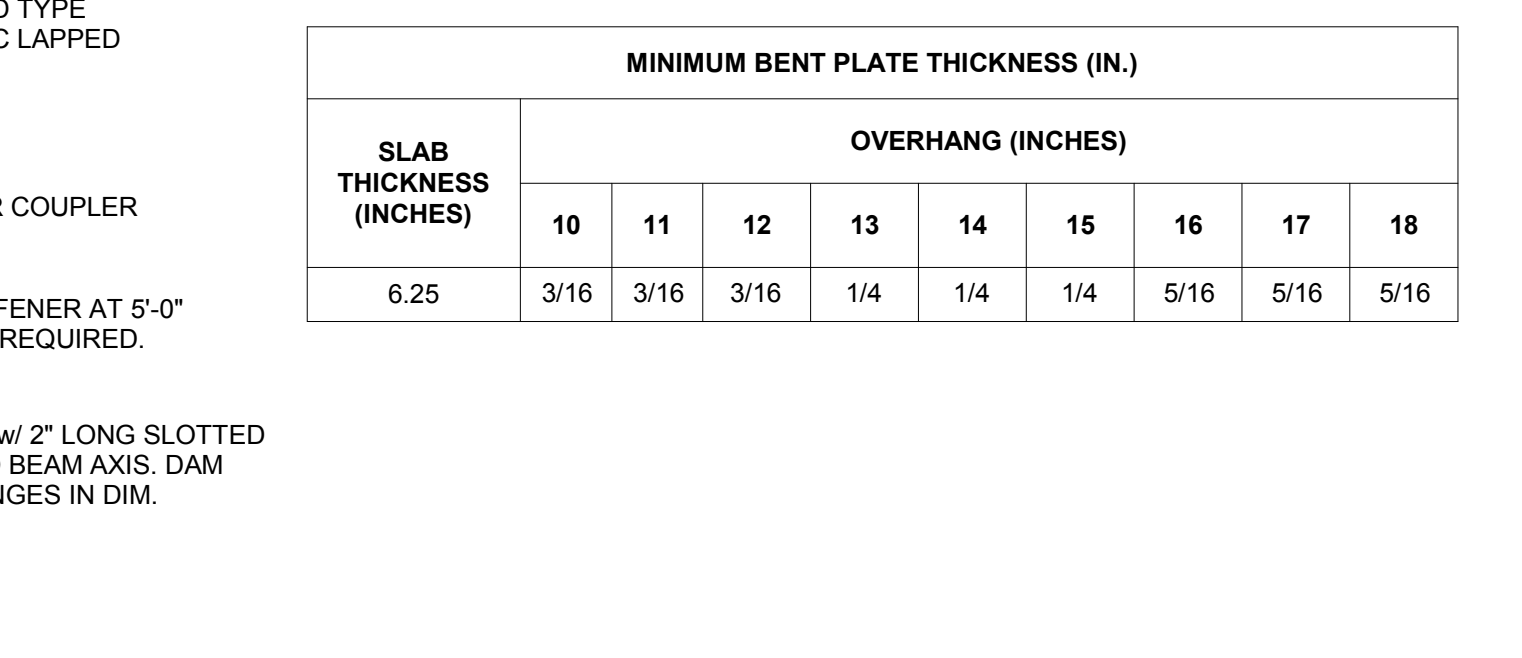

1 COMPOSITE DECK SLAB EDGE DETAIL WHERE BENT PLATE IS NOT INDICATED ON PLAN
 NOT TO SCALE

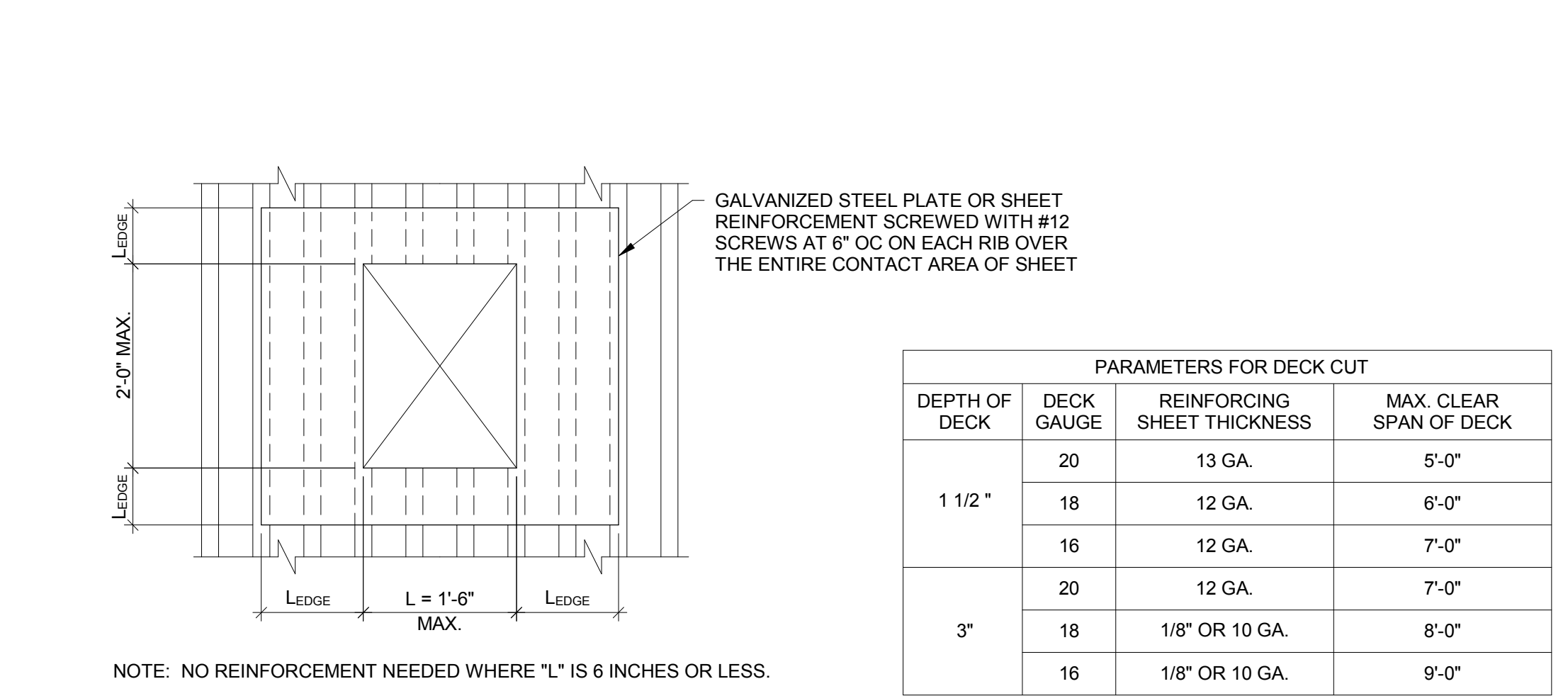

FOR OPENING TO 1'-6" PERPENDICULAR TO DECK

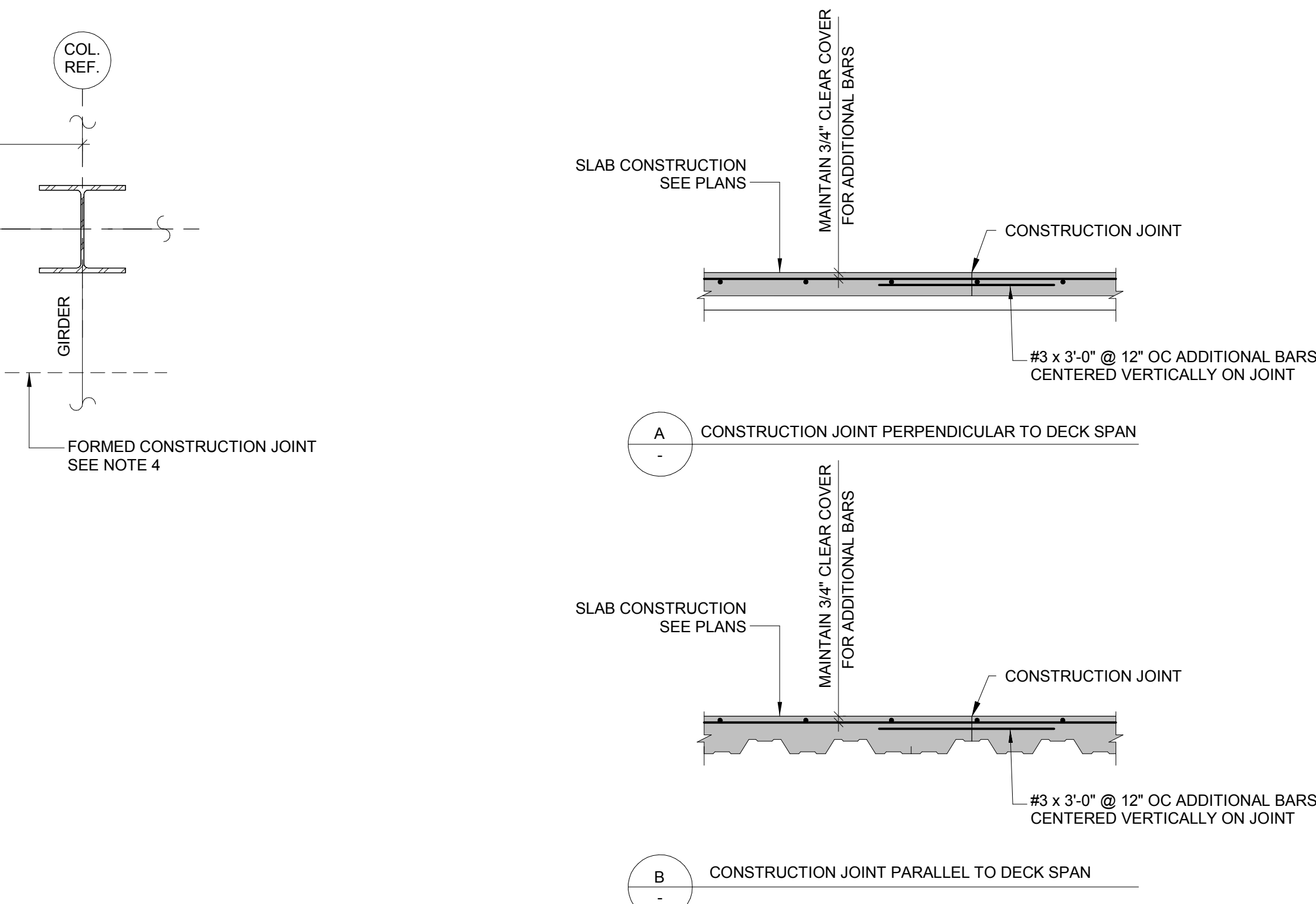

KEY PLANS
 PROJECT KEY PLAN
 EAST TOWER
 RICHARDS BUILDING
 TRUE NORTH

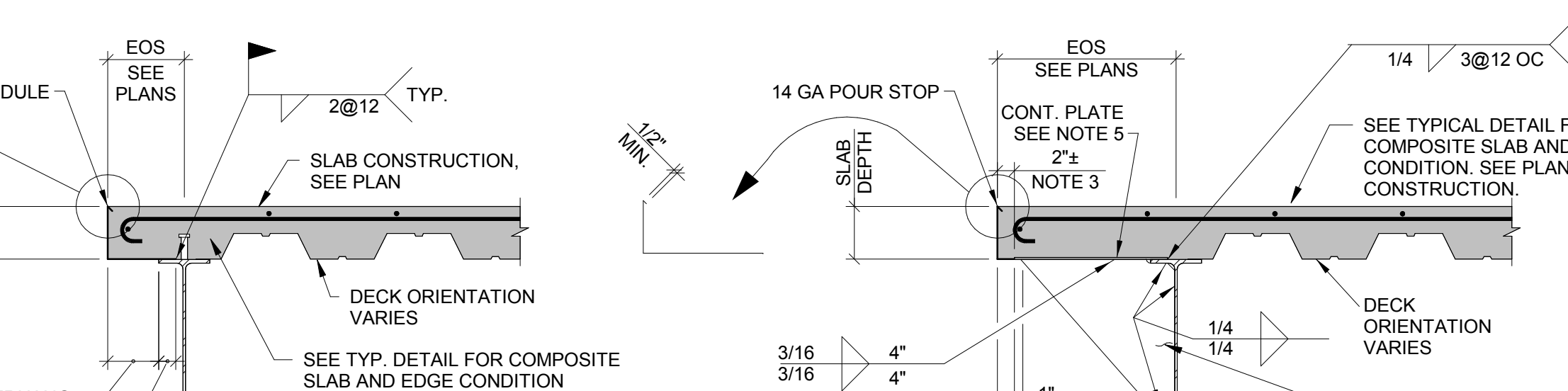

MINIMUM POUR STOP GAUGE

SLAB DEPTH (INCHES)	OVERHANG (INCHES)									
	0	1	2	3	4	5	6	7	8	9
6.25	10	10	14	14	12	12	12	12	10	10
7.5	16	14	14	12	12	12	10	10	10	NOTE 6

1 COMPOSITE DECK SLAB EDGE DETAIL WHERE BENT PLATE IS NOT INDICATED ON PLAN
 NOT TO SCALE