

NO.	ISSUE	DATE
Job Number	152181.000	
Drawn	TEAM	
Checked		
Approved	JK	

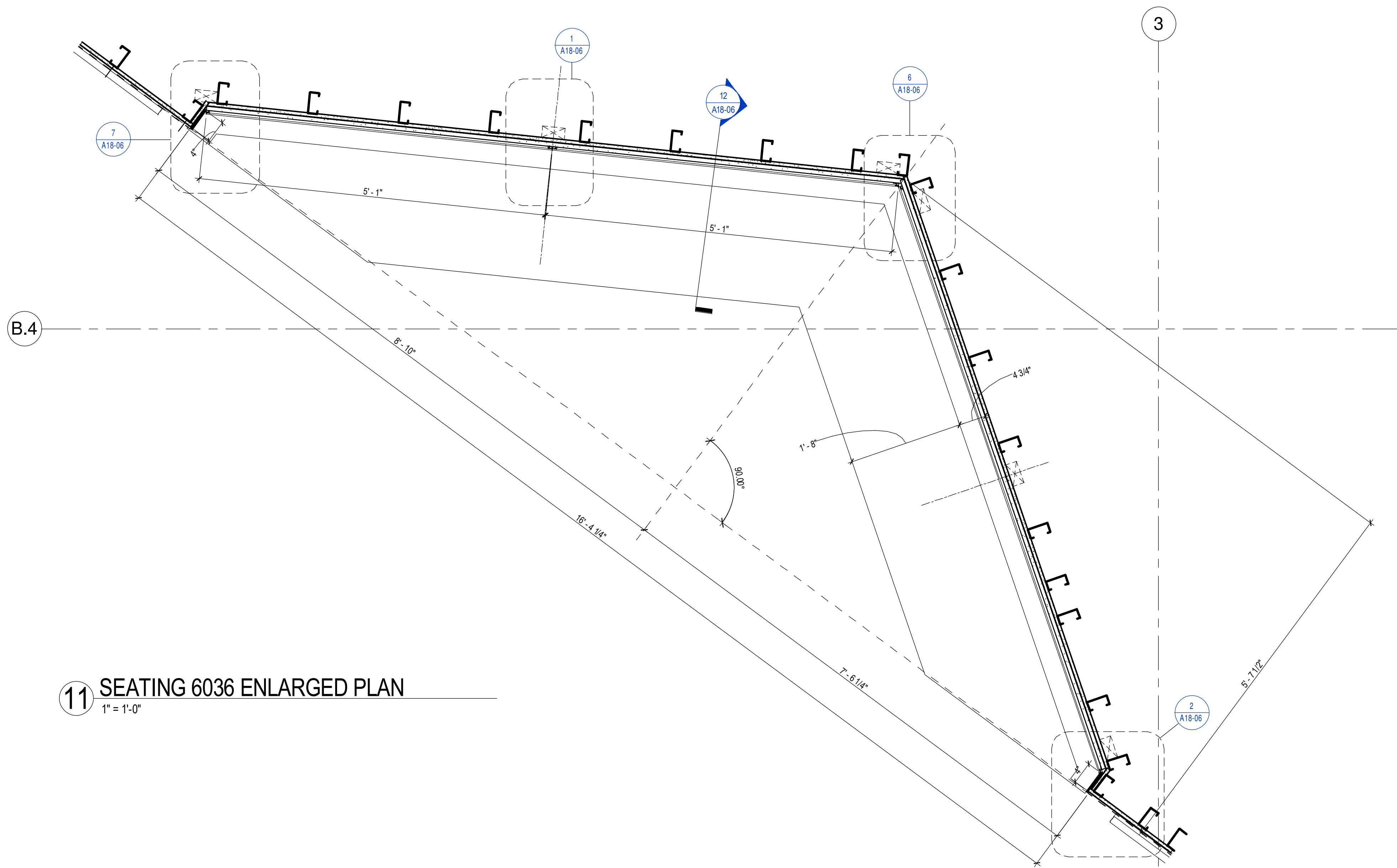

11 SEATING 6036 ENLARGED PLAN
1" = 1'-0"

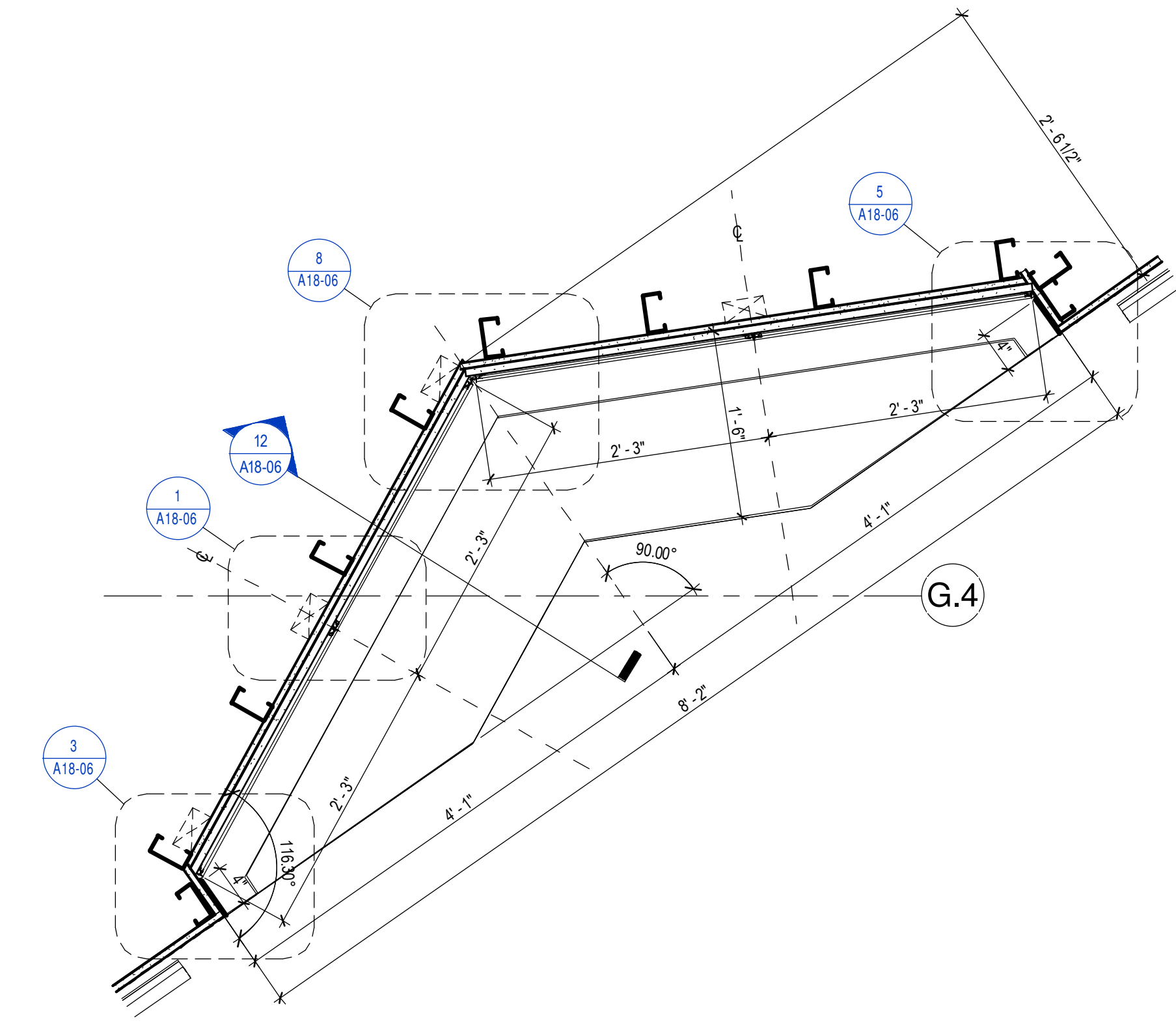

4 SEATING 6076 ENLARGED PLAN
1" = 1'-0"

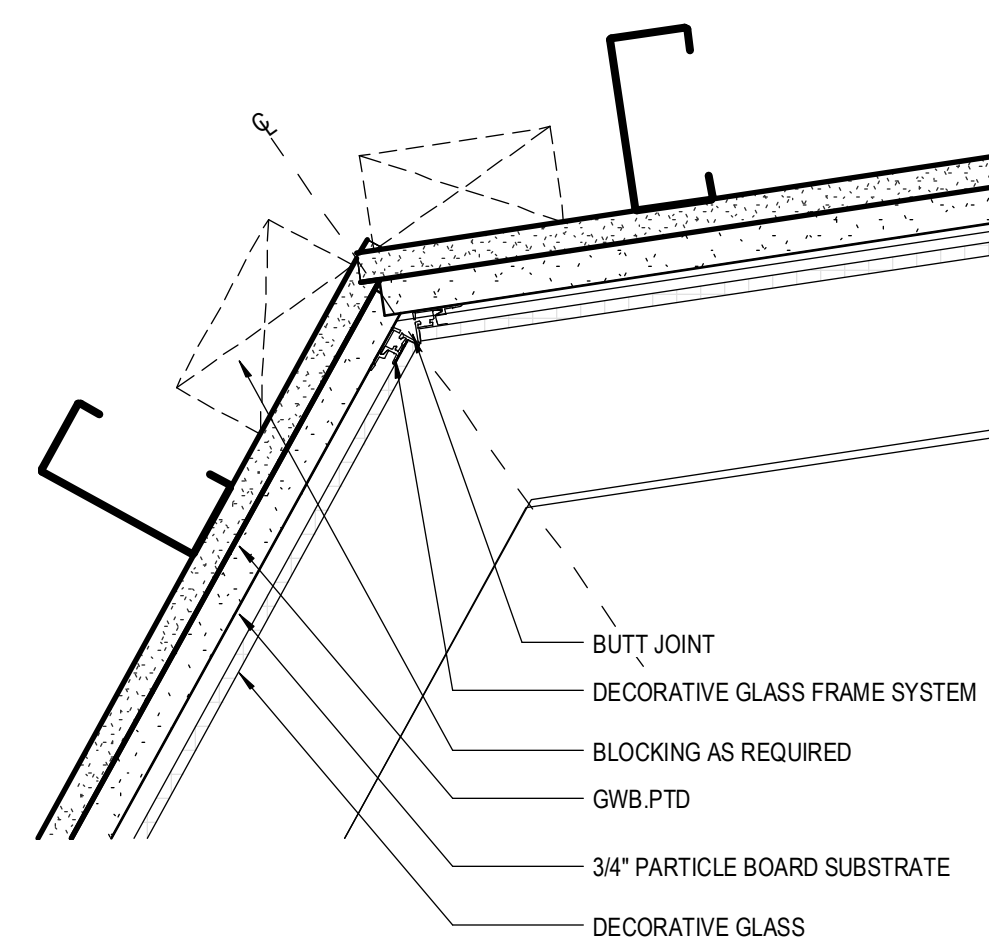

8 PLAN DETAIL MID CONER
3" = 1'-0"

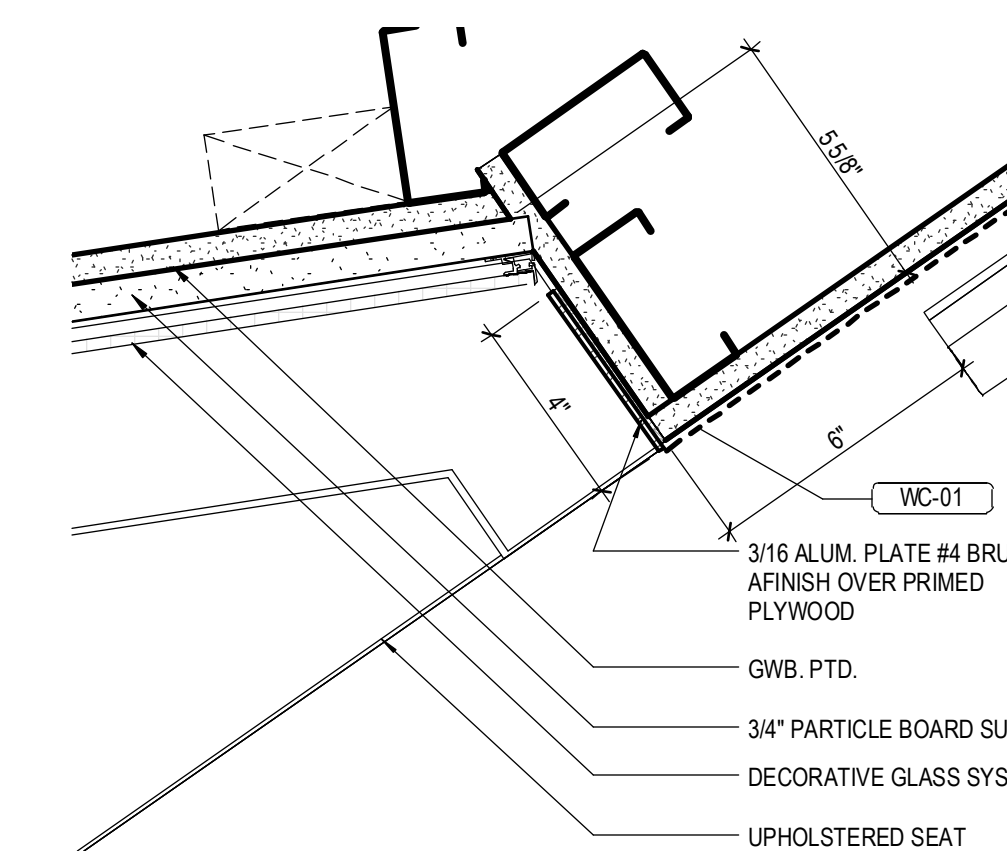

5 PLAN DETAIL- LEFT CONER
3" = 1'-0"

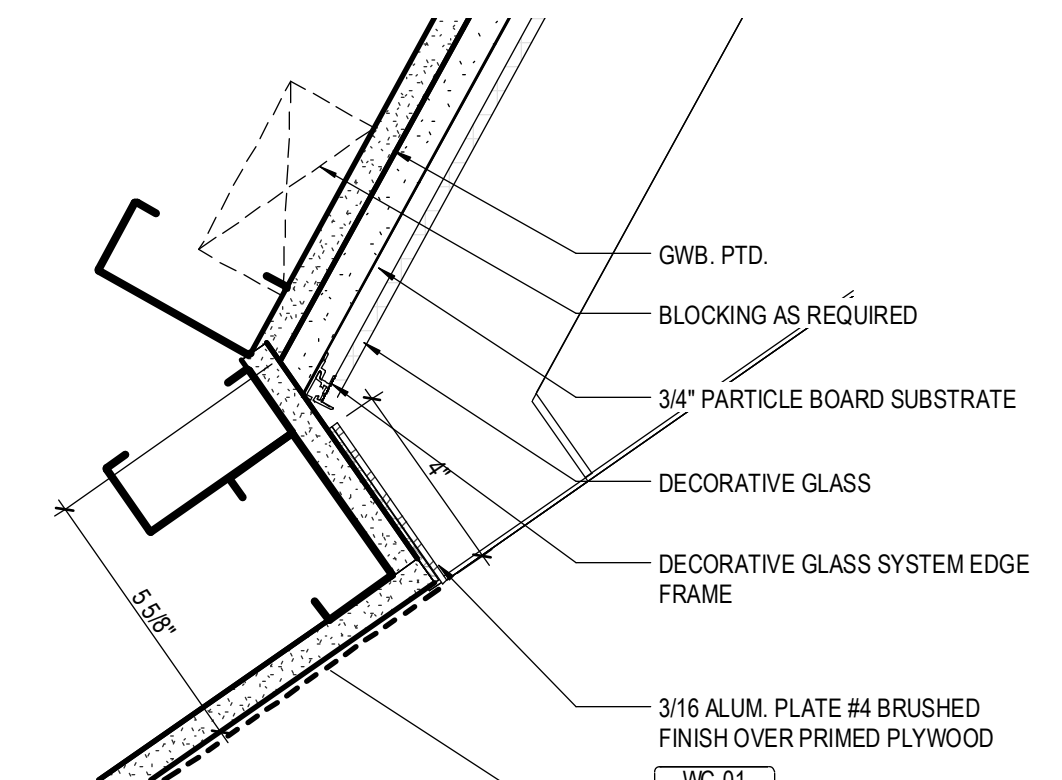

3 PLAN DETAIL RIGHT CONER
3" = 1'-0"

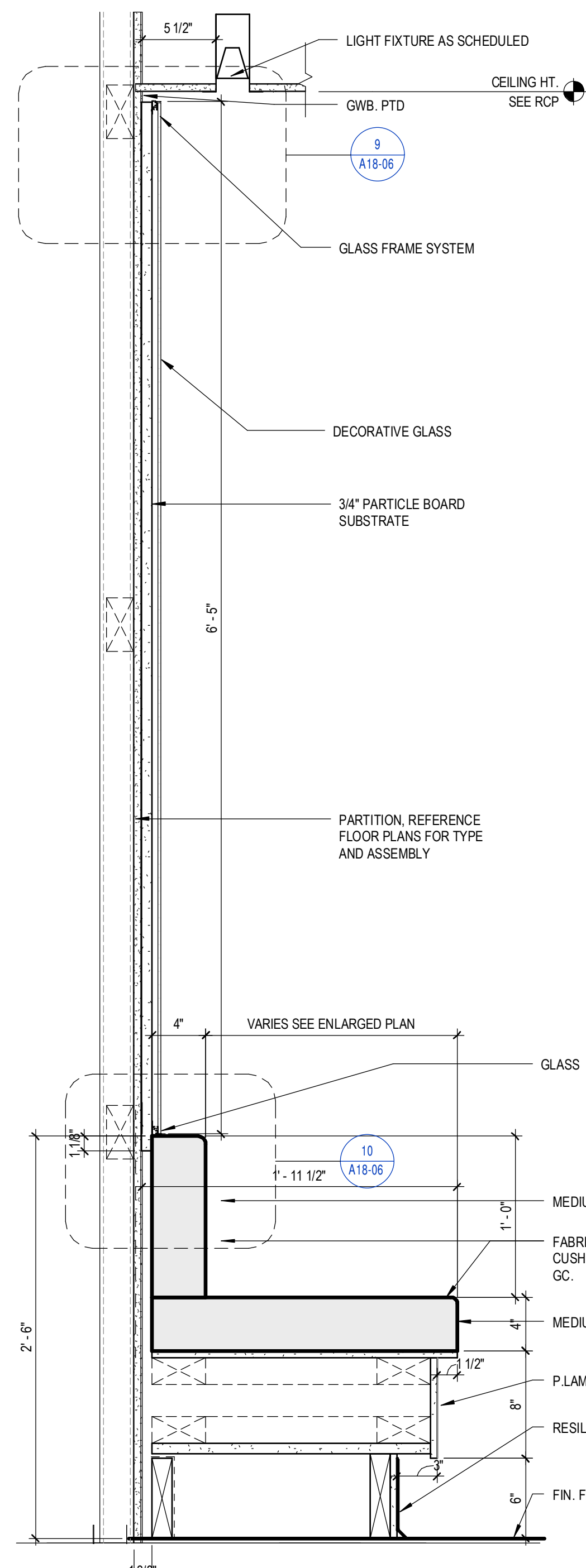

12 SECTION AT DECORATIVE GLASS WITH HIGH TOP BENCH
1 1/2" = 1'-0"

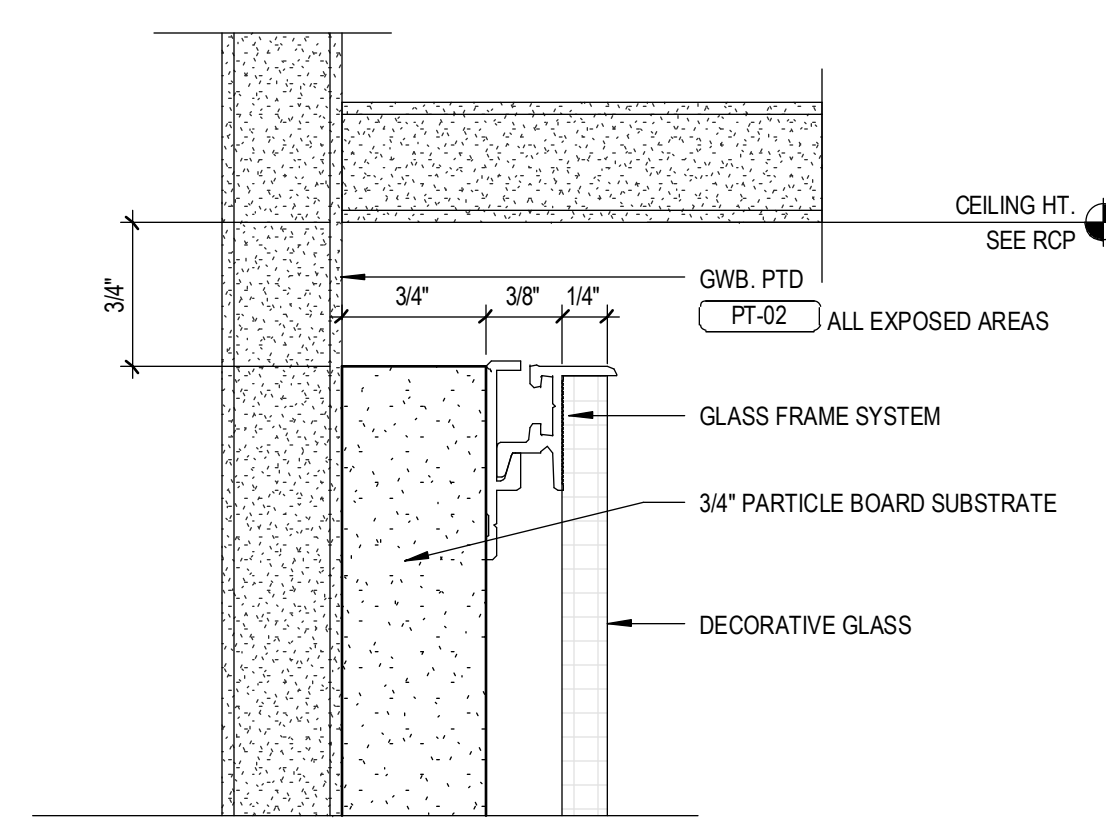

9 DETAIL AT TOP OF GLASS
12" = 1'-0"

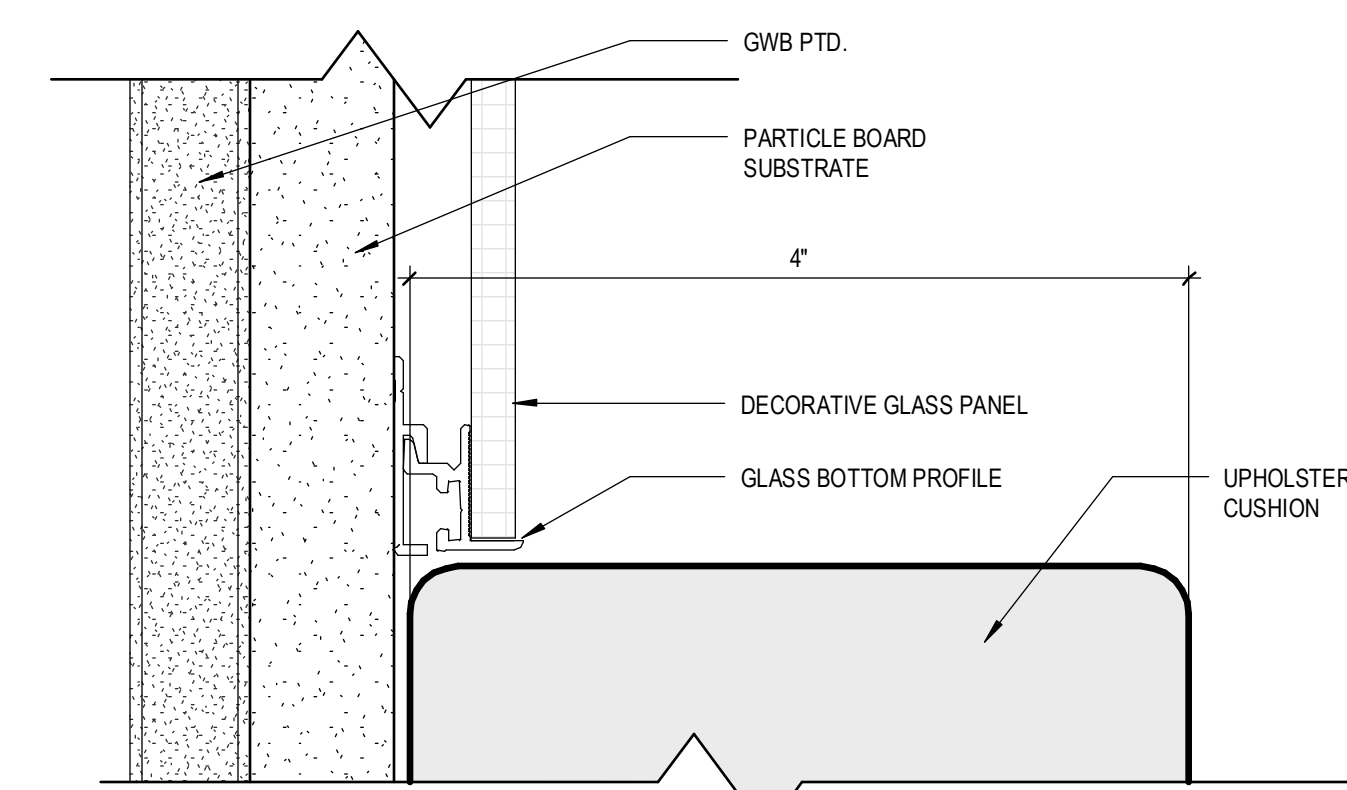

10 DETAIL GLASS BOTTOM FRAME
12" = 1'-0"

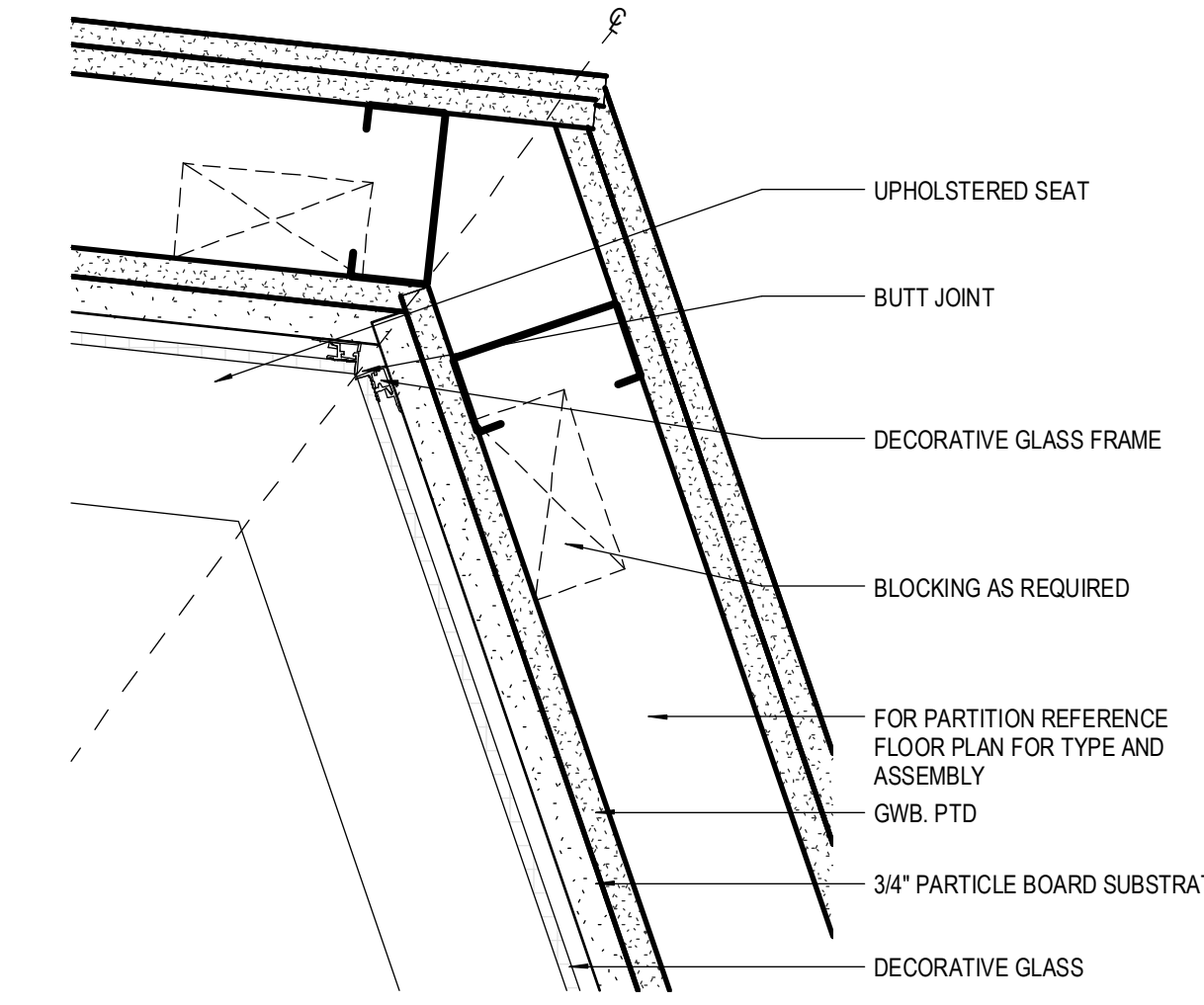

6 PLAN DETAIL BENCH CORNER
3" = 1'-0"

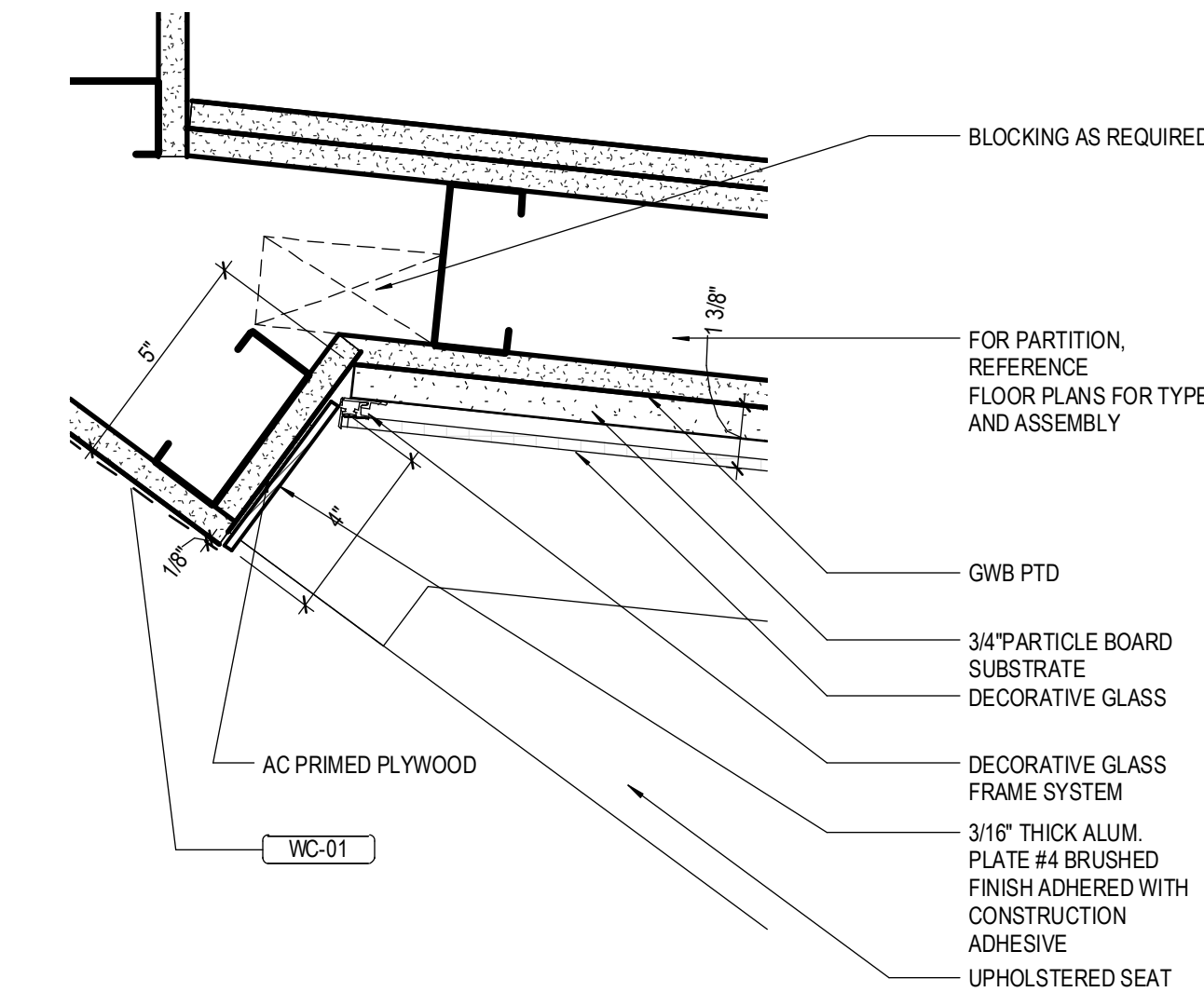

7 PLAN DETAIL CORNER LEFT
3" = 1'-0"

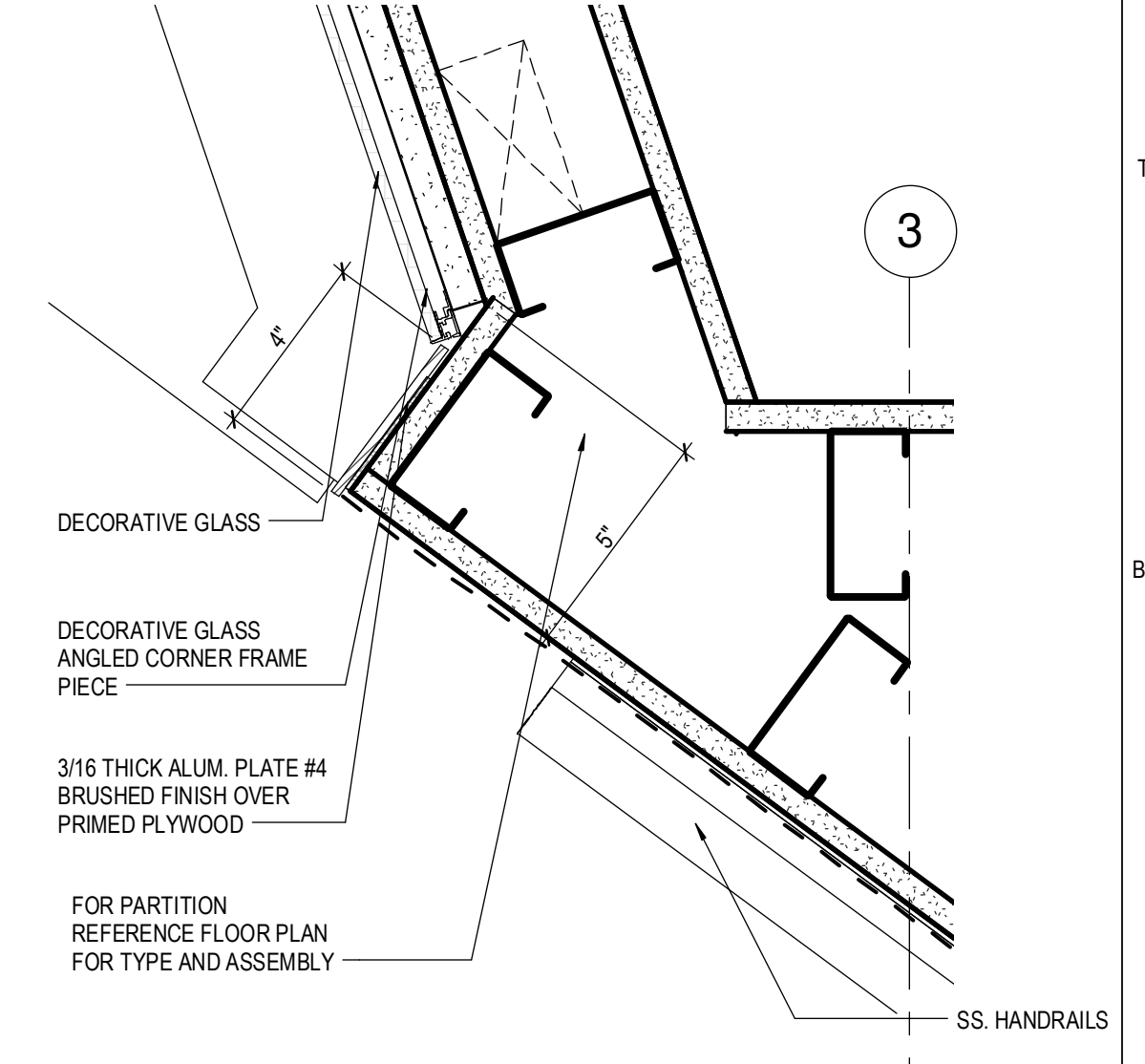

3 PLAN DETAIL CORNER RIGHT
3" = 1'-0"

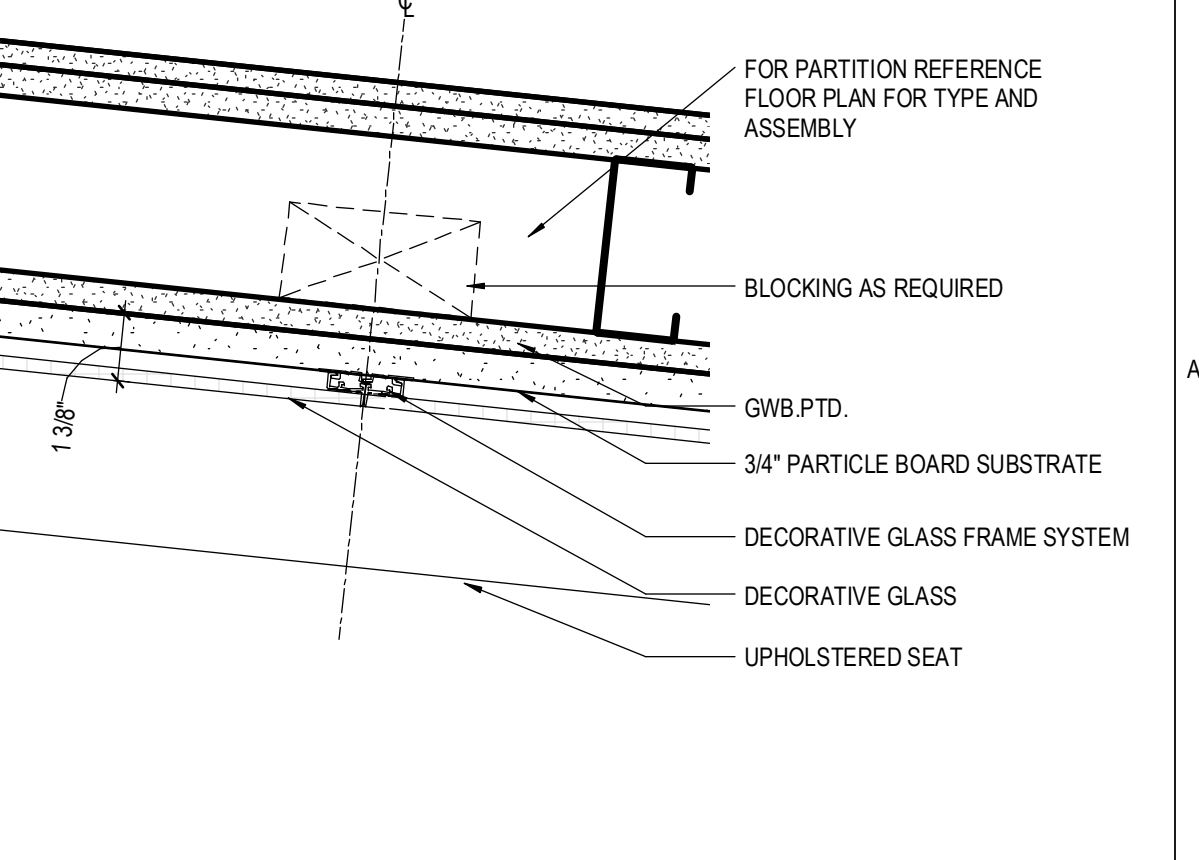

1 PLAN DETAIL - MIDDLE GLASS FRAME JOINT
3" = 1'-0"