

D5 TYPICAL WALL GRAZER
1 1/2" = 1'-0"

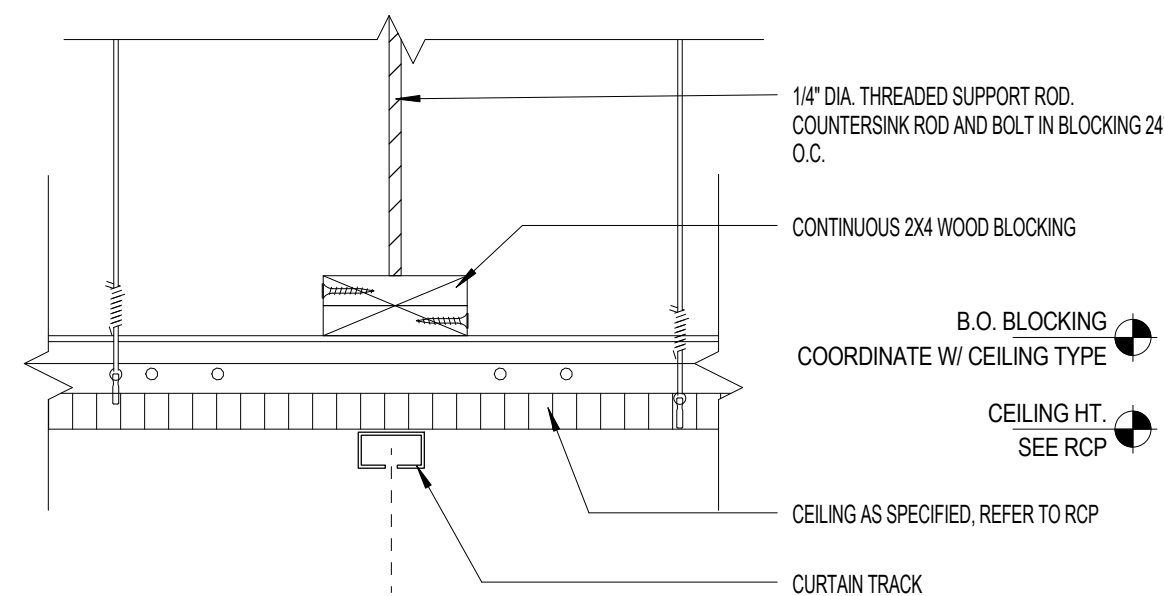

D4 CEILING DETAIL @ I.V. TRACK
3" = 1'-0"

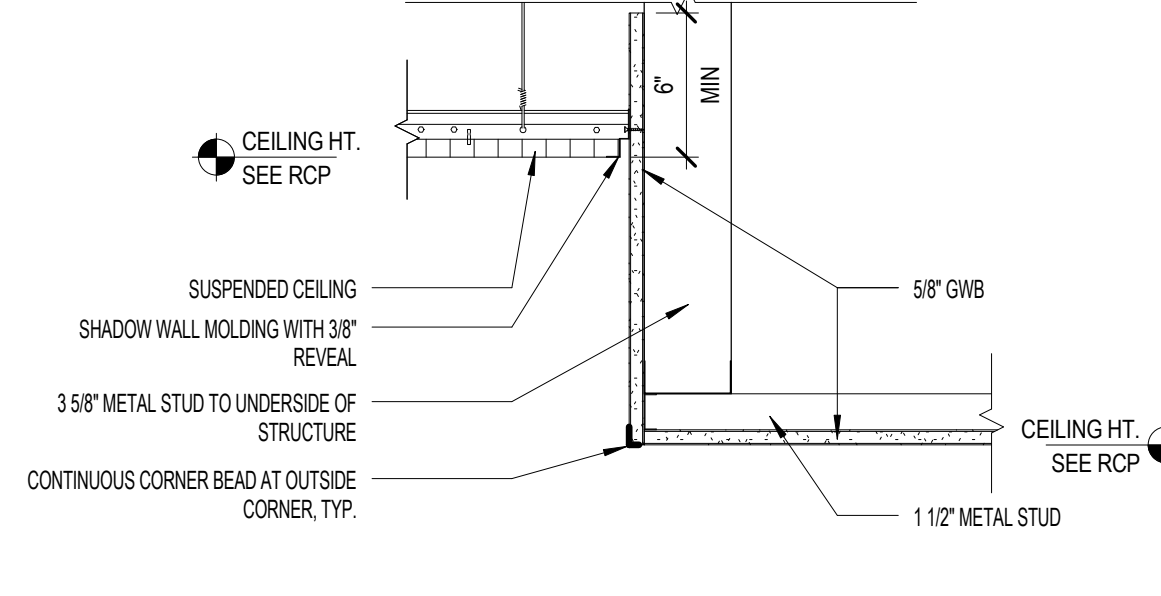

D3 CEILING DETAIL @ GWB/ACT SOFFIT
1 1/2" = 1'-0"

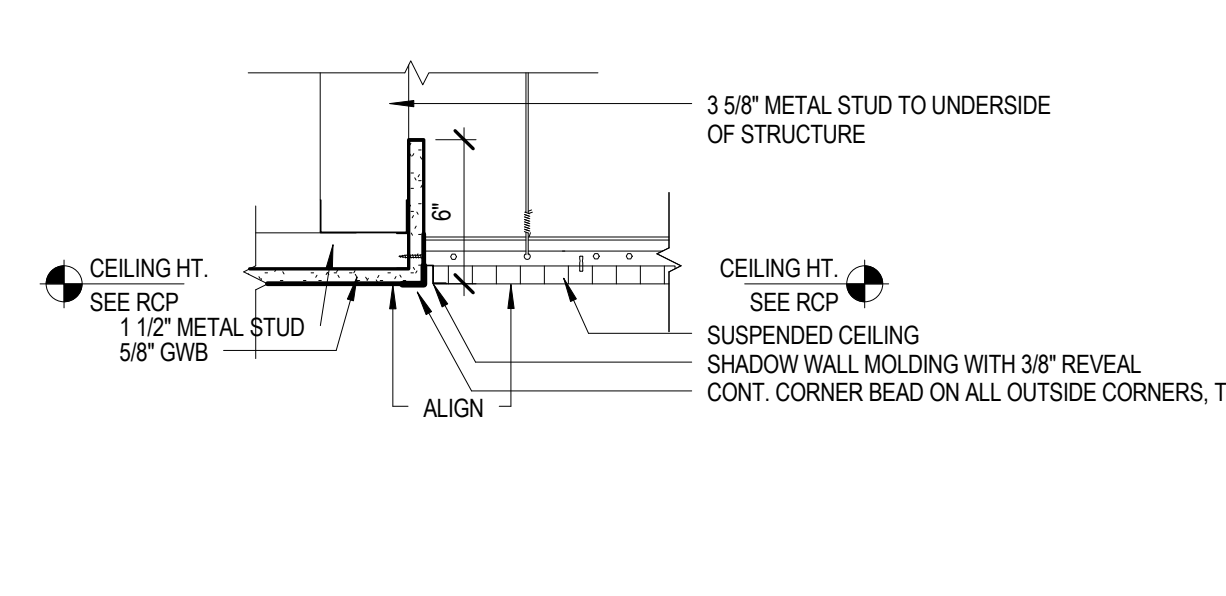

D2 CEILING DETAIL @ GWB/ACT COPLANAR
1 1/2" = 1'-0"

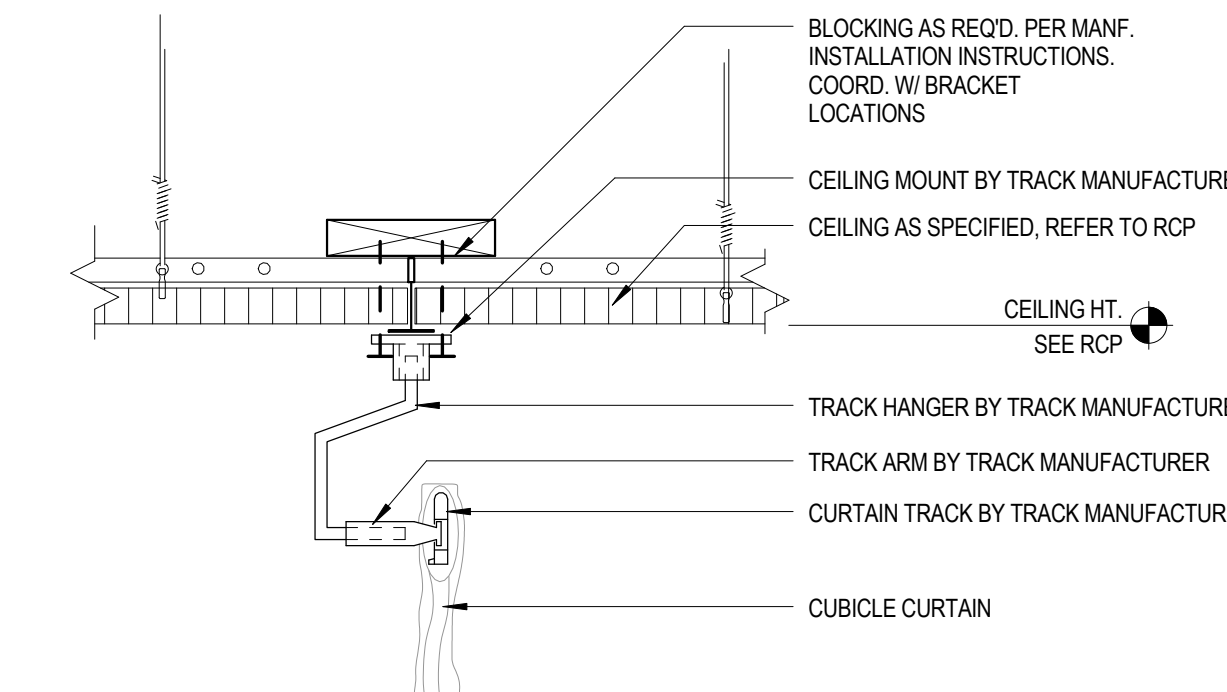

D1 CEILING DETAIL @ CUBICLE CURTAIN
3" = 1'-0"

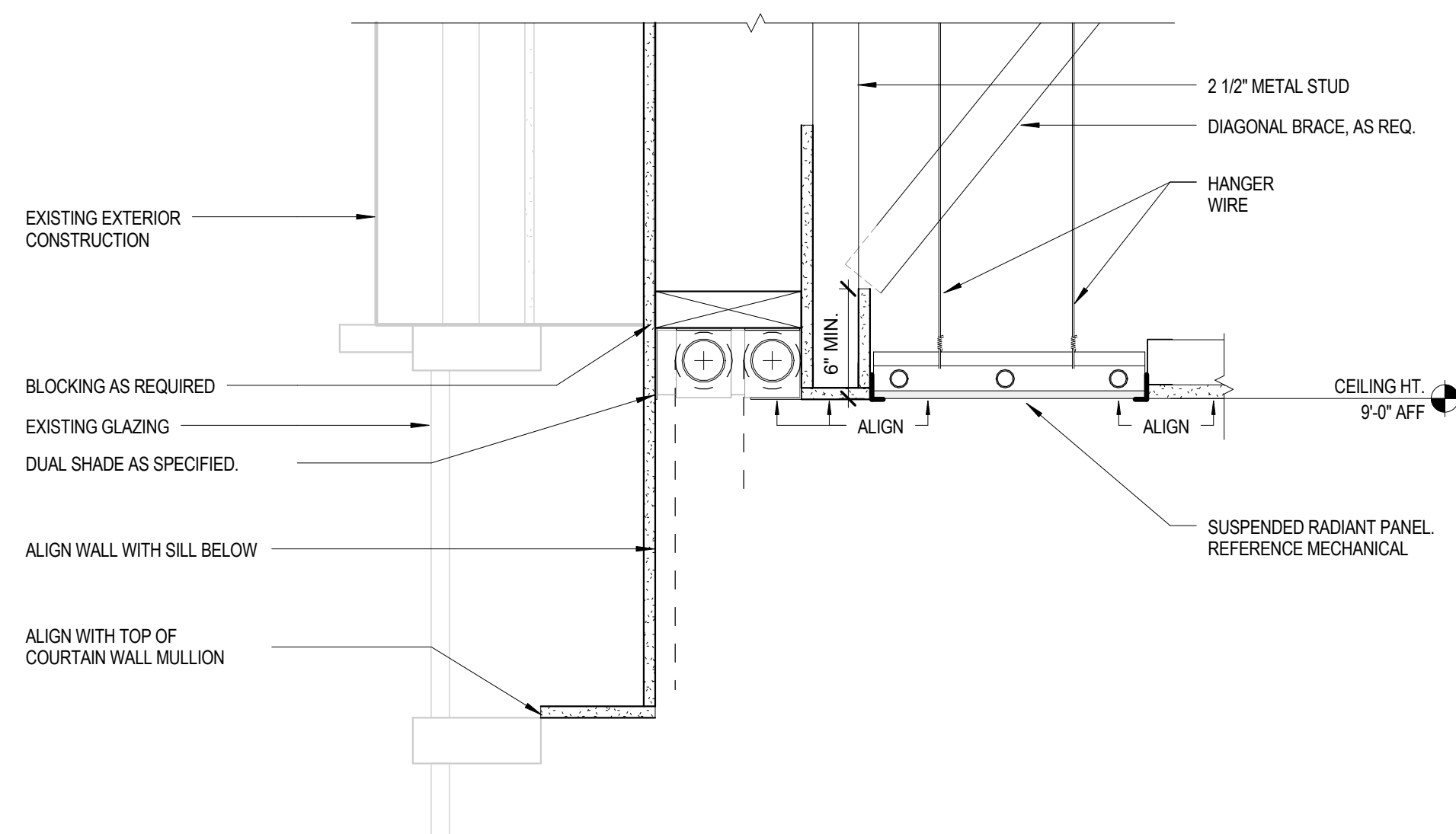

C5 DETAIL - CEILING AT PERIMETER
1 1/2" = 1'-0"

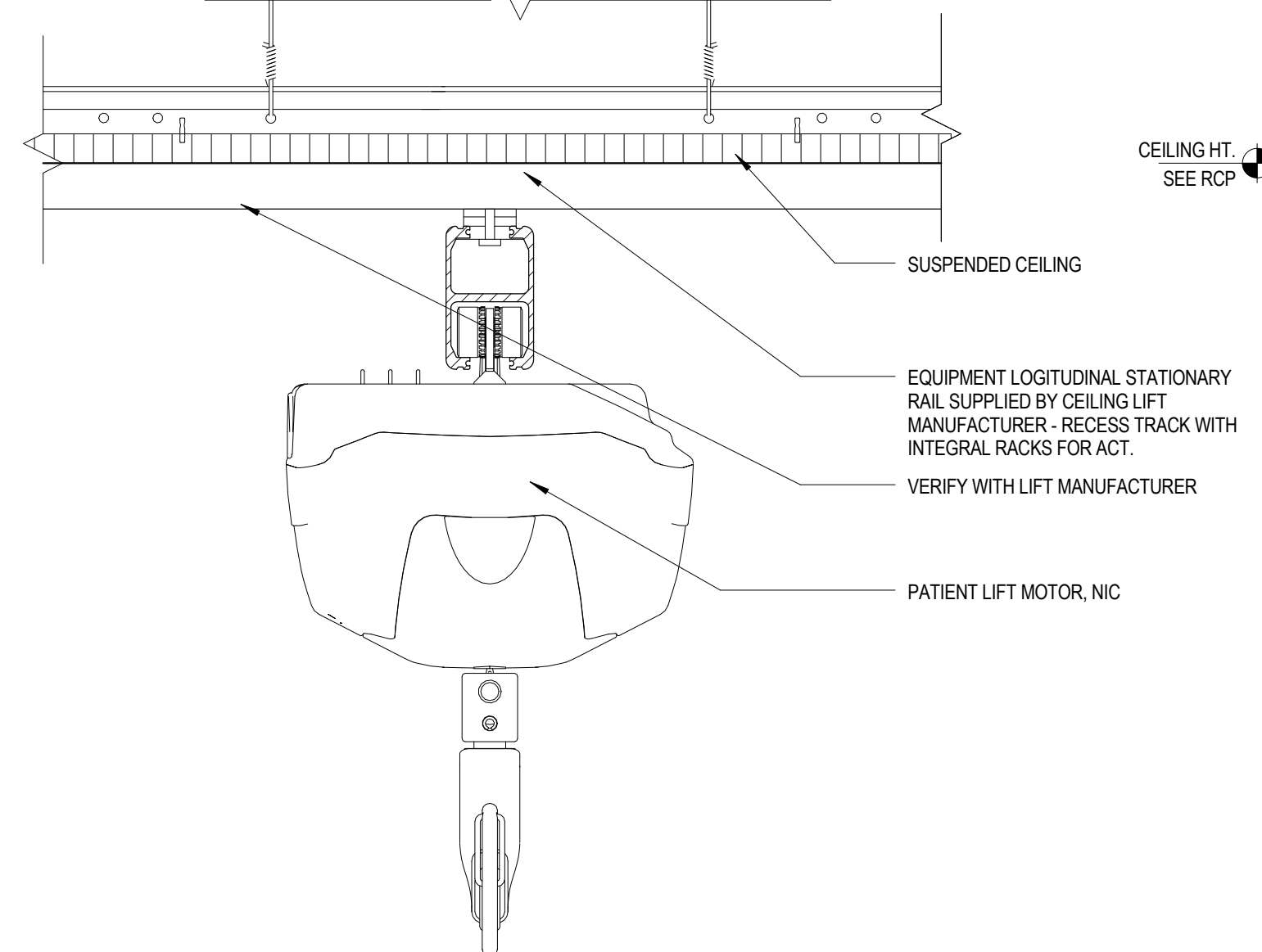

C3 PATIENT LIFT - RECESSED RAIL AND MOTOR
3" = 1'-0"

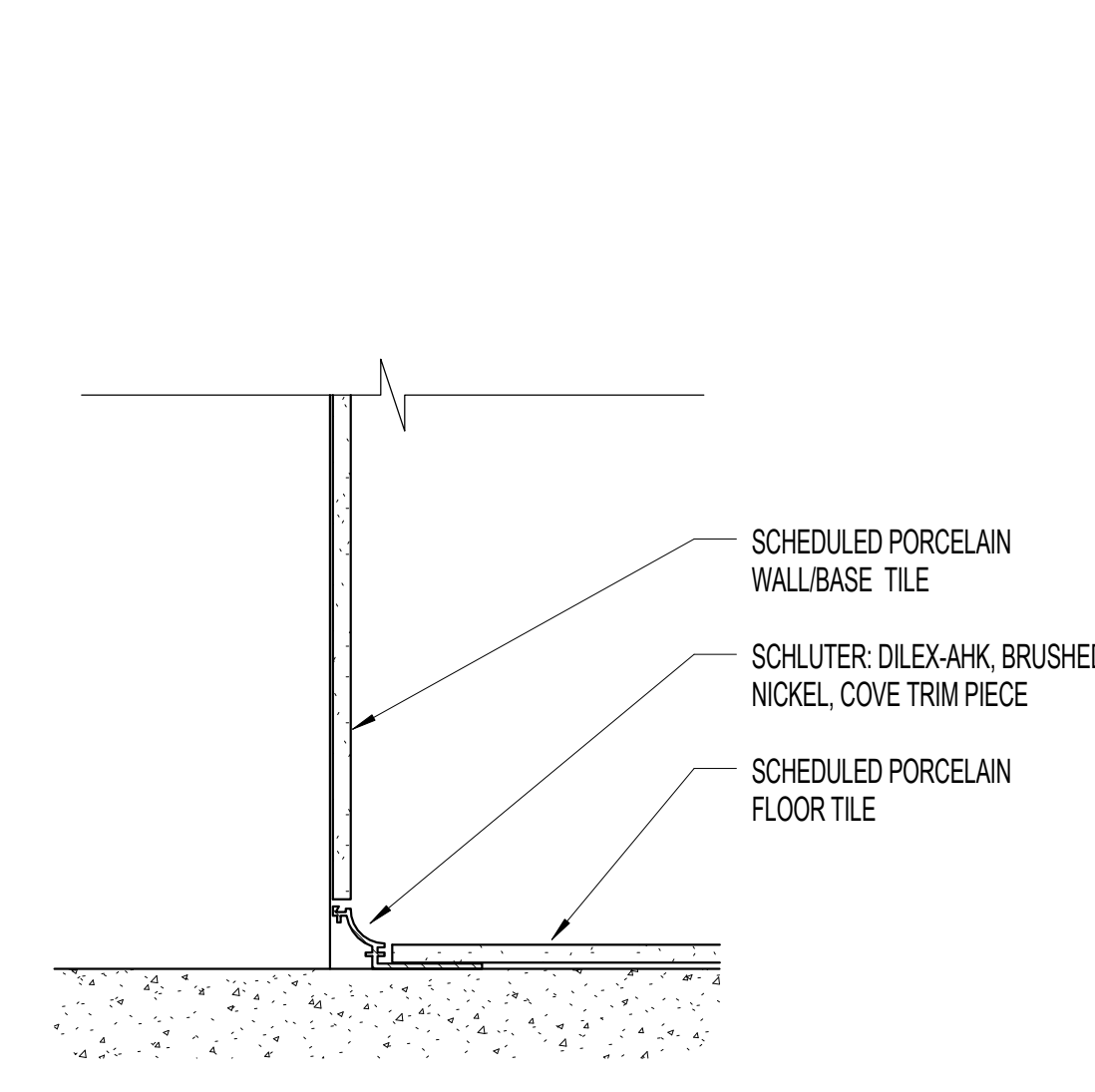

C2 SCHLUTER COVE TRIM
3" = 1'-0"

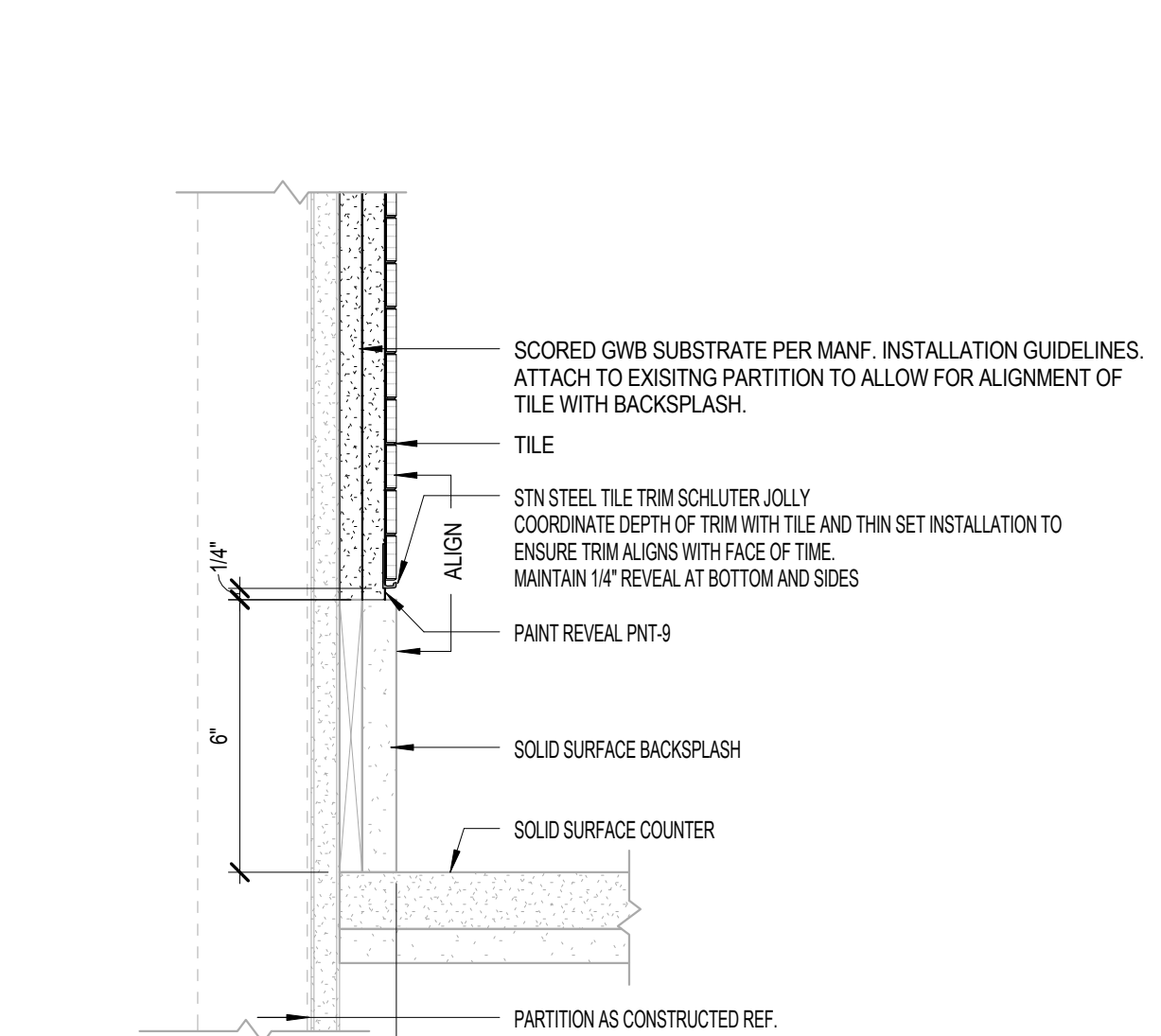

C1 DETAIL - TILE AT BACKSPASH
3" = 1'-0"

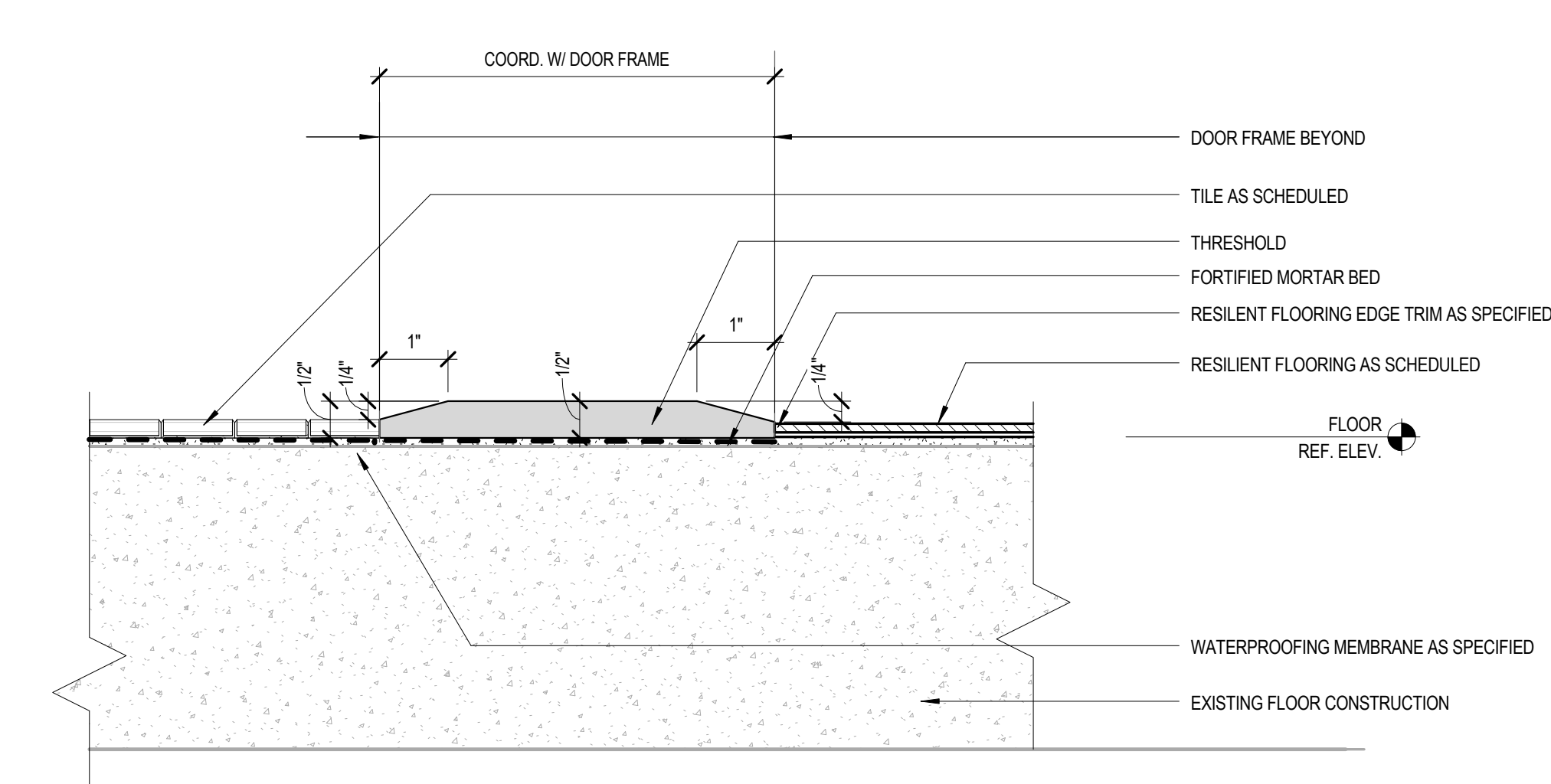

B5 DETAIL - THRESHOLD
6" = 1'-0"

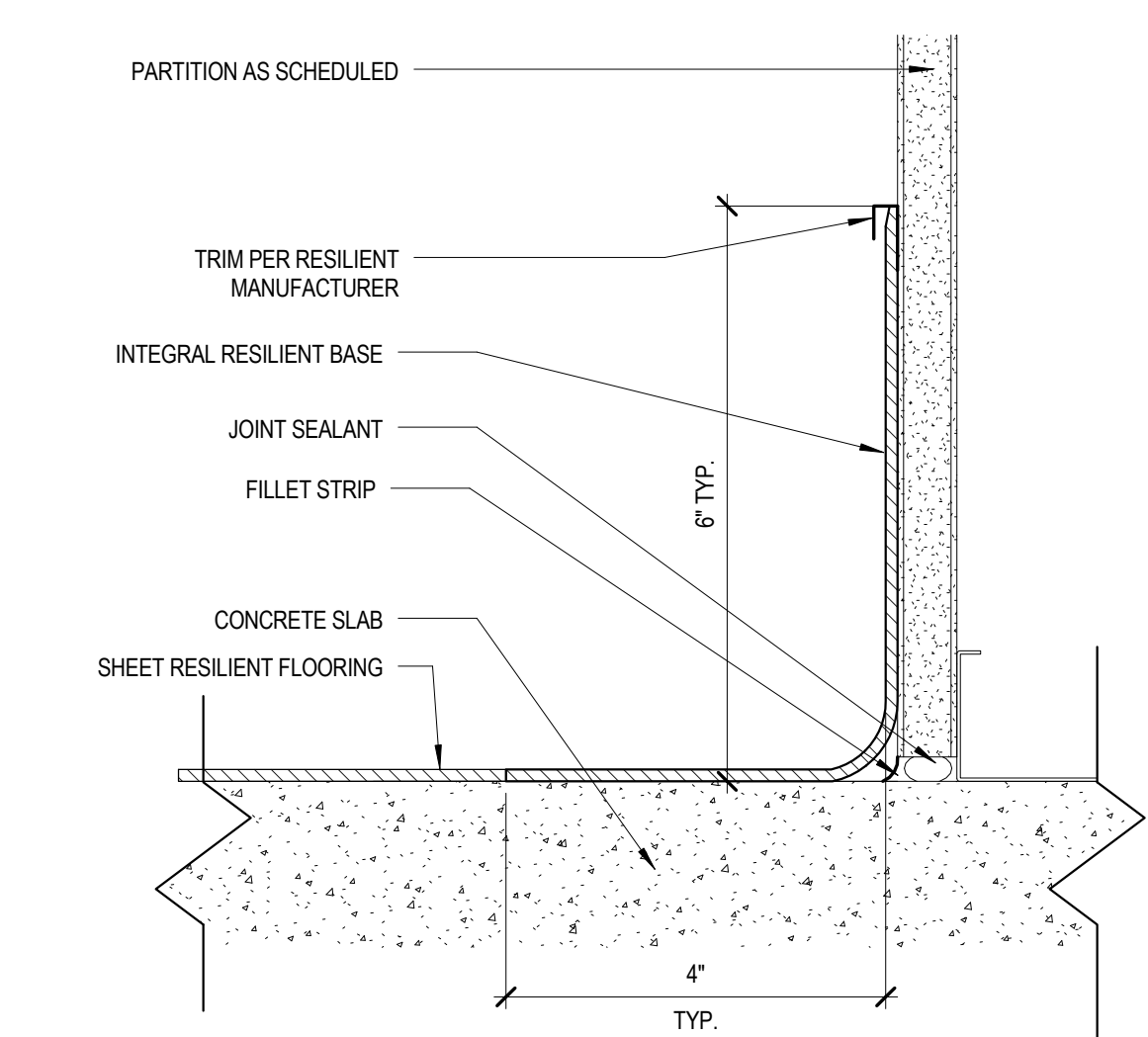

B3 WALL BASE DETAIL RESILIENT BASE
@ SHEET RESILIENT FLOORING
6" = 1'-0"

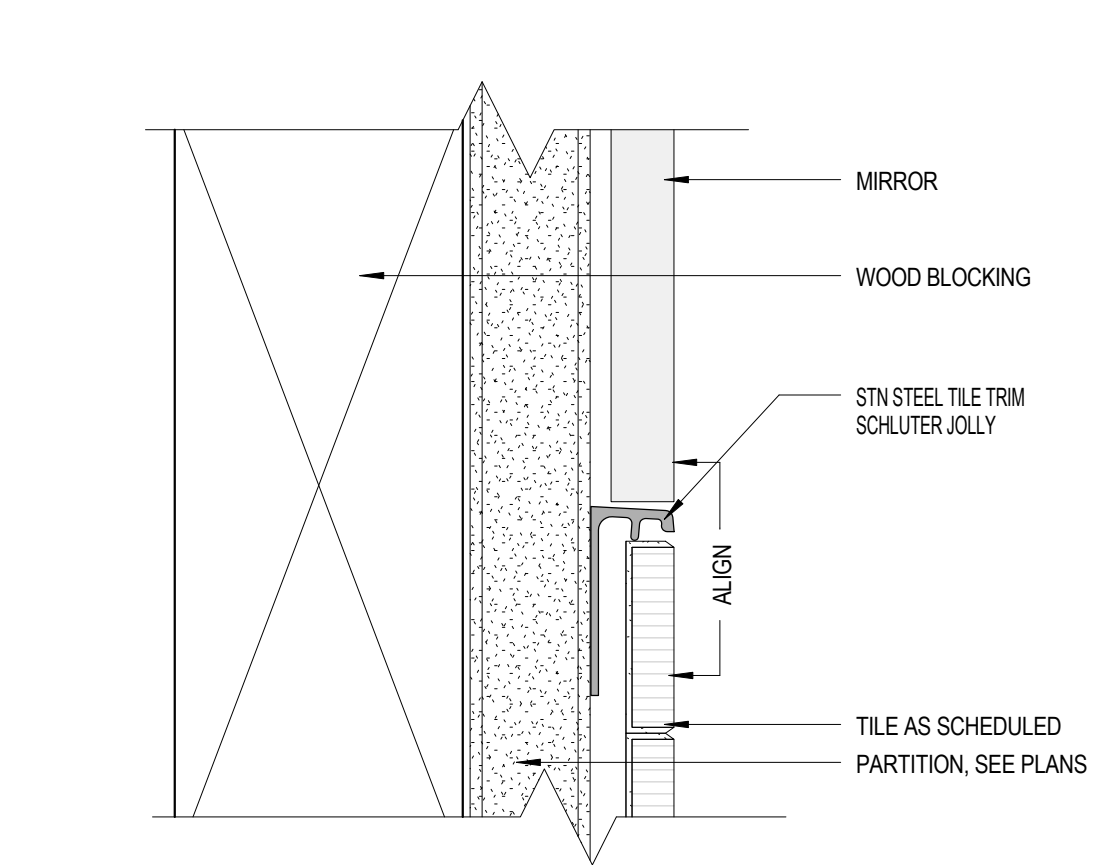

B2 MIRROR EDGE DETAIL
12" = 1'-0"

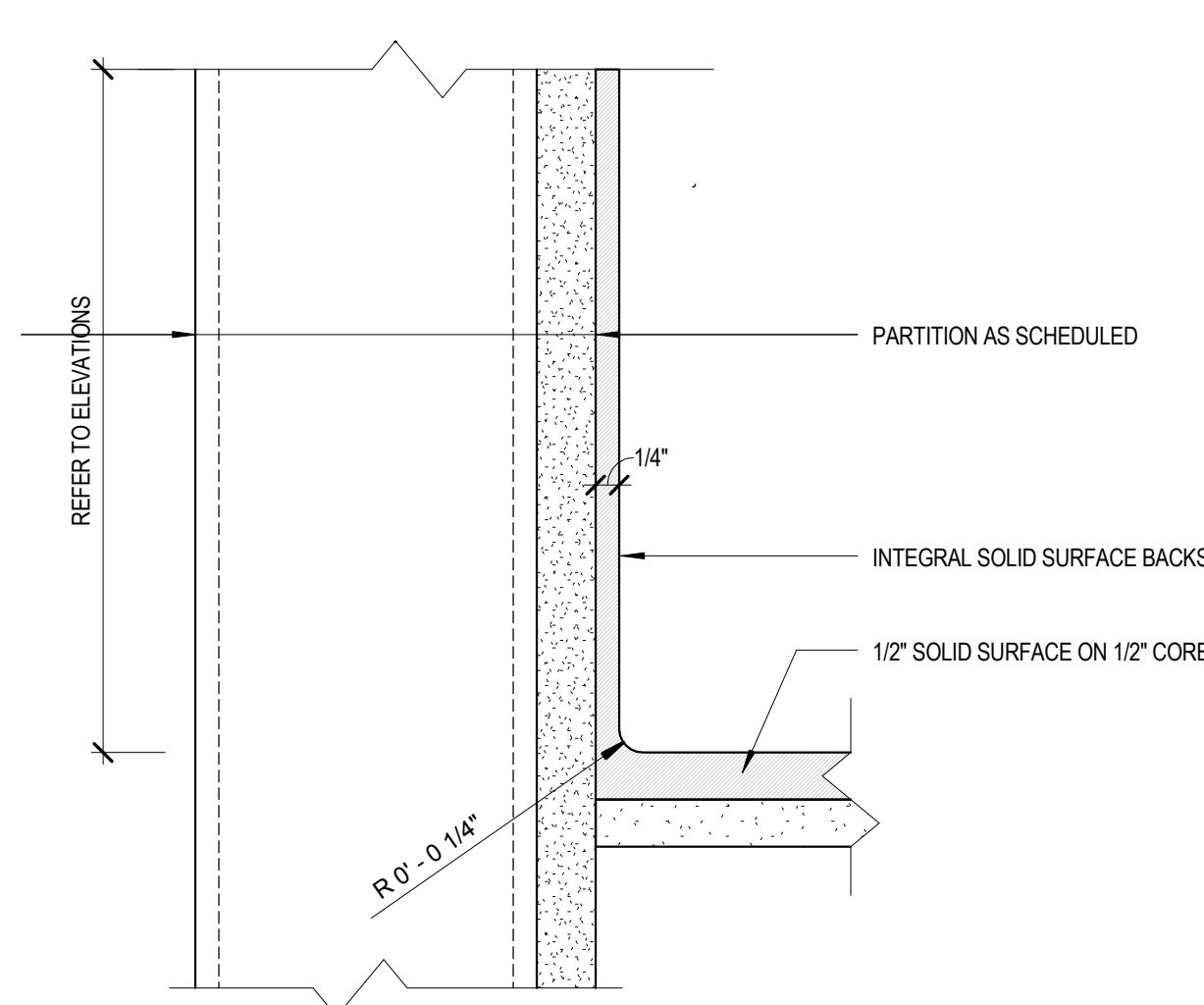

B1 DETAIL - INTEGRAL BACKSPASH
6" = 1'-0"

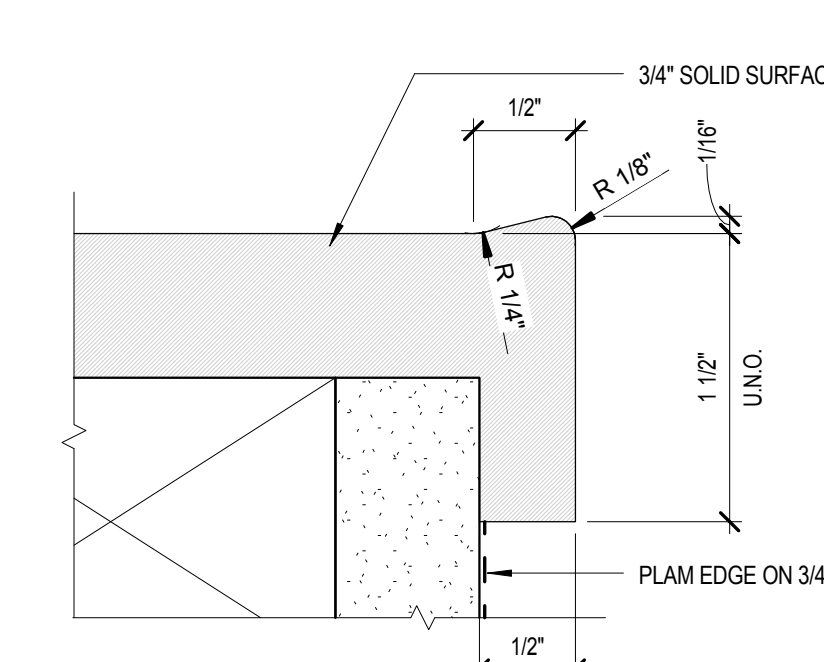

A5 SOLID SURFACE MARINE EDGE
12" = 1'-0"

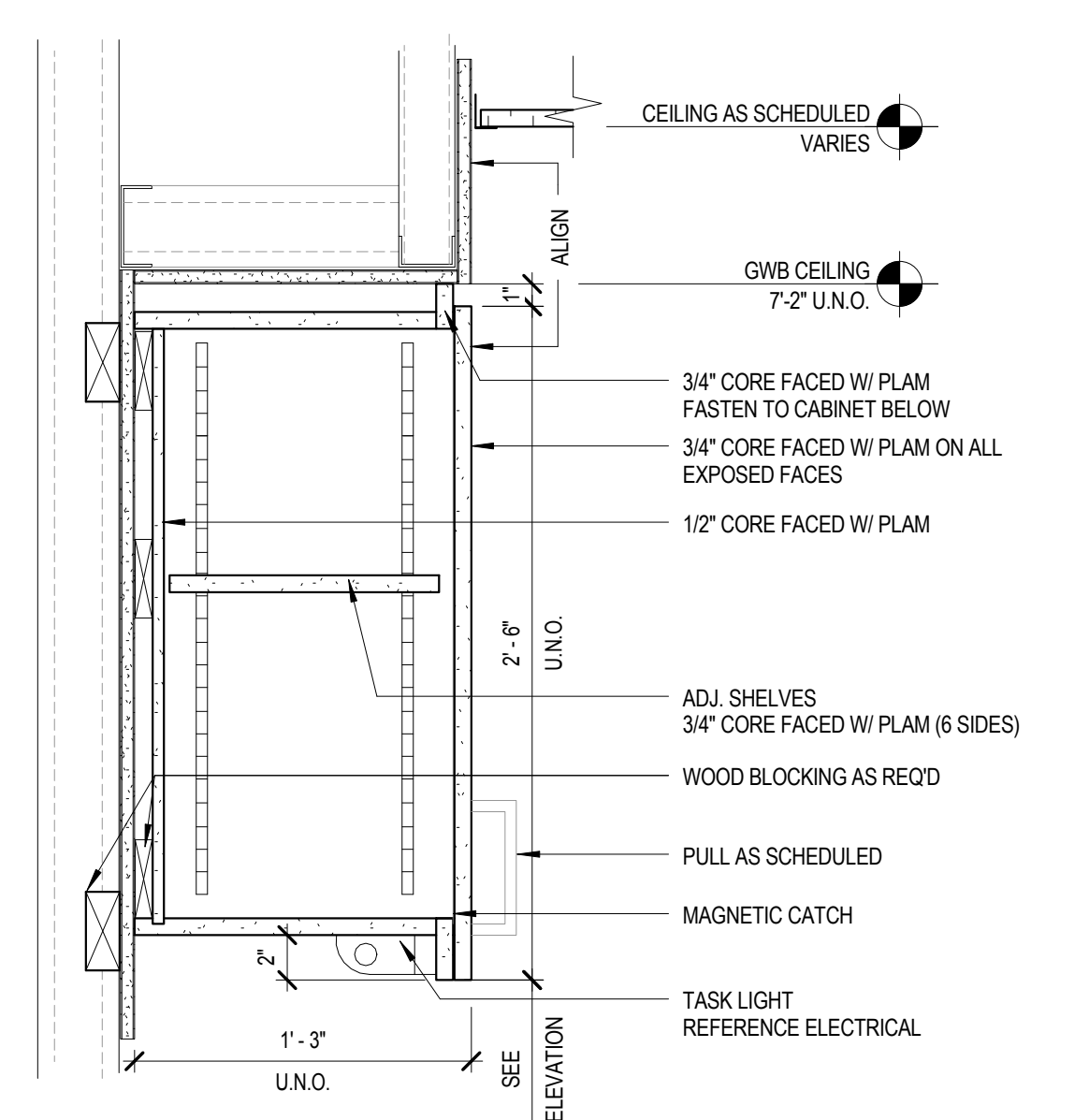

A4 WALL CABINET
1 1/2" = 1'-0"

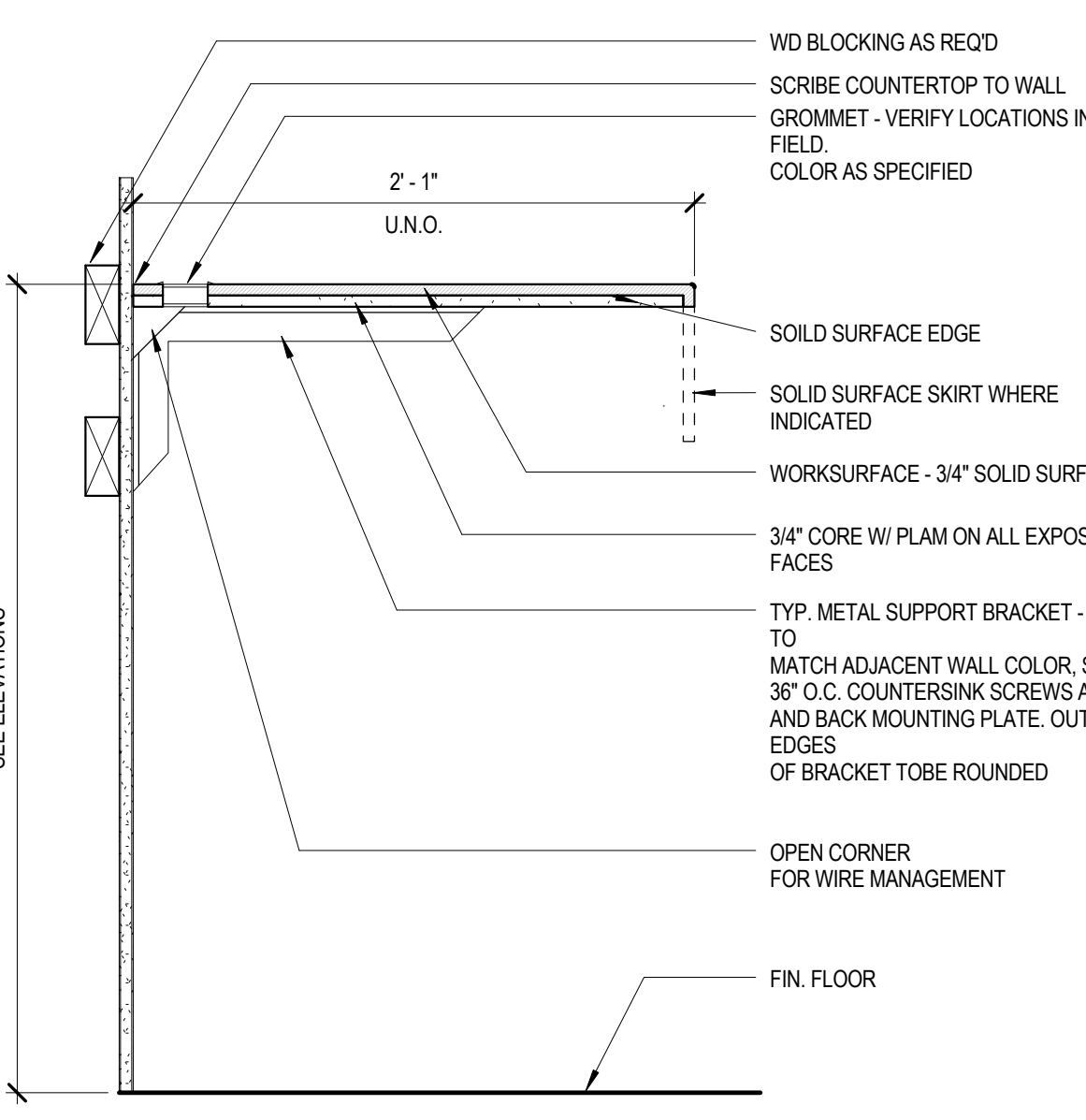

A3 COUNTER - SOLID SURFACE
1 1/2" = 1'-0"

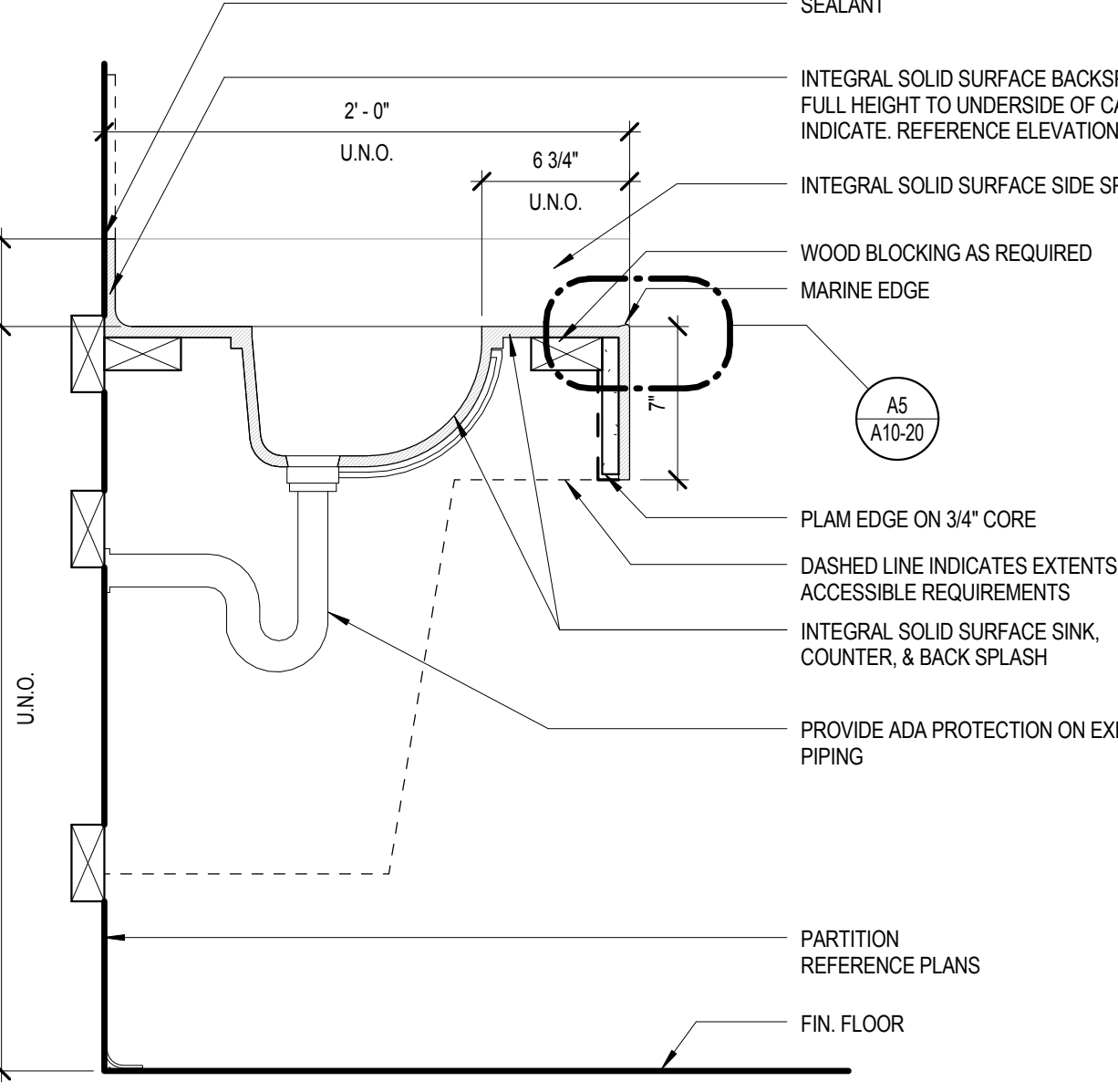

A2 COUNTER W/ INTEGRAL SINK - ROUND
1 1/2" = 1'-0"

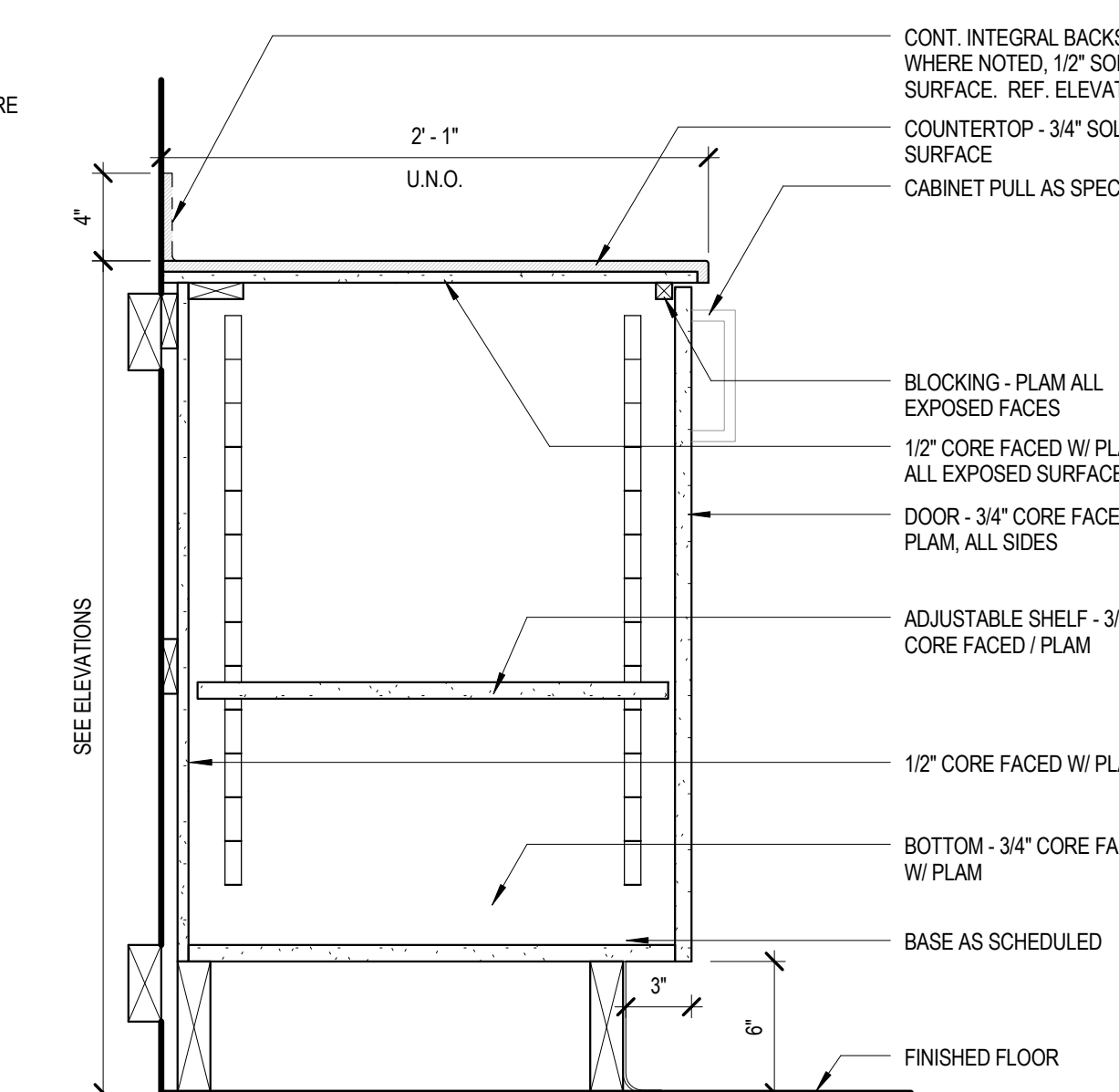

A1 BASE CABINET W/SHELF - SOLID SURFACE
1 1/2" = 1'-0"

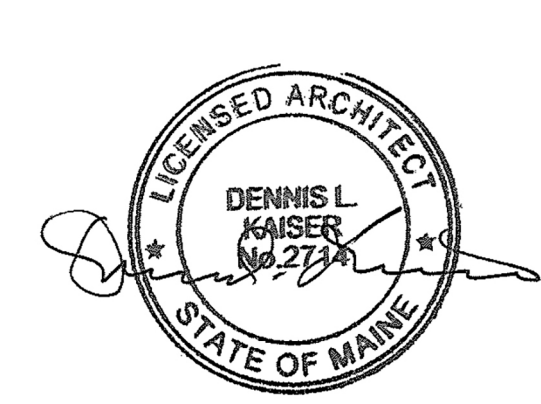

Revisions

NO.	ISSUE	DATE

ISSUED FOR PERMIT 09.15.16
NO. 1521XX-XXXX DATE 09.15.16

Sheet Information
Date September 15, 2016
Drawn 1521XX-XXXX
Job Number JPK
Checked
Approved

Title
ARCHITECTURAL
DETAILS

Sheet
A10-20