

MAINE MEDICAL CENTER

**MMC SCU2
RENOVATIONS**

22 Bramhall Street, Portland, ME,
04102

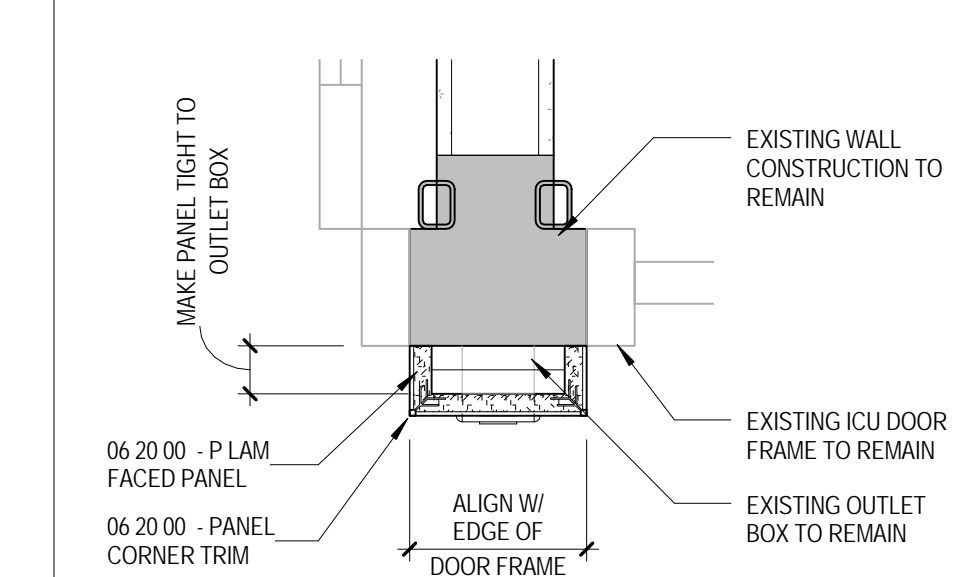

F13 PLAN DETAIL - PLAM OUTLET COVER - TYP.
A7.1s 1/16" = 1'-0"

NO.	DESCRIPTION	DATE

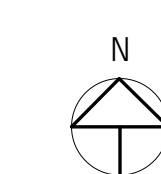

CONTENT:
MILLWORK DETAILS

DRAWN BY:	Author
PROJECT NO.:	15-072-00
DATE:	01/22/16
REVISED:	
SCALE:	As Indicated

A7.1s

Project Phase:
ISSUED FOR PERMIT
COPYRIGHT © 2016 BY LAVALLEEBRENSINGER PROFESSIONAL ASSOCIATION. ALL RIGHTS RESERVED. NO REPRODUCTION WITHOUT PERMISSION.

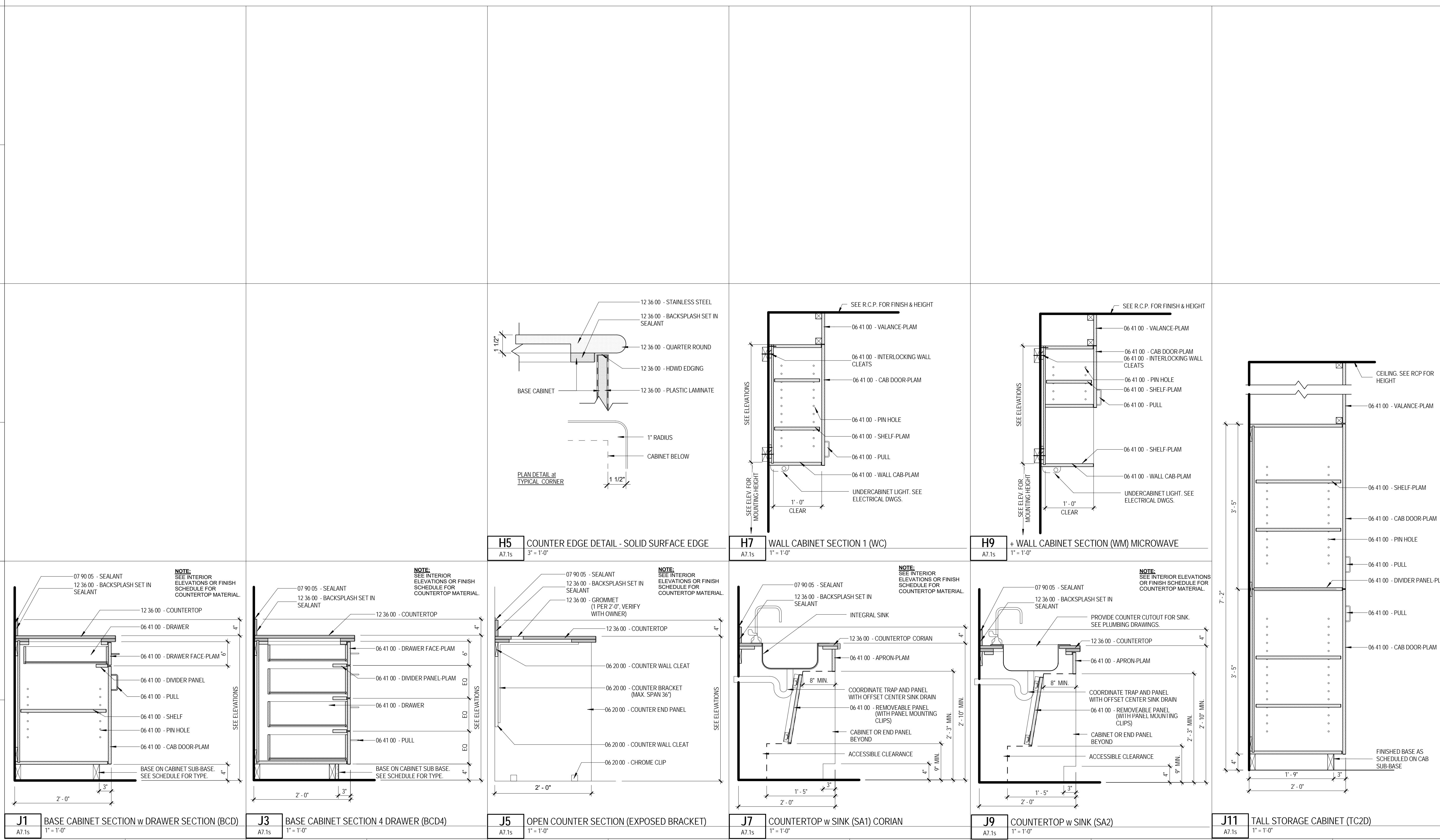

J1 BASE CABINET SECTION W/ DRAWER SECTION (BCD) A7.1s 1" = 1'-0"
J3 BASE CABINET SECTION 4 DRAWER (BCD4) A7.1s 1" = 1'-0"
J5 OPEN COUNTER SECTION (EXPOSED BRACKET) A7.1s 1" = 1'-0"
J7 COUNTERTOP w/ SINK (SA1) CORIAN A7.1s 1" = 1'-0"
J9 COUNTERTOP w/ SINK (SA2) A7.1s 1" = 1'-0"
J11 TALL STORAGE CABINET (TC2D) A7.1s 1" = 1'-0"
J13 PLAM OUTLET COVER - TYP. A7.1s 3/4" = 1'-0"