

1 LOW PRESSURE BRANCH TAKE OFF
SCALE: NTS

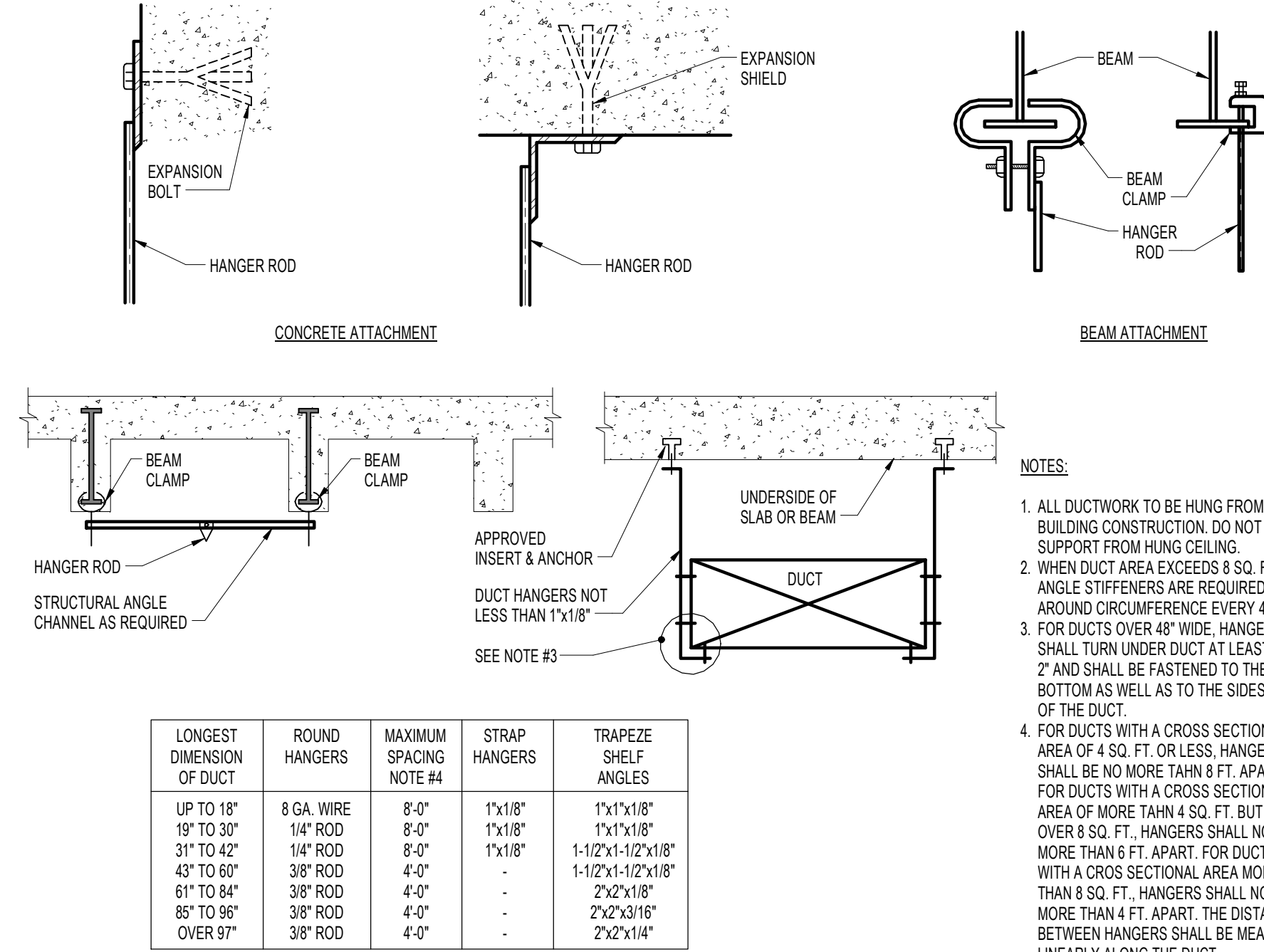

2 DUCT SUPPORT
SCALE: NTS

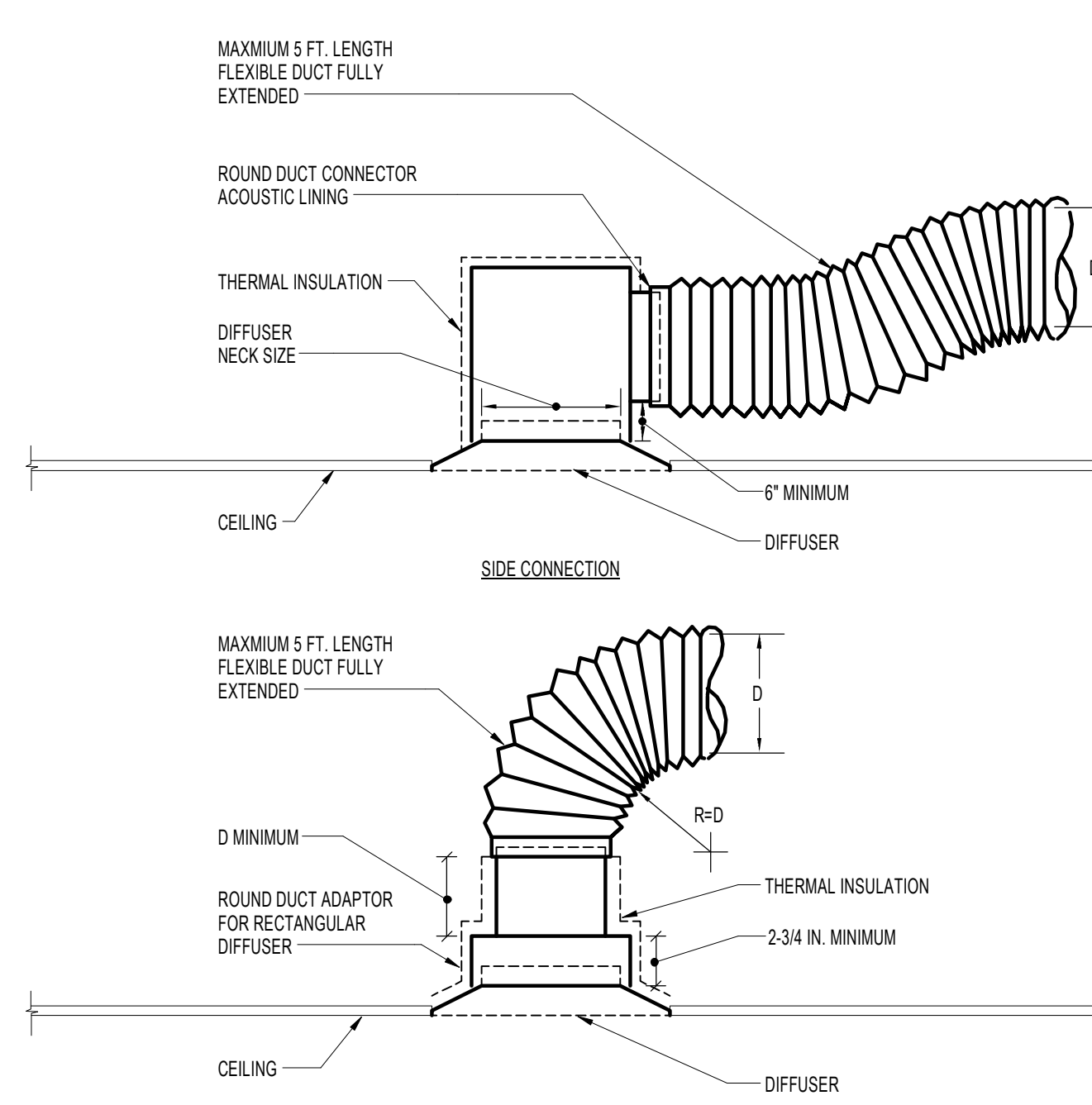

3 DIFFUSER CONNECTION
SCALE: NTS

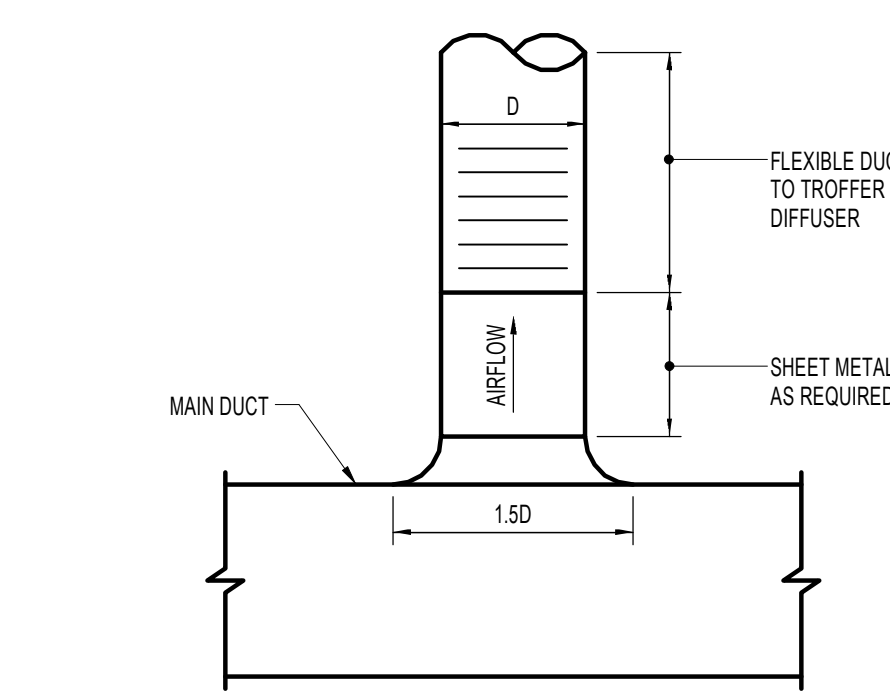

4 CIRCULAR BRANCH CONNECTION TO SINGLE OUTLET
SCALE: NTS

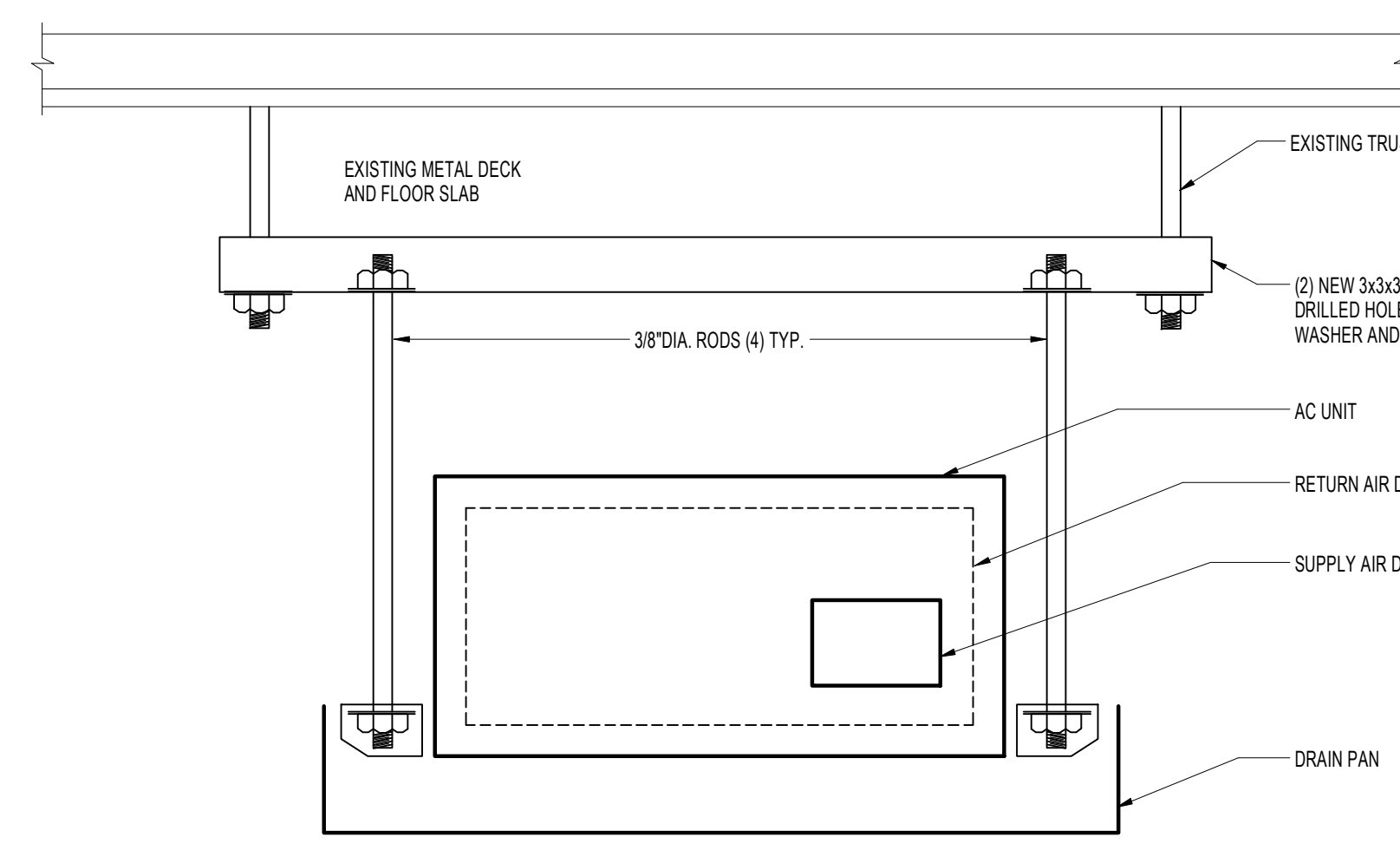

5 AC UNIT SUPPORT
SCALE: NTS

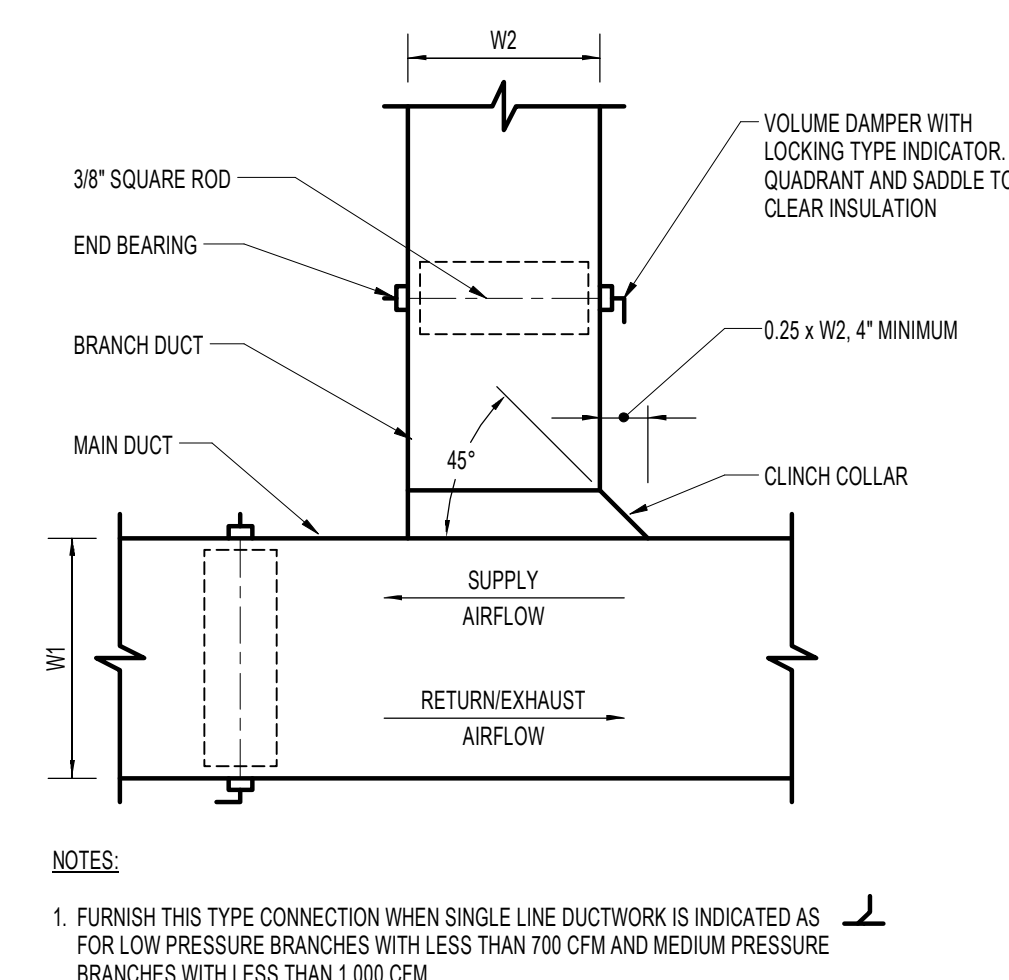

6 RECTANGULAR DUCT ANGULAR TAP WITH VOLUME DAMPER
SCALE: NTS

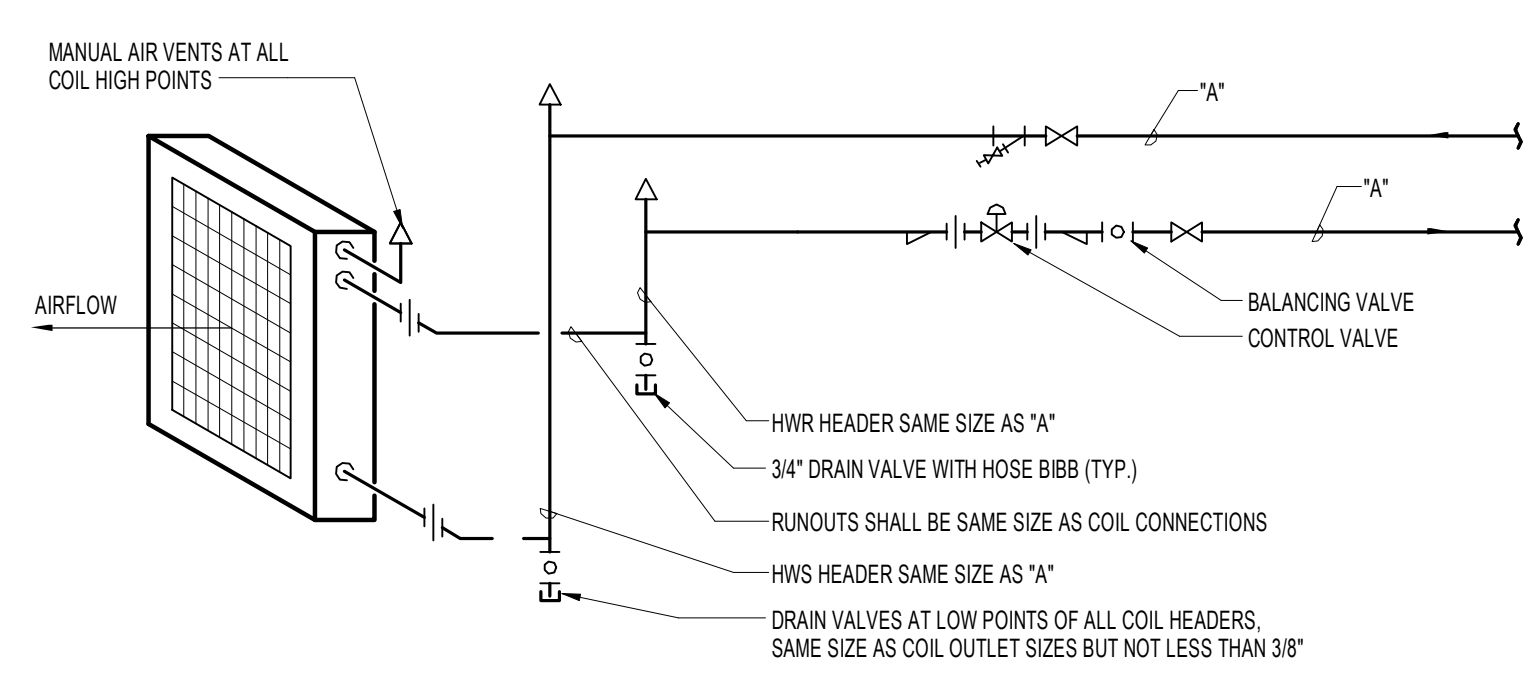

7 HOT WATER REHEAT COIL CONNECTIONS ONE HIGH
SCALE: NTS

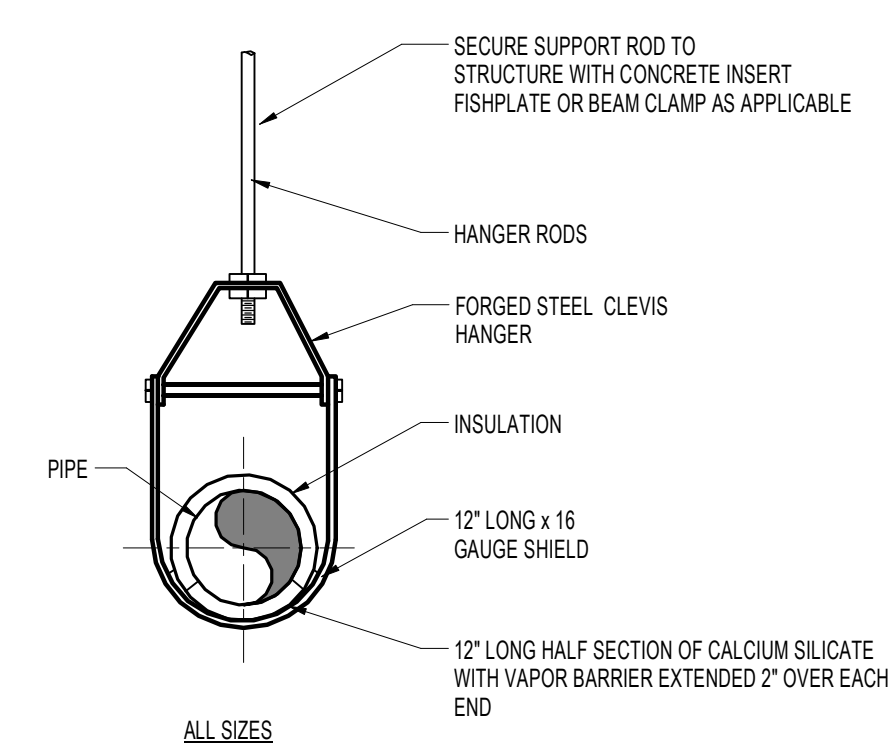

8 WATER PIPING HANGER
SCALE: NTS

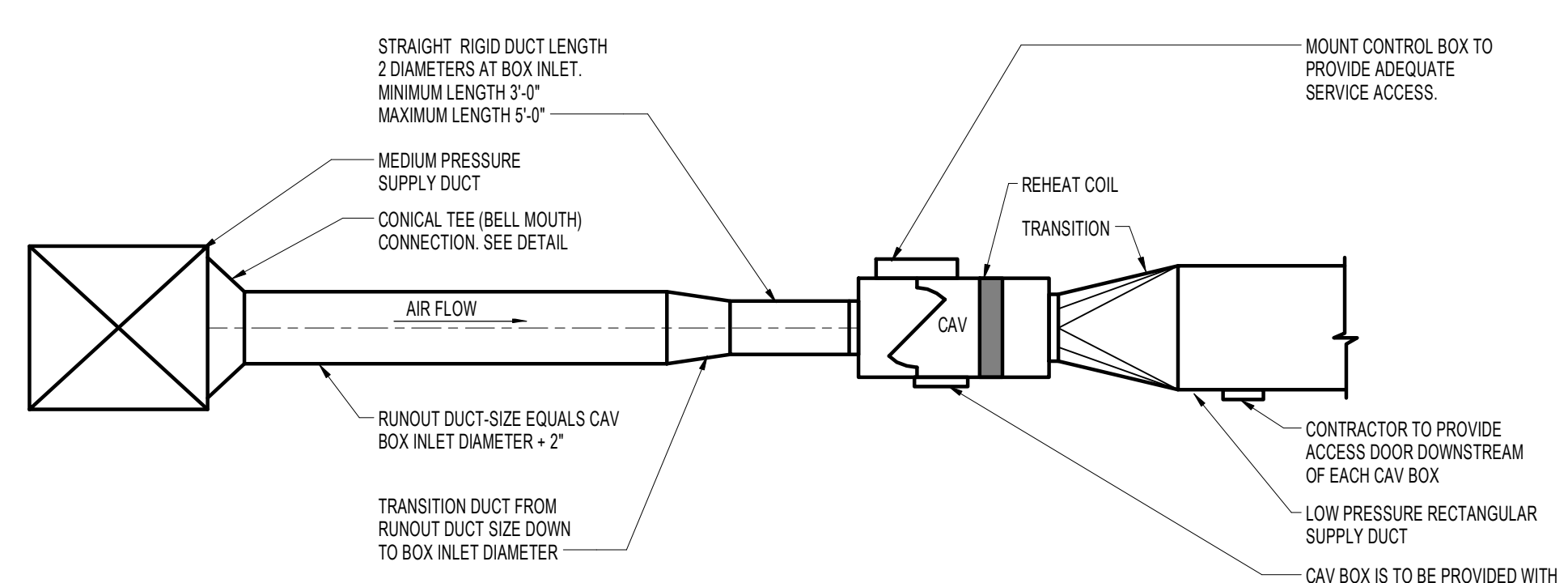

9 TERMINAL REHEAT BOX CONNECTIONS (CAV OR VAV)
SCALE: NTS

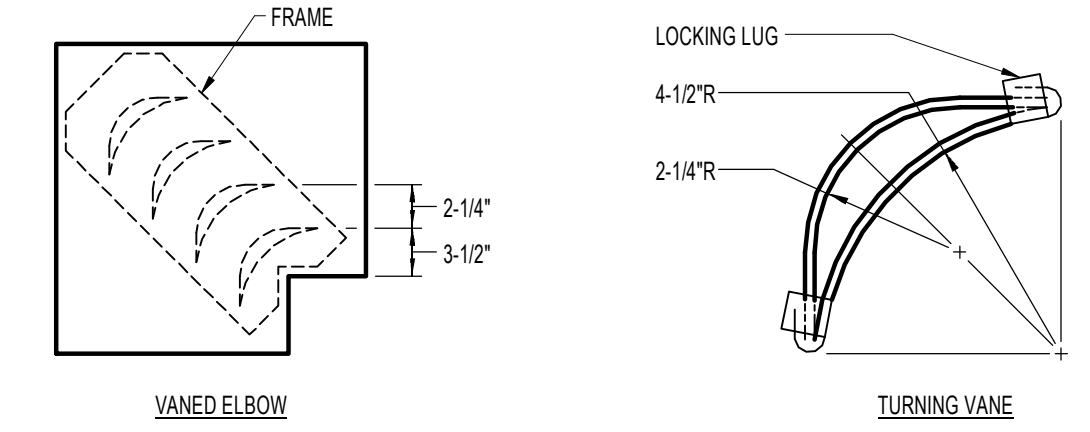

10 DOUBLE THICKNESS TURNING VANES FOR SQUARE ELBOWS
SCALE: NTS

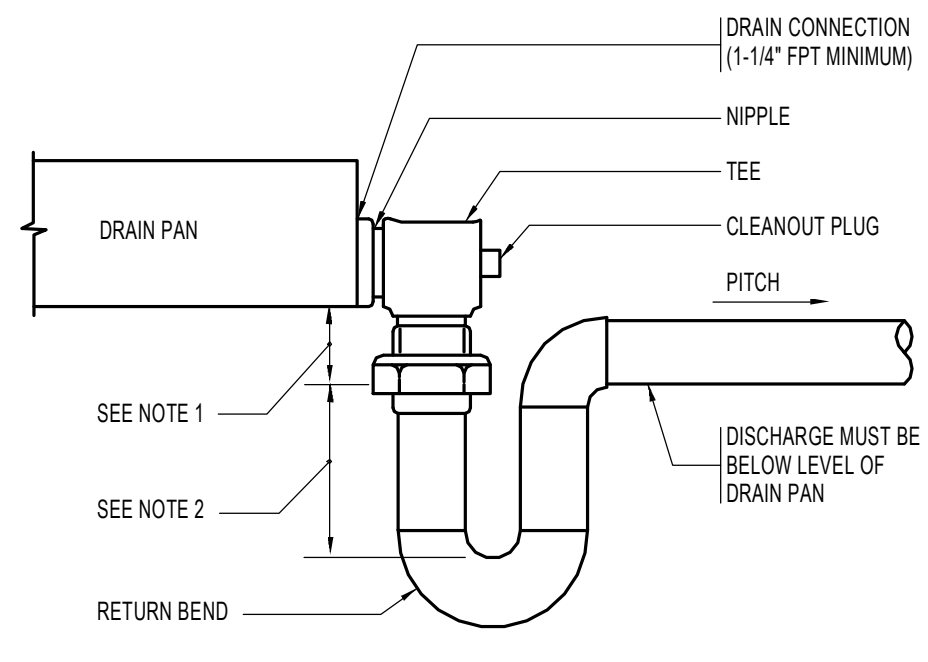

11 DRAIN PAN WATER SEAL PIPING DRAW THRU UNIT
SCALE: NTS

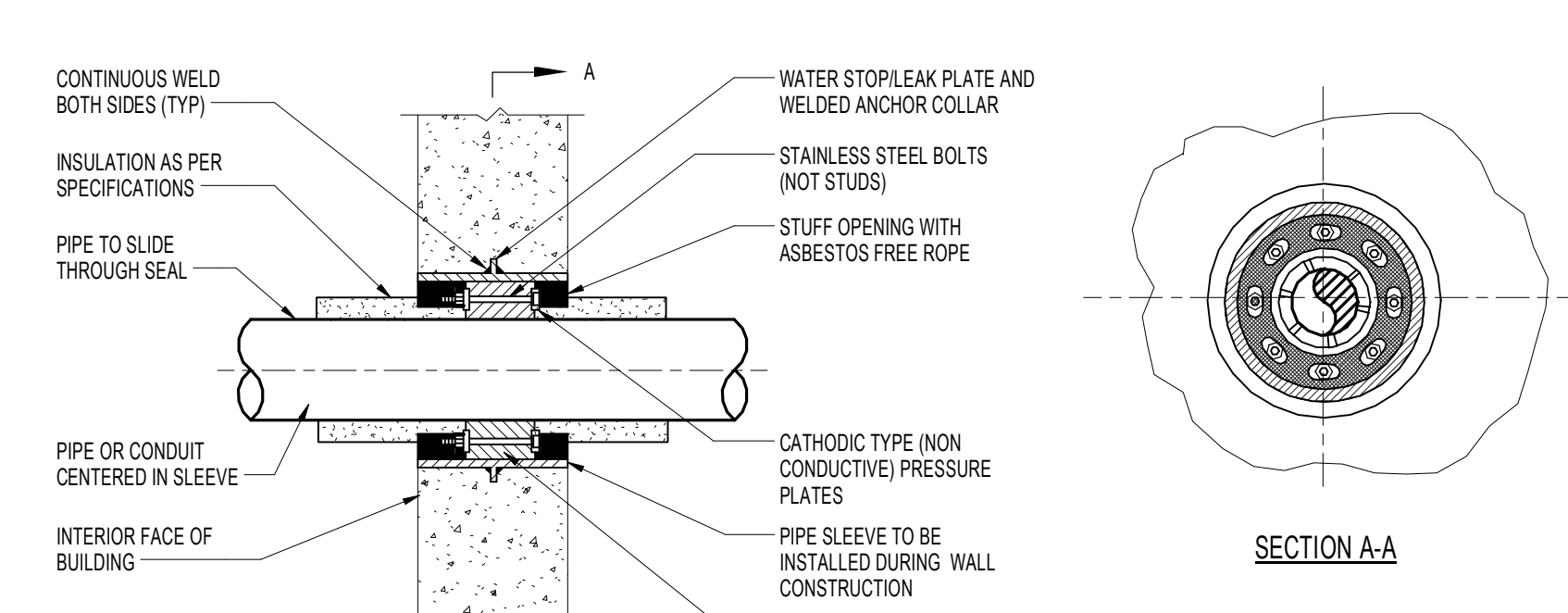

12 MOLDED RUBBER BOLTED SEAL ASSEMBLY
SCALE: NTS

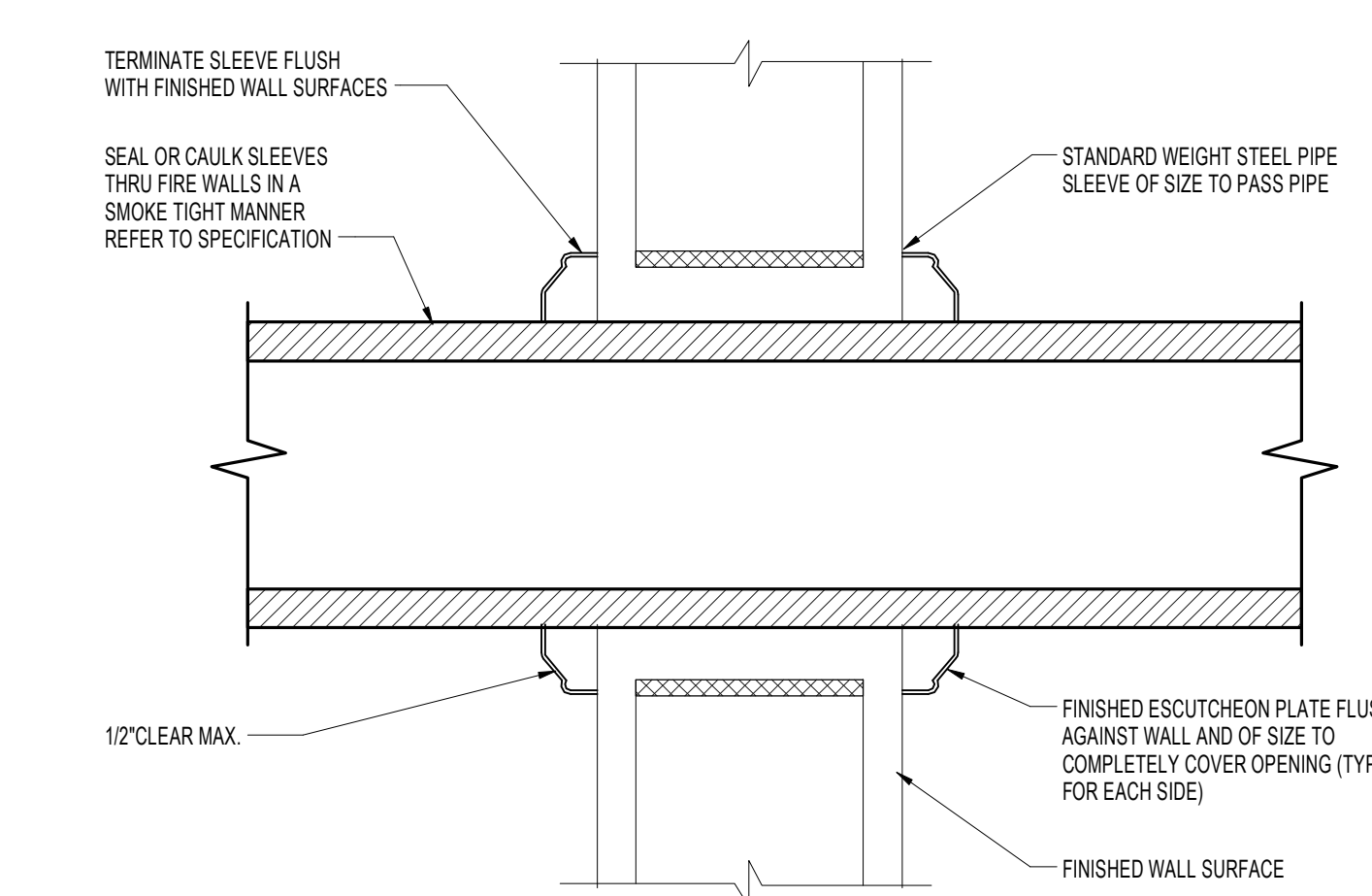

13 TYPICAL PIPE THRU RATED WALL
SCALE: NTS

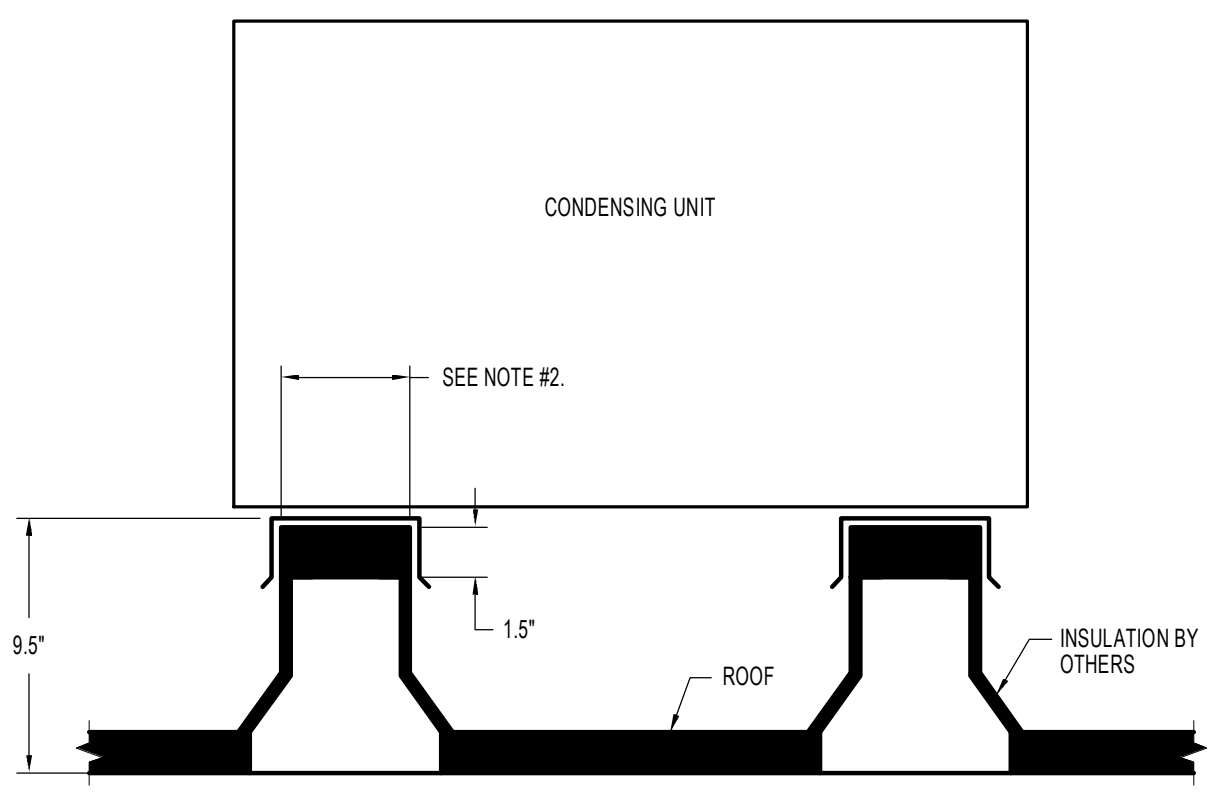

14 CONDENSING UNIT CURB DETAIL
SCALE: NTS

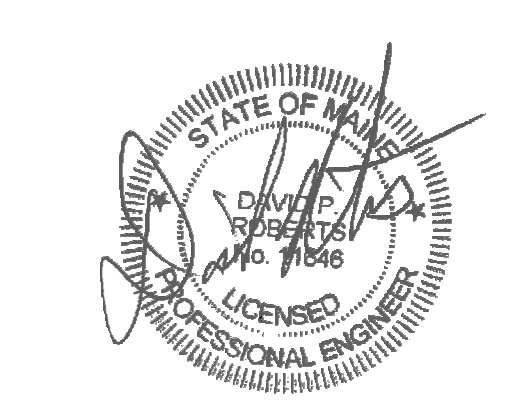
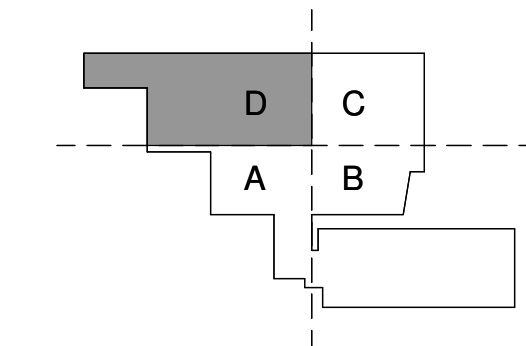

Revisions

ISSUED FOR PERMIT	08.21.2015
ADDENDUM 1	08.21.2015
NO.	DATE
Sheet Information	
Date	JULY 31, 2015
Job #	B150155-000
Drawn	TU
Checked	DPR
Approved	DPR
Title	

**MECHANICAL
DETAILS**

Sheet
M05-00