

Revisions

ISSUED FOR PERMIT	05/08/15
1 ADDENDUM NO. 1	05/22/15
NO	DATE
ISSUE	DATE
Sheet Information	
Date	MAY 1, 2015
Job Number	152168.009
Drawn	Author
Checked	sc
Approved	Approver
Title	
INTERIOR ELEVATIONS	
Sheet	
A10-11	
Copyright © 2015 Perkins+Will	

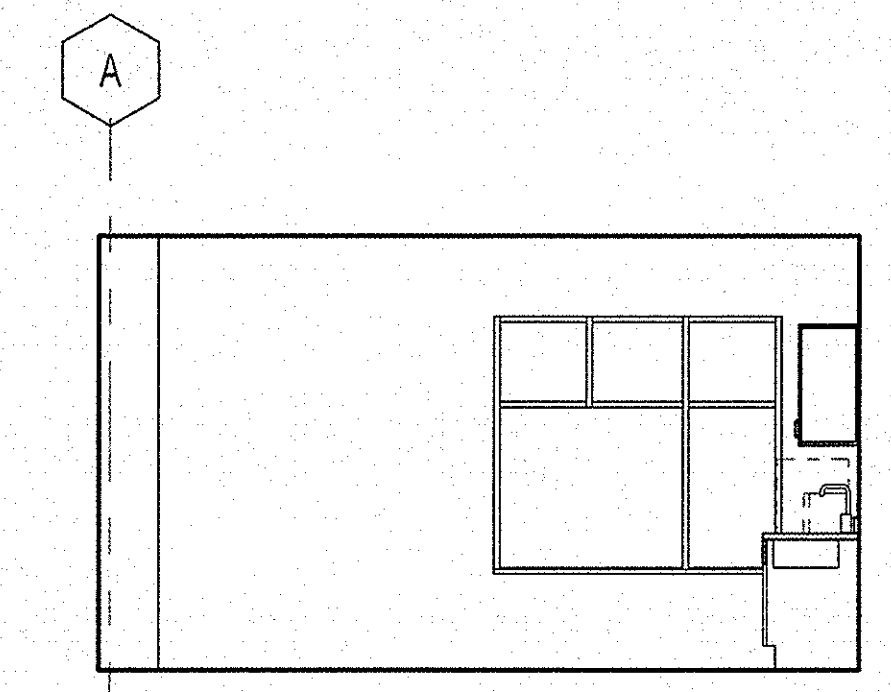

E1 STAFF LOUNGE #2025 - WEST
1/4" = 1'-0"

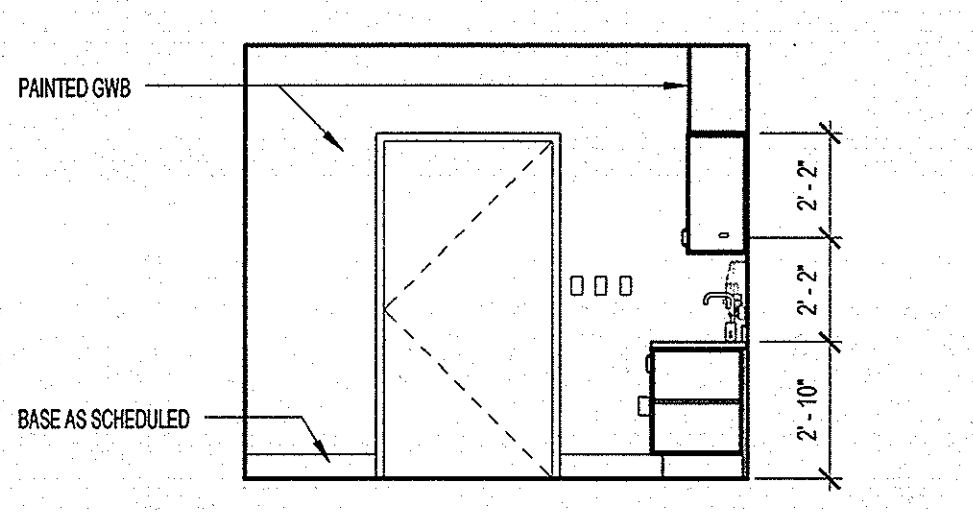

D1 TREATMENT - WEST WALL
1/4" = 1'-0"

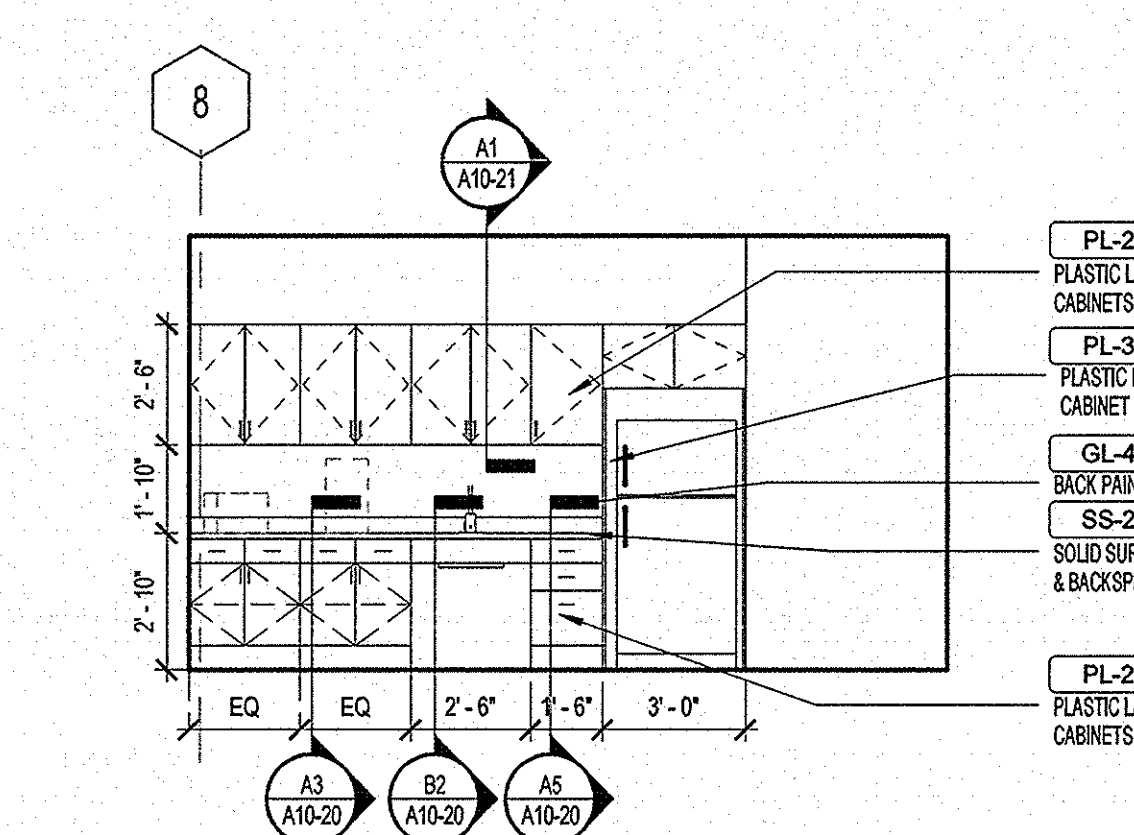

E2 STAFF LOUNGE #2025 - SOUTH
1/4" = 1'-0"

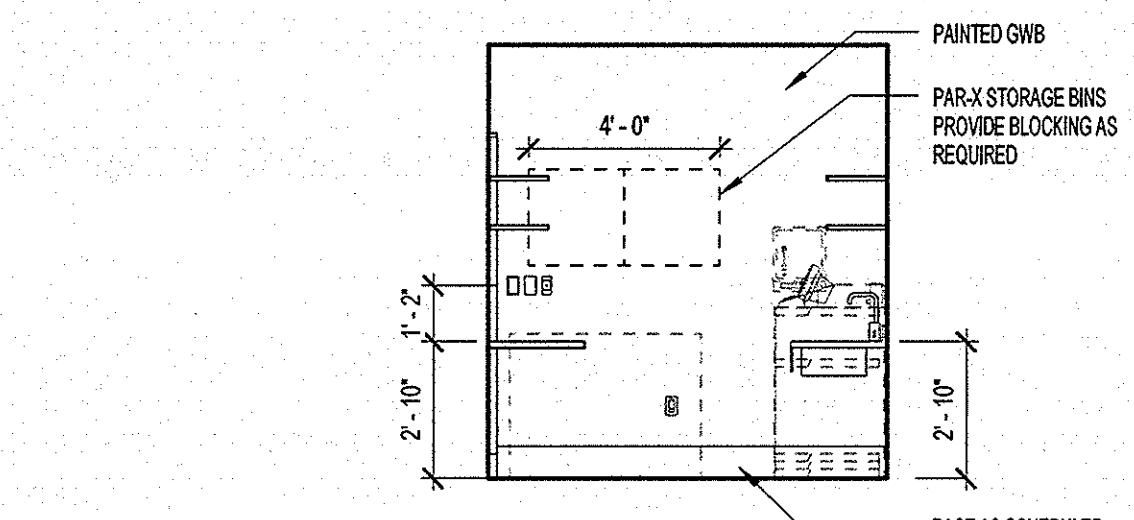

D2 MEDS - NORTH WALL
1/4" = 1'-0"

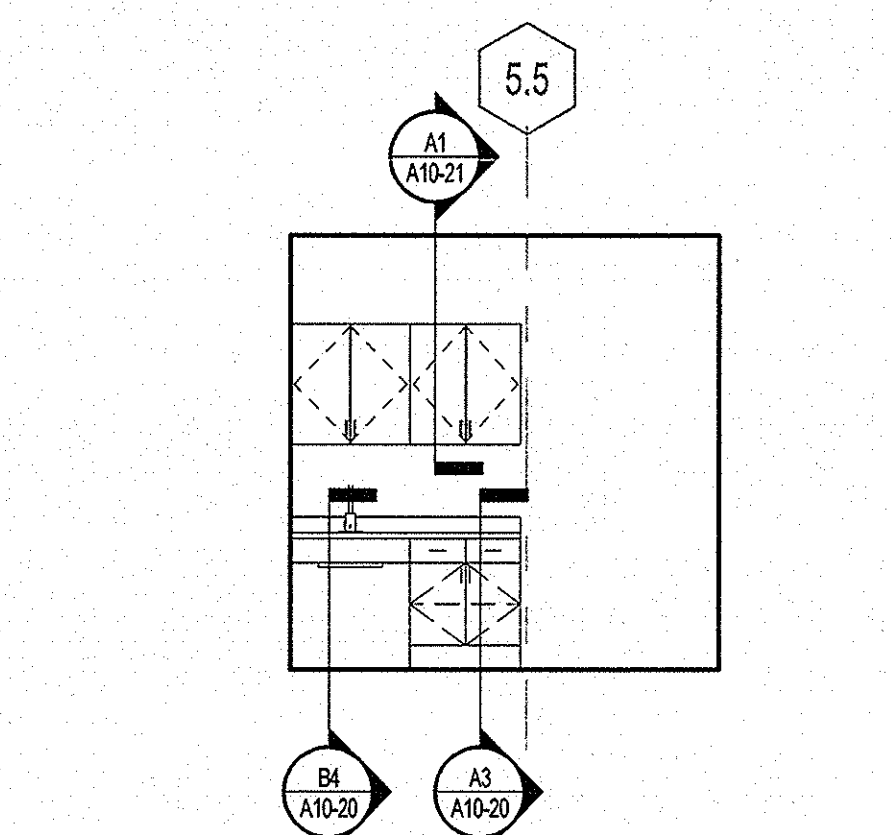

E3 LAB #6054A - SOUTH
1/4" = 1'-0"

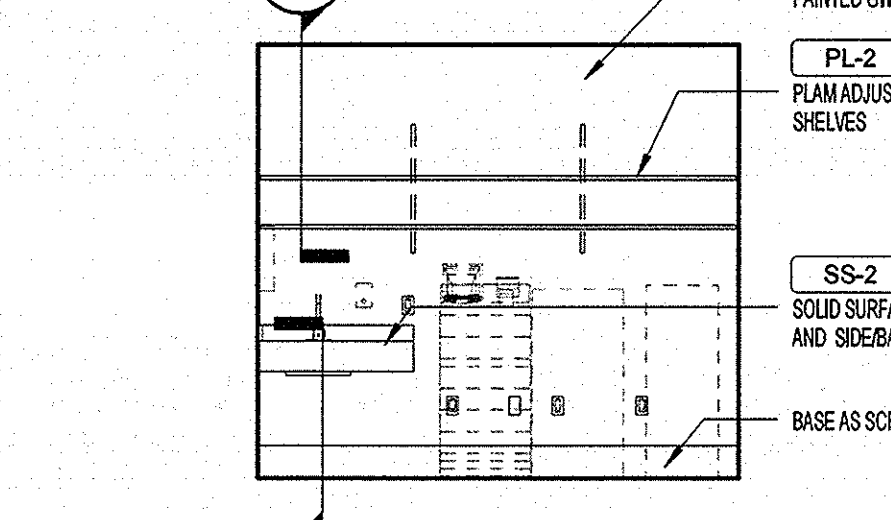

D3 MEDS - EAST WALL
1/4" = 1'-0"

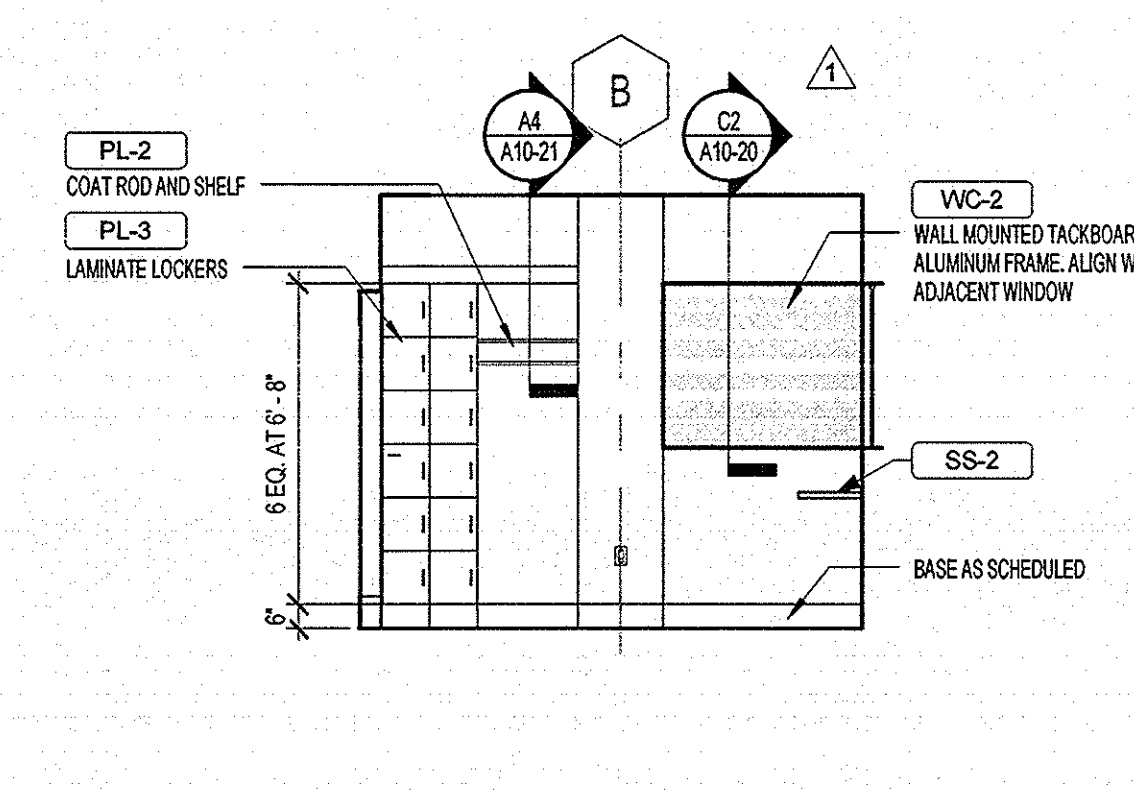

C2 STAFF LOUNGE - EAST
1/4" = 1'-0"

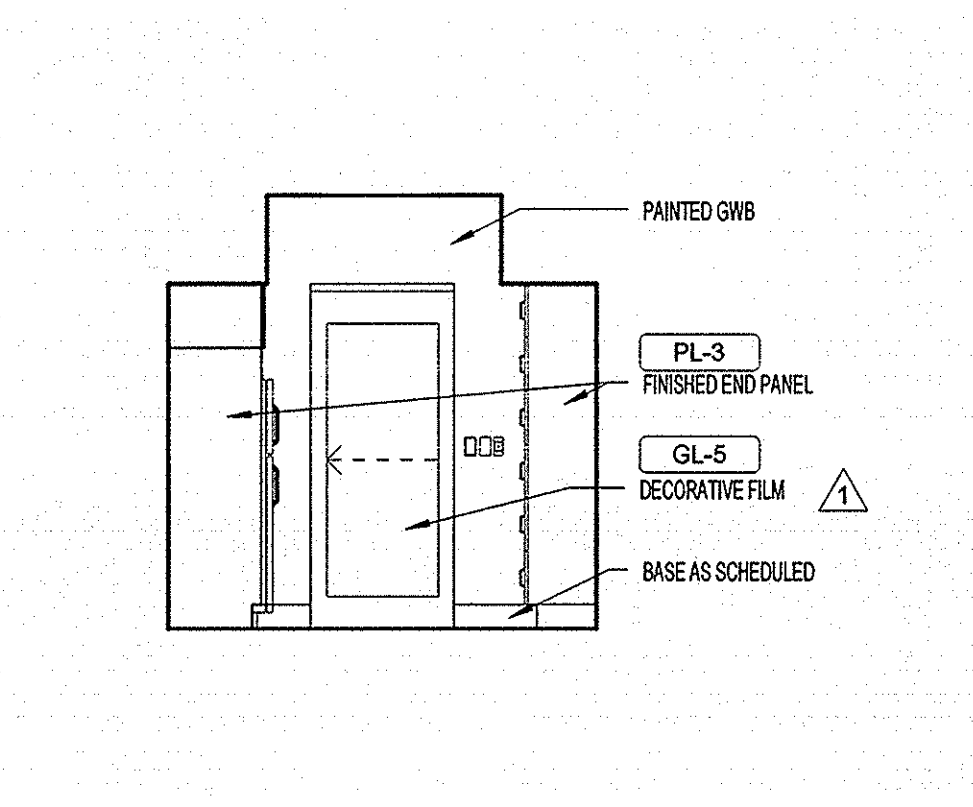

C1 STAFF LOUNGE - NORTH
1/4" = 1'-0"

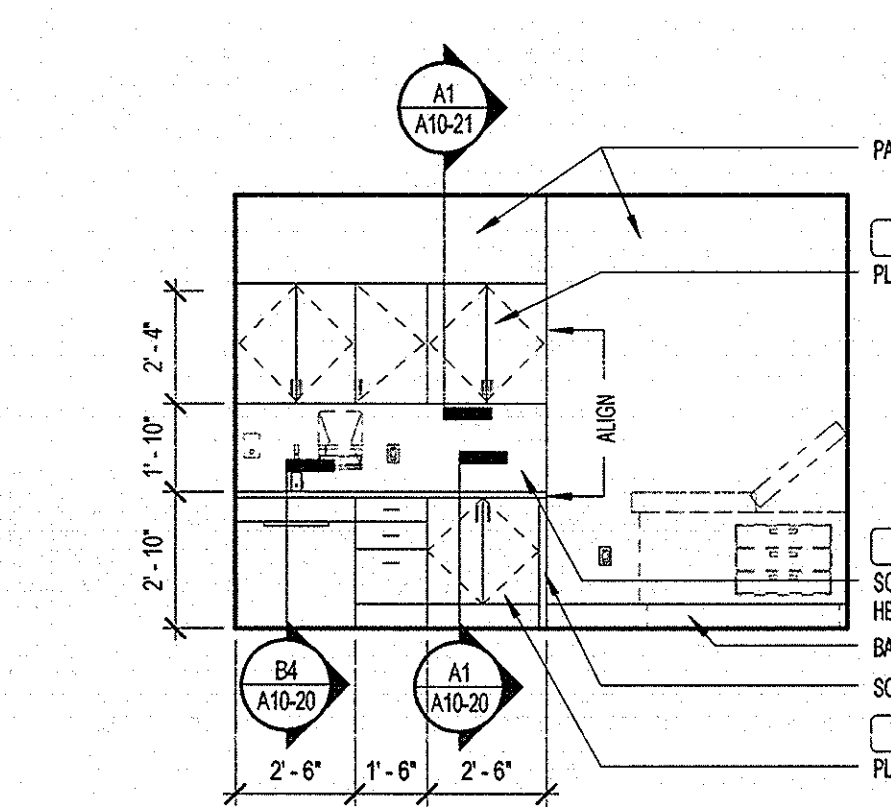

C3 TREATMENT - NORTH WALL
1/4" = 1'-0"

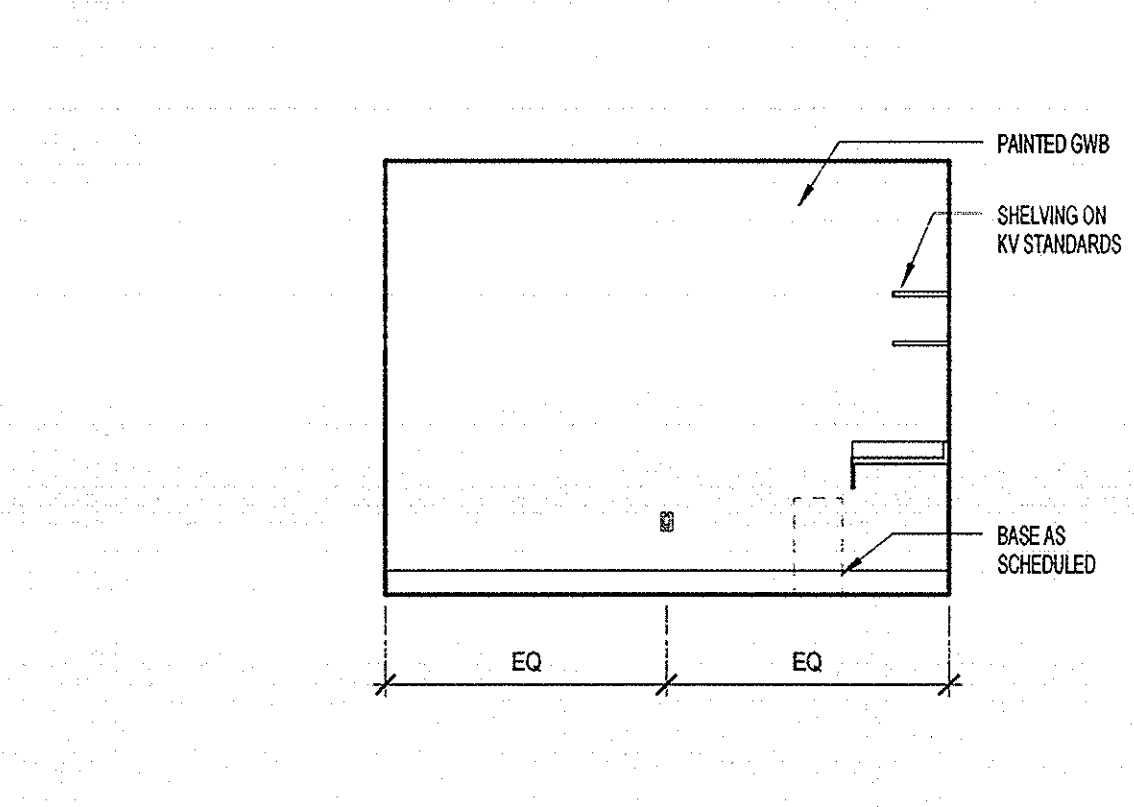

B2 SOILED - WEST WALL
1/4" = 1'-0"

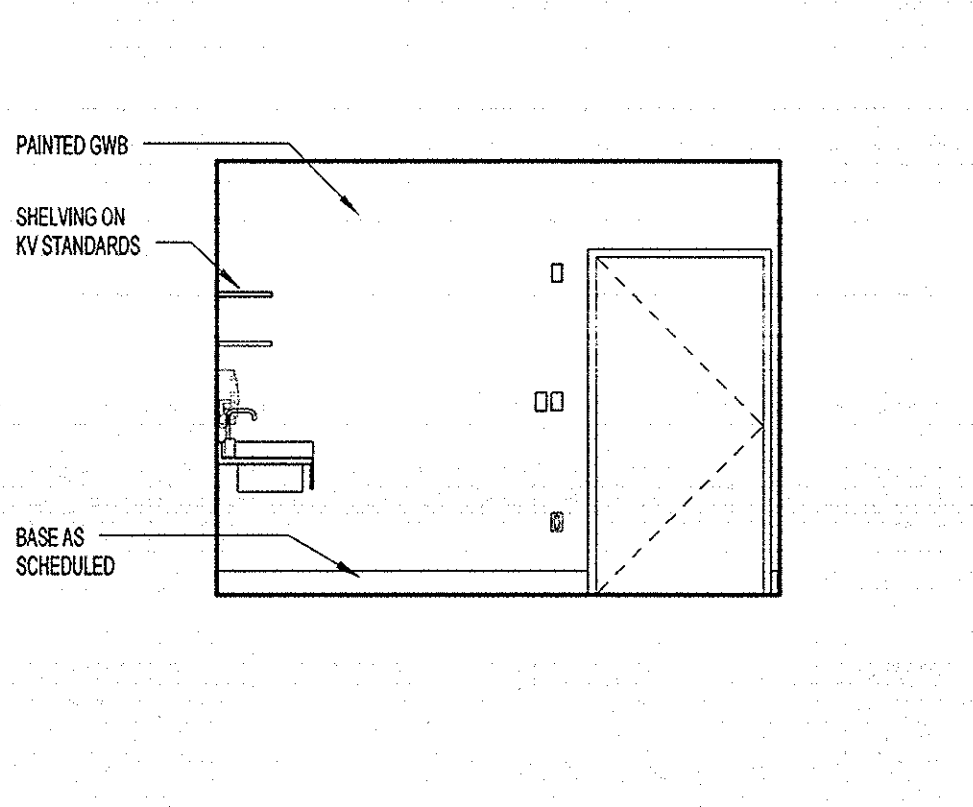

B1 SOILED - EAST WALL
1/4" = 1'-0"

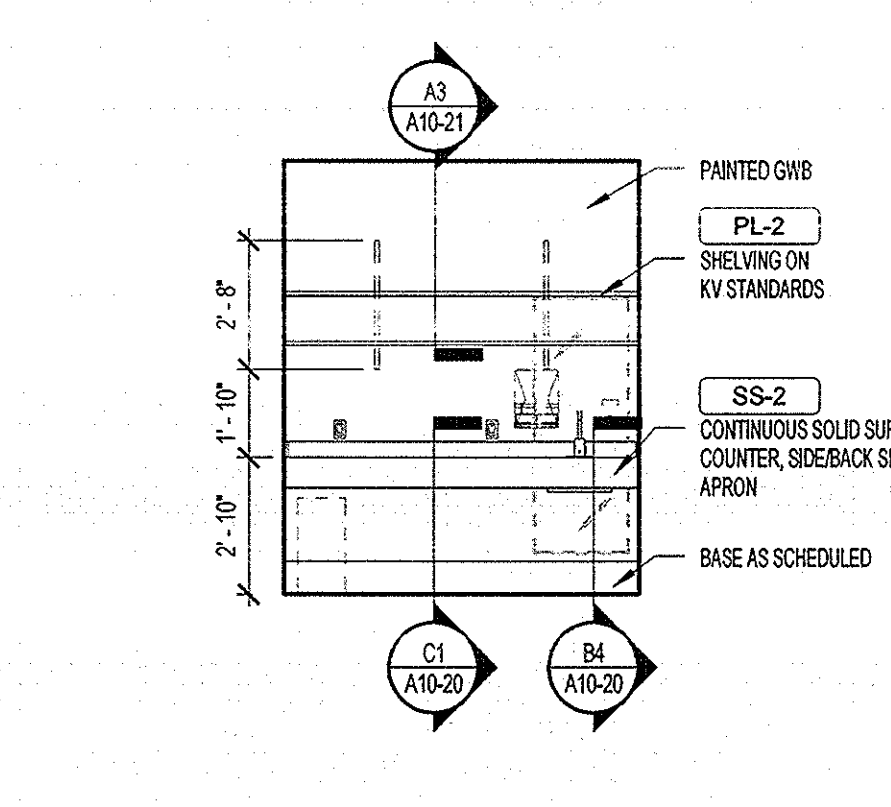

B3 SOILED - NORTH WALL
1/4" = 1'-0"

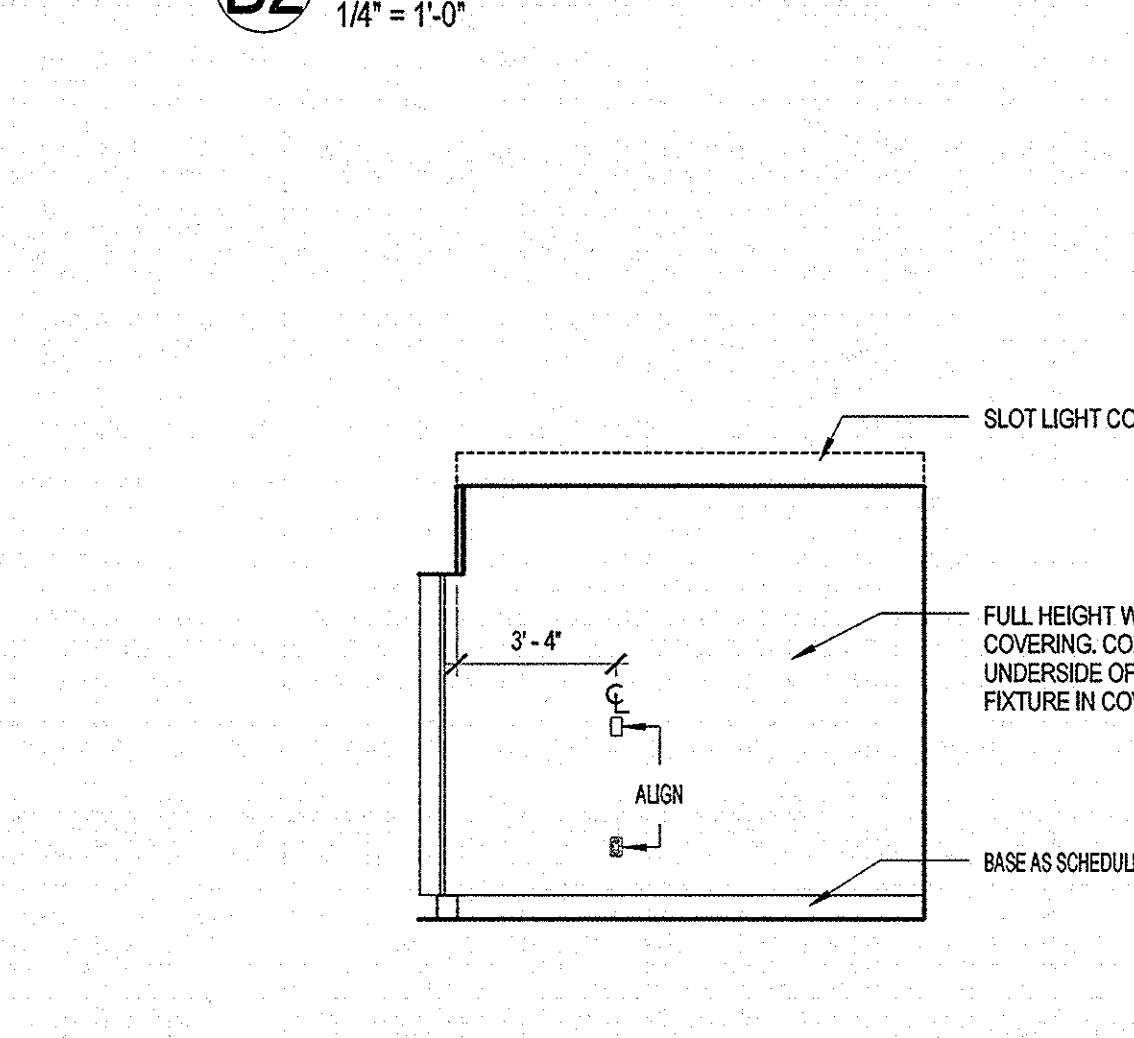

A2 CONSULTATION - EAST WALL
1/4" = 1'-0"

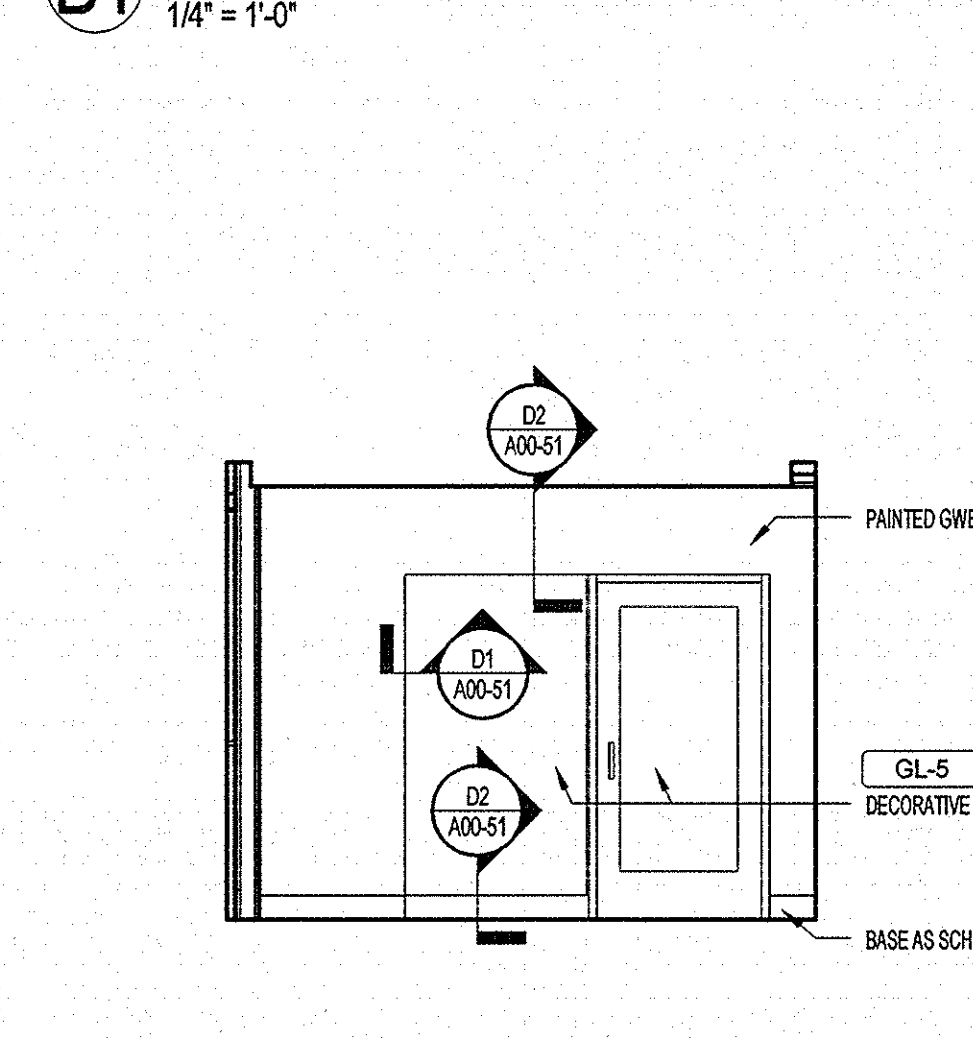

A1 CONSULTATION - ENTRY WALL
1/4" = 1'-0"



D4 MEDS - SOUTH WALL
1/4" = 1'-0"

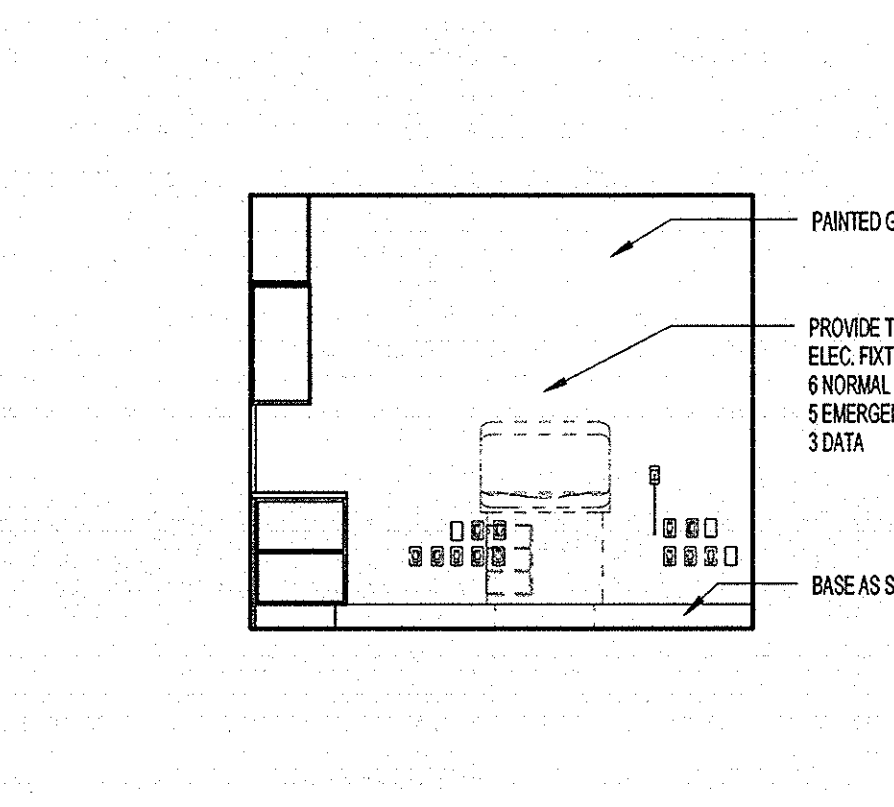

C4 TREATMENT - EAST WALL
1/4" = 1'-0"



D5 MEDS - WEST WALL
1/4" = 1'-0"

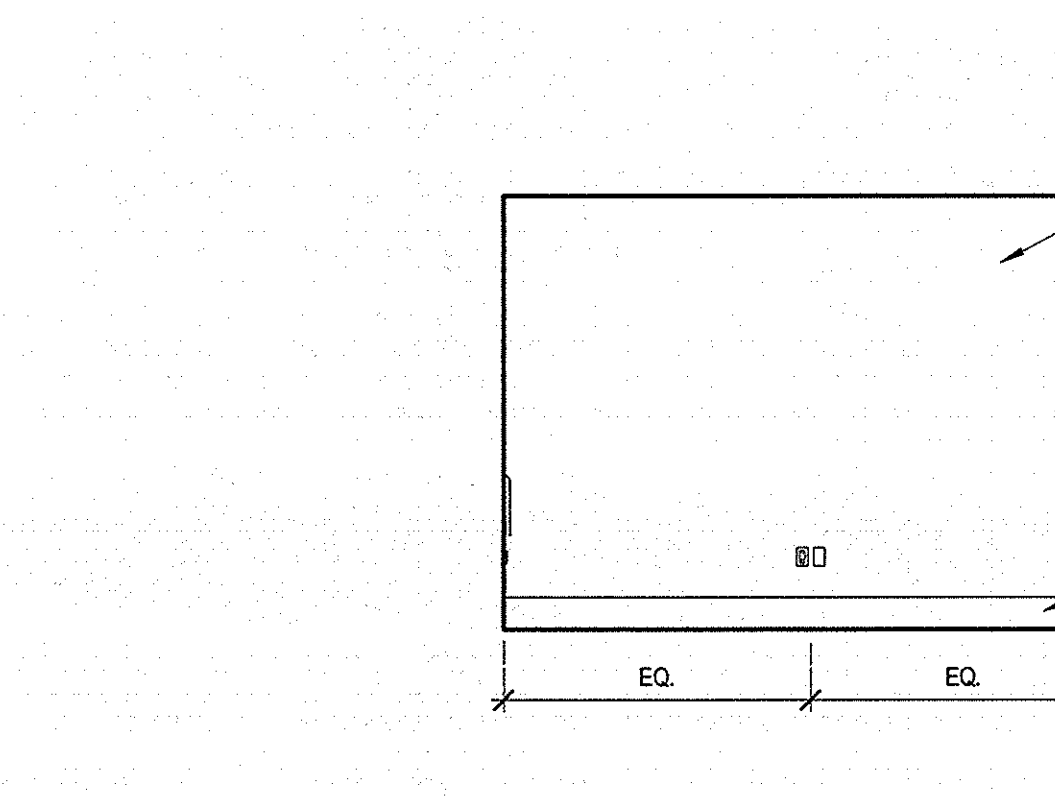

C5 TREATMENT - SOUTH WALL
1/4" = 1'-0"

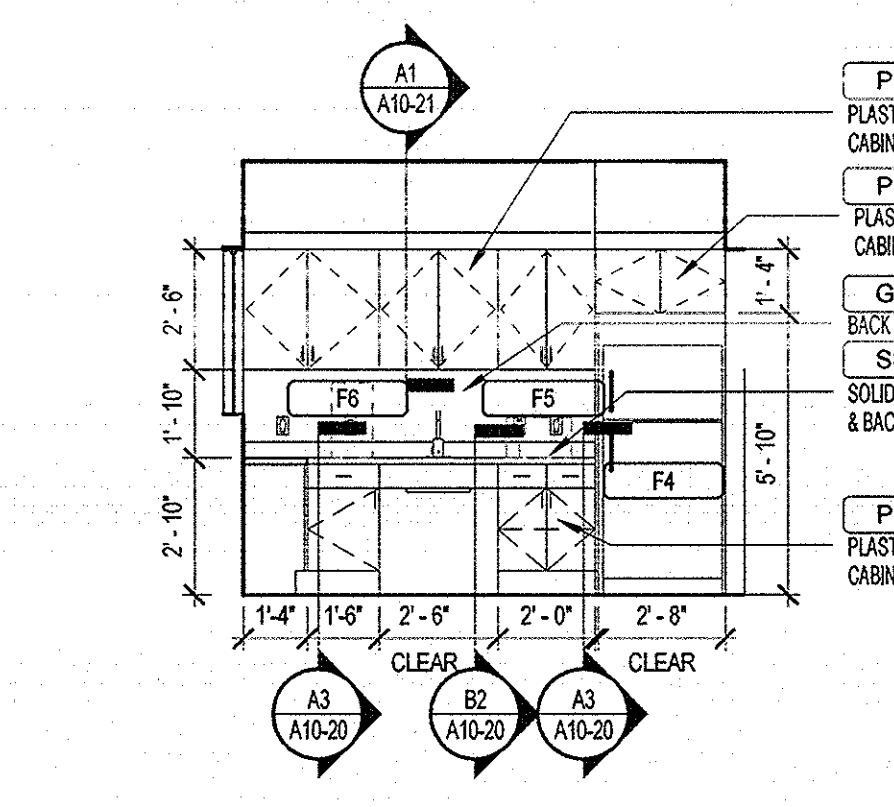

B4 STAFF LOUNGE - WEST
1/4" = 1'-0"

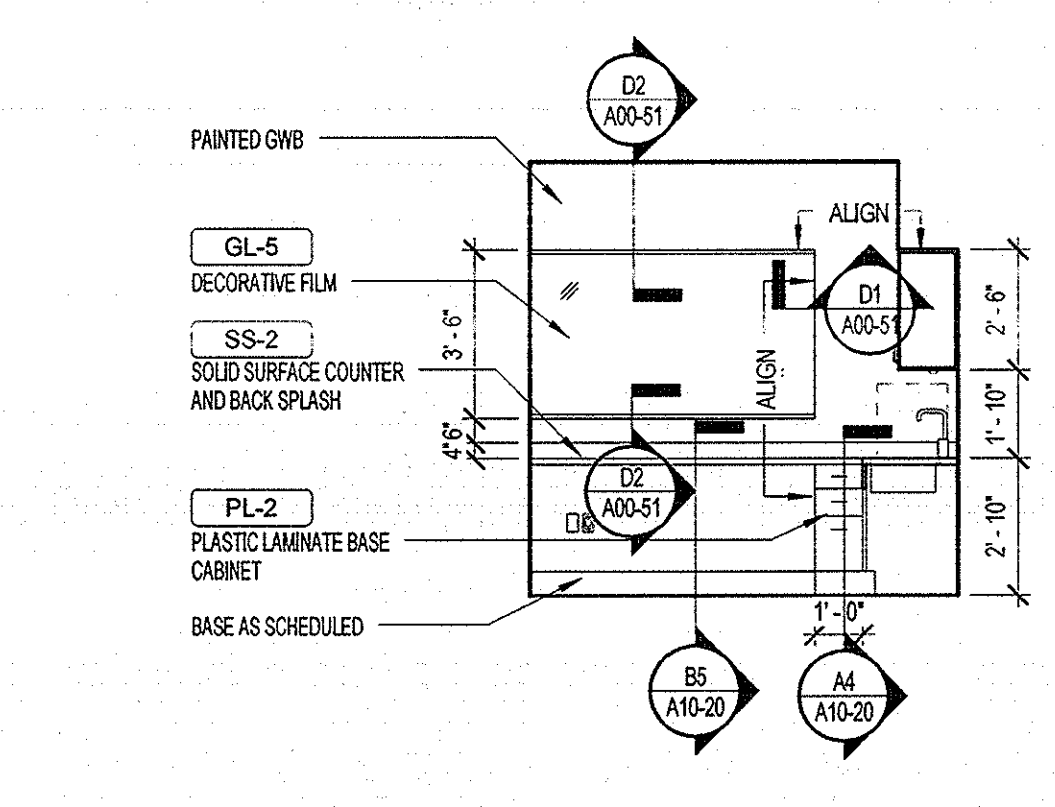

B5 STAFF LOUNGE - SOUTH
1/4" = 1'-0"

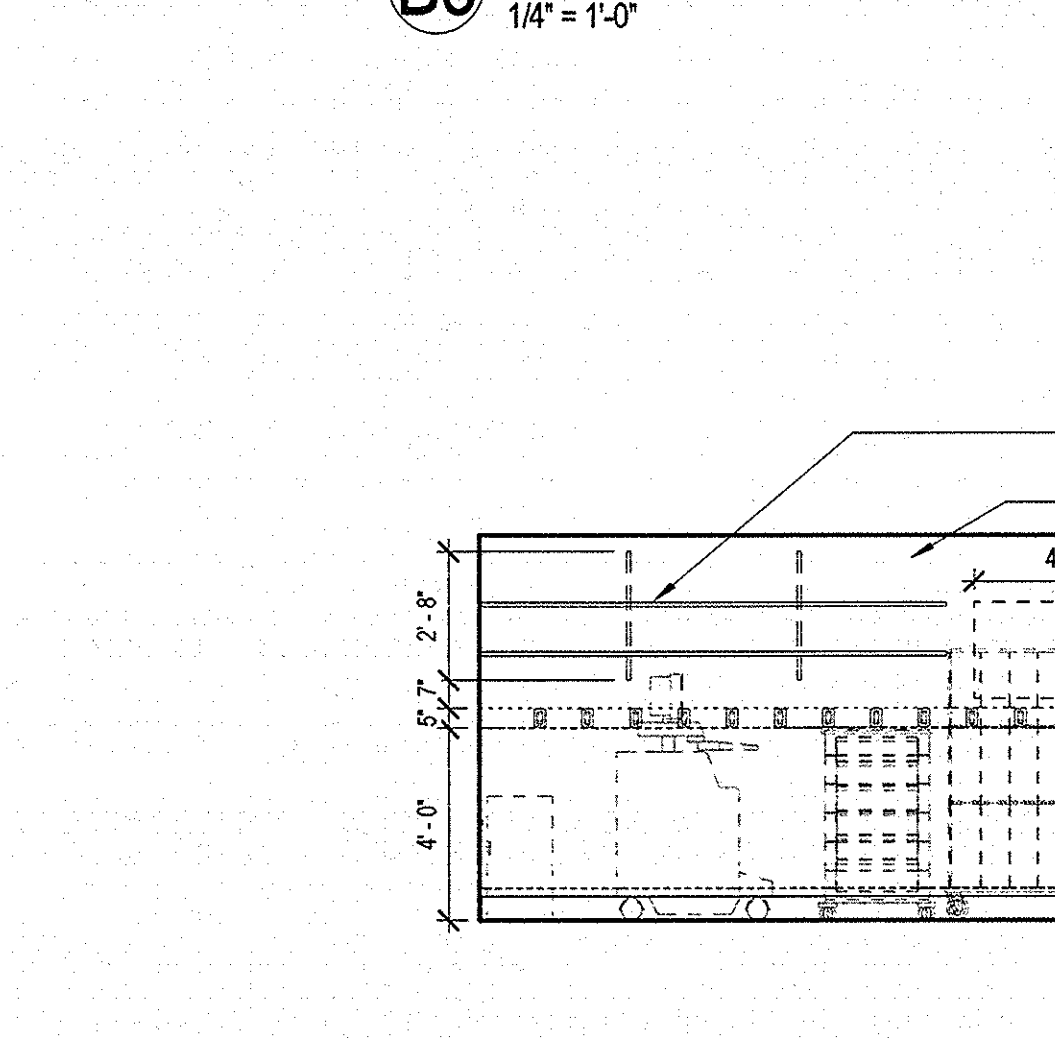

A5 CLEAN SUPPLY - EAST WALL
1/4" = 1'-0"

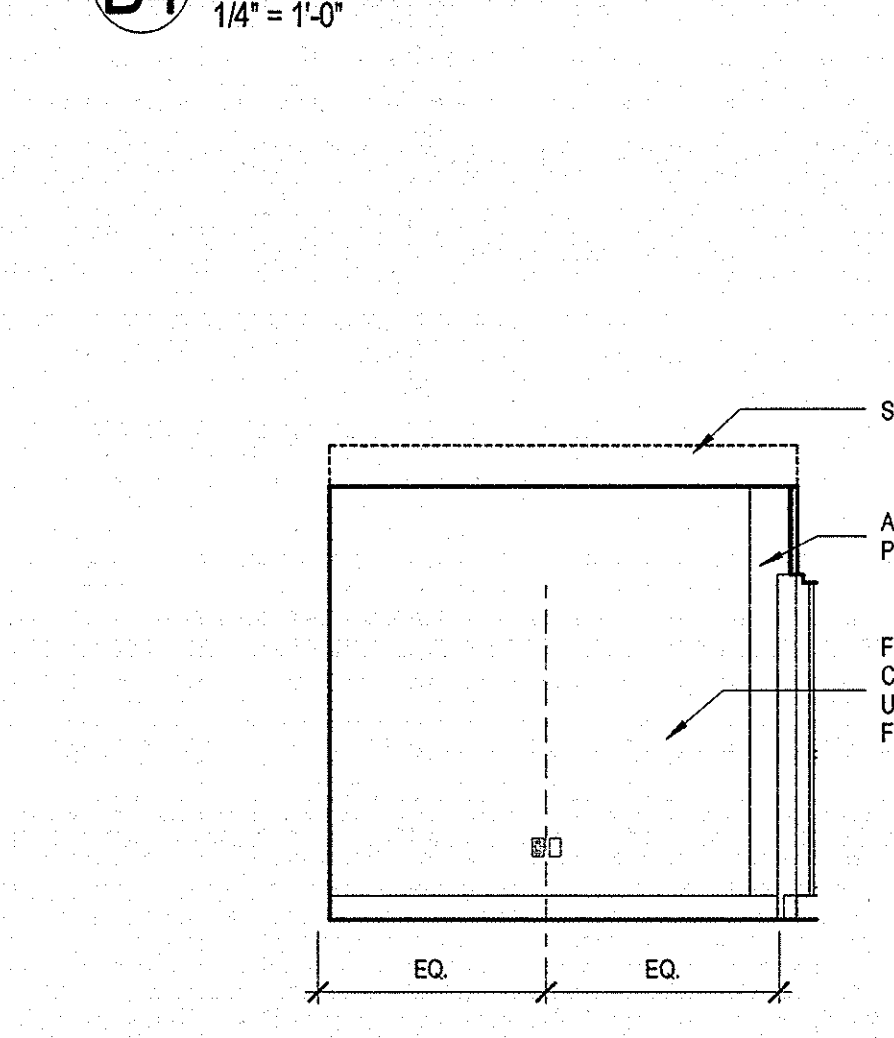

A4 CONSULTATION - WEST WALL
1/4" = 1'-0"

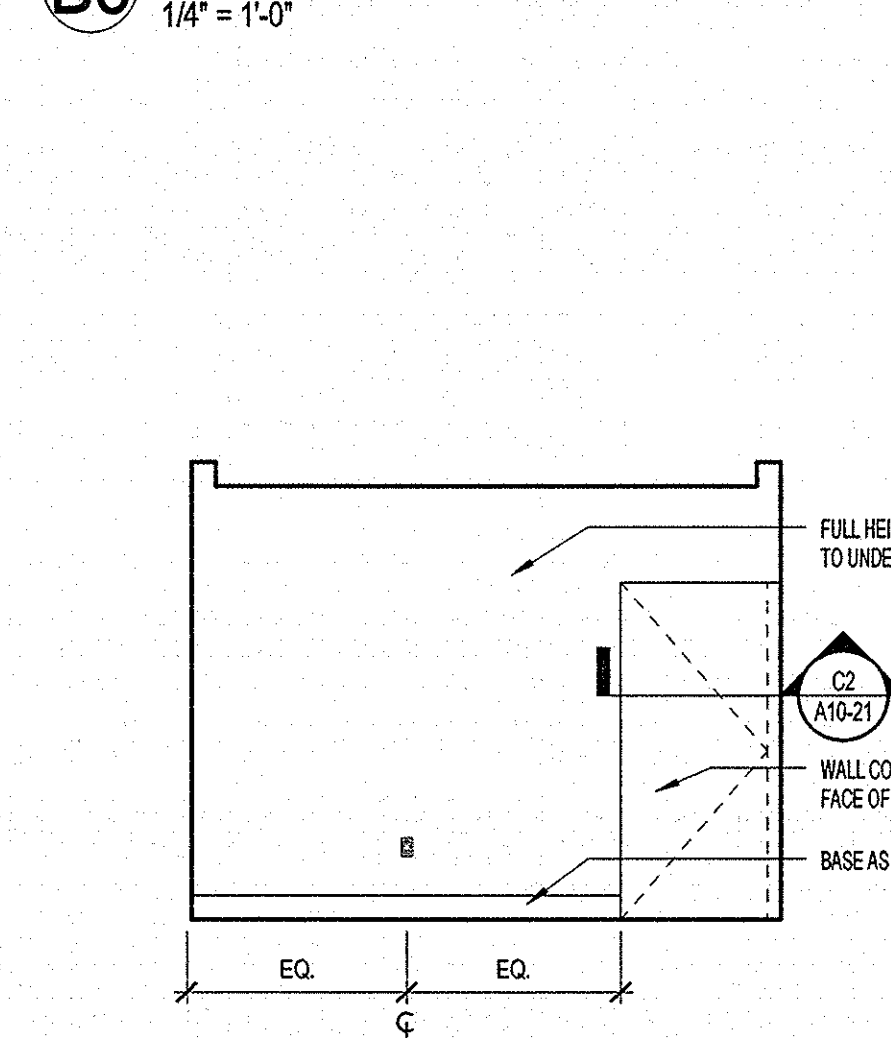

A3 CONSULTATION - SOUTH WALL
1/4" = 1'-0"

6/4/2015 5:56:02 PM
c:\p1152168.009 MMC_PICU_baimes.rvt