

PERKINS + WILL

225 Franklin St., Suite 1100
Boston, MA 02110
1 617 438 0300
1 617 478 0321
www.perkinswill.com

Maine Medical Center
MaineHealth

Bean 2 Roof
Addition
22 Bramhall Street, Portland,
Maine 04102

MEP ENGINEER
AKF ENGINEERS
41 Farnsworth Street, 3rd Floor
Boston, MA 02210
1 617 737 1111
1 617 737 4311

STRUCTURAL ENGINEER
SIMPSON GUMPERTZ & HEGER
41 Seyon Street, Building 1, Suite 500
Walham, MA 02453
1 781 907 9000
SGH Project No. 100439.09

MEDICAL EQUIPMENT PLANNERS
RTKL ASSOCIATES INC.
1717 PACIFIC AVENUE
DALLAS, TX 75201
1 214 468 7000
1 214 468 7601

COST ESTIMATOR
DG JONES & PARTNERS
3 Baldwin Green Common, Suite 202
Woburn, MA 01801
1 781 932 3131
1 781 932 3199

CONSTRUCTION DOCUMENTS
06.14.2013

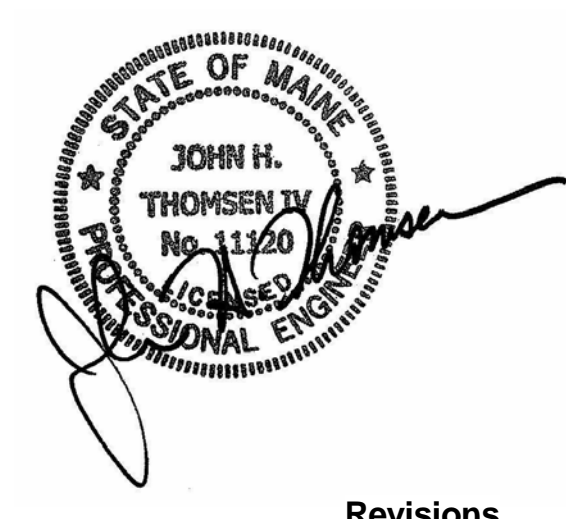
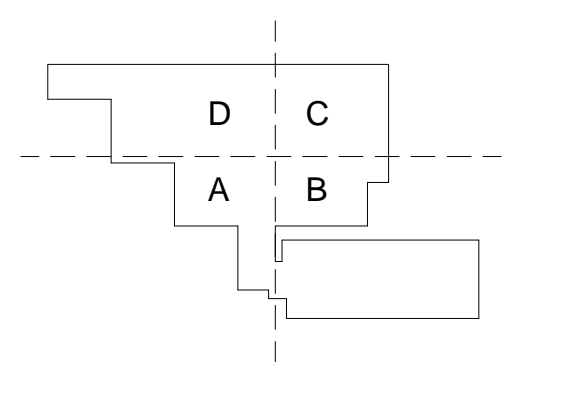

Revisions

NO.	ISSUE	DATE
1	ISSUED FOR PERMIT	02/07/14
2	ADDENDUM #1	06/14/13

Sheet Information
Date: 12 APRIL 2013
Job #: C140135461(MMC)152168.000
Drawn: BMT/SWW
Checked: MJB
Approved: JHT

STEEL DETAILS - LEVEL 04 PENTHOUSE

Sheet
S07-01

Copyright © 2011 Perkins+Will

2/7/2014 3:44:01 PM I:\BOS\Projects\2010100439.09-2065ED\Drawings\Working_Seri_Revit\LOCAL USERS\MJC\addendum\MC_BEAN2_NEW_STRUC_A\MBedisc.rvt