

**Bean 2 Roof
Addition**
22 Bramhall Street, Portland,
Maine 04102

MEP ENGINEER
AKF ENGINEERS

41 Farnsworth Street, 3rd Floor
Boston, MA 02210
1 617 737 1111
1 617 737 4311

STRUCTURAL ENGINEER
**SIMPSON GUMPERTZ &
HEGER**

41 Seyon Street, Building 1, Suite 500
Waltham, MA 02453
1 781 907 9000
SGH Project No. 100439.09

MEDICAL EQUIPMENT PLANNERS
RTL ASSOCIATES INC.

1717 PACIFIC AVENUE
DALLAS, TX 75201
1 214 468 7000
1 214 468 7601

COST ESTIMATOR
DG JONES & PARTNERS

3 Baldwin Green Common, Suite 202
Woburn, MA 01801
1 781 932 3131
1 781 932 3199

**CONSTRUCTION
DOCUMENTS**
06.14.2013

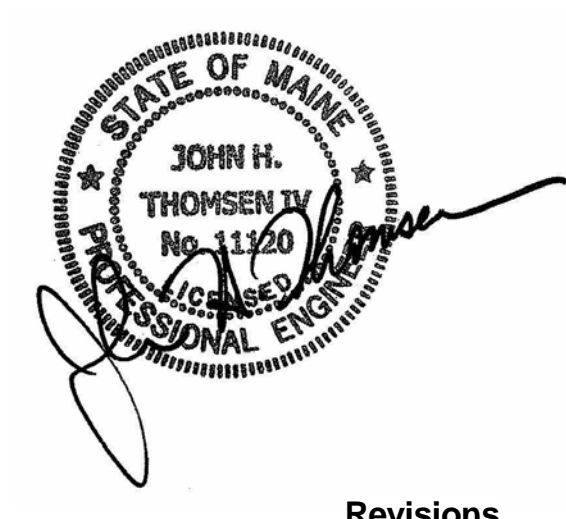
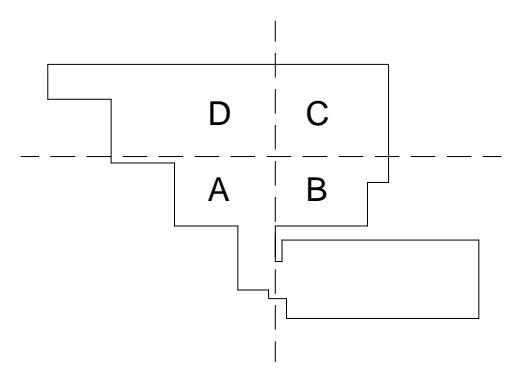

Revisions

NO.	ISSUED FOR PERMIT	DATE
	ISSUE	DATE

Sheet Information

Date	12 APRIL 2013
Job #	C140135461(MMC)152168.000
Drawn	BMT/SWW
Checked	MJB
Approved	JHT
Title	

**STRUCTURAL
AXONOMETRIC**

Sheet
S00-00

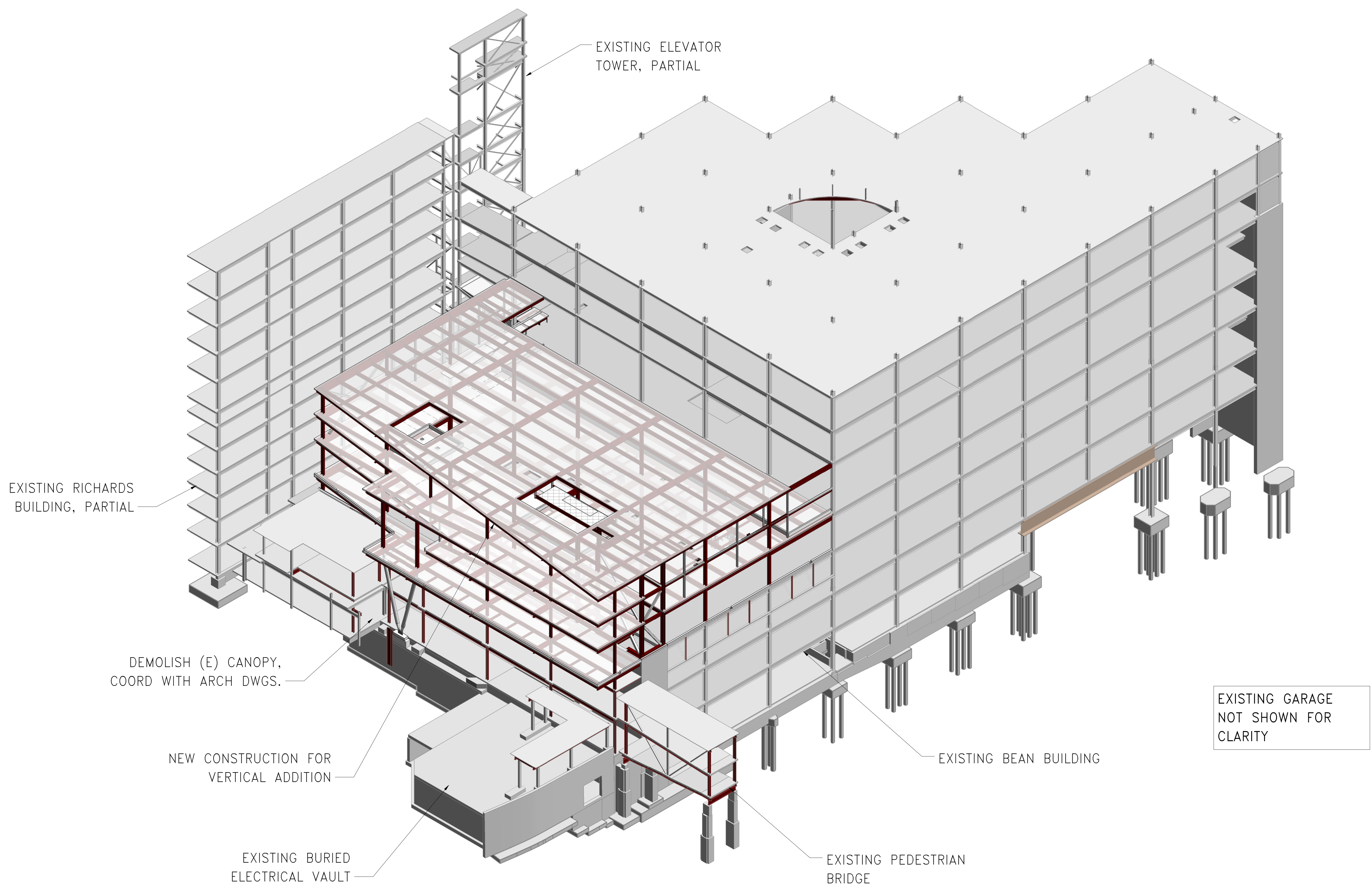

NOTE: RENDERED STRUCTURAL VIEW FOR GENERAL PROJECT SCOPE UNDERSTANDING ONLY.
NOT ALL STRUCTURAL ELEMENTS SHOWN FOR CLARITY.

NORTH FACE
IN AXONOMETRIC