

D5 EXPANSION JOINT AT FLOOR
1 1/2" = 1'-0"

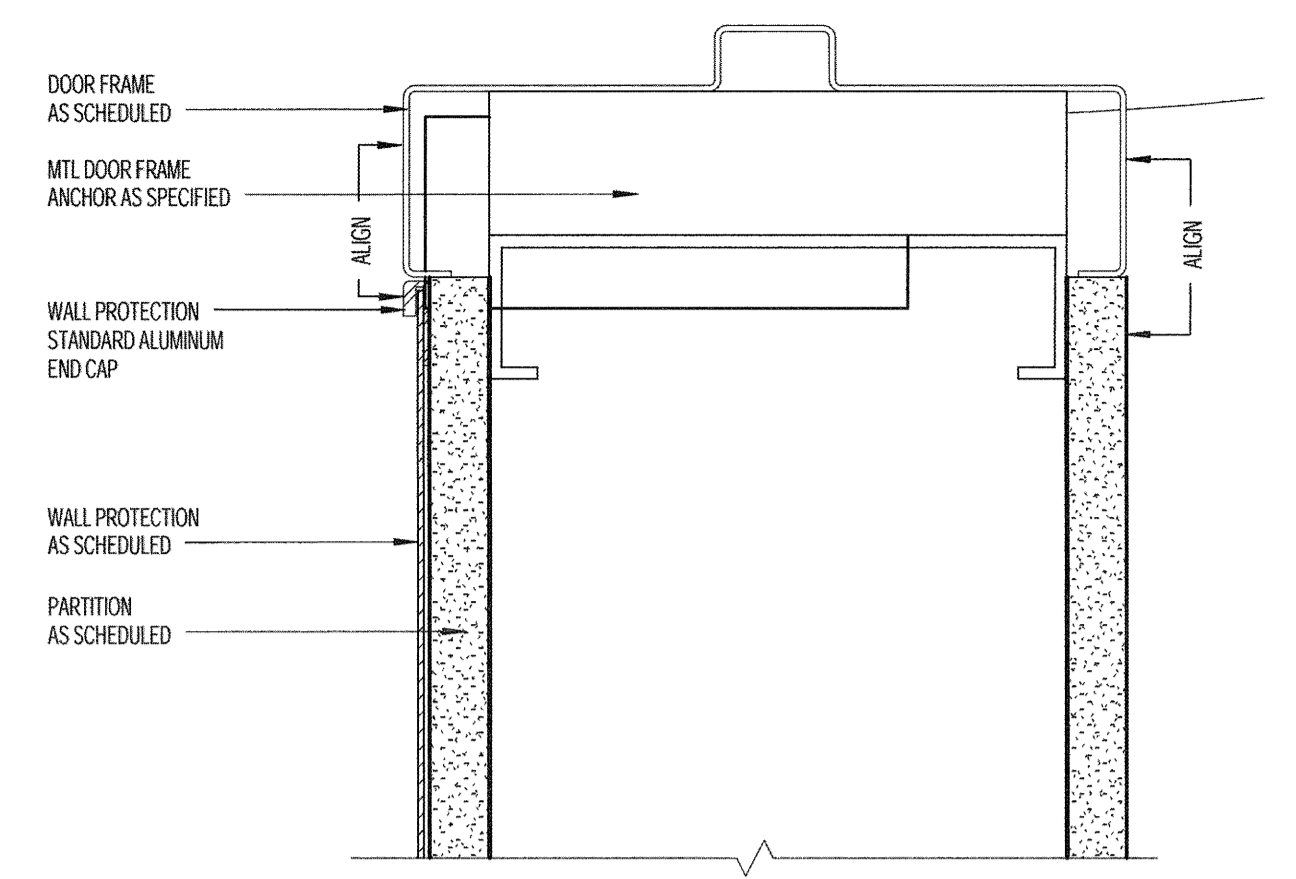

D4 WALL PROTECTION AT WALL JAMB
6" = 1'-0"

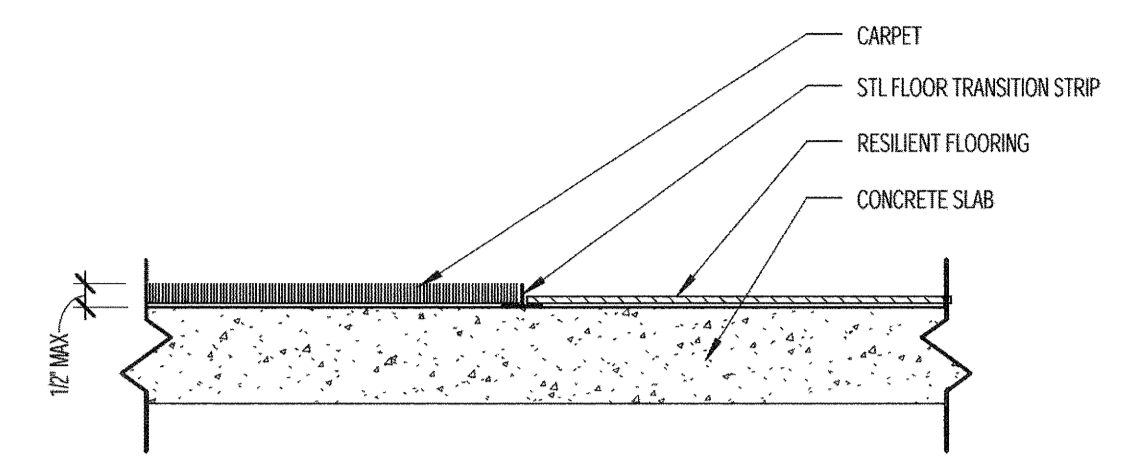

D3 CARPET TO RESILIENT FLOORING
3" = 1'-0"

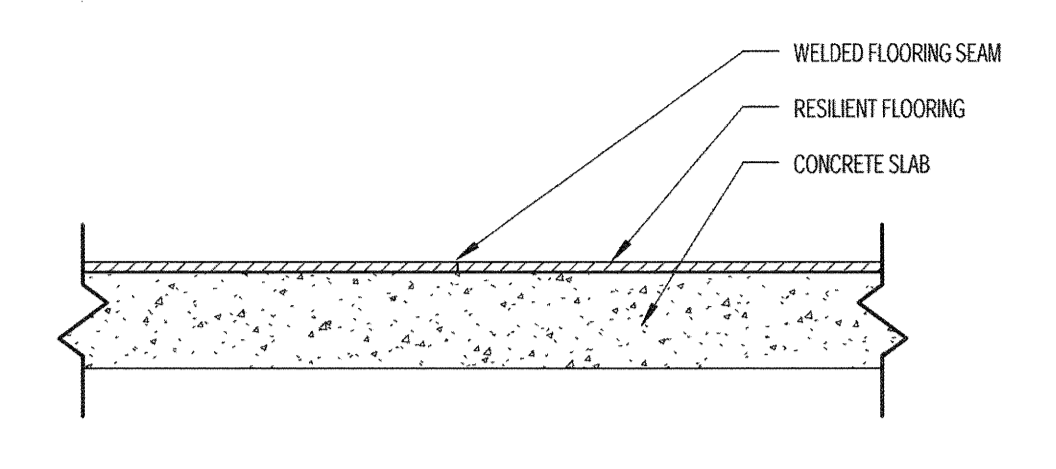

D2 TYPICAL FLOOR TRANSITION RESILIENT TO RESILIENT FLOORING
3" = 1'-0"

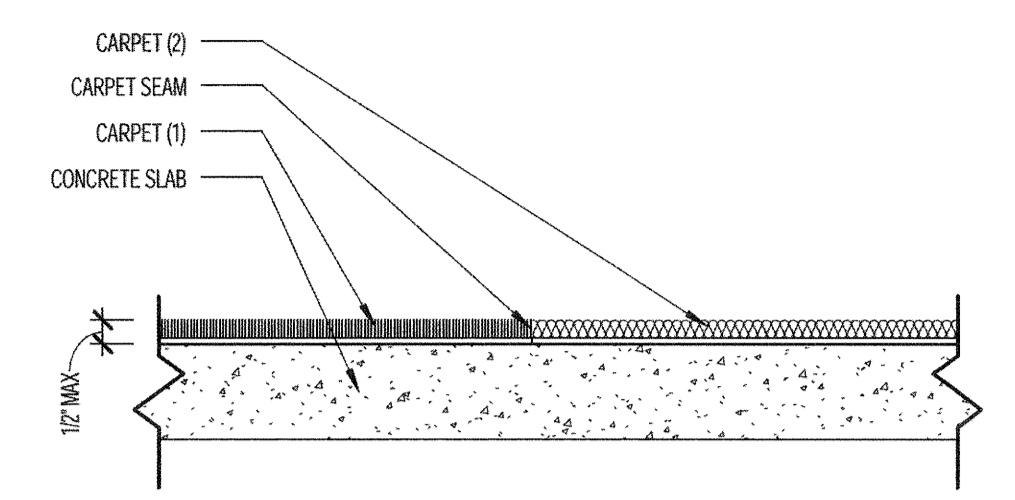

D1 TYPICAL FLOOR TRANSITION CARPET TO CARPET
3" = 1'-0"

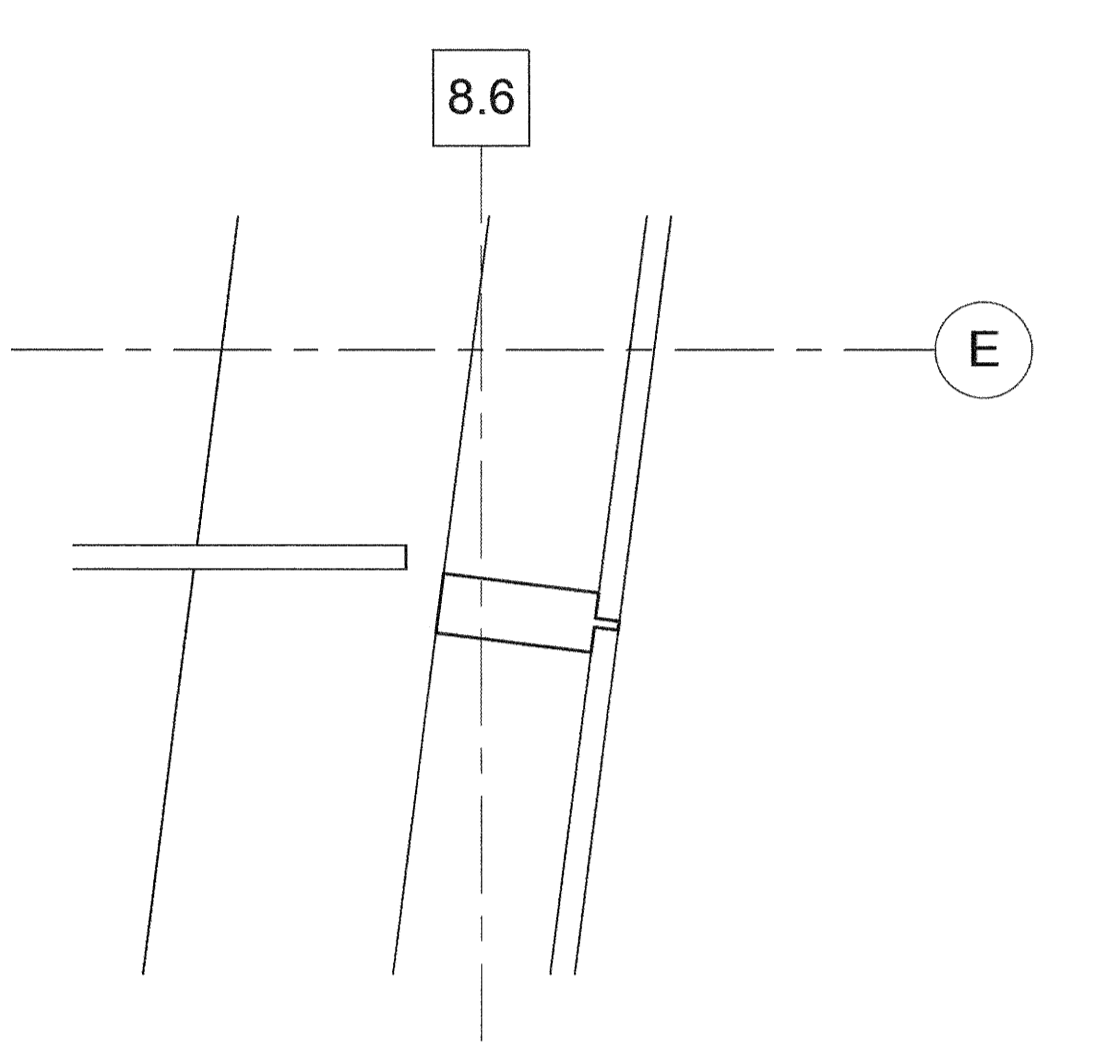

C5 INTERIOR GLAZING @ NEW MULLION
1 1/2" = 1'-0"

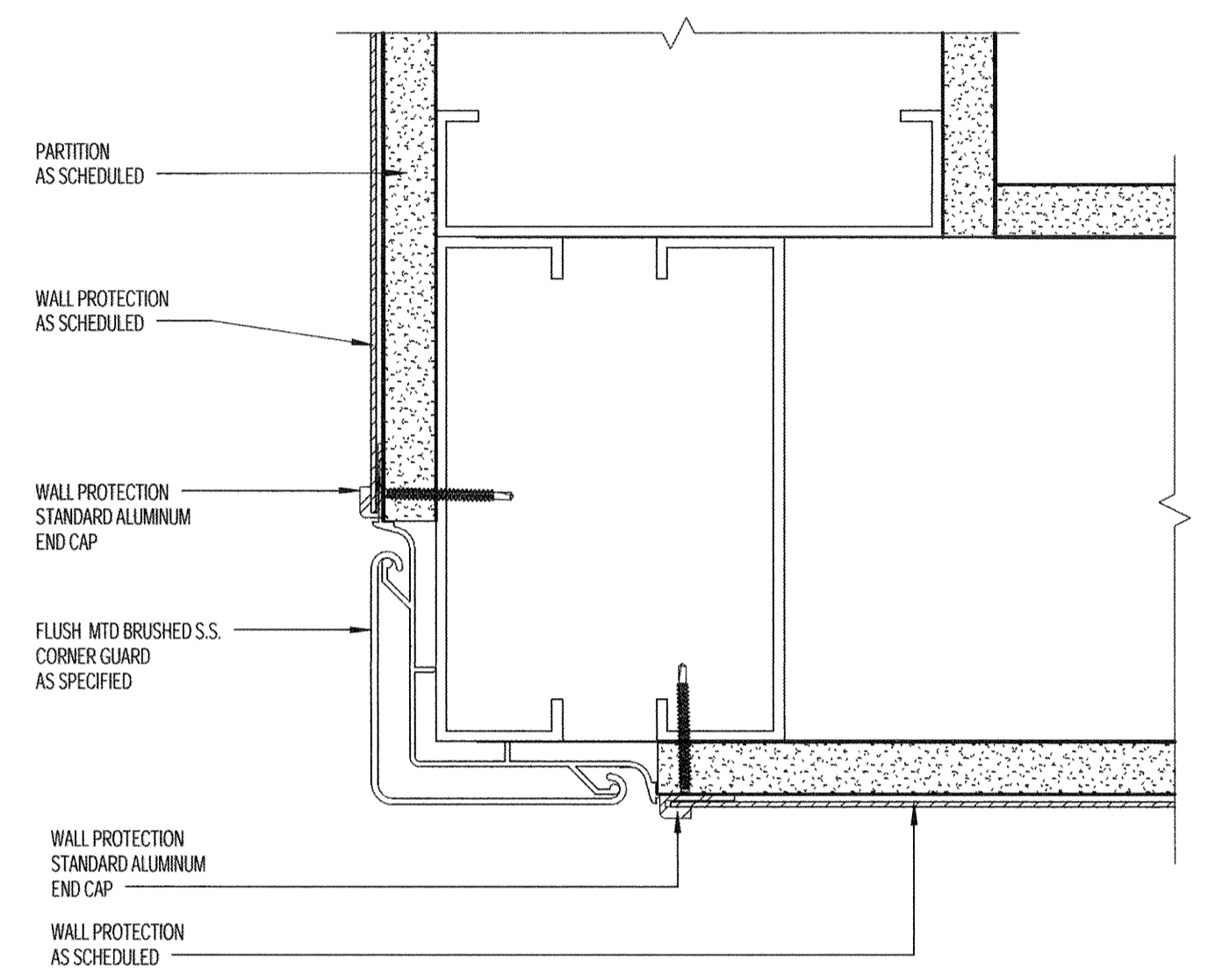

C4 WALL PROTECTION AT CORNER
6" = 1'-0"

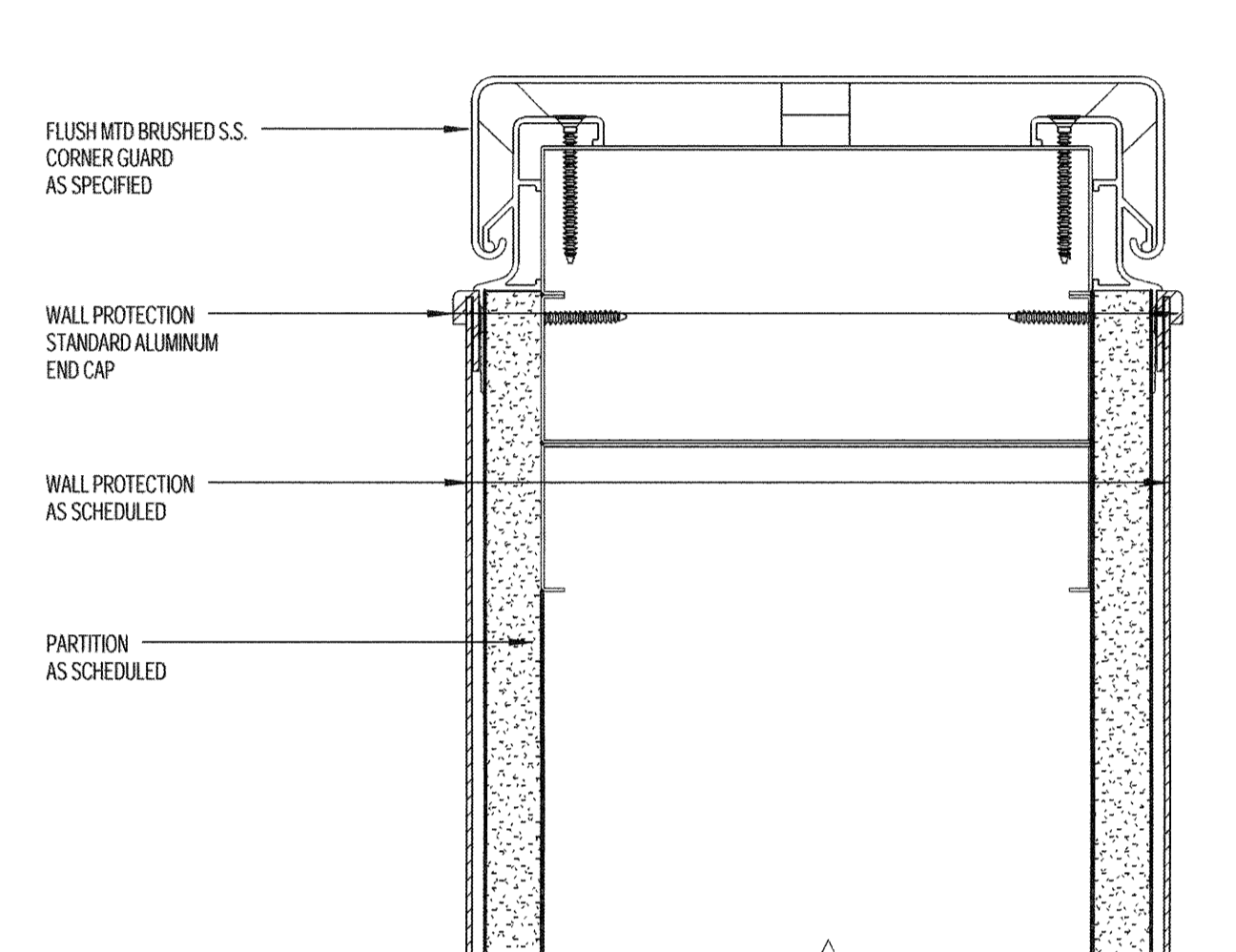

C3 WALL PROTECTION AT END OF WALL
6" = 1'-0"

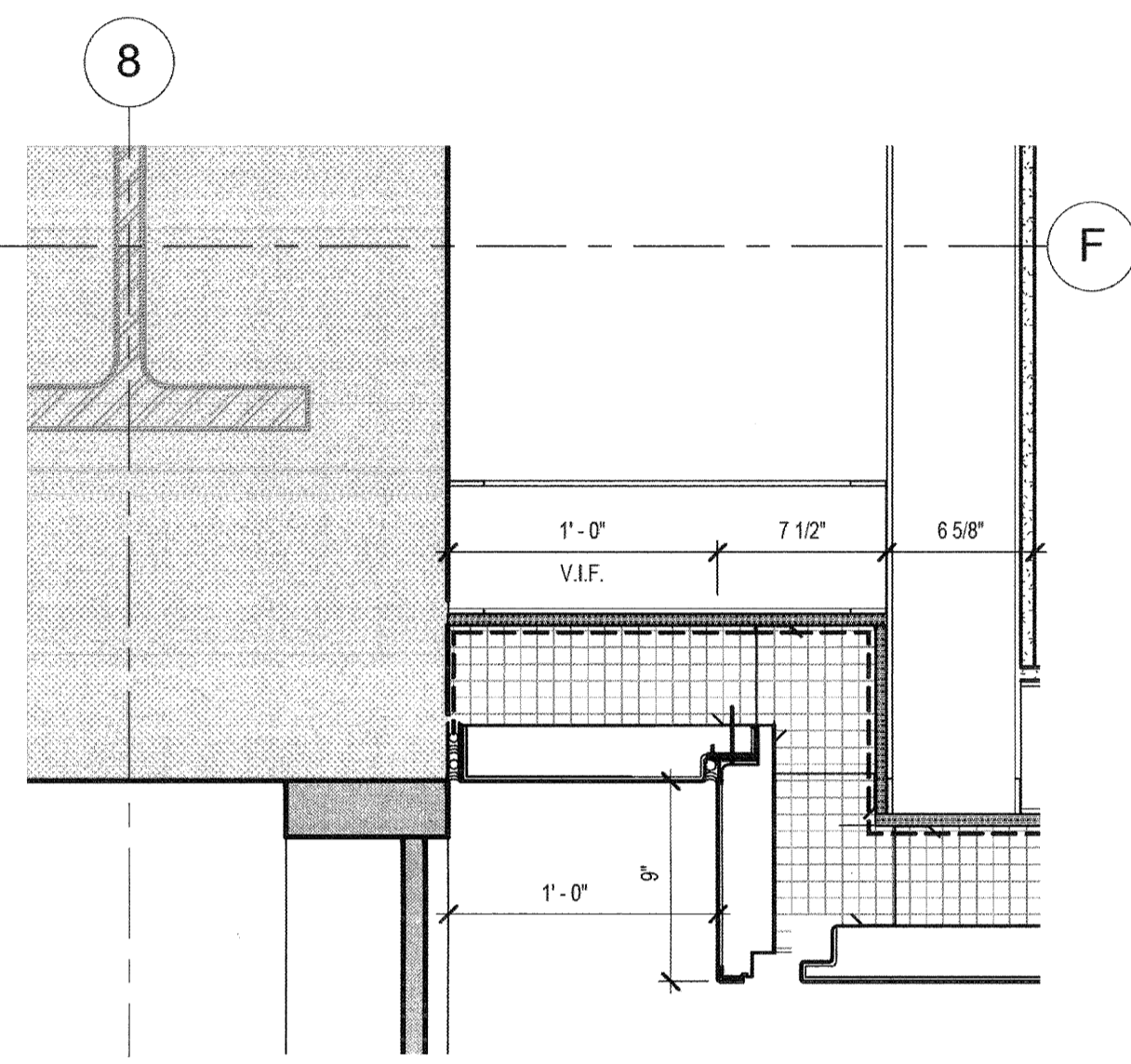

C2 PLAN DETAIL - COLUMN 8F
1 1/2" = 1'-0"

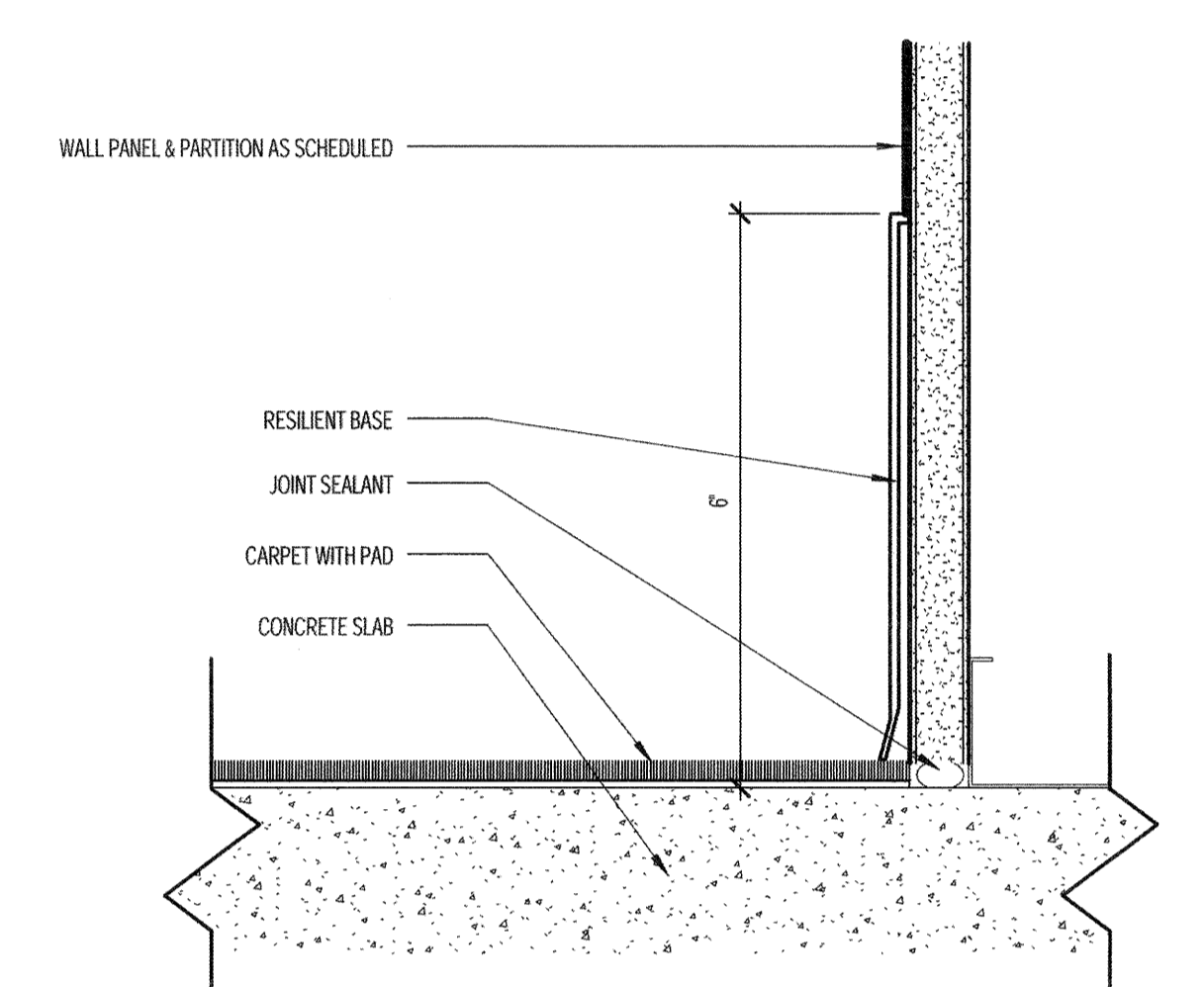

C1 WALL BASE DETAIL RESILIENT BASE @ CARPET
6" = 1'-0"

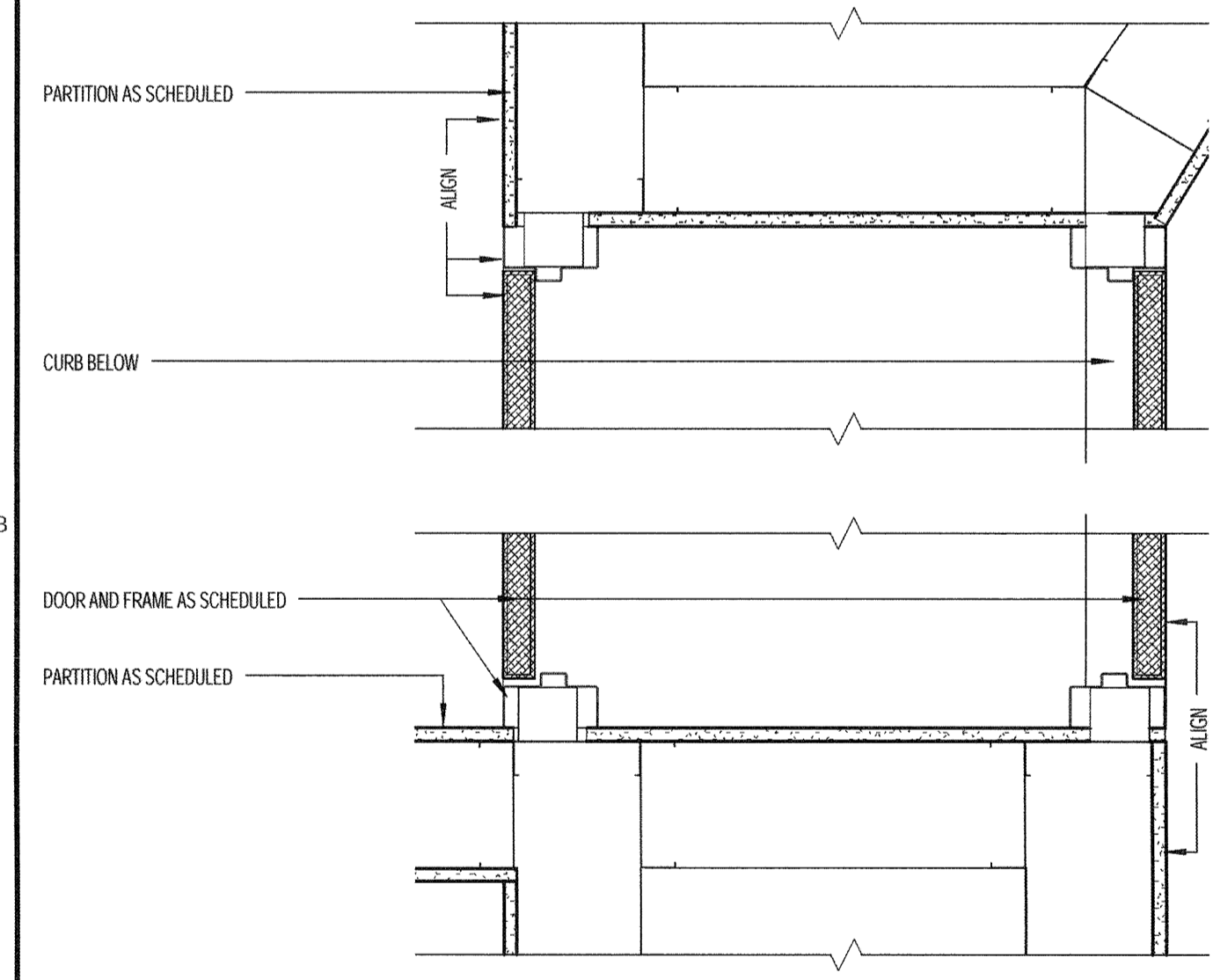

B5 DOORS AND CURB AT OR
1 1/2" = 1'-0"

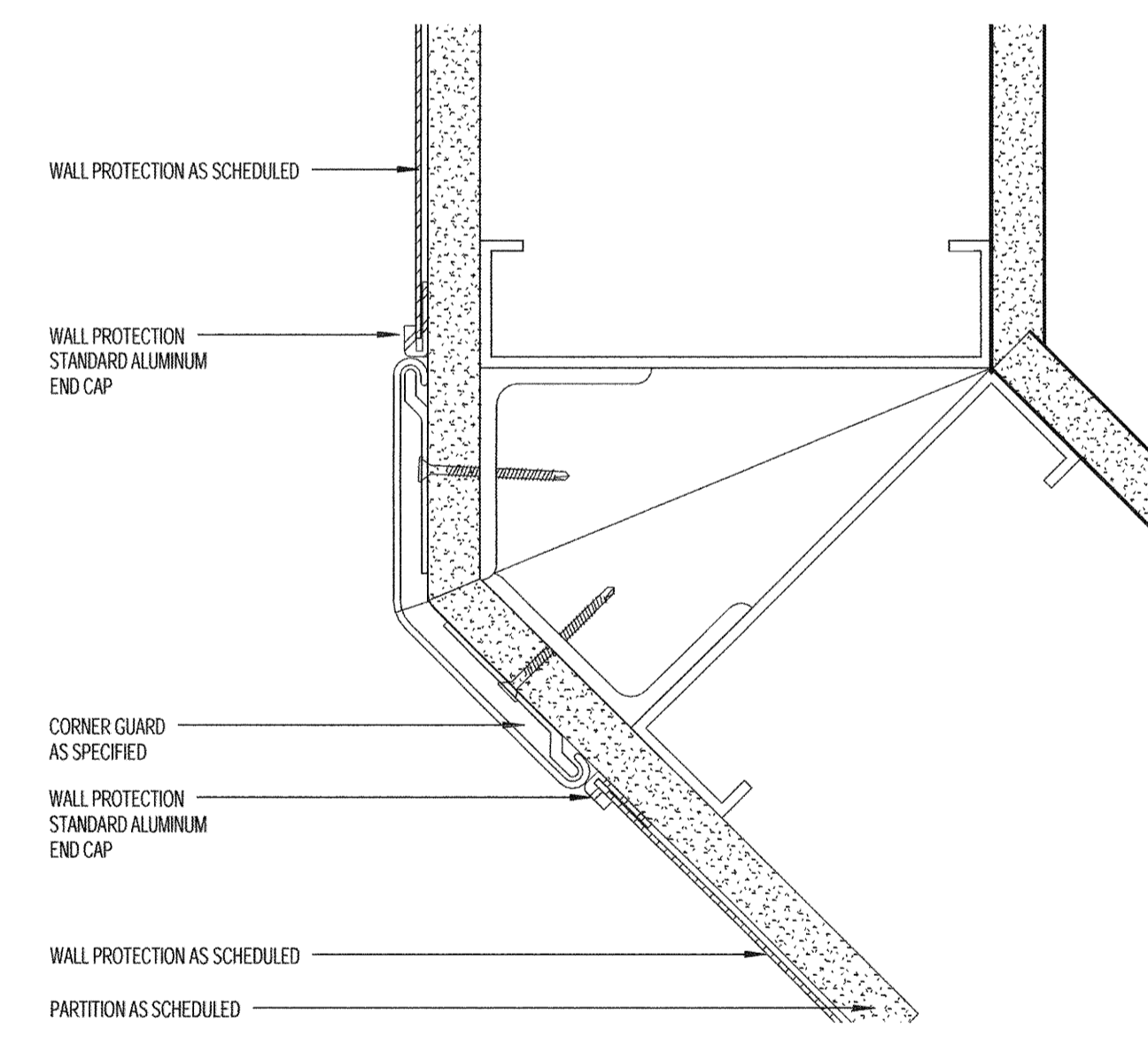

B4 WALL PROTECTION AT OBTUSE CORNER
6" = 1'-0"

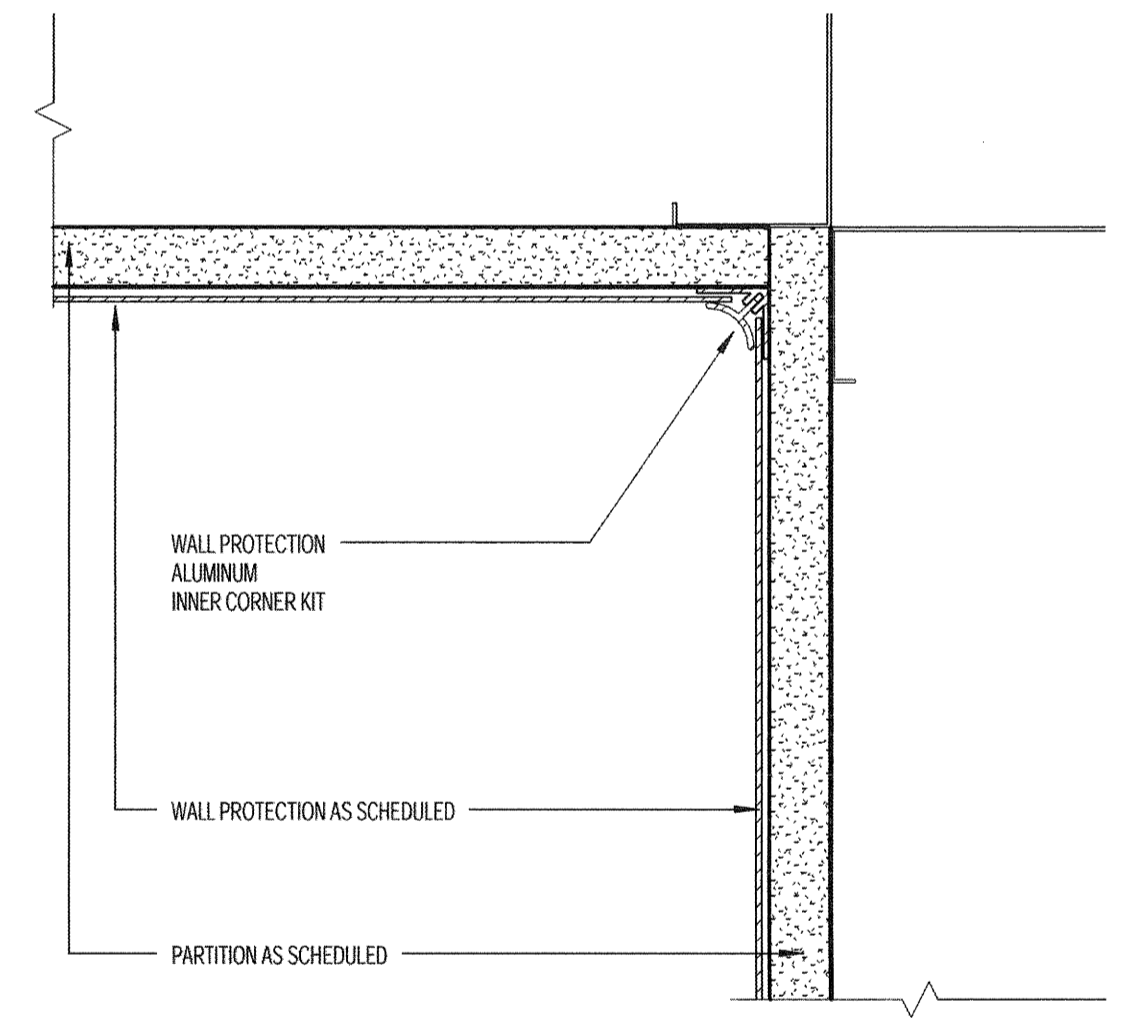

B3 WALL PROTECTION AT INSIDE CORNER
6" = 1'-0"

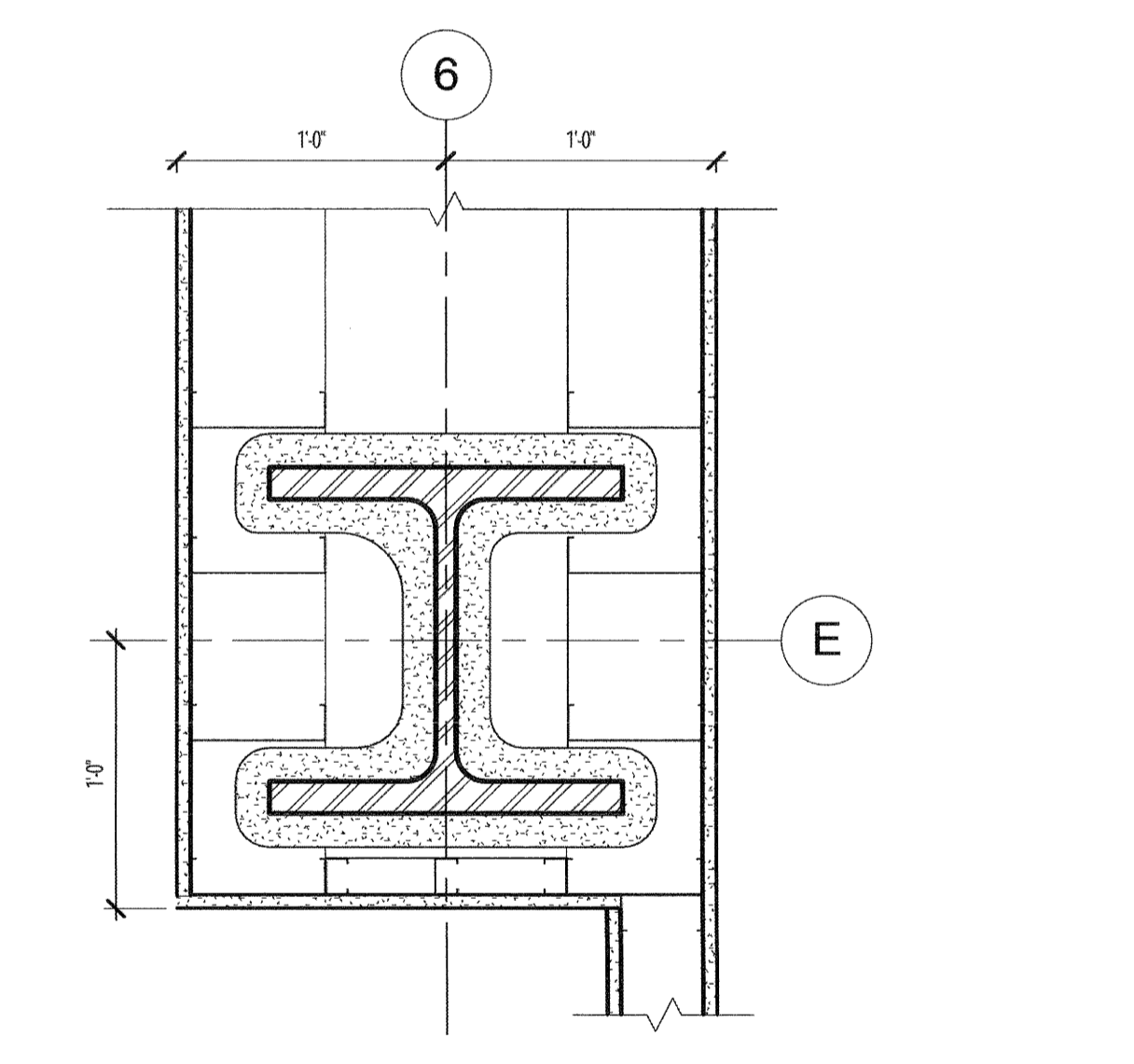

B2 PLAN DETAIL @ COLUMN 6E
1 1/2" = 1'-0"

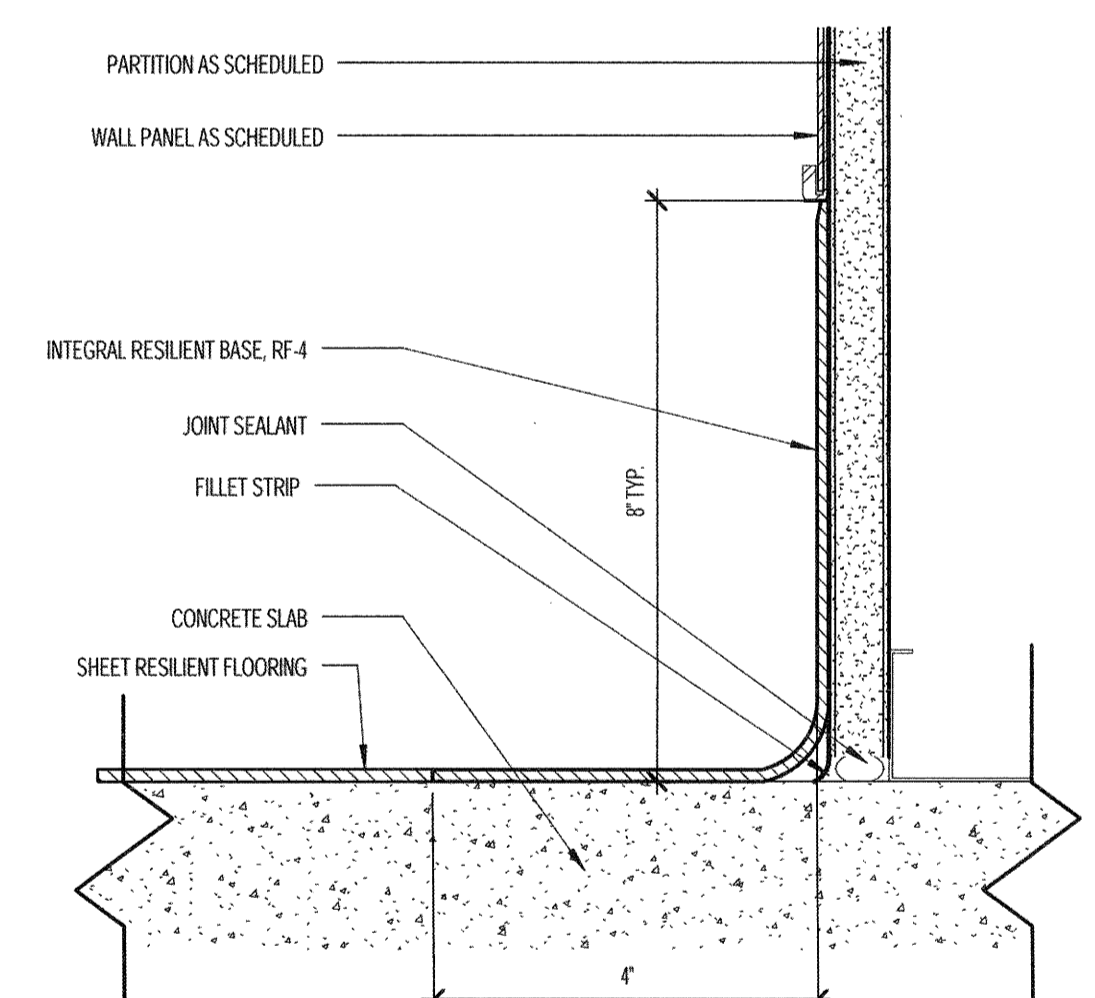

B1 WALL BASE DETAIL RESILIENT BASE @ SHEET RESILIENT FLOORING
6" = 1'-0"

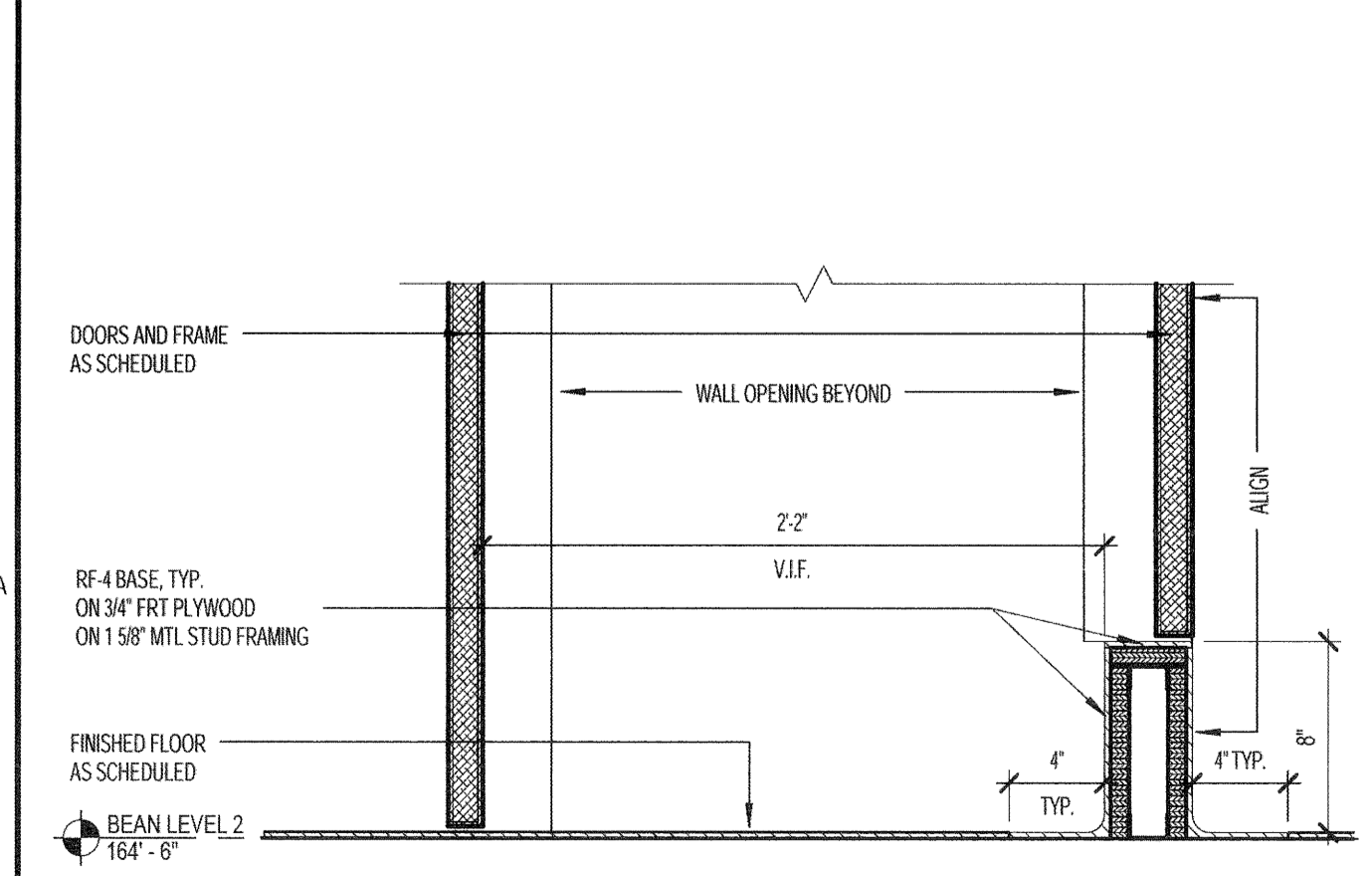

A5 CURB AT O.R.
1 1/2" = 1'-0"

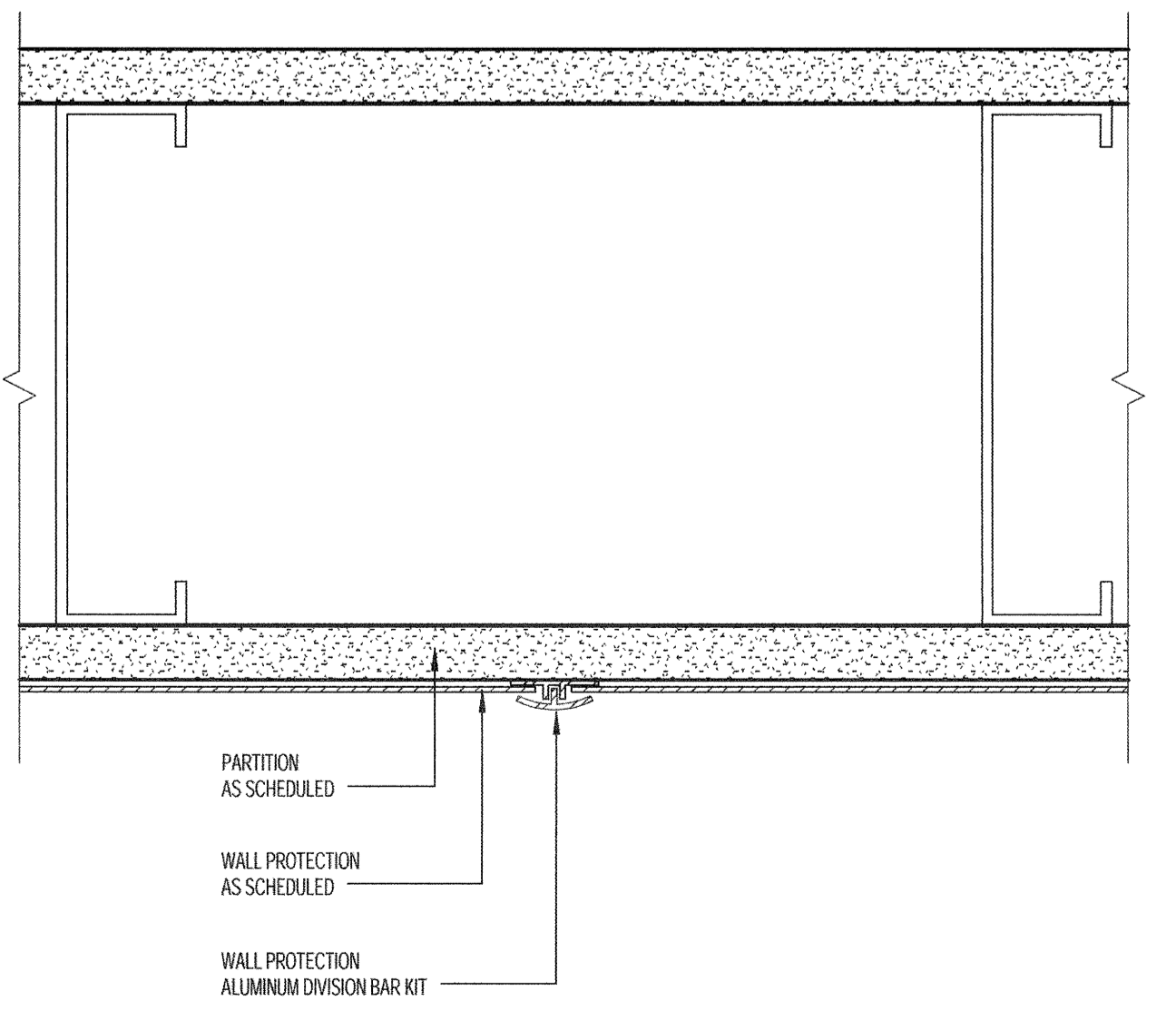

A4 INTERMEDIATE WALL PROTECTION JOINT
6" = 1'-0"

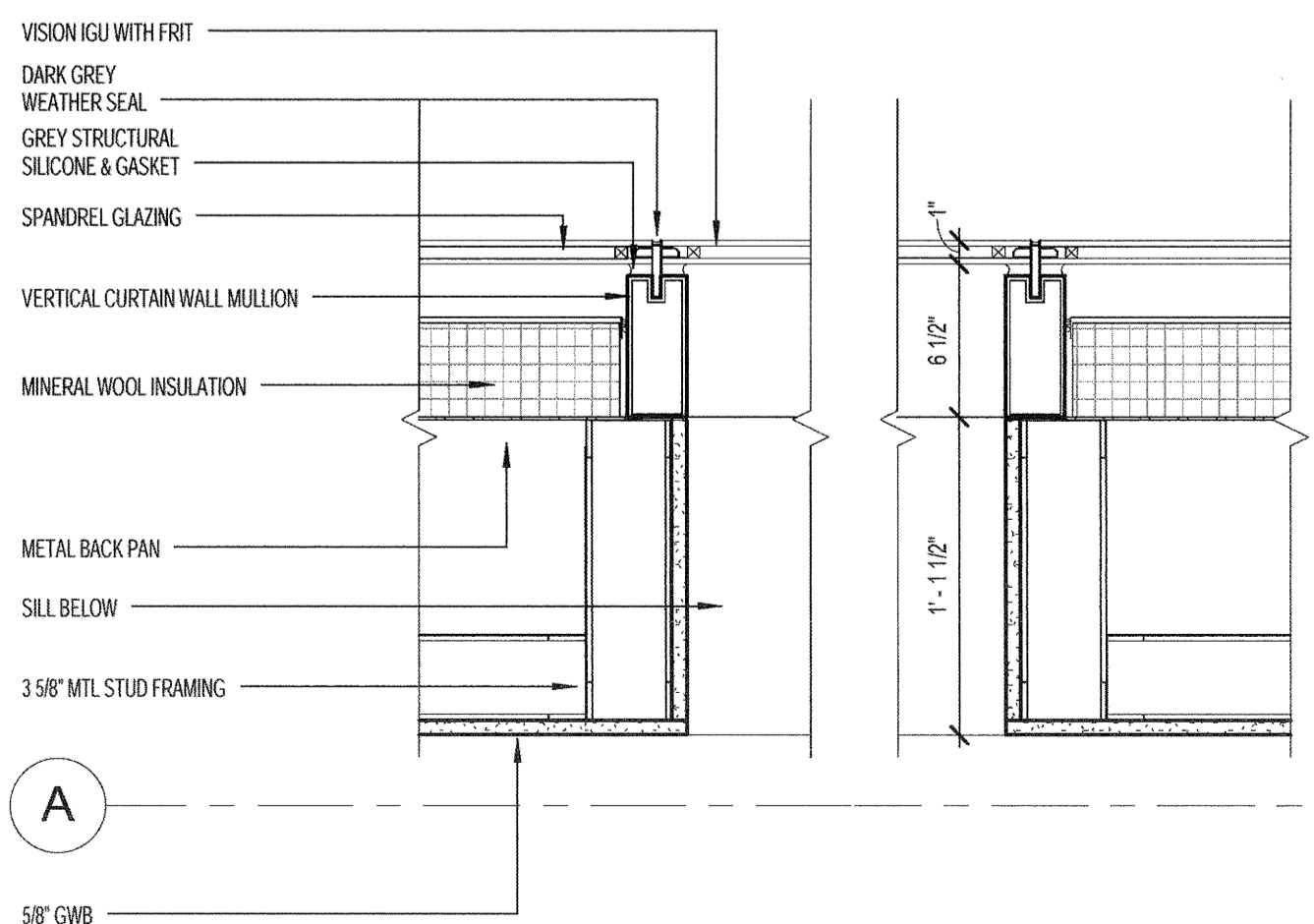

A3 INTERIOR PARTITION AT CURTAIN WALL SPANDREL
1 1/2" = 1'-0"

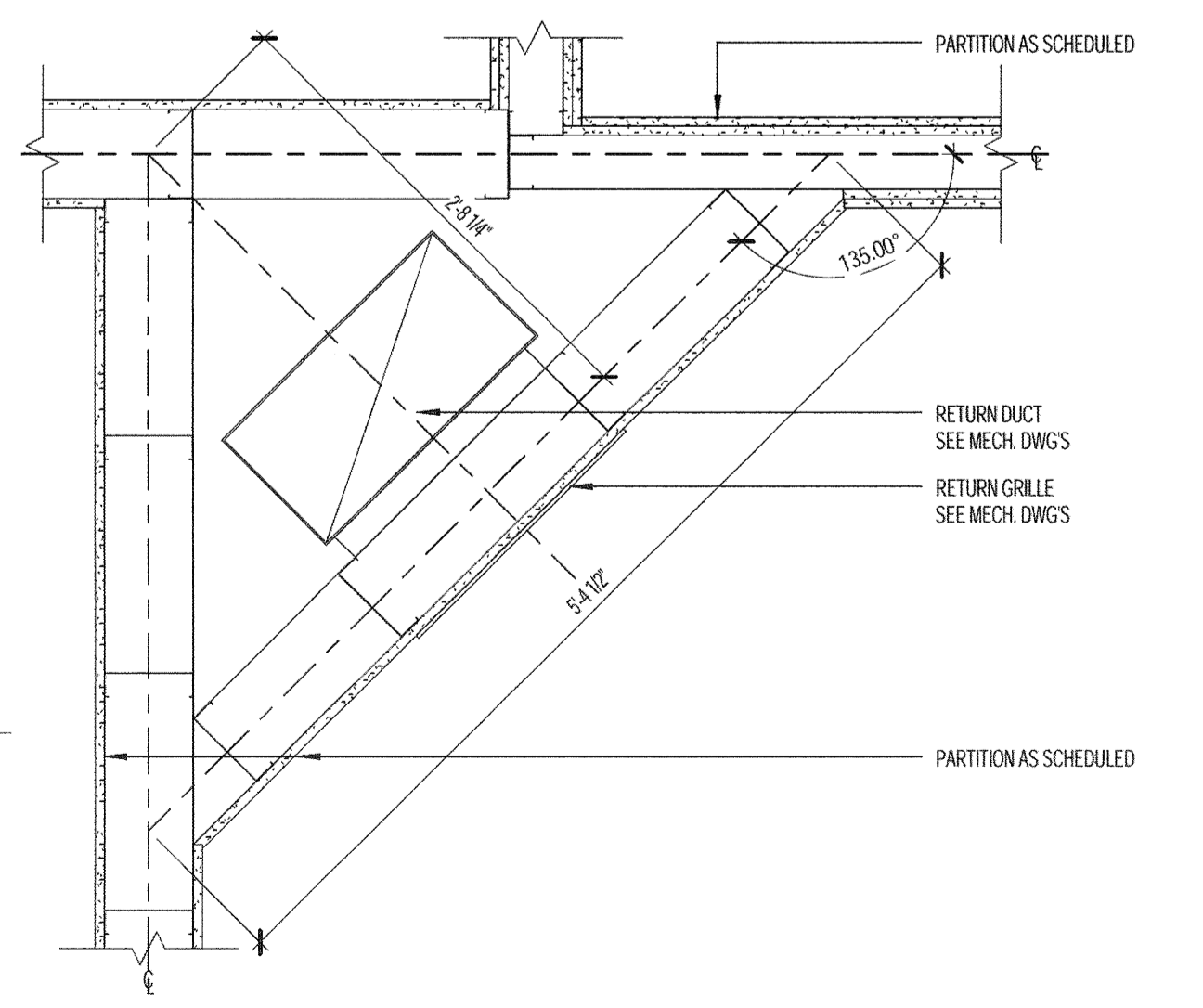

A2 O.R. RETURN
1" = 1'-0"

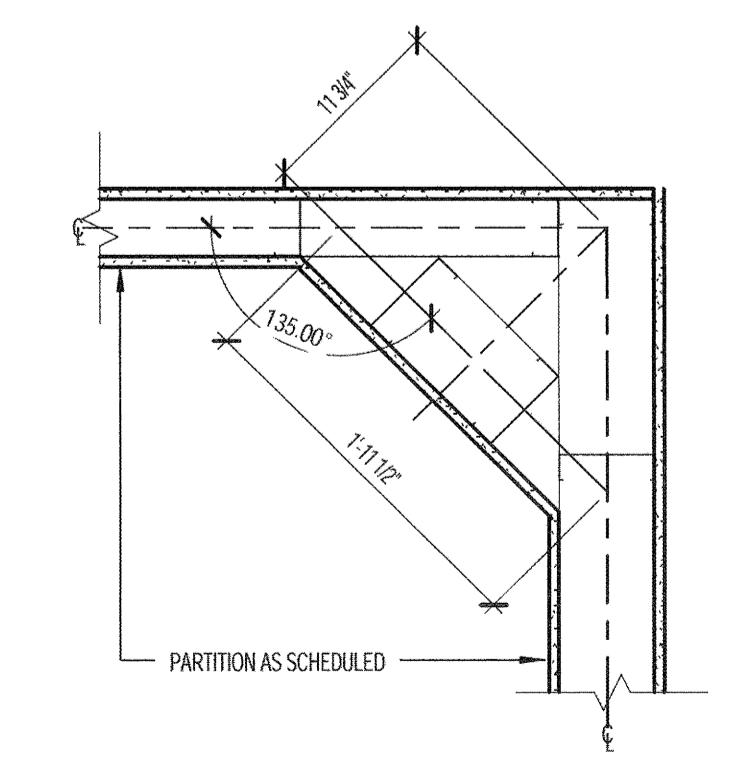

A1 O.R. CORNER FRAMING
1" = 1'-0"

PERKINS + WILL

225 Franklin St., Suite 1100
Boston, MA 02110
617.478.0300
617.478.0321
www.perkinswill.com



Bean 2 Roof Addition
22 Bramhall Street, Portland, Maine 04102

MSP ENGINEER
AKF ENGINEERS
41 Farnsworth Street, 3rd Floor
Boston, MA 02110
617.737.1111
617.737.4311

STRUCTURAL ENGINEER
SIMPSON GUMPERTZ & HEGGER
41 Seyon Street, Building 1, Suite 500
Watkins, MA 02463
781.907.8000
781.907.9009

MEDICAL EQUIPMENT PLANNERS
RTL ASSOCIATES INC.
1717 PACIFIC AVENUE
DALLAS, TX 75201
214.468.7600
214.468.7601

COST ESTIMATOR
DG JONES & PARTNERS
3 Baldwin Green Common, Suite 202
Watkins, MA 01807
781.932.3131
781.932.3199

CONSTRUCTION DOCUMENTS

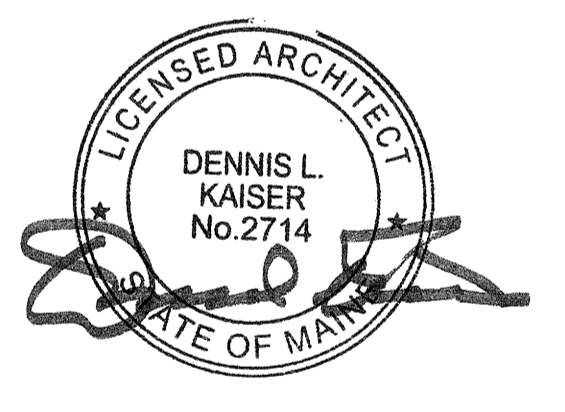

Revisions

NO	ISSUE	DATE
1	ISSUED FOR PERMIT	02/07/2014

Sheet Information
Date: SEPTEMBER 10, 2013
Job #: C140135461 (MMC) 152168.000
Drawn: Author
Checked: Checker
Approved: Approver

INTERIOR PLAN DETAILS

Sheet A10-50