

WINDOW SCHEDULE											
TYPE	OVERALL		TYPE	FINISH	SILL HEIGHT	HEAD HEIGHT	GLAZING	ROOM NAME	ROOM #	SECTOR	ELEVATION REF
MARK	WIDTH	HEIGHT									
1	4'-0"	8'-2"	W2	CLR	0'-0"	8'-2"	KL-3	OFFICE PROGRAM MANAGER	2003	A	BB10-01
2	4'-0"	8'-2"	W2	CLR	0'-0"	8'-2"	KL-3	CONFERENCE ROOM	2004	A	CB10-01
3	10'-0"	9'-4"	W4	CLR	2'-4"	9'-0"	KL-3	FAMILY WAITING	2008	A	EA10-01 & CA10-01
3A	1'-10 3/4"	9'-0"	W4	CLR	0'-0"	9'-0"	KL-3	FAMILY WAITING	2008	A	EA10-01 & CA10-01
4	8'-0"	9'-0"	W2	CLR	0'-0"	9'-0"	KL-3	FAMILY WAITING	2008	A	EA10-01
5	3'-0"	8'-2"	W2	CLR	0'-0"	8'-2"	KL-3	REGISTRATION	2010	A	DA10-01
6	5'-0 1/2"	12'-0"	W4	CLR	0'-0"	12'-0"	KL-3	STAFF LOUNGE	2013	B	BB10-03
7	5'-4 1/2"	12'-0"	W5	CLR	0'-0"	12'-0"	KL-2	STAFF LOUNGE	2013	BC	BB10-05
9	3'-8 1/2"	5'-4"	W4	CLR	2'-10"	8'-2"	KL-2	CONTROL DESK	2010A	BC	BB10-05 & BB10-04
10	3'-0"	5'-4"	W4	CLR	2'-10"	8'-2"	KL-2	CONTROL DESK	2010A	BC	BB10-04
11	10'-3"	5'-4"	W1-SLIDER	CLR	2'-10"	8'-2"	KL-2	CONTROL DESK	2010A	BC	BB10-04
12	2'-0"	4'-8"	W1	CLR	2'-0"	8'-2"	KL-2	WORK ROOM	2011	C	BB10-06
13	1'-11"	12'-0"	W2	CLR	0'-0"	12'-0"	KL-2	CLEAN SUPPLY	2013	C	EA10-06
14	4'-0"	8'-2"	W2	CLR	0'-0"	8'-2"	KL-2	RADIOLOGY WORKROOM	2017	C	DU10-05
15	10'-0"	1'-10"	W1	CLR	8'-2"	10'-0"	KL-2	NEUROSPINE OR	2010	C	DA10-05
16	8'-0"	2'-10"	EXTERIOR	WHITE	6'-10 3/4"	9'-11 1/2"	-	PACUPASSAGE	DC-PAC104	B	BB11-00
17	8'-0"	2'-8 3/4"	EXTERIOR	WHITE	6'-10 3/4"	9'-11 1/2"	-	PACUPASSAGE	DC-PAC108	B	BB11-00
18	8'-0"	2'-8 3/4"	EXTERIOR	WHITE	6'-10 3/4"	9'-11 1/2"	-	PACUPASSAGE	DC-PAC107	B	BB11-00

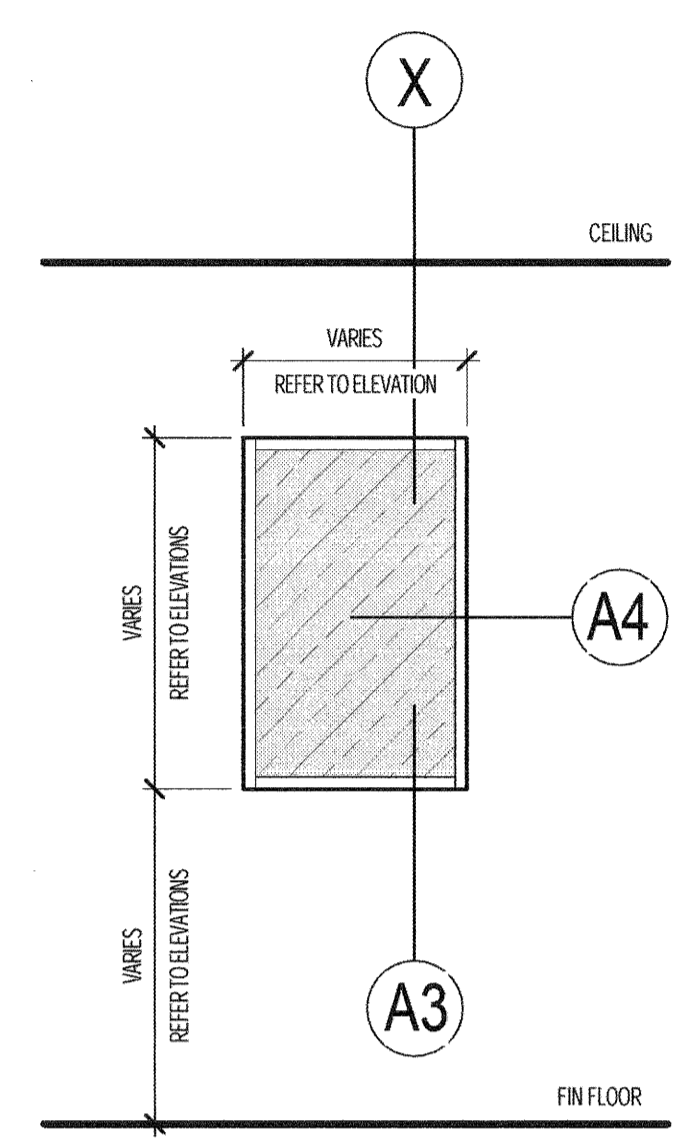

**W1 - FIXED SYSTEM**

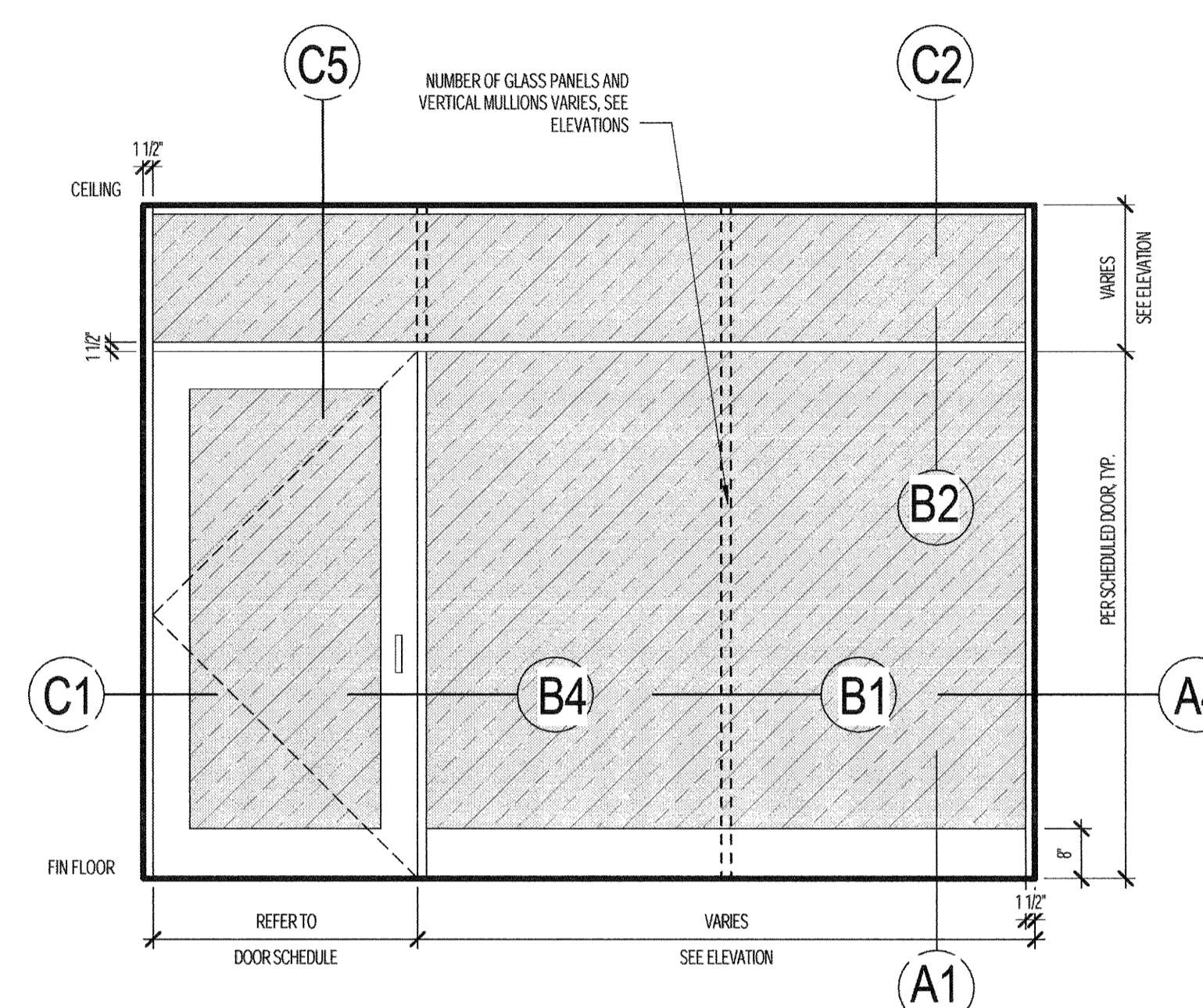

**W2 - STOREFRONT SYSTEM**

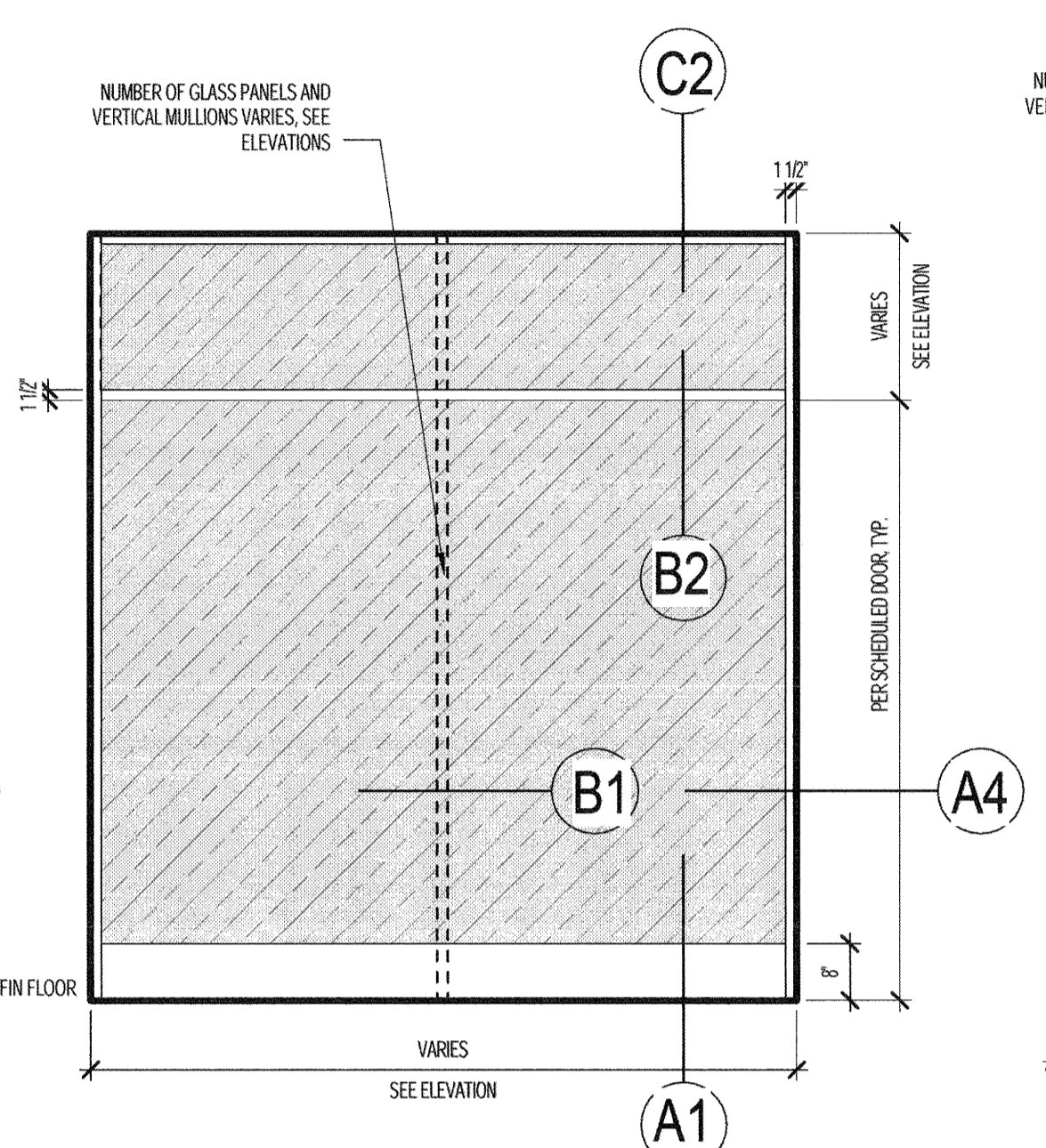

**W3 - STOREFRONT SYSTEM**

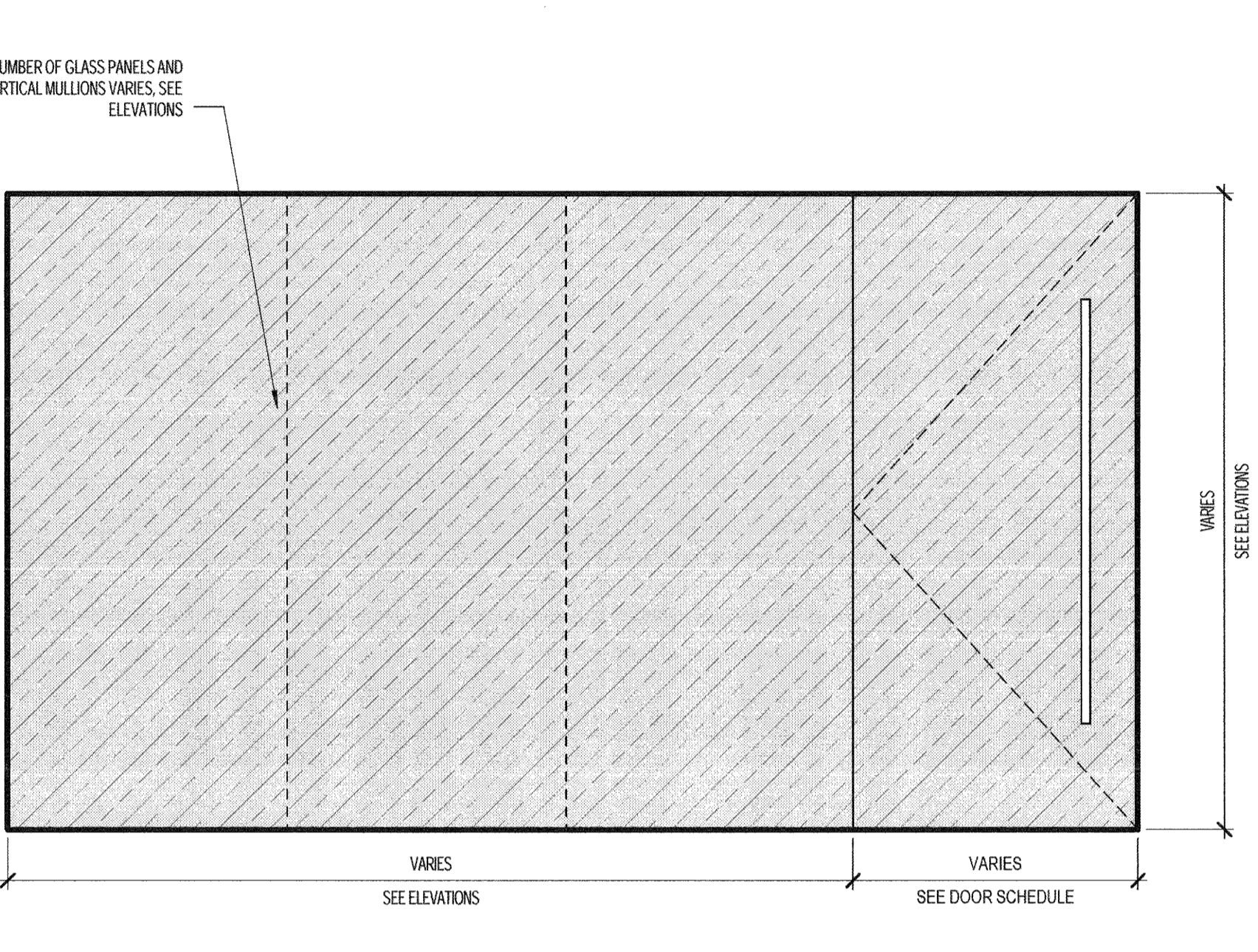

**W4 - BUTT GLAZED SYSTEM**

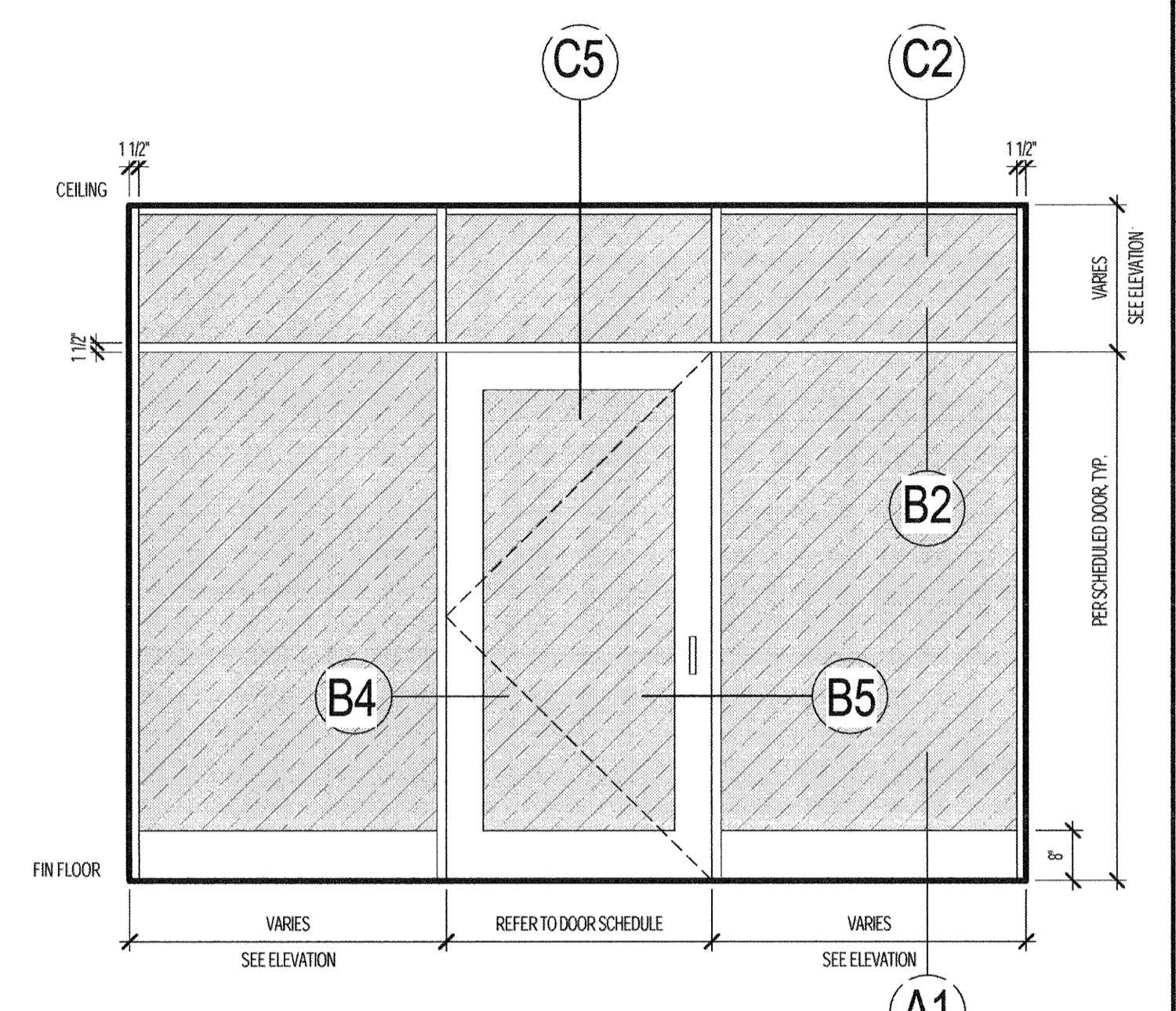

**W5 - STOREFRONT SYSTEM**

**D5 WINDOW TYPES**  
1/2" = 1'-0"

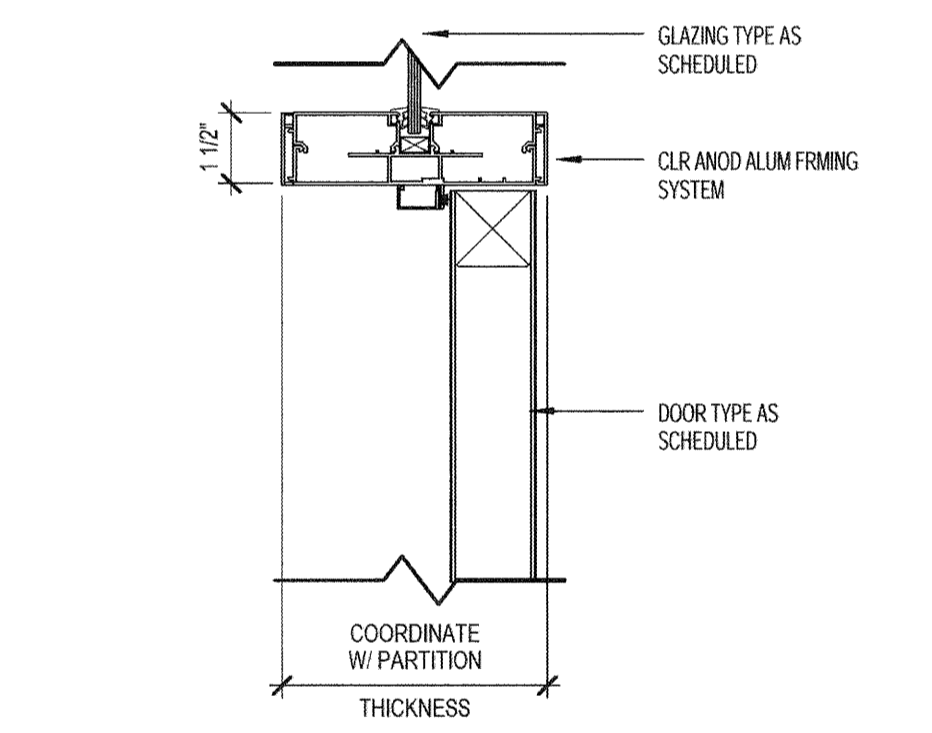

**C4 ALUM TRANSOM @ DOOR**  
3" = 1'-0"

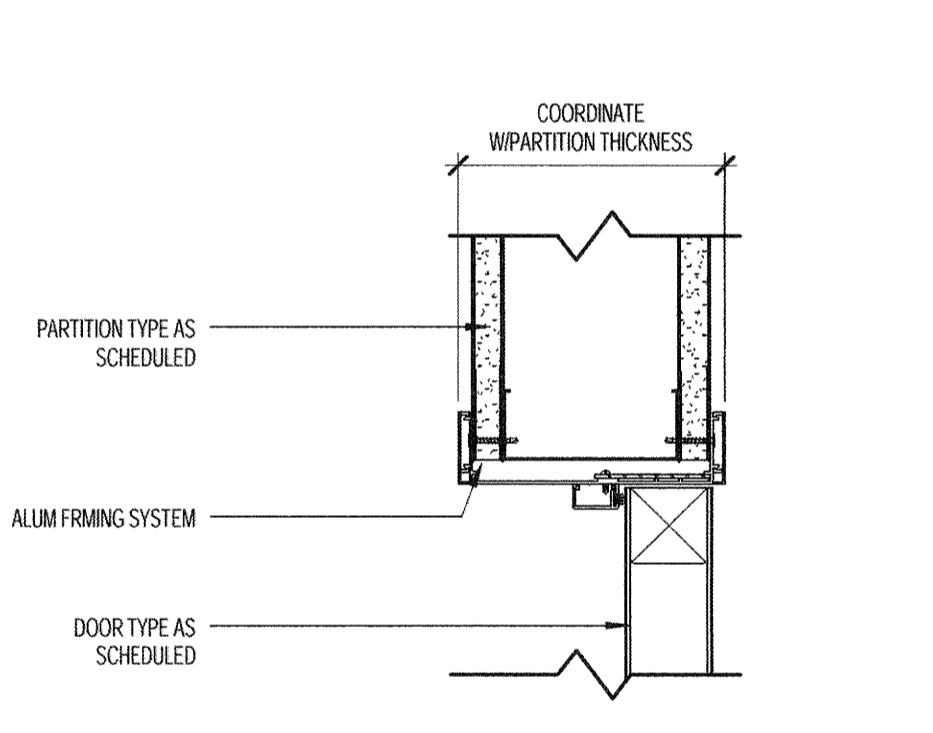

**C3 ALUM DOOR HEAD @ GWB**  
3" = 1'-0"

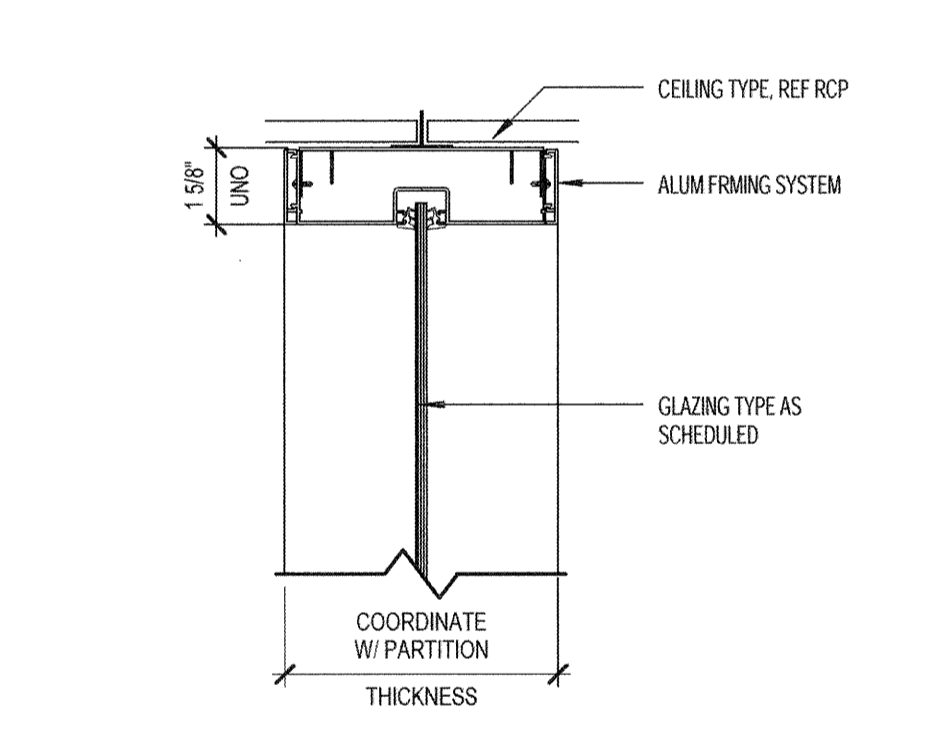

**C2 ALUM/GLASS HEAD**  
3" = 1'-0"

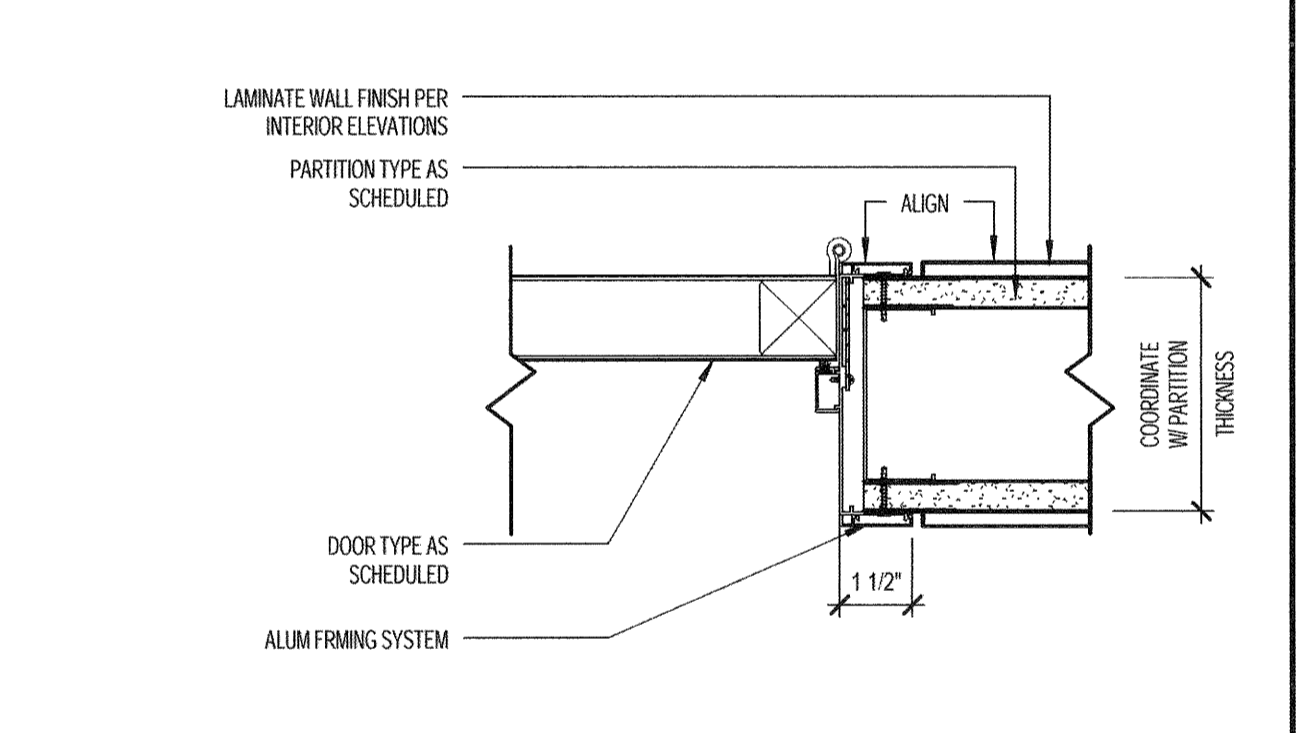

**C1 ALUM DOOR JAMB @ GWB**  
3" = 1'-0"

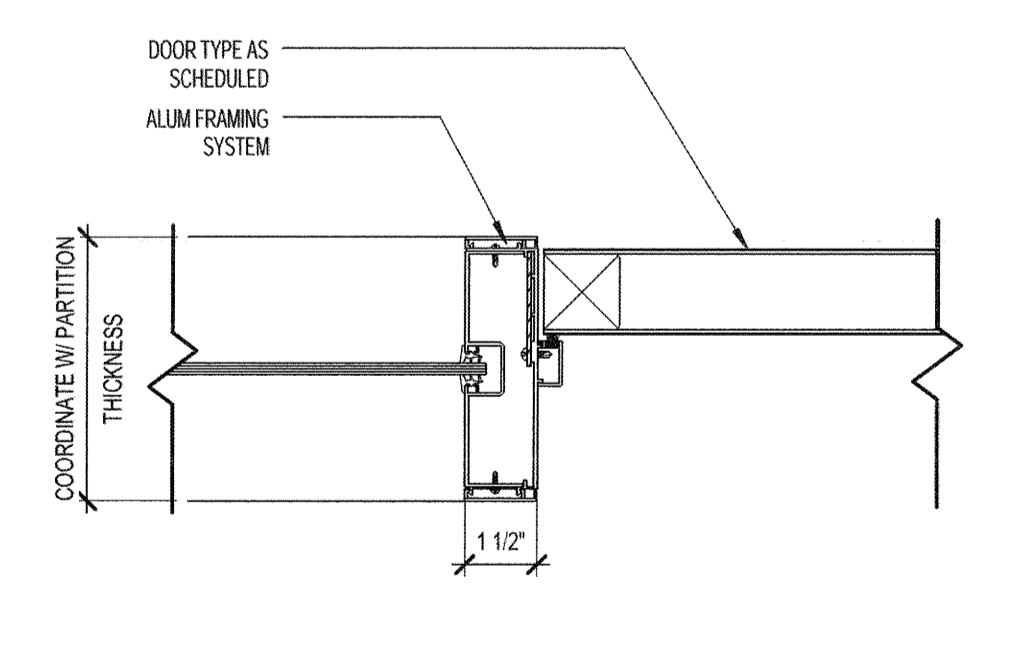

**B5 ALUM DOOR LATCH AT SIDELITE**  
3" = 1'-0"

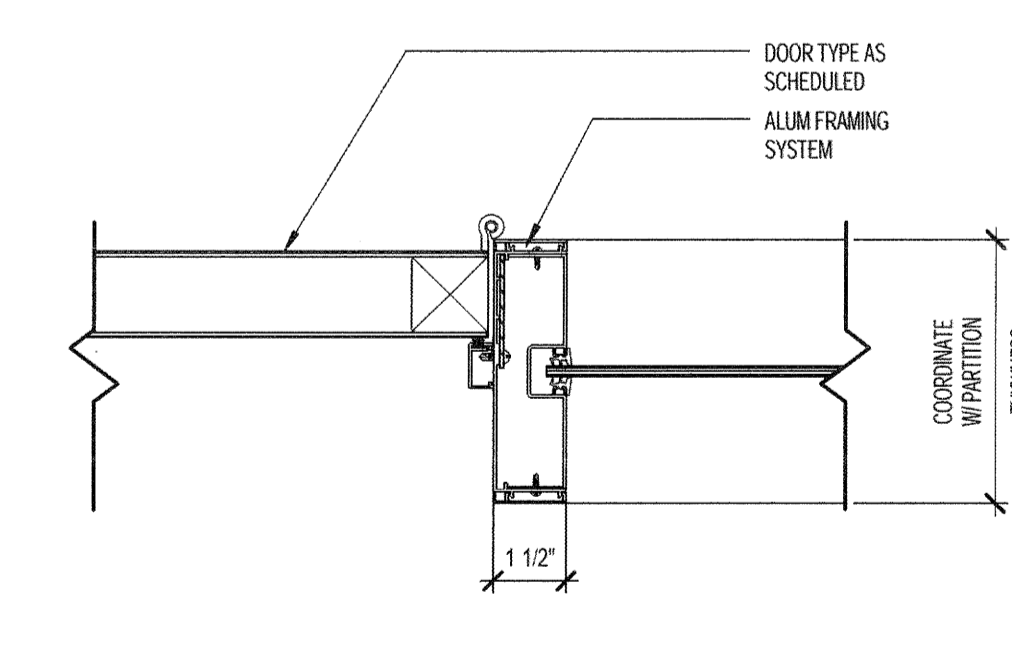

**B4 ALUM DOOR JAMB AT SIDELITE**  
3" = 1'-0"

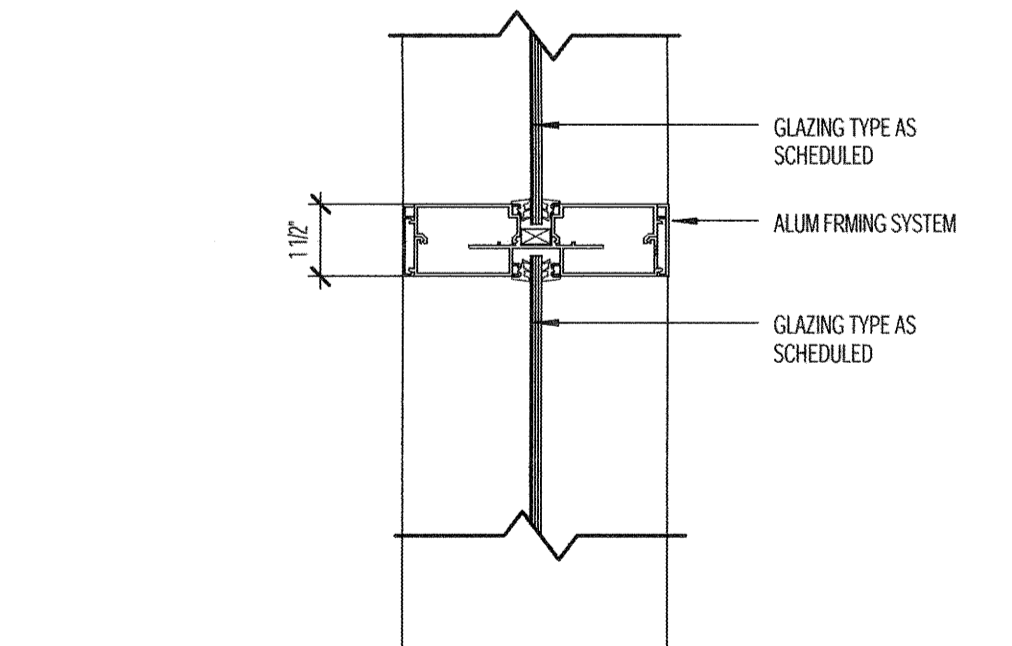

**B3 ALUM HORIZ MULLION**  
3" = 1'-0"

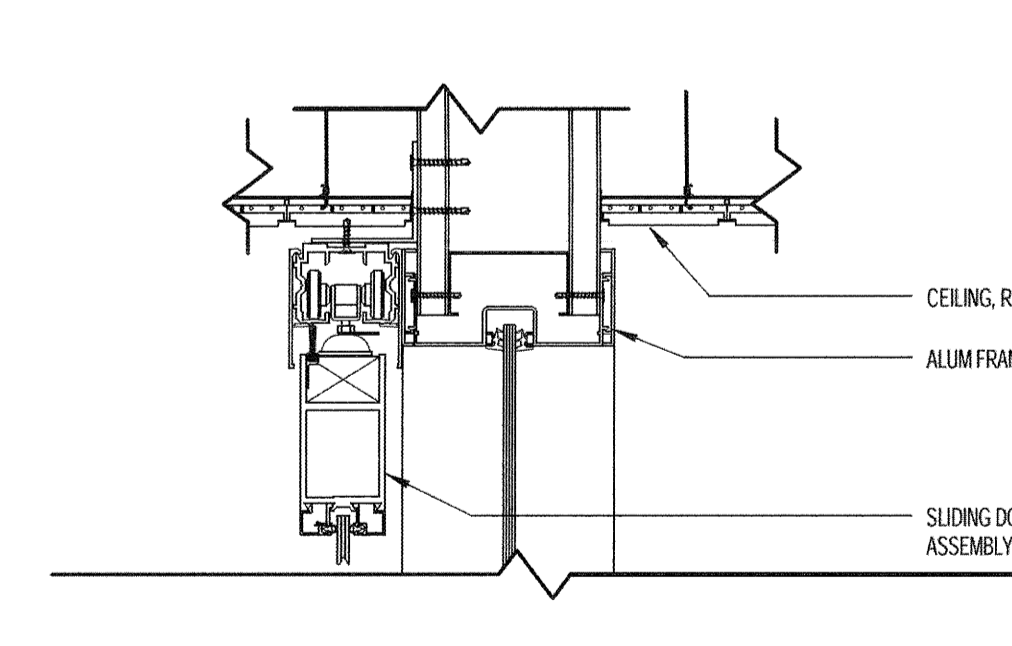

**B2 ALUM SLIDING DOOR HEAD**  
3" = 1'-0"

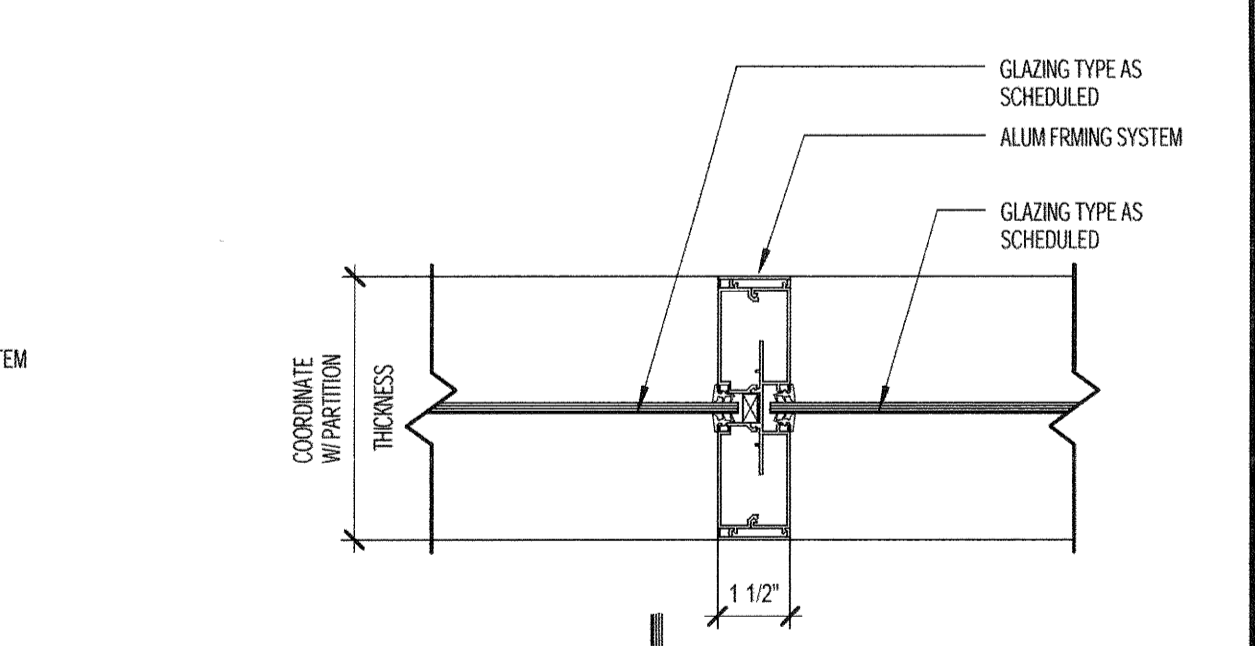

**B1 ALUM VERT MULLION**  
3" = 1'-0"

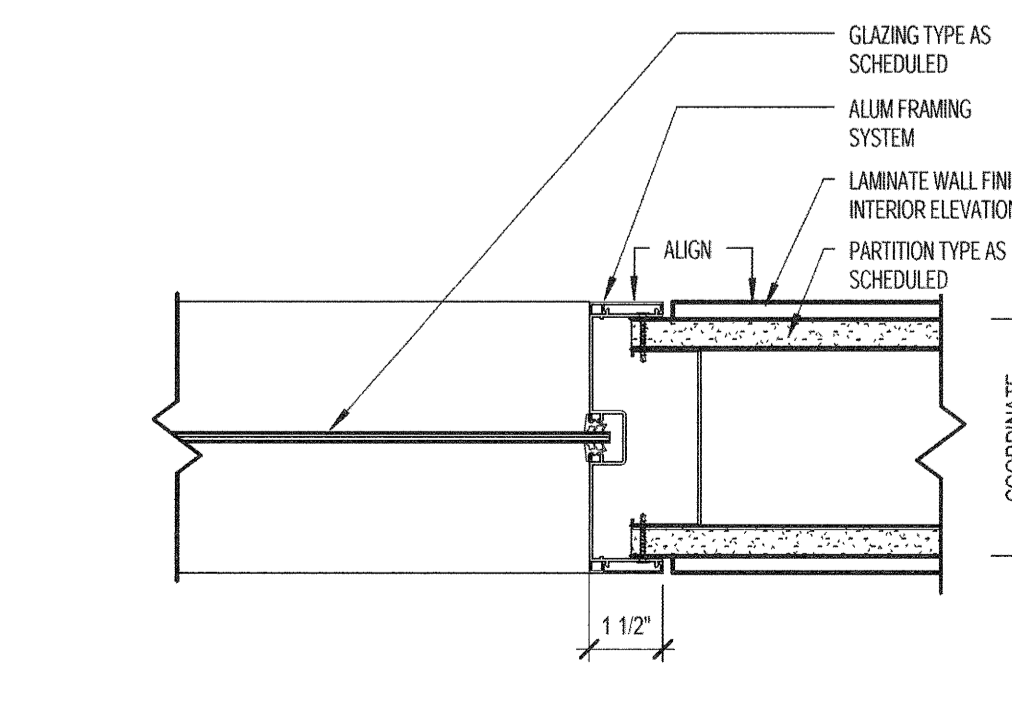

**A5 ALUM/GLASS JAMB AT GWB**  
3" = 1'-0"

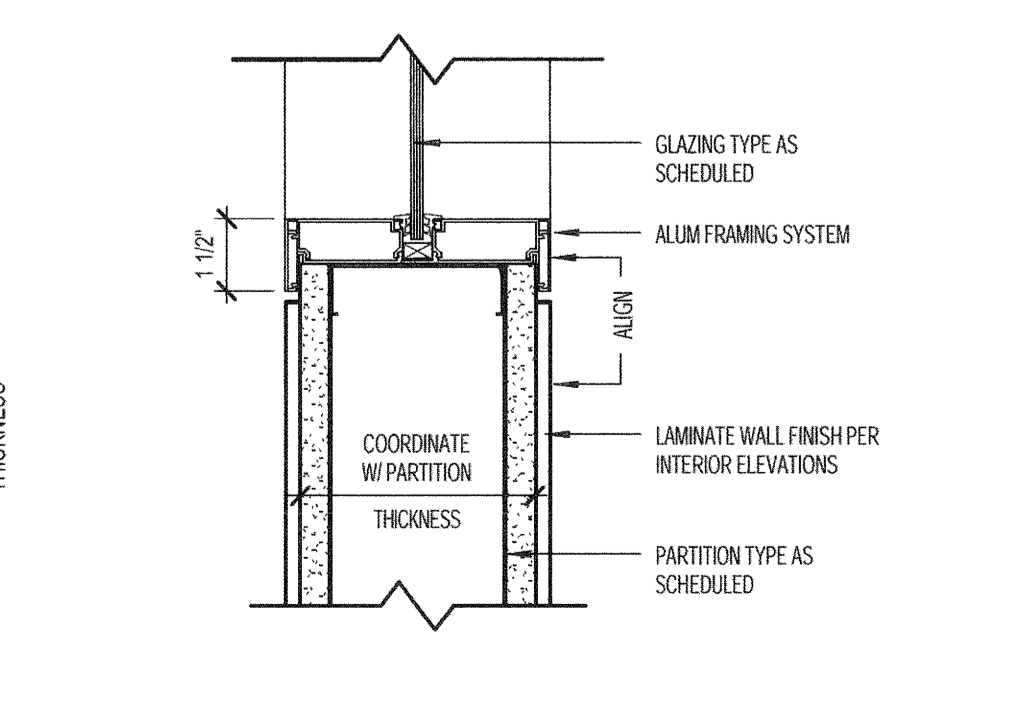

**A4 ALUM/GLASS SILL AT GWB**  
3" = 1'-0"

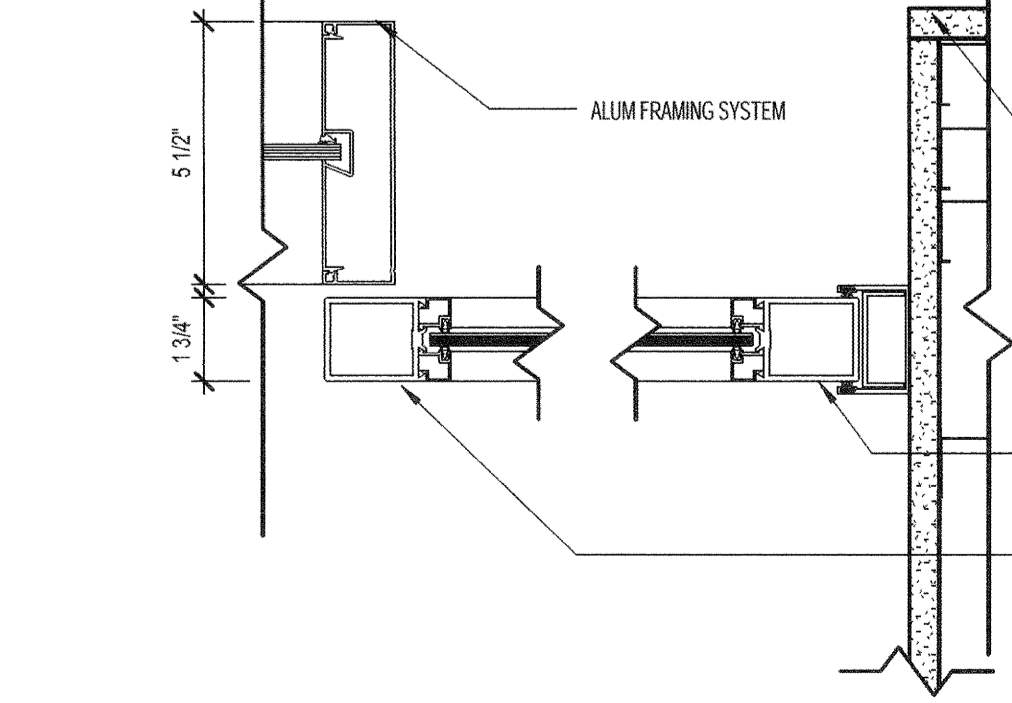

**A3 ALUM SLIDING DOOR JAMB**  
3" = 1'-0"

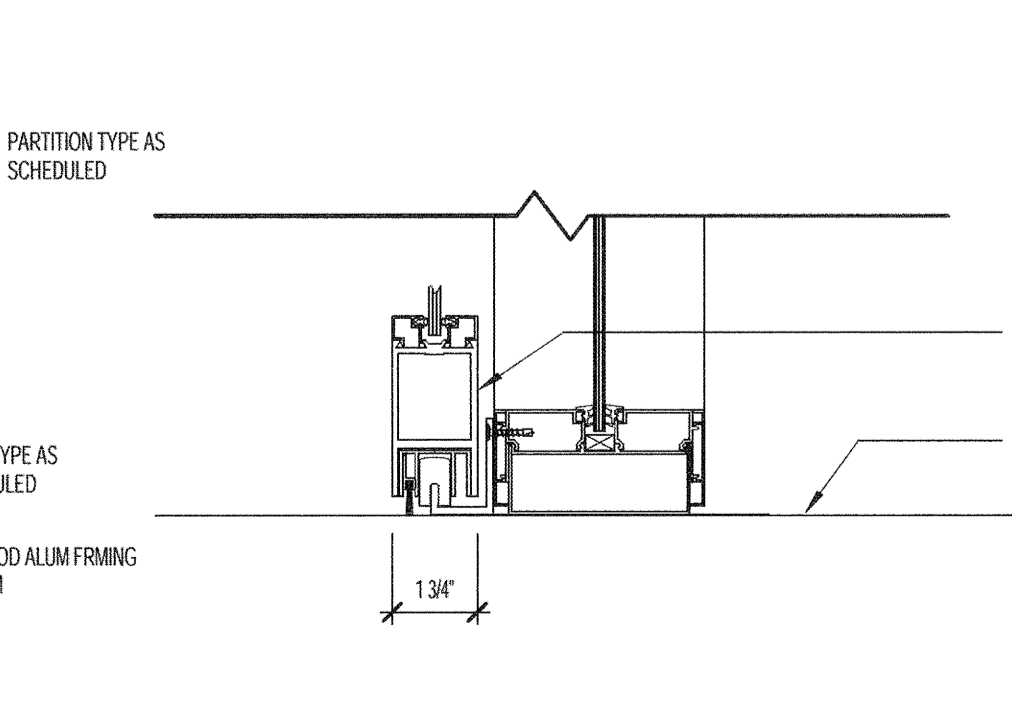

**A2 ALUM SLIDING DOOR SILL**  
3" = 1'-0"

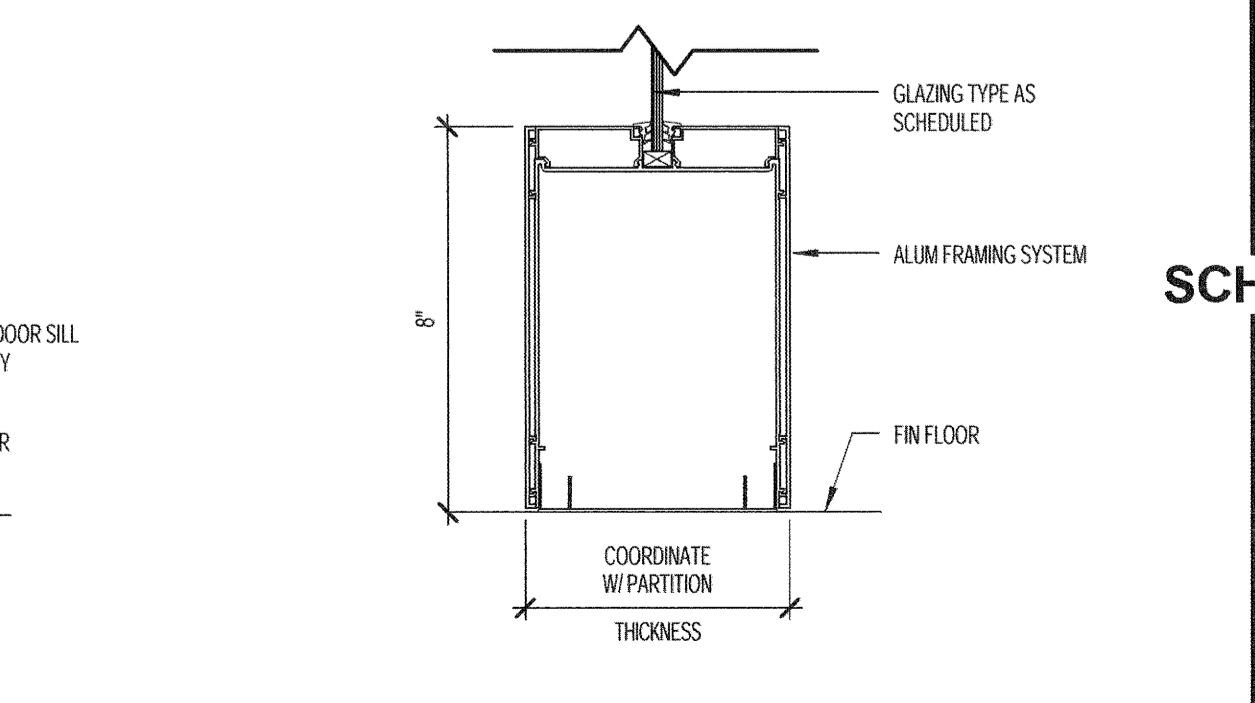

**A1 ALUM/GLASS SILL AT FLOOR**  
3" = 1'-0"

**CONSTRUCTION DOCUMENTS**

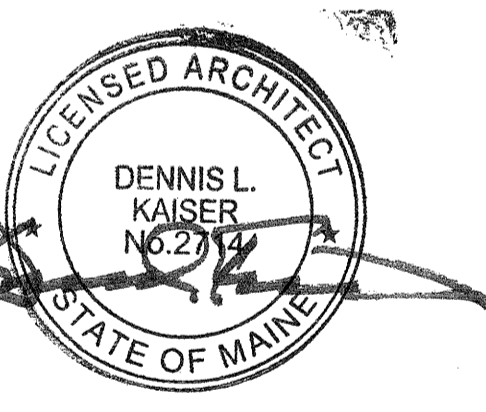

Revisions

Issued for Permit	02/07/2014
NO.	ISSUE DATE
<b>Sheet Information</b>	
Date	SEPTEMBER 10, 2013
Job #	C140135461 (MMC)'152168.000
Drawn	Author
Checked	Checker
Approved	Approver
Title	

**WINDOW SCHEDULE/TYPES/DETAILS**

Sheet  
**A00-60**