

ELECTRICAL NOTES:

1. ELECTRICAL DESIGN IS BY DESIGN-BUILD SUBCONTRACTOR. LIGHT FIXTURE, NURSE CALL, MED GAS ALARM PANEL AND PAR-EX LOCATIONS ARE SHOWN TO COMMUNICATE DESIGN INTENT.
2. PROVIDE OCCUPANCY SENSOR AT CLEAN SUPPLY ROOM 2804.
3. PROVIDE 2 CONVENIENCE POWER RECEPTACLES AT ROOM 2804.
4. PROVIDE ROUGH-IN FOR VOICE/DATA TO INCLUDE: 1 GANG BACKBOX LOCATED AT 18" AFF WITH 3/4" CONDUIT STUBBED ABOVE THE CEILING. A RUBBER GASKET AND PULL STRING ARE NEEDED AT ALL BACKBOXES.
5. PROVIDE BACK BOXES FOR NURSE CALL DEVICES AT 48" AFF U.N.O.
6. EXISTING SPEAKERS TO REMAIN. PROVIDE SPEAKER IN ROOM 2804.
7. PROVIDE SMOKE DETECTORS AS REQUIRED BY CODE TO RELEASE DOOR HOLDER AT DOOR 2804 AND AS REQUIRED BY CODE AT EQUIPMENT 2823.
8. POWER AND DATA ARE REQUIRED AT ALL NEW COMPUTER, COPIER, PAR-EX SCANNER AND MEDICATION DISPENSER LOCATIONS.
9. PROVIDE DUPLEX POWER RECEPTACLE AT REFRIGERATOR LOCATION IN 2806.
10. PROVIDE UNDER-CABINET LIGHTING WHERE NOTED.

MECHANICAL / PLUMBING / FIRE SUPPRESSION NOTES:

1. MECHANICAL, PLUMBING AND FIRE PROTECTION DESIGN IS BY DESIGN-BUILD SUBCONTRACTORS.
2. RELOCATE / BALANCE HVAC SYSTEM COMPONENTS AS REQUIRED FOR REVISED ROOM FUNCTIONS AND CONFIGURATIONS.
3. CAP PIPING IN WALL WHERE EXISTING PLUMBING FIXTURE IS REMOVED.
4. MODIFY EXISTING SPRINKLER SYSTEM AS REQUIRED TO PROVIDE FIRE SUPPRESSION PER NFPA 13.

K1 REFLECTED CEILING PLAN - 2826

K6 FURNITURE PLAN - 2826

K11 ELECTRICAL / MECHANICAL / SPRINKLER NOTES

1/4" = 1'-0"

1/4" = 1'-0"

N.T.S.

ROOM FINISH SCHEDULE

NO.	ROOM NAME	FLOOR	BASE	WALL				CEILING		REMARKS
				NORTH	EAST	SOUTH	WEST	MAT'L	HEIGHT	
2804	CLEAN SUPPLY	EXIST	EXIST	PTD-1	PTD-1	PTD-1	PTD-1	EXIST	EXIST	1
2806	MEDICATIONS	EXIST	EXIST	PTD-1	PTD-1	PTD-1	PTD-1	EXIST	EXIST	
2810	ALCOVE	EXIST	EXIST	PTD-1	PTD-1	PTD-1	PTD-1	EXIST	EXIST	
2812	STAFF STATION	EXIST	EXIST	PTD-1	*	*	PTD-1	EXIST	EXIST	
2823	EQUIPMENT	EXIST	EXIST	PTD-1	PTD-1	PTD-1	PTD-1	EXIST	EXIST	
2826	WORKROOM	RUBBER	RUBBER	PTD-1	PTD-1	PTD-1	PTD-1	EXIST/ACT	EXIST	1, 2, 3

FINISH SCHEDULE REMARKS KEY:

1. PAINT CORRIDOR WALLS AFFECTED BY NEW WORK.
2. SEE REFLECTED CEILING PLAN FOR LOCATIONS OF NEW CEILING TILE AND GRID. MATCH ADJACENT EXISTING CEILING HEIGHT AND MATERIALS.
3. SEE FLOOR PLAN FOR LOCATION OF NEW FLOORING.

FINISH SPECIFICATIONS:

RUBBER FLOORING: MATCH EXISTING

BASE: 4" RUBBER COVE BASE, TRADITIONAL PROFILE. MATCH EXISTING.

PAINT: PAINT NEW AND EXISTING WALLS AND TRIM AS INDICATED. PROVIDE ONE FINISH COAT AT EXISTING SURFACES. PROVIDE PRIMER AND 2 COATS AT NEW SURFACES. COLORS TO BE SELECTED. ALLOW FOR 2 COLOR SELECTIONS. PAINT PRODUCTS ARE AS FOLLOWS:

ACOUSTICAL CEILING: MATCH EXISTING TILE. 9/16" GRID TO MATCH EXISTING.

DOOR SCHEDULE

DOOR NO.	DOOR		GLAZE	FRAME		HWS	FIRE RTG. (MIN.)
	SIZE	MAT'L		MAT'L	ELEV		
2804	3'-0" X 7'-0"	WOOD	NG	TEMP.	HM	1	45
2806	EXIST	EXIST	EXIST	*	EXIST	*	*
2806A	EXIST	EXIST	EXIST	*	EXIST	*	*
2826	EXIST	EXIST	EXIST	*	EXIST	*	2

DOOR HARDWARE:

1. HINGES, LOCKSET, ELECTRIC STRIKE, ELECTROMAGNETIC DOOR HOLDER, 180° DOOR CLOSER, WALL STOP. ELECTRIC STRIKE TO BE OPERATED BY CARD READER. LOCKSET AND CARD READER TO BE RELOCATED FROM EXISTING DOOR 2826.
2. EXISTING HINGES AND CLOSER TO REMAIN. PROVIDE NEW LOCKSET (CLASSROOM FUNCTION).

E1 DOOR AND FINISH SCHEDULES

N.T.S.

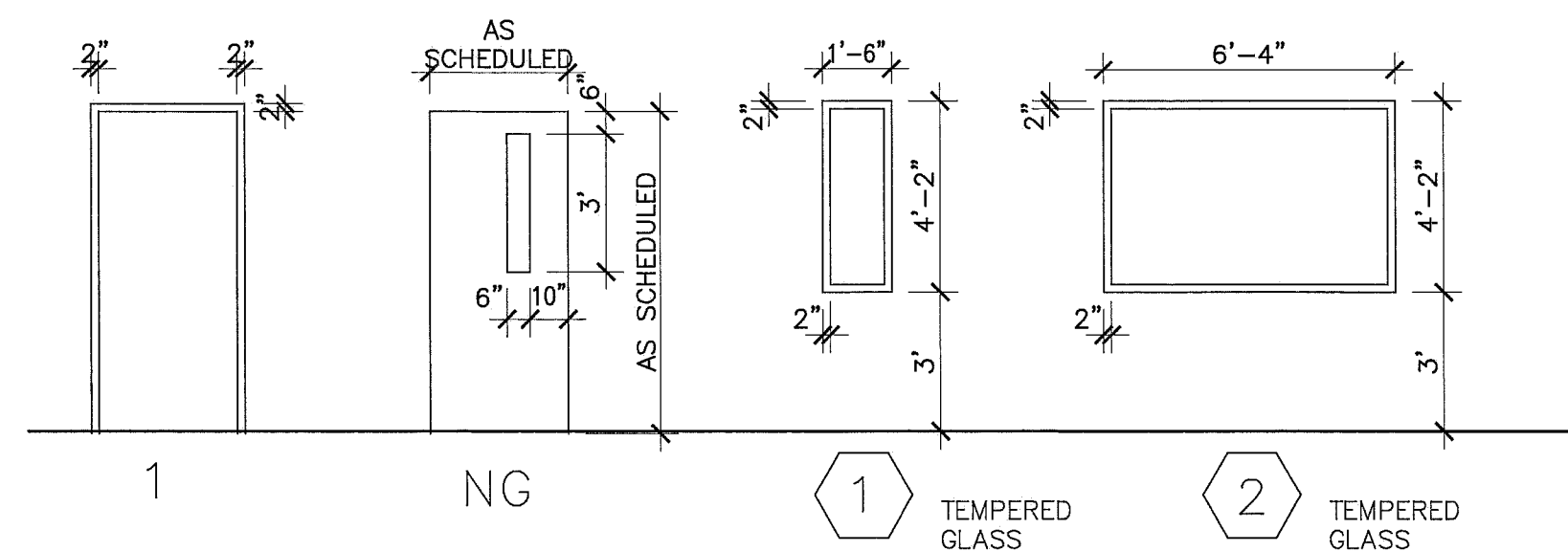

A1 DOOR AND WINDOW ELEVATIONS

1/4" = 1'-0"

REV.	DESCRIPTION	DATE
0	ISSUED FOR CONSTRUCTION	3/12/12

ISSUED FOR CONSTRUCTION
3/12/12

CURRENT ISSUE STATUS:

PROJECT NORTH

LICENSED ARCHITECT
CAROL F. GILLIS
No. 2841
Carol F. Gillis
STATE OF MAINE

DESIGN GROUP COLLABORATIVE
ARCHITECTURE
DESIGN + PLANNING

22 FREE STREET
PORTLAND, MAINE 04101
(207) 699-3300

MAINE MEDICAL CENTER
OB TRIAGE RENOVATIONS
PORTLAND, MAINE

PLANS AND SCHEDULES

SHEET TITLE:	DATE:	GRAPHIC SCALE:
	3/12/12	0"
SCALE:	AS NOTED	
PROJECT NO.:	10010	SHEET No.:
DRAWN BY:	CFG	
A/E OF RECORD:	CFG	

AE 102