

1 SECTION DETAIL OF PEDESTRIAN BRIDGE WEST PIER AT GRID LINE 10.9 3/4" = 1'-0"

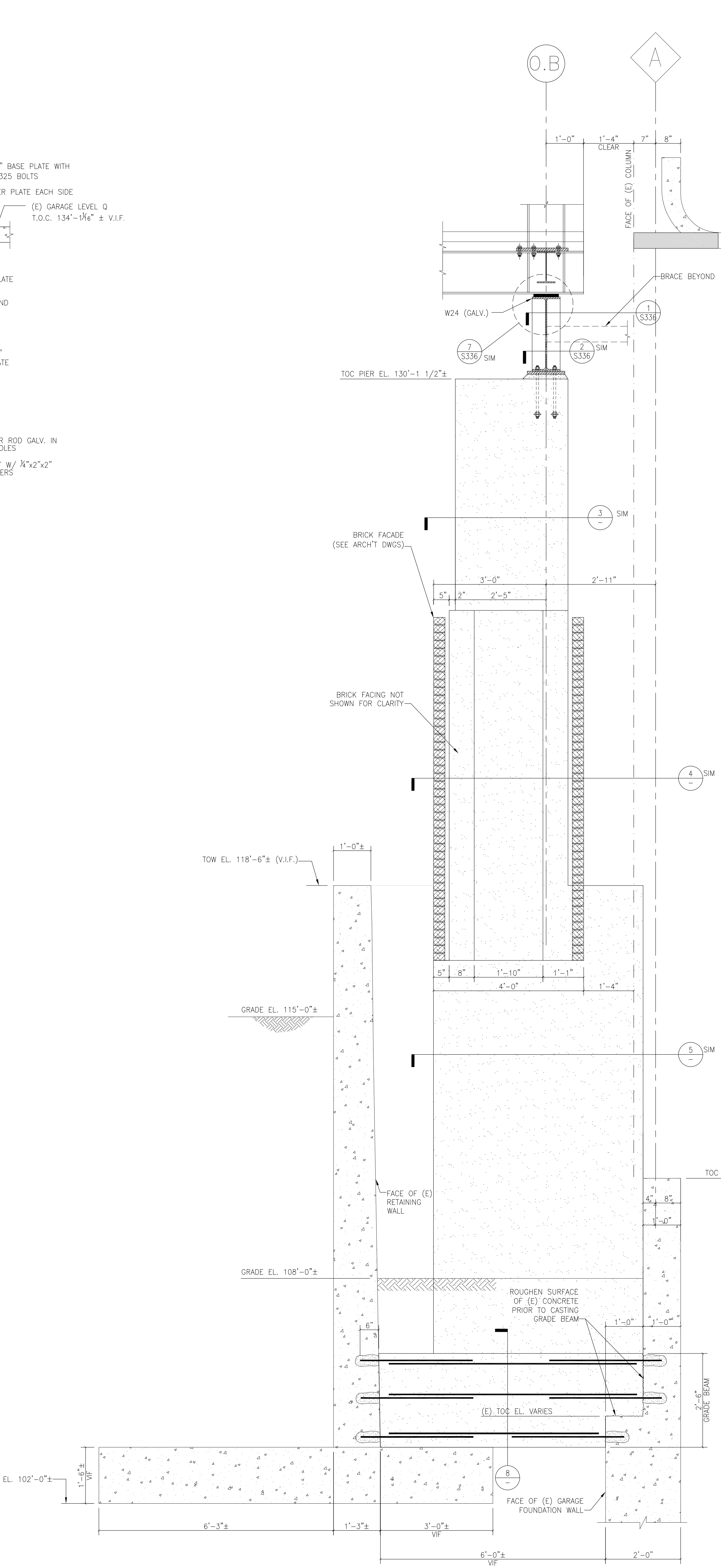

2 SECTION DETAIL OF PEDESTRIAN BRIDGE EAST PIER AT GRID LINE 8.15 3/4" = 1'-0"

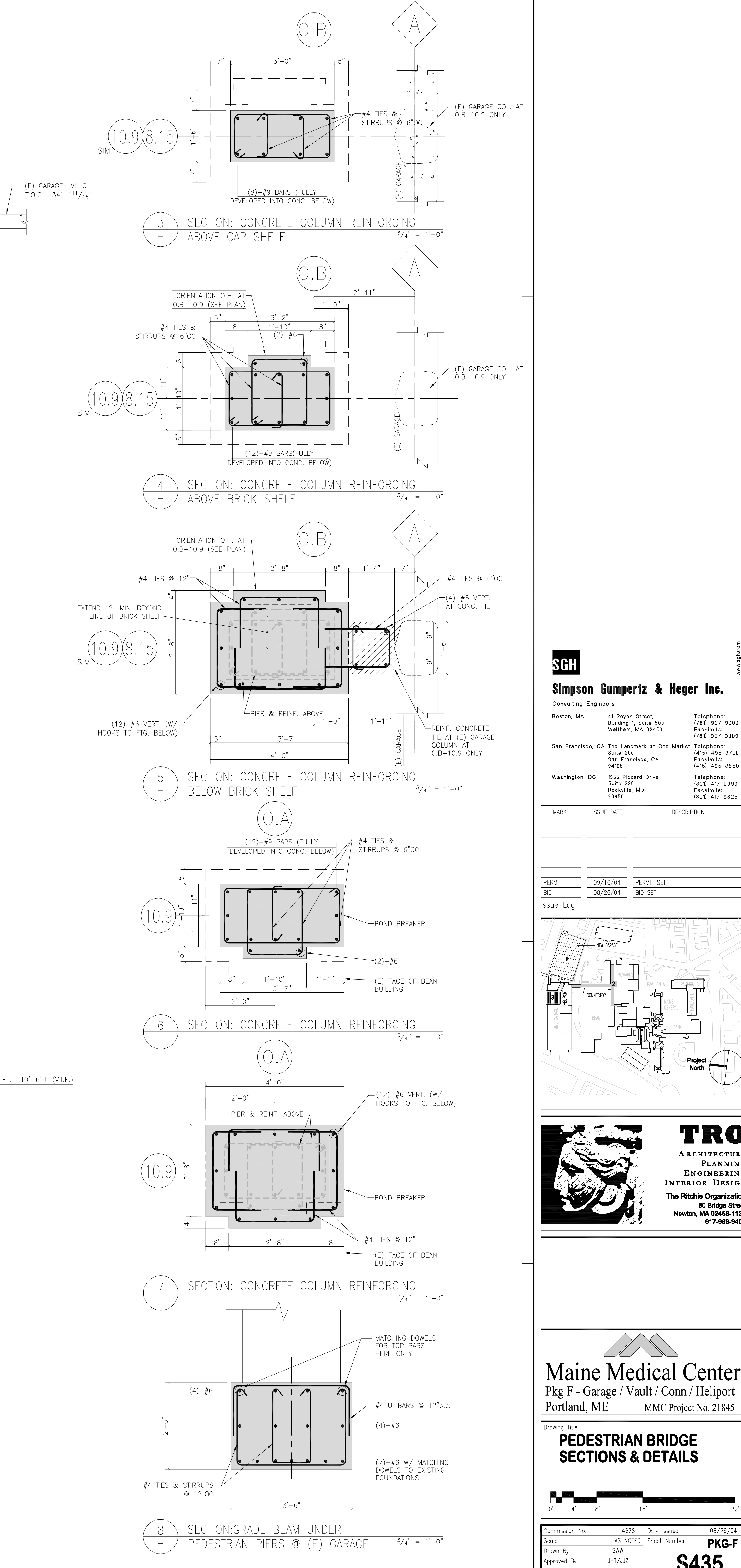

3 SECTION: CONCRETE COLUMN REINFORCING ABOVE CAP SHELF 3/4" = 1'-0"

4 SECTION: CONCRETE COLUMN REINFORCING ABOVE BRICK SHELF 3/4" = 1'-0"

5 SECTION: CONCRETE COLUMN REINFORCING BELOW BRICK SHELF 3/4" = 1'-0"

6 SECTION: CONCRETE COLUMN REINFORCING 3/4" = 1'-0"

7 SECTION: CONCRETE COLUMN REINFORCING 3/4" = 1'-0"

8 SECTION: GRADE BEAM UNDER PEDESTRIAN PIERS @ (E) GARAGE 3/4" = 1'-0"

**SGH**  
**Simpson Gumpertz & Heger Inc.**  
 Consulting Engineers  
 Boston, MA 41 Bayon Street, Telephone: (781) 307 9000  
 Building 1, Suite 500 Fax: (781) 307 9000  
 Waltham, MA 02455  
 San Francisco, CA The Landmark at One Market, Telephone: (415) 398 3700  
 Suite 600 San Francisco, CA Fax: (415) 398 3550  
 94105  
 Washington, DC 1355 Ploard Drive, Telephone: (301) 417 0999  
 Suite 228 Rockville, MD Fax: (301) 417 9825  
 20850

MARK	ISSUE DATE	DESCRIPTION
PERMIT	09/16/04	PERMIT SET
BID	08/26/04	BID SET

ISSUE Log

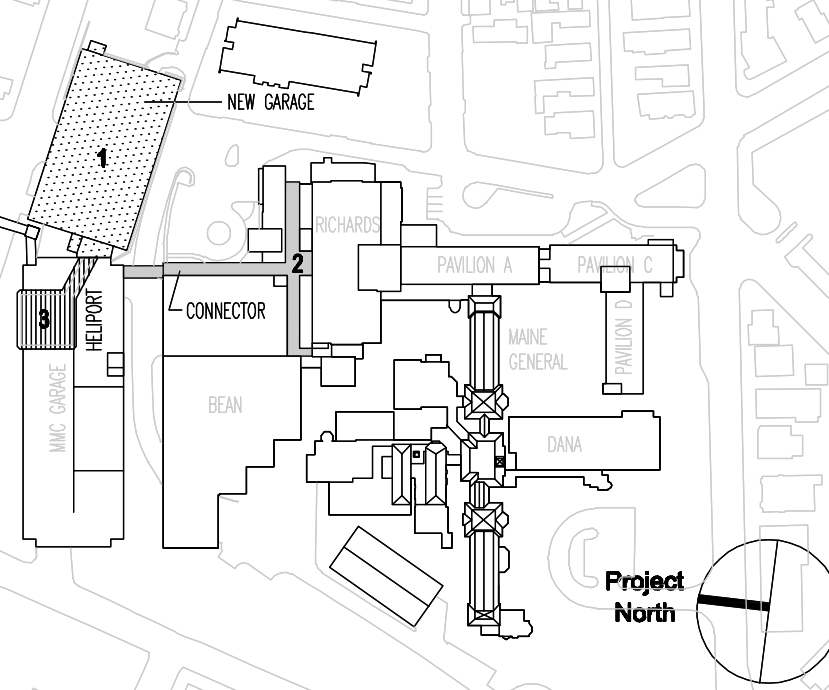

**TRO**  
**ARCHITECTURAL PLANNING ENGINEERING INTERIOR DESIGN**  
 The Ritchie Organization  
 80 Bridge Street  
 Newton, MA 02459-1154  
 617-869-9400

**Maine Medical Center**  
 Pkg F - Garage / Vault / Conn / Heliport  
 Portland, ME MMC Project No. 21845

**PEDESTRIAN BRIDGE SECTIONS & DETAILS**

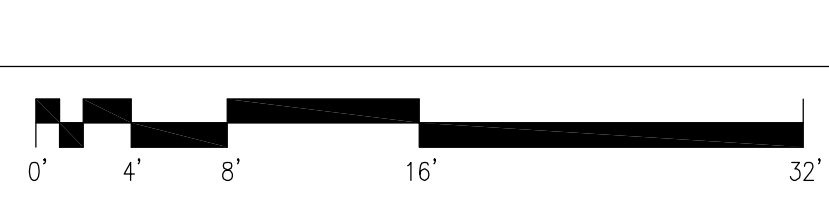

Commission No.	4678	Date Issued	08/26/04
Scale	AS NOTED	Sheet Number	PKG-F
Drawn By	SWW		S435
Approved By	JHT/JLT		
Filename	S330		