

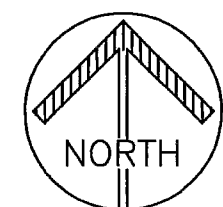

5/25/04

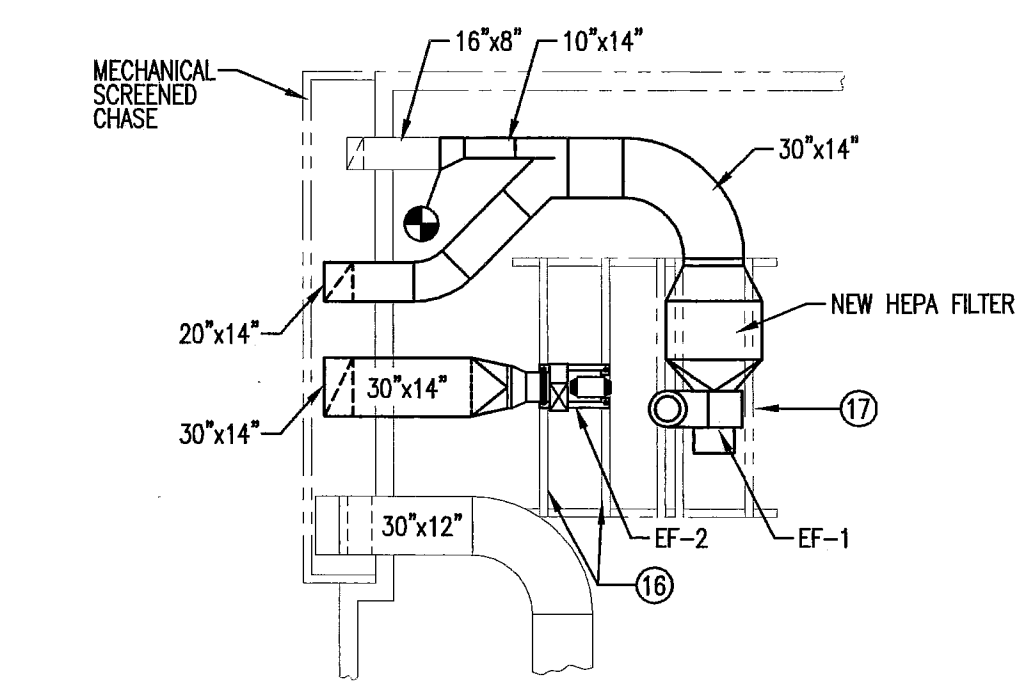

ISOLATION EXHAUST
TO ROOF

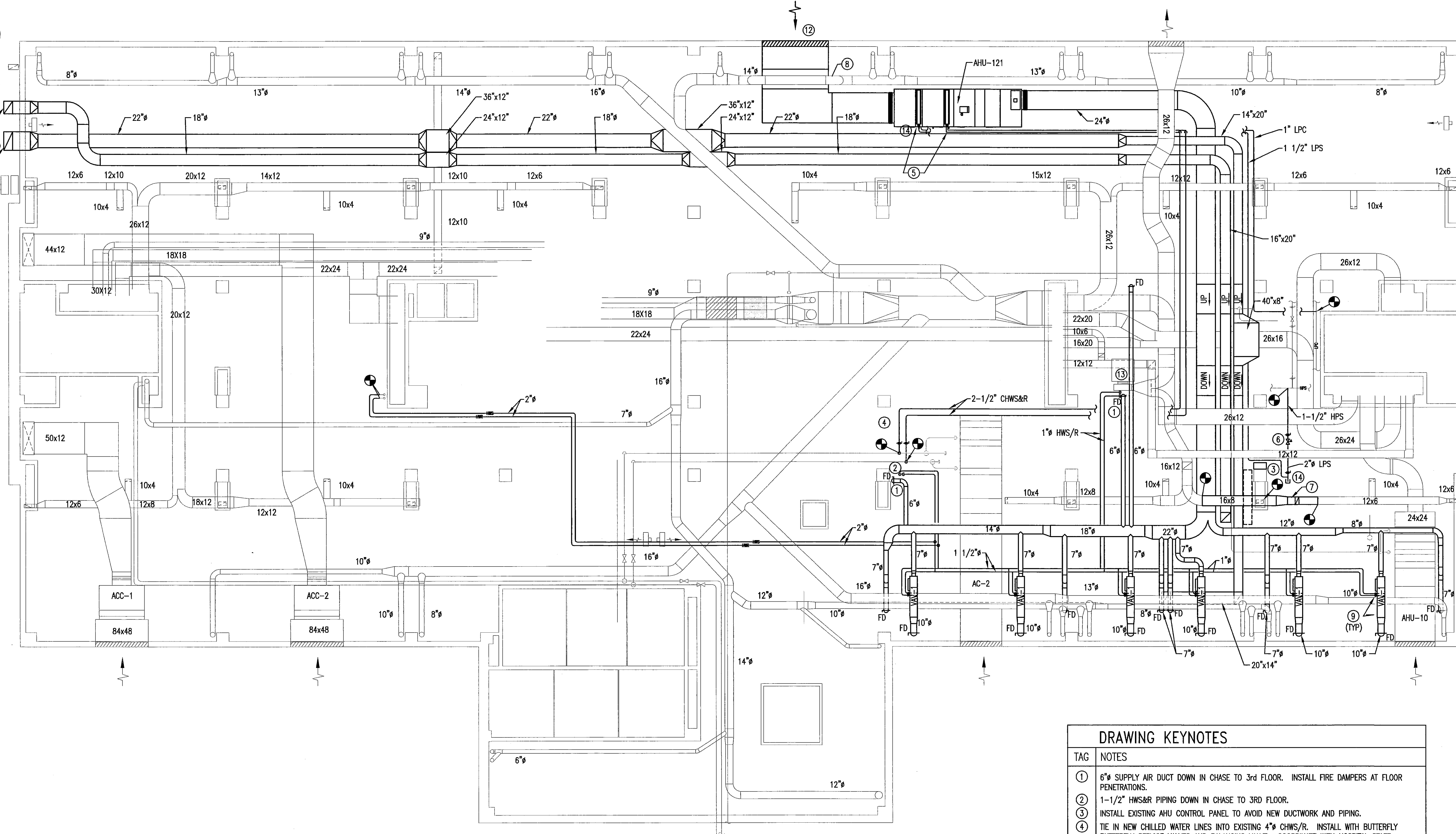

ROOF PART. PLAN
SCALE: 1/8"=1'-0"

TAG	NOTES
①	6" SUPPLY AIR DUCT DOWN IN CHASE TO 3rd FLOOR. INSTALL FIRE DAMPERS AT FLOOR PENETRATIONS.
②	1-1/2" HWS&R PIPING DOWN IN CHASE TO 3RD FLOOR.
③	INSTALL EXISTING AHU CONTROL PANEL TO AVOID NEW DUCTWORK AND PIPING.
④	TIE IN NEW CHILLED WATER LINES INTO EXISTING 4" CHWS/R. INSTALL WITH BUTTERFLY SERVICE VALVES AND BALANCING VALVE. COORDINATE WITH HOSPITAL STAFF TO PROVIDE SUFFICIENT PRESSURE AND FLOW.
⑤	SEE AHU COIL DETAILS FOR STEAM PREHEAT AND CHILLED WATER COIL HOOK-UP.
⑥	SEE STEAM PRESSURE REDUCING STATION DETAIL FOR STEAM PIPING AND SPECIALTY HOOK-UP.
⑦	REINSTALL DUCTWORK TIGHT TO CEILING TO AVOID MAINTENANCE ACCESS CORRIDOR.
⑧	REINSTALL INDUCTION AIR DUCT TO AVOID OUTSIDE AIR DUCT FOR AHU-121. SPRINKLER TO BE RELOCATED TO PROVIDE FIRE PROTECTION COVERAGE OVER DUCT.
⑨	SEE VAV TERMINAL HOT WATER HEATING COIL PIPING HOOK-UP (TYP).
⑩	30"x14" TOILET EXHAUST THROUGH MECH CHASE TO ROOF. CONTRACTOR TO VERIFY ROUTING OF DUCT. DUCT TO TIE INTO NEW EF-2 ON ROOF.
⑪	RUN IN SCREENED CHASEWAY ON BUILDING EXTERIOR. CONTRACTOR TO VERIFY ROUTING OF DUCT. DUCT TO TIE IN WITH EXISTING ISOLATION EXHAUST ON ROOF. TIE INTO NEW HEPA FILTER AND NEW EF-1.
⑫	72" L x 40" W EXTERIOR AIR INTAKE LOUVER L-1. SEE SPECIFICATION FOR CAPACITY AND DESCRIPTION.
⑬	6" SUPPLY AIR AND 1" HWS/R TO 4th FLOOR MED. ROOM. INSTALL FIRE DAMPER AT DUCTWORK FLOOR PENETRATION.
⑭	PROVIDE END OF MAIN STEAM DRIP IN LOCATION INDICATED AND AT EACH UPWARD CHANGE IN ELEVATION IN DIRECTION OF STEAM FLOW.
⑮	TIE REHEAT WATER LINES INTO EXISTING 2 1/2" HWS/R. CONTRACTOR TO VERIFY SUPPLY AND RETURN LINES. COORDINATE WITH HOSPITAL STAFF TO PROVIDE SUFFICIENT PRESSURE AND FLOW.
⑯	MOUNT NEW EF-2 ON NEW SUPPORT STEEL. STEEL TO BE SECURELY FASTENED TO EXISTING ROOF CURBS.
⑰	MOUNT NEW EF-1 ON EXISTING SUPPORT STEEL. MOUNT HEPA FILTER AND FAN SECURELY ACCORDING TO SPECIFICATIONS.

L:\24485\Cada\ComarDacs-25-04\25486M006.dwg May 24, 2004 - 4:18pm

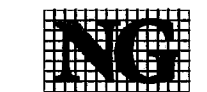

Neill and Gunter