

PERMIT ISSUED

City of Portland, Maine - Building or Use Permit Application

389 Congress Street, 04101 Tel: (207) 874-8703, Fax: (207) 874-8716

Permit No: 03-0763	Issue Date: JUL 11 2003	CBL: 053 C034001
-----------------------	----------------------------	---------------------

Location of Construction: 817 Congress St	Owner Name: Pagano Jean Wallace Revocable	Owner Address: 11 Little Bear Path CITY OF PORTLAND	Phone: 415-3531
Business Name:	Contractor Name: Paul Sieg	Contractor Address: 96 Hartley Street Portland	Phone: 2077728699
Lessee/Buyer's Name:	Phone:	Permit Type: Alterations - Multi Family	Zone: B26

Past Use: Multi Family	Proposed Use: Multi Family	Permit Fee: \$79.00	Cost of Work: \$7,770.00	CEO District: 2
Proposed Project Description: Repair Stairs and Wooden Fire Escape <i>Legal use: 12 Residential Dwelling units per microfiche</i>		FIRE DEPT: <input checked="" type="checkbox"/> Approved <input type="checkbox"/> Denied	INSPECTION: Use Group: R2 Type: 59 7/10/03	
Signature: <i>[Signature]</i>		Signature: <i>[Signature]</i>		
PEDESTRIAN ACTIVITIES DISTRICT (P.A.D.)				
Action: <input type="checkbox"/> Approved <input type="checkbox"/> Approved w/Conditions <input type="checkbox"/> Denied				
Signature: _____ Date: _____				

Permit Taken By: gad	Date Applied For: 06/27/2003	Zoning Approval		
-------------------------	---------------------------------	------------------------	--	--

<p>1. This permit application does not preclude the Applicant(s) from meeting applicable State and Federal Rules.</p> <p>2. Building permits do not include plumbing, septic or electrical work.</p> <p>3. Building permits are void if work is not started within six (6) months of the date of issuance. False information may invalidate a building permit and stop all work..</p>	<p>Special Zone or Reviews</p> <p><input type="checkbox"/> Shoreland</p> <p><input type="checkbox"/> Wetland</p> <p><input type="checkbox"/> Flood Zone</p> <p><input type="checkbox"/> Subdivision</p> <p><input type="checkbox"/> Site Plan</p> <p>Maj <input type="checkbox"/> Minor <input type="checkbox"/> MM <input type="checkbox"/></p>	<p>Zoning Appeal</p> <p><input type="checkbox"/> Variance</p> <p><input type="checkbox"/> Miscellaneous</p> <p><input checked="" type="checkbox"/> Conditional Use</p> <p><input type="checkbox"/> Interpretation</p> <p><input type="checkbox"/> Approved</p> <p><input type="checkbox"/> Denied</p>	<p>Historic Preservation</p> <p><input checked="" type="checkbox"/> Not in District or Landmark</p> <p><input type="checkbox"/> Does Not Require Review</p> <p><input type="checkbox"/> Requires Review</p> <p><input type="checkbox"/> Approved</p> <p><input type="checkbox"/> Approved w/Conditions</p> <p><input type="checkbox"/> Denied</p>
	<p>SCANNED</p> <p><i>Not to increase the existing footprint unless permitted under File & Bldg Codes</i></p> <p>Date: <i>7/1/03</i></p>		<p>Date: <i>[Signature]</i></p>

CERTIFICATION

I hereby certify that I am the owner of record of the named property, or that the proposed work is authorized by the owner of record and that I have been authorized by the owner to make this application as his authorized agent and I agree to conform to all applicable laws of this jurisdiction. In addition, if a permit for work described in the application is issued, I certify that the code official's authorized representative shall have the authority to enter all areas covered by such permit at any reasonable hour to enforce the provision of the code(s) applicable to such permit.

SIGNATURE OF APPLICANT _____ ADDRESS _____ DATE _____ PHONE _____

RESPONSIBLE PERSON IN CHARGE OF WORK, TITLE _____ DATE _____ PHONE _____

DISPLAY THIS CARD ON PRINCIPAL FRONTAGE OF WORK CITY OF PORTLAND

Please Read Application And Notes, If Any, Attached

BUILDING DEPARTMENT

PERMIT

Permit Number: **PERMIT ISSUED**

This is to certify that Pagano, Jean Wallace Revocatory Paul S JUL 11 2003
has permission to Repair Stairs and Wooden Fire escape
AT 817 Congress St 053 C034001 CITY OF PORTLAND

provided that the person or persons, firm or corporation accepting this permit shall comply with all of the provisions of the Statutes of Maine and of the ordinances of the City of Portland regulating the construction, maintenance and use of buildings and structures, and of the application on file in this department.

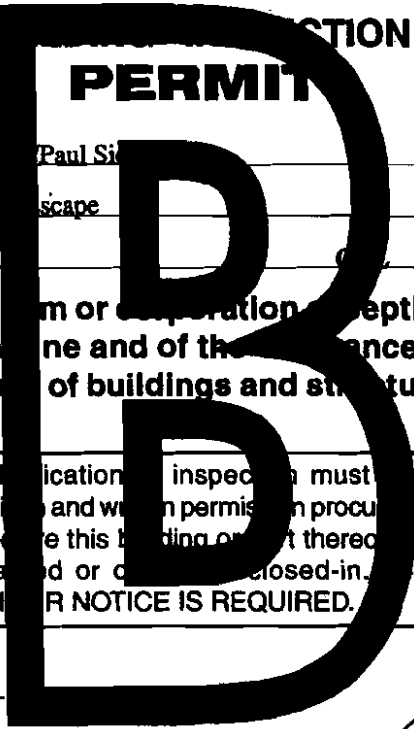

Apply to Public Works for street line and grade if nature of work requires such information.

Notification of inspection must be given and work on permit must be completed before this building or part thereof is occupied or closed-in. **HEAVY NOTICE IS REQUIRED.**

A certificate of occupancy must be procured by owner before this building or part thereof is occupied.

OTHER REQUIRED APPROVALS

Fire Dept. [Signature]
Health Dept. _____
Appeal Board _____
Other _____
Department Name _____

[Signature]
Director - Building & Inspection Services

PENALTY FOR REMOVING THIS CARD

City of Portland, Maine - Building or Use Permit

389 Congress Street, 04101 Tel: (207) 874-8703, Fax: (207) 874-8716

Permit No: 03-0763	Date Applied For: 06/27/2003	CBL: 053 C034001
-----------------------	---------------------------------	---------------------

Location of Construction: 817 Congress St	Owner Name: Pagano Jean Wallace Revocable	Owner Address: 11 Little Bear Path	Phone: () 415-3531
Business Name:	Contractor Name: Paul Sieg	Contractor Address: 96 Hartley Street Portland	Phone: (207) 772-8699
Lessee/Buyer's Name	Phone:	Permit Type: Alterations - Multi Family	

Proposed Use: Multi Family - to remain 12 residential dwelling units	Proposed Project Description: Repair Stairs and Wooden Fire Escape
--	--

Dept: Zoning **Status:** Approved with Conditions **Reviewer:** Marge Schmuckal **Approval Date:** 07/01/2003**Note:** **Ok to Issue:**

- 1) The footprint of the existing decks and stairs shall not be increased unless to the minimum required under the fire and building codes.
- 2) This is NOT an approval for an additional dwelling unit. You SHALL NOT add any additional kitchen equipment including, but not limited to items such as stoves, microwaves, refrigerators, or kitchen sinks, etc. Without special approvals.
- 3) This property shall remain a twelve (12) family dwelling. Any change of use shall require a separate permit application for review and approval.

Dept: Building **Status:** Approved with Conditions **Reviewer:** Mike Nugent **Approval Date:** 07/10/2003**Note:** **Ok to Issue:**

- 1) All new stairs shall have solid risers. All guards must 42 inches w/openings less than 4 inches
- 2) The fire escape discharge shall comply with the Fire Escape standards of Section 1025. Of th BOCA code and shall not be a ladder.

Dept: Fire **Status:** Approved with Conditions **Reviewer:** Lt. MacDougal **Approval Date:** 07/03/2003**Note:** **Ok to Issue:**

- 1) handrails shall be graspable with a diameter of 1 1/4 to 2" in width
- 2) guards shall be a minimum of 42" in height
- 3) the fire escape shall discharge at ground level
- 4) a fire alarm system shall be installed in accordance with NFPA 72 standards

Comments:

7/9/2003-mjn: Need more info, called contractor

City of Portland, Maine - Building or Use Permit

389 Congress Street, 04101 Tel: (207) 874-8703, Fax: (207) 874-8716

Permit No: 03-0763	Date Applied For: 06/27/2003	CBL: 053 C034001
------------------------------	--	----------------------------

Location of Construction: 817 Congress St	Owner Name: Pagano Jean Wallace Revocable	Owner Address: 11 Little Bear Path	Phone: () 415-3531
Business Name:	Contractor Name: Paul Sieg	Contractor Address: 96 Hartley Street Portland	Phone: (207) 772-8699
Lessee/Buyer's Name	Phone:	Permit Type: Alterations - Multi Family	

Proposed Use: Multi Family - to remain 12 residential dwelling units	Proposed Project Description: Repair Stairs and Wooden Fire Escape
--	--

Dept: Zoning **Status:** Approved with Conditions **Reviewer:** Marge Schmuckal **Approval Date:** 07/01/2003**Note:** **Ok to Issue:**

- 1) The footprint of the existing decks and stairs shall not be increased unless to the minimum required under the fire and building codes.
- 2) This is NOT an approval for an additional dwelling unit. You SHALL NOT add any additional kitchen equipment including, but not limited to items such as stoves, microwaves, refrigerators, or kitchen sinks, etc. Without special approvals.
- 3) This property shall remain a twelve (12) family dwelling. Any change of use shall require a separate permit application for review and approval.

Dept: Building **Status:** Approved with Conditions **Reviewer:** Mike Nugent **Approval Date:** 07/10/2003**Note:** **Ok to Issue:**

- 1) All new stairs shall have solid risers. All guards must 42 inches w/openings less than 4 inches
- 2) The fire escape discharge shall comply with the Fire Escape standards of Section 1025. Of th BOCA code and shall not be a ladder.

Dept: Fire **Status:** Approved with Conditions **Reviewer:** Lt. MacDougal **Approval Date:** 07/03/2003**Note:** **Ok to Issue:**

- 1) handrails shall be graspable with a diameter of 1 1/4 to 2" in width
- 2) guards shall be a minimum of 42" in height
- 3) the fire escape shall discharge at ground level
- 4) a fire alarm system shall be installed in accordance with NFPA 72 standards

Comments:

07/09/2003-mjn: Need more info, called contractor

819 CONGRESS ST. ~~██████████~~

WORK TO BE DONE.

- ① REBUILD FOUR LOWER KNEE BRACES FROM 4x4 P.T.
- ② ATTACH TO WALL STUDS W/ 3 to 4 - 1/2" x 8 1/2" LAG SCREWS
- ③ REBUILD TWO LOWER PLATFORMS W/ 2x6 P.T. W/ JOIST HANGERS. 5/4 x 6" P.T. FOR DECKING AND TREADS. SCREWED W/ 2 1/2" GALV. SCREWS.
DIMENSIONS OF PLATFORMS TO REMAIN SAME AS EXISTING.
- ④ INSTALL NEW 4x4 NEWEL POSTS. LGTH. INCREASED TO BRING ~~██████████~~ UP TO ~~██████████~~". POSTS ATTACHED W/ 4 - 5/16" x 6" LAG SCREWS W/ WASHERS
- ⑤ 2x4 P.T. TOP RAIL EDGES ROUNDED OVER. BALISTERS 1 1/2 x 1 1/2 SQ. P.T. PAINTED. 3"-4" O.C.
- ⑥ WORK TO FIRE ESCAPE NOT GOING HIGHER THAN MIDDLE PLATFORM AND RAILING.

32"

819 CONGRESS ST. FIRE ESCAPE

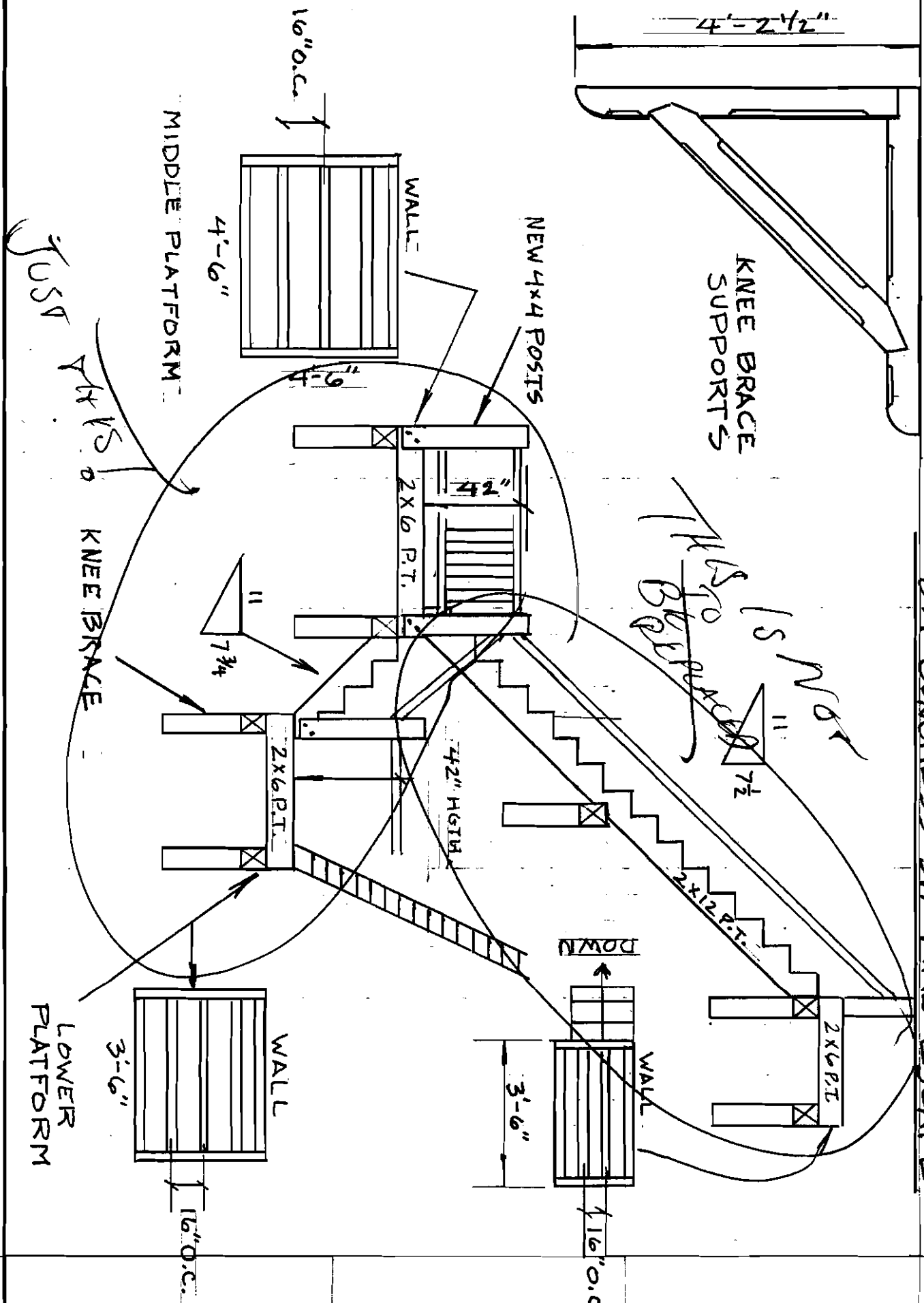

LOT FRONT

CONGRESS ST.

BRICK SIDEWALK

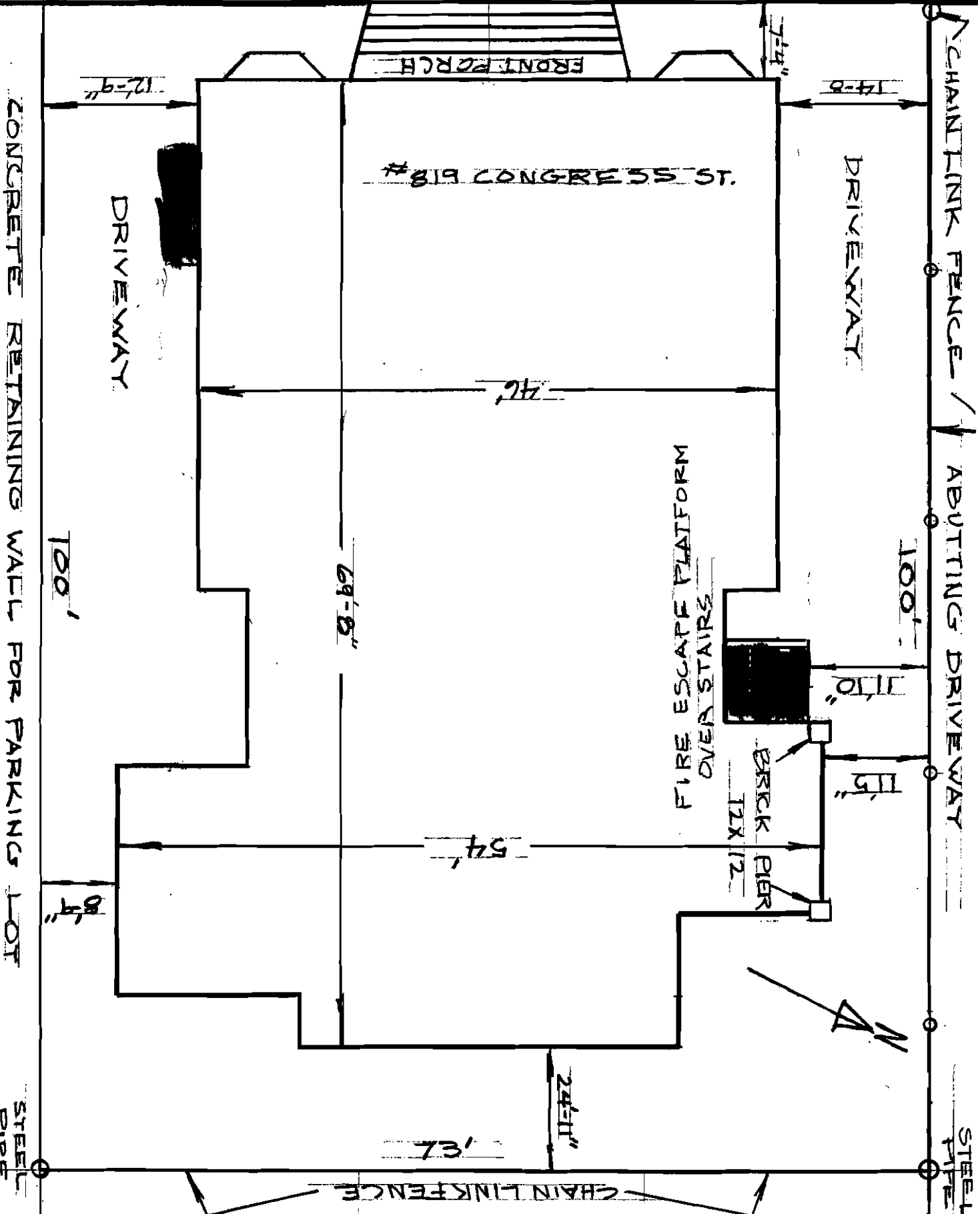

CONCRETE RETAINING WALL FOR PARKING LOT

STEEL PIPE

CHAIN LINK FENCE / ABUTTING DRIVEWAY

STEEL PIPE

FRONT PORCH

#819 CONGRESS ST.

DRIVEWAY

DRIVEWAY

FIRE ESCAPE PLATFORM OVER STAIRS

BRICK PIERS 12X12



12'-9"

14'-8"

7'-4"

7'-6"

69'-8"

100'

11'-0"

11'-5"

54'

8'-4"

24'-11"

73'

CHAIN LINK FENCE

819 CONGRESS ST.

FRONT ENTRANCE STAIRS.

WORK TO BE DONE.

- ① REPLACING PLATFORM AND TREADS WITH $5/4$ " x 6" PRESSURE TREATED LUMBER.
- ② INSTALL LONGER 4x4 P.T. NEWAL TO BRING TOP HAND RAIL UP, TO MEET BUILDING CODE OF 40" TOP RAIL HGTH. FROM NEW TREAD.
- ③ INSTALL NEW HANDRAIL USING 2x4 P.T. ROUNDED OVER, SANDED SMOOTH, ATTACHED W/ 2 - $5/16$ " x 6" LAG SCREWS.
- ④ $5/4$ " DECKING AND TREADS SCREWED DOWN W/ 2 $1/2$ " GALV. SCREWS
- ⑤ BALISTERS ARE $1\frac{1}{2}$ " x $1\frac{1}{2}$ " P.T. SPACED 3"-4" O.C. ATTACHED W/ GALV. SCREWS.
- ⑥ ALL DIMENSIONS OF STAIRS STAYING THE SAME AS EXISTING FRONT STAIRS.

03-0763

All Purpose Building Permit Application

If you or the property owner owes real estate or personal property taxes or user charges on any property within the City, payment arrangements must be made before permits of any kind are accepted.

Location/Address of Construction: <u>819 CONGRESS ST.</u>		
Total Square Footage of Proposed Structure	Square Footage of Lot	
Tax Assessor's Chart, Block & Lot Chart# <u>053</u> Block# <u>C</u> Lot# <u>034</u>	Owner: <u>JEAN PAGANO</u> <u>40 ED CLARK</u>	Telephone: <u>415-3531</u>
Lessee/Buyer's Name (if Applicable)	Applicant name, address & telephone: <u>ED CLARK</u> <u>23 GEORGE ST.</u> <u>415-3531</u>	Cost Of Work: \$ <u>7770.</u> Fee: \$ <u>79.00</u>
Current use: <u>APT. BUILDING</u>		
If the location is currently vacant, what was prior use: <u>Apt. Building</u>		
Approximately how long has it been vacant: <u>NEVER BEEN VACANT</u>		
Proposed use: <u>REPAIR STAIRS ON LEFT OF BUILDING</u>		
Project description: <u>REPAIR WOODEN FIRE ESCAPE ON BOTH SIDE OF BUILDING. REPAIR FRONT STAIRS</u>		
Contractor's name, address & telephone: <u>PAUL L. SIEG</u> <u>96 HARTLEY ST.</u> <u>772-8699</u>		
Who should we contact when the permit is ready: <u>PAUL SIEG</u>		
Mailing address: <u>96 HARTLEY ST.</u> <u>PORTLAND ME, 04103</u>		
We will contact you by phone when the permit is ready. You must come in and pick up the permit and review the requirements before starting any work, with a Plan Reviewer. A stop work order will be issued and a \$100.00 fee if any work starts before the permit is picked up. PHONE: <u>772-8699</u>		

IF THE REQUIRED INFORMATION IS NOT INCLUDED IN THE SUBMISSIONS THE PERMIT WILL BE AUTOMATICALLY DENIED AT THE DISCRETION OF THE BUILDING/PLANNING DEPARTMENT, WE MAY REQUIRE ADDITIONAL INFORMATION IN ORDER TO APPROVE THIS PERMIT.

I hereby certify that I am the Owner of record of the named property, or that the owner of record authorized the proposed work and that I have been authorized by the owner to make this application as his/her authorized agent. I agree to conform to all applicable codes of this jurisdiction. In addition, if a permit for work described in this application is issued, I certify that the Code Officer's authorized representative shall have the authority to enter all areas covered by this permit at any reasonable hour to enforce the provisions of the codes applicable to this permit.

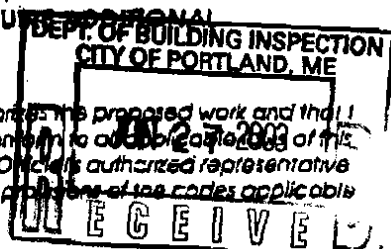

Signature of applicant:	Date: <u>6.25.03</u>
-------------------------	----------------------

This is NOT a permit, you may not commence ANY work until the permit is issued. If you are in a Historic District you may be subject to additional permitting and fees with the Planning Department on the 4th floor of City Hall

819 CONGRESS ST. ~~2nd FL. FIN~~

~~REAR DECK LANDING~~, WORK TO BE DONE.

- ① REPLACE 2x8 JOISTS WHERE NEEDED
W/ 2x8 P.T. 16" O.C. W/ JOIST HANGERS
- ② REPLACE DECKING W/ 5/4x6 P.T.
- ③ INSTALL NEW 4x4 CORNER POSTS,
ATTACHED W/ 3-4 5/16x6" LAG SCREWS.
- ④ INSTALL NEW RAILING W/ 2x4 P.T. AND
1/2x1/2 SQ. P.T. BALISTERS 3" to 4" O.C.
TOP RAIL EDGES ROUNDED OVER.
DIMENSIONS OF LANDING ARE
STAYING THE SAME. NEW RAILING
42" HGTH. FROM DECK TO TOP OF
RAILING.

2ND FL. DECK RAILING

NEW
4x4's

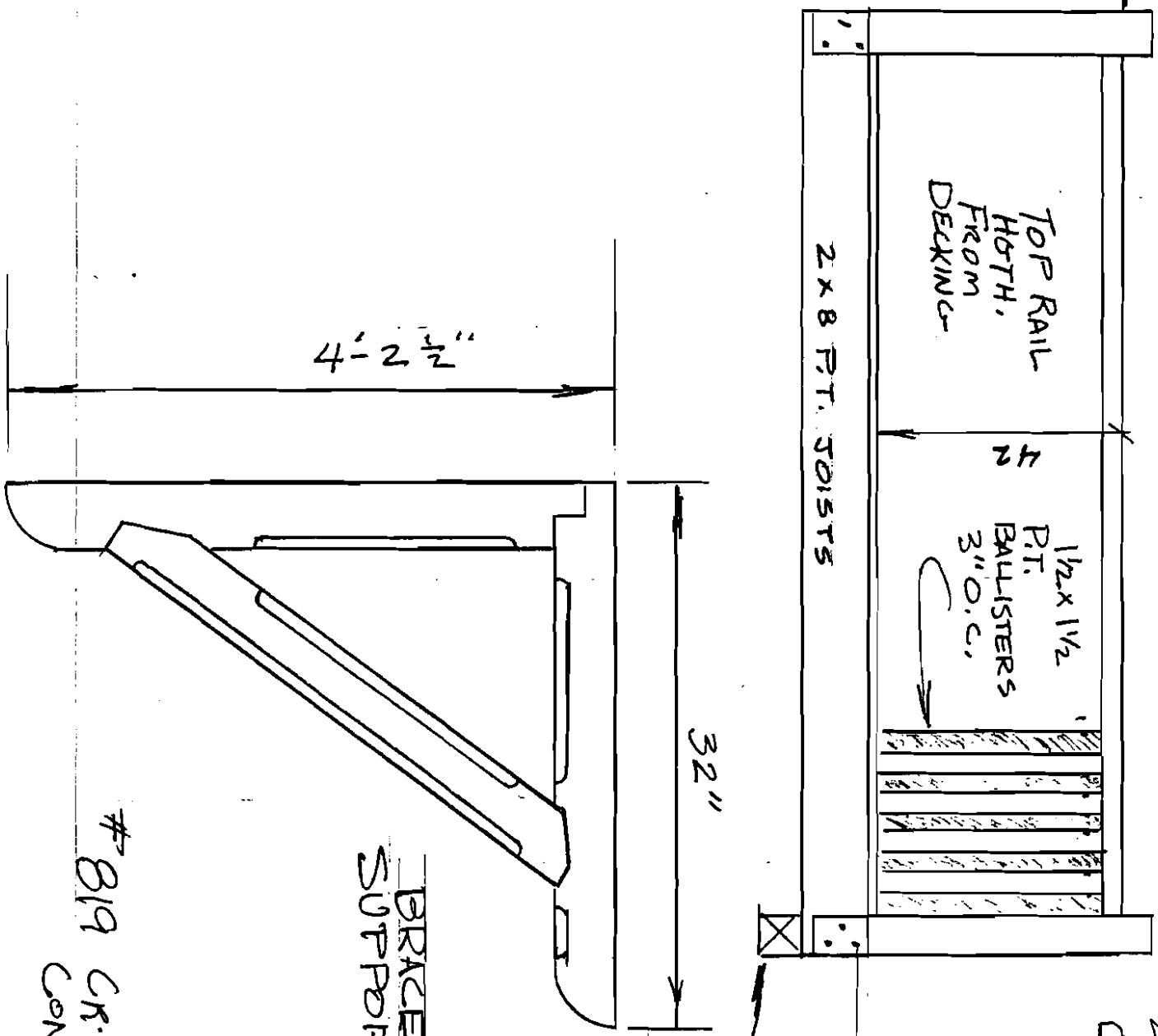

2x4 TOP RAIL WITH
2x4 ROUNDED
OVER
EDGES

3 - 5/16" X 6"

LAG SCREWS

BRACE
SUPPORT

BRACE
SUPPORT

4' - 2 1/2"

#819 CR.
CONGRESS ST

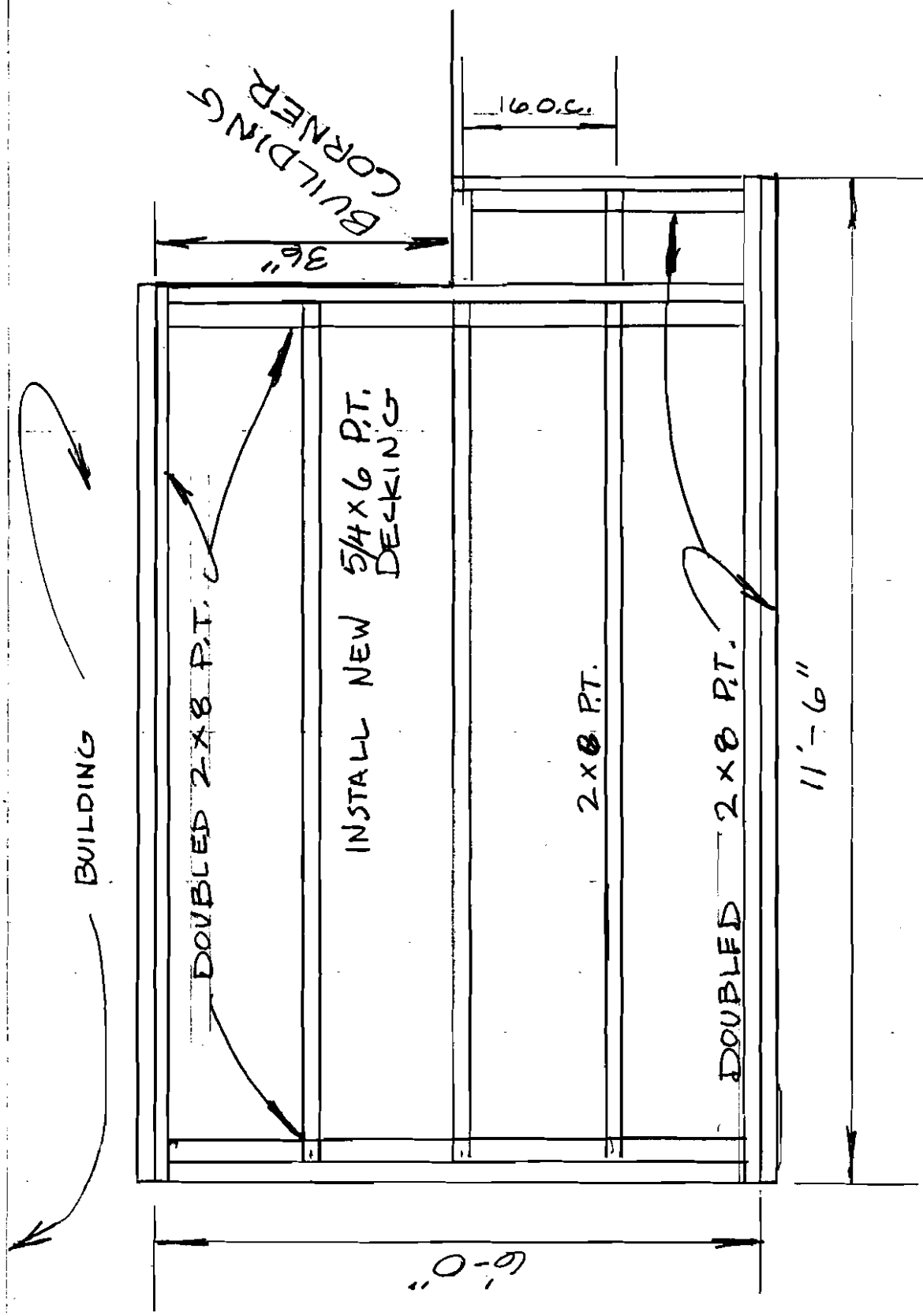

819 CONGRESS ST.

~~FRONT ENTRANCE STAIRS.~~

WORK TO BE DONE.

- ① REPLACING PLATFORM AND TREADS WITH $5/4$ " x 6 " PRESSURE TREATED LUMBER.
- ② INSTALL LONGER 4×4 P.T. NEWAL TO BRING TOP HAND RAIL UP, TO MEET BUILDING CODE OF 40 " TOP RAIL HGTH. FROM NEW TREAD.
- ③ INSTALL NEW HANDRAIL USING 2×4 P.T. ROUNDED OVER, SANDED SMOOTH, ATTACHED W/ $2 - 5/16$ " x 6 " LAG SCREWS.
- ④ $5/4$ " DECKING AND TREADS SCREWED DOWN W/ $2 1/2$ " GALV. SCREWS
- ⑤ BALISTERS ARE $1 1/2$ " x $1 1/2$ " P.T. SPACED $3 - 4$ " O.C. ATTACHED W/ GALV. SCREWS.
- ⑥ ALL DIMENSIONS OF STAIRS STAYING THE SAME AS EXISTING FRONT STAIRS. RAILING HGTH. 42 " FROM DECKING TO TOP OF RAIL.

TOP VIEW OF STAIRS

15-4

74 1/4"

5/4 X 6" P.T.

DOWN

4X4 NEWEL

HANDRAIL
DETAIL

2X4 P.T.
ROUNDED
OVER ON
TOP

2- 5/16 X 3"
LAG SCREWS

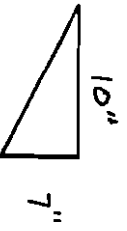

42" RAIL HGT.

4X4 NEWEL
P.T.

2- 3/8 X 6"
LAG SCREWS

1 1/2 X 1 1/2
BAJUSTER
P.T.
3" APART

*B19 CONGRESS ST.

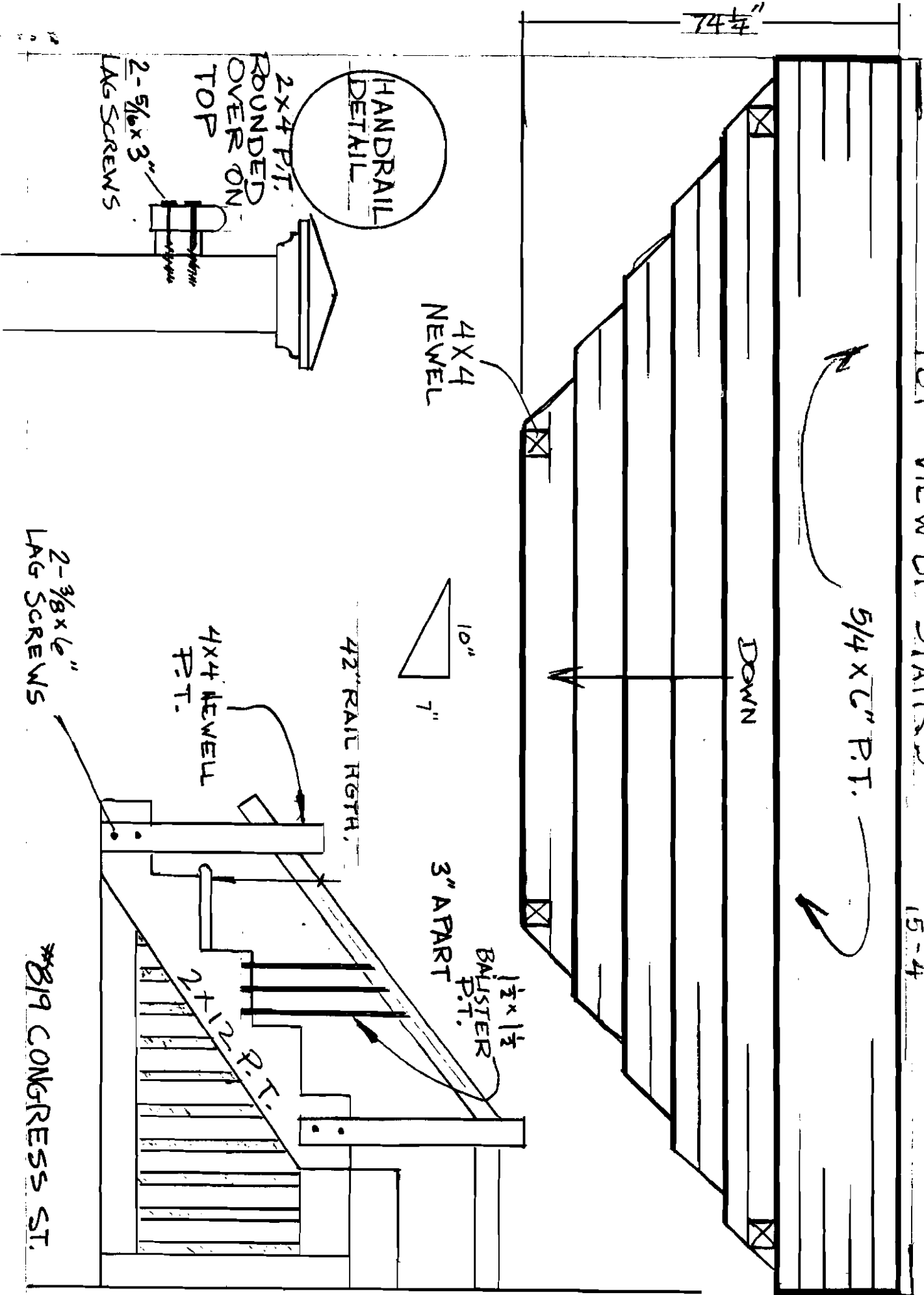

819 CONGRESS ST. ~~XXXXXXXXXX~~ ON
LEFT SIDE OF BUILDING.

WORK TO BE DONE.

- ① REPLACE OUTSIDE STAIR STRINGER AND SKIRT W/ 2X12 P.T. AND 1X12 P.T.
- ② REPLACE TOP DECK W/ 5/4 X 6 P.T.
- ③ REPLACE BOTTOM TREAD W/ 5/4 X 6 P.T.
- ④ REPLACE BOTH OUTSIDE NEWEL POSTS W/ 4X4 P.T., RAISING HGTH. FROM EXISTING 30 1/2" TO CODE OF 40" TOP OF RAIL HGTH.
3- 5/16" X 6" LAG SCREWS TO ATTACH NEWEL POSTS TO STRINGER. GALVANIZED SCREWS TO ATTACH BALISTERS. 2X10 STEEL JOIST TIES TO ATTACH STRINGER TO OUTSIDE JOIST OF PLATFORM.
- ⑤ TREADS FRONT EDGE ROUNDED OVER.
OVERHANG AT LEAST 3/4"
- ⑥ REPLACE FIRST PINE RISER (GRADE LEVEL) W/ 3/4" X 7" P.T.
- ⑦ REPLACE MISSING PICKETS W/ 1X3 P.T.
DIMENSIONS OF STAIRS ARE STAYING THE SAME.

DOWN VIEW OF STAIRS

819 CONGRESS SIDE STAIRS

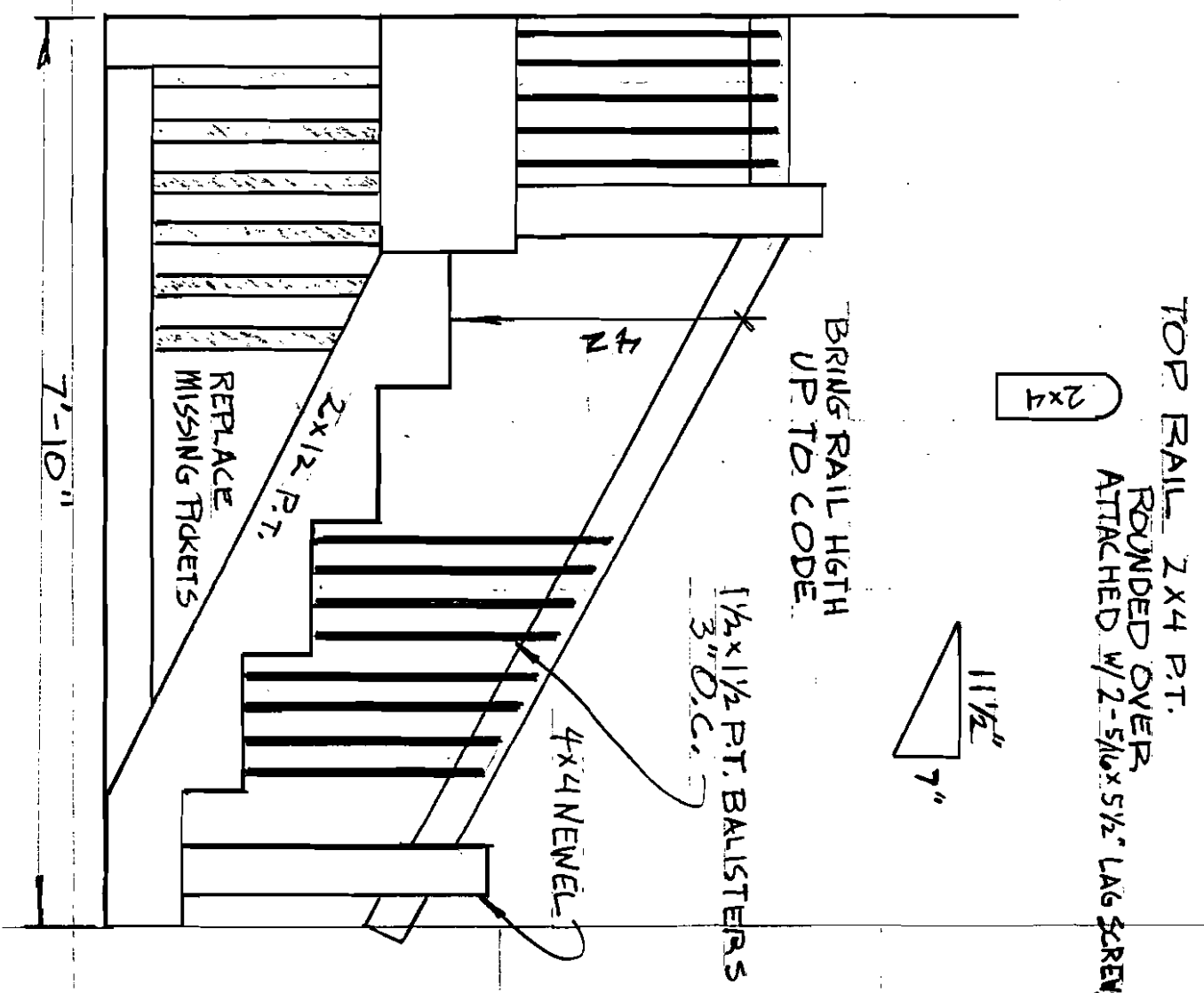
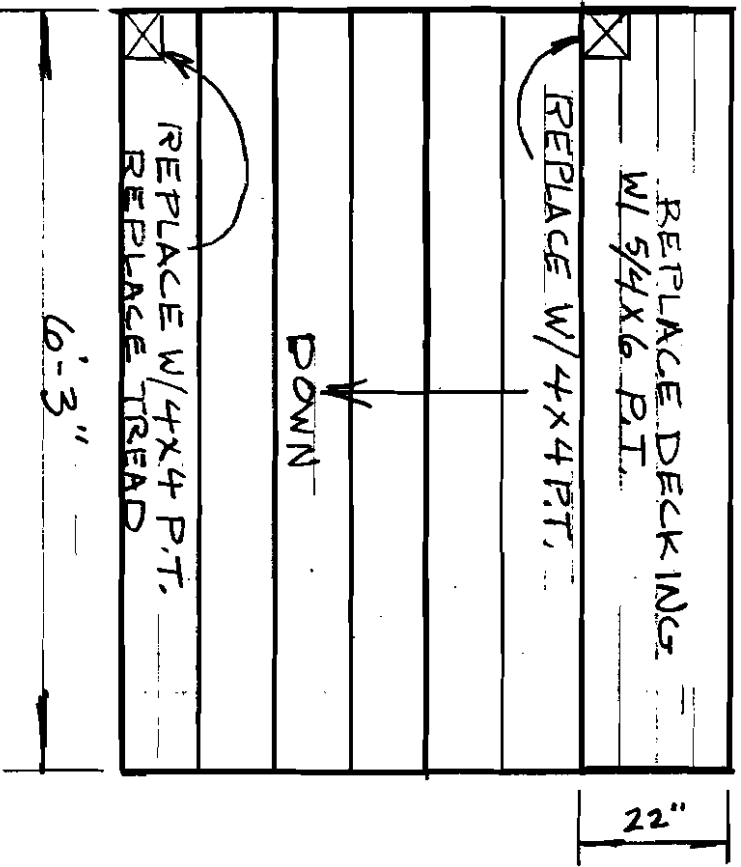

This page contains a detailed description of the Parcel ID you selected. Press the **New Search** button at the bottom of the screen to submit a new query.

Current Owner Information

Card Number 1 of 1
 Parcel ID 053 C034001
 Location 817 CONGRESS ST
 Land Use ELEVEN TO TWENTY FAMILY
 Owner Address PAGANO JEAN WALLACE REVOCABLE TRUST
 13 LITTLE BEAR PATH
 ORMOND BEACH FL 32174

Book/Page
 Legal 53-C-34-35
 CONGRESS ST 817-819
 7000 SF

Valuation Information

Land \$37,490 Building \$220,710 Total \$258,200

Building Information

Bldg #	Year Built	# Units	Bldg Sq. Ft.	Identical Units
1	1910	12	11119	1

Total Acres	Total Buildings	Sq. Ft.	Structure Type	Building Name
0.161	1	11119	APARTMENT - GARDEN	

Exterior/Interior Information

Section	Levels	Size	Use
1	81/81	2977	SUPPORT AREA
1	01/01	3016	APARTMENT
1	02/02	2929	APARTMENT
1	03/03	2197	APARTMENT

Height	Walls	Heating	A/C
7			
9	FRAME	HOT AIR	
9	FRAME	HOT AIR	
6	FRAME	HOT AIR	

Building Other Features

Line	Structure Type	Identical Units
2	PORCH - ENCL	1
2	PORCH - COVERED	1

Yard Improvements

Year Built	Structure Type	Length or Sq. Ft.	# Units
------------	----------------	-------------------	---------



BUILDING PERMIT INSPECTION PROCEDURES

Please call 874-8703 or ~~874-8693~~ to schedule your inspections as agreed upon

Permits expire in 6 months, if the project is not started or ceases for 6 months.

The Owner or their designee is required to notify the inspections office for the following inspections and provide adequate notice. Notice must be called in 48-72 hours in advance in order to schedule an inspection:

By initialzing at each inspection time, you are agreeing that you understand the inspection procedure and additional fees from a "Stop Work Order" and "Stop Work Order Release" will be incurred if the procedure is not followed as stated below.

JB Pre-construction Meeting: Must be scheduled with your inspection team upon receipt of this permit. Jay Reynolds, Development/Review Coordinator at 874-8632 must also be contacted at this time, before any site work begins on any project other than single family additions or alterations.

NA Footing/Building Location Inspection: Prior to pouring concrete

NA Re-Bar Schedule Inspection: Prior to pouring concrete

NA Foundation Inspection: Prior to placing ANY backfill

NA Framing/Rough Plumbing/Electrical: Prior to any insulating or drywalling

✓ Final/Certificate of Occupancy: Prior to any occupancy of the structure or use. NOTE: ~~There is a \$75.00 fee per inspection at this point.~~

Certificate of Occupancy is not required for certain projects. Your inspector can advise you if your project requires a Certificate of Occupancy. All projects DO require a final inspection

✓ If any of the inspections do not occur, the project cannot go on to the next phase, REGARDLESS OF THE NOTICE OR CIRCUMSTANCES.

NA **CERTIFICATE OF OCCUPANCIES MUST BE ISSUED AND PAID FOR, BEFORE THE SPACE MAY BE OCCUPIED**

Paul A. Sieg
Signature of applicant/designee

Date

James Bond
Signature of Inspections Official

Date

CBL: 053C-034

Building Permit #: 03-0763