

DISPLAY THIS CARD ON PRINCIPAL FRONTAGE OF WORK



# CITY OF PORTLAND BUILDING PERMIT



**This is to certify that**

S S & M LLC /Protection Professionals

**Located at**

264 STATE ST

**PERMIT ID:** 2013-00053

**CBL:** 048 D023001

has permission to **install supervised fire alarm system.**

provided that the person or persons, firm or corporation accepting this permit shall comply with all of the provisions of the Statutes of Maine and of the Ordinances of the City of Portland regulating the construction, maintenance and use of the buildings and structures, and of the application on file in the department.

Notification of inspection and written permission procured before this building or part thereof is lathed or otherwise closed-in. 48 HOUR NOTICE IS REQUIRED.

A final inspection must be completed by owner before this building or part thereof is occupied. If a certificate of occupancy is required, it must be procured prior to occupancy.

  
Fire Prevention Officer

58

Code Enforcement Officer / Plan Reviewer

**THIS CARD MUST BE POSTED ON THE STREET SIDE OF THE PROPERTY  
THERE IS A PENALTY FOR REMOVING THIS CARD**

**BUILDING PERMIT INSPECTION PROCEDURES**  
Please call 874-8703 (ONLY)  
or email: [buildinginspections@portlandmaine.gov](mailto:buildinginspections@portlandmaine.gov)

With the issuance of this permit, the owner, builder or their designee is required to provide adequate notice to the city of Portland Inspections Services for the following inspections. Appointments must be requested 48 to 72 hours in advance of the required inspection. The inspection date will need to be confirmed by this office.

- **Please read the conditions of approval that is attached to this permit!! Contact this office if you have any questions.**
- **Permits expire in 6 months. If the project is not started or ceases for 6 months.**
- **If the inspection requirements are not followed as stated below additional fees may be incurred due to the issuance of a "Stop Work Order" and subsequent release to continue.**

**REQUIRED INSPECTIONS:**

Final - Fire

Final - Electric

The project cannot move to the next phase prior to the required inspection and approval to continue, REGARDLESS OF THE NOTICE OF CIRCUMSTANCES.

IF THE PERMIT REQUIRES A CERTIFICATE OF OCCUPANCY, IT MUST BE PAID FOR AND ISSUED TO THE OWNER OR DESIGNEE BEFORE THE SPACE MAY BE OCCUPIED.

**City of Portland, Maine - Building or Use Permit**

389 Congress Street, 04101 Tel: (207) 874-8703, Fax: (207) 874-8716

<b>Permit No:</b> 2013-00053	<b>Date Applied For:</b> 01/09/2013	<b>CBL:</b> 048 D023001
---------------------------------	--	----------------------------

<b>Location of Construction:</b> 264 STATE ST	<b>Owner Name:</b> S S & M LLC	<b>Owner Address:</b> 88 ANNAFRAN ST	<b>Phone:</b>
<b>Business Name:</b>	<b>Contractor Name:</b> Protection Professionals	<b>Contractor Address:</b> 325 US Rt 1 Falmouth	<b>Phone</b> (207) 775-5755
<b>Lessee/Buyer's Name</b>	<b>Phone:</b>	<b>Permit Type:</b> Fire Alarm System	

<b>Proposed Use:</b> Same: 13 Residential Dwelling units	<b>Proposed Project Description:</b> Install Fire Alarm
---	--

**Dept:** Zoning      **Status:** Approved w/Conditions      **Reviewer:** Marge Schmuckal      **Approval Date:** 01/09/2013  
**Note:** **Ok to Issue:**

1) ANY exterior work requires a separate review and approval thru Historic Preservation. This property is located within an Historic District.

**Dept:** Fire      **Status:** Approved w/Conditions      **Reviewer:** Ben Wallace Jr      **Approval Date:** 01/29/2013  
**Note:** **Ok to Issue:**

- 1) A 4100 series Knox Box is required.
- 2) Fire protection systems shall be maintained. If system is to be off line over 4 hours a fire watch shall be in place. Dispatch notification required 874-8576.
- 3) A master box connection is not authorized for this building.
- 4) Supervising Station monitoring for addressable fire alarm systems shall be by point.
- 5) All smoke detectors shall be photoelectric.
- 6) System CO detectors shall be located on the ceiling in the same room as permanently installed fuel-burning appliances and centrally located on every habitable level and in every HVAC zone of the building per NFPA 720:5.5.5.3.1. System CO detectors shall activate an audible alarm at the detector and FACP, and send an alarm signal the remote station. It shall not trip a/the master box.
- 7) Through-penetrations and membrane penetrations in fire walls, fire barrier walls, and fire resistance rated horizontal assemblies shall be protected by firestop systems or devices in conformance with NFPA 101:8.3.5 (ASTM E 814 or ANSI/UL 1479). Providing firestop labels at each firestop system or device and an onsite manual containing the detail for each firestop system or device used for the project will streamline final inspection approvals.
- 8) All fire alarm records required by NFPA 72 should be stored in an approved cabinet located at the FACP labeled "FIRE ALARM RECORDS".
- 9) The FACP shall not be located behind the entry door when it is in the open position.
- 10) In field installation shall be installed per code as conditions dictate.
- 11) The fire alarm system shall have a new fire alarm inspection sticker.
- 12) The installation shall comply with the following:  
 City of Portland Chapter 10, Fire Prevention and Protection;  
 NFPA 1, Fire Code (2009 edition), as amended by City Code;  
 NFPA 101, Life Safety Code (2009 edition), as amended by City Code;  
 City of Portland Fire Department Rules and Regulations;  
 NFPA 72, National Fire Alarm and Signaling Code (2010 edition), as amended by Fire Department Rules and Regulations; and  
 NFPA 70, National Electrical Code (2011 edition) as amended by the State of Maine
- 13) System acceptance and commissioning must be coordinated with alarm and suppression system contractors and the Fire Department. Call 874-8703 to schedule.
- 14) Records cabinet, FACP, annunciator(s), and pull stations shall be keyed alike.

<b>Location of Construction:</b> 264 STATE ST	<b>Owner Name:</b> S S & M LLC	<b>Owner Address:</b> 88 ANNAFRAN ST	<b>Phone:</b>
<b>Business Name:</b>	<b>Contractor Name:</b> Protection Professionals	<b>Contractor Address:</b> 325 US Rt 1 Falmouth	<b>Phone</b> (207) 775-5755
<b>Lessee/Buyer's Name</b>	<b>Phone:</b>	<b>Permit Type:</b> Fire Alarm System	

15 Audible signal shall be verified by the fire alarm company in the dwelling units with the doors closed per NFPA 72.

**City of Portland, Maine - Building or Use Permit Application**

389 Congress Street, 04101 Tel: (207) 874-8703, Fax: (207) 874-8716

Permit No: 2013-00053	Issue Date:	CBL: 048 D023001
--------------------------	-------------	---------------------

<b>Location of Construction:</b> 264 STATE ST	<b>Owner Name:</b> S S & M LLC	<b>Owner Address:</b> 88 ANNAFRAN ST ROSLINDALE , MA 02131		<b>Phone:</b>
<b>Business Name:</b>	<b>Contractor Name:</b> Protection Professionals	<b>Contractor Address:</b> 325 US Rt 1 Falmouth ME 04105		<b>Phone</b> (207) 775-5755
<b>Lessee/Buyer's Name</b>	<b>Phone:</b>	<b>Permit Type:</b> Fire Alarm System		<b>Zone:</b> R6
<b>Past Use:</b> 13 Residential Dwelling units	<b>Proposed Use:</b> Same: 13 Residential Dwelling units	<b>Permit Fee:</b> \$100.00	<b>Cost of Work:</b> \$8,000.00	<b>CEO District:</b> 4
<b>Proposed Project Description:</b> Install Fire Alarm		<b>FIRE DEPT:</b> <input checked="" type="checkbox"/> Approved <input type="checkbox"/> Denied <input type="checkbox"/> N/A  1/29/13		<b>INSPECTION:</b> Use Group: Type:
		Signature: <i>[Signature]</i> <i>(50)</i>		Signature:
<b>PEDESTRIAN ACTIVITIES DISTRICT (P.A.D.)</b>				
Action: <input type="checkbox"/> Approved <input type="checkbox"/> Approved w/Conditions <input type="checkbox"/> Denied				
Signature: Date:				

<b>Permit Taken By:</b> bjs	<b>Date Applied For:</b> 01/09/2013	<b>Zoning Approval</b>		
--------------------------------	--	------------------------	--	--

<ol style="list-style-type: none"> <li>This permit application does not preclude the Applicant(s) from meeting applicable State and Federal Rules.</li> <li>Building permits do not include plumbing, septic or electrical work.</li> <li>Building permits are void if work is not started within six (6) months of the date of issuance. False information may invalidate a building permit and stop all work..</li> </ol>	<b>Special Zone or Reviews</b> <input type="checkbox"/> Shoreland <input type="checkbox"/> Wetland <input type="checkbox"/> Flood Zone <input type="checkbox"/> Subdivision <input type="checkbox"/> Site Plan  Maj <input type="checkbox"/> Minor <input type="checkbox"/> MM <input type="checkbox"/> <i>ok with conditions</i> Date: <i>1/9/13</i>	<b>Zoning Appeal</b> <input type="checkbox"/> Variance <input type="checkbox"/> Miscellaneous <input type="checkbox"/> Conditional Use <input type="checkbox"/> Interpretation <input type="checkbox"/> Approved <input type="checkbox"/> Denied  Date:	<b>Historic Preservation</b> <i>within</i> <input type="checkbox"/> Not in District or Landmark <input type="checkbox"/> Does Not Require Review <input type="checkbox"/> Requires Review <input type="checkbox"/> Approved <input type="checkbox"/> Approved w/Conditions <input type="checkbox"/> Denied <i>Any exterior work requires A separate review &amp; approval</i> Date:
---	--	---	--

**CERTIFICATION**

I hereby certify that I am the owner of record of the named property, or that the proposed work is authorized by the owner of record and that I have been authorized by the owner to make this application as his authorized agent and I agree to conform to all applicable laws of this jurisdiction. In addition, if a permit for work described in the application is issued, I certify that the code official's authorized representative shall have the authority to enter all areas covered by such permit at any reasonable hour to enforce the provision of the code(s) applicable to such permit.

SIGNATURE OF APPLICANT	ADDRESS	DATE	PHONE
RESPONSIBLE PERSON IN CHARGE OF WORK, TITLE	DATE	PHONE	



# Fire Alarm Permit

If you or the property owner owes real estate or property taxes or user charges on any property within the city, payment arrangements must be made before permits of any kind are accepted.

Installation address: 264 State Street CBL: \_\_\_\_\_

Exact location: (within structure) Same

Type of occupancy(s) (NFPA & ICC): Apartment, 13 units

Building owner: SS & M, LLC (Michael Scannell & Miriam Scannell)

System Designer (point of contact): Must be Rich Brobst, Jr

Designer phone: 775-5755 / 899-7761 E-mail: rich@protectionprofessionals.net

Installing contractor: Campbell Electric Certificate of Fitness No: M1001

Contractor phone: 252-2411 E-mail: \_\_\_\_\_

This is a new application: YES  NO  New AES Master Box: YES  NO   
(Include Master Box approval form)

Amendment to an existing permit: YES  NO  Permit no: \_\_\_\_\_

**The following documents shall be provided with this application:**

- |  |   |
|--|---|
| <input checked="" type="checkbox"/> Floor plans                                | <input checked="" type="checkbox"/> Scope of Work               |
| <input checked="" type="checkbox"/> Wiring diagram                             | <input checked="" type="checkbox"/> 11 1/2 x 17s                |
| <input checked="" type="checkbox"/> Annunciator details                        | <input checked="" type="checkbox"/> pdf copy (may be e-mailed)  |
| <input checked="" type="checkbox"/> Input/ Output Matrix                       | <input checked="" type="checkbox"/> Designer qualifications     |
| <input checked="" type="checkbox"/> Equipment data sheets                      | <input checked="" type="checkbox"/> Battery/ voltage drop calcs |
| <input checked="" type="checkbox"/> Electrical Permit Pulled (check alarm/com) |   |

Master box approval only: YES  NO   
(If yes check *New AES Master Box* above)

COST OF WORK: 8000.00

PERMIT FEE: 100.00  
(\$10 PER \$1,000 + \$30 FOR THE FIRST \$1,000)

RECEIVED  
JAN 09 2013  
Dept. of Building Inspections  
City of Portland Maine

**The designer shall be the responsible party for this application.** Download a new copy of this application at [www.portlandmaine.gov/fire](http://www.portlandmaine.gov/fire) for every submittal. Submit all plans in electronic PDF in addition to readable 11 1/2 x 17s to the Building Inspections Department, 389 Congress Street, Room 315, Portland, Maine 04101.

Prior to acceptance of any fire alarm system, a complete commissioning and acceptance test must be coordinated with all fire system contractors and the Fire Department, and proper documentation of such test(s) provided.

All installation(s) must comply with the *City of Portland Technical Standard for Signaling Systems for the Protection of Life and Property*, available at [www.portlandmaine.gov/fire](http://www.portlandmaine.gov/fire).

Applicant signature: [Signature] Date: 1/3/2013

# Protection Professionals

325 US Route 1  
 Falmouth, ME 04105  
 Ph 207-775-5755  
 Fax 207-781-2064

# Device List

No. 4757

List Date
12/14/2012

<b>Bill To Name / Address</b>
Campbell's Electric, Inc. Attn: Accounts Payable P.O. Box 1834 Portland, ME 04104

<b>Job Site</b>
264 State Street Portland, Maine 04102

**CHANGING THIS DEVICE LIST DOES NOT ALTER THE ORIGINAL ESTIMATE**  
**Attach copy to Purchase Order for accounting**

Estimate No.

Item	Description	Qty To Order	Qty Ordered
FC901-U3	Cerberus-Pro fire alarm panel, 50 points	1	
FH901-R3	S54433-B103-A4; 50 Point system red enclosure	1	
Bat 12-12	Battery 12 VOLTS 12 AMP/HOURS SLA-1105	2	
IM-RJ31XSET	IM-RJ31XSET	2	
IK-1007	M101 lock set key, multiple cams	2	
DK-DTK120HW	DITEK AC SURGE PROTECTION	1	
06-SSU00672	Fire Document box 12 inches wide X 13.1 inches high X 2.25 inches deep, CAT 30 keyed	1	
SF-6580	Heater strip for panel	3	
AD-TG7GFS04	Fire Alarm Communicator, Cell based, 3G		
Bat 12-7	12V 7AH Batteries	1	
D8004	UL TRANSFORMER KIT	1	
500-648507FA	MANUAL PULL STATION DUAL ACTION KEY RESET CAST METAL	7	
500-034000FA	8701 Mini-Module for Contact Devices	7	
OH921	S54320-F6-A2 Smoke detector with single optical and heat detection	8	
FDCIO422	4 Input monitor module (sprinkler)	1	
500-636161	ZH-MC-R Horn/strobe, red, wall mount, Hi or Lo volume, 15cd, 30cd, 75cd, or 110cd (stockroom and fire panel room)	6	
500-636159	Horn, red, wall, double gang	13	
3261	Knox Box 3261 Hinged Door Black State of Maine Sales Tax	1	

Ordered By: \_\_\_\_\_

Date: \_\_\_\_\_

Received By: \_\_\_\_\_

Date: \_\_\_\_\_

# Cerberus™ PRO Fire Safety System

## 50-Point Addressable Fire Alarm Control Panel

Model FC901

### ARCHITECT AND ENGINEER SPECIFICATIONS

- An addressable fire alarm control panel (FACP) comprised of the following three (3) system components:
  - Main board (Model FCM901-U3)
  - 170-Watt power supply (Model FP2011-U1)
  - System enclosure (Model FH901-U3 / R3)
- System features:
  - Supports 50 addressable devices on one (1) 'Class A', or one (1) – two (2) 'Class B' circuits
  - Includes one (1) 'Class A', or two (2) 'Class B' notification appliance circuits (NACs)
  - Built-in digital alarm communication transmitter (DACT)
  - Built-in RS-485 connection for remote annunciators
  - Resettable and non-resettable 24VDC auxiliary power
  - Optional connectivity to a leased-line / city-tie module
  - Off-normal warning message prior to reset
  - Fast and easy set-up with custom-configuration tool



- Alphanumeric keypad
  - for manual configuration
- ©UL 864 9<sup>th</sup> Edition Listed;  
FM, CSFM & NYC Fire Department Pending

### Product Overview

Model FC901 is an addressable FACP that provides a cost-effective solution for simple fire-alarm system applications.

Small and compact in design, Model FC901 is ideal for small fire-protection applications using less than 50 addressable devices:

- retail outlets / strip malls
- doctor's offices
- dry cleaners
- restaurants
- banks, etc.

With its built-in DACT and two (2) NACs, Model FC901 is powerful enough to economically meet the needs of these applications.

### Specifications

The Model FC901 FACP consists of a main board (Model FCM901-U3); a 170-Watt power supply (Model FP2011-U1), and a Model FH901-U3 / R3 system enclosure.

### Main Board

The Model FCM901-U3 / R3 main board provides system display and control, as well as connections for system field wiring, via removable terminal blocks.

The 3.5-inch (8.9 centimeters) by 1.5" (3.8 centimeters) LCD display shows all system messages and event status. Each event may have a custom message up to 28 characters that describes the event's location.

The backlit LCD screen illuminates on any system event, or manual key press. New, 'unacknowledged' events are indicated by a flashing exclamation point ('!'). Once 'acknowledged,' the exclamation point changes to a check mark ('✓'). A system-status line shows the quantity of events presently active.

The main board supports system-status LEDs, based upon the following conditions of Model FC901:

- Power
- Alarm
- Trouble
- Supervisory
- Ground-Fault

Cerberus PRO 50-Point Control Panel **9813**



## Specifications – (continued)

There are also LEDs to indicate when audible circuits are 'active' or 'silenced.' The main board supports four (4) system-control buttons, including: *Acknowledge; Alarm Silence; Unsilence, and Reset.*

The system offers an off-normal warning feature, alerting users when active devices are not ready for reset. These active devices may include manual stations that have not been reset; smoke detectors with smoke remaining in the optical chamber, etc.

Additionally, the main board supports an alphanumeric keypad, as well as navigation keys, which are used for scrolling maintenance functions and system configuration.

The main board supports connection for up to 50 addressable devices, via one (1) 'Class A', or one (1) to two (2) 'Class B' circuits. The loop supports all FDnet devices, including the Cerberus PRO Fire Safety and Model 'H'-series devices. The main board also supports one (1) 'Class A' or two (2) 'Class B' NACs.

Each NAC supports a maximum 2.5 Amps – with 2.5 Amps, max., allowed between both NACs. Each NAC can be set to a synchronized strobe, for horn-strobe devices, or for audible devices. Audible devices can be set for:

- 'STEADY'
- 'ANSI Temporal 3'
- 'March Time 30 / 60 / 120 Codes'

The main board supports four (4) 'Form C' relays for *Alarm, Trouble, Supervisory* and user-programmable events. Each relay is rated at 2 Amps at 30VDC maximum, resistive. The main board supports two (2) auxiliary 24VDC connections. Upon system reset, one (1) connection interrupts the power for :05 seconds for use with (4) four-wire conventional detectors. Each auxiliary-power output is 24VDC, nominal – rated at 0.75 Amps.

The main board contains a built-in DACT (Model FCA2015-A1), which provides communication between Model FC901 and with the central or remote monitoring station. The built-in DACT supports two (2) separate programmable accounts, as well as two (2) connections to the public-switched telephone network. The connections support RJ31X male connectors.

The main board contains a battery-charging circuit, providing connection to lead-acid batteries rated at 24VDC, nominal. The main board can charge up to 18 AH batteries.

The main board contains a universal serial bus (USB) connector that supports connection for system configuration and module firmware upload, via the custom-configuration tool.

**SIEMENS Industry, Inc.**  
Building Technologies Division

Model FC901 can be configured using the configuration tool or manually from the alphanumeric keypad on the main board. An auto-configuration feature creates a basic system configuration of all connected devices to accelerate initial system commissioning.

### 170-Watt Power Supply

The Model FCM901-U3 main board also supports connection to the system power supply. The 170-Watt power supply (Model FP2011-U1) incorporates a 4.0A, non-resettable slow-blow fuse on the primary input, and includes a built-in AC-line filter for surge and noise suppression. Model FP2011-U1 mounts in a standard Siemens – Fire Safety enclosure, and there are no serviceable Siemens – Fire Safety parts to be maintained.

### 50-Point System Enclosure

The Model FH901-U3 / R3 enclosure for the Model FC901 FACP is available in either black or red, and supports all system modules. The enclosure also supports 12AH batteries.

**Note:** For systems requiring larger than 12AH batteries, use a  UL Listed battery box.

The Model FH901-U3 / R3 enclosure for the 50-point panel is comprised of a dual-mounting setup that allows the main board to be partially mounted in a lower-to-upper position. When temporarily installed in the lower position, technicians are allowed more space to install field wiring at the time of system set-up. When field-wiring installation is complete, the main board shall be moved to the upper position for standard mounting prior to applying power to the system.

Additionally, the enclosure supports an optional battery bracket (Model FHA901-U1) that can be used to secure batteries up to 12AH. Model FHA901-U1 is required to comply with seismic certification, pursuant to ASC / SEI 7-05, Section 13.2.2.

A flush-mount trim kit (Model FHA902-U1 / R1) is also available for use when flush mounting Model FH901-U3 / R3.

### Optional Accessories

The Model FC901 FACP has the capability of operating an optional leased-line, city-tie module (Model FCI2020-U1) that provides a local-energy output for municipal call-box connection. The leased-line, city-tie module is installed on the back of the main board of the Model FC901 FACP, and all field wiring is connected to the main board.

## Specifications – (continued)

Model FC901 contains a built-in RS-485 connection on the main board, thus eliminating the need for an additional communication module. The fire-system displays (FSD901-U3 / R3) are remote LED / LCD units that show the existing status of the Model FC901 FACP.

The Model FSD901-U3 / R3 optional display supports the following LEDs for system-status conditions:

- Power
- Alarm
- Trouble
- Supervisory
- Ground-Fault

There are also LEDs to indicate when audible circuits are 'active' or 'silenced.' The main board supports four (4) system-control buttons, including: *Acknowledge; Alarm Silence; Unsilence, and Reset.*

For Model FSD901-U3 / R3, a LED will illuminate for any given *Alarm, Supervisory and Trouble* Cerberus PRO-system event. A 3.5-inch (8.9 centimeters) by 1.5" (3.8 centimeters) LCD screen will give details of the event in alphanumeric form. The display screen can be scrolled to reveal additional events. Optional remote-system-control capabilities are also available.

The dimensions (based upon connection to a one-height-unit enclosure) for Model FC901 are as follows:

Approximate size: 16.25" (41.3 cm.) [H];  
18" (46 cm.) [W];  
5" (41.3 cm.) [D]

The weight (without operating unit or batteries) is approximately 9 Lbs [4082 g].

## Temperature and Humidity Range

Model FC901 is UL 864 9<sup>th</sup> Edition Listed for indoor dry locations within a temperature range of 120+/-3°F (49+/-2°C) to 32+/-3°F (0+/-2°C) and a relative humidity of 93+/-2% at a temperature of 90+/-3°F (32+/-2°C).

## Related Documentation

Product	Data Sheet Number
Model FP2011-U1 Power Supply	9806
Leased-Line / City-Tie Module	9810

## Details for Ordering

Model Number	Part Number	Description
FCM901-U3	S54433-B101-A1	Cerberus PRO Main Board {for 50-point system}
FP2011-U1	S54400-Z59-A1	170-Watt Power Supply
FH901-U3	S54433-B103-A3	System Enclosure, Black {for 50-point system}
FH901-R3	S54433-B103-A4	System Enclosure, Red {for 50-point system}

### Optional Accessories

Model Number	Part Number	Description
FHA901-U1	S54433-B107-A1	Battery Bracket
FHA902-U1	S54433-B103-A3	Flush-Mount Trim Kit, Black
FHA902-R1	S54433-B103-A4	Flush-Mount Trim Kit, Red
FCI2020-U1	S54400-A57-A1	Leased-Line / City-Tie Module
FSD901-U3	S54433-C102-A1	System Display, Black {for 50-point system}
FSD901-R3	S54433-C102-A2	System Display, Red {for 50-point system}

**FC901 Battery Calculations Worksheet**

ver. 1.3

7-Feb-2012

Fixed Field	Enter Numbers Here
Calculated Field	Choose a value

**Ref. No**

**Submitted By**

---



---

FC901 Panel		Standby (A)	Alarm (A)
Main Board		0.178	0.203
Device Current Draw		0.0134	0.0134
NAC 1		0	3
NAC 2		0	
Aux power (external)			
FCACity Tie			
FSD901 Remote Annun.			

Devices	Qty			
HFP-11 / 8713				
HFPO-11 / 8710				
HFPT-11 / 8712				
OOHC941				
OOH941				
OH921				
OP921	8	0.0024	0.0024	
HI921				
FDCIO422	1	0.0012	0.0012	
HMS / 8700-S/D/M	7	0.0098	0.0098	
HTRI-S / 8702				
HTRI-D / 8703				
HTRI-R / 8704				
HZM / 8705				
HCP / 8706				
ILED / 8726				
<b>Total</b>	<b>16</b>	<b>0.0134</b>	<b>0.0134</b>	<b>System OK</b>

<b>Total Current</b>		<b>0.1914</b>	<b>3.2164</b>
----------------------	--	---------------	---------------

<b>Standby Time</b>	<b>24</b>	<b>4.594</b>
---------------------	-----------	--------------

<b>Alarm Time</b>	<b>5</b>	<b>0.268</b>
<b>AH required (no reserve)</b>		<b>4.862</b>
<b>Battery Reserve</b>	<b>120%</b>	

<b>AH Required (with reserve)</b>	<b>5.83396</b>	<b>System OK</b>
-----------------------------------	----------------	------------------

## Sequence of Operations

	Audio/visual activation	Activate audible/visual signal at FACP & Annunciator	Device Description at FACP & Annunciator	Shutdown of HVAC equipment	Log event in system history	Activate Elevator Fire Hat	Activate Elevator primary or secondary control	Activate Elevator shunt trip	Silence of audible devices Including FACP & annunciator	Release door holders	Release locked doors	Event acknowledgement	Reset of all system functions and all visual devices	Remote transmission to Central Station A=alarm; T=trouble; S=Supervisory; L = log only	Remote indicator
Manual Pull Stations	X	X	X		X					X	X			A	
Smoke detectors common area	X	X	X		X					X	X			A	
Smoke detectors elevator lobbies	X	X	X		X		X			X	X			A	
Smoke Detectors elevator shaft/machine room	X	X	X		X	X	X			X	X			A	
Duct mounted Smoke Detectors		X	X	X	X									S	X
Heat Detectors common area/inside apartments	X	X	X		X					X	X			A	
Heat Detectors Elevator shaft/machine room	X	X	X		X	X		X		X	X			A	
Sprinkler flow or pressure switches	X	X	X		X					X	X			A	
Sprinkler Tamper, low temp, or low air		X	X		X									S	
Secondary fire panel such as kitchen hood	X	X	X		X					X	X			A	
FACP/annunciator silence button		X	X		X			X						L	
FACP/annunciator acknowledge button		X	X		X							X			
FACP/annunciator reset button		X	X		X								X	L	
Removal of any device		X	X		X									T	
Ground fault		X	X		X									T	
System wiring "open"		X	X		X									T	
AC Power loss		X	X		X									T	
Secondary power loss		X	X		X									T	
Telephone line loss		X	X		X									T	



TELGUARD

# TG-7FS

## CELLULAR ALARM COMMUNICATOR

### COMMERCIAL FIRE

#### PRODUCT FEATURES

- ▶ Meets UL 864 requirements for sole, primary or backup path communications.
- ▶ Supports virtually all alarm formats for universal panel compatibility.
- ▶ Connects to your central station's PSTN or IP receivers.
- ▶ Saves your customers money by replacing landline costs.

The Telguard TG-7FS is the ideal cellular alarm communications solution for commercial fire systems. The TG-7FS transmits alarm signals from the fire panel over the digital cellular network to the designated monitoring station.

Compliant with the 2010 Edition of NFPA 72, the TG-7FS can serve as the sole communications path for the fire alarm system, replacing all of the landlines currently dedicated to the master control unit. On average, cellular monitoring costs the end user significantly less than a dedicated landline. For each landline replaced with a TG-7FS, the monthly communications bill decreases.

By being able to signal failures to the central station within five minutes of an outage, the TG-7FS can be installed as the sole path for commercial fire installations. For existing installations, all landlines can be swapped for a single TG-7FS because of the new five minute supervision mode.

The TG-7FS can also be installed as a backup path, and upgraded to sole path at a later date.

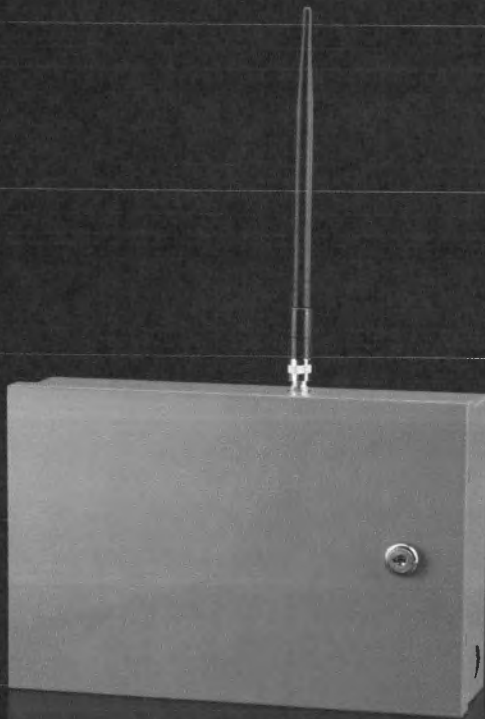

#### Telguard Online

Telguard makes adopting cellular easy with a secure Internet portal. The straightforward web interface allows security dealers and central stations to quickly and efficiently access Telguard based services 24/7. This advanced tool has multi-level user authorization and provides total account management of UL Listed Telguard cellular alarm communicators.

#### Telguard Cellular Service

Telguard Cellular Service provides nationwide digital cellular network coverage for all Telguard units. Telguard's Communication Center is UL listed and provides seamless connectivity between the alarm panel, the Telguard family of products and the central station. Telguard Technical Support provides a single point of contact for both cellular service and Telguard product questions.

#### Advanced Reliability

- Available relay output for tripping the alarm control panel when a trouble condition occurs.
- Automatic self-tests with central station notification ensure the cellular system is operating.
- 128 bit AES (Advanced Encryption Standard) alarm signals ensure authentication and security.
- Features SMS backup to reduce false alarms, providing supervision using SMS if GPRS fails.





**TELGUARD**

**TG-7FS**

CELLULAR ALARM  
COMMUNICATOR

**Power**

- Transmit power: 1.0W-2.0W (maximum allowable).
- Power Consumption: 60mA (Standby) 250mA (Transmission).
- Transformer: 12VAC, 800mA UL listed plug-in.

**Radio Transceiver**

- Dual band cellular and PCS.
- GSM 850MHz: Class 4 (2 watts).
- GSM 1900MHz: Class 1 (1 watt).
- Antenna: 9" dipole with 2dBi gain, 12 ft of cable and universal mounting bracket.
- FCC part 15, 22, 24 and 68 compliant.

**Physical Details**

- TG-7FS: 7.5" H x 11.5" W x 3.5" D
- Shipping Weight: 8lbs
- Operating Environment: 0°C to +50°C; up to 95% humidity (non-condensing).

**Standard Features**

- Full data reporting.
- Automatic self-test (5 min. & daily).
- Power supply with battery harness.
- Locking, red metal enclosure.
- Two programmable supervisory trip outputs.
- Alarm format support for SIA2, Contact ID, pulse (3x1, 4x2), modem IIe, & IIIa2, DMP.
- Telephone line monitor built-in, with Standard Line Security.

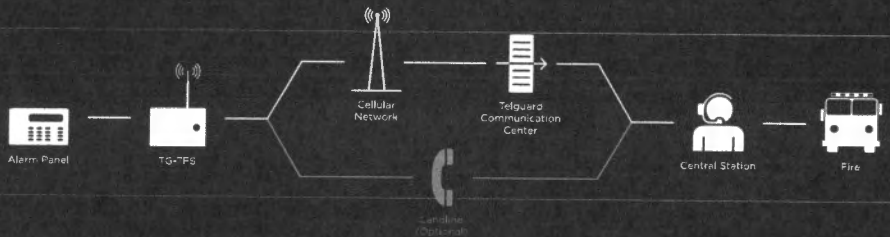

Telguard technology allows full data reporting for unlimited point-to-point signal details and maximum transmitting power for superior in-building penetration.

Telguard products are easy to install, economical, and UL Listed.

**Accessories**

- ACD 12, ACD 35, ACD 50, ACD 100: 12/35/50/100 feet of low loss, high performance cable.
- HGD-0: High gain directional antenna.
- EXD-0: External antenna.

**UL Listings**

**Commercial Fire**  
864 • Control units & accessories for fire alarm systems

**Commercial Burglary**  
365 • Police Station connected burglar alarm units and systems  
1610 • Central station burglar alarm units

**Residential**  
985 • Household fire warning systems  
1023 • Household burglar alarm systems



**NO  
EXCUSES!**



# FDB

## Fire Alarm Control Unit (FACU) Records & Document Box

The Space Age FDB has been developed to be a code compliant solution to a mandated item specified by the National Fire Code (NFPA 72).

An internal galvanized sleeve holds the documents safely and securely. Access to the documents is via a high security CAT 30 Lock Set.

The galvanized sleeve also contains 2 hooks for key rings or thumb drives, a place for several business cards, a cutout for a 1.4 Oz. can of test gas and a slot where a standard CD "jewel" case can be stored.

Held in by two "wing nuts" the sleeve is easily removable to allow storage of a 1.5" 3 ring binder.

The door reads "FACU MAINTENANCE RECORDS" in 1" tall white lettering. Custom Logo and Lock Sets are available upon request.

NFPA 72 section 6.2.2.1 states, "A record of installed software and firmware version numbers shall be maintained at the location of the fire alarm control unit." The FDB is large enough to hold Operating Manuals, Permits, Shut-Down Instructions and more.

### Standard Features:

- Overall Dimensions are:  
12" Wide x 13.1" High x 2.25" Deep
- CAT 30 Secured Locking Door
- Piano Hinged Door w/Notes Sticker
- Removable document holder can hold 1" of 8.5" x 11" paperwork
- Powder Coat Red Finish
- 16 Gauge CRS construction
- Embossed:
  - Key Ring Hooks
  - Business Card Holder
  - CD Case Slot
- 1.4 Oz. can of detector test gas
- Private labeling available

Key Ring  
Hooks

Canned  
Smoke

Business  
Card Holder

CD Jewel  
Case

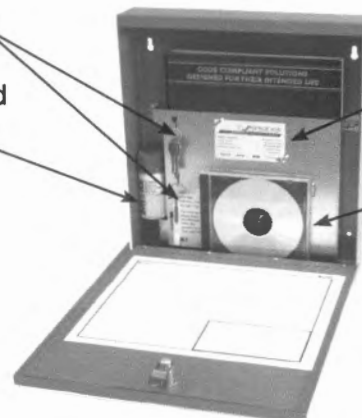

ISO 9001  
REGISTERED  
COMPANY



**AE-BOX**

Space Age Electronics, Inc.  
www.1sae.com  
800.486.1723 Toll Free  
508.485.0966 Local  
508.485.4740 Fax

**Specifications:**

The Fire Document Box (FDB) shall be constructed of 16 gauge cold rolled steel (CRS), it shall be painted with a durable red powder coat paint. The front door shall be lettered with the words "FACU MAINTENANCE RECORDS" in White indelible letters 1" in height. The door of the FDB shall be locked with a keyed lock (standard shall be CAT 30, but others shall be available along with Private Labeling).

Inside the cabinet shall contain a 16 gauge galvanized CRS sleeve. This sleeve shall allow for the storage of 1" of paper, test and inspection records, manuals and other important documents. The sleeve shall also facilitate the hanging of key rings and thumb drives (for data storage) along with business cards and space for a CD 'jewel' case. The unit shall also contain a 1.4oz can of smoke detector test gas. Inside the door shall have a "Notes" label for the recording of valuable information such as AHJ approvals, various system codes and the location of hard to find devices.

If so desired, the internal sleeve (held in by 2 wing nuts) may be removed and the space used to insert a 1.5" 3 ring binder.

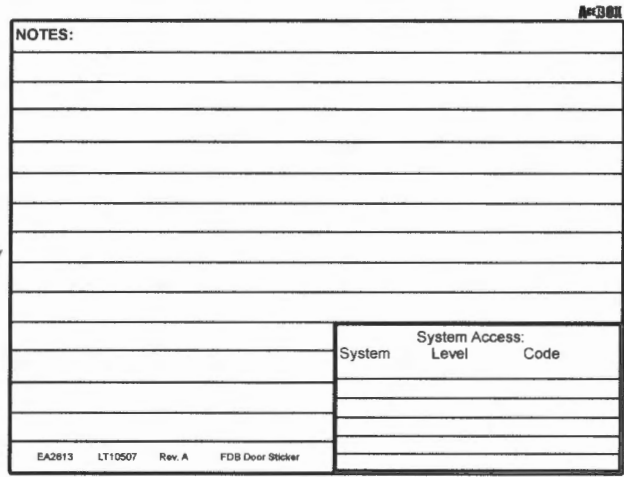
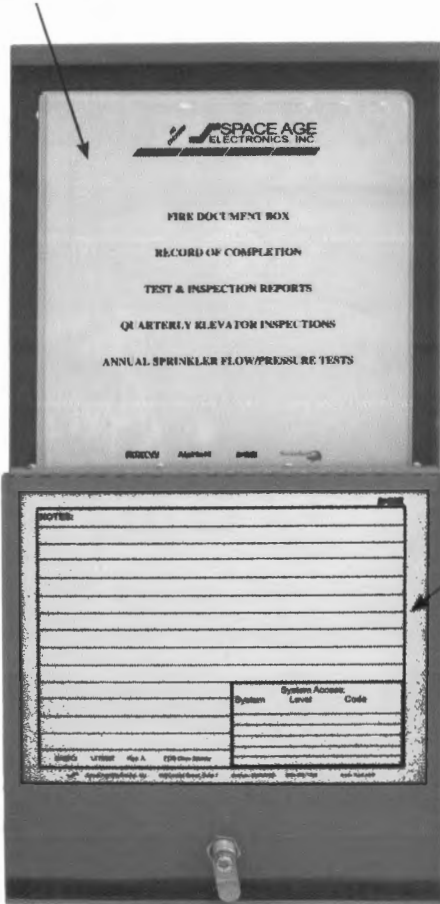

Notes Sticker inside FDB Door

**Ordering Information:**

Part # Description

- SSU00672 FDB Fire Document Box**
- SSU00673 FDB Custom Logo/lock**  
**(ask for Form FD10498 to order custom box)**
- CK1 Replacement 1.4 Oz Test Gas**

**APR BOX**  
Space Age Electronics, Inc.  
www.1sae.com  
800.486.1723 Toll Free  
508.485.0966 Local  
508.485.4740 Fax

*No Excuses, Just Solutions!*

This document is subject to change without notice, see doc # ED0479 for legal disclaimer



# STI HEATER KIT

## To Protect Costly Electronic Components in Frigid Areas

These easy to install kits are the answer for protecting expensive electronic units that must be installed in low temperature areas, indoors or outdoors. They operate with enclosed covers. In addition to assuring continued operation of protected units, they also keep LCD's from becoming sluggish and help them stay visible.

## Two Basic Systems Available

The 12-volt system (STI-6580) incorporates a 12-volt transformer and is rated at 25 watts. The 24-volt system (STI-6583) is designed to get its power directly from a remote power supply (other than the fire panel) or CCTV power source. It is rated at 8 watts. Both systems include a foil heater pad with adhesive backing and a thermostat.

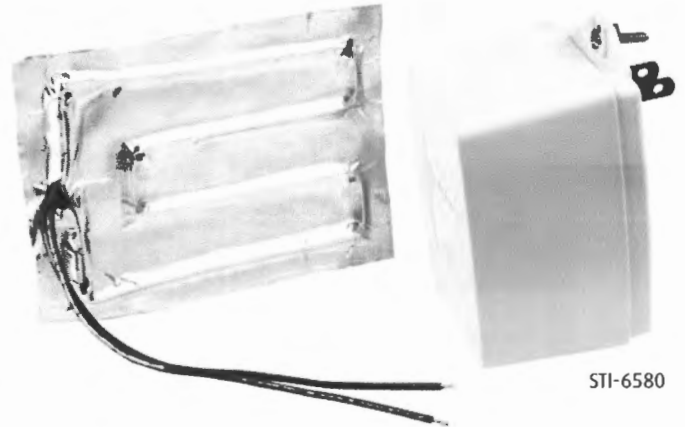

## Features

- Allows critical electronic components to operate at low temperatures.
- Self-adhesive heater pad.
- Keeps control panels warm when mounted in a protective cover or enclosed space. Results may vary based on installation and enclosure used.
- Temperature controlled.
- Thermostat active 23°F to 41°F (-5°C to 5°C).
- Both 12-volt and 24-volt models available.
- Can be mounted inside control panels to keep batteries and electronics operational.
- Keeps LCD's from becoming sluggish and helps them stay visible at freezing temperatures.
- Easy to install and highly effective.
- One (1) year warranty from the date of original purchase.



## Safety Technology International, Inc.

2306 Airport Road • Waterford, Michigan 48327-1209

Phone: 248-673-9898 • Fax: 248-673-1246 • Toll Free: 800-888-4784 • E-mail: [info@sti-usa.com](mailto:info@sti-usa.com) • Web: [www.sti-usa.com](http://www.sti-usa.com)

Europe Branch Office • Unit 49G Pipers Road • Park Farm Industrial Estate • Redditch • Worcestershire • B98 0HU • England

Tel: 44 (0) 1527 520 999 • Fax: 44 (0) 1527 501 999 • Freephone: 0800 085 1678 (UK only) • E-mail: [info@sti-europe.com](mailto:info@sti-europe.com) • Web: [www.sti-europe.com](http://www.sti-europe.com)

# STI HEATER KIT

## Dimensions and Technical Information

**Models Available**

**STI-6580** 12 volt heater Kit  
**STI-6583** 24 volt heater Kit

### SPECIFICATIONS

Heater Pad Size	4" x 5 1/2"
Thermostat Size	3/4" x 1/4" x 3/16"
Thermostat Active	23°F to 41°F (-5°C to 5°C) Creep action thermostat
STI-6580 power	12 Volt 25 Watts (2.25 amp) AC or DC 40 VA 12 VAC Power Supply Included
STI-6583 power	24 Volt 12 Watts (.5 amp) AC or DC Power Supply Not Included

**Note**

Keeps control panels warm when mounted in a protective cover or enclosed space. Results may vary based on installation and enclosure used.

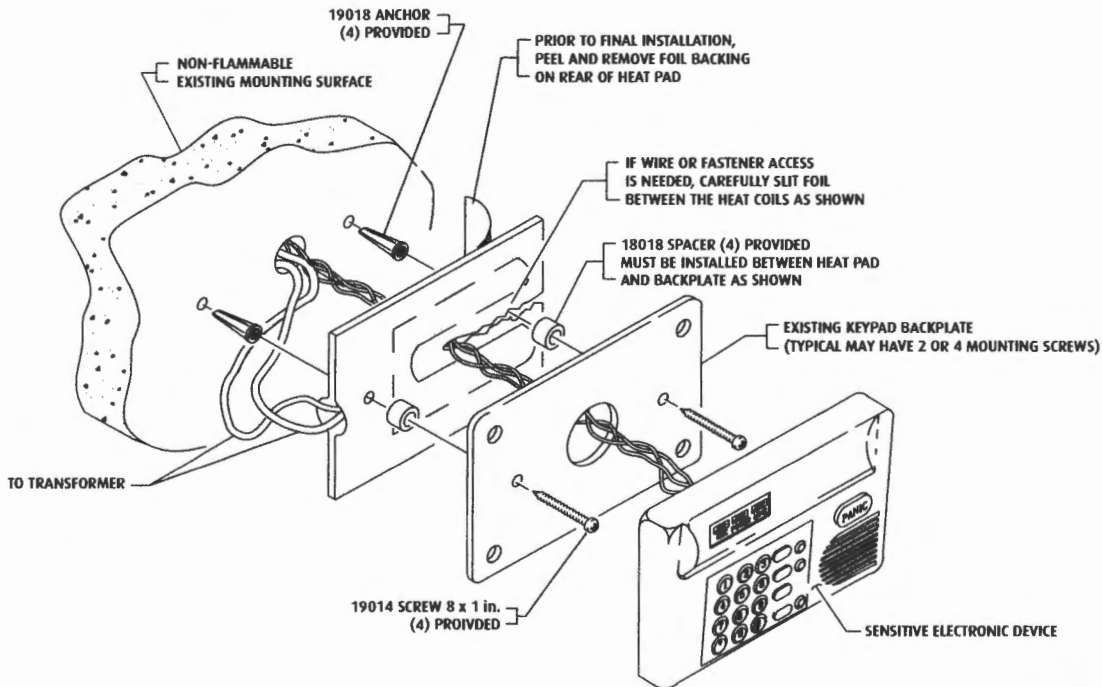
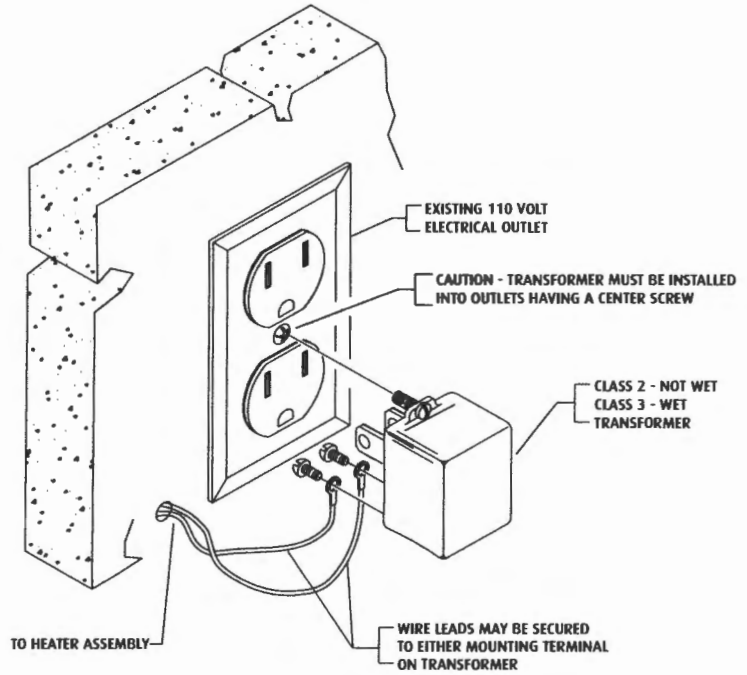

**Series PM6600 & PM6700 Manual Non-Code Keyed Stations****Features**

- MM101 Key Switch Cover
- Sturdy Metal Construction
- Enclosed Switch with Optional Glass Rod
- 10 Amp @ 120 Vac, 5 Amp @ 24 Vdc Switch Contact Rating
- Stations Available are: Single Action, Dual Action, Pre-Signal / General Alarm, Institutional, Weatherproof, and Explosion Proof
- UL, CSFM Listed & MEA approved
- Made in USA

**Description**

The PM6600/6700 series meets the requirements of the keyed reset station in every way. By using the standard Faraday MM101 series key, the user eliminates the need to search through many different reset keys. All stations are constructed of a solid die cast housing and come painted glossy red. The back switch plate is made of thick 14 Ga. plated steel and comes in a one gang size.

The electrical switch has a hefty 10 Amp @ 120 Vac normally open contact rating. All stations come with terminal block connections with the exception of the single action stations. These may be ordered with terminal blocks or pigtails (See ordering information for a more detailed description).

Explosion proof and weatherproof units come complete with their own back box. Optional PM6767 matching red surface interior back boxes are also available.

**Operation****Alarm**

To activate the manual station, a firm downward pull of the recessed pull lever is required. Such action locks the lever in the down position, breaks the glass rod, (if used) and actuates the switch creating an alarm condition.

**Reset**

To restore an operated manual station to normal standby condition requires the use of a standard Faraday MM101 key. The lock, located at the top of the station, is turned with an inserted MM101 key.

PM6608/  
PM6700 (right) &  
PM 6696 (below)



This lets the front of the station swing down and allows the recessed pull down lever to be reset in the normal up position. Replacement of the glass rod (if used) is not necessary to reset the station. However, spare glass rods can be stored inside the station. To lock the station swing the front of the station back up to its original position and turn the MM101 key in the previously operated position.

**Engineering Specification**

Furnish and install where located on the drawings Faraday non-code pull stations. The stations should be pull down operation type with operation instructions provided on the station in raised letters. The station should be of metal construction, finished in fire alarm red/white, and shall be capable of proper operation with or without a break glass rod. Stations using any plastic parts other than the switch body, or requiring the use of a break glass rod to maintain a standby condition shall not be acceptable.

Upon operation the pull down lever shall lock into the alarm position and remain so until manually reset. A common Faraday MM101 key shall be required to gain access for resetting the station, testing the station or replacing the glass rod. Stations with test features that do not test the actual station actuating switch shall not be acceptable.

Stations shall contain one or more normally open alarm contacts. Wiring to the fire alarm system initiating circuit shall be via pressure type screw terminals or pigtail wires with in and out wiring required.

## Specifications

### Electrical

Contacts – All contacts except General Alarm: 10A @ 120 Vac, General Alarm: 5A @ 30 Vdc

### Dimensions

4-3/4" (H) x 3-3/16" (W) x 7/8" (D)

### Weight

15-1/2 oz.

### Mounting

Single gang box

## Wiring

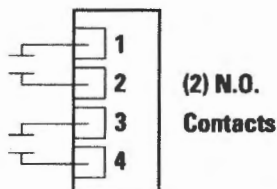
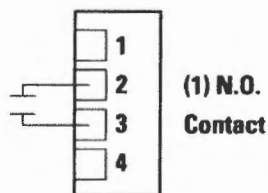

## Ordering Information

Model	Description	Part No.
<b>Single Action Stations</b>		
PM6700	(RMS-1P-KL) Station, N.O., Pigtails	500-648504FA
PM6608	(RMS-1T-KL) Station, N.O., Terminals	500-648505FA
<b>Dual Action Stations</b>		
PM6696	(RMS-2T-LP-KL) Station, (2) N.O., Terminals	500-648507FA
<b>Pre-Signal/General Alarm Stations</b>		
PM6695	(RMS-1T-KS-KL) N.O. Pre-sig, N.O. Terminals	500-648265FA
<b>Weatherproof Stations</b>		
PM6699	(RMS-2T-WP-KL) (2) N.O. Terminals	500-648266FA
<b>Accessories</b>		
PM6698	(BB) Surface Back Box, Interior	500-648506FA
PM7601	Glass Rods (pack of 10)	500-648245FA
10531	(STI1130) Cover, surface mount w/horn	500-648563FA
10538	(STI1130) Cover, flush mount, w/ horn	500-648591FA
10539	(STI1200) Cover, flush mount, w/o horn	500-648253FA



Siemens Building Technologies, Inc.  
8 Fernwood Road • Florham Park, NJ 07932  
Tel: (973) 593-2600 • Fax: (973) 593-6670  
Web: [www.faradayfirealarms.com](http://www.faradayfirealarms.com)

**WARNING** - The information contained in this document is intended only as a summary and is subject to change without notice. The devices described in this document have specific instruction sheets which cover various technical, limitation and liability information. Copies of these instruction sheets and the General Product Warning and Limitations Document, which also contains important information, are provided with the product and are available from the Manufacturer. Information contained in these documents should be consulted before specifying or using the product. For further information or assistance concerning particular problems contact the Manufacturer.

## Z Strobes, Horns, Horn/Strobes

### Features

- UL listed. ULC, CSFM, and FM pending.
- ADA/NFPA compliant
- EZ Mount design, with separate base plate, provides ability to pre-wire the base and test the circuit wiring before the walls are covered
- The base plate is protected by a disposable cover and the appliances can quickly snap onto the base after the walls are painted.
- EZ Mount Universal Mounting Plate (ZBB) – uses single plate for ceiling and wall mount installations
- Wall Mount models feature field selectable candela settings of 15/30/75/110cd and 135/185cd
- Ceiling Mount models feature field selectable candela settings of 15/30/75/95cd and 115/177cd
- Strobes can be synchronized using the Siemens 5406B sync modules, MPC-6000 panel, MPC-7000 panel, or RSE-300 power supply with built-in sync protocol
- "Special Applications" listed with Siemens panels
- Strobes produce 1 flash per second
- Selectable Continuous Horn or Temporal (Code-3) Tones with selectable 90 or 95 dBA setting (ZH model)

### Description

The Siemens Series Z notification appliances feature an easy snap on base that is designed to simplify the installation and testing of horns, strobes, and horn/strobes. The separate Series Z snap on base can be pre-wired so circuit wiring can be fully tested before the appliance is installed and before the walls are covered. Once all surrounding work is complete, the appliance can be simply installed by snapping it on the base. Shorting contacts in the base, which provide continuity for circuit testing, are permanently opened when the appliance is installed so any subsequent removal of the appliance will indicate a trouble condition on that circuit at the control panel when circuit supervision is enabled. The same base is used for all Series Z horns, strobes and horn/strobes to provide consistent installation and easy replacement of appliances if required. A locking screw is also included for the appliance to provide extra secure installation.

The Siemens Series Z appliances incorporate the same dependable circuitry and high efficiency optics that are used in Siemens ST strobes, NS horn/strobes and NH horns and have the same high performance ratings. The Series Z appliances are "Special Applications" listed with Siemens panels.



Series ZH

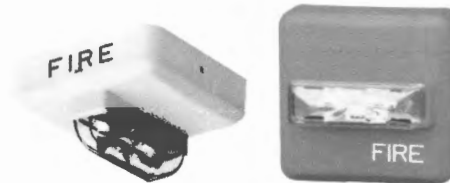

Series ZR

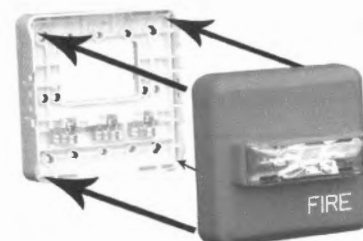

ZR AND ZH Mounting

### Engineering Specifications

#### General

Audible/visual notification appliances shall be listed for indoor use and shall meet the requirements of FCC Part 15 Class B. These appliances shall be listed under UL Standard 1971, (Standard for Safety Signaling Devices for Hearing Impaired) and UL Standard 464 (Fire Protective Signaling). The appliances shall use a universal backplate that shall allow mounting to a single-gang, double-gang, 4-inch square, 4" octal, or a 3-1/2" octal backbox. Two wire appliance wiring shall be capable of directly connecting to the mounting back plate. Continuity checking of the entire NAC circuit prior to attaching any audible/visual notification appliances shall be allowed. A dust cover shall fit and protect the mounting plate. The dust cover shall be easily removed when the appliance is installed over the backplate. Removal of an appliance shall result in a trouble condition by the Fire Alarm Control Panel (FACP).

#### Strobes

Strobe appliances shall produce a minimum flash rate of 60 flashes per minute (1 flash per second) over the Regulated Input Voltage Range and shall incorporate a

Xenon flashtube enclosed in a rugged Lexan® lens. The strobes shall be available with two or four field selectable settings in one unit and shall be rated, per UL 1971, for up to 185 cd for wall mounting and 177 cd for ceiling mounting. The strobes shall operate over an extended temperature range of 32°F to 120°F (0°C to 49°C) and be listed for maximum humidity of 95% RH. Strobe inputs shall be polarized for compatibility with standard reverse polarity supervision of circuit wiring by a Fire Alarm Control Panel (FACP).

#### Audibles and Audible/Strobe Combinations

Horns and horn/strobes shall be listed for Indoor use under UL Standard 464. The horns shall be able to produce a continuous output or a temporal code-3 output that can be synchronized. The horns shall have at least 2 sound level settings of 90 and 95 dBA.

#### Synchronization Modules

When synchronization of strobes or temporal Code-3 audibles is required, the appliances shall be synchronized using the Siemens 5406B sync modules, MPC-6000 panels, MPC-7000 panels, or RSE-300 power supplies with built-in sync protocol. The strobes shall not drift out of synchronization at any time during operation. Au-

dibles and strobes shall be able to be synchronized on a 2-wire circuit with the capability to silence the audible if required. If the sync module or power supply fails to operate (i.e., contacts remain closed), the strobes shall revert to a non-synchronized flash rate. All notification appliances shall be listed for "Special Applications".

- Strobes are designed to flash at 1 flash per second minimum over their "Regulated Input Voltage Range".
- All candela ratings represent minimum effective strobe intensity based on UL Standard 1971.
- Series ZH Strobe products are listed under UL Standards 1971 and 464 for indoor use with a temperature range of 32°F to 120°F (0°C to 49°C) and maximum humidity of 93% (± 2%).
- Series ZH horns are listed under UL Standard 464 for audible signal appliances (Indoor use only).

### Technical Information

For complete technical information, please consult the relevant installation sheets as well as the Siemens Compatibility Guide.

### Ordering Information / Mounting Requirements / Approvals

Model Number	Order Code	Mounting Options#	Agency Approvals			
			UL	ULC	CSFM	FM
ZH-MC-R	500-636161	B, D, E, F	X	#	#	#
ZH-MC-W	500-636162	B, D, E, F	X	#	#	#
ZH-HMC-R	500-636163	B, D, E, F	X	#	#	#
ZH-HMC-W	500-636164	B, D, E, F	X	#	#	#
ZH-R	500-636159	B, D, E, F	X	#	#	#
ZH-W	500-636160	B, D, E, F	X	#	#	#
ZH-MC-CR	500-636165	B, D, E, F	X	#	#	#
ZH-MC-CW	500-636166	B, D, E, F	X	#	#	#
ZH-HMC-CR	500-636167	B, D, E, F	X	#	#	#
ZH-HMC-CW	500-636168	B, D, E, F	X	#	#	#
ZR-MC-R	500-636169	B, D, E, F	X	#	#	#
ZR-MC-W	500-636170	B, D, E, F	X	#	#	#
ZR-HMC-R	500-636171	B, D, E, F	X	#	#	#
ZR-HMC-W	500-636172	B, D, E, F	X	#	#	#
ZR-MC-CW	500-636174	B, D, E, F	X	#	#	#
ZR-MC-CR	500-636173	B, D, E, F	X	#	#	#
ZR-HMC-CR	500-636175	B, D, E, F	X	#	#	#
ZRS-HMC-CW	500-636176	B, D, E, F	X	#	#	#
ZBB-R	500-636193	Accessory - Includes base, dust cover, mounting screws and installation sheet				
ZBB-W	500-636194	Accessory - Includes base, dust cover, mounting screws and installation sheet				

X = listed/approved    # = pending    \* = Refer to Data Sheet #9675 for mounting options.

**WARNING:** PLEASE READ THESE SPECIFICATIONS AND INSTALLATION INSTRUCTIONS CAREFULLY BEFORE USING, SPECIFYING OR APPLYING THIS PRODUCT. FAILURE TO COMPLY WITH ANY OF THESE INSTRUCTIONS, CAUTIONS AND WARNINGS COULD RESULT IN IMPROPER APPLICATION, INSTALLATION AND/OR OPERATION OF THESE PRODUCTS IN AN EMERGENCY SITUATION, WHICH COULD RESULT IN PROPERTY DAMAGE, AND SERIOUS INJURY OR DEATH TO YOU AND/OR OTHERS.



Siemens Building Technologies, Inc.  
 8 Fernwood Road • Florham Park, NJ 07932  
 Tel: (973) 593-2600 • Fax: (973) 593-6670  
 Web: [www.faradayfirealarms.com](http://www.faradayfirealarms.com)



# Intelligent Detection Devices

## Multi-Criteria Fire Detector Model OH921

### ARCHITECT AND ENGINEER SPECIFICATIONS

- Multi-criteria addressable fire detector that incorporates photoelectric and thermal sensors
- Utilizes advanced signal processing with proven detection algorithms
- Differentiates between deceptive phenomena and an actual fire (nuisance-alarm avoidance)
- Compatible with Model DPU (device programmer / loop tester)
- Responds to both flaming and smoldering-fire signatures
- Field selectable application profiles
- Superior EMI immunity
- Remote sensitivity-measurement capability
- Tri-color detector status LED with 360° viewing
- Each detector is self-testing:
  - complete diagnostics performed every 10 seconds
  - self monitored for sensitivity within ©UL Listed limits
- Polarity insensitive utilizing *SureWire™* technology
- Compatible with DB-11 series mounting bases
- Compatible with FireFinder™ XLS control panels (with Siemens Model 'H'-series devices on the same loop)
- Listed and approved as heat detector
  - Rate-of-Rise Detection: 15°F / min. (8.3°C / min), and fixed 135°F (57°C)



- RoHS compliant
- Automatic environment compensation
- ©UL Listed and ©ULC Pending; CSFM and NYC Fire Dept. Approved

### Product Overview

The Model OH921 photoelectric detector incorporates both optical and thermal sensors, and uses advanced software algorithms to combine the signals into a neural network to create an intelligent multi-criteria detector. The encompassing result is a detector that provides enhanced detection to a wide range of products of combustion, while offering superior rejection to nuisance-alarm sources.

Model OH921 utilizes advanced multi-criteria detection technology that allows the detector to distinguish non-threatening deceptive phenomena (i.e. – cigarette smoke) while optimizing detection for the area. Model OH921 uses state-of-the-art microprocessor circuitry with error check, detector self-diagnostics and supervision programs.

Model OH921 is compatible with the Siemens Fire Safety field-device programmer / test unit (Model DPU), which is a compact, portable, menu-driven accessory for electronically programming and testing detectors, easily and reliably.

Model DPU eliminates the need for cumbersome, unreliable mechanical programming methods, such as dials or switches, and reduces installation and service costs by electronically programming and testing the detector prior to installation.

Model OH921 is a plug-in, addressable, two-wire and multi-criteria detector (with both photoelectric and thermal inputs) that is compatible with FireFinder XLS control panels.

Multi-Criteria Fire Detector **9600**

## Product Overview – (continued)

Each detector consists of a dust-resistant photoelectric chamber; a solid state, non-mechanical thermal sensor, and microprocessor-based electronics with a low-profile plastic housing. Every Model OH921 fire detector is shipped with a protective dust cover:

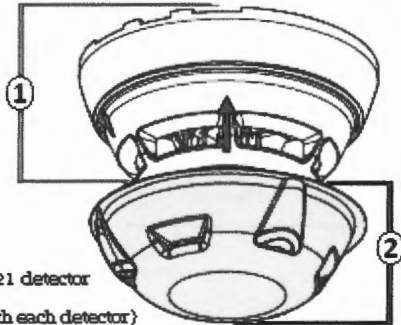

1) Model OH921 detector  
2) Dust cover  
(provided with each detector)

## Operation

Model OH921 utilizes an infrared light emitting diode (IRLED), and infrared light-sensing photodiode. Under normal conditions, light transmitted by the LED is directed away from the photodiode and scattered through the smoke chamber in a controlled pattern.

The smoke chamber is designed to manage light dissipation and extraneous reflections from dust particles or other non-smoke, airborne contaminants in such a way as to maintain stable, consistent detector operation. When smoke enters the detector chamber, light emitted from the IRLED is scattered by the smoke particles, and is received by the photodiode.

Model OH921 also utilizes a modern, accurate and shock-resistant thermistor to sense temperature changes.

The signal processing with detection algorithms allows the detector to first gather smoke and thermal data, and then analyze this information in the detector's 'neural network.' By comparing data received with the common characteristics of fires or fire signatures, Model OH921 can compare these signals to those of deceptive phenomena that cause other detectors to false alarm.

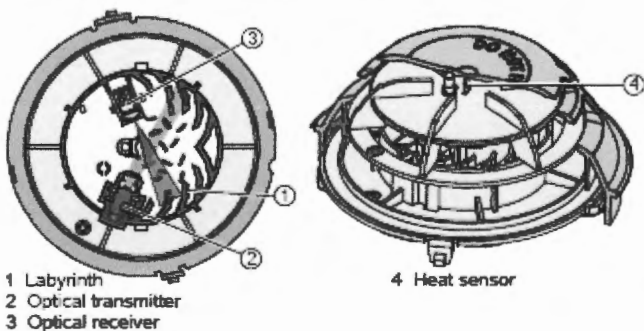

Each Model OH921 detector provides three (3) pre-programmed parameter sets that can be selected by the fire alarm control panel.

## Profile Overview

Model OH921 provides two (2) different alarm sources that can be selected individually (ON or OFF) by the control panel.

**Alarm Source 1 (Neural Network)** – Combines smoke – heat with the following selectable profiles:

- Sensitive
- Standard
- Robust

**Sensitive:** This parameter set is practically suitable for areas where few misleading sources of false alarm are present, and is appropriate where priority is given to detecting open fires as soon as possible (e.g. – typically a clean application with controlled environmental conditions.)

**Robust:** This parameter set offers improved resistance to false alarms in areas where misleading sources, such as cigarette smoke or exhaust fumes, may cause a nuisance alarm.

**Standard:** This parameter set is practically apt for normal office, hotel lobby type applications and is the default setting.

**Alarm source 2 (Thermistor)** – Heat only, provides the following:

- Static / fixed at 135°F (57°C), default setting
- Rate-of-Rise Detection: 15°F / min. (8.3°C / min)

If the detector is not programmed, Model OH921 will default to a 'standard' profile setting, which allows operation for a normal office-type environment.

Model OH921 contains a tri-color LED indicator, capable of flashing any one (1) of three (3) distinct colors: Green, Yellow, or Red. During each flash interval, the microprocessor-based detector monitors the following:

- Smoke in its sensing chamber
- Smoke sensitivity is within the range indicated on the nameplate label
- Internal sensors and electronics

Based on the results of the monitoring, the LED indicator flashes the following:

Flash Color	Condition	Flash Interval (in seconds)
<b>Green*:</b>	Normal supervisory operation. Smoke sensitivity is within rated limits.	10
<b>Yellow:</b>	Detector is in trouble and needs replacement.	4
<b>Red:</b>	Alarm condition.	1
<b>No Flash:</b>	Detector is not powered.	--

\* LED can be turned OFF.

Please follow the corresponding description of the panel used.



## Installation

All Model OH921 detectors use a surface-mounting base, Model DB-11 or Model DB-11E, which mounts on a 4-inch octagonal, square or single gang electrical box. The base utilizes screw-clamp contacts for electrical connections and self-wiping contacts for increased reliability.

The Model DB-11 base can be used with the optional Model LK-11 detector locking kit, which contains 50 detector locks and an installation tool to prevent unauthorized removal of the detector head. Model DB-11 has decorative plugs to cover the outer mounting screw holes.

Model OH921 may be installed on the same initiating circuit with the Siemens Model 'H'-series detectors (Models HFP-11 and HFPT-11); Model 'HMS'-series manual stations; Model 'HTRI'-series interfaces; Model HCP output-control devices, or Model 'HZM'-series of addressable, conventional zone modules for FireFinder XLS control panels.

All Model OH921 detectors are approved for operation within the  $\text{UL}$ -specified temperature range of 32 to 100°F (0 to 38°C).

## Model DPU

The Device Program / Test Unit accessory is used to program and verify the address of the detector. The technician selects the accessory's program mode, and enters the desired address. Model DPU automatically sets and verifies the address and tests the detector.

Model DPU operates on AC power or rechargeable batteries, providing flexibility and convenience in programmer and testing equipment from practically any location.

When in the test mode, Model DPU will perform a series of diagnostic tests without altering the address or other stored data, allowing technicians to determine if the detector is operating properly.

## Application Data

Installation of the Model OH921 series of fire detectors requires a two-wire circuit. In many retrofit cases, existing wiring may be used. 'T-tapping' is permitted only for Style 4 (Class B) wiring. Model OH921 is polarity insensitive, which can greatly reduce installation and debugging time.

Model OH921 fire detectors can be applied within the maximum 30-foot center spacing (900 sq. ft. areas,) as referenced in NFPA 72. This application guideline is based on ideal conditions, specifically, smooth ceiling surfaces, minimal air movement, and no physical obstructions between potential fire sources and the actual detector. Do not mount detectors in close proximity to ventilation or heating and air conditioning outlets. Exposed joints or beamed ceilings may also affect safe spacing limitations for detectors.

Should questions arise regarding detector placement, observe NFPA 72 guidelines. Good fire-protection system engineering and common sense dictate how and when fire detectors are installed and used. Contact your local Siemens Industry – Fire Safety distributor or sales office whenever you need assistance applying Model OH921 in unusual applications. Be sure to follow NFPA guidelines and  $\text{UL}$  Listed /  $\text{ULC}$  Pending installation instructions – included with every Siemens – Fire Safety detector – and local codes as for all fire protection equipment.

## Technical Data

### Operating

**Temperatures:** +32°F (0°C) to 100°F (38°C)

**Relative Humidity:** 0-95%; non-condensing

**Air Velocity:** 0–4,000 ft. / min (0-20m / sec)

**Air Pressure:** No effect

**Maximum Spacing:** 30-foot centers (900 sq. ft.), per NFPA 72 and  $\text{ULC}$ -S524 pending

**Input Voltage Range:** 16VDC – 30VDC

**Alarm Current:** 410uA

**Standby Current:** 250uA, max.  
(average)

**Detector Sensitivity Range:**  $\text{UL}$ : 1.10% to 2.62% / ft.  
 $\text{ULC}$ : 1.44 to 3.06% / ft.  
Pending

### Thermal Rating:

- Fixed-temperature set point: 135°F (57°C)
- Rate-of-Rise Detection: 15°F / min. (8.3°C / min)

**Detector Weight:** 0.317 lbs. (0.144 kg.)

### Mechanical Protection Guard:

$\text{UL}$  Listed /  $\text{ULC}$  Pending  
with STI Guard Model STI-9604

## Mounting Diagram Dimensions

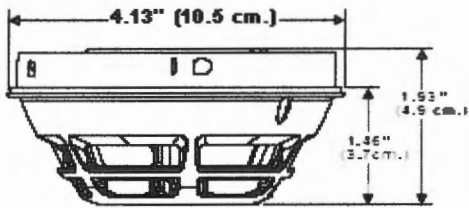

## Details for Ordering

Model Number	Part Number	Description
OH921	S54320-F6-A2	Addressable Multi-Criteria Fire Detector
DB-11	500-094151	Detector Mounting Base for Series 11
DB-11E	500-094151E	Detector Base {small}
RL-HC	500-033230	Remote Alarm Indicator: 4" octagon-box mount, red
RL-HW	500-033310	Remote Alarm Indicator: single-gang box mount, red
LK-11	500-695350	Base Locking Kit for Series 11 Detectors

### In Canada, order:

Model Number	Part Number	Description
DB-11C	500-095687	Detector Mounting Base for Series 11 Detectors (©ULC pending)

**Notice:** This marketing data sheet is not intended to be used for system design or installation purposes. For the most up-to-date information, refer to each product's installation instructions.

**SIEMENS Industry, Inc.**  
Building Technologies Division

Fire Safety  
8 Fernwood Road  
Florham Park, NJ 07932  
Tel: (973) 593-2600  
FAX: (908) 547-6877  
URL: [www.SBT.Siemens.com/FIS](http://www.SBT.Siemens.com/FIS)

(SII-FS)  
Printed in U.S.A.

Fire Safety  
2 Kenview Boulevard  
Brampton, Ontario  
L6T 5E4 / Canada  
Tel: (905) 799-9937  
FAX: (905) 799-9858

**August 2011**  
Supersedes sheet dated 7/11  
(Rev. 2)

## Intelligent Peripheral Devices Quad Interface Module (4-Input / 4-Output) Model FDCIO422

### ARCHITECT AND ENGINEER SPECIFICATIONS

- Four (4) inputs / four (4) outputs via one (1) address
- Status indication via LED display of all input / output functions
- Supports 'Class A' and 'Class B' wiring
- Input lines can be supervised for open, short and ground-fault conditions
- Light-emitting diode (LED) display of input / output status
- Polarity insensitive with *SureWire™* technology
- Microprocessor-controlled signal evaluation
- Two-wire installation
- Power supply via FDnet / C-Net module
- Communication via FDnet/C-NET
  - Individual addressing
- Mounts in one (1) electrical back box
  - Optional 4-inch and 5-inch square back boxes
- Four (4) relay outputs
  - Rated 2 – 8 Amps
- Electronic address programming is easy and dependable
- Easy front-end access to programming port and wiring terminals
- Model DPU programs and verifies address of the device, as well as performs test functionality
- Restriction of Hazardous Substances (RoHS compliant)
- ©UL 864 9<sup>th</sup> Edition Listed;  
FM, CSFM and NYC Fire Department Approved

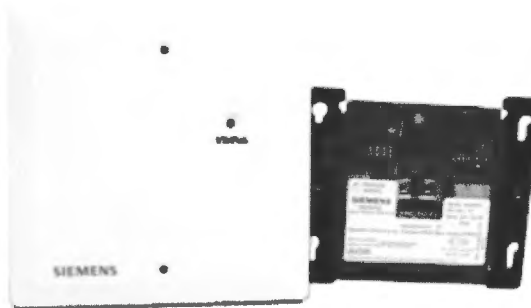

### Product Overview

The four (4) input / (4) output interface module (Model FDCIO422) from Siemens Industry — Fire Safety is designed to provide the means of interfacing direct shorting devices to the Cerberus™ PRO fire-alarm control panels (FACPs).

Model FDCIO422, which contains microcomputer-chip (*SureWire*) technology and is polarity insensitive, achieves the state of an 'intelligent device' through its highly advanced method of address programming and supervision — combined with its sophisticated, bi-directional FACP communication.

The relays and contact device inputs for Model FDCIO422 are controlled at the same address. For the FACP, the relays and input contacts can be controlled as a separate function. The relay is typically used where control or shunting of external equipment is required.

Model FDCIO422 is designed to monitor Normally Open (N.O) or Normally Closed (N.C) dry contacts. Each interface module reports the status of the (N.O) or (N.C) contacts to the FACP.

### Specifications

Model FDCIO422 is used for the connection of up to two (2) independent 'Class A' or four (4) independent 'Class B,' dry and N.O configurable contacts. Input lines can be supervised for open, short and ground-fault conditions (depending on end-of-line [EOL] termination resistor and class configuration).

Inputs can independently be configured via the FACP for *Alarm, Trouble, Supervisory* or *Status* zones.

Model FDCIO422 has four (4) programmable outputs with four (4) potential-free latching-type 'Form A' (dry) relay contacts for fire-control installations.

The FDnet module provides supervised, power-limited power supply for Model FDCIO422. The four (4) input / (4) output interface module provides status indication per LED for each input / output, plus one (1) LED for general device status:

- Four (4) EOL devices (470 ohms)
- Three (3) separators to separate power-limited wiring from non-power limited wiring

Quad Interface Module **9605**

## Specifications — (continued)

Separators are delivered in the following sizes:

- ✓ 4-x-11/16-inch back box
- ✓ 4-x-11/16-inch extension ring

**Note:** Optional 5" back boxes are available exclusively via Randl Industries, Inc.

Model FDCIO422 has a multi-color LED that flashes GREEN when operating in 'normal' (standby) condition; AMBER if unit is in a *Trouble* event, and RED to indicate a change of event status.

Model FDCIO422, which is fitted with screw terminals for connection to an addressable circuit, is fully compatible on the same circuits with all intelligent Siemens 'H'-series detectors; 'HMS'-series addressable manual stations, or any other addressable intelligent modules, such as Model HZM or Model HCP.

### Model DPU

Model FDCIO422 is compatible with the Siemens field-device programmer / test unit (Model DPU), which is a compact, portable, menu-driven accessory for electronically programming and testing detectors, easily and reliably.

Model DPU eliminates the need for cumbersome, unreliable mechanical programming methods — such as dials or rotary switches — and reduces installation and service costs by electronically programming and testing the detector prior to installation (via the interface's microcomputer-chip, non-volatile memory).

For proper operation of Model DPU, the technician selects the accessory's program mode, and enters the desired address. In turn, Model DPU automatically sets and verifies the address, as well as tests the detector. When in the 'test' mode, Model DPU will perform a series of diagnostic tests without altering the address or other stored data, allowing technicians to determine if the detector is operating properly.

Model DPU operates on AC power or rechargeable batteries, providing flexibility and convenience in programming and testing equipment from practically any location. Further, vibration, corrosion and other conditions that deteriorate mechanical-addressing mechanisms are no longer a cause for concern.

## Application

NFPA-guideline spacing is based on ideal conditions — namely: smooth ceiling, no air movement, and no physical obstructions between the fire source and the detector.

Do not mount interface modules in areas close to ventilating or air-conditioning outlets. Exposed joists or beamed ceilings may also effect safe spacing limitations for Model FDCIO422. It is mandatory to precisely follow NFPA 72 regulations, as well as applying professional engineering judgment, regarding interface locations and spacing.

## Electrical Ratings

<b>Voltage Rating:</b>	12VDC — 32VDC
<b>Maximum Voltage:</b> (FDnet / Cnet modules)	32VDC
<b>Operating current:</b> (quiescent)	1mA
<b>Peak Current:</b>	192mA, max.

### Supervised switch ratings

<b>Monitoring Voltage:</b>	3VDC
<b>Cable-length input:</b>	200 feet (61 meters), max.
<b>Input-shielding cable-length range:</b>	30 ft — 200 ft (9.14m — 61m)
<b>C line-to-line:</b>	0.02 $\mu$ F, max.
<b>C line-to-shield:</b>	0.04 $\mu$ F, max.
<b>Line Sizes</b> American Wire Gauge (AWG)	14 AWG, max; 18 AWG, min.

## Technical Data

<b>Communication Protocol:</b>	FDnet / Cnet (supervised signaling-line circuit, power limited)		
<b>Operating Temp. Range:</b>	-22 — +140 °F (-30 — +60 °C)		
<b>Relay Outputs</b>	<b>Normally Open</b>	2 -x- 7 Amps ('Out' B, C)	
	<b>Normally Closed</b>	1 -x- 8 Amps ('Out' C)	
<b>Relative Humidity:</b>	5 — 85 % (non freezing and condensing at low temperature)		
<b>PHYSICAL CHARACTERISTICS</b>	<b>Color:</b>	Carrier: ~RAL 9017	
	<b>Cage Cover:</b>	Transparent	
	<b>Cage:</b>	~RAL 9017	
	<b>Faceplate:</b>	White	
	<b>Dimensions: { W -x- H -x- D }</b>	4" -x- 4.7" -x- 1.2" (12 cm. -x- 12 cm. -x- 3.1 cm.)	
	<b>Weight:</b>	3 Lbs. (1.12 kgs.)	
<b>Volume: (cage and carrier)</b>	11.7 inch <sup>3</sup>		

## 8701 Intelligent Monitoring Module

### Features

#### Intelligent Interface Modules for use with MPC-6000 & 7000 Control Panels

- Interfaces and Supervises Normally Open Contacts
- Compact Size Allows Mounting in Single Gang Box Behind Equipment
- Polarity Insensitive Technology
- Innovative Technology Supports Comprehensive System and Interface Communication
- Dynamic Supervision
- Two Wire Operation
- 8720 Device Program/Test Unit Electronically Programs and Verifies Device's Address and Tests Device's Functionality
-  Listed, CSFM and NYMEA Approved

### Introduction

The FARADAY 8701 Intelligent interface module is designed to provide the means of interfacing direct shorting devices to the MPC-6000 & 7000 initiating circuit.

The 8701 Intelligent interface module provides the market's most advanced method of address programming and supervision, combined with sophisticated control panel communication. Each 8701 interface module incorporates microcomputer chip technology and its sophisticated bi-directional communication capabilities with the control panel.

### Description

The 8701 is designed to monitor a normally open dry contact and reports the contact's status to the control panel.

The device's microcomputer chip has the capacity of storing, in memory, identification information as well as important operating status information.

FARADAY innovative technology allows all 8701 intelligent interface modules to be programmed by



using the 8720 Device Program/Test Unit. The 8720 is a compact, portable, menu driven accessory that makes programming and testing an interface device faster, easier and more dependable than previous methods. The 8720 eliminates the need for mechanical addressing mechanisms, such as program jumpers, DIP switches or rotary dials, because it electronically sets the 8701 interface's address into the interface's microcomputer chip non-volatile memory. Vibration, corrosion and other conditions that deteriorate mechanical addressing mechanisms are no longer a cause for concern. This 8701 is connected to the program/tester with the programming cable provided with the tester. This programming cable utilizes two (2) alligator clip connectors to attach to the 8701.

The 8701 Series has five leads, one for grounding, which are wired to the system with user supplied wire nuts.

---

The 8701 is fully compatible on the same circuit with detectors, addressable manual stations or any addressable intelligent modules.

All 8701 intelligent interface modules have been UL and ULC Listed.

Environmental operating conditions for all 8701 modules are 32°F (°C) to 120°F (49°C) with a relative humidity of not greater than 93% non-condensating.

## Ordering Information

Model	Description	Shipping oz.	Weight kg.	Part No.
8701	Single Input	3.5	.1	500-034000FA

## Electrical Ratings

Current Draw (Active or Standby): 1mA



Siemens Building Technologies, Inc.  
8 Fernwood Road • Florham Park, NJ 07932  
Tel: (973) 593-2600 • Fax: (973) 593-6670  
Web: [www.faradayfirealarms.com](http://www.faradayfirealarms.com)

**WARNING** - The information contained in this document is intended only as a summary and is subject to change without notice. The devices described in this document have specific instruction sheets which cover various technical, limitation and liability information. Copies of these instruction sheets and the General Product Warning and Limitations Document, which also contains important information, are provided with the product and are available from the Manufacturer. Information contained in these documents should be consulted before specifying or using the product. For further information or assistance concerning particular problems contact the Manufacturer.

**High Security Industrial/Government Key Box**

Recessed Mount  
 with Face Flange



Surface Mount

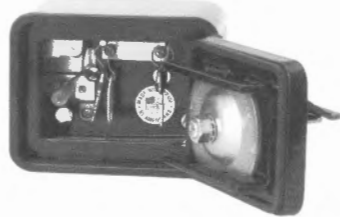

The number one high-security KNOX-BOX® is used for most commercial applications including businesses, schools, government and public buildings, community associations and apartment complexes. The 3200 Series KNOX-BOX holds keys, access cards and other small items necessary for emergency access.

The hinged-door 3200 Series KNOX-BOX is more convenient than the lift-off door version because it allows single-handed operation and opened or closed, it's all one unit.

**Features and Benefits**

- Holds up to 10 keys and access cards in interior compartment
- Ensures high security. Box and lock are UL® Listed
- Includes a Knox-Coat® proprietary finishing process that protects Knox products up to four times better than standard powder coat
- Resists moist conditions with a weather resistant door gasket
- Hinged door allows single-handed operation
- Colors: Black, Dark Bronze or Aluminum
- Weight: Surface mount - 8 lbs.  
 Recessed mount - 9 lbs.

**Options**

- Alarm tamper switches (UL Listed)
- Recessed Mounting Kit (RMK) for recessed models only
- Inside switch for use on electrical doors, gates and other electrical equipment

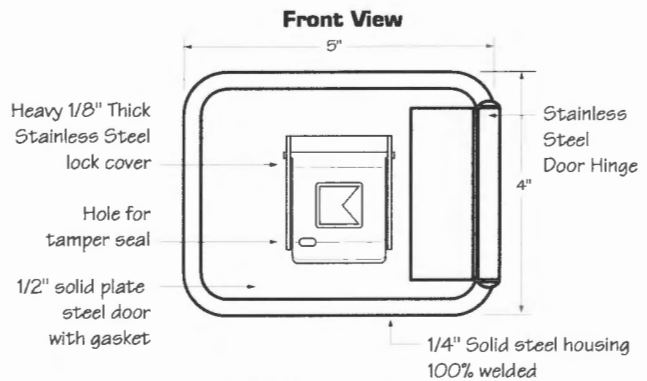

**3200 Surface Mount**

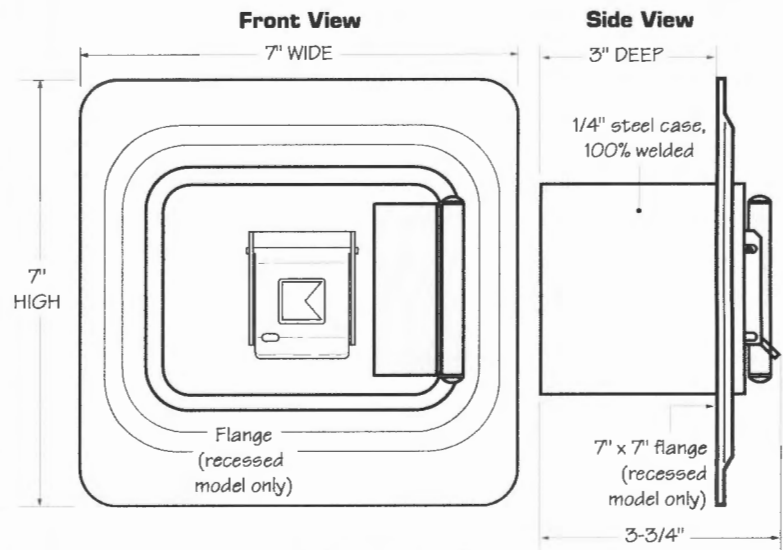

**3200 Recessed Mount**

**Ordering Specifications**

*To insure procurement and delivery of the 3200 Series KNOX-BOX, it is suggested that the following specification paragraph be used:*

**KNOX-BOX** surface/recessed mount with hinged door, with/without UL Listed tamper switches. 1/4" plate steel housing, 1/2" thick steel door with interior gasket seal and stainless steel door hinge. Box and lock UL Listed. Lock has 1/8" thick stainless steel dust cover with tamper seal mounting capability.

Exterior Dimensions: Surface mount body- 4"H x 5"W x 3-3/4"D  
 Recessed mount flange- 7"H x 7"W

Lock: UL Listed. Double-action rotating tumblers and hardened steel pins accessed by a biased cut key.

Finish: Knox-Coat® proprietary finishing process

Colors: Black, Dark Bronze or Aluminum

P/N: 3200 Series KNOX-BOX (mfr's cat. ID)

Mfr's Name: **KNOX COMPANY**



**Suggested minimum mounting height  
6 feet above ground**

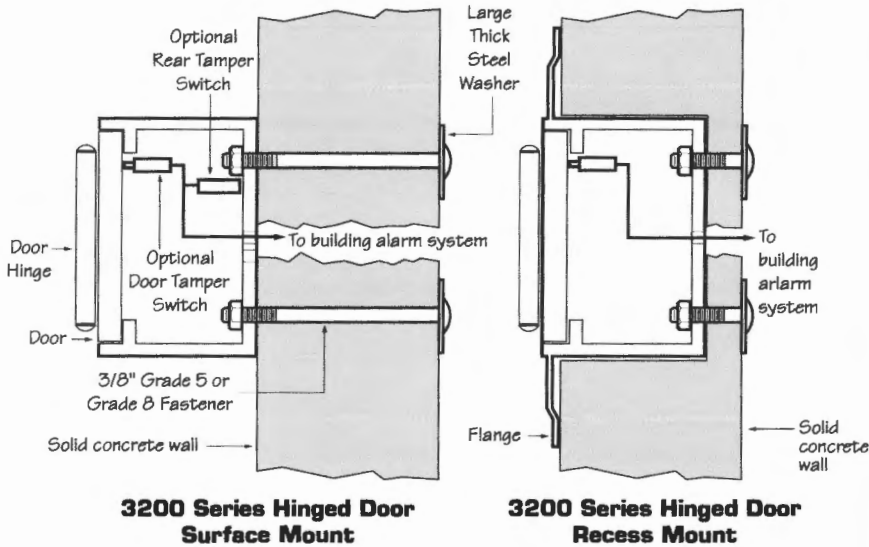

**3200 Series Hinged Door  
Surface Mount**

**3200 Series Hinged Door  
Recess Mount**

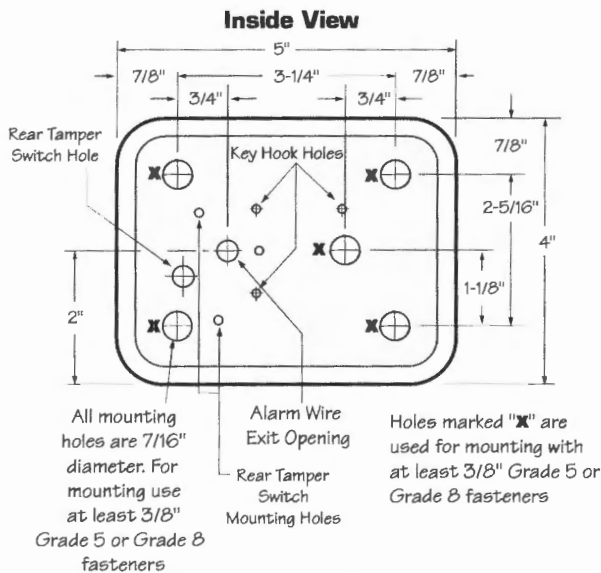

**Attention: KNOX-BOX® is a very strong device that MUST be mounted properly to ensure maximum security and resist physical attack.**

**Knox® Rapid Entry System**

The Knox Company manufactures a complete line of high security products including Knox-Box key boxes, key vaults, cabinets, key switches, padlocks, locking FDC caps, plugs and electronic master key security systems. For more information or technical assistance, please call Customer Service at 1-800-552-5669.

**Recessed Mounting Kit**

The 3200 Recessed Mounting Kit (RMK) is used for recessed models only. It contains a shell housing and mounting hardware to be cast-in-place in new concrete or masonry construction. After construction is completed, the KNOX-BOX mounts inside the RMK. The RMK may only be used in new concrete or masonry construction.

**Installation In Cast Concrete**

The optional Recessed Mounting Kit is for use in new concrete or masonry construction only. The kit includes a shell housing and mounting hardware to be cast-in-place. The KNOX-BOX is mounted into the shell housing after construction is completed.

**Dimensions**

Rough-in Dimensions: 6-1/2"H x 6-1/2"W x 5"D

**IMPORTANT:** Care should be taken to insure that the front of the RMK shell housing, including the cover plate and screw heads, is flush with the finish wall. The RMK must be plumbed to insure vertical alignment of the vault.

**Recessed Mounting Using  
Recessed Mounting Kit (RMK)**

