



**5600 Series**  
**Mechanical Heat Detector**  
**Single Circuit: 5601P, 5602, 5603, 5604**  
**Dual Circuit: 5621, 5622, 5623, 5624**

3825 Ohio Avenue, St. Charles, Illinois 60174  
 1-800-SENSOR2, FAX: 630-377-6495  
 www.systemsensor.com

**Before Installing**

This detector must be installed in compliance with the control panel installation manual and meet the requirements of NFPA 72, and/or the local authority having jurisdiction.

Read this manual carefully before using the detector. This manual should be left with the owner/user of this equipment.

**General Description**

The 5600 series mechanical heat detector is intended for use in property protection applications, or for non-life-safety installations where smoke detection is not practical or appropriate.



For life-safety installations, smoke detectors must be used, in lieu of, or in addition to mechanical heat detectors.

The 5600 series consists of both single- and dual-circuit heat detectors featuring fixed temperature thermal sensors or combination fixed temperature/rate-of-rise sensors, with temperature ratings of 135°F (57°C) or 194°F (90°C).

Markings on the exterior of the detector indicate the specific activation method and temperature rating. All models are identified as either 135°F/57°C or 194°F/90°C. Models equipped with combination fixed temperature/rate-of-rise sensors are marked FX/ROR. Fixed temperature only models are marked FX.

**Table 1. 5600 Series Mechanical Heat Detectors**

Model No.	Circuit	Temperature Rating	Thermal Sensor	UL Maximum Spacing (10-foot ceiling)
5601P	Single	135°F (57°C)	Fixed Temperature/Rate of Rise	50-foot x 50-foot
5602	Single	194°F (90°C)	Fixed Temperature/Rate of Rise	50-foot x 50-foot
5603	Single	135°F (57°C)	Fixed Temperature	25-foot x 25-foot
5604	Single	194°F (90°C)	Fixed Temperature	25-foot x 25-foot
5621	Dual	135°F (57°C)	Fixed Temperature/Rate of Rise	50-foot x 50-foot
5622	Dual	194°F (90°C)	Fixed Temperature/Rate of Rise	50-foot x 50-foot
5623	Dual	135°F (57°C)	Fixed Temperature	25-foot x 25-foot
5624	Dual	194°F (90°C)	Fixed Temperature	25-foot x 25-foot

**NOTE:** Refer to NFPA72 guidelines for spacing reductions when ceiling heights exceed 10 feet.

**Non-Resettable Fixed Temperature Sensor**

The fixed temperature element reacts to heat by responding to a specific temperature setting (135°F or 194°F). The detection method is based on the spring action of a metal contact, held to the metal chamber by a fusible alloy. When the temperature reaches the alloy's melting point, the metal contact will depress the diaphragm, causing the electrical contact to close the circuit. The circular external heat collector is released from the detector to visually indicate that the detector has been activated.

**NOTE:** 5600 series Fixed Temperature models (5603, 5604, 5623, and 5624) are non-resettable, and cannot be tested.

**Self-Restoring Rate-of-Rise (ROR) Sensor**

The rate-of-rise element responds to a rapid rise of temperature, approximately 15°F (8.3°C) per minute. As the temperature rises, the air within the sealed chamber expands. Should the chamber air expand faster than it can escape through the calibrated vent, the diaphragm is depressed, and the electrical contact closes the circuit.

**NOTE:** Only the ROR element of 5600 series combination fixed temperature/ROR models (5601P, 5602, 5621, and 5622) are self-restoring, and may be tested using a hair dryer or heat gun. When testing the ROR element, to prevent the activation of the fixed temperature element, the heat source must not exceed the fixed temperature rating of the detector.

## Mounting Bracket

All 5600 series detectors are equipped with a mounting bracket that includes mounting slots to accommodate single-gang, 3½" octagonal, and 4" octagonal electrical boxes, as well as 4" square boxes equipped with a plaster ring (Figure 1). The mounting bracket is reversible to accommodate flush-mount and surface-mount installations (Figure 2).

**Figure 1. Bracket Mounting Locations:**

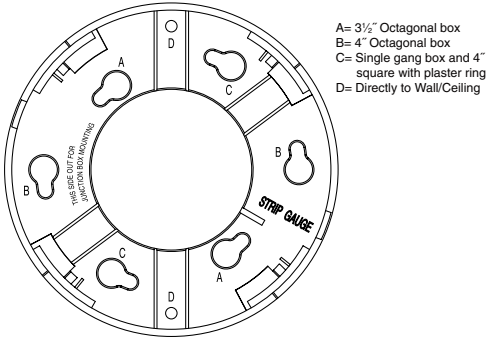

## Wiring Installation Guidelines

All wiring must be installed in compliance with the National Electrical Code, applicable state and local codes, and any special requirements of the local Authority Having Jurisdiction. Proper wire gauges should be used. The conductors used to connect heat detectors to the alarm control panel and accessory devices should be color-coded to reduce the likelihood of wiring errors. Improper connections can prevent a system from responding properly in the event of a fire.

**Figure 3. Wiring Diagram – Single Circuit Models:**

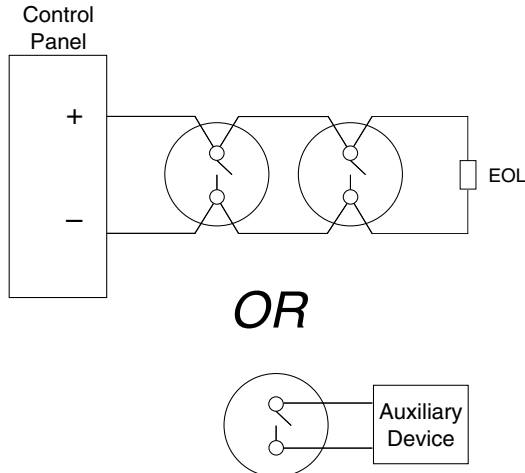

**Figure 2. Reversible Mounting Bracket:**

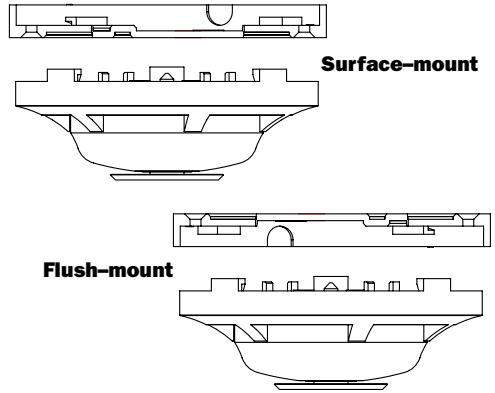

The non-polarized screw terminals on the back of the detector will accept 14–22 AWG wire. For best system performance, all wiring should be installed in separate grounded conduit; do not mix fire alarm system wiring in the same conduit as any other electrical wiring. Twisted pair may be used to provide additional protection against extraneous electrical interference.

Wire connections are made by stripping approximately ¼" of the insulation from the end of the feed wire, inserting it into the proper base terminal, and tightening the screw to secure the wire in place.

**Figure 4. Wiring Diagram – Dual Circuit Models:**

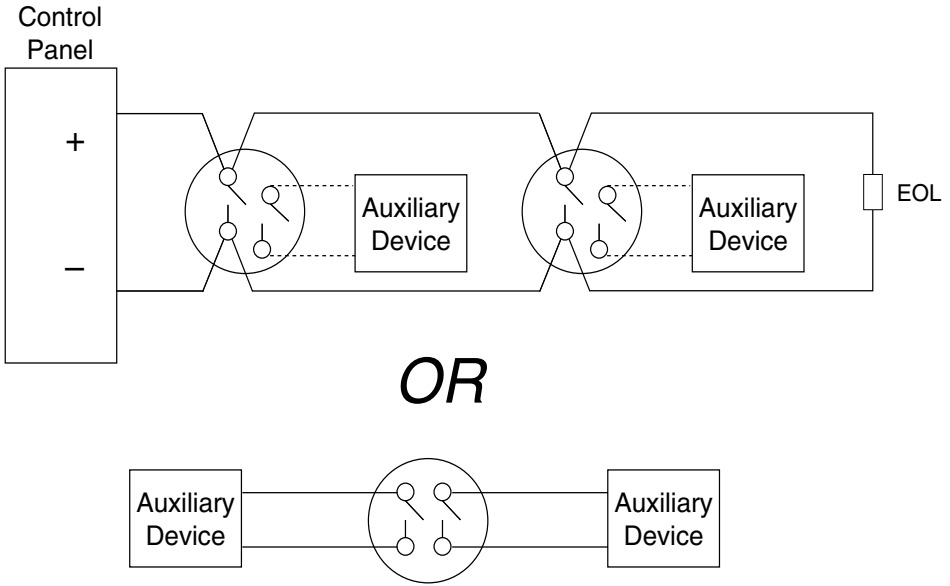

**Installation**

Remove power from the alarm control unit or initiating device circuits before installing detectors.

1. Detach the detector from the mounting bracket by rotating the detector 1/4 turn counter-clockwise.
2. Orient the mounting bracket properly for either a flush- or surface-mount installation (Figure 2).
3. Select the pair of mounting holes suitable for the junction box, (figure 1) and secure the bracket to the box.
4. Connect the wires to the detector per Figure 3 or Figure 4, as applicable.
5. Place the detector onto the mounting bracket by rotating clockwise. The detector will lock into place with a “click”.
6. After all detectors have been installed, apply power to the alarm control unit.
7. Test each detector as described in Testing.
8. Reset all the detectors at the alarm control unit.
9. Notify the proper authorities that the system is in operation.

**Testing/Maintenance**

The rate-of-rise mechanism may be subject to reduced sensitivity over time. Annual testing of the rate-of-rise operation is therefore recommended.

Before testing, notify the proper authorities that maintenance is being performed and the system will be temporarily out of service. Disable the zone or system undergoing maintenance to prevent any unwanted alarms.

Only the ROR element of 5600 series combination fixed temperature/ROR models (5601P, 5602, 5621, and 5622) are self-restoring, and may be tested using a hair dryer or heat gun.

**WARNING**

When testing the ROR element, to prevent the activation of the fixed temperature element, the heat source must not exceed the fixed temperature rating of the detector.

**WARNING**

5600 series fixed temperature models (5603, 5604, 5623, and 5624) are non-resettable, and cannot be tested.

**CAUTION**

When using the RRS-MOD with model 2WTA-B, do not mix the 2WTA-B with other model smoke detectors and dry contact closure devices, including mechanical heat detectors, manual pull stations and waterflow switches. Such mixing can cause a direct short on the auxiliary power terminals, damaging the control panel’s internal circuitry and/or damage devices connected to the initiating device circuit.

---

**Specifications:**

Operating Voltage/Contact Ratings (Resistive):	6 – 125 VAC / 3A 6 – 28 VDC / 1A 125 VDC / 0.3A 250 VDC / 0.1A
Maximum Installation Temperature:	Models 5601P, 5603, 5621, and 5623: 100°F (38°C) Models 5602, 5604, 5622, and 5624: 150°F (65.6°C)
Alarm Temperature:	Models 5601P, 5603, 5621, and 5623: 135°F (57°C) Models 5602, 5604, 5622, and 5624: 194°F (90°C)
Rate-of-Rise Threshold:	15°F (8.3°C) per minute (models 5601P, 5602, 5621, and 5622 only)
Operating Humidity Range:	5 to 95% RH non-condensing
Input Terminals:	14 – 22 AWG
Back Box Mounting:	3½ octagonal 4 octagonal Single gang 4 square with a square to round plaster ring
Dimensions with mounting bracket:	Diameter: 4.57 inches (11.6cm) Height: 1.69 inches (4.3cm)
Weight:	6 oz. (170 grams)

---

**CAUTION**

To prevent the activation of the fixed temperature element, the shipping and storage temperature must not exceed 122°F (50°C).

---

**Please refer to insert for the Limitations of Fire Alarm Systems**

**Three-Year Limited Warranty**

System Sensor warrants its enclosed product to be free from defects in materials and workmanship under normal use and service for a period of three years from date of manufacture. System Sensor makes no other express warranty for the enclosed product. No agent, representative, dealer, or employee of the Company has the authority to increase or alter the obligations or limitations of this Warranty. The Company's obligation of this Warranty shall be limited to the replacement of any part of the product which is found to be defective in materials or workmanship under normal use and service during the three year period commencing with the date of manufacture. After phoning System Sensor's toll free number 800-SENSOR2 (736-7672) for a Return Authorization number, send defective units postage prepaid to: System Sensor, Returns

Department, RA # \_\_\_\_\_, 3825 Ohio Avenue, St. Charles, IL 60174. Please include a note describing the malfunction and suspected cause of failure. The Company shall not be obligated to replace units which are found to be defective because of damage, unreasonable use, modifications, or alterations occurring after the date of manufacture. In no case shall the Company be liable for any consequential or incidental damages for breach of this or any other Warranty, expressed or implied whatsoever, even if the loss or damage is caused by the Company's negligence or fault. Some states do not allow the exclusion or limitation of incidental or consequential damages, so the above limitation or exclusion may not apply to you. This Warranty gives you specific legal rights, and you may also have other rights which vary from state to state.

**FCC Statement**

This device complies with part 15 of the FCC Rules. Operation is subject to the following two conditions: (1) This device may not cause harmful interference, and (2) this device must accept any interference received, including interference that may cause undesired operation.

**NOTE:** This equipment has been tested and found to comply with the limits for a Class B digital device, pursuant to Part 15 of the FCC Rules. These limits are designed to provide reasonable protection against harmful interference in a residential installation. This equipment generates, uses and can radiate radio frequency energy and, if not installed and used in accordance with the instructions, may cause harmful interference to radio communications. However, there is no guarantee that interference will not occur in a particular installation. If this equipment does cause harmful interference to radio or television reception, which can be determined by turning the equipment off and on, the user is encouraged to try to correct the interference by one or more of the following measures:

- Reorient or relocate the receiving antenna.
- Increase the separation between the equipment and receiver.
- Connect the equipment into an outlet on a circuit different from that to which the receiver is connected.
- Consult the dealer or an experienced radio/TV technician for help.