

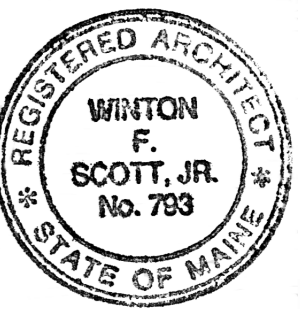

Winton Scott Architects
5 Milk Street
Portland, Maine 04101
207 774 4811
www.wintonscott.com

Architecture / Planning
Preservation Architecture
Interior Architecture



Winton Scott

CABINETS GENERAL NOTES

- 1- CABINET INTERIORS SHALL BE PREFINISHED WITH MELAMINE
- 2- ALL VISIBLE FACES, INCLUDING KNEE SPACES SHALL HAVE HPDL FINISH WITH 3MM EDGE BANDING UNLESS NOTED OTHERWISE.
- 3- SHELVES BEHIND DOORS SHALL BE PREFINISHED WITH MELAMINE.
- 4- OPEN SHELVING (VISIBLE) SHALL HAVE HPDL FINISH WITH 3MM EDGE BANDING.
- 5- PROVIDE 1 GROMMET MIN. AT EACH WORKSTATION AND OPEN COUNTER.

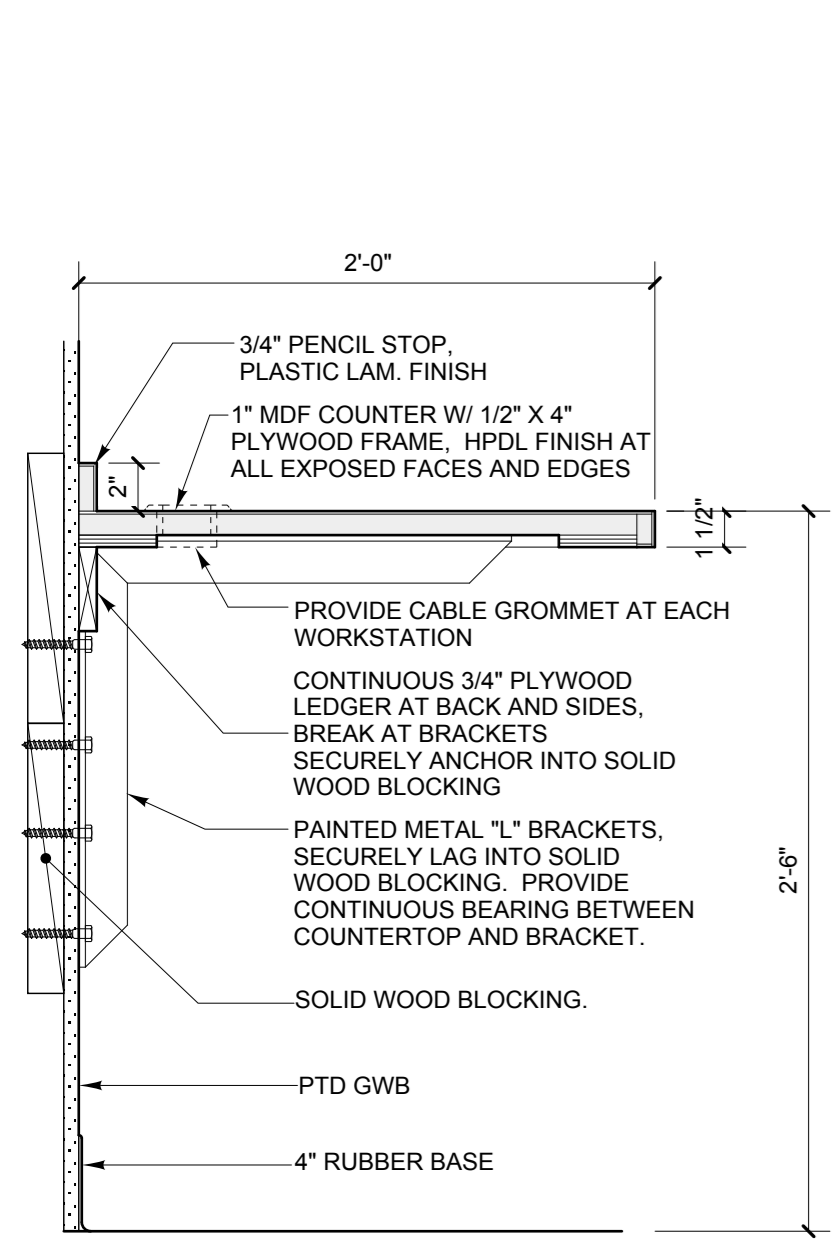

A COUNTER DETAIL W/ BRACKETS
SCALE: 1 1/2" = 1'-0"

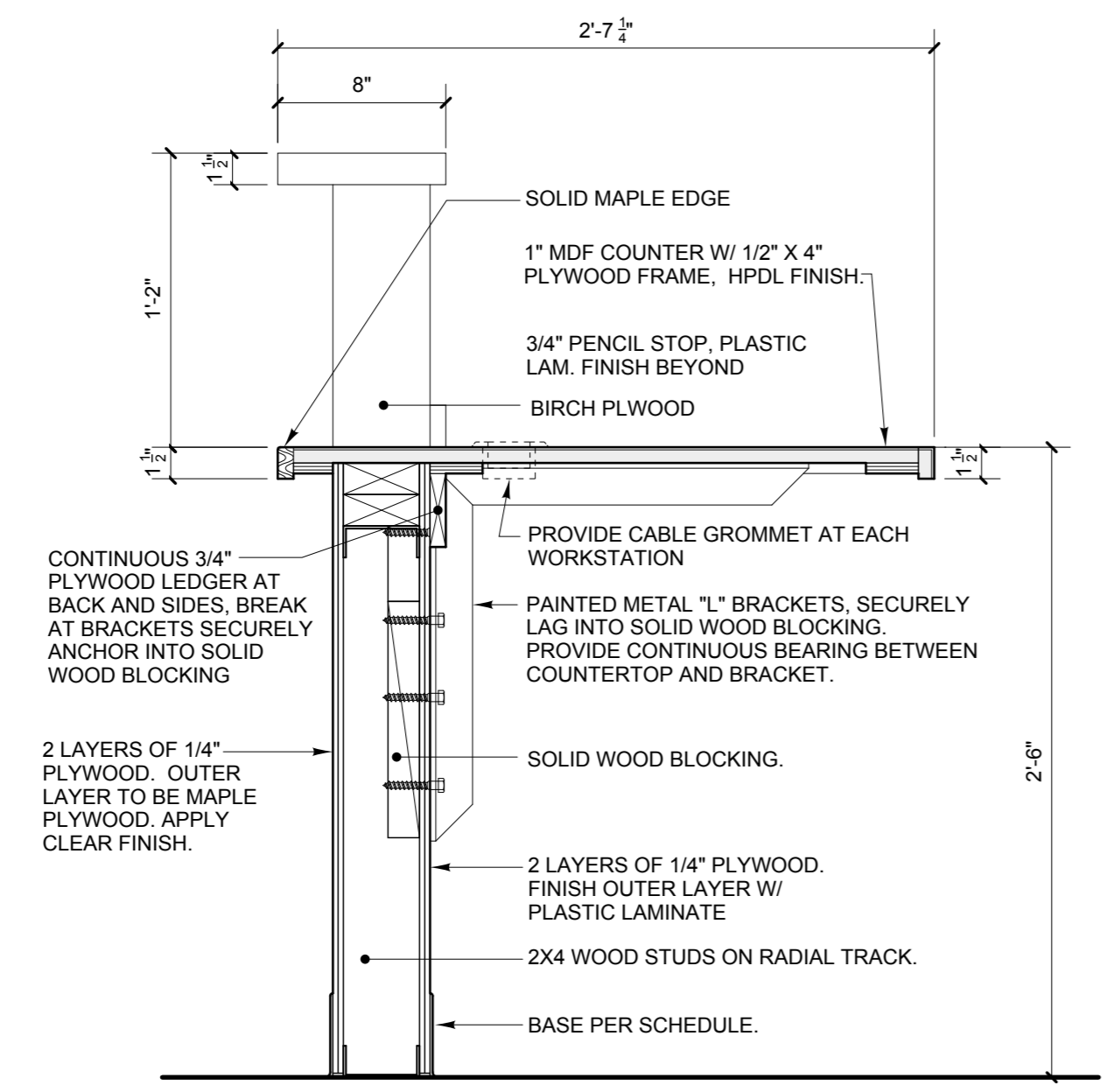

B SECTION DETAIL AT CHECK-IN / OUT 103
SCALE: 1 1/2" = 1'-0"

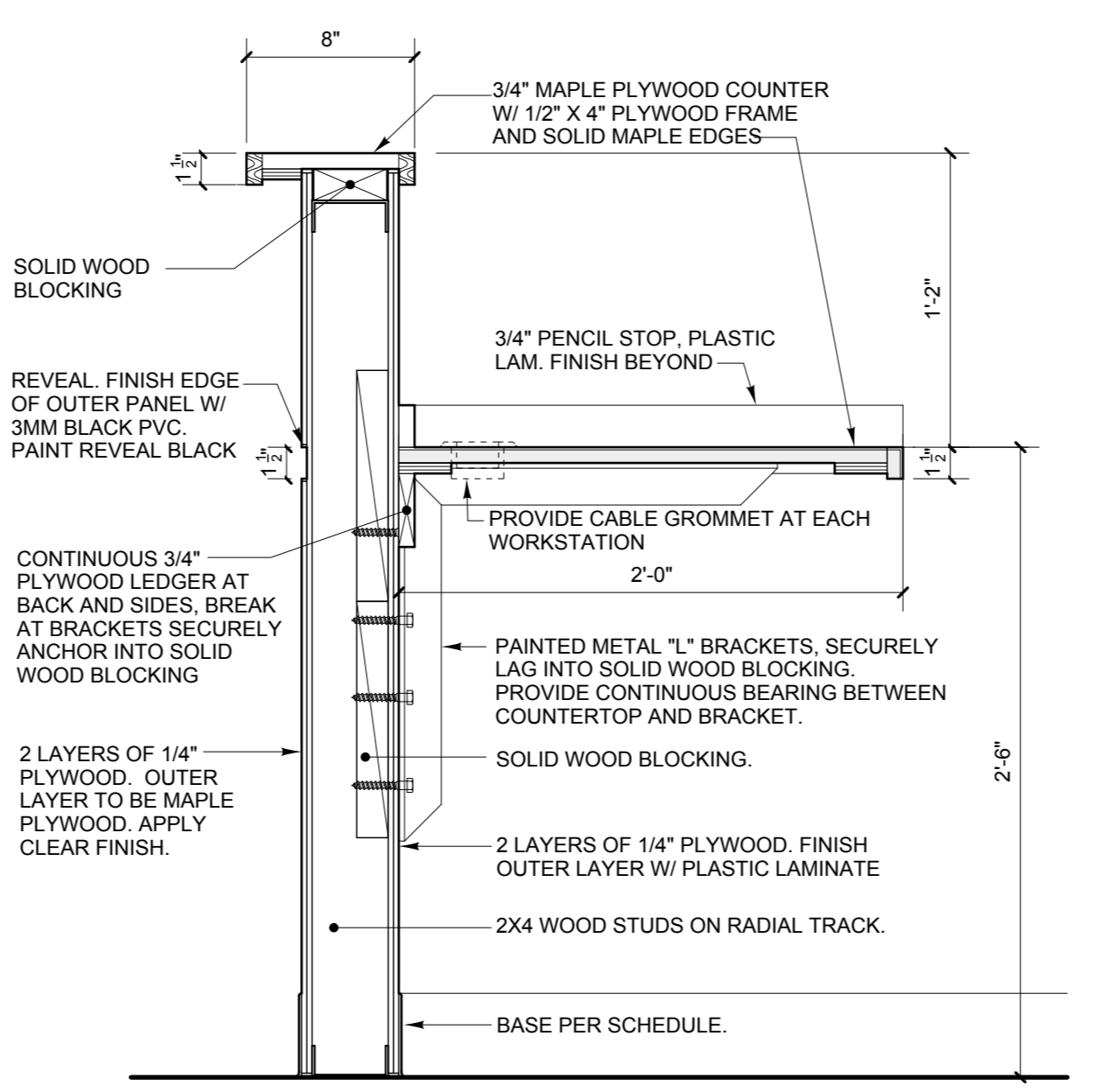

C SECTION DETAIL AT CHECK-IN / OUT 103
SCALE: 1 1/2" = 1'-0" SIMILAR AT REFER. COORD. 105

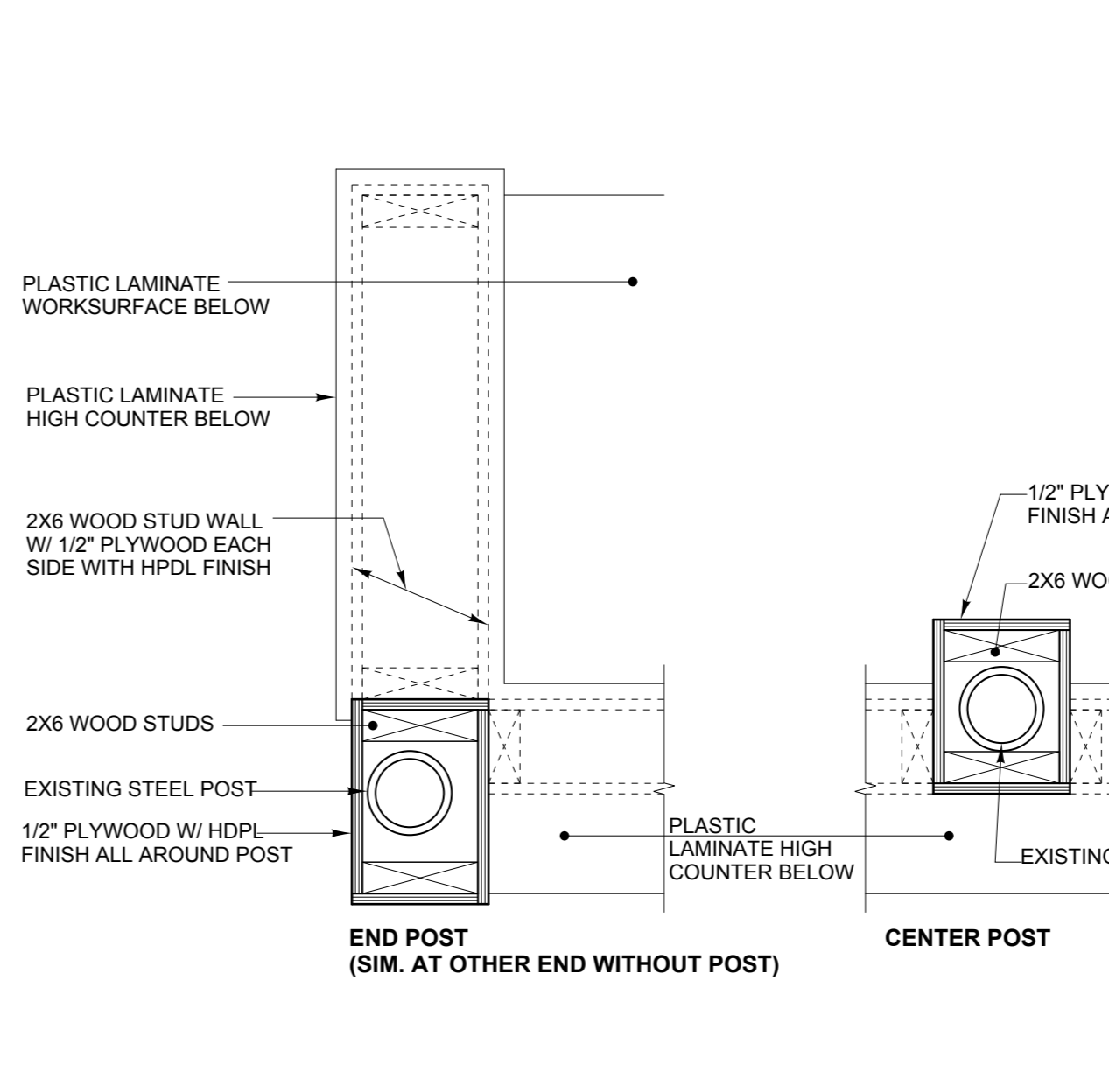

D PLAN DETAIL AT MED ASSIST. 109
SCALE: 1 1/2" = 1'-0"

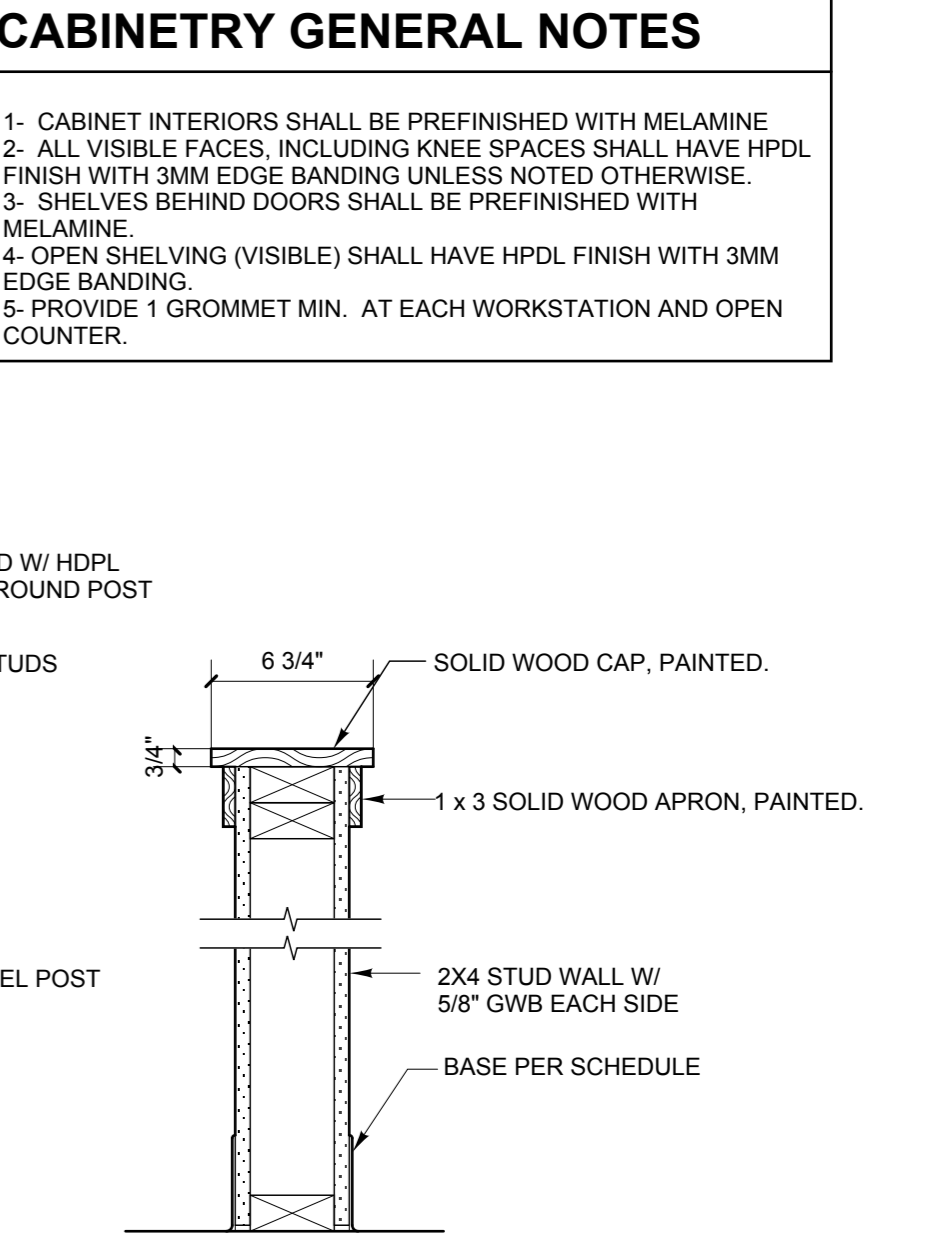

E KNEE WALL DETAIL
SCALE: 1 1/2" = 1'-0"

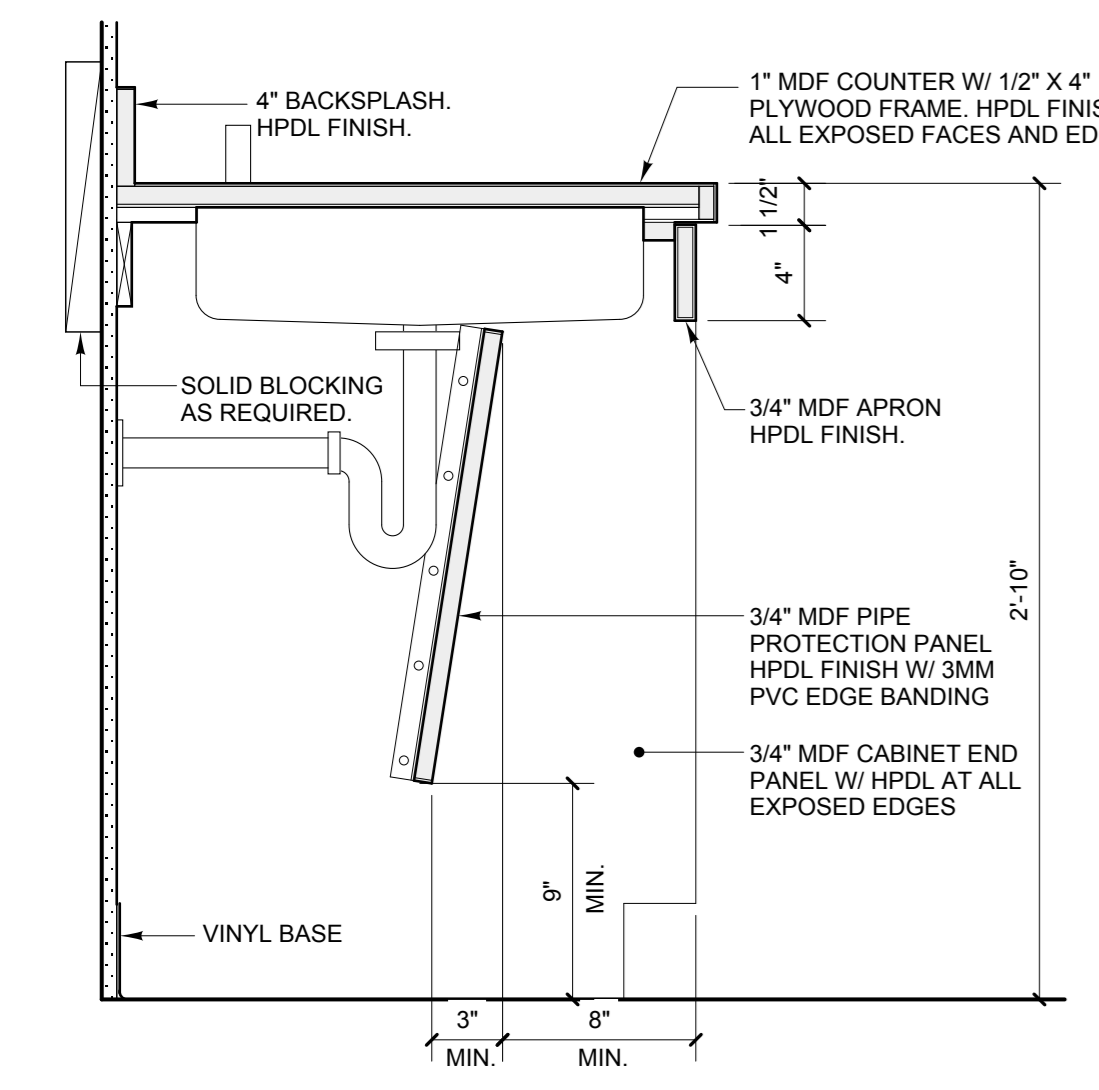

F SECTION DETAIL AT SINK
SCALE: 1 1/2" = 1'-0"

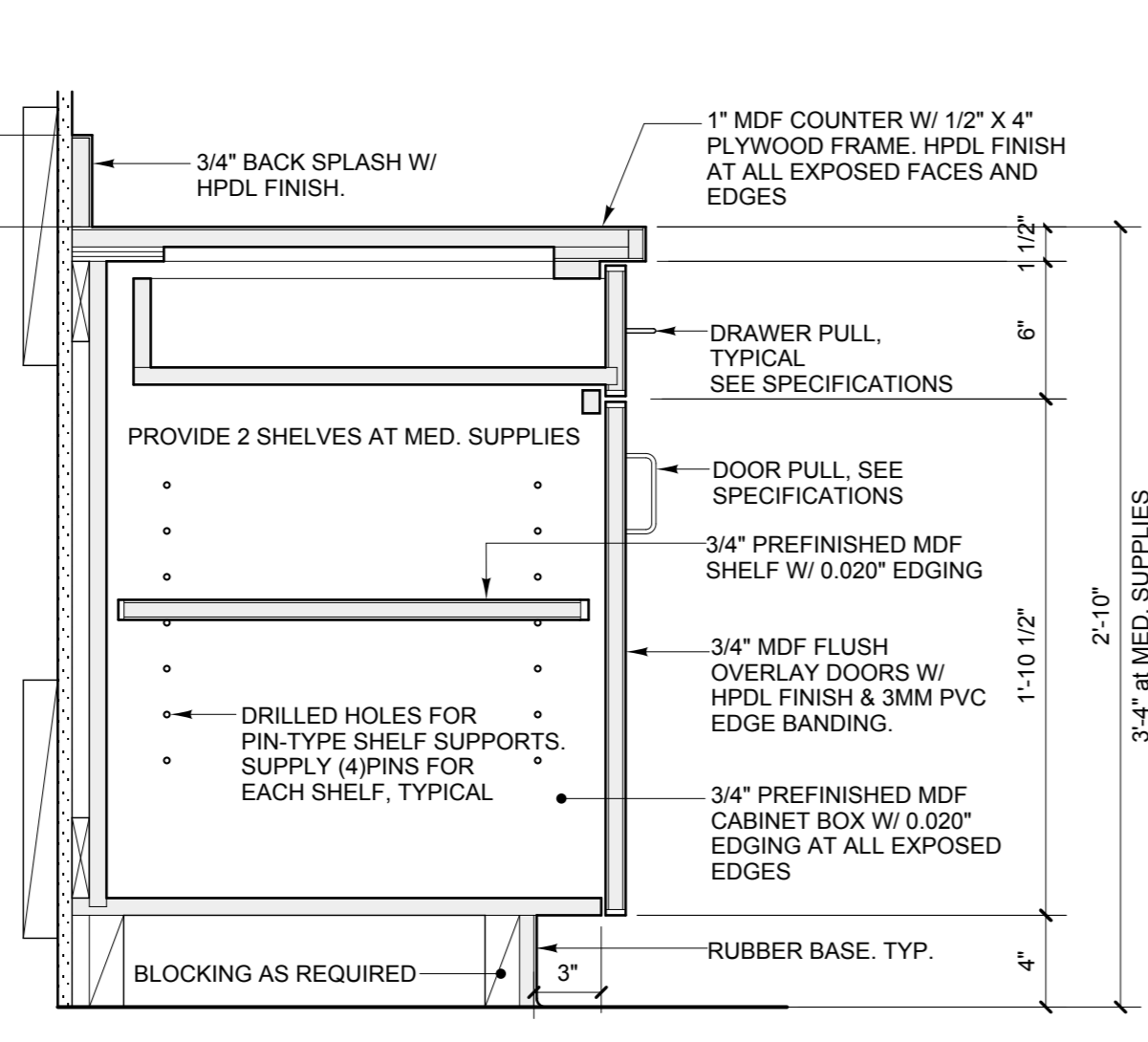

G BASE CABINET DETAIL AT BREAK ROOM
SCALE: 1 1/2" = 1'-0"

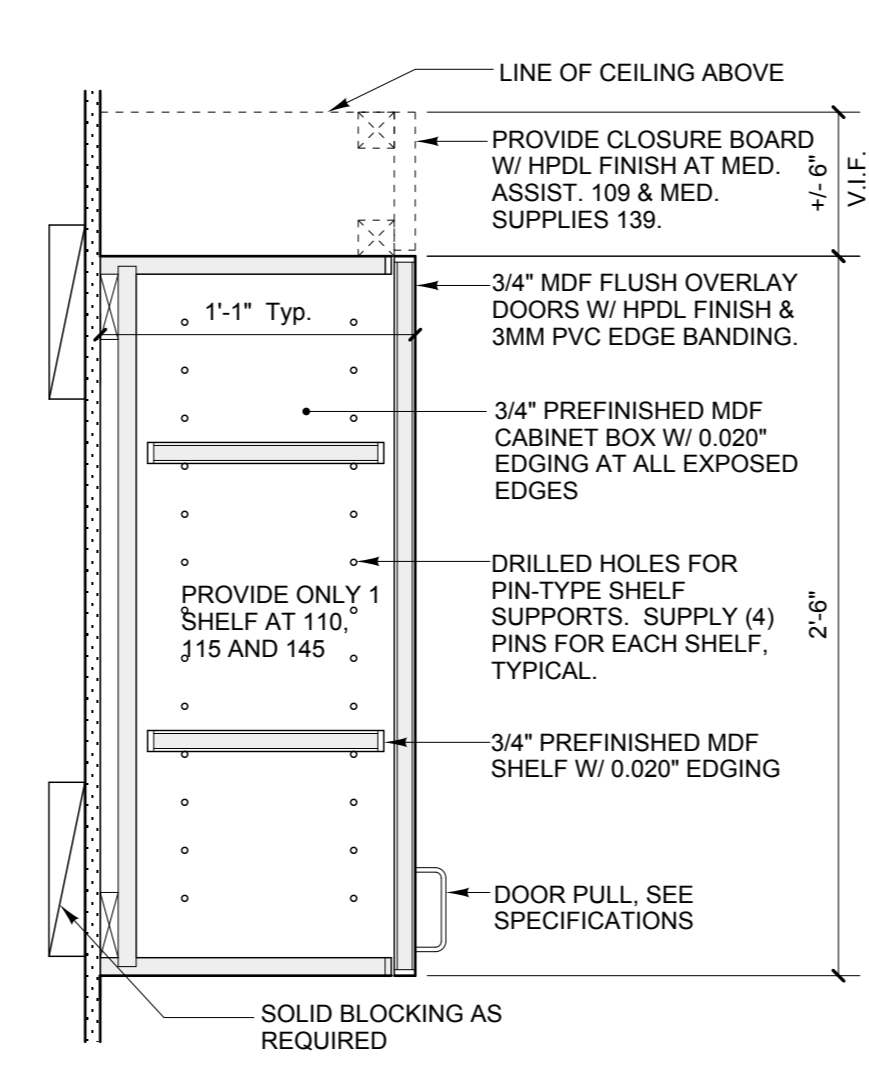

H UPPER CABINET DETAIL
SCALE: 1 1/2" = 1'-0"

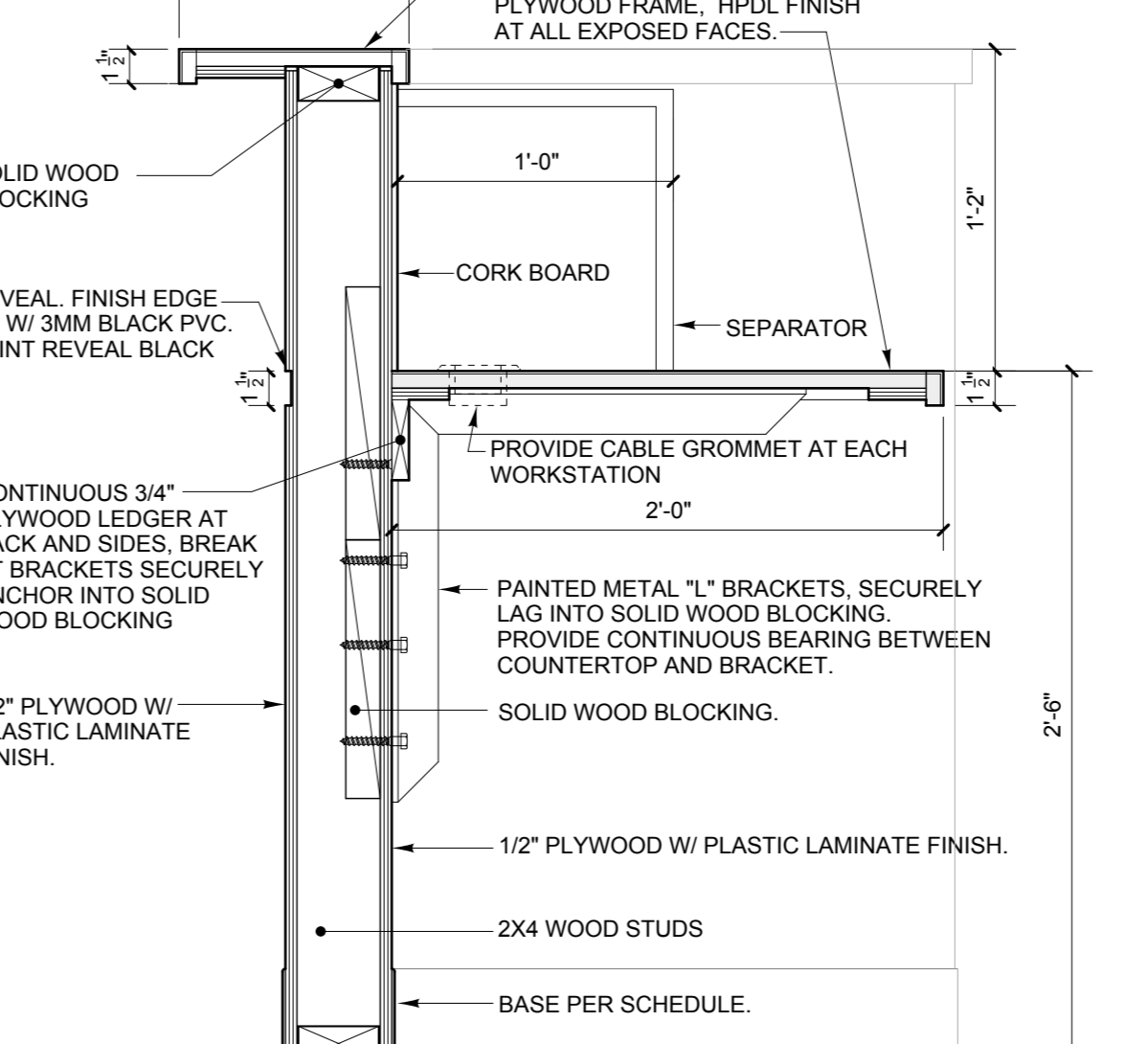

I SECTION DETAIL AT MED. ASSIST. 109
SCALE: 1 1/2" = 1'-0"

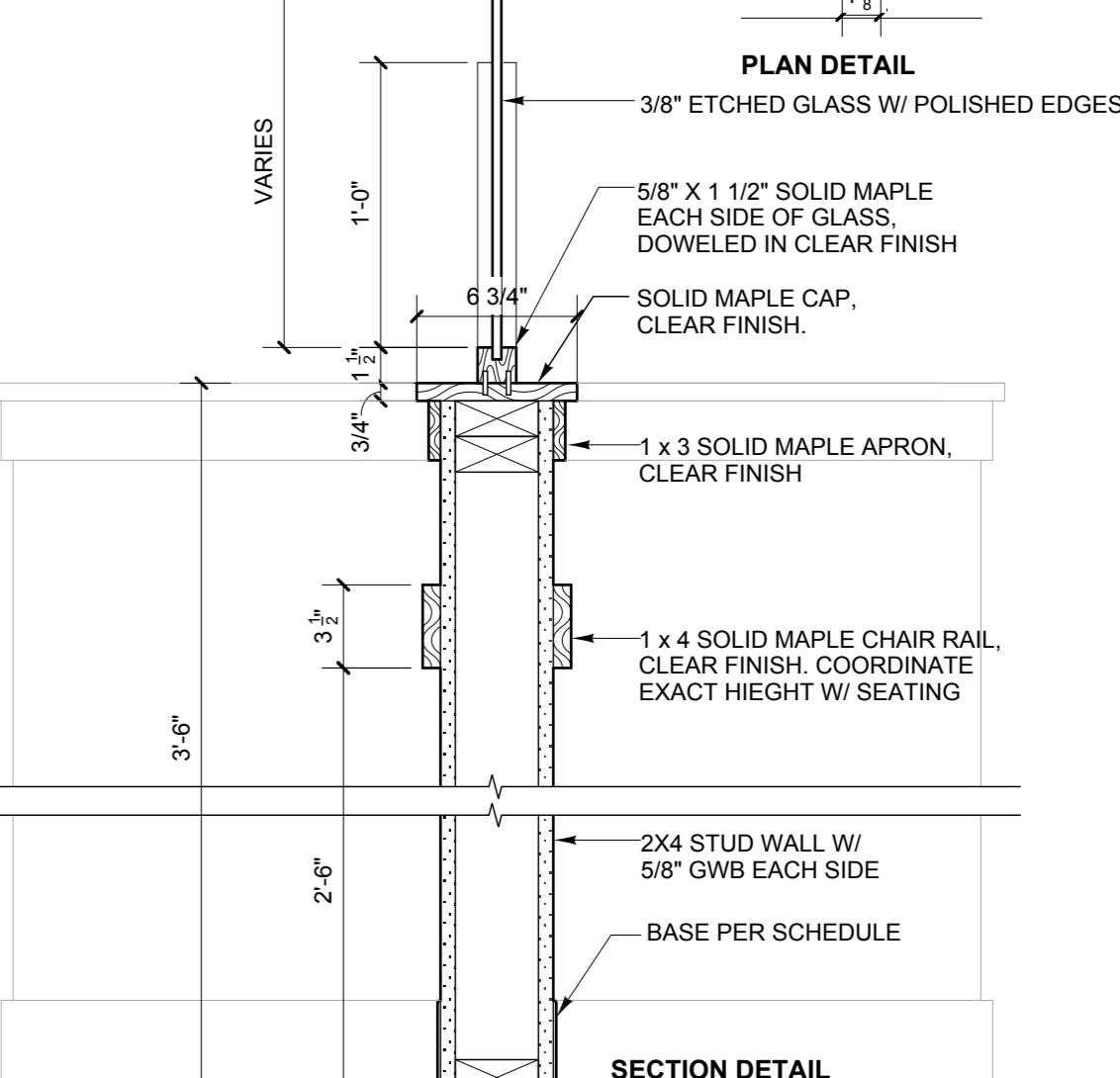

J KNEE WALL DETAIL
SCALE: 1 1/2" = 1'-0"

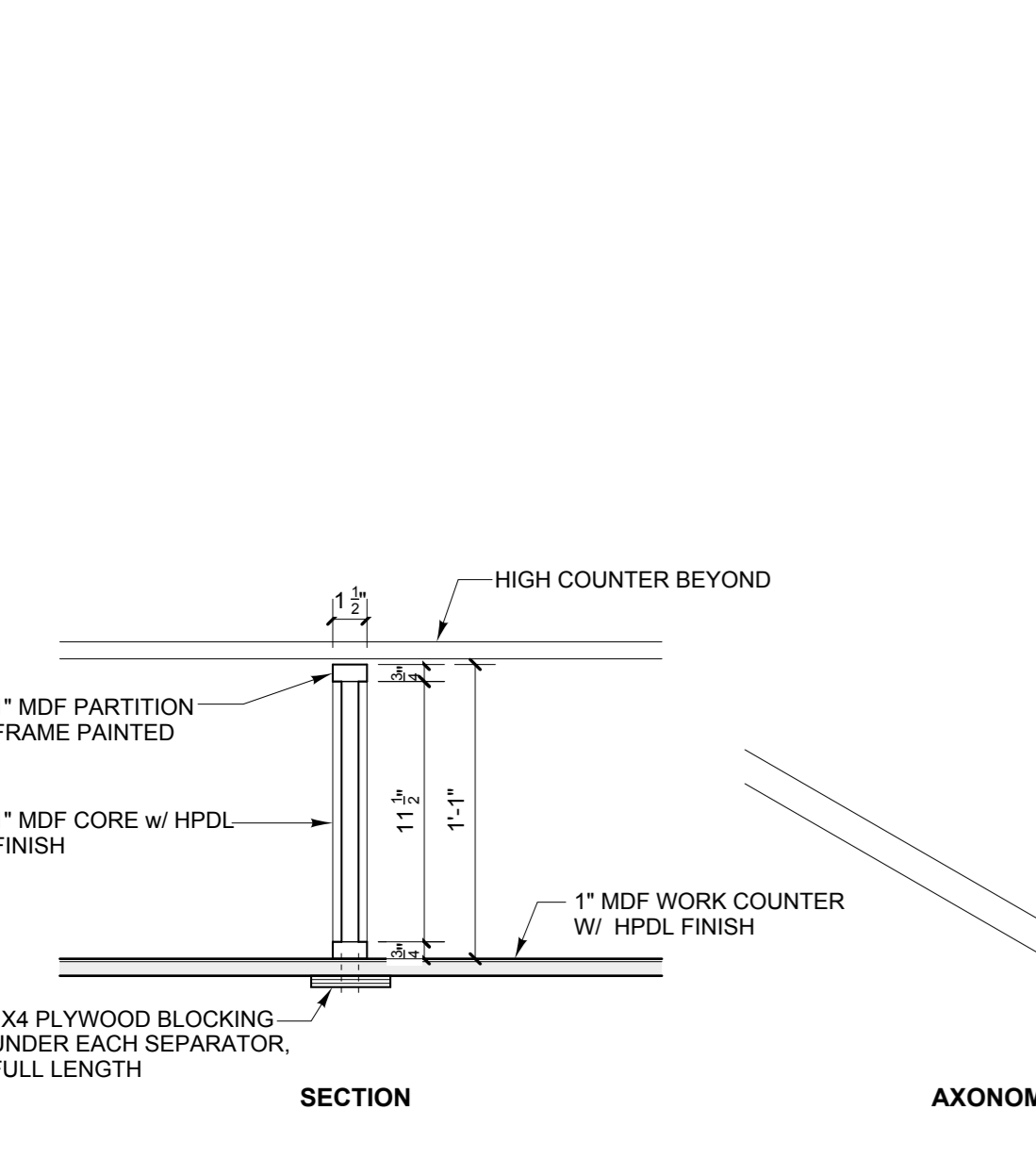

K DETAIL AT SEPARATOR
SCALE: 1 1/2" = 1'-0"

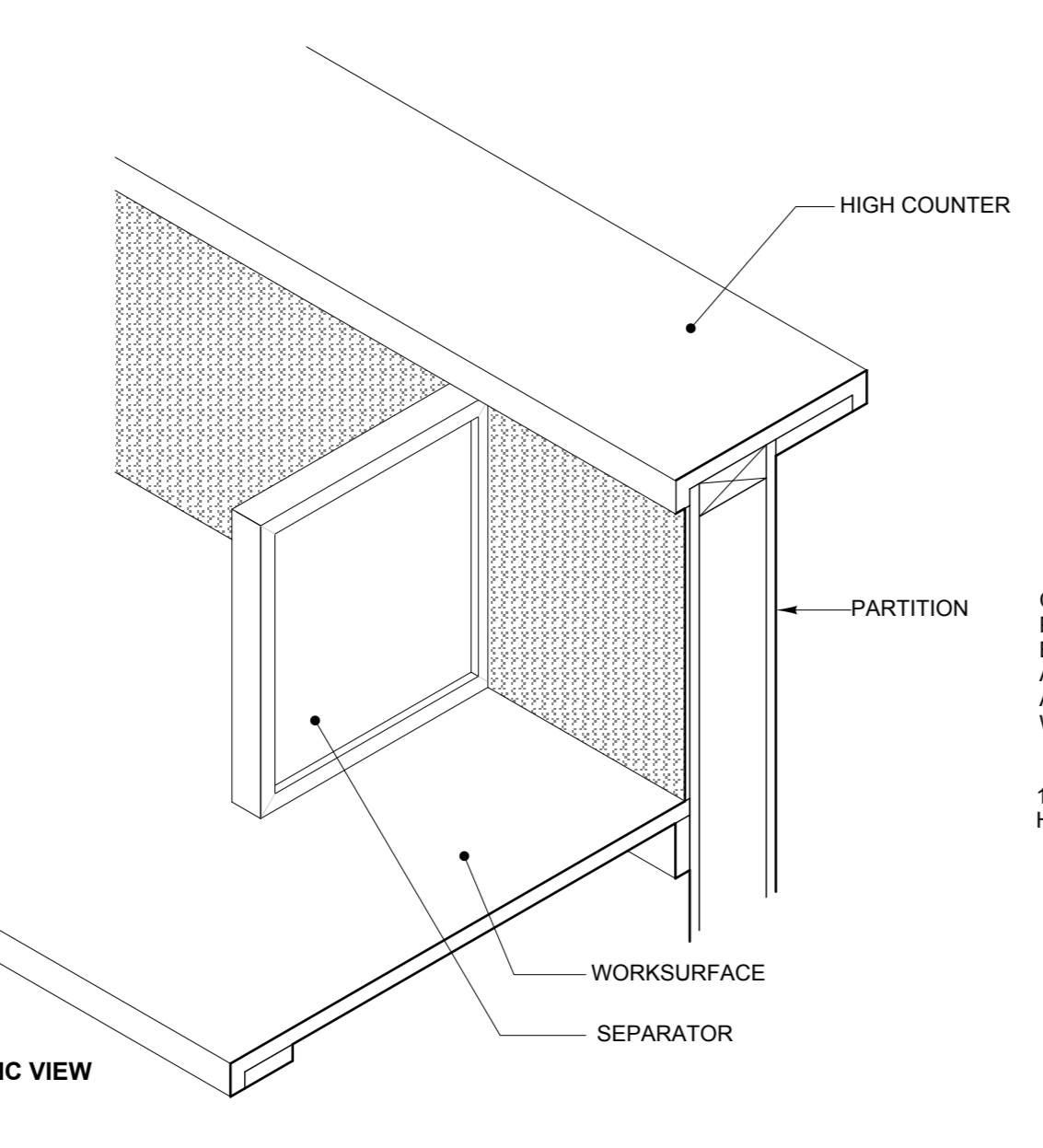

L SECTION DETAIL AT PRIVATE RECEPTION 104
SCALE: 1 1/2" = 1'-0"

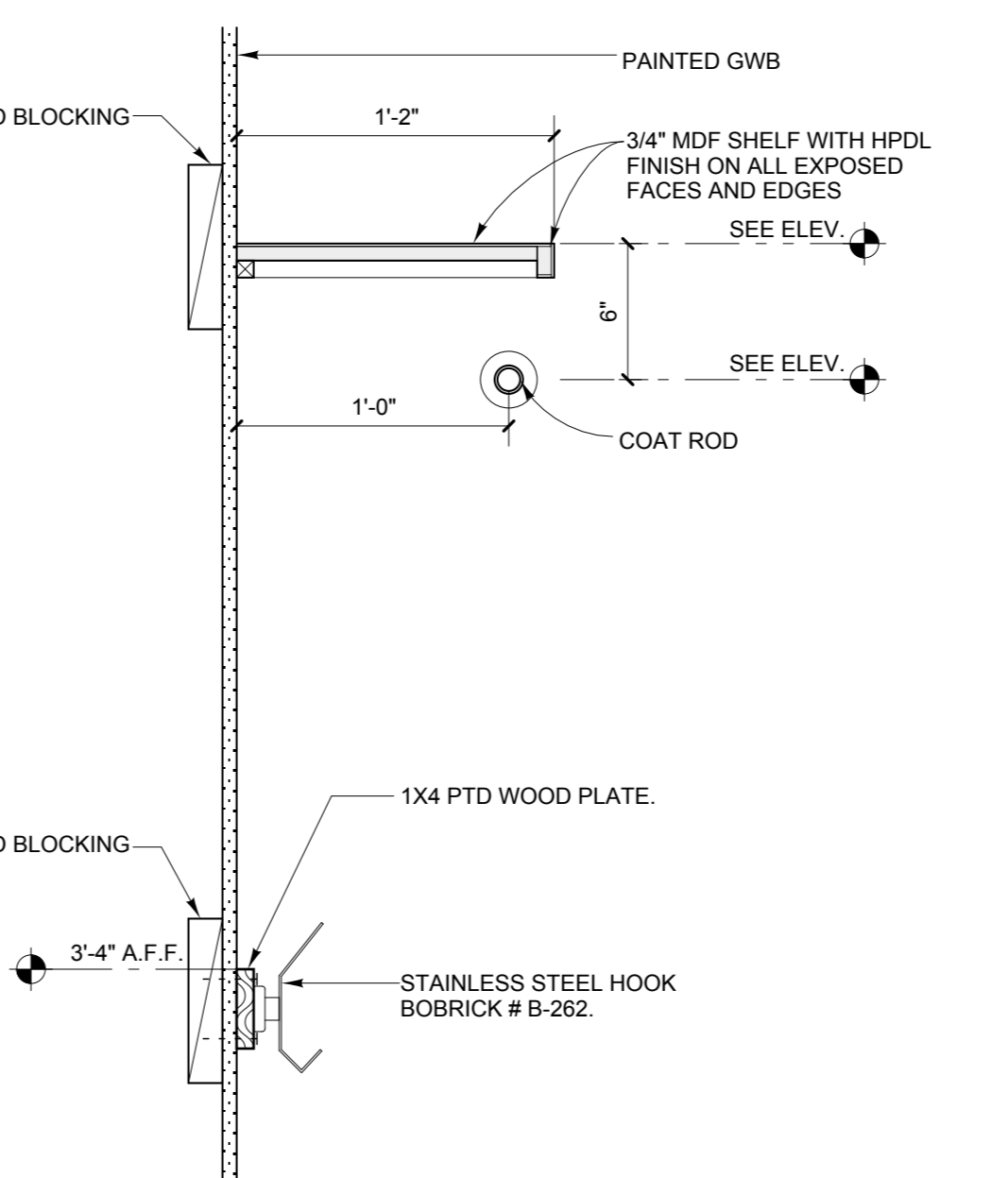

M TYPICAL COAT CLOSET DETAIL
SCALE: 1 1/2" = 1'-0"

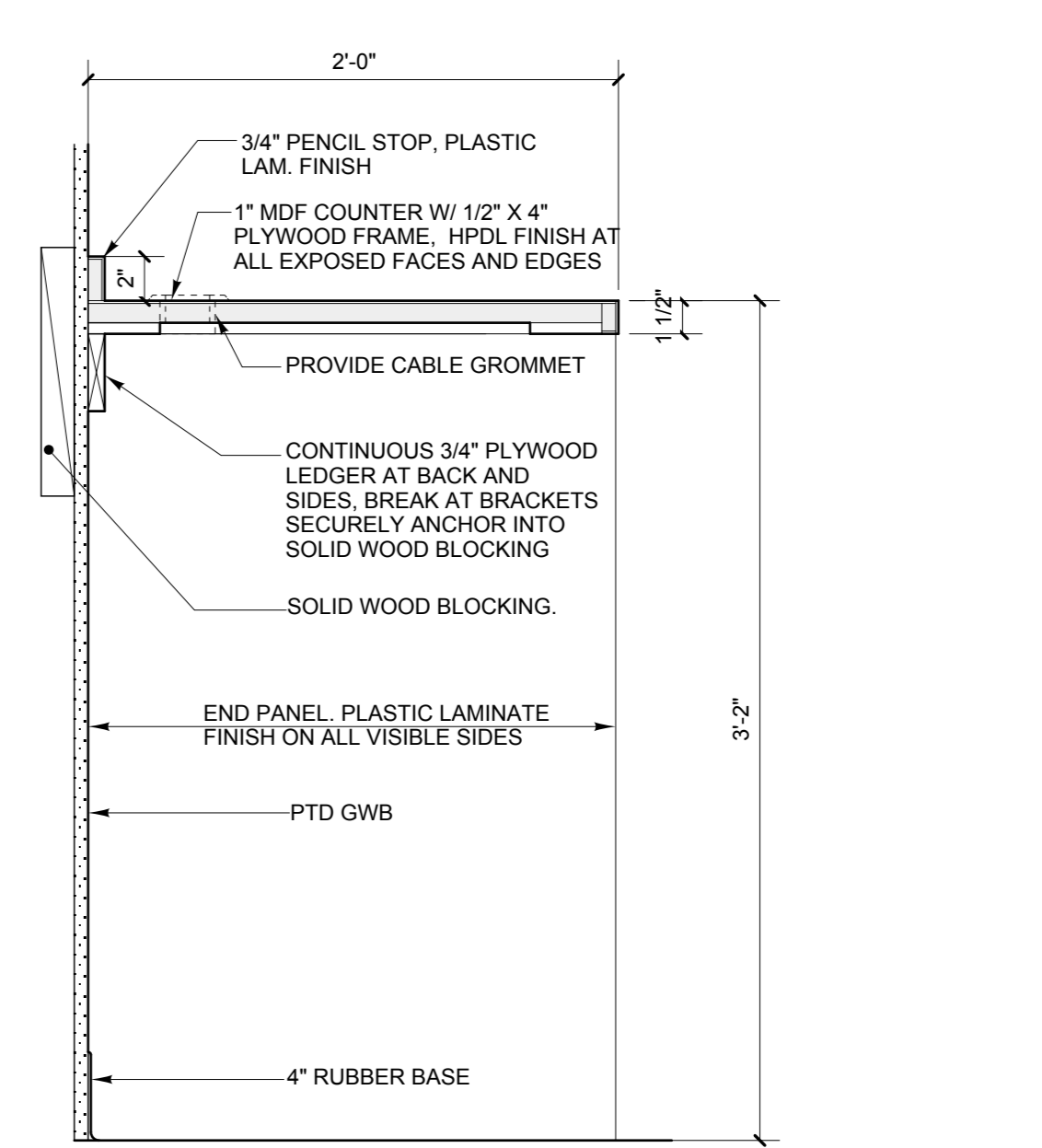

N PRINTER COUNTER DETAIL AT 107
SCALE: 1 1/2" = 1'-0"

Portland
Community
Health Center

180 Park Avenue
Portland, Maine

CONSTRUCTION DOCUMENTS
August 31, 2012

Millwork Details

1 1/2" = 1'-0"

A 204