

**SIEMENS**

**Fire Safety**

**Model PAD-3  
Distributed Power Module NAC Expander  
Installation, Operation, and Maintenance Manual**

Siemens Building Technologies, Inc.  
8 Fernwood Road  
Florham Park, New Jersey 07932

Siemens Building Technologies, Ltd.  
2 Kenview Boulevard  
Brampton, Ontario L6T 5E4 Canada

P/N 315-099082-9



# Table of Contents

	PREFACE .....	ii
1.	DESCRIPTIONS .....	1
1.1	General Design Features .....	1
1.2	Regulatory Standards .....	2
1.3	General Specifications .....	3
2.	INSTALLATION .....	5
2.1	Mounting the Enclosure .....	5
2.2	Control Unit Mounting .....	6
2.3	Wire Routing .....	7
2.4	Terminal Descriptions and Electrical Ratings .....	8
2.5	Wiring The PAD-3 .....	9
2.5.1	AC Wiring .....	10
2.5.2	Battery Connection .....	11
2.5.2.1	Multiple Module Battery Connection .....	12
2.5.3	Style Y (Class B) Input/Output NAC Wiring .....	13
2.5.4	Style Z (Class A) Input/Output NAC Wiring .....	14
2.5.5	Auxiliary Power Supply Output .....	15
2.5.6	Common Trouble Relay .....	15
2.5.7	AC Fail Relay .....	16
2.6	Ground Fault Detection Enable/Disable .....	16
3.	CONNECTION TO CONTROL UNITS .....	17
4.	SAMPLE APPLICATIONS .....	27
4.1	Notification Appliance Power Applications .....	27
4.2	Door Holder Applications .....	32
5.	PROGRAMMING .....	33
5.1	Dip Switch Settings .....	33
5.1.1	Selecting the Input/Output Configuration .....	34
5.1.2	Setting the Auxiliary Output .....	35
5.1.3	Setting the Input's Control of their NACs .....	36
5.1.4	Setting the AC Power Fault Reporting Delay .....	37
5.2	Jumper Settings .....	38
6.	REFERENCE DATA .....	39
6.1	Wire Selection Guides .....	39
6.1.1	Resistance of Solid Copper Wire .....	39
6.2	Battery Size Calculations .....	40
7.	COMPATIBLE DEVICES .....	41
8.	TROUBLESHOOTING .....	41
8.1	LED Indicators .....	41
8.2	Improper Operation .....	41
8.3	Trouble Conditions .....	42
8.4	Fuse Replacement .....	43
9.	BATTERY MAINTENANCE .....	44
10.	GLOSSARY .....	45

## **PREFACE**

Along with the use of this Owner's Manual, the appropriate following standards and the manufacturers' instructions for initiating and signaling devices should be used to install and maintain a functioning Fire Alarm Signaling System.

**NFPA 70**                      National Electrical Code

**NFPA 72**                      National Fire Alarm Code

**NFPA 101**                    Life Safety Code

Other Standards - Contact the authority having jurisdiction for other standards that may apply.

For Publications, contact:

National Fire Protection Association  
Batterymarch Park  
Quincy, MA 02269

# 1. DESCRIPTIONS

The Model PAD-3 from Siemens Building Technologies, Inc. is a notification and auxiliary power expander that provides up to 6 amps of 24 volt DC for powering notification appliances and auxiliary devices. The PAD-3 provides its own AC power connection, battery charging circuit, and battery connections. Used with a fire alarm control unit, this enables you to connect and distribute power to many more devices than your control unit may normally allow.

## 1.1 GENERAL DESIGN FEATURES

### Inputs

The PAD-3 has two optically isolated inputs that provide the connection from the fire alarm control unit notification appliance circuit to the PAD-3. The inputs also provide a connection for returning a trouble condition to the control unit notification appliance circuit.

The fire alarm control unit supervises its notification appliance circuit used for communicating with the PAD-3 the same way it supervises ordinary NACs. The inputs on the PAD-3 monitor the polarity of the voltage coming from the fire alarm control unit's NACs to determine when to operate the notification appliance circuit outputs. The PAD-3 emulates the trouble behavior of a NAC by opening the EOL supervision current for trouble conditions. Note that the PAD-3 will sense the polarity of the fire alarm control unit's NACs to drive the outputs whether or not the supervision connection is intact.

The following situations will open the EOL supervision at the inputs indicating a trouble condition:

- No or Low AC power.
- No and Low battery condition.
- Ground fault to the output wiring.
- Auxiliary Power Supply output over-current condition.
- NAC output open, shorted or over-current condition on outputs associated with its input.

Notes:

If input 1 controls all four outputs, a fault on any output will cause input 1 to indicate trouble. The fault does not affect input 2.

If input 1 controls outputs 1 and 2, and input 2 controls outputs 3 and 4, a fault condition on output 3 or 4 will cause input 2 to indicate trouble. The fault does not affect input 1.

Once the PAD-3's inputs and outputs are activated, the fire alarm control unit will not be able to sense trouble conditions through its notification appliance circuit connected to the PAD-3 input circuits. Use the PAD-3 trouble relay when it is necessary to monitor trouble conditions and active alarm conditions at the same time.

### Notification Appliance Circuit Outputs

The PAD-3 has four dedicated, power-limited, NAC outputs that can be configured as two Style Z (Class A) or four Style Y (Class B) circuits.

The PAD-3 provides three configuration options that will drive outputs as slaves that will follow the input or if the inputs are on constant as ANSI temporal code or Sync strobe/horn operation.

Each of the four outputs is rated at 3 amps, though a total of 6 amps maximum can be drawn from the PAD-3 outputs. The yellow *Output* LEDs (DS1-DS4) will indicate an open, shorted or over-current condition on its associated NAC Output.

Selection of which input controls which output, and which inputs are Style Z (Class A) and Style Y (Class B) is done using the 10 position DIP switch on the printed circuit board. Refer to Section 5 for DIP switch settings.

### **Auxiliary Power Output**

The PAD-3 has a dedicated, power limited, auxiliary output that can be configured in two different ways. The auxiliary output can either be non-resettable (always on), or configured to switch off when the AC power goes off to conserve the battery standby power. When the auxiliary power is configured to switch off, there is a 30-second delay before the auxiliary power is turned off after the AC power goes off. The auxiliary power is for supplementary purposes only if it is configured to switch off when AC is lost.

The Auxiliary Power Output is rated at 3 amps. Only a total of 6 amps maximum can be drawn from the PAD-3 outputs. The yellow *Aux PS* LED (DS5) will indicate an over-current condition on the output.

NOTE: The Auxiliary Power Output may be limited to 1.5 amps in certain circumstances. Please see Section 6.2, Battery Size Calculation for more details.

### **Common Trouble Relay**

The PAD-3 includes a form C trouble relay that will de-energize for the following trouble conditions:

- No or Low AC power (With selectable delay between 60-180 minutes. Refer to Section 5.1.4 for delay time settings).
- No and Low battery condition.
- Ground fault to the output wiring.
- Auxiliary Power Supply output over-current condition.
- NAC output open, shorted and over-current condition.

### **AC Fail Relay**

A normally energized relay will be de-energized after no or low AC power without delay. A Form "A" contact provides a local signaling (audible and visual) of an AC fail at the protected premises.

### **Battery Charging and Supervision**

The PAD-3 provides a battery charging circuit for charging sealed lead-acid batteries. The unit also supervises for no and low battery conditions.

### **Ground Fault Detection**

The PAD-3 monitors for ground faults to the output wiring. When detected, the unit lights the yellow *GRND* LED (DS6) and de-energizes the trouble relay and the input supervision relays.

### **Environmental**

All hardware is suitable for use in an interior or protected location.

### **Power Limiting**

The AC power and battery wiring are not power limited. All other circuits leaving the control unit are power limited, provided the proper installation rules are maintained.

### **Transient Protection**

Transient protection devices are provided where needed to meet the requirements of UL864.

## **1.2 REGULATORY STANDARDS**

The PAD-3 meets the requirements of industry and government regulatory agencies as noted.

### **Federal Communications Commission**

The PAD-3 meets the class A requirements of the Code of Federal Regulations (CFR 47), Part 15, subpart J, for electromagnetic field emissions.

### **Underwriters Laboratories**

The PAD-3 control unit is listed under UL Standard 864 for compliance to NFPA Standard 72 for fire service.

## 1.3 GENERAL SPECIFICATIONS

Operating specifications for the PAD-3 are as follows:

### Environmental

- Operating temperature  
32 - 120°F (0 - 49°C)
- Relative humidity  
Up to 93%RH @ 90°F (32°C) non-condensing
- Installation Environment  
Indoor, dry

### Primary Supply

- Primary Input Voltage: 120 VAC (50/60 Hz) nominal
- Maximum primary input current: 2.5A

### Secondary and Trouble Power Supply

- 24 volt lead-acid battery set
- Maximum Charge Voltage: 27.8 VDC
- Maximum Charge Current: 3.3A
- Maximum Input Current: 6.1A
- Battery capacity: 7 to 15 A.H. (See Section 6.2, Battery Size Calculation, when using batteries over 7 A.H.)

### Input Circuits

- Two Input circuits
- Connected to power limited source
- Supervised
- Voltage Range: 16-33 VDC/VFW
- Maximum Input Current: 7.0mA

### Notification Appliance Circuits

- Operating Voltage Range: Special Application 16-32 VDC  
Refer to Siemens Compatible Notification Appliances (P/N 315-096363) for maximum number per NAC
- Synchronized appliances permitted
- Maximum Alarm Current: 3.0A per circuit (6.0A total for NACs and auxiliary power)
- Four Class B, Style Y circuits or two Class A, Style Z circuits
- Power limited
- Supervised
- Maximum Standby Current: 1.0mA
- Maximum Ripple: 100mVAC
- Maximum Line Resistance: 0.9 ohms @ 3.0 amps, 1.08 ohms @ 2.5 amps, 1.35 ohms @ 2.0 amps, or 1.8 ohms @ 1.5 amps
- Ground fault impedance: 2K ohms (+), 8K ohms (-)

## **Auxiliary Power Output**

- Operating Voltage Range: Special Application 18-28 VDC  
Compatible devices: TRI-B6R (P/N 500-893536), TRI-R (P/N 500-896224)
- Current:
  - 3 amps max (set to shutdown when AC power fault, battery rating up to 7.0 A.H.)
  - 1.5 amps max (set to shutdown when AC power fault, battery rating up to 15 A.H.)
  - 0.17 amps max (set to on when AC power fault, 24 hours standby, battery rating 7.0 A.H.)
  - 0.44 amps max (set to on when AC power fault, 24 hours standby, battery rating 15 A.H.)(Refer to Section 6.2, Battery Size Calculation)
- Power limited
- Supervised for ground fault and short
- Ripple: 0.1 VAC maximum
- Ground fault impedance: 24K ohms (+), 12K ohms (-)  
Note: The auxiliary power is for supplementary purposes only if it is configured to switch off when AC is lost.

## **Common Trouble Relay**

- Contact Rating:  
2.5A, 30 VDC/VAC maximum, resistive
- Form "C" Contact

## **AC Fail Relay**

- Contact Rating:  
2.5A, 30 VDC/VAC maximum, resistive
- Form "A" Contact



## **2. INSTALLATION**

### **CAUTION:**

**It is recommended that the printed circuit boards be removed for any procedure that may cause dust, metal shavings, grease or any such matter that may affect the circuit boards and/or parts.**

**There may be several sources of power into the control unit. Each source must be disconnected prior to installing or connecting or disconnecting wiring.**

**Each output circuit is rated at 3 amps. DO NOT OVERLOAD. Overloading a circuit will cause it to shut down (power limit).**

### **2.1 MOUNTING THE ENCLOSURE**

(For indoor use only in dry environments)

The fire alarm control unit must be mounted in a properly accessible location as required by applicable codes. Any auxiliary battery box or other accessory not connected through a protective device or a circuit designed for remote connection must be within the same room and connected through electrical conduit. Installation is to be done only by qualified personnel who have thoroughly read and understood these instructions.

When mounting the enclosure on interior walls, use appropriate screw anchors in plaster. When mounting on concrete, especially when moisture is expected, first attach a piece of 3/4-inch plywood to the concrete surface. Attach the PAD-3 enclosure to the plywood.

Consult the installation instructions included with the enclosure for proper mounting.

## 2.2 CONTROL UNIT MOUNTING

To install the main board, install 3 screws loosely into the bottom mounting holes or mounting rails. Slide the bottom of the board behind the screws, aligning the screws with the slots in the board. Install a screw in the center position at the top of the board, and two male standoffs in the top left and top right corners of the main board. Tighten all fasteners. Next, install the insulator to the standoffs using the two remaining screws. All mounting hardware is included with the PAD-3 main board. See Figure 2-1 below for details.

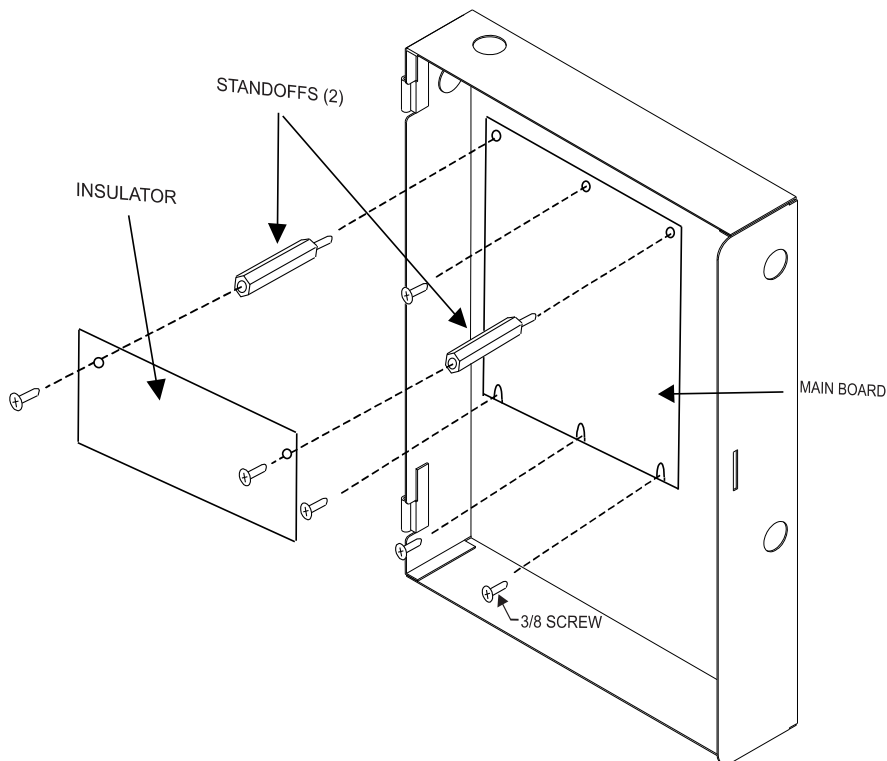

Figure 2-1. Mounting the PAD-3-MB

Before installing the PAD-3, the input must first be wired into the building's main electrical power through the TB1 terminals. See Figure 2-2 on page 8. Shut off the electrical power to the PAD-3, and then complete the general installation of the PAD-3 using the information in this section.

## 2.3 WIRE ROUTING

### Notes:

All high voltage and non-power limited wiring must be kept separate from power limited wiring. A 1/4" separation must be maintained, with high voltage and non-power limited wiring running in separate conduit openings from power wiring.

To avoid induced noise (transfer of electrical energy from one wire to another), keep input wiring isolated from high current output and power-limited wiring. Improper wiring installation may cause improper operation. Avoid pulling one multi-conductor cable for the entire system. Instead, separate high current input/output from low current.

Wiring within the cabinet should be routed around the perimeter of the cabinet. It should not cross the printed circuit board where it could induce noise into the sensitive microelectronics or pick up unwanted RF noise from the switching power supply circuit.

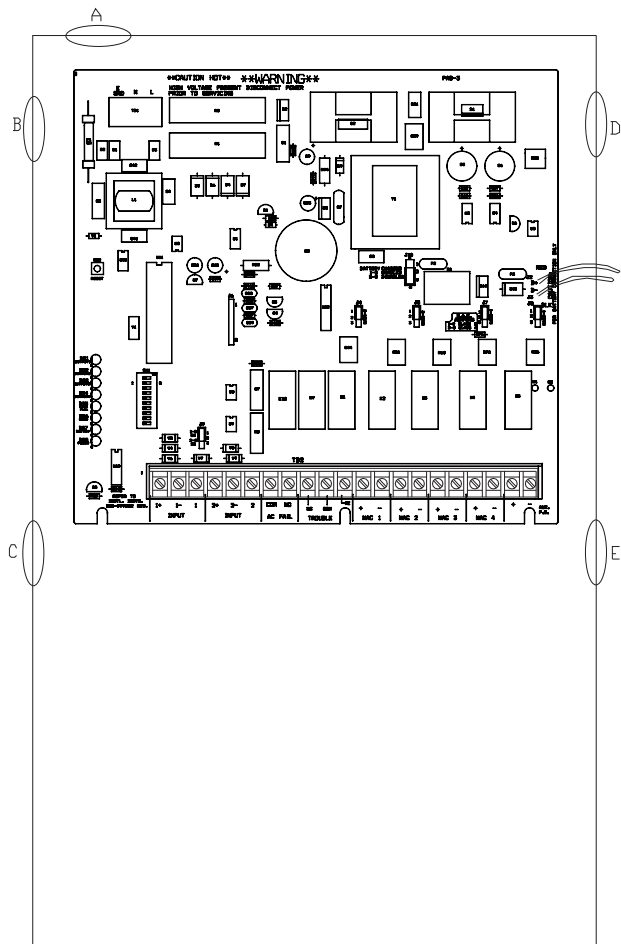

- A. Non-power Limited - High Voltage (AC power) or B
- B. Non-power Limited - High Voltage (AC power) or A
- C. Non-power limited – (Battery wiring, if separate enclosure required)
- D. Power limited (or E)
- E. Power limited (or D)

## 2.4 TERMINAL DESCRIPTIONS AND ELECTRICAL RATINGS

Table 2-1. Terminal Descriptions

Terminal #	Description	Ratings	
<b>TB1</b>			
1	Earth Ground	120 VAC 50/60 Hz, 2.5A max.	
2	AC (white-"neutral")		
3	AC (black - "live")		
<b>TB2</b>			
1	Input 1 (+)	16 – 33 VDC/VFW, 7mA max.	
2	Input 1 (-)		
3	Input 1		
4	Input 2 (+)	16 - 33 VDC/VFW, 7mA max.	
5	Input 2 (-)		
6	Input 2		
7	Normally Open contact	2.5 A @ 30 VDC/VAC, resistive	
8	Common		
9	Normally Open contact	2.5 A @ 30 VDC/VAC, resistive	
10	Common		
11	Normally Closed contact		
12	NAC 1 Output (+)	Special Application	<i>Even though each output is rated for 3 amps, the total current draw from the 4 NAC outputs and the auxiliary power output must not exceed 6 amps.</i>
13	NAC 1 Output (-)	16-32 VDC, 3A max	
14	NAC 2 Output (+)	Special Application	
15	NAC 2 Output (-)	16-32 VDC, 3A max	
16	NAC 3 Output (+)	Special Application	
17	NAC 3 Output (-)	16-32 VDC, 3A max	
18	NAC 4 Output (+)	Special Application	
19	NAC 4 Output (-)	16-32 VDC, 3A max	
20	Auxiliary Power Output (+)	Special Application	
21	Auxiliary Power Output (-)	18-28 VDC, 3A max (Refer to Section 1.3 General Specifications)	

## 2.5 WIRING THE PAD-3

Figure 2-2 shows the general layout of the PAD-3 PC board. This section also provides specific wiring details for accessories. Consult your control unit manual for specific wiring information on the control unit being used. If you are using a Siemens control unit, see Section 3 for connections.

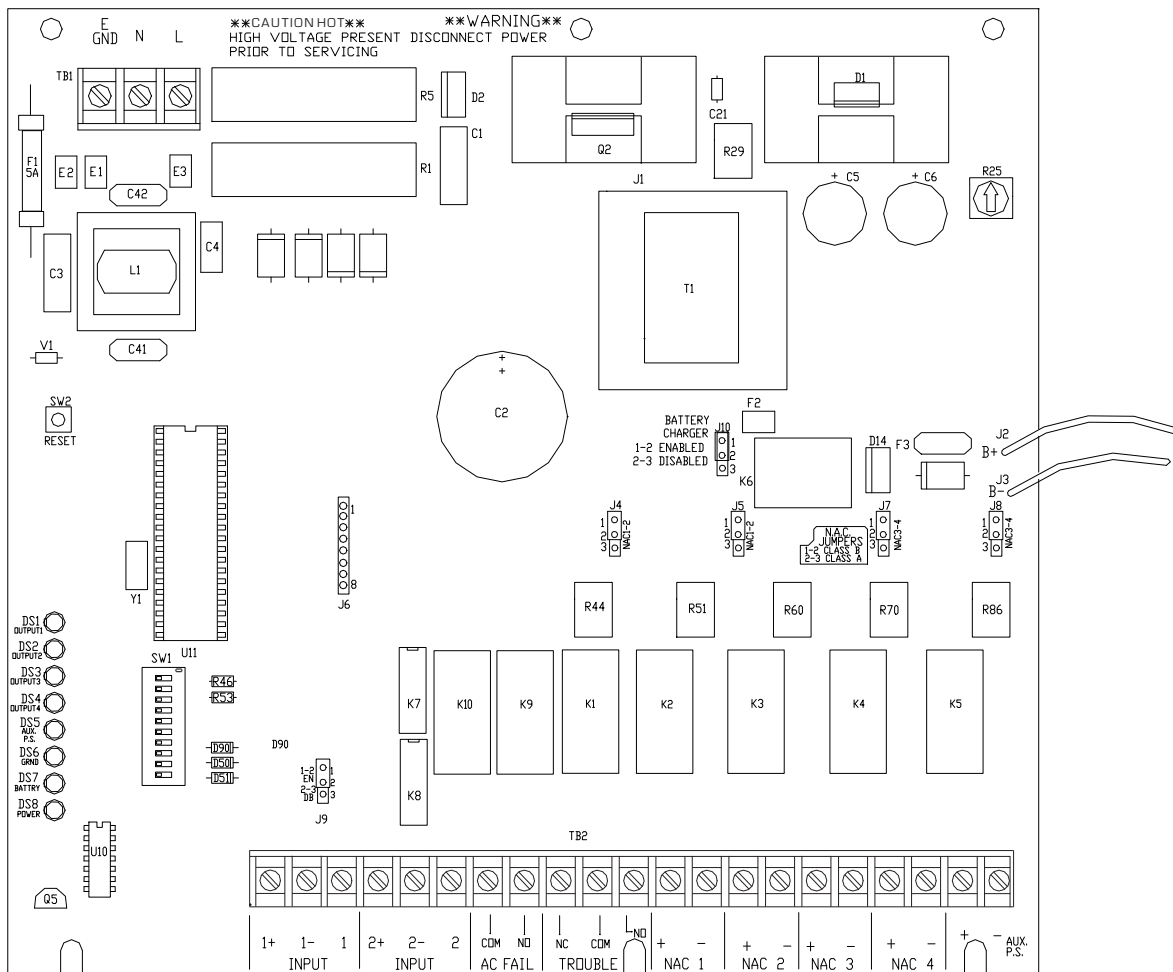

Figure 2-2. PAD-3 PC Board Layout

## 2.5.1 AC Wiring

120 VAC 60Hz, 2.5A MAX.  
SUPERVISED, NON-POWER LIMITED

Note: Branch current  
must be protected by  
a 15A overcurrent  
device.

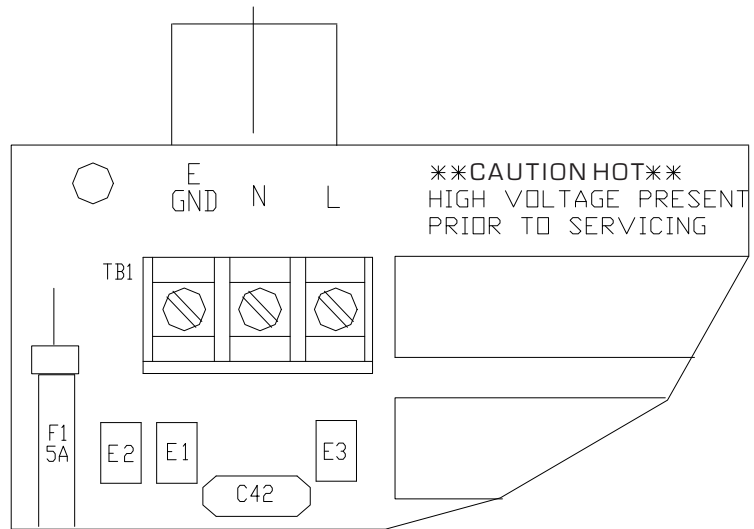

Figure 2-3. AC Wiring

## 2.5.2 Battery Connection

The PAD-3 requires a 24V sealed lead-acid battery set. The battery capacity can be from 7 to 15A.H. For battery sets larger than 7A.H., an enclosure with System 3 rails or a separate battery enclosure is required.

The following steps and diagram explain how to connect the Siemens BT-33, 7A.H. battery set.

1. Connect black wire to the negative (-) side of battery #2.
2. Connect jumper wire from the positive (+) side of battery #2 to the negative side of battery #1.
3. Connect red wire to the positive (+) side of battery #1.

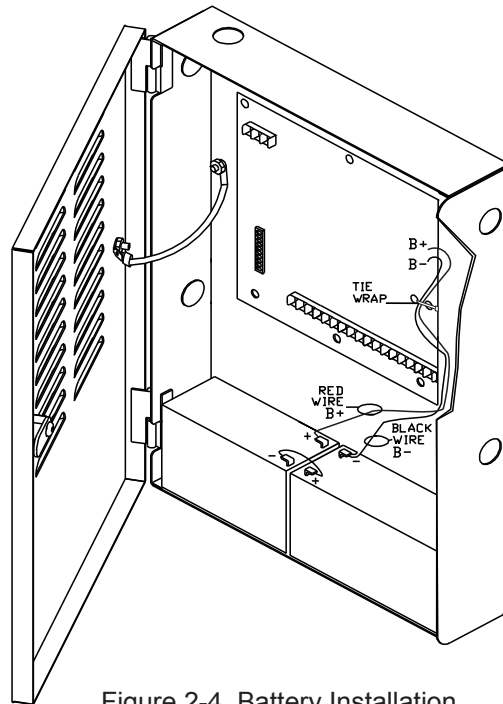

Figure 2-4. Battery Installation

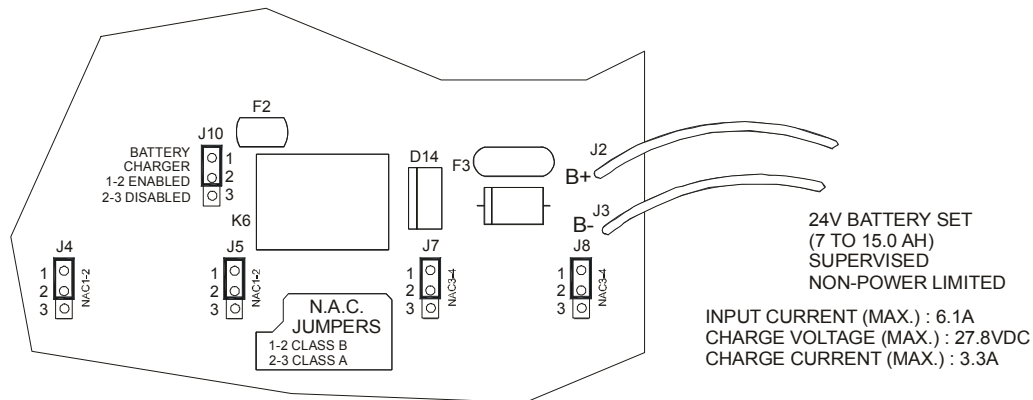

Figure 2-5. Battery Wiring

## 2.5.2.1 Multiple Module Battery Connection

For applications where multiple PAD-3 boards are mounted in an enclosure with System 3 rails, it may be possible to connect two boards to a single battery set. When using a single battery set for two boards, the following rules must be followed:

- a) Both PAD-3 boards must be located within the same enclosure and mounted adjacent to each other.
- b) The combined battery A.H. rating required for both boards does not exceed 15 A.H.
- c) The alarm current must never exceed 6.14A singularly or with 2 PAD-3s combined.
- d) One of the PAD-3 boards must have its charging circuit disabled.
- e) The PAD-3 with the active charger is limited to 1.5 amps of auxiliary DC power at terminals 18 and 19.
- f) Two (2) battery connection splitters (part number 230-299203) are used on the battery set for proper connection.

The following steps and diagrams explain how to connect two PAD-3 boards to a single battery set.

1. Install a battery connection splitter (see Figure 2-6) to the positive and negative terminals on the battery set. If the battery set contains two 12-volt batteries to be wired in series, install one splitter on the positive terminal of battery #1 and the other to the negative terminal of the battery #2.
2. Connect the black wires from both PAD-3 boards to the splitter on the negative terminal of battery #2.
3. If the battery set contains two 12-volt batteries, connect the jumper wire from the remaining single positive terminal of battery #2 to the negative terminal on battery #1.
4. Connect the red wires from both PAD-3 boards to the splitter on the positive terminal of battery #1. See Figure 2-7.

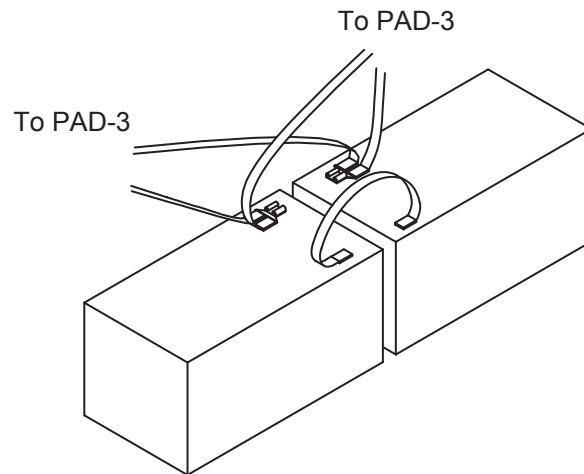
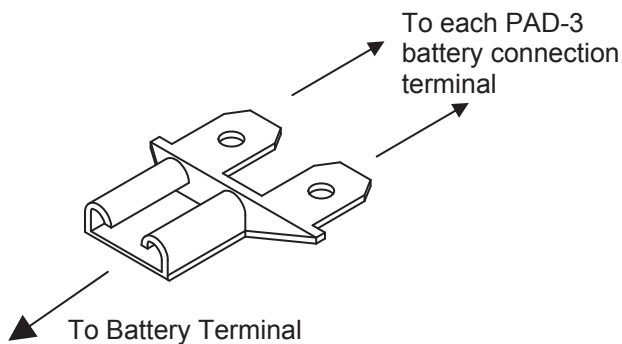

5. Disable the battery charger on one of the units. See Section 5.2 for directions.

Figure 2-6. Battery connection splitter

Figure 2-7. Dual module battery connection



## 2.5.3 Style Y (Class B) Input/Output NAC Wiring

Figure 2-8 shows how to wire for Style Y (Class B) input and output supervision. Use in/out wiring methods for proper supervision.

### Style Y (Class B) Output Notification Circuits

Figure 2-8 shows four, 1.5 amp devices wired as Style Y (Class B) circuits.

Place a 24K ohm EOL resistor (provided) at the end of each loop to enable notification output supervision when using all outputs as Style Y (Class B) notification circuits. The 24K EOLs must be wired to the terminals whether or not you are using all output terminals.

### Style Y (Class B) Supervised Input Circuits

Figure 2-8 shows Style Y (Class B) supervised wiring from a fire alarm control unit to the PAD-3 board. Use the control panel's EOL resistor installed as shown to enable notification input supervision.

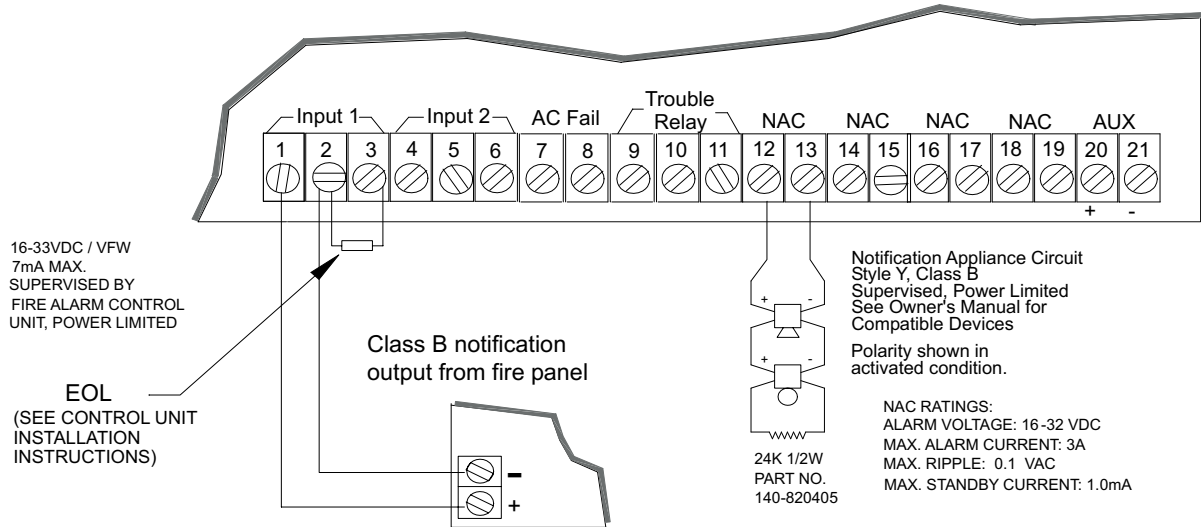

Figure 2-8. Style Y (Class B) Supervised Input/Output Connections

## 2.5.4 Style Z (Class A) Input/Output NAC Wiring

Figure 2-9 shows how to wire for Style Z (Class A) input and output supervision. Use in/out wiring methods for proper supervision.

### Style Z (Class A) Output Notification Circuits

The configuration shown in Figure 2-9 shows two, 3-amp devices wired as Style Z (Class A) circuits. When you are using the outputs as Style Z (Class A) circuits, loop the wiring back to the corresponding circuit pair. For Style Z (Class A) wiring, no external EOL is necessary since it is built into the board.

### Style Z (Class A) Supervised Input Circuits

The configuration shown in Figure 2-9 shows Style Z (Class A) supervised wiring from a fire alarm control unit to the PAD-3 board. Pay close attention to the polarities when wiring the unit and follow these requirements:

When wiring to terminal 2 and 5 on TB2, you must use two separate wires. Do not loop a single wire or twist two conductor wires together.

Do not use notification appliances on Style Z (Class A) circuits connected for input. The PAD-3 will detect voltage across the input circuits, but is not designed to pass the added current load from notification appliances.

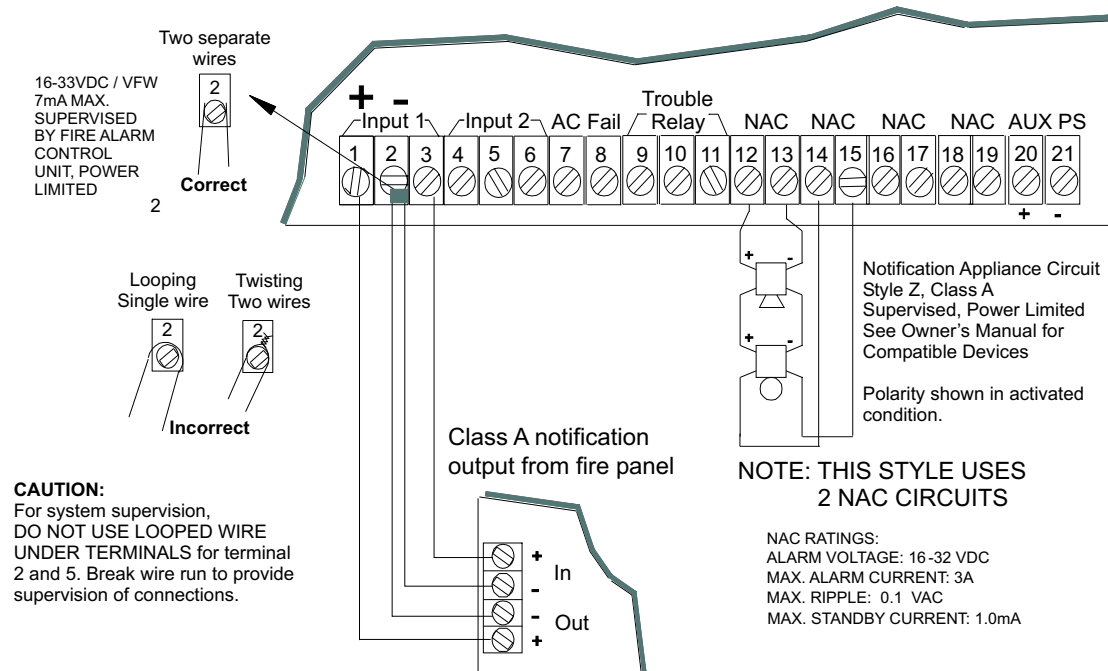
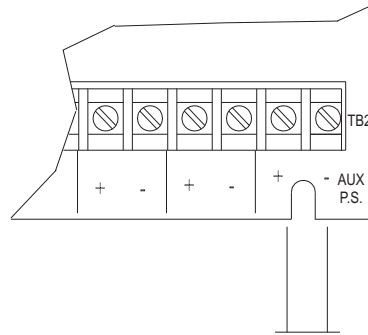

Figure 2-9 Style Z (Class A) Supervised Input/Output Connections

## 2.5.5 Auxiliary Power Supply Output

The auxiliary power supply output provides a 24VDC power source. It is unsupervised and power limited. For applications where the battery charger circuit charges batteries of 7.0 A.H. or less, or if the battery charger is disabled, this output is limited to 3.0 amps maximum. For batteries between 15 A.H. and 7.0 A.H., this output is limited to 1.5 amps maximum.



AUXILIARY POWER OUTPUT  
3A MAX., 18-28 VDC  
(REFER TO SECTION 1.3 GENERAL SPECIFICATIONS)  
UNSUPERVISED, POWER LIMITED

Figure 2-10. Auxiliary Power Supply Output Connection

## 2.5.6 Common Trouble Relay

The PAD-3 board has a Form C trouble relay built into terminals 9-11 of TB2. The trouble relay will de-energize under a trouble condition.

A typical application of the trouble relay is to connect the PAD-3 normally closed (N.C.) contacts in series with an EOL of a spare IDC or NAC or monitor input from a fire alarm control unit. This will cause a trouble on the fire alarm control unit when the PAD-3 opens its trouble contacts.

The common trouble relay will be de-energized after selectable delay (60-180 minutes, refer to Section 5.1.4) if AC is low or lost.

Note: The N.C. contact is the relay contact that is closed when the PAD-3 has power and there are no trouble conditions.

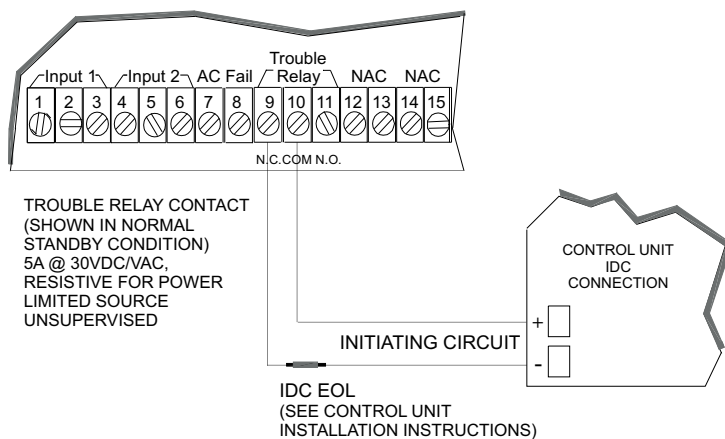

Figure 2-11. Trouble Relay Connection Example

## 2.5.7 AC Fail Relay

AC Fail Relay provides a normally open (N.O.) Form "A" contact which will be de-energized without delay if AC is low or lost. It provides a local signal (audible and visual) of AC fail at the protected premises but will not cause the DACT to signal.

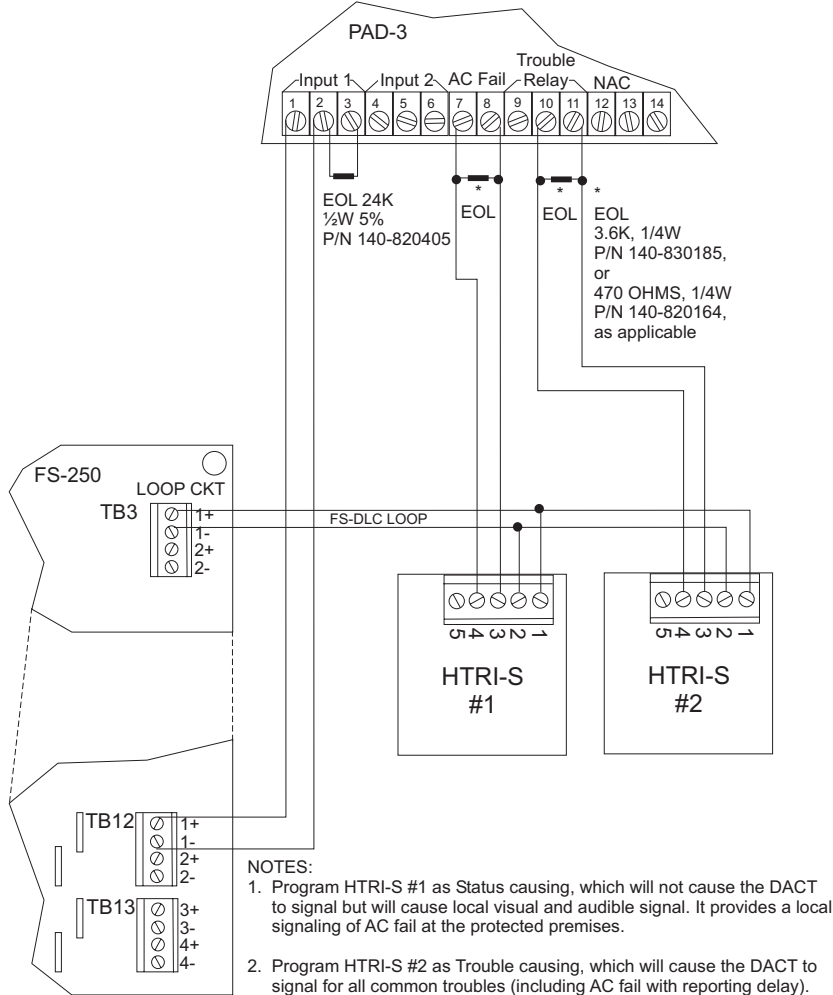

Figure 2-12. AC Fail Relay Connection Example

## 2.6 Ground Fault Detection Enable/Disable

For some applications (when used with RSA-Series annunciators, for instance), the PAD-3 is used to provide power to an auxiliary device which gets a control signal from a fire alarm panel. The ground fault reference for the PAD-3 may be different than the reference used by the fire alarm panel, resulting in a ground fault trouble at the panel even when none exists. To remedy this condition, the PAD-3 can have its ground fault detection circuit disabled. Once disabled, the fire alarm panel's ground fault detection circuitry will detect any ground fault in the system. See Section 5-2 for correct positioning of this jumper, and see Figure 2-2 for the location of this jumper.

# 3. CONNECTION TO CONTROL UNITS

The drawings in this section show you how to connect the PAD-3 to compatible Siemens control units. See control unit owners manual for more information.

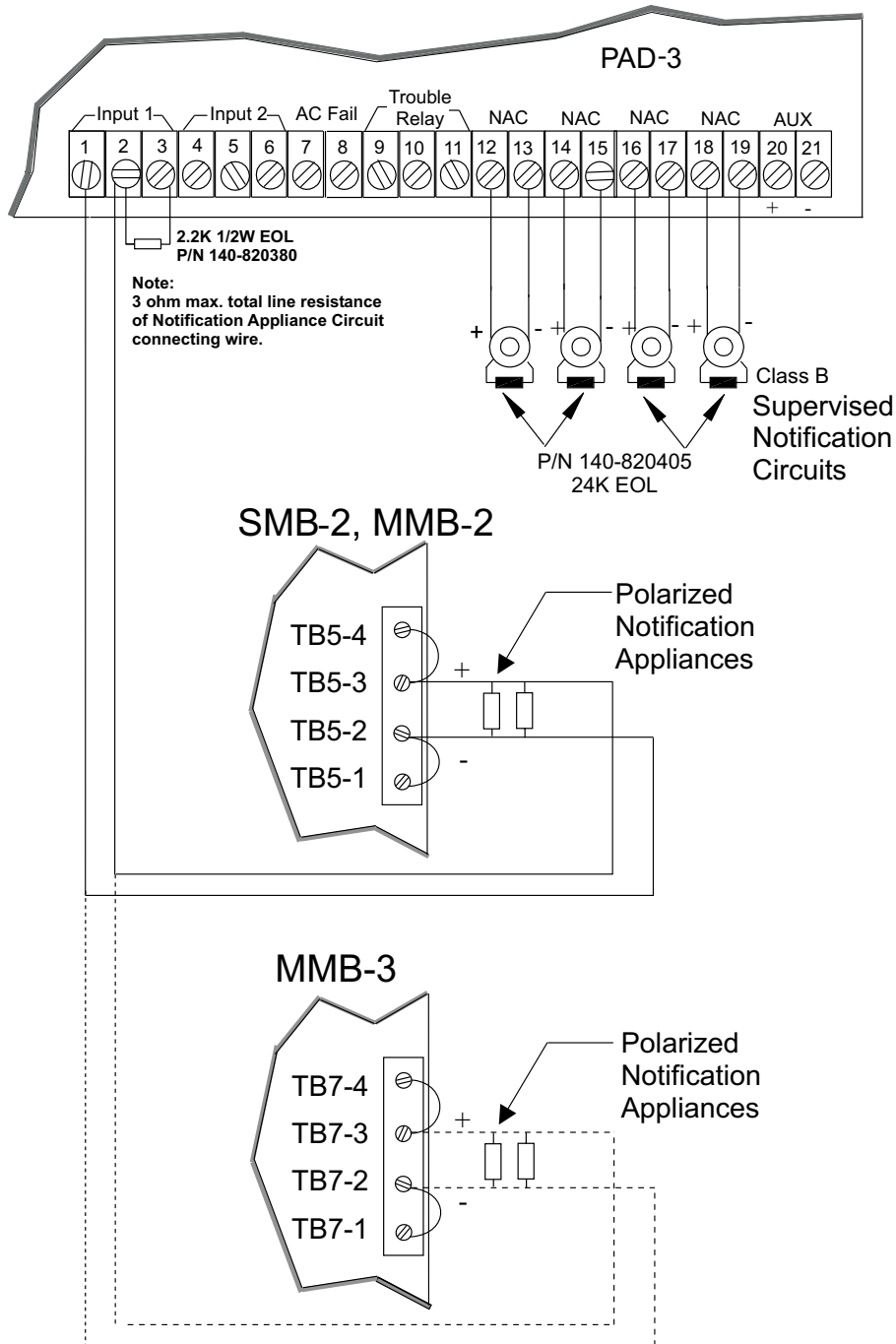

Figure 3-1. Connection to MXL, MXL-IQ

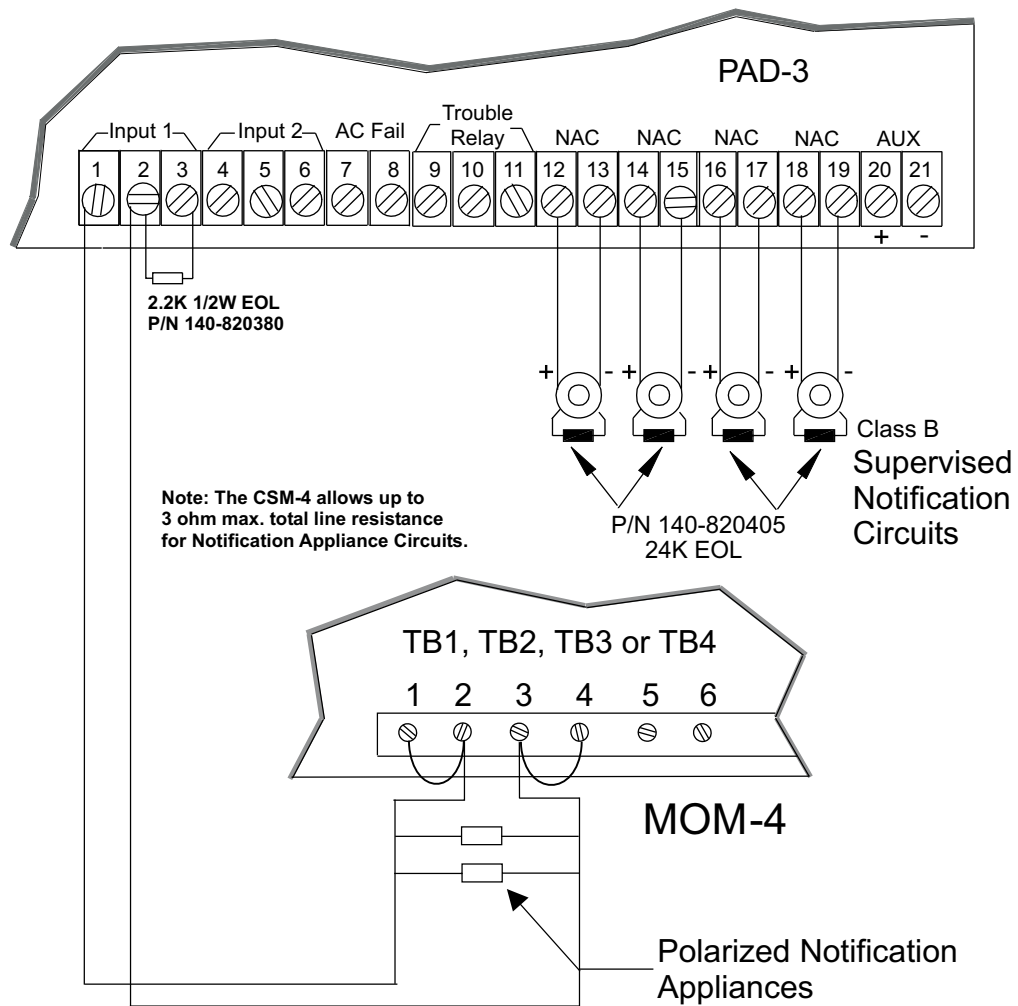

Figure 3-2. Connection to CSM-4

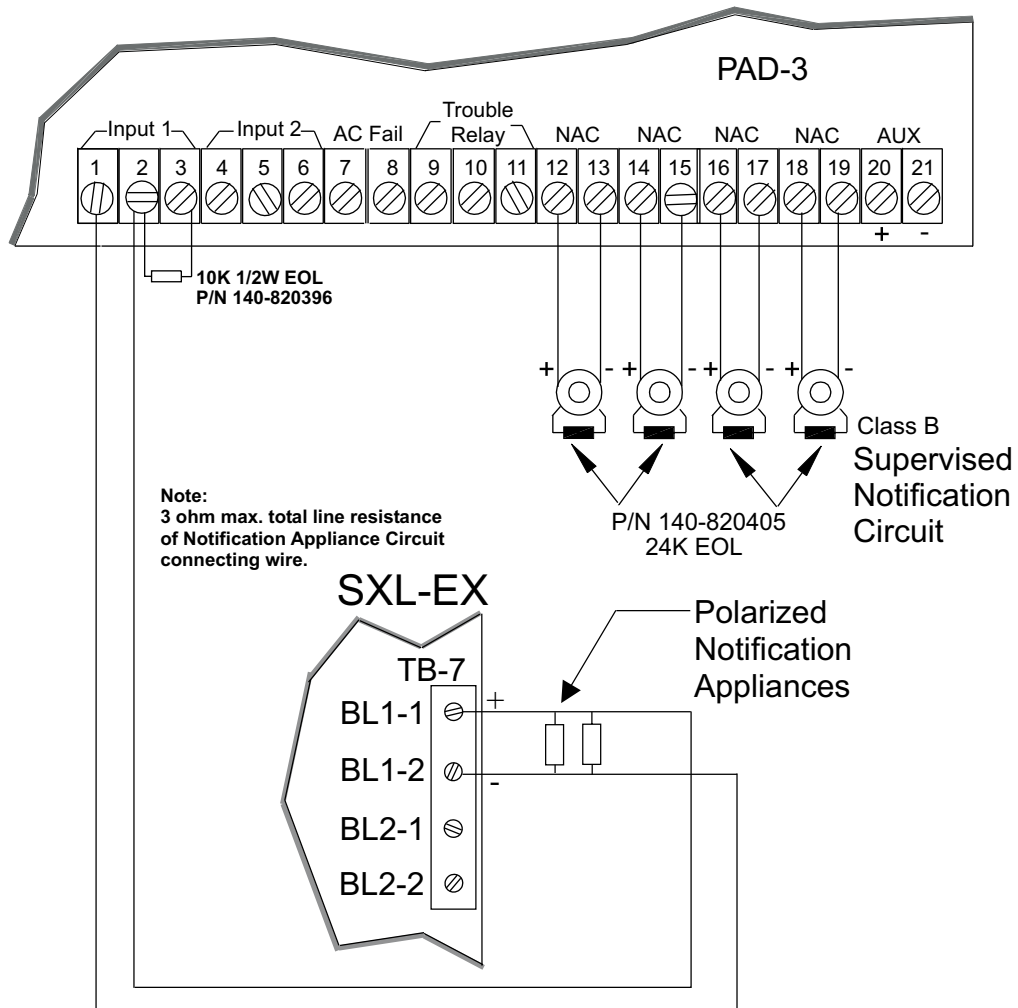

Figure 3-3. Connection to SXL-EX

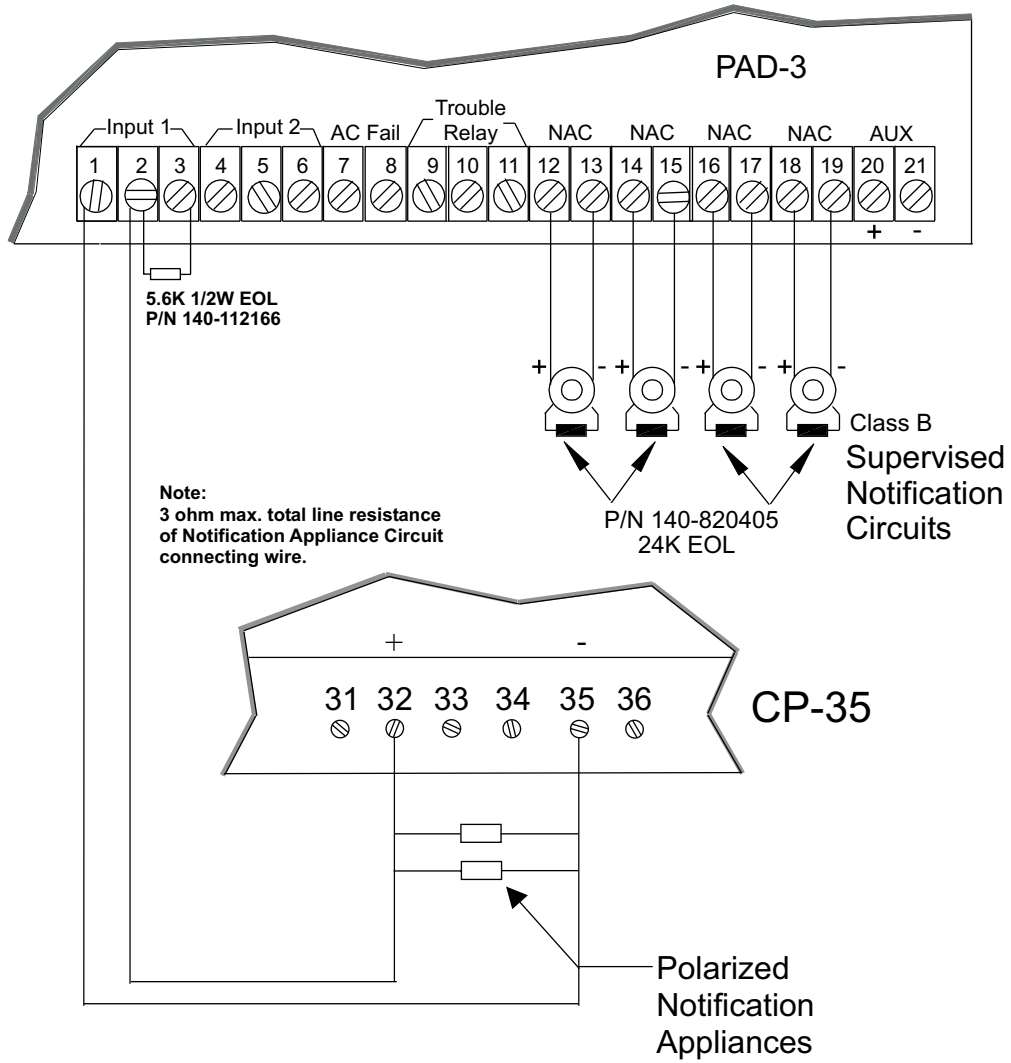

Figure 3-4. Connection to CP-35



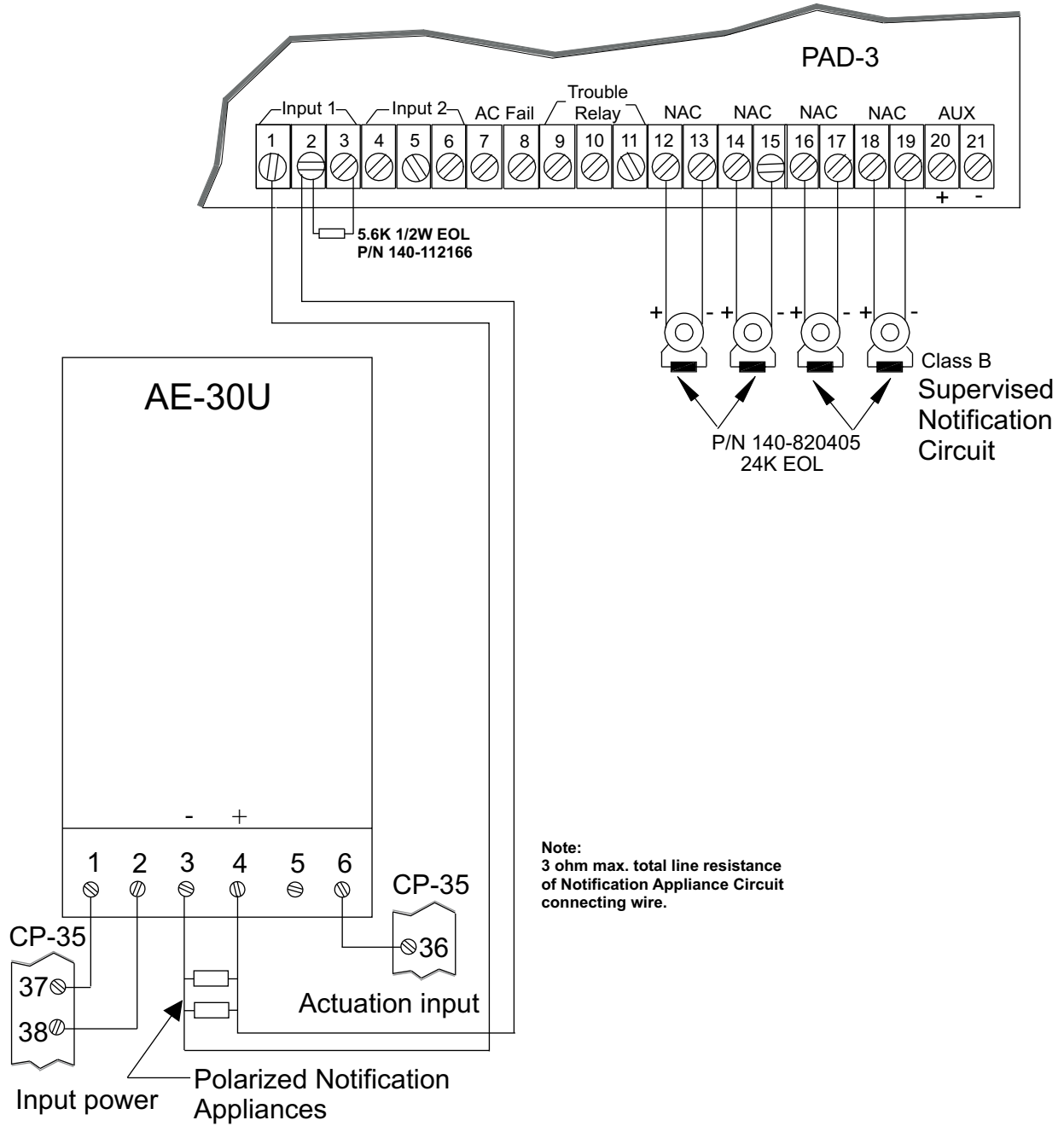

Figure 3-5. Connection to AE-30U

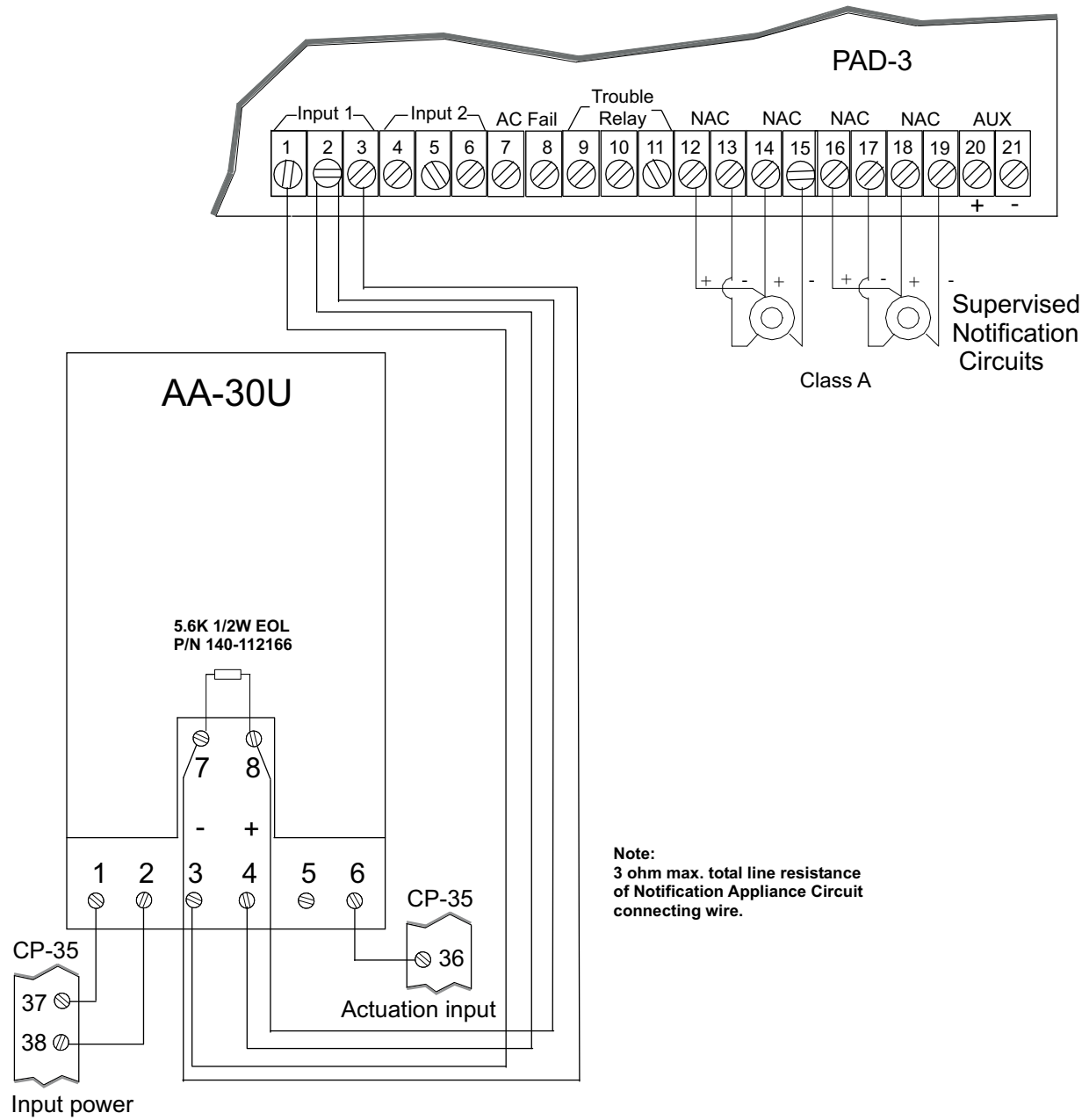

Figure 3-6. Connection to AA-30U

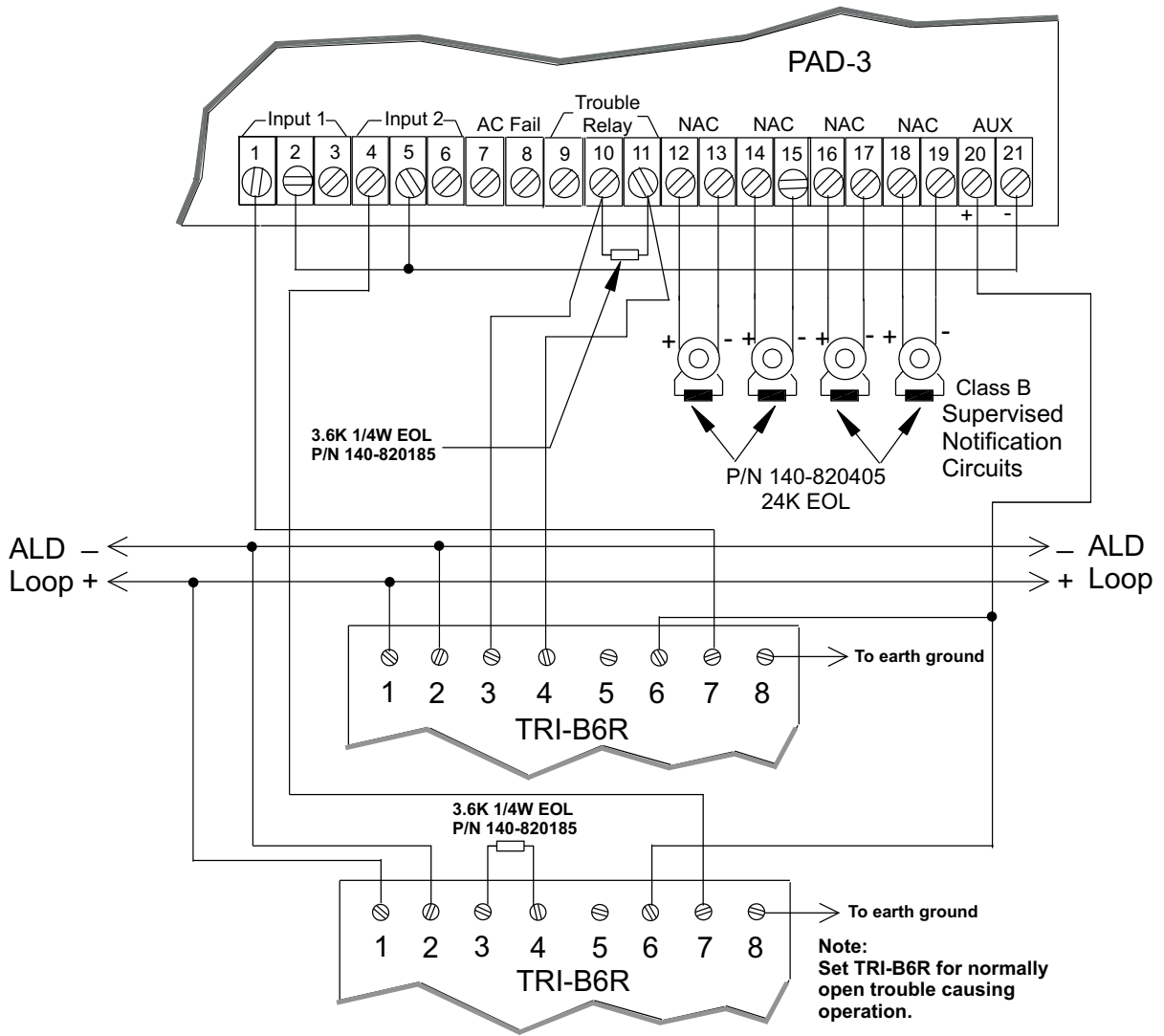

Figure 3-7. Connection to TRI-B6R

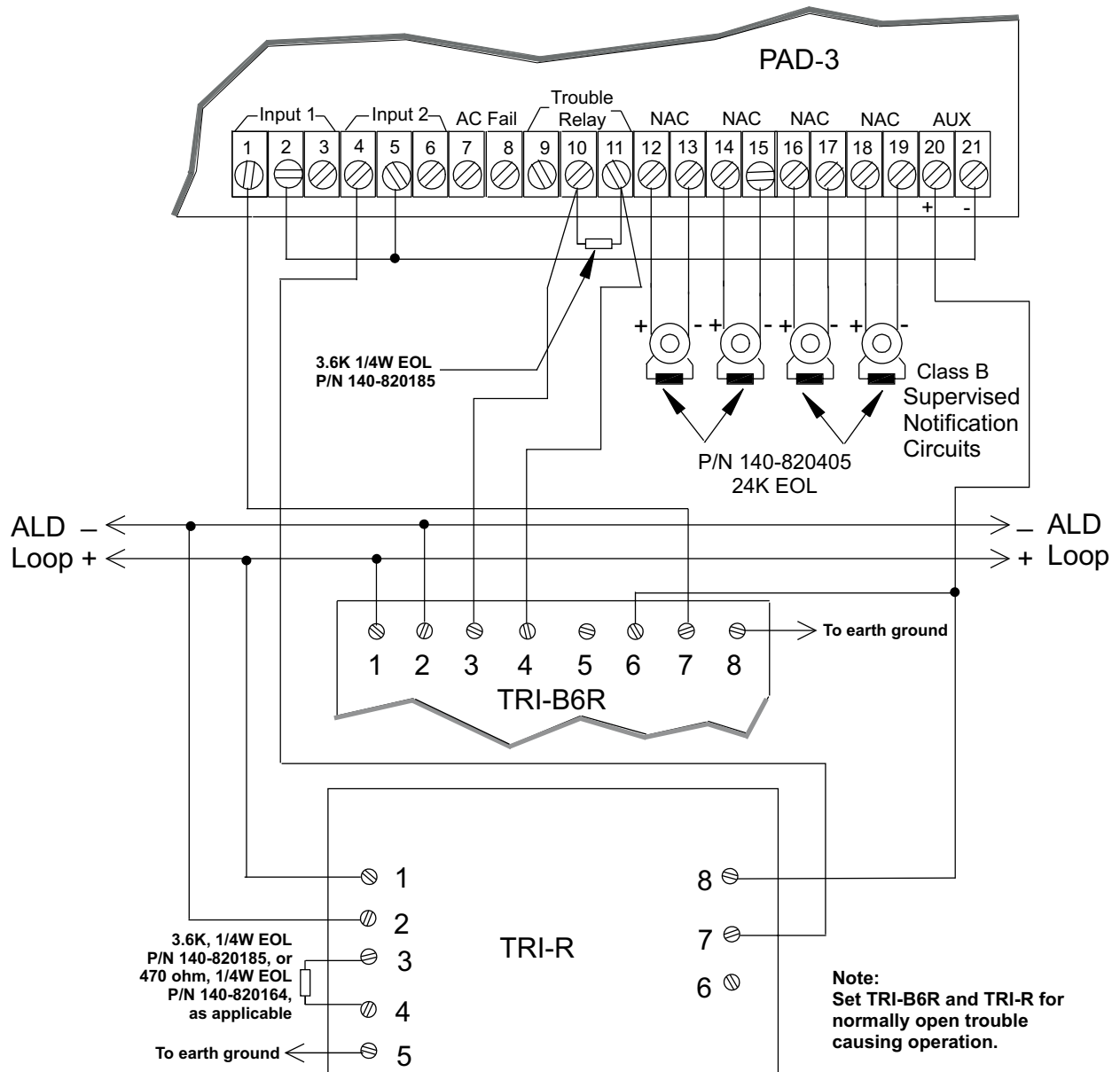

Figure 3-8. Connection to TRI-B6R and TRI-R

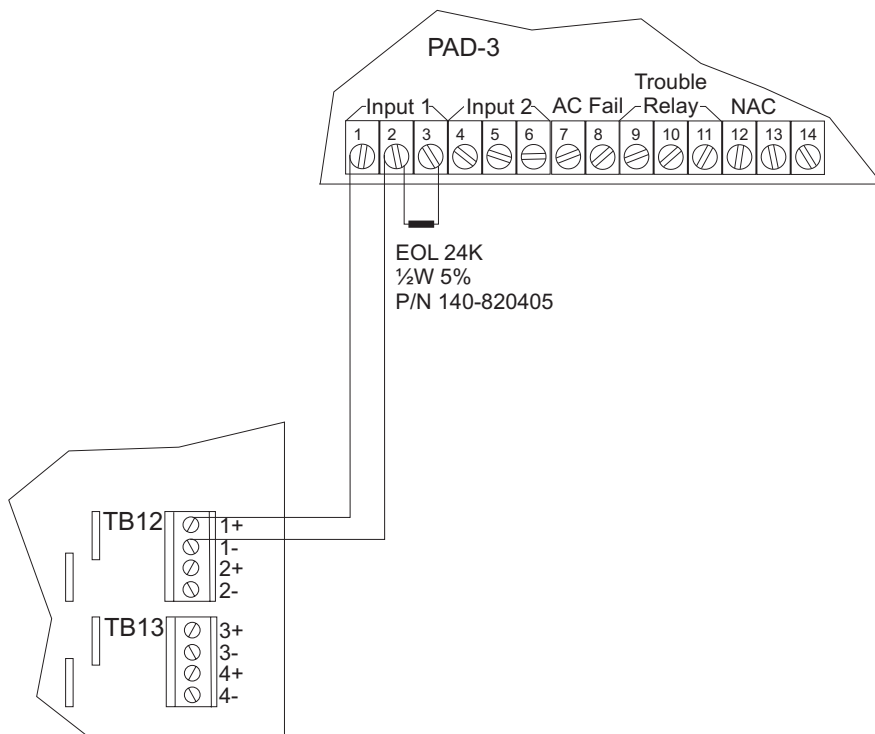
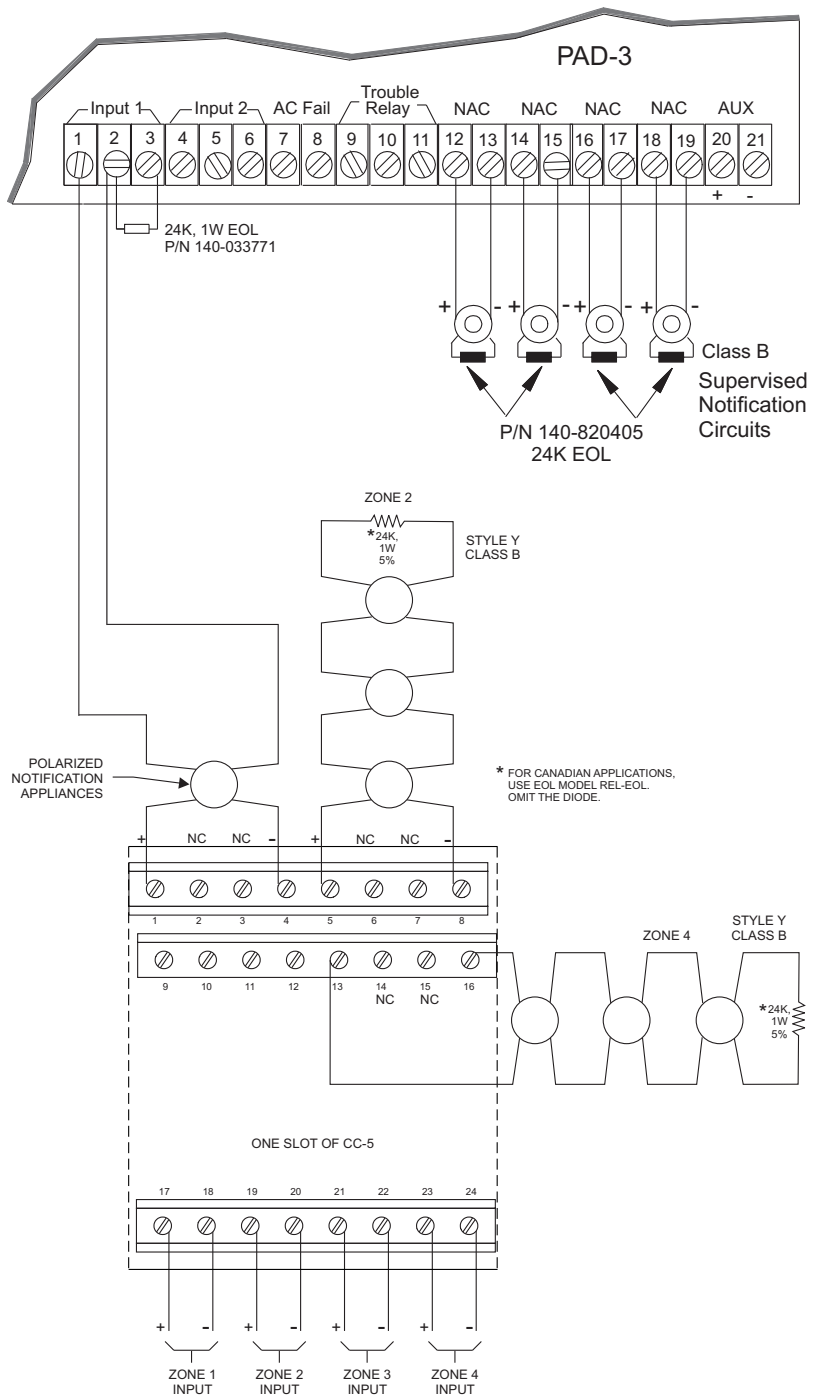

Figure 3-9. Connection to FS-250



**NOTES:**

1. All wiring must be in accordance with Article 760 of NEC or local building codes. Wiring for each zone can either be Class A or Class B.
2. All output circuits are power limited to NFPA 70 per NEC 760.
3. Electrical Ratings:  
Output Zone Supervisory:  
4mA max @ 24VDC  
Output Zone Alarm:  
4A max @ 24VDC
4. EOL resistor, 24K ohms, 1 watt, 5%, P/N 140-033771.
5. Polarity shown in active state.
6. Maximum line resistance is dependent upon the maximum current draw of connected notification appliances when activated. The field wiring resistance cannot exceed the maximum line resistance specified for any given NAC current draw (See Table below).
7. ZIC output must be configured as NAC, NAC-Coded or Sync Strobe only. All other usages are not applicable.
8. Refer to the Zeus Quick Start Manual (P/N 315-033875) and ZIC-4A Installation Instructions (P/N 315-033050) for additional information.

Current Draw	Max Line Resistance
4.0A	0.8 ohms
3.5A	1.0 ohms
3.0A	1.2 ohms
2.5A	1.5 ohms
2.0A	2.0 ohms
1.5A	2.7 ohms
1.0A	4.2 ohms
0.5A	8.7 ohms

Figure 3-10. Connection to ZIC-4A (FireFinder-XLS)

# 4. SAMPLE APPLICATIONS

The drawings in this section show various configurations, including daisy-chaining.

## 4.1 Notification Appliance Power Applications

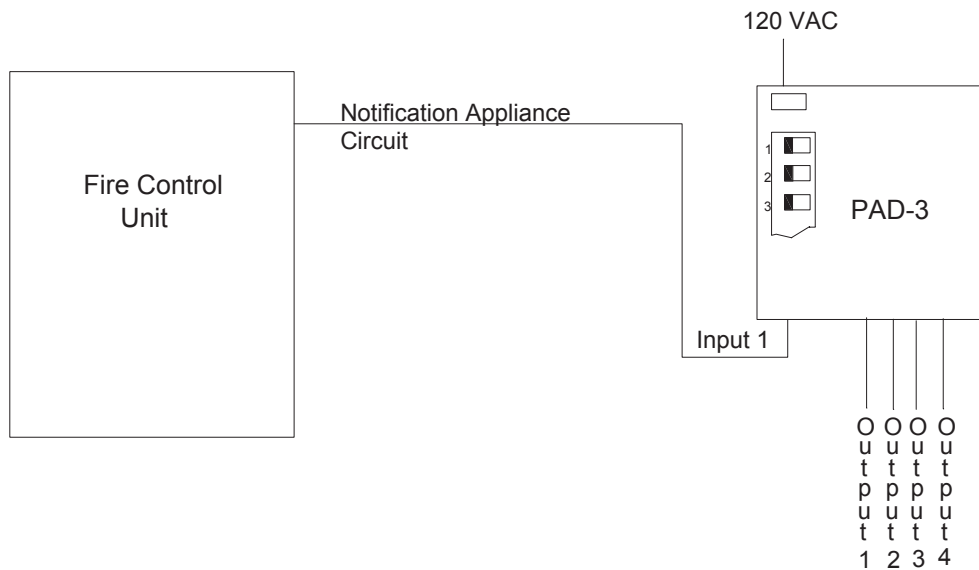

Figure 4-1. Input 1 activates All Four Outputs and Input 2 not used

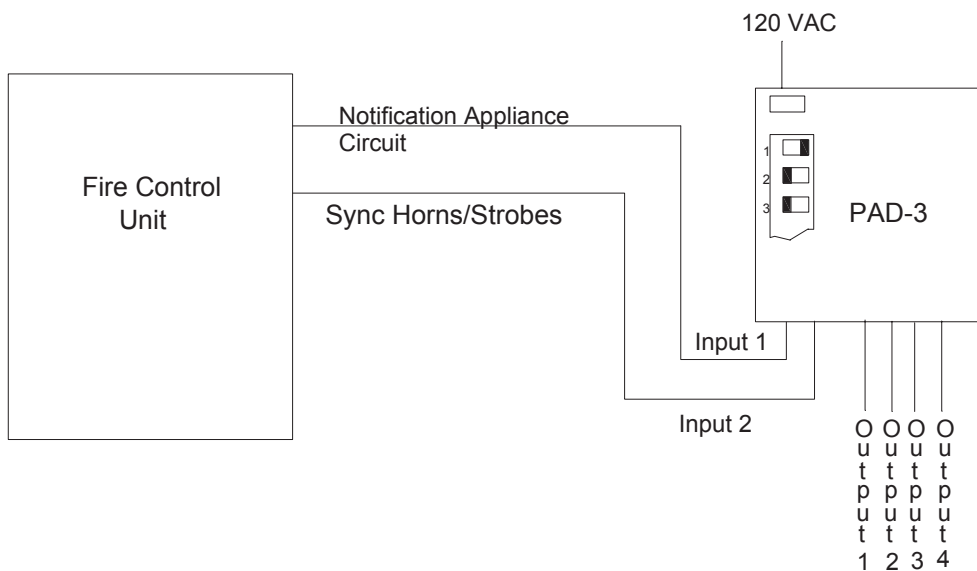

Figure 4-2. Input 1 activates All Four Outputs and Input 2 used to silence Sync Horns

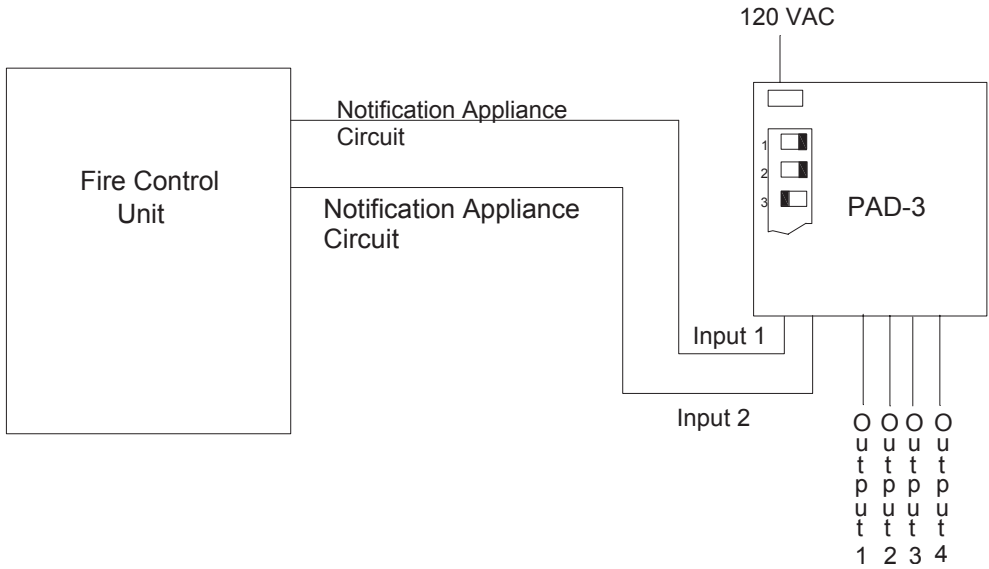
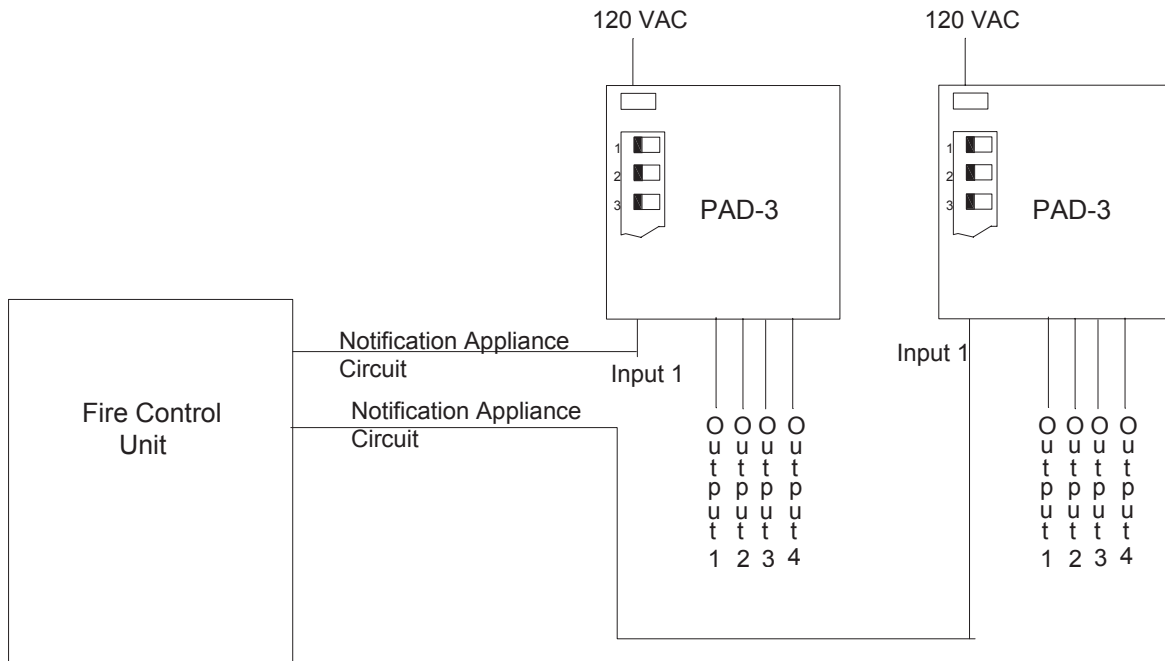

Figure 4-3. Input 1 activates Outputs 1 & 2 and Input 2 activates Outputs 3 & 4



NOTE: Only the appliances connected to the same PAD-3 will operate synchronously when the output circuits of the PAD-3 are set to synchronization mode. The appliances connected to a different PAD-3 will not operate synchronously.

Figure 4-4. One Control Panel activating two PAD-3s



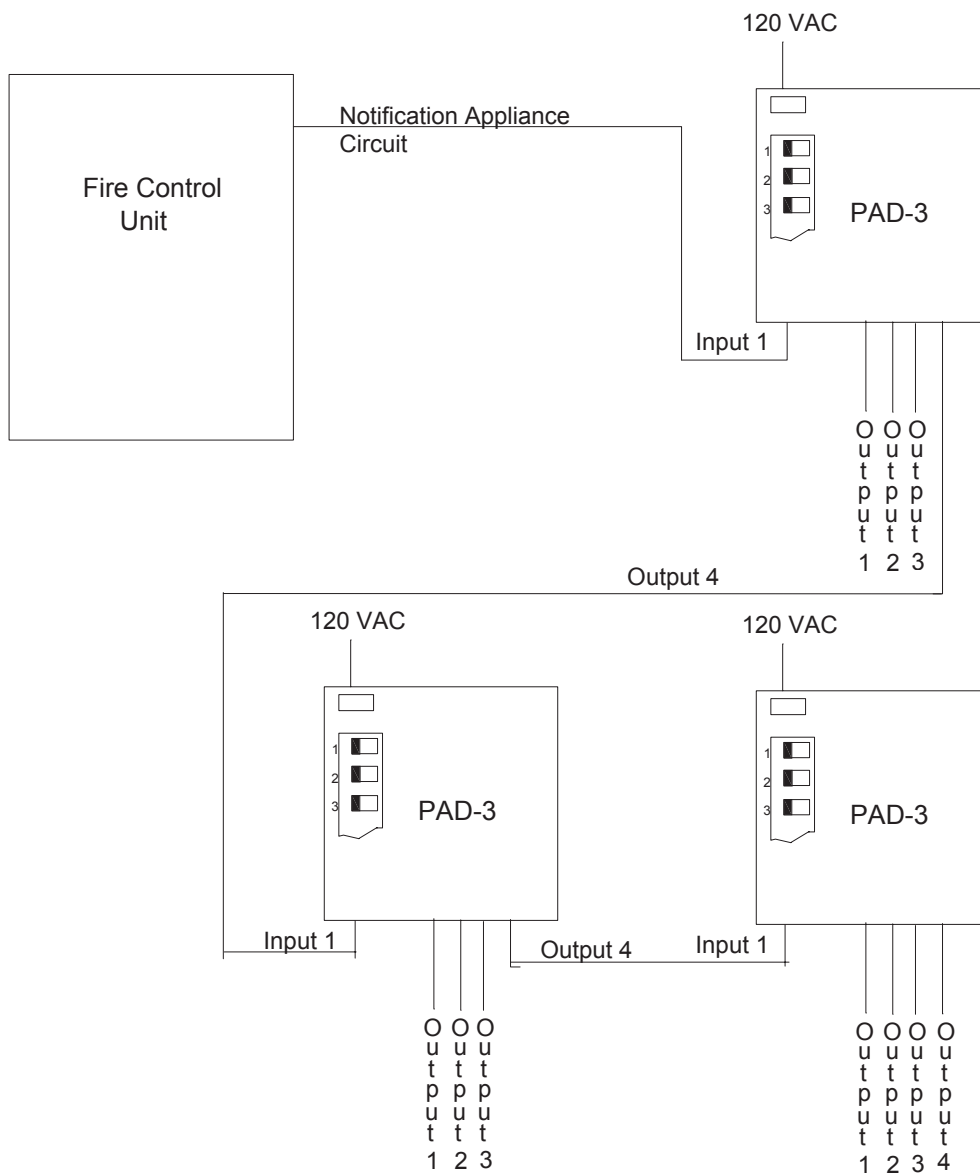
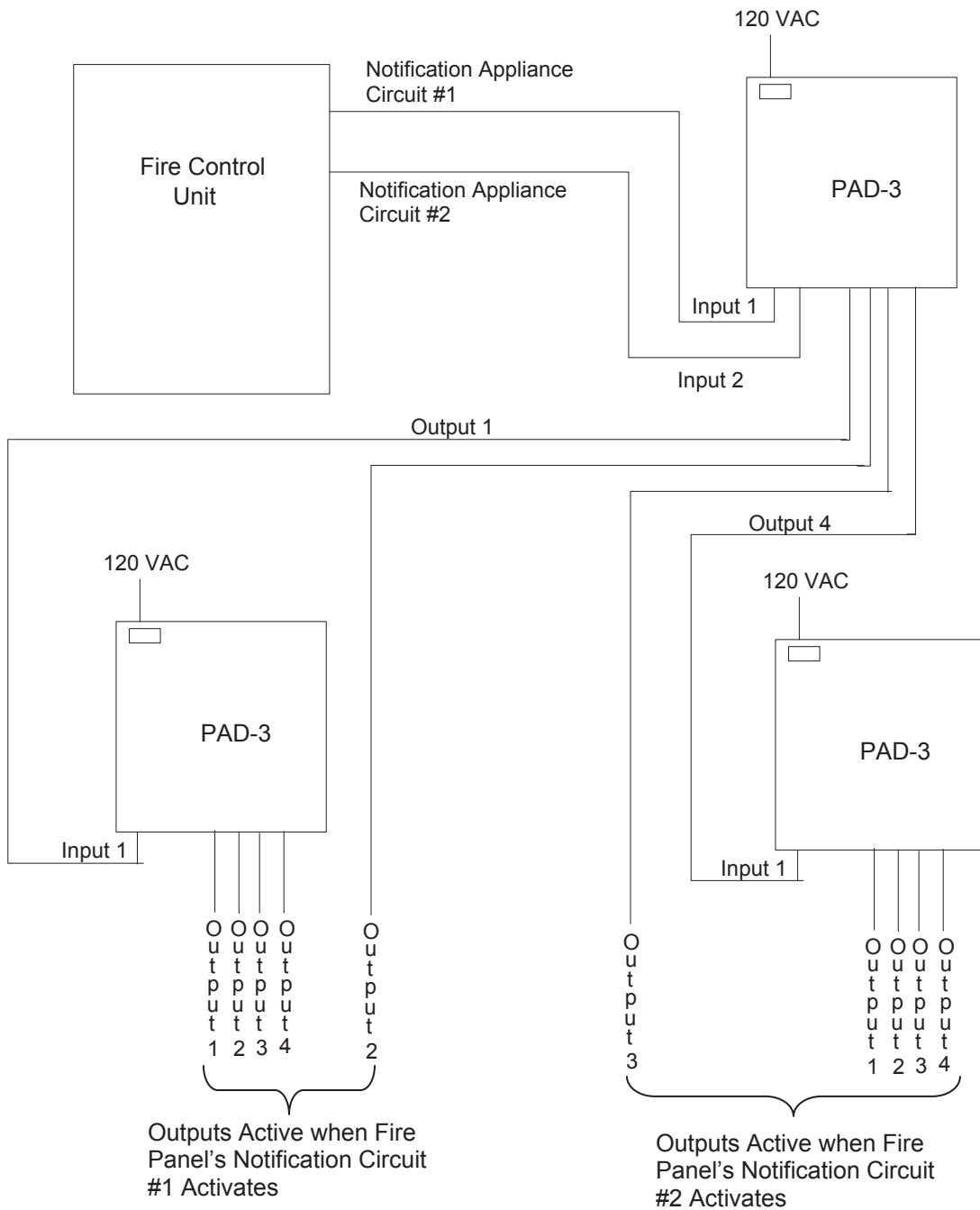

Figure 4-5. One Control Panel activating three PAD-3s



NOTE: Only the appliances connected to the same PAD-3 will operate synchronously when the output circuits of the PAD-3 are set to synchronization mode. The appliances connected to a different PAD-3 will not operate synchronously.

Figure 4-6. Each control signal circuit activates five output circuits

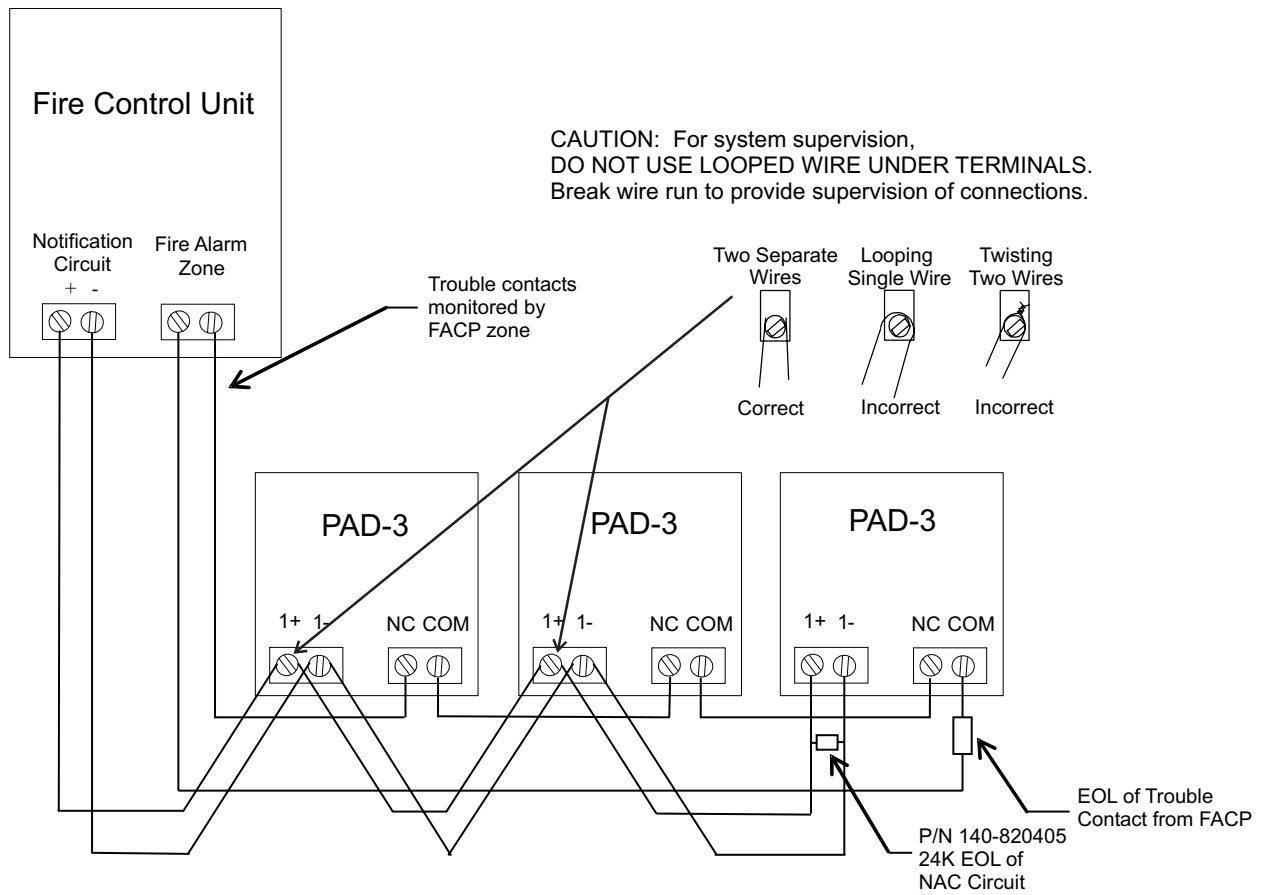

Figure 4-7. Multiple PAD-3s activated by a single notification circuit

## 4.2 Door Holder Applications

In a typical door holder application, the door holder power must be released to close all fire doors under the following conditions:

Any active alarm condition.

AC power is no longer present (to conserve backup battery power).

To close the fire doors in these situations, wire a normally closed relay contact from the fire alarm control unit in series with the auxiliary power to the door holders.

The circuit shown in Figure 4-8 will provide up to 3 amps of door holder current. The power in this example is released when AC power is off for 30 seconds or more, or when the relay from the fire alarm control unit opens. See Section 1.1 for a description of the auxiliary power options, and Section 5.1.2 for information on choosing the options.

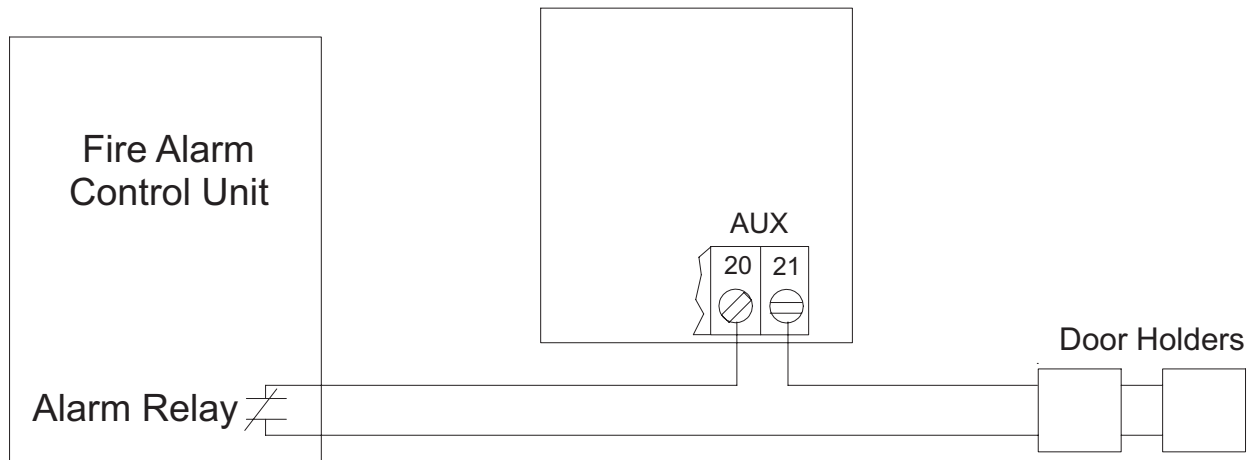

Figure 4-8. Door Holder Wiring Example

# 5. PROGRAMMING

The PAD-3 functions are programmed with a 10-position DIP switch and six 3-position jumpers. The following section describes each setting.

## 5.1 DIP SWITCH SETTINGS

The 10-position DIP switch allows you to select the following:

- How long will the unit wait before indicating a loss of AC
- Which input (Input 1 or Input 2) will control the NAC outputs
- Which outputs to wire as Style Z (Class A) and Style Y (Class B)
- Auxiliary power output operation on AC power fault
- Which outputs to operate as steady outputs or ANSI temporal

Refer to Figure 2-2 for the location of the DIP switch on the circuit board assembly.

All DIP switches are factory set for off; verify proper settings for proper system operation. Slide the switches to the left for OFF and to the right for ON.

**Note:** The unit checks DIP switch settings only when reset. If you change these switch settings, you must push SW2 reset switch to recognize the new DIP switch settings.

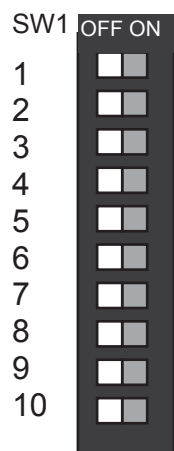

## 5.1.1 Selecting the Input/Output Configuration

Figure 5-1 shows the position of each switch on the DIP switch for various input and output configurations. The position of switch 4 through 10 does not affect the relationship of inputs to outputs.

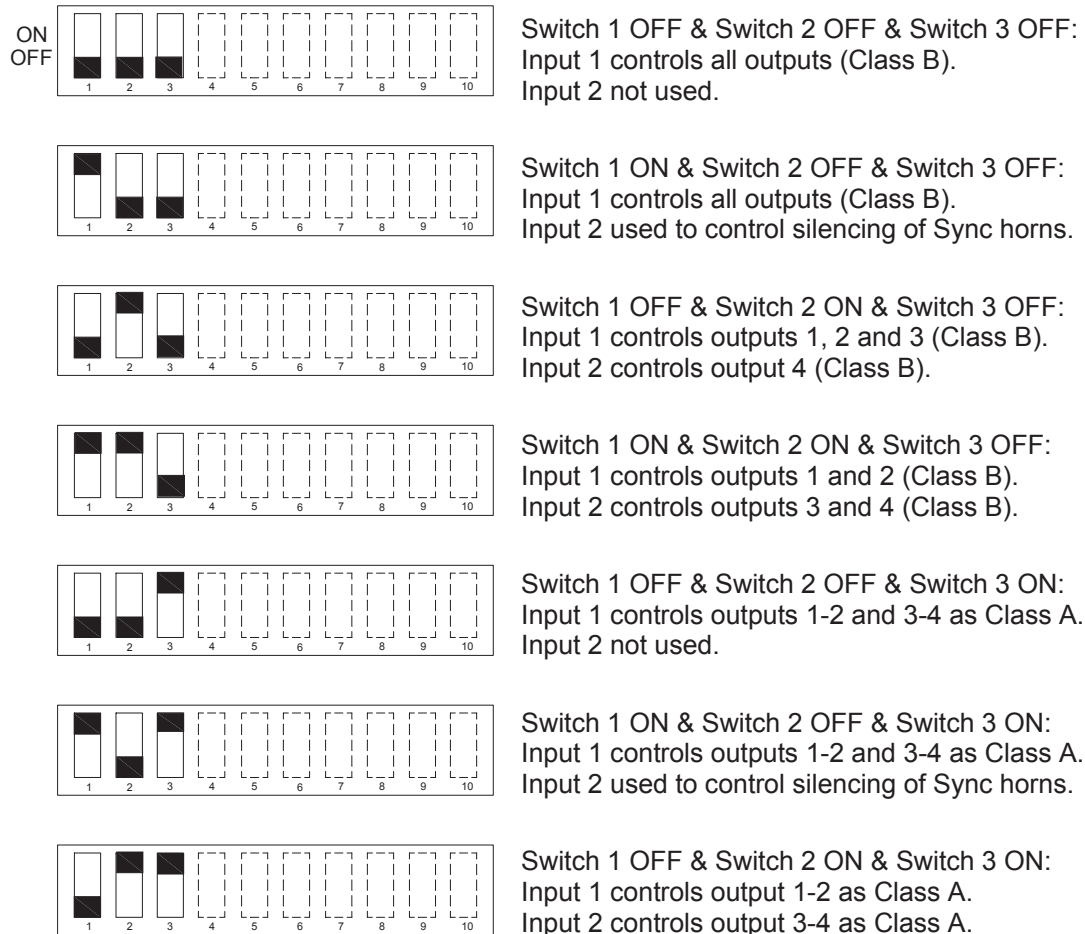

Figure 5-1. Setting DIP Switches 1-3

**Note: Changing settings for DIP switches 1-3 may affect the settings for jumpers J4-J8.**

## 5.1.2 Setting the Auxiliary Output

Switch 4 on the DIP switch determines how the auxiliary power operates.

The PAD-3 checks switch 4 only when powering up. If you change this switch, you must push switch SW2 momentarily to reset the unit to recognize the new switch setting.

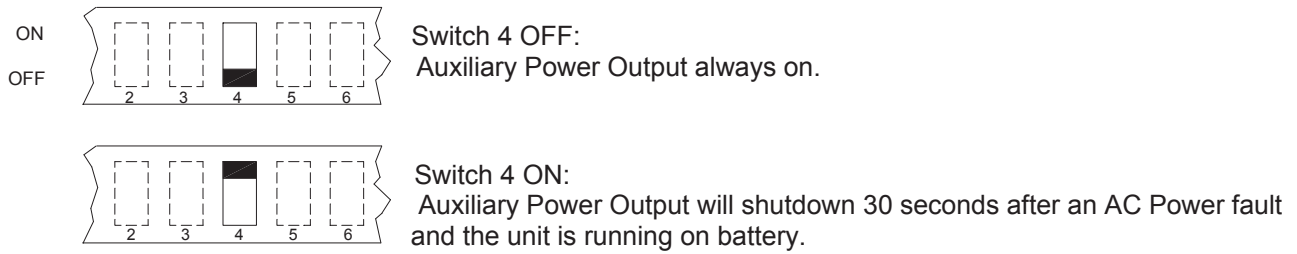

Figure 5-2. Setting DIP Switch 4

### 5.1.3 Setting the Input's Control of their NACs

DIP switch settings 5 to 8 are designed to produce outputs from a constant on input. The figures shown below compare the output patterns of configurations before and after the addition of this feature.

#### Slave Operation

The Slave operation output follows the input and can be used when the fire alarm control unit NAC is steady, coded, march time, or temporal and the desired output is the same.

#### Master Temporal Operation

#### Master Sync Strobe/Horn Operation

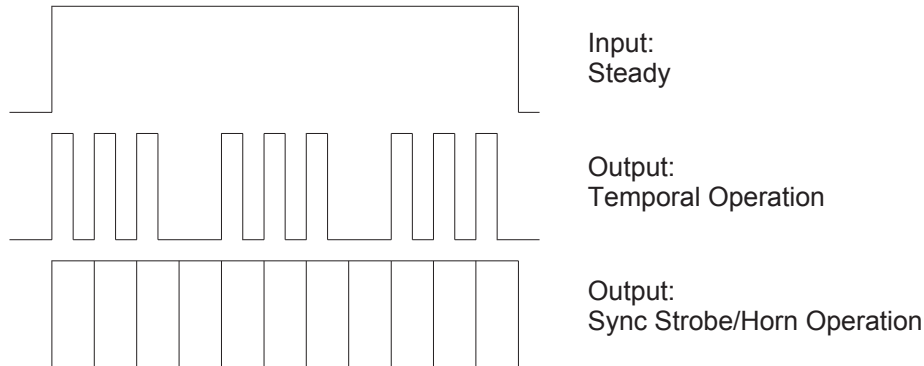

Figure 5-3. Master Input/Output Relationship

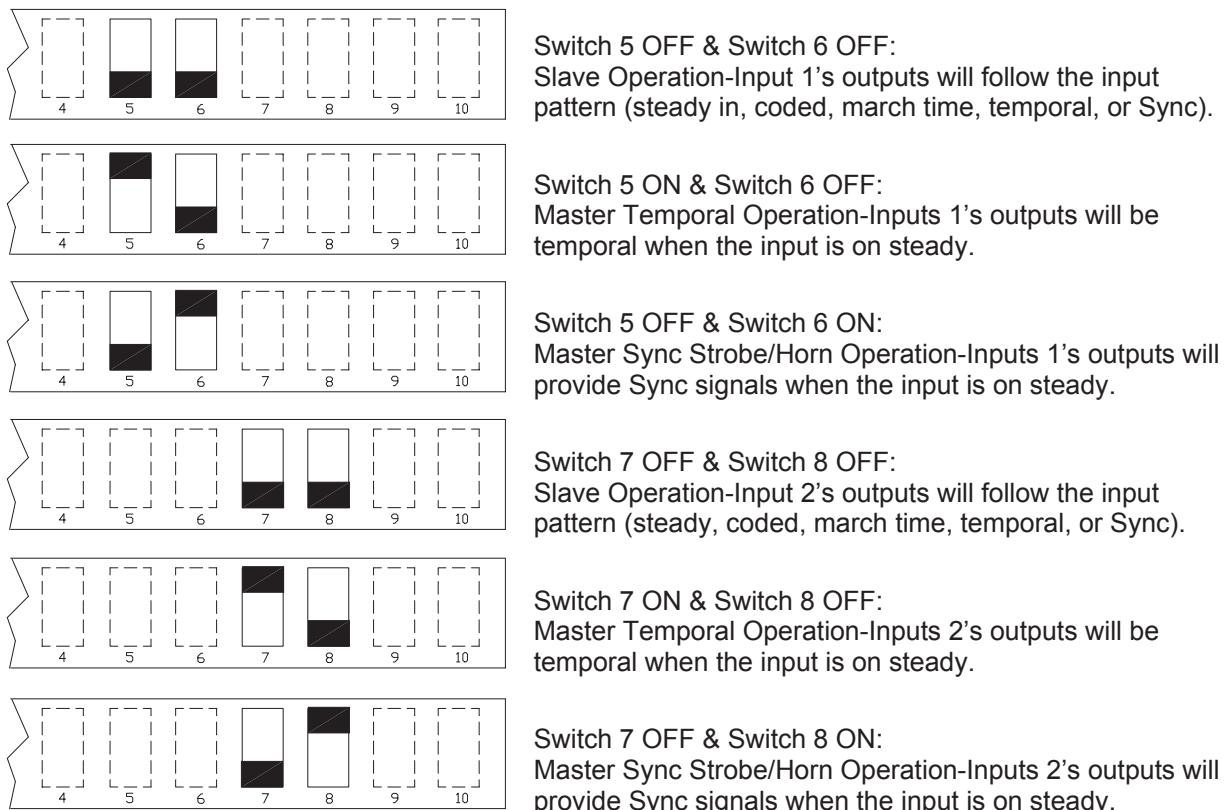

Figure 5-4. Setting DIP Switches 5-8



## 5.1.4 Setting the AC Power Fault Reporting Delay

Normal selection for reporting loss of AC is 60 minutes.

The OFF position is for test purposes only and the normal position for switch 9 is ON. For testing the Low AC reporting, you can temporarily turn switch 4 OFF without removing power.

Remember to turn the switch ON when testing is complete.

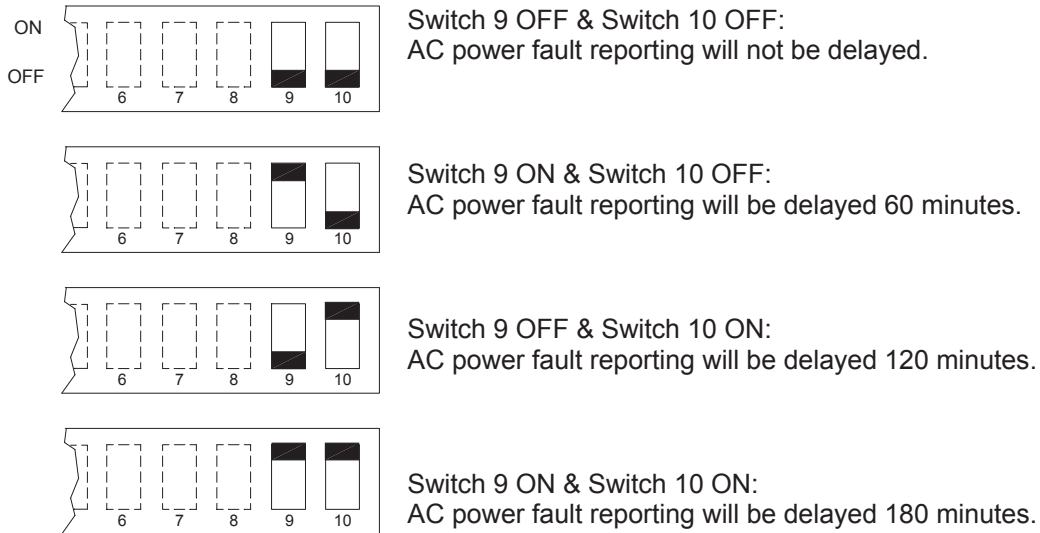

Figure 5-5. Setting DIP Switch 9 and 10

## 5.2 JUMPER SETTINGS

Factory settings are shown. See Figure 2-2 for the location of these jumpers.

**Note: Changing settings for J4-J8 also affect the settings for SW1 DIP switches 1-3.**

J4 – NAC 1-2 Configuration (J5 must be set the same)



- 1 Class B
- 2
- 3 Class A

J5 – NAC 1-2 Configuration (J4 must be set the same)



- 1 Class B
- 2
- 3 Class A

J7 – NAC 3-4 Configuration (J8 must be set the same)



- 1 Class B
- 2
- 3 Class A

J8 – NAC 3-4 Configuration (J7 must be set the same)



- 1 Class B
- 2
- 3 Class A

J9 – Ground Detection Configuration



- 1 Enabled
- 2
- 3 Disabled

J10 – Battery Charger Configuration



- 1 Enabled
- 2
- 3 Disabled

## 6. REFERENCE DATA

This section provides reference for the following topics:

- Wire selection guides
- Battery size calculations

### 6.1 WIRE SELECTION GUIDES

#### 6.1.1 Resistance of Solid Copper Wire

AWG	Ohms per Thousand Feet*
18	8.08
16	5.08
14	3.19
12	2.01

\*NEC Chapter 9, Table 8.

## 6.2 BATTERY SIZE CALCULATIONS

Device	Quantity	Current per device (amps)	Standby current (A)	Alarm current (A)
Multiply	This column times this column		=current	
1) PAD-3 Control Unit	1 or 2 <sup>A</sup>	Aux. Pwr. always on (SW1-4 off) – 0.035A Aux. Pwr. off @ AC fail (SW1-4 on) – 0.015A		
2) PAD-3 Control Unit	1 or 2 <sup>A</sup>	0.140 per PAD-3		
<b>Notification Appliances – refer to the device manual for ratings</b>				
Model No.	Quantity	Alarm current		
3)				
<b>Auxiliary Devices – refer to the device manual for ratings</b>				
Model No.	Quantity	Standby current	Alarm current	
4)				
5) Total amperage required (totals for line 1, 2, 3 and 4) <sup>B,F</sup>			A	A
6) Number of Standby Hours required (4, 24, or 60, per NFPA 72)			Hrs.	
7) A.H. for Standby (without AC reporting delay) Multiply line 5 times line 6				
8) A.H. for AC reporting delay <sup>C</sup>			A.H.	
9) Total A.H for Standby (add line 7 and line 8)			A.H.	
10) Length of Alarm Operation <sup>D</sup>				Hrs.
11) A.H for Alarm (multiply line 5 times line 10)				A.H.
12) Total Standby and Alarm A.H required (add line 9 and line 11)				A.H
13) Battery De-rating Factor			1.25	
14) Battery Amp-Hour Rating required (multiply line 12 times line 13) <sup>E</sup>				A.H.

- A. Up to two PAD-3 boards can be connected to a common battery set. When calculating for 2 PAD-3 boards
- Both boards must be mounted on System 3 rails in the same enclosure.
  - One of the boards must have the battery charger circuit disconnected.
  - The board with the ACTIVE charger is limited to 1.50 amps for the aux. power (terminals 18 and 19).
  - Both sets of battery connections are to be connected to the same battery set using 2 battery connection splitters, P/N 230-299203.
- B. The Alarm Current must never exceed 6.14 amps! (6 amps output for NACs and aux. power, 0.14 amps for internal operation)
- C. A.H. required for AC reporting delay – 0 hours = 0.00 A.H.; 60 minutes = 0.24 A.H.; 120 minutes = 0.60 A.H.; 180 minutes = 0.96 A.H.
- D. Alarm operation length while on battery power varies with application and local codes. Check with the AHJ to determine if 5 minutes (0.0833 hours), 30 minutes (0.5 hours), 1 hour, or 2 hours of alarm operation is required.
- E. Battery rating required cannot exceed 15 A.H. For battery ratings 7.0 A.H. or below, the full 3.0 amps are available for auxiliary power (terminals 18 and 19). For battery ratings between 7.0 and 15 A.H., 1.50 amps are available for auxiliary power.
- F. The following table shows the maximum standby current allowed: When the Auxiliary Power Output is programmed to shutdown on AC power fault (SW1.4-ON), up to 3.015 Amps is allowed.

Standby Hours	Maximum Standby Current (A.)		
	7AH	10AH	15AH
4	1.242	1.842	2.842
24	0.207	0.307	0.473
60	0.082	0.122	0.189
90	0.055	0.081	0.126

## 7. COMPATIBLE DEVICES

See Siemens P/N 315-096363 for compatible notification appliances.

## 8. TROUBLESHOOTING

This section describes the LED states and provides possible trouble conditions of the PAD-3.

### 8.1 LED INDICATORS

Light-emitting diodes (LEDs) indicate fault and normal conditions. The seven LEDs indicate a fault condition in one of the circuits (either outputs 1 through 4, auxiliary power, ground fault, or battery). A fault condition in the LEDs corresponding circuit will turn on the LED (labeled on the board). The POWER LED will normally be on and turn off to indicate an AC Fail condition. See Figure 2-2 for locations of LEDs. Their functions are as follows:

DESIGNATION	MARKING	COLOR	DESCRIPTION
DS1	OUTPUT1	Yellow	NAC 1 trouble LED.
DS2	OUTPUT2	Yellow	NAC 2 trouble LED.
DS3	OUTPUT3	Yellow	NAC 3 trouble LED.
DS4	OUTPUT4	Yellow	NAC 4 trouble LED.
DS5	AUX. P.S.	Yellow	Auxiliary power output trouble LED
DS6	GRND	Yellow	Ground fault LED
DS7	BATTERY	Yellow	Battery trouble LED
DS8	POWER	Green	AC Power normal LED

### 8.2 IMPROPER OPERATION

If there is improper operation of the activation of the outputs, check for the following:

Was the reset switch SW2 pressed after changing the DIP switch settings?

Are the DIP switch settings correct for the application?  
(See Section 5.1)

Are the jumper settings correct for the application?  
(See Section 5.2)

Are the inputs activating correctly?

Are the correct type of notification appliances connected?  
(Conventional or Sync Strobes/Horns)

## 8.3 TROUBLE CONDITIONS

**CAUTION:** Troubleshooting is to be done only by qualified personnel who have been trained to repair and test this fire alarm accessory.

Trouble conditions are sent to the fire alarm control unit from the trouble relay or associated input trouble relay.

DESCRIPTION	PROBABLE CAUSE
<i>POWER</i> LED (DS8) not lit.	No AC input power. Low AC input power (Less than 90VAC). Notes: 1. DIP Switch SW1 switches 9 & 10 set the delay for reporting AC power faults from 0 to 24 hours. 2. The green <i>POWER</i> LED turns off as soon as low AC or loss of AC occurs (does not wait for delay). 3. The trouble restores within 1 minute of the AC voltage restoring to normal level.
<i>BATTERY</i> LED (DS7) lit.	Low battery input power (Less than 21.4VDC). No battery input power. Shorted battery input. Open polyswitch F2 or F3 (Disconnect battery and reconnect to reset). Note: The battery input is checked about once a minute for troubles and restorals.
<i>GRND</i> LED (DS6) lit.	One or more external field connections shorted to earth ground (Less than 40K ohms). Note: When the PAD-3 power is referenced to the control unit power; the ground detection circuit may be disabled with jumper J9.
<i>AUX. P.S.</i> LED (DS5) lit.	Overcurrent condition on the auxiliary power output. (Trip with greater than 3.7Amps.). Note: The circuit automatically tries to restore about once a minute.
<i>OUTPUT1</i> LED (DS1) lit or <i>OUTPUT2</i> LED (DS2) lit or <i>OUTPUT3</i> LED (DS3) lit or <i>OUTPUT4</i> LED (DS4) lit.	Associated NAC is open (Greater than 49K ohms). Associated NAC is shorted (Less than 18K ohms). Associated NAC has an overcurrent condition (Trip with greater than 3.7Amps.). Note: The circuit automatically tries to restore about once a minute.

## 8.4 FUSE REPLACEMENT

FUSE	DESCRIPTION
F1	5A 250V 3AG Axial Lead Fuse
F2	5A RUE 500 Resettable Fuse
F3	9A RUE 900 Resettable Fuse

## 9. BATTERY MAINTENANCE

Perform the following tests at the recommended interval. Replace the battery set every four years or if any of the test criteria are not met.

### Initiation / Reacceptance

1. Charger Test—With the batteries fully charged and connected to the charger, measure the voltage across the battery set. It must read 27.3V +/- 0.3V.
2. Discharge Test—With full system alarm load, the voltage on a fully charged battery must not fall below 20.4V after 30 minutes.
3. Load Voltage Test—With full system alarm load, the voltage on a fully charged battery must not fall below 24.6V after one minute.

### Testing Interval

1. Semiannually—Perform the Load Voltage Test.
2. Annually—Perform the Charger Test and Discharge Test.



# 10. GLOSSARY

**Alarm Signal.** A signal that indicates the presence of an emergency requiring immediate action, such as an alarm for fire from a manual station, a waterflow alarm, or a automatic smoke detector.

**Alarm System.** A combination of compatible initiating devices, control units, and notification appliances designed and installed to produce an alarm signal in the event of a fire.

**Audible Signal.** A sound made by one or more audible notification appliances, such as bells or horns, in response to the operation of an initiating device.

**Authority Having Jurisdiction (AHJ).** The organization, office, or individual responsible for approving equipment, installations or procedures.

**Class A Circuit.** An initiating device or notification appliance circuit in which all components remain fully functional when a single open or ground exists in the circuit.

**Class B Circuit.** An initiating device or notification appliance circuit in which some or all components may be disabled when a single open or ground exists in the circuit.

**End Of Line (EOL).** A device used to terminate a supervised circuit.

**General Alarm.** A term usually applied to the simultaneous operation of all the notification appliances on a system.

**Ground Fault.** A trouble condition in which a low resistance has been detected between the system wiring and conduit ground.

**Initiating Device Circuit (IDC).** A circuit to which initiating devices are connected.

**Labeled.** Equipment or materials to which a label, symbol, or other identifying mark of an organization acceptable to the AHJ and concerned with product evaluation has been attached. The organization's label indicates that the manufacturer complies with appropriate standards, performs in a specified manner and maintains periodic inspection of the production of such labeled equipment or materials.

**Listed.** Equipment or materials included in a list published by an organization acceptable to the AHJ and concerned with product evaluation. Inclusion in the list indicates that the equipment or materials comply with appropriate standards, and has been found suitable for use in a specified manner. The manufacturer maintains periodic inspection of production of listed equipment or materials.

**NEC.** National Electrical Code also published as NFPA standard 70.

**Notification Appliance.** An electrically operated appliance used to indicate the system status such as a bell, horn, strobe light or speaker.

**Notification Appliance Circuit (NAC).** A circuit to which notification appliances are connected.

**Power Supply.** That portion of the fire alarm control unit which provides the power needed to operate all control unit modules, as well as that, needed to operate all electrically powered initiating devices and all notification appliances.

**Trouble Signal.** An audible signal indicating trouble of any nature, such as a circuit break or ground, occurring in the device or wiring associated with a fire alarm signal.

**Zone.** A designated area of a building. Zone is commonly interchanged with initiating device circuit.





Siemens Building Technologies, Inc.  
8 Fernwood Road  
Florham Park, New Jersey 07932

P/N 315-099082-9

Siemens Building Technologies, Ltd.  
2 Kenview Boulevard  
Brampton, Ontario L6T 5E4 Canada