



**Trinity Tft155-175-200-250
High Efficiency Gas
Modulating-Condensing Boiler**

Submittal Sheet

Section 1 - Specifications
Section 2 - Dimensions
Section 3 - Electrical

Project Name: _____ **Date:** _____
Location: _____
Engineer: _____
Contractor: _____ **Rep:** _____

1 SPECIFICATIONS

General Specifications

- ▶ **Product Features**
 - Certified to ANSI Z21.13 / CSA 4.9 Gas-fired Boiler Standard (pending)
 - ASME "H" stamped boiler, designed and constructed in compliance with the ASME Boiler and Pressure Vessel Code Section IV
 - SA240-S43932 Stainless Steel Heat Exchanger
 - Maximum operating pressure 80 psi [551.6 kPa]
 - Field conversion from Natural Gas (factory) to Propane
 - Modulating burner, up to 8:1 turndown
 - Direct Spark Ignition
 - Wall (standard) or floor mounting (w/ opt. kit, NTI part # 84630)
 - Zero clearance to combustibles
- ▶ **Optional sidewall vent kit (NTI part # 82666 & 84357)**
- ▶ **Factory Supplied Items**
 - 10K thermistor outdoor sensor
 - 30PSI [206.8 kPa] ASME Relief Valve
 - 60PSI [413.7 kPa] Pressure Gauge
- ▶ **Control Features**
 - Integral microprocessor safety control
 - 2 central heat inputs (high & low temperature)
 - Domestic Hot Water Priority
 - Outdoor reset
 - Warm weather shutdown
 - Lead-Lag up to 8 Tft and Lx series boilers
 - Integrated Modbus RTU for connection to BMS gateways

Water Connections NPT, in.	Gas Connection NPT, in.	Vent/Air-Intake Pipe Diameter in. [mm]	Vent/Air- Intake Max. Length ft. [m]	Approx. Weight with Water lb. [kg]
1 ¼ (Male)	½ (Male)	3 [76]	100 [30.5]	180 [81.8]

Heating Specifications

Model	Input		Heating Capacity BTU/hr [kW]	AFUE %	Net I=B=R Rating BTU/hr [kW]
	Min BTU/hr [kW]	Max BTU/hr [kW]			
Tft155	31,000 [9.0]	155,000 [45.4]	144,000 [42.2]	95	125,000 [36.6]
Tft175	31,000 [9.0]	175,000 [51.3]	163,000 [47.7]		141,000 [41.3]
Tft200	31,000 [9.0]	200,000 [58.6]	185,000 [54.1]		160,000 [46.9]
Tft250	31,000 [9.0]	250,000 [73.3]	230,000 [67.3]		199,000 [58.3]

Performance Specifications

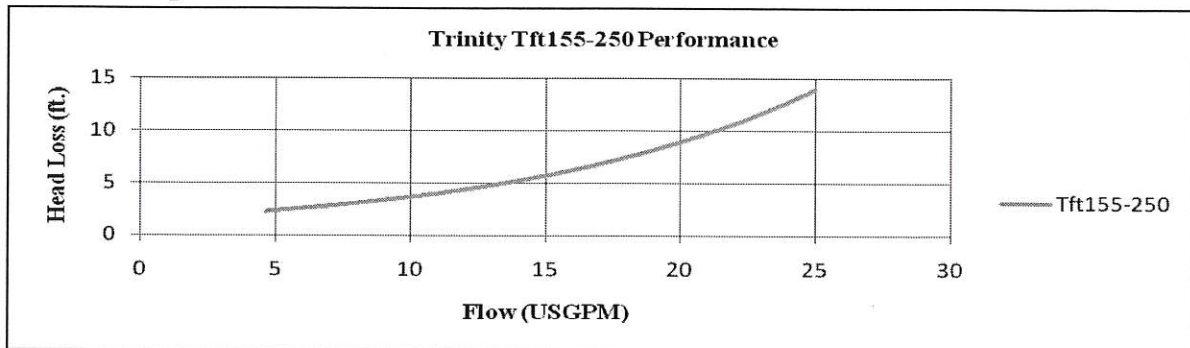

NY Thermal Inc.

65 Drury Cove Road, Saint John, NB E2H 2Z8 Canada

Technical Service: 1-800-688-2575 Fax: 1-506-432-1135 Web: [http:// www.nythermal.com](http://www.nythermal.com)

NY Thermal Inc. reserves the right to change these specifications without notice



**Trinity Tft155-175-200-250
High Efficiency Gas
Modulating-Condensing Boiler**

Submittal Sheet

2 DIMENSIONS

Product Dimensions – in. [mm]

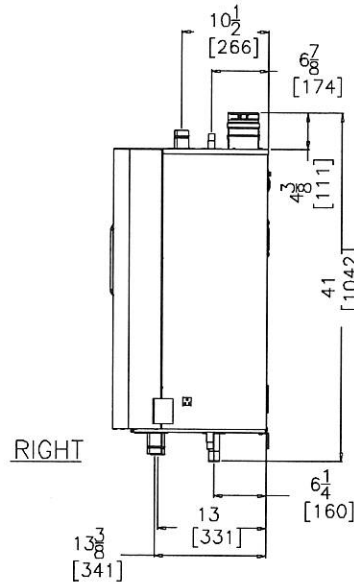
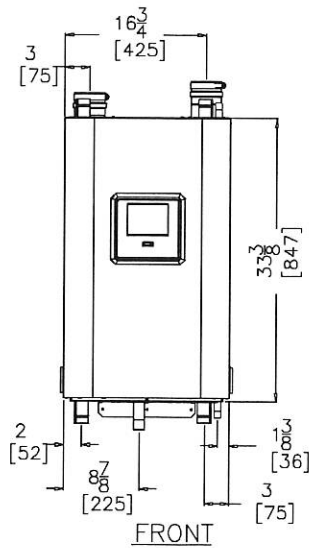
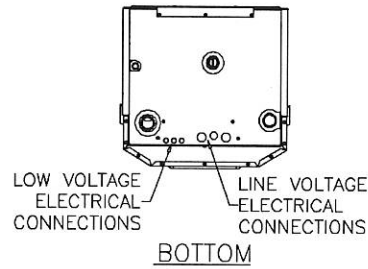
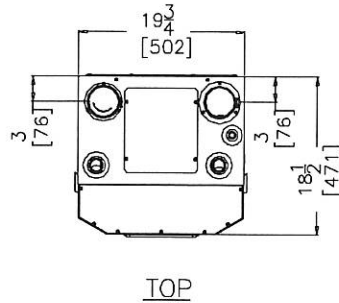

Recommended Clearances – in. [mm]

Front	Top	Sides	Back	Bottom	Flue Pipe
36 [914]	24 [610]	12 [305]	0	24 [610]	1 [25]



NY Thermal Inc.

65 Drury Cove Road, Saint John, NB E2H 2Z8 Canada

Technical Service: 1-800-688-2575 Fax: 1-506-432-1135 Web: [http:// www.nythermal.com](http://www.nythermal.com)

NY Thermal Inc. reserves the right to change these specifications without notice



**Trinity Tft155-175-200-250
High Efficiency Gas
Modulating-Condensing Boiler**

Submittal Sheet

3 ELECTRICAL

Simplified Wiring Diagrams

Line Voltage Electrical:

- ▶ 120VAC / 60 Hz / 1 Phase / 12 Amp
- ▶ Barrier Strip for field wiring terminations
- ▶ 3 Pump outputs
 - Indirect Domestic Hot Water (Pump A)
 - Boiler (Pump B)
 - Central Heat (Pump C)

Note: Pumps are field supplied.

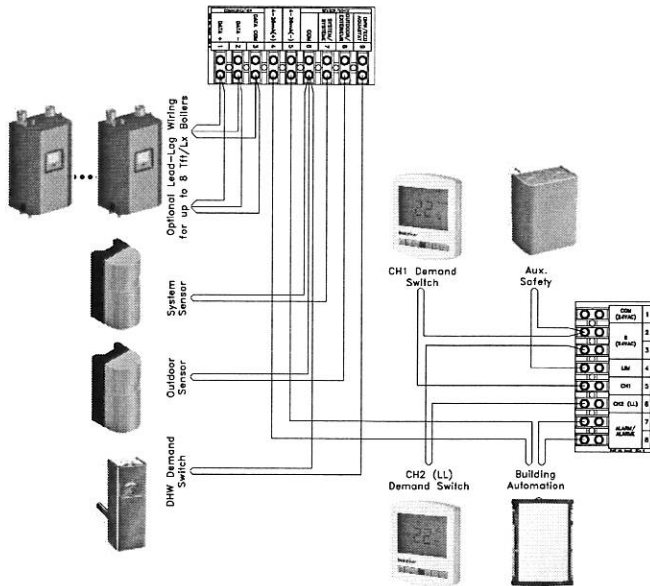
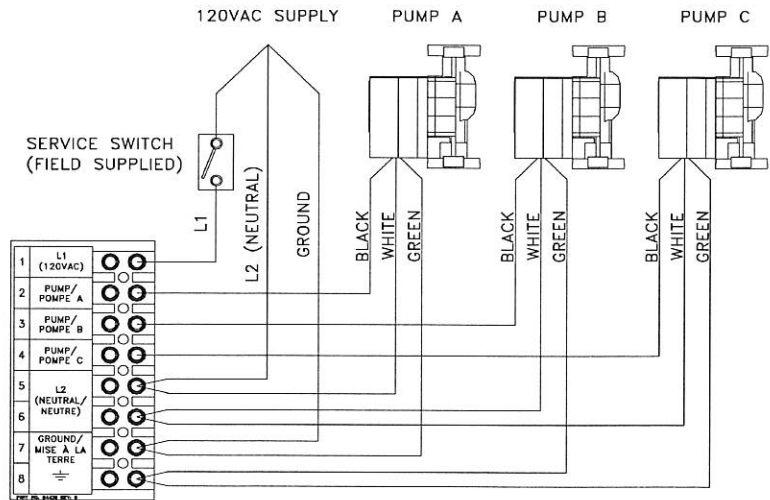

Low Voltage Electrical:

- ▶ Barrier Strip for field wiring terminations
- ▶ 120/24 VAC Transformer 40VA (factory supplied)
- ▶ Inputs
 - CH1 thermostat (by others)
 - CH2 thermostat (by others)
 - Indirect DHW aquastat (by others) or DHW Tank sensor (factory option)
 - External Limit (by others)
 - Outdoor sensor (factory supplied)
 - System sensor (factory option)
 - 4-20mA external modulating control (by others)
- ▶ Outputs
 - Alarm dry contact (24VAC 0.63A max.)
- ▶ EIA-485 Modbus communications for Lead-Lag
- ▶ EIA-485 Modbus to BMS gateways (not shown). Optional available gateways:
 - BACnet/N2- NTI part # 84946
 - LonWorks- NTI part # 84947



NY Thermal Inc.

65 Drury Cove Road, Saint John, NB E2H 2Z8 Canada

Technical Service: 1-800-688-2575 Fax: 1-506-432-1135 Web: [http:// www.nythermal.com](http://www.nythermal.com)

NY Thermal Inc. reserves the right to change these specifications without notice