

10 | 3RD FLOOR - KING - M
1/4" = 1'-0"

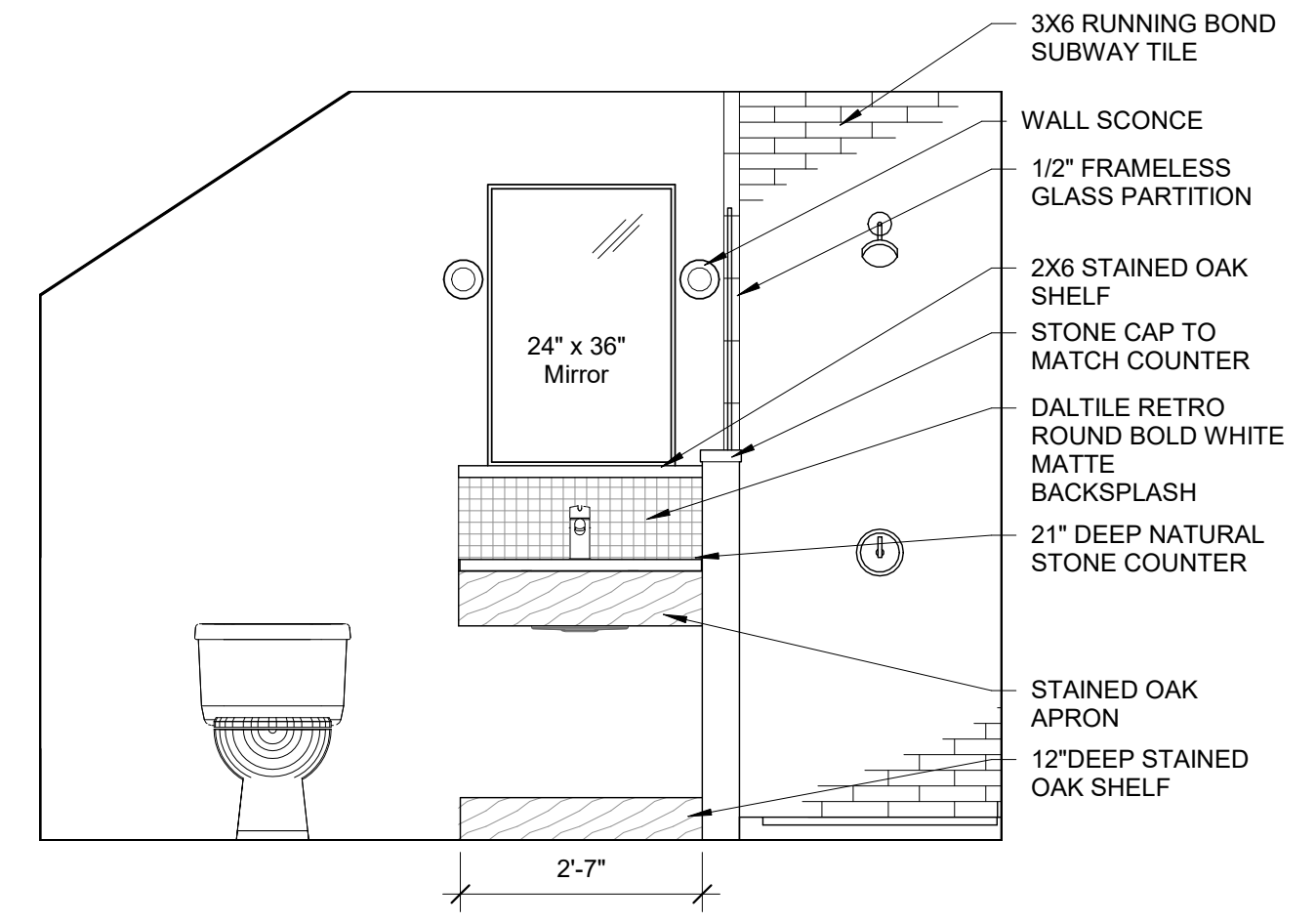

9 | KING M VANITY AND SHOWER ELEVATION
1/2" = 1'-0"

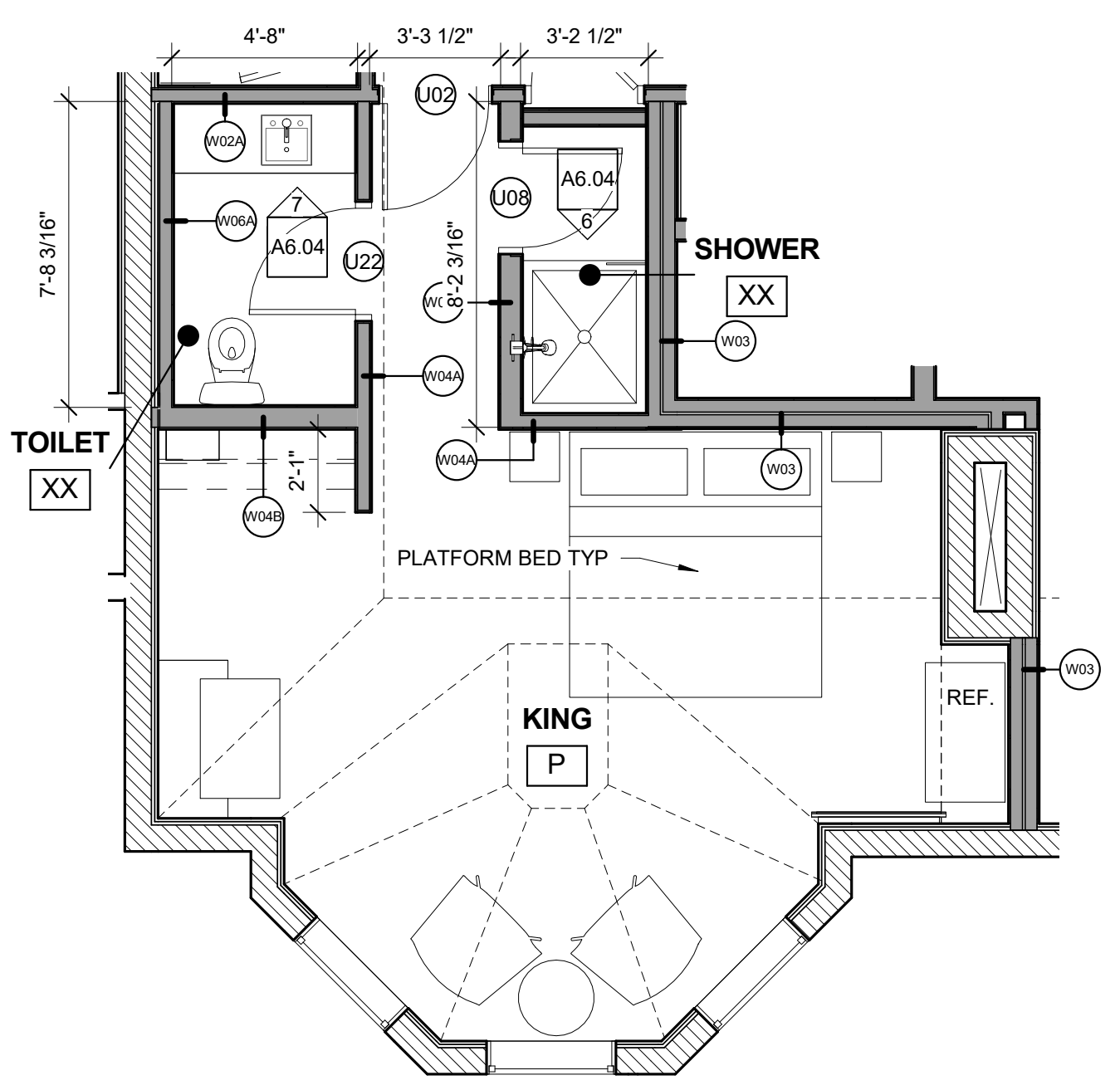

8 | 3RD FLOOR - KING - P
1/4" = 1'-0"

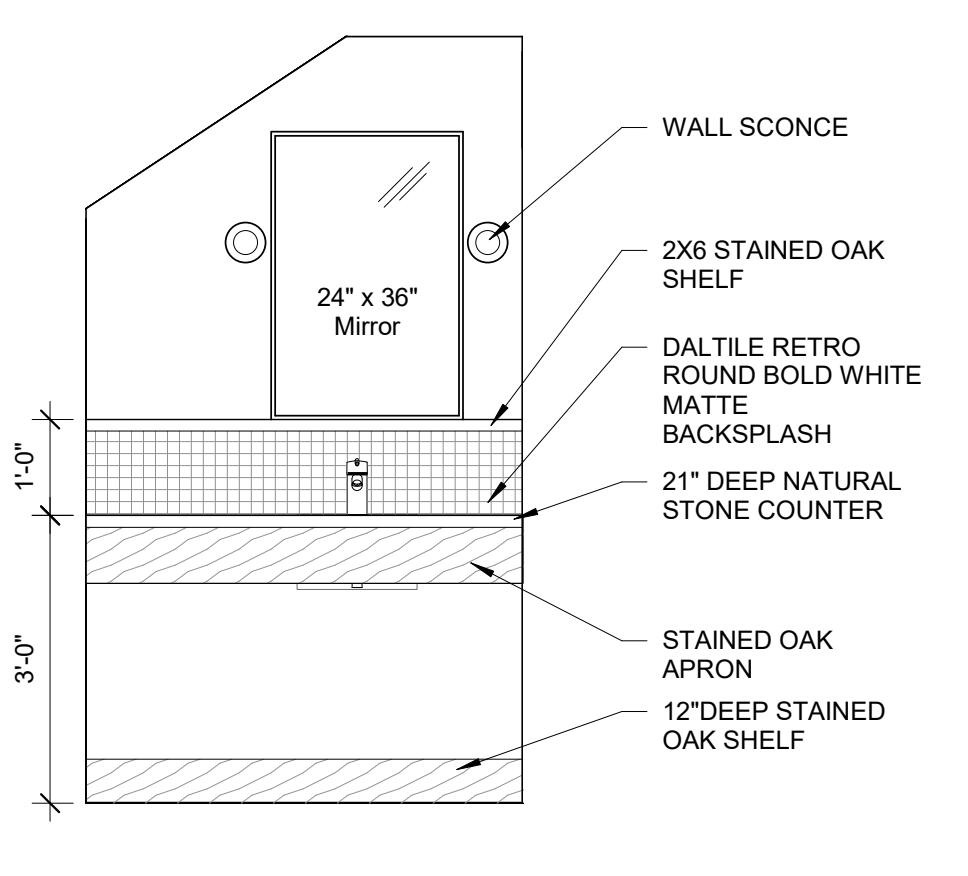

7 | KING P VANITY ELEVATION
1/2" = 1'-0"

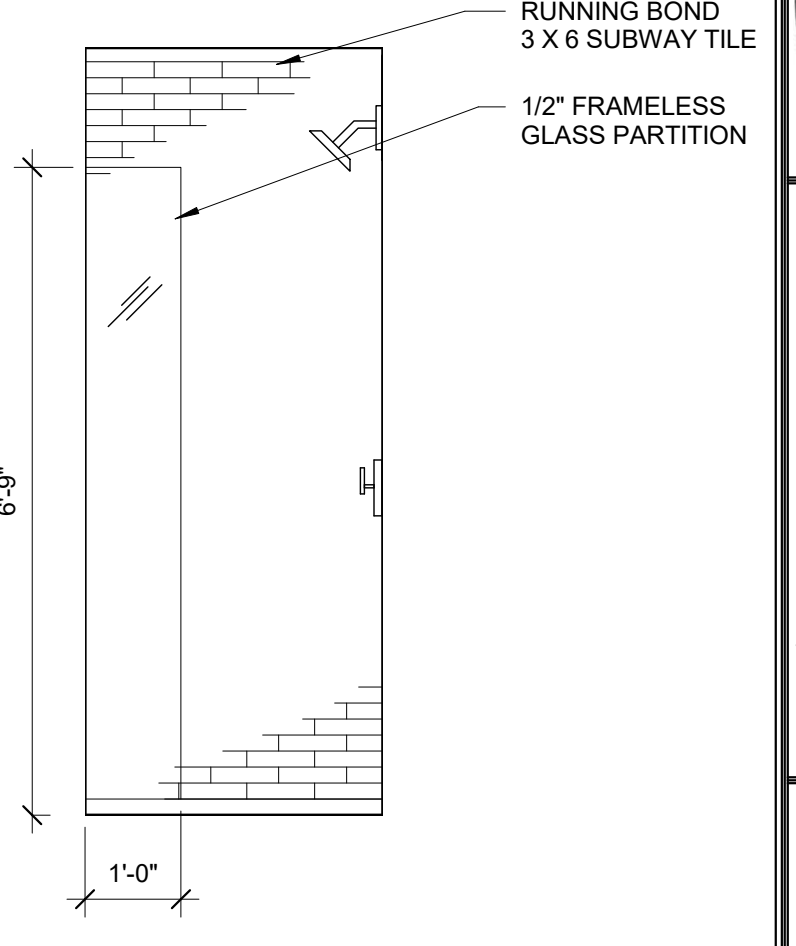

6 | KING P SHOWER
1/2" = 1'-0"

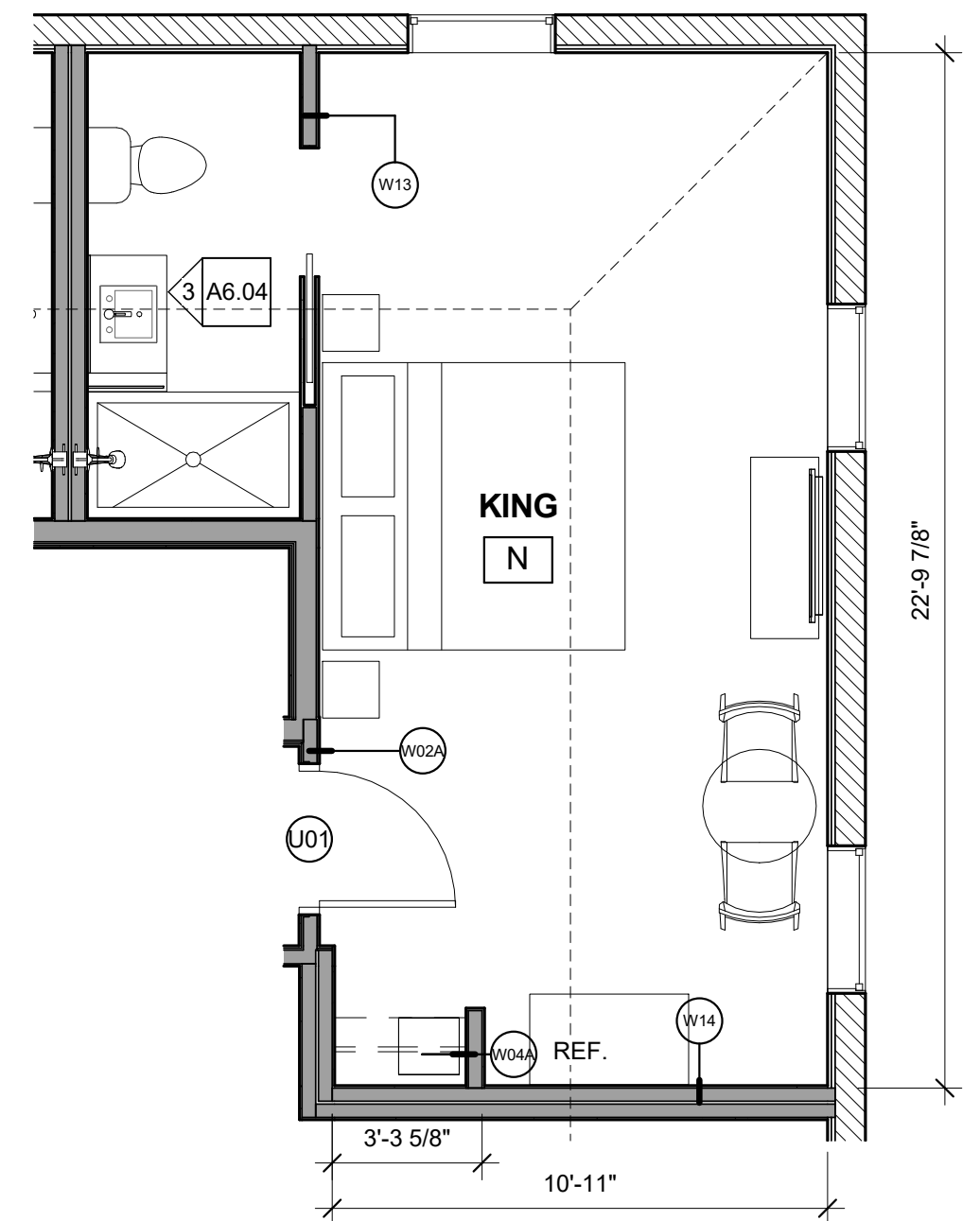

5 | 3RD FLOOR - KING - N
1/4" = 1'-0"

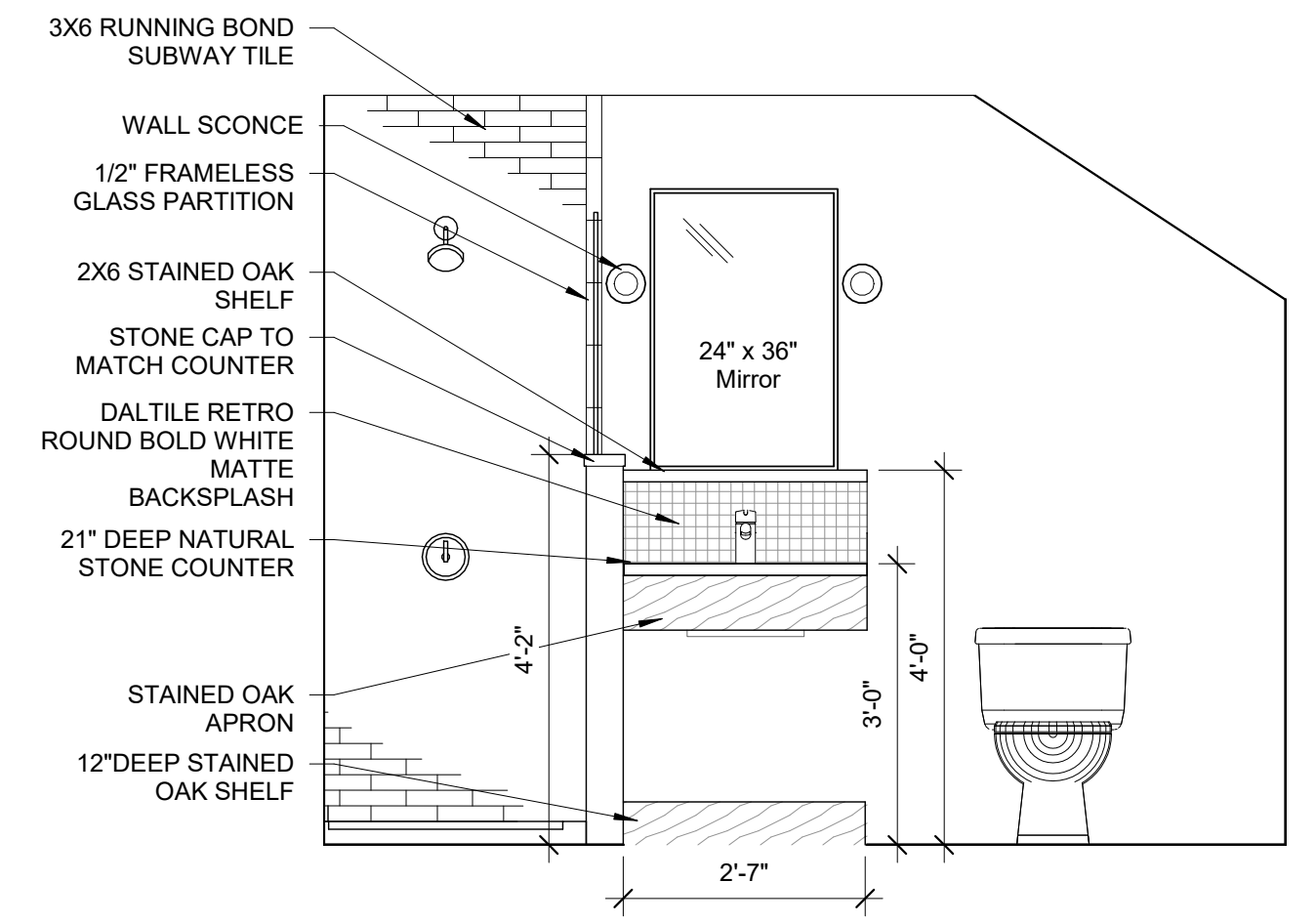

3 | KING M BATHROOM ELEVATION
1/2" = 1'-0"

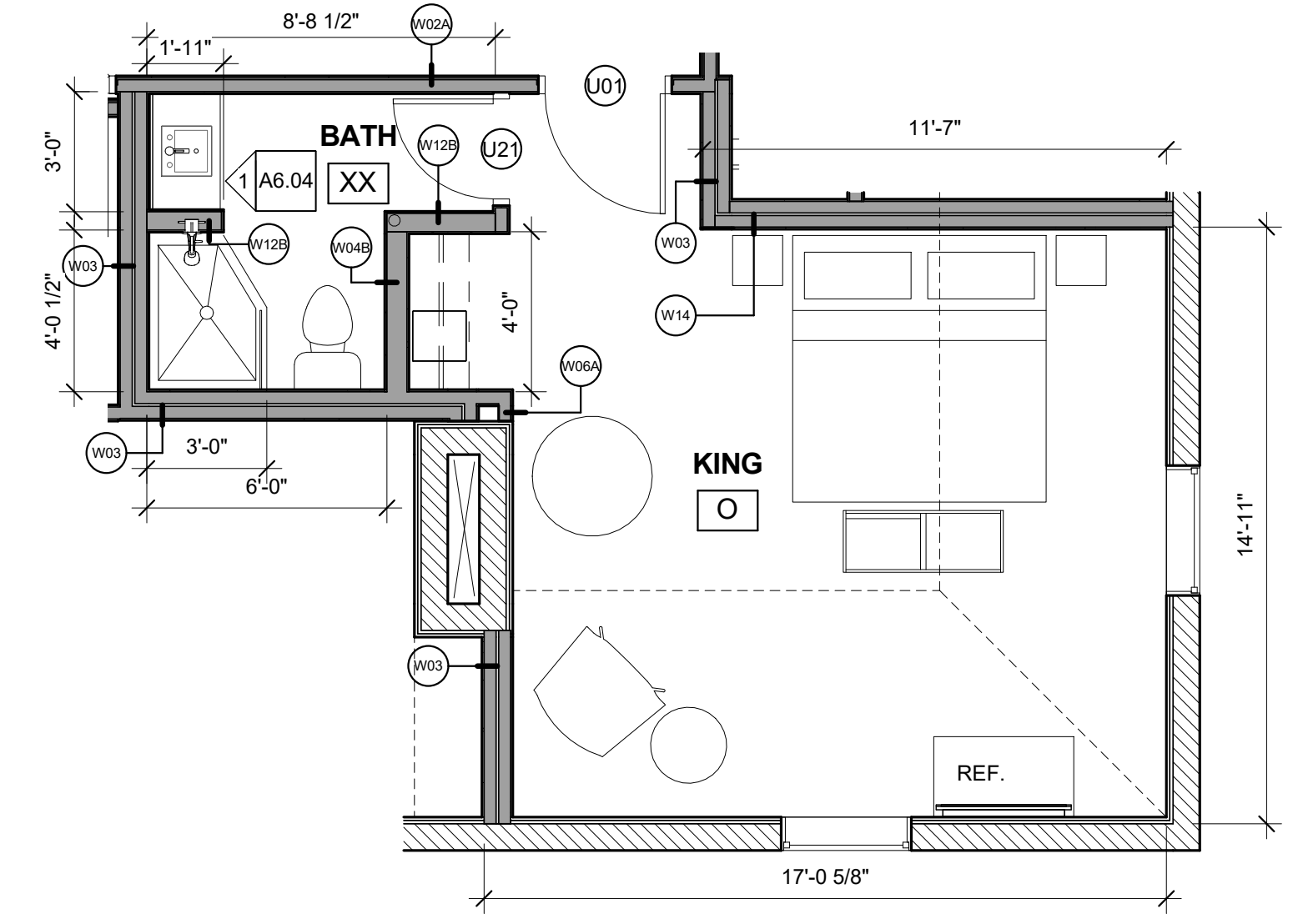

2 | 3RD FLOOR - KING - O
1/4" = 1'-0"

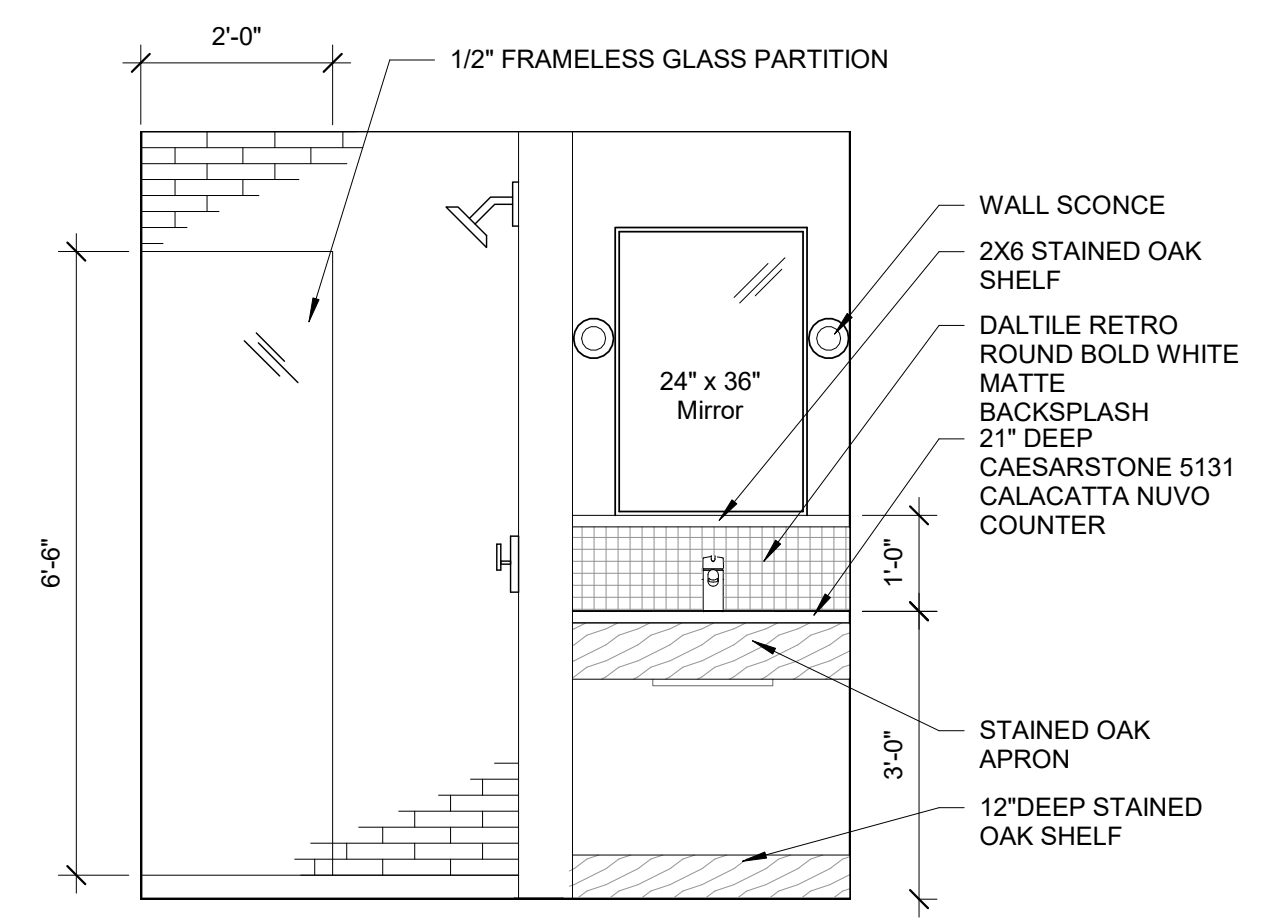

1 | KING O VANITY/ SHOWER
1/2" = 1'-0"



Prepared For:
747 CONGRESS LLC

Consultant:
ARCHETYPE architects
48 Union Wharf Portland, Maine 04101
(207) 772-6022 ARCHETYPE@ARCHETYPE.COM

Project:
THE FRANCIS
749 CONGRESS ST
PORTLAND, ME 04102

Revisions:

Date: 07 OCT 2016
Scale: As indicated
ENLARGED ROOM PLANS

A6.04