

TYPICAL SECTION  
NO SCALE

TABLE 1.  
Screws: Metal-to-Plywood Connections<sup>(a)</sup>

Depth of Threaded Penetration (in.)	Ultimate Lateral Load (lb) <sup>(b)</sup>					
	Wood Screws			Sheet Metal Screws		
	#8	#10	#12	#8	#10	#12
1/2	415	(500)	590	465	(565)	670
5/8	-	-	-	500	(600)	705
3/4	-	-	-	590	(655)	715

(a) Plywood was C-D grade with exterior glue (all plies Group 1), face grain parallel to load. Side plate was 3/16"-thick steel.

(b) Values in parentheses are estimates based on other tests.

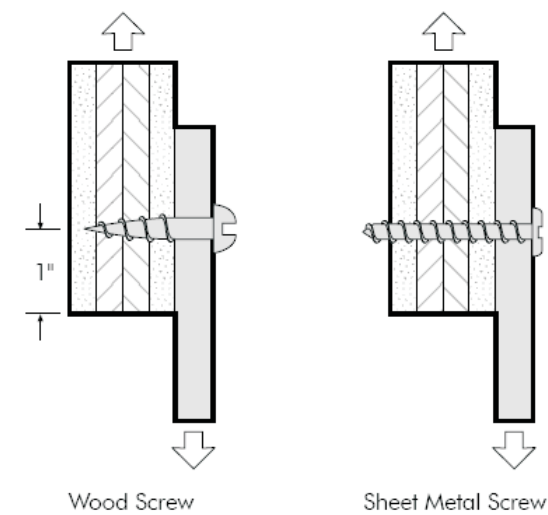

PERMIT DRAWING

STATE THEATER  
3184.2

LOCATION: 609 CONGRESS STREET

PORTLAND, MAINE

DRAWING NO.: 5 OF 5

DRAWN BY: PFAT/BK REP:PB

DATE: 06.19.2017

QUOTE: @1824

GEN REF.:

**NEOKRAFT**  
SIGNS

NEOKRAFT SIGNS INC. NEOKRAFT.COM  
686 MAIN STREET T:207.782.9654 F:782.0009  
LEWISTON, MAINE 04240 1.800.339.2258

© COPYRIGHT 2016, BY NEOKRAFT SIGNS, INC.