



**667 Congress Street**

**Grease Duct Fire Wrap**

## FireMaster® FastWrap® XL



Datasheet Code US: 714-236

© 2014 Thermal Ceramics is a business of Morgan Advanced Materials

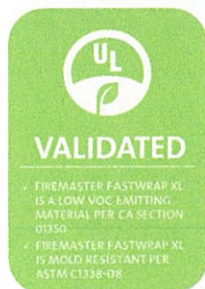

\* Commonly referred to test method CA Section 01350 is CDPH Standard Method for the Testing and Evaluation of Volatile Organic Chemical Emissions from Indoor Sources Using Environmental Chambers Version 1.1, Feb 2010

**Grease Duct Enclosure System**  
**Air Ventilation Duct Enclosure System**  
**Product Data & Installation Guide**

### 1. Product Description

Thermal Ceramics FireMaster® FastWrap XL is a flexible blanket composed of high temperature fibers classified for applications to 2192°F (1200°C) and fully encapsulated in a durable glass fiber reinforced foil facing for easy handling and installation. Thermal Ceramics FastWrap XL is UL and ULC Listed for 1 and 2 hour fire resistive enclosure protection, zero clearance for kitchen exhaust ducts, electrical circuit protection, and as a component in UL firestop designs for fire resistance rated floors, ceilings, and walls. The core fibers in FastWrap XL are manufactured using Thermal Ceramics patented Superwool® fiber which is an alkaline-earth silicate wool with low biopersistence and therefore increased safety for installers. FastWrap XL is under UL's Follow-Up Service Program to ensure the consistent quality essential to this life-safety application.

### Product Features

- Thin and Lightweight at 1-1/2" (38mm) thick, 6 pcf (96 kg/m<sup>3</sup>) density
- Contours easily to complex duct designs
- Grease duct installation UL and ULC Listed with butt joints at all seams on both layers
- Fully foil encapsulated for fast and clean installation
- Contains 2192°F (1200°C) rated fibers
- Microbial Resistance validated by UL Environment
- Good sound absorption
- Compliant to IMC, NFPA 96, UMC, CMC, CNBC

### 2. Applications

- 2 hour enclosure and firestop system for kitchen exhaust duct
- Zero clearance to combustibles
- 1, 2 and 3 hour enclosure and firestop system for hazardous exhaust ducts, pressurization ducts, clothes dryer exhaust ducts, trash and linen chutes, and other fire rated HVAC ducts
- 1 hour electrical circuit integrity protection
- Engineered and tested solutions for fire protection of structural steel and storage vessels per ASTM E119, ISO 834, and UL1709

### 3. Specifications - Division 23 07 00 (or 15080)

CSI Spec and AutoCAD available online, [www.arcat.com/sd/clients/thermcer.html](http://www.arcat.com/sd/clients/thermcer.html).

Thermal Ceramics FireMaster FastWrap XL is a flexible high temperature insulation rated to 2192°F (1200°C) that is fully encapsulated in FSP facing. The duct enclosure system shall be listed by UL and /or ULC per ASTM E 2336, CAN/ULC S144 and ISO 6944 for 1-, 2- and 3-hour rating and zero clearance to combustibles, and tested per ASTM E84 for a flame/smoke rating less than 25/50. Insulation shall have a nominal thickness of 1-1/2 inches (38 mm) and density of 6 lbs/ft<sup>3</sup> (96 kg/m<sup>3</sup>). Insulation shall have a R-Value of 7.3 at 75°F. Installation shall be in strict accordance to manufacturers published installation instructions, UL or ULC Listings, and shop drawings. FastDoor™ XL shall be used for duct access where specified or as required by code.

## FireMaster® FastWrap® XL



### 4. Physical Characteristics

Product	Unit	Size	Units/Ctn.	Wt./Ctn.
FastWrap XL	Roll	1-1/2" x 24" x 25'	1	37.5 lbs.
FastWrap XL	Roll	1-1/2" x 48" x 25'	1	75 lbs.

### 5. Performance Specifications

Reference Standard	Standard No.	Performance
<b>Grease Duct Enclosure System</b>	ASTM E2336	Pass
Section 16.1 - Non-Combustibility	ASTM E136	Pass
Section 16.2-Fire Resistance (wall)	ASTM E119	Pass
Section 16.3 - Durability Test	ASTM C518	Pass
Section 16.4 - Internal Fire Test	ASTM E2336	Pass
Section 16.5 - Fire Engulfment (duct)	ASTM E814/E119	Pass
ULC Grease Duct Test Protocol		Pass
Standard Methods of Fire Resistance Tests - Grease Duct Assemblies	CAN/ULC S144	Pass
Grease Duct Clearances	UL 1978	Pass
<b>Air Ventilation Duct Enclosure</b>	ISO 6944	Pass
<b>Surface Burning Characteristics</b>	ASTM E84	<25/50
<b>Thermal Resistance (R-value @ 75°F)</b>	ASTM C518	7.3 per layer
<b>Mold Growth</b>	ASTM C1338	ULE Validated
<b>Low VOCs</b>	CA Standard 01350	ULE Validated

### 6. Listings/Building Code Reports

Listed Uses	Agency	Listing	Layers
Grease Duct Enclosure per ASTM E2336 and AC101 (2006, 2009, 2012 IMC, NFPA 96, UMC, CMC)	UL	G18	2
	ICC-ES	ESR 2213	
ULC Grease Duct Test Protocol and CAN/ULC S144*	ULC	FRD 4, 7*	2
Grease Duct Insulation (2003 IMC)	OPL	TC/BI 120-01	1
Through Penetration FireStop System per ASTM E814, UL 1479	UL	See Figure 2	1 or 2
	ULC		
1- or 2-hour Ventilation Duct Enclosure per ISO 6944-1985	UL	HNLJ.V1, 19, 29	1
	ULC	FRD 3, 5, 6, 18	
3-hour Ventilation Duct Enclosure per ISO 6944-1985	UL	HNLJ.V2	2
Electrical Circuit Protective System	UL	FHIT.5	2

### 7. Storage

Thermal Ceramics FastWrap XL must be stored in a dry warehouse environment on pallets. Pallets should not be stacked.

### 8. Installation

Thermal Ceramics FastWrap XL shall be installed by a qualified contractor in accordance with manufacturer's instructions and laboratory design listings.

### Materials and Equipment

- Thermal Ceramics FastWrap XL blanket
- Aluminum foil tape
- Glass filament reinforced tape (optional)
- Carbon steel or stainless steel banding material, minimum 1/2" (13mm) wide, minimum 0.015" (0.4mm) thick, with steel banding clips
- Hand banding tensioner and crimping tool
- Minimum 12 gage (3mm) steel insulation pins; steel speed clips, minimum 1-1/2" (38mm) square or 1-1/2" (38mm) diameter, or equivalent sized cup-head pins;
- Capacitor discharge stud gun
- Thermal Ceramics FastDoor™ XL
- An approved firestop sealant

## FireMaster® FastWrap® XL



### General

Cut edges of the blanket shall be taped with aluminum foil tape to prevent exposed edges of the insulation absorbing grease and moisture in the event of a compromised grease duct joint or condensation. Overlaps and/or tightly butted joints are used to block heat transfer in the event of duct deformation resulting from thermal expansion. Filament tape is suggested to hold the blanket in place until steel banding or pinning is installed to permanently secure the blanket.

#### A. Installation on Grease Duct per ASTM E2336 and CAN/ULC S144 (Figure 1)

System requires two layers of insulation applied directly to the duct with tight butt joints at all seams on both layers. The first layer of insulation is cut to a length sufficient to wrap around the duct and provide a tight butt joint where the blanket ends meet. Adjacent blankets on the first layer are butted tightly together with longitudinal seams offset minimum 6" (150mm). The second layer of insulation is installed in the same method as the first layer, with seams between layers offset a minimum of 6" (150mm). Banding and/or pinning per Section D is used to permanently secure the insulation to the duct.

#### B. Installation on HVAC Duct per ISO 6944 (Figure 1)

System requires one layer of insulation applied directly to the duct with 3" (75mm) overlaps at all seams. The insulation is cut to a length sufficient to wrap around the duct and provide a 3" (75mm) overlap where the blanket ends meet. Adjacent blankets are installed to provide a minimum overlap of 3" (75mm). Banding and/or pinning per Section D is used to permanently secure the insulation to the duct.

#### C. 2 & 3 Sided Wrap Installation (Figure 4)

When space does not allow for a complete wrap applied to the duct on all four sides, the FastWrap XL is approved for 2 or 3 sided installations with mechanical attachment to a rated concrete or CMU assembly. (See Figure 4 for installation details.)

#### D. Mechanical Attachment Methods

- 1) Banding (Figure 1)** - Minimum 1/2" (13mm) wide carbon steel or stainless steel banding, 0.015" (0.4mm) thick, is placed around the entire perimeter of the insulated duct on maximum 10-1/2" (270mm) centers and 1-1/2" (38mm) from each blanket edge or 1-1/2" (38mm) from each collar edge when using the butt joint

and collar method. The banding is placed around the blanket and tightened to firmly hold the FastWrap XL in place against the duct, but not cause any cutting or damage to the blanket.

- 2) Pinning** - Pinning on all sides of the duct may be used as an alternative to banding. For ducts wider than 24" (610mm) pinning is required on the bottom of horizontal runs, or on one side of vertical runs (in addition to steel banding). When applicable, 12 Gage (0.4mm) steel pins are installed on 12" (305mm) centers along the width of the duct and 10-1/2" (270mm) centers along the length of the duct. Pins that extend beyond the outer blanket layer shall be turned down or the excessive length cut off to prevent sharp edges. Shoot through pins (cup head pins) may be used in conjunction with steel banding to prevent blanket sag.

#### E. Access Doors

- 1) FastDoor™ XL (Figure 3)** - FastDoor XL is a UL Listed, liquid tight duct cover panel supplied complete with a single layer insulation cover per UL Listing HNKT G18. The FastDoor XL is installed per included installation instructions. No field welding is required.
- 2) Field Fabricated Access Doors** - Each access door assembly has four threaded rods 1/4 inch (6mm) in diameter and 5" (127mm) in length, with one welded to each corner of the door opening. Hollow steel tubes, 4-1/2" (114mm) long are installed outside the access cover plate and over the threaded rods. Four 12 gage (3mm) and 4-1/2" (114mm) long steel insulation pins are welded to the access cover plate to allow for installation of the three layers of FastWrap XL. One layer of FastWrap XL is cut to approximately the same size as the access panel, and impaled over the insulation pins on the panel. A second layer of FastWrap XL is cut so as to overlap the first layer a minimum of 1-1/2" (38mm). It is essential that the first and second layer fit tightly against the surrounding wrap with no through openings. The third and outside layer should be cut to overlap the second insulation layer by a minimum of 1-1/2" (38mm). Minimum 1-1/2" (38mm) round or square insulation clips are installed on the insulation pins to secure the three layers of insulation to the access cover plate. All cut edges of the insulation shall be taped with minimum 3" (75mm) wide aluminum foil tape. Wing nuts and washers are installed on the four threaded rods, and tightened against the hollow steel tubes to seal the

## FireMaster® FastWrap® XL



access cover plate to the duct.

### F. Through Penetration Firestop System (Figure 2) -

When the duct penetrates a fire rated assembly an approved fire stop system must be employed. Figure 2 provides a complete list of UL / ULC firestop design listings which can be found in the Certifications Directory at [www.ul.com](http://www.ul.com) for US systems and [www.ulc.ca](http://www.ulc.ca) for Canadian systems. Prior to installing any firestop system the surfaces of all openings and penetrating items must be clean and dry. The FastWrap XL core blanket (or mineral wool where allowed by the firestop design listing) must be compressed into the annular space. The packing material must be recessed a minimum depth from the surface of the concrete or gypsum assembly. The recessed opening must be filled with a minimum thickness of an approved firestop sealant. The packing material type and compression, minimum recess (typically 1/4" (6mm)), and approved firestop sealant and thickness (typically 1/4" (6mm)) shall be as specified in an approved UL / ULC firestop design listing. When there is not sufficient annular space around the duct to run the FastWrap XL enclosure system continuous through the fire rated assembly, the enclosure may terminate above and below the floor/ceiling assembly or on either side of a wall assembly as shown in Figure 2. When this method is used, the FastWrap XL must be mechanically attached on either side of the fire rated assembly using one of the attachment methods described in Section D, spaced a maximum of 1-1/2" (38mm) from the fire rated assembly.

### G. Support Hanger Systems

**1) Grease ducts:** Trapeze support hangers shall be spaced on maximum 60 in. (1500 mm) centers. Hanger rods or straps shall be anchored with steel drop in or wedge expansion type masonry anchors. No additional protection is required for hangers and supports meeting the requirements of the Table below.

Hanger Cross Section	Maximum Perimeter, in (mm)	Trapeze Support (or equivalent Yield Strength), in (mm)
3/8 in (10 mm) threaded rod	148 (3759)	2 (51) x 2 (51) x 1/4 (6) in angle

**2) HVAC ducts:** Trapeze support hangers shall be spaced on maximum 60 in. (1500 mm) centers. Hanger rods or straps shall be anchored with steel drop in or wedge expansion type masonry anchors. No additional

protection is required for hangers and supports meeting the requirements of the Table below.

Hanger Cross Section	Max. Perimeter, in (mm)	Trapeze Support (or equivalent Yield Strength), in (mm)
1 in x 16 gage strap (25 mm x 1.5 gage strap)	100 (2540)	
1/4 in (6 mm) threaded rod	50 (1270)	1 1/2 (38) x 1 1/2 (38) x 3/16 (5) angle
3/8 in (10 mm) threaded rod	150 (3810)	1 1/2 (38) x 1 1/2 (38) x 3/16 (5) angle
1/2 in (12.7 mm) threaded rod	218 (5540)	2 (51) x 2 (51) x 1/4 (6) angle rod

### 9. Maintenance and Repair

No maintenance is required when installed in accordance with Thermal Ceramics (TC) installation instructions. If damage is limited to the foil facing, aluminum foil tape can be used to repair the foil facing. If an area of blanket is found to be damaged the following procedure must be incorporated. If the damaged area is larger than 8" (203mm) x 8" (203mm) the entire wrap section must be removed and replaced according to TC installation instructions. If the damaged area is small (less than 8" (203mm) x 8" (203mm)), the damaged area must be cut away and replaced with a new section 1" (25mm) larger in length and width than the cut out, such that the new section can be compressed tightly into the cut out area. All cut edges of the new section must be taped and sealed with aluminum foil tape. The new section must be held in place with either pinning or banding per TC installation instructions.

### 10. Limitations

Thermal Ceramics FireMaster FastWrap XL shall be installed in accordance with these installation instructions and appropriate laboratory design listings. The integrity of FastWrap XL systems is limited to the quality of the installation.

\* For personal protective equipment recommendations, please see SDS.

Thermal Ceramics, FireMaster, and FastWrap are trademarks of Morgan Advanced Materials. FireMaster products are manufactured by Thermal Ceramics and are distributed by authorized distributors.

FireMaster® FastWrap® XL



Grease and HVAC Duct Enclosure System  
1 or 2 Hour Shaft Alternative / Zero Clearance to Combustibles

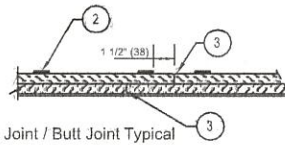
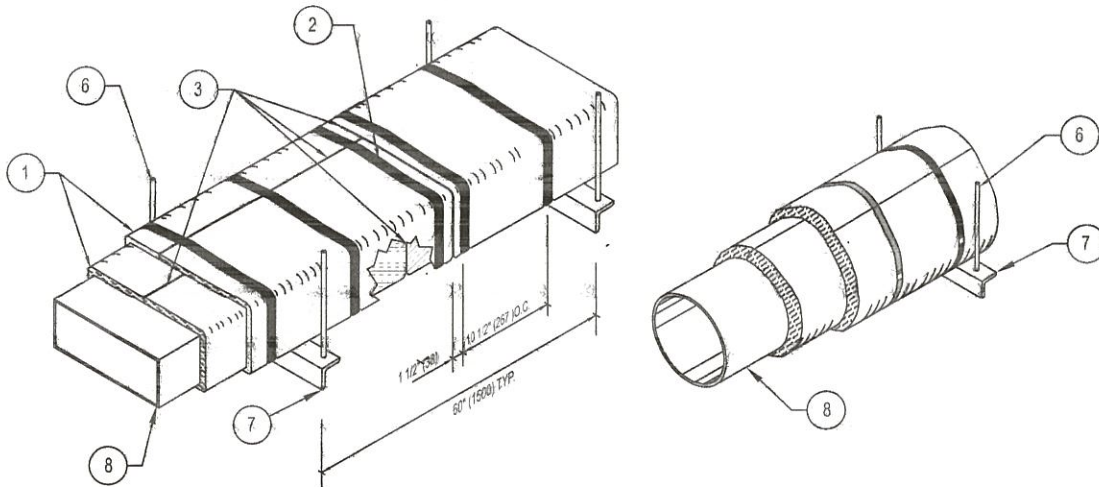

**TWO LAYER INSTALLATION (Grease Duct per ASTM E2336 and CAN/ULC S144)**

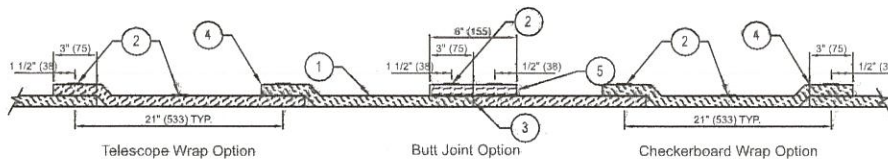

**SINGLE LAYER INSTALLATION OPTIONS (2-Hour rated HVAC Duct per UL HNLJ V-19)**

LEGEND	
1	Two Layers of XL Insulation for ASTM E2336 and CAN/ULC S144; Grease Duct Enclosures One Layer of XL Insulation for 2-Hour Air Ventilation Duct Enclosures
2	Steel banding minimum 1/2" (13) wide by 0.015" (0.4) thick.
3	Tight butt joints (no overlap) at perimeter and longitudinal joints, both layers for grease ducts
4	Min. 3" (75) overlap on perimeter and between adjacent blankets
5	Optional 6" XL collar
6	Hangers - size dependent weight of assembly (see datasheet Section G)
7	Trapeze Supports - size dependent on weight of assembly (see datasheet Section G)
8	Steel Rectangular or Round Duct (size, gage and construction dependent per Listed Design)

The integrity of Thermal Ceramics duct systems is limited to the quality of the installation.

XL001-10

FireMaster® FastWrap® XL



Commercial Kitchen Grease Duct Enclosure System  
Air Ventilation Duct Enclosure System  
Through Penetration Firestop Systems

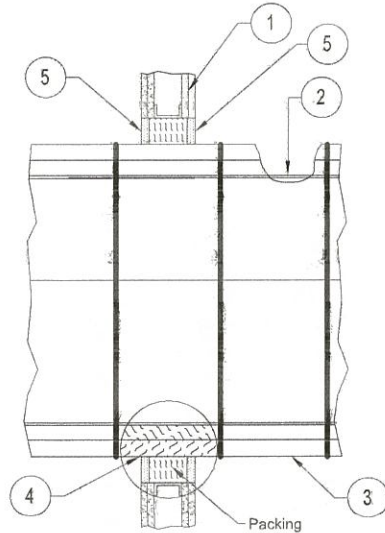

XL Insulation continuous through rated wall assembly

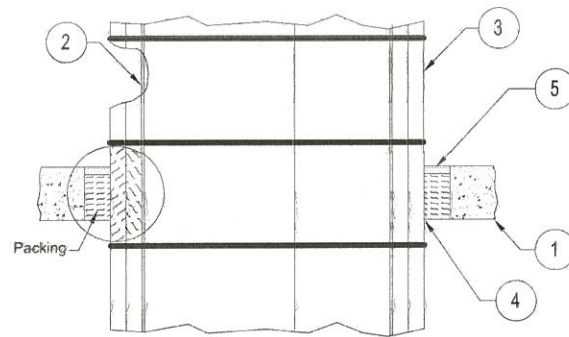

XL Insulation continuous through rated floor/ceiling assembly

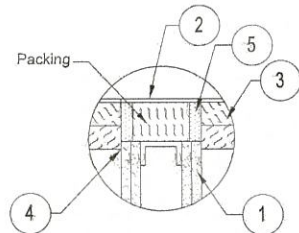

XL insulation terminated on both sides of the rated wall assembly

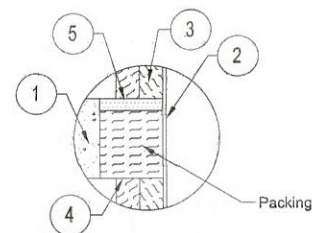

XL insulation terminated at the top and bottom surface of the floor/ceiling assembly

Firestop Designs per ASTM E814 / UL 1479 - Consult UL / ULC Directories for System Details						
UL Listing	F- & T-Rating	(1) Floor/Wall	(2) Penetrant	(3) Enclosure Per	(4) Termination	(5) Firestop Sealant Details
C-AJ-7012	2-hour	Concrete/CMU	84x24; 26 Ga Duct	V19; FRD3; 5; 18	wrap through	1/2 in; STI; Tremco
C-AJ-7014	3-hour	Concrete/CMU	84x24; 26 Ga Duct	V2;	wrap through	1/2 in; STI; Tremco
C-AJ-7019	1 or 2-hour	Concrete/CMU	84x24; 26 Ga Duct	V19; FRD3; 5, 18	terminate at	1/4 in; STI; Tremco
C-AJ-7021	2-hour	Concrete/CMU	49x24; 16 Ga Duct	G18; FRD4; 7	terminate at	1/4 in; STI; Tremco
C-AJ-7095	2-hour	Concrete/CMU	39x39; 22 Ga Duct	V19; FRD3; 5, 18	wrap through	1/4 in; STI Hilti; Rectorseal; Tremco
C-AJ-7098	2-hour	Concrete/CMU	49x24; 16 Ga Duct	G18; FRD4; 7	wrap through	1/4 in; STI; Hilti; Rectorseal; Tremco
F-C-7036	1 or 2-hour	Wood/Gyp Floor	24x12; 16 Ga Duct	G18; FRD4; 7	wrap through	1/4 in; STI; Hilti; Rectorseal; Tremco
F-C-7055	1-hour	Wood/Gyp Floor	4 Dia; 30 Ga Duct	V29; FRD28	wrap through	1/4 in; STI
W-J-7086	2-hour	Concrete/CMU Wall	100x100; 26 Ga Duct	V19; FRD3; 5; 18	terminate at	1/4 in; STI
W-L-7121	1 or 2-hour	Gyp Wall	30x30; 16 Ga Duct	G18; FRD4; 7	wrap through	1/4 in; STI; Hilti; Rectorseal; Tremco
W-L-7145	1 or 2-hour	Gyp Wall	100x100; 26 Ga Duct	V19; FRD3; 5; 18	terminate at	5/8 in; STI

The integrity of Thermal Ceramics duct systems is limited to the quality of the installation.  
XL003-5



Tag: **MAU-1**  
 Project Number: 1735  
 Project Name: **32646**  
 Representative: Taz Roopnarine  
 Location:

Comments:

**Unit Information**      Package Unit - DOAS

Model:	<b>PROA</b>	Unit Length:	in	Weight Operating:	lb
Size:	<b>84 B1</b>	Unit Width:	in	<b>Note: Dimensions and weight are for base unit only and do not include Exhaust and ECW options. See catalog for dimensions and weights.</b>	
Quantity:	<b>1</b>	Unit Height:	in		

**Design Conditions**

Supply Airflow:	<b>1540</b> CFM	Ambient Air DB:	<b>87.0</b> F
Outside Airflow:	<b>1540</b> CFM		

**Cooling Performance**

Gross Total Capacity:	<b>86.5</b> MBh	Evaporator Face Area:	<b>4.72</b> sq ft
Gross Sensible Capacity:	<b>54.5</b> MBh	Evaporator Rows:	<b>6</b>
Net Total Capacity:	<b>82.9</b> MBh	Evaporator FPI:	<b>12</b>
Net Sensible Capacity:	<b>50.9</b> MBh	Condenser Face Area:	<b>13.5</b> sq ft
Entering Air DB / WB (Coil):	<b>87.0 / 72.0</b> F	Condenser Rows:	<b>3</b>
Leaving Air DB / WB (Coil):	<b>55.1 / 55.0</b> F	Condenser FPI:	<b>12</b>
Leaving Air DB / WB (Subcooling):	<b>/</b> F	Air Velocity:	<b>326</b> fpm
Leaving Air DB / WB (Max. Reheat):	<b>85.3 / 66.0</b> F	Cooling Coil Air PD:	<b>0.42</b> in H2O
Leaving Air DB / WB (Unit):	<b>87.5 / 66.7</b> F		
EER:	<b>13.2</b>		
Watts:	<b>6269.0 / 6269.0</b>		

**Heating Performance**

Heat Type:	<b>Gas</b>	Entering Air DB:	<b>1.0</b> F
Input Capacity:	<b>150.0</b> MBh	Leaving Air DB:	<b>73.2</b> F
Output Capacity:	<b>120.0</b> MBh	Heating Coil Air PD:	<b>in H2O</b>



Comments:

## Supply Fan    GKHM 450

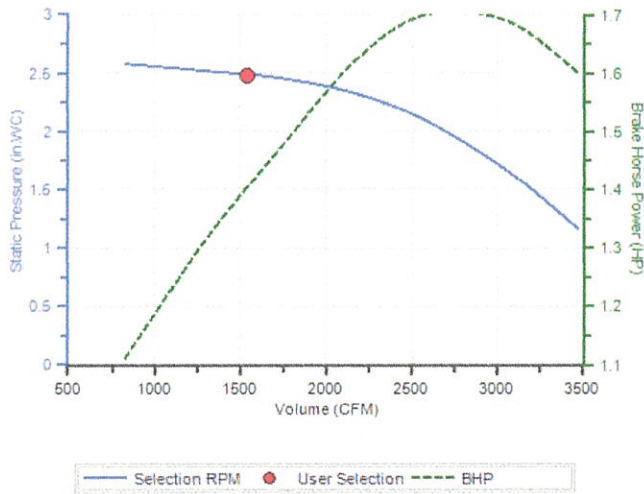

### Supply Pressure Drop Summary

External Static Pressure:	1.00	in H2O
Internal Pressure Drop:	1.48	in H2O
<b>Total Static Pressure:</b>	<b>2.48</b>	<b>in H2O</b>

### Supply Fan Conditions

Fan Motor BHP:	1.40	BHP
Fan RPM:	1550	RPM



Tag: **MAU-1**  
Project Number: 1735  
Project Name: **32646**  
Representative: Taz Roopnarine  
Location:

Comments:

---

### Unit Electrical Data

Unit Voltage-Ph-Hz: **208-3-60**  
Unit Amps - FLA: **33.5** Amps  
Min Circuit Ampacity - MCA: **39.3** Amps  
Maximum Fuse Size - MFS: **60** Amps

### Motors

<u>Name/Type</u>	<u>Fan Service</u>	<u>Qty</u>	<u>HP (ea.)</u>	<u>FLA (ea.)</u>	<u>RLA (ea.)</u>	<u>LRA (ea.)</u>
<b>Digital Scroll</b>		<b>1</b>			<b>23.2</b>	<b>164.0</b>
<b>ECM -450</b>	<b>Supply</b>	<b>1</b>	<b>3.8</b>	<b>7.5</b>		
<b>Condenser Fan Motor</b>	<b>Condenser</b>	<b>1</b>	<b>1</b>	<b>2.8</b>		

### Notes

1. See project schedule for selected options for this selection.
2. See catalog for dimensions and weight.
3. For dual point power connections (electric heat), Unit Electrical Data does not include electric heat power requirements.

Comments:

## Terms of Use

These Terms of Use are a contract between you and Addison. By using any electronic media we produce for equipment sizing, design, selection and pricing ("Electronic Media"), you are agreeing to be bound by the following terms and conditions ("Terms of Use"). If you do not agree to these Terms of Use, do not use any Electronic Media we produce; instead, promptly return it to Addison. This contract is effective until terminated by Addison. This contract will be terminated immediately and without notice in the event that you fail to comply with any term or condition hereof.

### 1. Ownership of Content.

The Electronic Media is owned by Addison. The media can be in any form such as an actual CD that has to be installed or electronic file that has to be downloaded. The visual interfaces, graphics, design, compilation, information, computer code (including source code or object code), products, software, services, and all other elements of the Electronic Media (the "Materials") are protected by United States copyright, trade dress, patent, and trademark laws, international conventions, and all other relevant intellectual property and proprietary rights, and applicable laws. All Materials contained on the Electronic Media are the property of Addison or its subsidiaries or affiliated companies and/or third-party licensors. All trademarks, logos and service marks displayed on the Electronic Media, whether registered or unregistered, are owned exclusively by Addison or its affiliates and/or other third parties. Nothing contained in these Terms of Use, nor your use of the Materials, shall be construed as granting you any license or right in or to any trademark, logo, or service mark. Addison reserves all rights not expressly granted in this Terms of Use.

### 2. License

Addison hereby grants you a nontransferable, nonexclusive license to use the Materials contained on the Electronic Media solely for your information and own personal, noncommercial use, to be used with a single computer at a single location. You may download and/or print a single copy of any of the Materials contained herein for your personal use; however, you shall not otherwise reproduce, display, publish, distribute, sell, license, or modify the Materials or incorporate the Materials into other documents, Electronic Media, or publications. This license is not a sale of the electronic Media or any copy thereof. Addison retains the title and ownership of the Electronic Media and all copies, regardless of the form or media on or in which the original or any copy may exist. You may not copy, encourage or allow copying of the Electronic Media, except when you make a single copy for archival purposes only. You may be held legally responsible for any copyright infringement which is caused or encouraged by your failure to abide by this Terms of Use. You may not transfer, convey, rent, sublicense, or otherwise distribute the Electronic Media or accompanying documentation, or any rights therein to any person or entity. Any attempt to so distribute the Electronic Media or accompanying documentation shall be void.

### 3. Modification of these Terms of Use; Termination.

Addison reserves the right, at our discretion, to change, modify, add, or remove portions of these Terms of Use at any time.

### 4. Disclaimer of Warranties

The Electronic Media and Materials may contain inaccuracies and/or typographical errors. The Electronic Media and Materials are provided to you on an "AS IS" basis. ADDISON DISCLAIMS ANY AND ALL WARRANTIES EXPRESSED, STATUTORY OR IMPLIED WITH RESPECT TO THE ELECTRONIC MEDIA OR THE MATERIALS, INCLUDING BUT NOT LIMITED TO ANY IMPLIED WARRANTIES OF MERCHANTABILITY, NON-INFRINGEMENT OR THIRD PARTY RIGHTS AND FITNESS FOR A PARTICULAR PURPOSE.

### 5. Limitation of Liability and Damages

Addison does not warrant, guarantee or make any representations regarding the use or the results of the Electronic Media in terms of its correctness, accuracy, performance, reliability or otherwise. The entire risk as to the results and performance of the Electronic Media is assumed by you. This Electronic Media is merely a tool to aid you, the results of which should be checked against your own calculations. Addison makes no warranties, express or implied including without limitation the implied warranties of merchantability and fitness for a particular purpose. TO THE FULLEST EXTENT ALLOWED BY APPLICABLE LAW, ADDISON HEREBY DISCLAIMS, AND IN NO EVENT SHALL ADDISON OR ANY PARTY INVOLVED IN CREATING OR PRODUCING THE ELECTRONIC MEDIA, BE LIABLE FOR ANY DIRECT, INDIRECT OR CONSEQUENTIAL DAMAGES RESULTING FROM LOSS RELATED TO THE USE OF THE ELECTRONIC MEDIA OR ANY MATERIALS, WHETHER IN AN ACTION OF CONTRACT, NEGLIGENCE, OR OTHER TORTUOUS ACTION, EVEN IF ADDISON HAS BEEN ADVISED OF THE POSSIBILITY OF SUCH DAMAGES, INCLUDING DAMAGES FOR LOSS OF BUSINESS PROFITS, BUSINESS INTERRUPTIONS, LOSS OF BUSINESS INFORMATION AND THE LIKE, ARISING OUT THE USE OR LIABILITY TO USE THE ELECTRONIC MEDIA. FURTHERMORE, ADDISON SHALL NOT BE LIABLE FOR ANY DAMAGES TO YOUR PROPERTY OR LOSS OF DATA THAT RESULTS FROM THE DOWNLOAD OR USE OF THE MATERIALS.

### 6. Indemnification

You agree to indemnify, save, and hold ADDISON, its affiliated companies, contractors, employees, agents and its third-party suppliers, licensors, and partners harmless from any claims, losses, damages, liabilities, including legal fees and expenses, arising out of your use or misuse of the ELECTRONIC MEDIA, any violation by you of these Terms of Use, or any breach of the representations, warranties, and covenants made by you herein. ADDISON reserves the right, at your expense, to assume the exclusive defense and control of any matter for which you are required to indemnify ADDISON, and you agree to cooperate with ADDISON's defense of these claims. ADDISON will use reasonable efforts to notify you of any such claim, action, or proceeding upon becoming aware of it.

### 7. Miscellaneous

These Terms of Use constitute the entire agreement between you and ADDISON and govern your use of the ELECTRONIC MEDIA, superseding any prior agreements between you and ADDISON (including, but not limited to, any prior versions of the Terms of Use) and any prior representations by ADDISON. These Terms of Use shall be governed by and construed in accordance with the laws of the State of New York, without regard to conflicts of law principles. The failure of ADDISON to exercise or enforce any right or provision of the Terms of Use shall not constitute a waiver of such right or provision. If any provision of the Terms of Use is found by a court of competent jurisdiction to be invalid, the parties nevertheless agree that the court should endeavor to give effect to the parties' intentions as reflected in the provision, and the other provisions of the Terms of Use remain in full force and effect. You agree that regardless of any statute or law to the contrary, any claim or cause of



Tag: **MAU-1**  
Project Number: 1735  
Project Name: **32646**  
Representative: Taz Roopnarine  
Location:

Comments:

---

action brought against ADDISON and its subsidiaries, affiliates, officers, agents, co-branders or other partners and employees, arising out of or related to use of the ELECTRONIC MEDIA or the Terms of Use must be filed within one (1) year after such claim or cause of action arose or be forever barred. The section titles in the Terms of Use are for convenience only and have no legal or contractual effect.

8. In the Event of Merger or Sale

In the event that ADDISON is acquired by or merged with a third-party entity, we reserve the right, in any of these circumstances, to transfer or assign the information that we have collected from Users as part of such merger, acquisition, sale, or other change of control.

9. ADDISON Contact Information:

Please contact ADDISON with any questions or comments about this Terms of Use at: "Contact Us" <http://www.addison-hvac.com/>.

## FX

### Roof Mounted Upblast Spun Aluminum Exhaust Fan

#### Product Main

FX

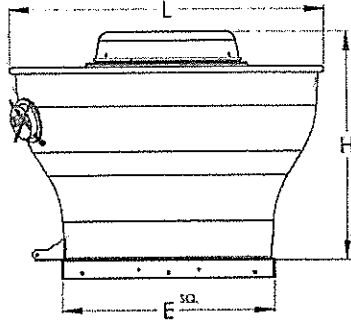

- AMCA Air & Sound
- UL Listed
- Two (2) patented wheel designs
- Unique internal bracing design transfers weight directly to curb; no spun parts supply structural support
- Welded curb cap available as either galvanized or aluminum
- Popular direct drive sizes use multi-speed motors for maximum flexibility
- Plug-Disconnect and pre-wired junction box (1-speed ODP motors up to 3/4 HP)

E sq	H	L	Ro	Weight
20.5	22.375	30.75	16	73

#### Fan Performance

Performance						Motor Information		
Qty	Model	Volume (CFM)	S.P. (w.c)	RPM	BHP/Watts	Motor HP	Volt/Ph/Hz	Enclosure
1	FX16Q2GP	1390	1.50	1667	0.68	0.75 - 3/4 HP	208V 1/1 60	O - ODP

#### SOUND POWER

OCTAVE POWER CENTER FREQUENCY (hz)								LWA	Dba	Sones
63	125	250	500	1000	2000	4000	8000			
72	81	81	72	66	65	61	55	76	64.3	13.3

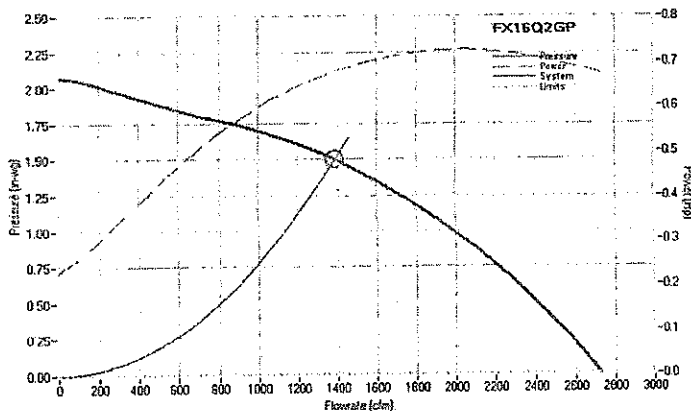

#### ACCESSORIES

- EC Motor: G - ECM with Mntd Pot
- Motor RPM: 1 - Single Speed
- Efficiency: S - Standard
- Hinged Sub-Base: H - Hinged Sub-Base
- Aluminum Base: A - Aluminum Base
- Overload Protection: P - Protected
- Disconnect Switch: 3R - Nema 3R



# SFG18

## Prefabricated Heavy-gauge steel Roof Curbs

**Product Image**

**SFG18**

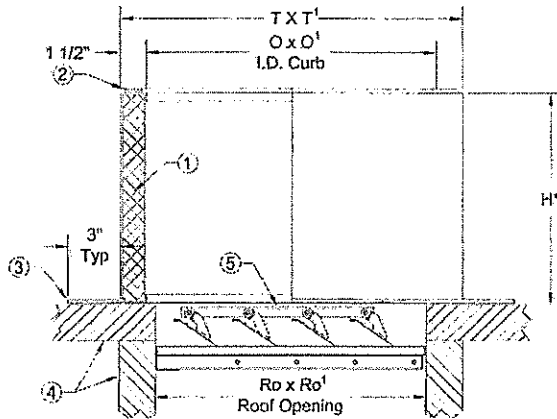

Prefabricated Roof Curbs shall be Unibeam or Self-Flashing supplied by PennBarry, Plano, Texas 75074.

Heavy-gauge steel with welded corner seams and neoprene gasket (Self-Flashing) top surface is provided for fan installation and/or roofing paper. Flat (single or double pitch optional) curb fastening flange shall be Cantless. Optional vented sides available without fiberglass insulation.

T	T1	O	O1	H	RO	RO1
20	20	17	17	18	16	16

**Options or Accessories Listing**

- Curb Parent** FX16Q2
- Roof Slope** 0 - None
- Curb Liner** 0 - None
- Damper Hold Plate** 0 - None
- Curb Gasket** 0 - None

**Product Notes**

1. 1 1/2" Rigid Fiberglass Insulation
2. Neoprene gasket
3. Curb Fastening Flange
4. Roof Structure - By Others
5. Backdraft Damper - Optional

**Schedule**

ID	Quantity	Tag	Curb Dim1	Curb Dim2	Roof Pitch Dim by 12
1	1	EF-R1	19	19	0

**EXHAUST FAN INFORMATION -- Job#2880103**

FAN UNIT NO.	TAG	FAN UNIT MODEL #	CFM	ESP.	RPM	HP.	B.H.P.	φ	VOLT	FLA	DISCHARGE VELOCITY	WEIGHT (LBS.)	SDNES
1		CASRE183DHP	1600	2.250	1455	2.000	1.2670	1	208	10.3	927 FPM	384	21

**FAN OPTIONS**

FAN UNIT NO.	TAG	OPTION (Qty. - Descr.)
1		1 - Full Crating For Exhaust Fans
		1 - Utility Set Grease Cup
		1 - 3 Year Extended Motor Warranty
		1 - Extra Set of Belts
		1 - Fan Base Ceramic Seal - For Grease Ducts
	1 - RE18 - Discharge Extension Assembly With Hardware.	

**FAN ACCESSORIES**

FAN UNIT NO.	TAG	EXHAUST	SUPPLY
1		GREASE CUP	GRAVITY DAMPER
		WALL MOUNT	MOTORIZED DAMPER
		DISCHARGE	WALL MOUNT

**CURB ASSEMBLIES**

DN FAN NO.	WEIGHT	ITEM	SIZE
1	22 LBS	Exhaust Adaptor	From 20.500"sq To 26.500"sq x 9.000"PH

**FAN SOUND INFORMATION**

FAN UNIT NO.	MOTOR	RPM	LVA	SDNES	21	72.4	5	83.5	88.2	89.9	78.3	72.7	68.4	65.3	59.5
1	Exhaust	1455	83.9	21	72.4	5	83.5	88.2	89.9	78.3	72.7	68.4	65.3	59.5	

JOB Joe's Fan  
 LOCATION PORTLAND, ME.  
 DATE 1/6/2017  
 DWG # 1  
 REV.

**CAPTIVEAIRE**



JOB # 2880103  
 DRAWN BY BFC-21  
 SCALE 3/8" = 1'-0"

FAN #1 CASRE18BDHP - EXHAUST FAN

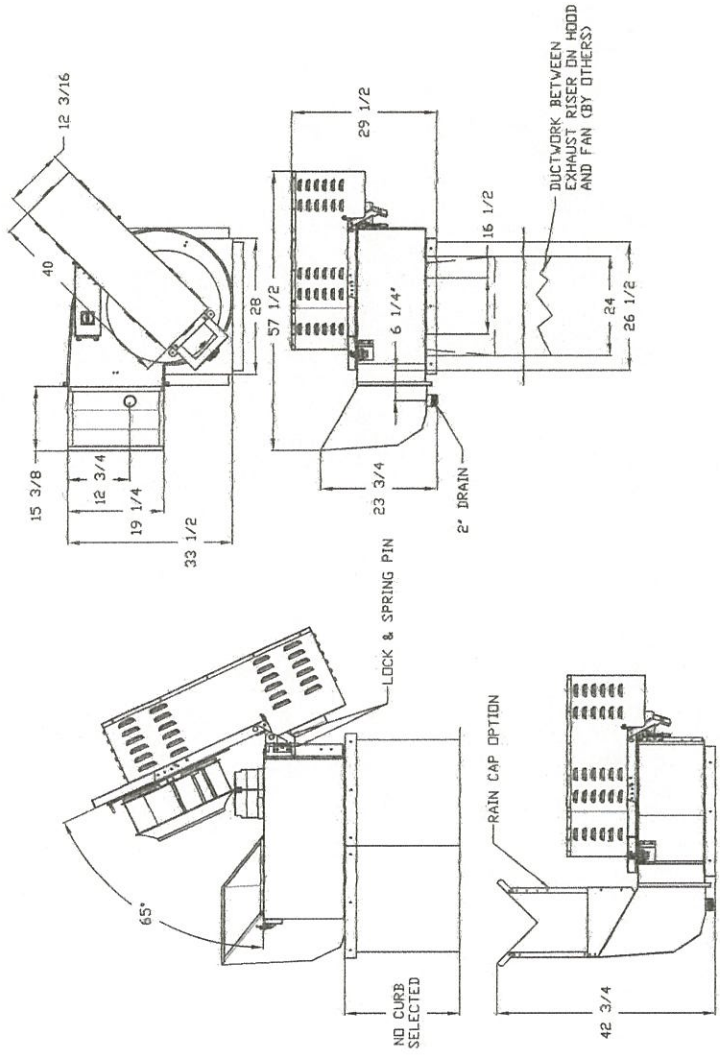

**FEATURES:**

- ROOF MOUNTED FANS
- RESTAURANT MODEL
- UL762
- HIGH HEAT OPERATION DIRECT DRIVE 300°F (149°C)
- HIGH HEAT OPERATION BELT DRIVE 500°F (260°C)
- HEAT SLINGER
- GREASE CLASSIFICATION TESTING
- TILT OUT WHEEL
- LOCKING PIN FOR POWER PACK
- MOTOR WEATHER COVER
- INTERLOCKED DISCONNECT SWITCH

NORMAL TEMPERATURE TEST BELT DRIVE EXHAUST FAN MUST OPERATE CONTINUOUSLY UNTIL EXHAUSTING AIR AT 500°F (260°C) UNTIL ALL FAN PARTS HAVE REACHED THERMAL EQUILIBRIUM, AND WITHOUT ANY DETERIORATING EFFECTS TO THE FAN WHICH WOULD CAUSE UNSAFE OPERATION.

ABNORMAL FLARE-UP TEST BELT & DIRECT DRIVE EXHAUST FAN MUST OPERATE CONTINUOUSLY WHILE EXHAUSTING BURNING GREASE VAPORS AT 600°F (316°C) FOR A PERIOD OF 15 MINUTES WITHOUT THE FAN BECOMING DAMAGED TO ANY EXTENT THAT COULD CAUSE AN UNSAFE CONDITION.

**OPTIONS:**

- FULL CRATING FOR EXHAUST FANS
- UTILITY SET GREASE CUP
- 3 YEAR EXTENDED MOTOR WARRANTY
- EXTRA SET OF BELTS
- FAN BASE CERAMIC SEAL - FOR GREASE DUCTS
- RE18 - DISCHARGE EXTENSION ASSEMBLY WITH HARDWARE.





# CAPTIVEAIRE

JOB Joe's Fan  
 LOCATION PORTLAND, ME,  
 DATE 1/6/2017  
 DWG # 2  
 REV.

JOB # 2880103  
 DRAWN BY BFC-21  
 SCALE 3/8" = 1'-0"



FAN#1 - EXHAUST PERFORMANCE CURVES.

1600 CFM, 2.25 SP @ 1455 RPM and 1.267 BHP at 97 feet and 70 deg F.  
 \* Please note that these curves were adjusted for job specific temperature and altitude.

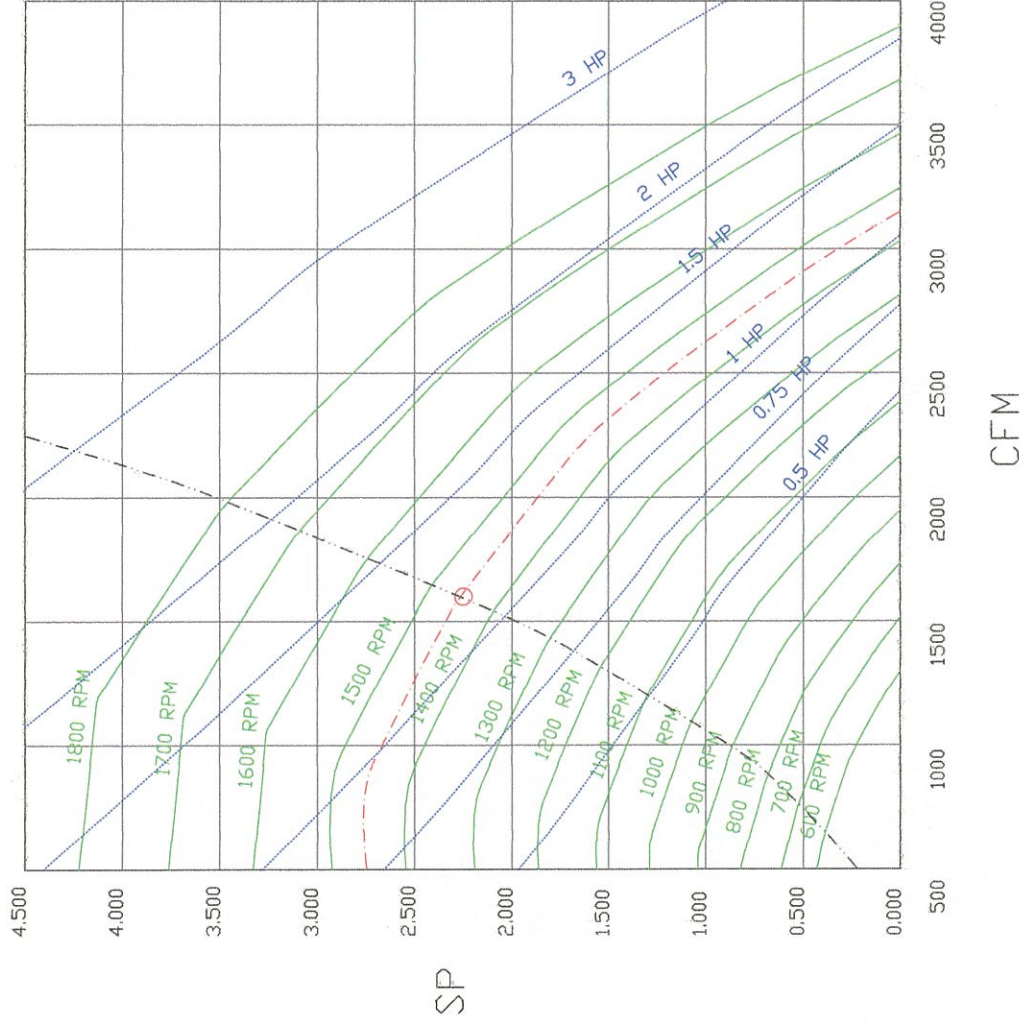

JOB Joe's Fan	LOCATION PORTLAND, ME.	JOB # 2880103
DATE 1/6/2017	DWG # 3	DRAWN BY BFC-21
REV.	SCALE 3/8" = 1'-0"	

**CAPTIVEAIRE**



Exhaust Fan Wiring

JOB 2880103 - Joe's Fan

DRAWING NUMBER EXH2880103-1

SHIP DATE 1/6/2017

MODEL CASRE18BDHP

Installed Options

1  
2  
3  
4  
5  
6  
7  
8  
9  
10  
11  
12  
13  
14  
15  
16  
17  
18  
19  
20  
21  
22  
23

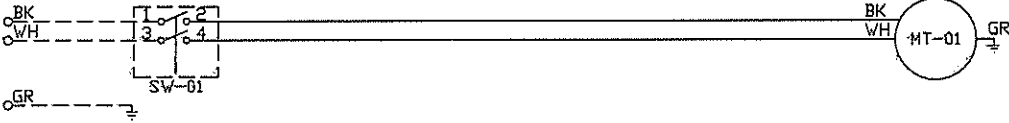

Component Identification		
Label	Description	Location
MT-01	Fan Motor	[28]
SW-01	Main disconnect switch	[21]

**MOTOR INFO**  
EXHAUST 2HP-208V-1P-10.3FLA

**ELECTRICAL INFORMATION**  
MOTOR/CTRL MCA: 12.9A  
MOTOR/CTRL MOP: 20A

**NOTES**  
---- DENOTES FIELD WIRING  
---- DENOTES INTERNAL WIRING

**WIRE COLOR**  
BK - BLACK YW - YELLOW  
BL - BLUE GR - GREEN  
BR - BROWN GY - GRAY  
GR - ORANGE PR - PURPLE  
RD - RED PK - PINK  
WH - WHITE