

STORM DRAIN APPURTENANCE SCHEDULE				
STRUCTURE	TYPE/DIA.	RIM	INV. IN / DIA. (FROM)	INV. OUT / DIA. (TO)
CB-1	4' TYP. CB (SEE DETAIL)	141.14	136.02 / 8" (DMH-1)	135.77 / 12" (BRACKETT ST.)
DMH-1	24" NYLOPLAST DRAIN BASIN	142.25	137.92 / 8" (ROOF DRAINS)	137.82 / 8" (CB-1)

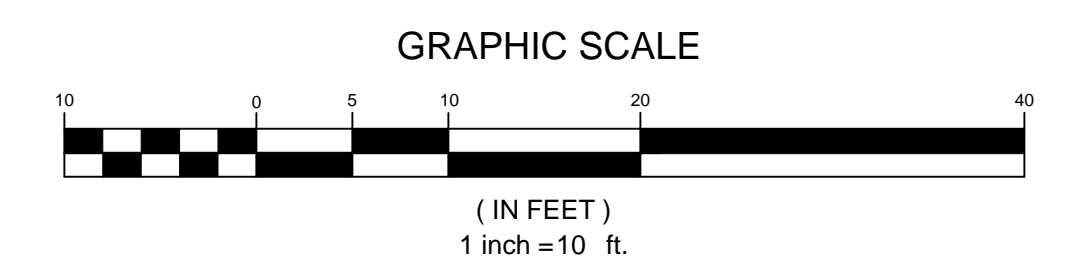

PRELIMINARY - NOT FOR CONSTRUCTION

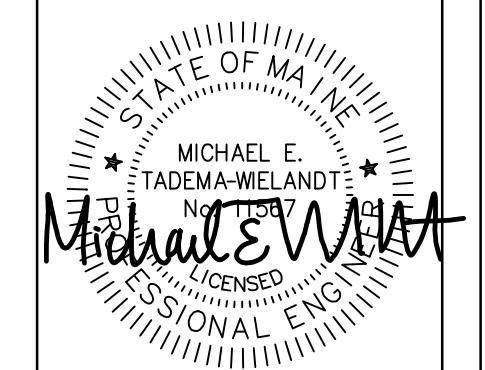
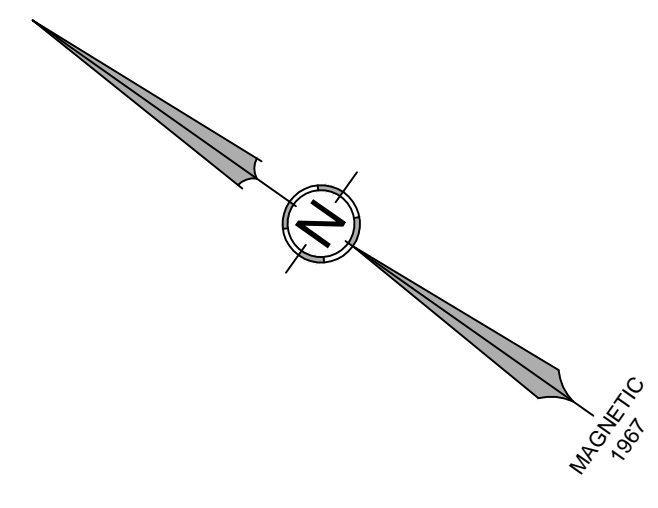

P.E. MICHAEL E. TADEAMA-WIELANDT
DATE: 9-13-2017

NO.	DATE	REVISIONS
1	4-25-2017	MTW APPD
2	8-7-2017	MTW REVIEW
3	8-29-2017	MTW REVIEW
4	9-13-2017	MTW REVIEW

965 CONGRESS STREET
SUITE 310
PORTLAND, ME 04102

P.O. BOX 339
111 ELDERBERRY LANE
NEW GLOUCESTER, ME 04260

OFFICE: (207) 926-5111 FAX: (207) 221-1317
www.terradynconsultants.com

TERRADYN CONSULTANTS, LLC
Civil Engineering - Land Planning - Stormwater Design - Environmental Permitting

SHEET DESCRIPTION
ONEJOY PLACE
1 JOY PLACE, PORTLAND, MAINE 04102

GRADING, DRAINAGE & EROSION CONTROL PLAN

PREPARED FOR
ONEJOY PLACE, LLC
C/O RENEWAL HOUSING ASSOCIATES, LLC
2 UNION STREET, 5TH FLOOR
PORTLAND, MAINE 04101

DATE: 3/7/2017
SCALE: 1" = 10'
DESIGNED: MTW
JOB NO.: 1704
FILE: 1704-BASE.DWG
SHEET **C-4.0**