

DISPLAY THIS CARD ON PRINCIPAL FRONTAGE OF WORK

CITY OF PORTLAND

BUILDING DEPARTMENT

PERMIT

Permit Number: 041425

Application has been abandoned + IS EXPIRED

Please Read Application And Notes, If Any, Attached

This is to certify that Shalom House Inc / Larry Ha

has permission to replace stair supports and reinforcement porch

AT 130 Park St L 045 A010001

provided that the person or persons, firm or corporation accepting this permit shall comply with all of the provisions of the Statutes of Maine and of the Ordinances of the City of Portland regulating the construction, maintenance and use of buildings and structures, and of the application on file in this department.

Apply to Public Works for street line and grade if nature of work requires such information.

Notification of inspection must be given and when permission is procured before this building or part thereof is occupied or closed-in. **HEAR NOTICE IS REQUIRED.**

A certificate of occupancy must be procured by owner before this building or part thereof is occupied.

1/22/08

OTHER REQUIRED APPROVALS

Fire Dept. *[Signature]*
Health Dept. _____
Appeal Board _____
Other _____

Department Name

Director - Building & Inspection Services

PENALTY FOR REMOVING THIS CARD

City of Portland, Maine - Building or Use Permit Application

389 Congress Street, 04101 Tel: (207) 874-8703, Fax: (207) 874-8716

Permit No: 04-1425	Issue Date:	CBL: 045 A010001
-----------------------	-------------	---------------------

Location of Construction: 130 Park St	Owner Name: Shalom House Inc	Owner Address: Po Box 560	Phone:
Business Name:	Contractor Name: Larry Hall	Contractor Address: P.O. Box 9715-168 Portland	Phone: 2077717979
Lessee/Buyer's Name	Phone:	Permit Type: Alterations - Commercial	Zone: B3

Past Use: commercial Group Home	Proposed Use: commercial replace stair supports and reinforcement of porch beam	Permit Fee: \$30.00	Cost of Work: \$4,000.00	CEO District: 2
<p><i>LEGAL USE: Group Home</i></p>		FIRE DEPT: <input checked="" type="checkbox"/> Approved <input type="checkbox"/> Denied	INSPECTION: Use Group: Type:	

Proposed Project Description: replace stair supports and reinforcement of porch beam	Signature: <i>[Signature]</i>	Signature:
<p><i>Permit Application has been abandoned + is expired</i></p>	PEDESTRIAN ACTIVITIES DISTRICT (P.A.D.)	
	Action: <input type="checkbox"/> Approved <input type="checkbox"/> Approved w/Conditions <input type="checkbox"/> Denied	
	Signature:	Date:

Permit Taken By: dmartin	Date Applied For: 09/23/2004	1/22/08 Zoning Approval
-----------------------------	---------------------------------	--------------------------------

- This permit application does not preclude the Applicant(s) from meeting applicable State and Federal Rules.
- Building permits do not include plumbing, septic or electrical work.
- Building permits are void if work is not started within six (6) months of the date of issuance. False information may invalidate a building permit and stop all work..

Special Zone or Reviews <input type="checkbox"/> Shoreland <input type="checkbox"/> Wetland <input type="checkbox"/> Flood Zone <input type="checkbox"/> Subdivision <input type="checkbox"/> Site Plan Maj <input type="checkbox"/> Minor <input type="checkbox"/> MM <input type="checkbox"/> Date: <i>10/16/04</i>	Zoning Appeal <input type="checkbox"/> Variance <input type="checkbox"/> Miscellaneous <input type="checkbox"/> Conditional Use <input type="checkbox"/> Interpretation <input type="checkbox"/> Approved <input type="checkbox"/> Denied Date:	Historic Preservation <input type="checkbox"/> Not in District or Landmark <input type="checkbox"/> Does Not Require Review <input type="checkbox"/> Requires Review <input type="checkbox"/> Approved <input type="checkbox"/> Approved w/Conditions <input type="checkbox"/> Denied Date: <i>TE previous</i> <p><i>SHALL BE NO CHANGE</i></p> <p><i>Historic Approvals - still enforce</i></p>
---	---	---

CERTIFICATION

I hereby certify that I am the owner of record of the named property, or that the proposed work is authorized by the owner of record and that I have been authorized by the owner to make this application as his authorized agent and I agree to conform to all applicable laws of this jurisdiction. In addition, if a permit for work described in the application is issued, I certify that the code official's authorized representative shall have the authority to enter all areas covered by such permit at any reasonable hour to enforce the provision of the code(s) applicable to such permit.

SIGNATURE OF APPLICANT	ADDRESS	DATE	PHONE
RESPONSIBLE PERSON IN CHARGE OF WORK, TITLE		DATE	PHONE

SEP 3 2 2004

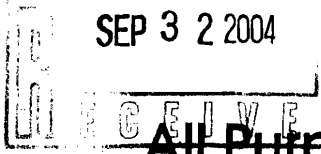

All Purpose Building Permit Application

If you or the property owner owes real estate or personal property taxes or user charges on any property within the City, payment arrangements must be made before permits of any kind are accepted.

Location/Address of Construction: <u>130 Pa Street Portland</u>		
Total Square Footage of Proposed Structure <u>140</u> ^{Stairs existing} / <u>154</u> ^{Porch existing}	Square Footage of Lot <u>4500</u>	
Tax Assessor's Chart, Block & Lot Chart# <u>045</u> Block# <u>A</u> Lot# <u>010</u>	Owner: <u>Shalom House Inc</u>	Telephone: <u>874-1080</u>
Lessee/Buyer's Name (if Applicable) <u>N/A</u>	Applicant name, address & telephone:	Cost Of Work: \$ <u>4000-</u> Fee: \$ <u>30.00</u> <u>ISSUE of Permit</u>
Current use: <u>Group Home</u>		
If the location is currently vacant, what was prior use: <u>N/A</u>		
Approximately how long has it been vacant: <u>N/A</u>		
Proposed use: <u>Same as current</u>		
Project description: <u>Replacement of Stair Support Reinforcement of Porch beam</u>		
Contractor's name, address & telephone: <u>Larry W Hall 771-7979 PO Box 9715-602 Portland ME 04104</u>		
Who should we contact when the permit is ready: <u>Norman F Mazer Jr Property Mgr PO Box 560 Portland ME 04112</u>		
Mailing address: <u>400 Congress St. Portland ME 04101</u>		
We will contact you by phone when the permit is ready. You must come in and pick up the permit and review the requirements before starting any work, with a Plan Reviewer. A stop work order will be issued and a \$100.00 fee if any work starts before the permit is picked up. PHONE: <u>874-1080</u> <u>X 119</u>		

IF THE REQUIRED INFORMATION IS NOT INCLUDED IN THE SUBMISSIONS THE PERMIT WILL BE AUTOMATICALLY DENIED AT THE DISCRETION OF THE BUILDING/PLANNING DEPARTMENT, WE MAY REQUIRE ADDITIONAL INFORMATION IN ORDER TO APPROVE THIS PERMIT.

I hereby certify that I am the Owner of record of the named property, or that the owner of record authorizes the proposed work and that I have been authorized by the owner to make this application as his/her authorized agent. I agree to conform to all applicable laws of this jurisdiction. In addition, if a permit for work described in this application is issued, I certify that the Code Official's authorized representative shall have the authority to enter all areas covered by this permit at any reasonable hour to enforce the provisions of the codes applicable to this permit.

Signature of applicant:	Date:
-------------------------	-------

This is NOT a permit, you may not commence ANY work until the permit is issued. If you are in a Historic District you may be subject to additional permitting and fees with the Planning Department on the 4th floor of City Hall

DISPLAY THIS CARD ON PRINCIPAL FRONTAGE OF WORK CITY OF PORTLAND

Please Read
Application And
Notes, If Any,
Attached

BUILDING DEPARTMENT

PERMIT

Permit Number: 030389

This is to certify that Shalom House Inc /Larry Ha
has permission to Replace beam underneath portion on side building
AT 130 Park St 045 A010001

provided that the person or persons, firm or corporation accepting this permit shall comply with all of the provisions of the Statutes of Maine and of the ordinances of the City of Portland regulating the construction, maintenance and use of buildings and structures, and of the application on file in this department.

Apply to Public Works for street line and grade if nature of work requires such information.

Notification of inspection must be given and when permission is procured before this building or part thereof is laid or closed-in. **HEAR NOTICE IS REQUIRED.**

A certificate of occupancy must be procured by owner before this building or part thereof is occupied.

OTHER REQUIRED APPROVALS

Fire Dept. W **PERMIT ISSUED**
Health Dept. _____
Appeal Board _____
Other _____
MAY 07 2003
Department Name

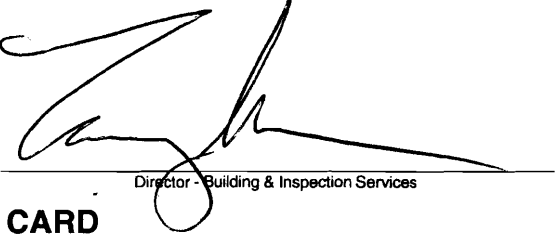
Director - Building & Inspection Services

CITY OF PORTLAND PENALTY FOR REMOVING THIS CARD

City of Portland, Maine - Building or Use Permit Application

389 Congress Street, 04101 Tel: (207) 874-8703, Fax: (207) 874-8716

Permit No: 03-0389	Issue Date: MAY 07 2003	CBL: 045 A010001
-----------------------	-----------------------------------	---------------------

Location of Construction: 130 Park St	Owner Name: Shalom House Inc	Owner Address: Po Box 560 CITY OF PORTLAND	Phone: 874-1080
Business Name:	Contractor Name: Larry Hall	Contractor Address: P.O. Box 9715-168 Portland	Phone: 2077717979
Lessee/Buyer's Name	Phone:	Permit Type: Alterations - Multi Family	Zone: B3

Past Use: Group Home/Shalom House	Proposed Use: Group Home/Shalom House	Permit Fee: \$51.00	Cost of Work: \$3,500.00	CEO District: 2
Proposed Project Description: Replace beam underneath porch on side of building		FIRE DEPT: <input checked="" type="checkbox"/> Approved <input type="checkbox"/> Denied	INSPECTION: Use Group: R Type: SB BOCA 99	
		Signature: <i>[Signature]</i>	Signature: <i>[Signature]</i>	
PEDESTRIAN ACTIVITIES DISTRICT (P.A.D.)				
Action: <input type="checkbox"/> Approved <input type="checkbox"/> Approved w/Conditions <input type="checkbox"/> Denied				
Signature: _____ Date: _____				

Permit Taken By: gad	Date Applied For: 04/22/2003	Zoning Approval		
-------------------------	---------------------------------	------------------------	--	--

1. This permit application does not preclude the Applicant(s) from meeting applicable State and Federal Rules. 2. Building permits do not include plumbing, septic or electrical work. 3. Building permits are void if work is not started within six (6) months of the date of issuance. False information may invalidate a building permit and stop all work..	Special Zone or Reviews <input type="checkbox"/> Shoreland <input type="checkbox"/> Wetland <input type="checkbox"/> Flood Zone <input type="checkbox"/> Subdivision <input type="checkbox"/> Site Plan Maj <input type="checkbox"/> Minor <input type="checkbox"/> MM <input type="checkbox"/> <i>OK 5/2/03</i> Date:	Zoning Appeal <input type="checkbox"/> Variance <input type="checkbox"/> Miscellaneous <input type="checkbox"/> Conditional Use <input type="checkbox"/> Interpretation <input type="checkbox"/> Approved <input type="checkbox"/> Denied Date:	Historic Preservation <input type="checkbox"/> Not in District or Landmark <input type="checkbox"/> Does Not Require Review <input type="checkbox"/> Requires Review <input type="checkbox"/> Approved <input checked="" type="checkbox"/> Approved w/Conditions <input type="checkbox"/> Denied <i>to P.A. 5/2/03</i> <i>DM 8/5/03</i> Date:
--	---	---	---

CERTIFICATION

I hereby certify that I am the owner of record of the named property, or that the proposed work is authorized by the owner of record and that I have been authorized by the owner to make this application as his authorized agent and I agree to conform to all applicable laws of this jurisdiction. In addition, if a permit for work described in the application is issued, I certify that the code official's authorized representative shall have the authority to enter all areas covered by such permit at any reasonable hour to enforce the provision of the code(s) applicable to such permit.

SIGNATURE OF APPLICANT _____ ADDRESS _____ DATE _____ PHONE _____

RESPONSIBLE PERSON IN CHARGE OF WORK, TITLE _____ DATE _____ PHONE _____

130 Park Street
Portland

Plot Plan

B-3 Zone
No Setback Req.

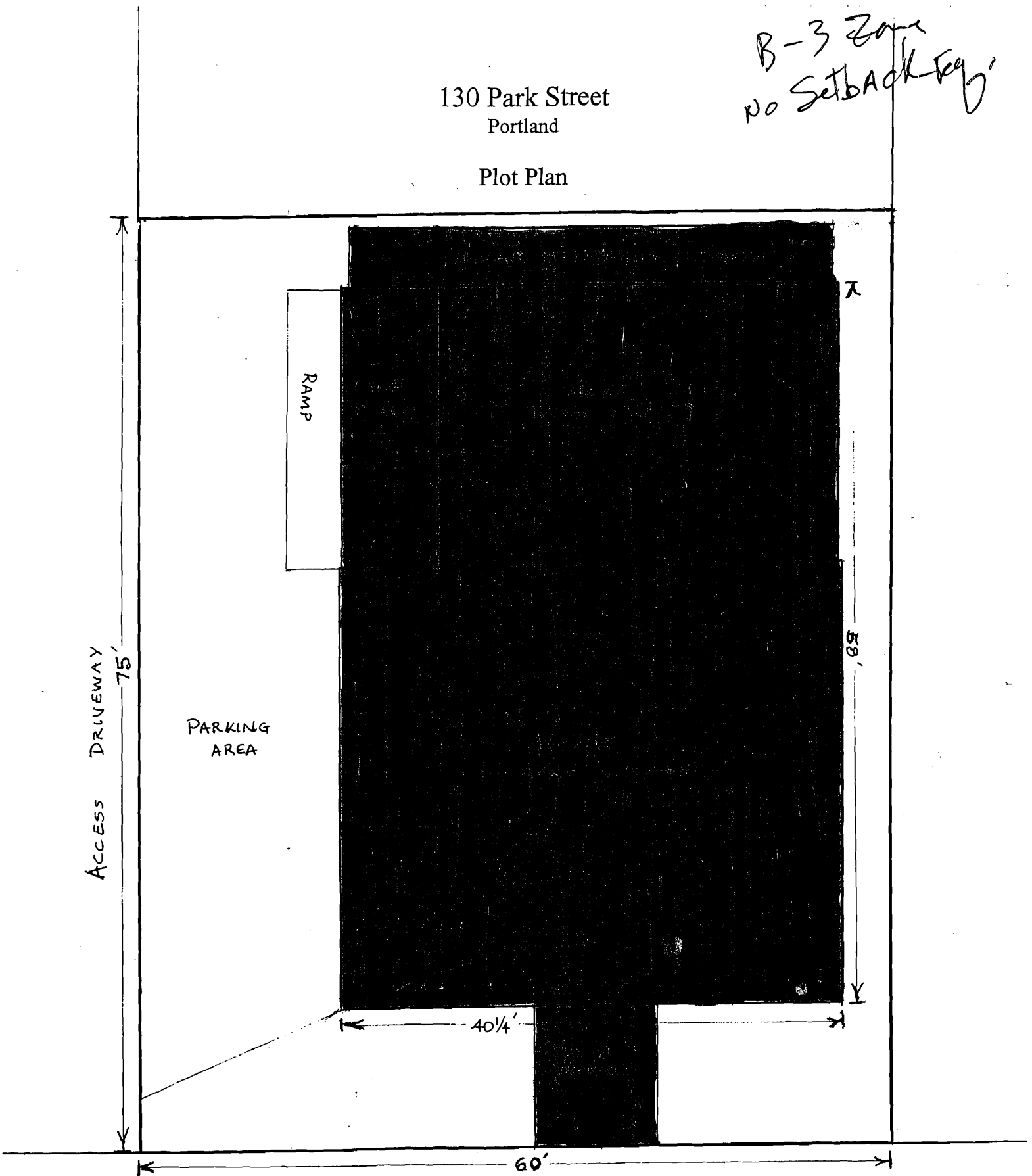

Prepared by: Norman E. Maze, Jr./ Shalom House, Property Manager 6/24/02

BACK STAIR Revised

PLAN B

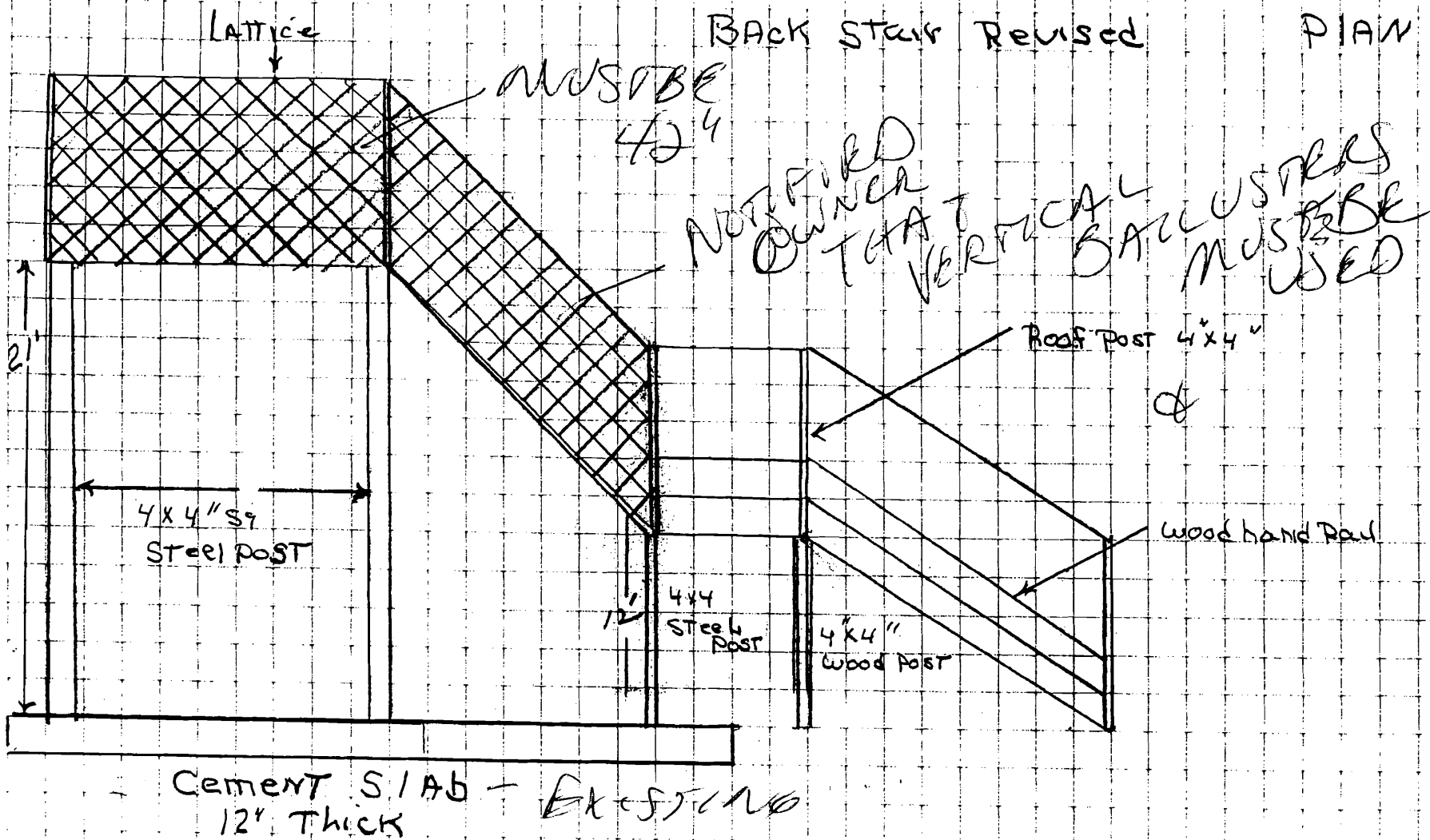

Cement Slab - Existing
12" Thick

PLAN A

BACK STAIR
Existing

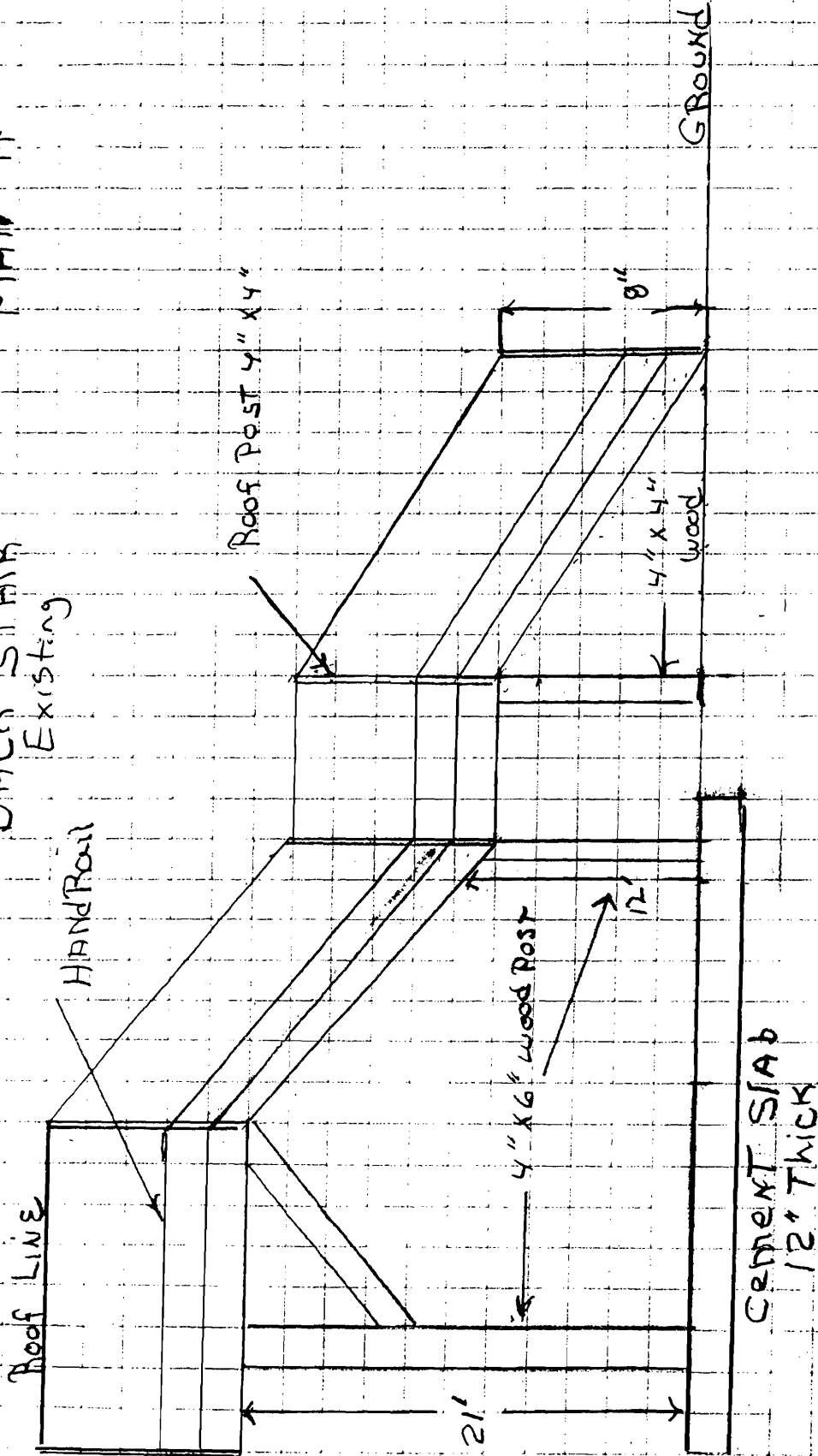

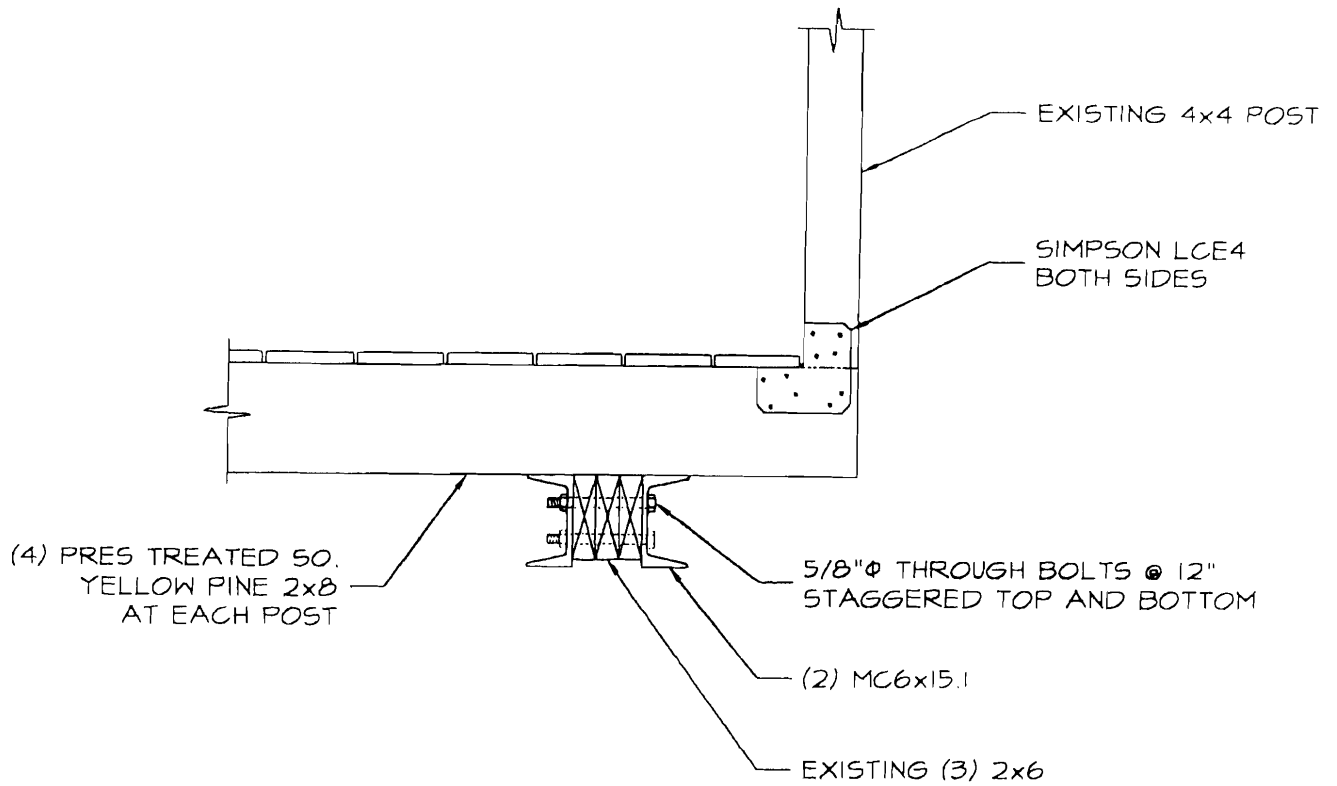

SECTION THROUGH FIRST FLOOR PORCH FRAMING

1' = 1'-0"

GALVANIZE OR COAT STEEL CHANNELS WITH HIGH QUALITY EPOXY PAINT AFTER DRILLING BOLT HOLES.

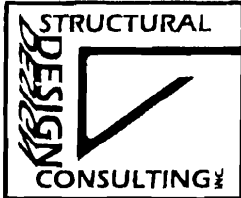
date	revision number	130 PARK STREET PORTLAND, MAINE		SSK1
01/21/02				

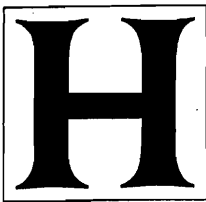

L. W. HALL

LARRY W. HALL
PRESIDENT

P.O. Box 9715-168
PORTLAND, ME
04104-5015

(207)771-7979
FAX (207)771-7979

PROVIDING
MAINTENANCE
SERVICE TO:

HOMES

CONDOMINIUMS

RENTAL PROPERTIES

ELECTRICAL

MECHANICAL

PLUMBING

LIGHT

CONSTRUCTION

PAINTING

ON CALL

24 HOURS/DAY

FULLY INSURED

May 14, 2002

*Shalom House Inc.
P. O. Box 560
Portland, ME 04112*

*Property: 130 Park Street
Portland, ME*

L. W. Hall would like to submit the following proposal to make changes on the outside staircases on the back side of the building.

(1) Plan A: Show a post that is of wood 2 feet in length and that is beginning to twist and break apart.

Plan B: Show that this post would be replaced with two 4x4x21 foot steel post. These would be anchored at the top and the bottom. These would also be primed and painted.

(2) Plan A: Show that the first two landings have just handrails. There have been complaints that people are able to jump onto the roof top of the abutting property.

Plan B: Without making any structural changes, place lattice work on the outside of the first two landings so this cannot be done. There are no plans to make any other changes.

Respectfully Submitted,

Larry Hall

We do the little things in a big way.

City of Portland, Maine - Building or Use Permit

389 Congress Street, 04101 Tel: (207) 874-8703, Fax: (207) 874-8716

Permit No: 04-1425	Date Applied For: 09/23/2004	CBL: 045 A010001
------------------------------	--	----------------------------

Location of Construction: 130 Park St	Owner Name: Shalom House Inc	Owner Address: Po Box 560	Phone:
Business Name:	Contractor Name: Larry Hall	Contractor Address: P.O. Box 9715-168 Portland	Phone: (207) 771-7979
Lessee/Buyer's Name	Phone:	Permit Type: Alterations - Commercial	

Proposed Use: commercial replace stair supports and reinforcement of porch beam	Proposed Project Description: replace stair supports and reinforcement of porch beam
---	--

Dept: Zoning	Status: Approved	Reviewer: Marge Schmuckal	Approval Date: 10/06/2004	Ok to Issue: <input checked="" type="checkbox"/>
Note:				
Dept: Building	Status: Pending	Reviewer: Mike Nugent	Approval Date:	Ok to Issue: <input type="checkbox"/>
Note:				
Dept: Fire	Status: Approved	Reviewer: Lt. MacDougal	Approval Date: 10/07/2004	Ok to Issue: <input checked="" type="checkbox"/>
Note:				

Comments: 10/12/2004-mjn: Scope of the project is unclear left a message with applicant
