

Prepared For:
**DEVELOPERS
COLLABORATIVE**
Address
City, State

Consultant:
**ARCHETYPE
architects**
48 Union Wharf Portland, Maine 04101
(207) 772-0022 ARCHETYPE@ARCHETYPEA.COM

Architect:
**ROSA TRUE
APARTMENTS**
140 PARK STREET, PORTLAND, ME

Project:
**ROSA TRUE
APARTMENTS**

Revisions:
Scale: As indicated
Date: 20 MAY, 2015
**WALL AND
CEILING/FLOOR TYPES**

A4.00

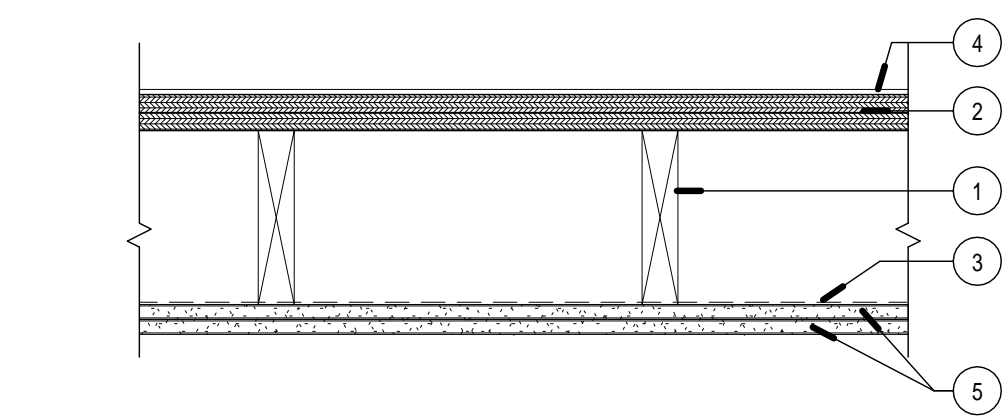

C2
LABEL 1 HR
1 HOUR RATED CEILING/FLOOR ASSEMBLY
GA FILE NO. FC 5406
FIRE TEST: FM FC 172, 2.25.72; ITS, 8.6.98

- EXIST FLOOR JOISTS - EXIST 2x12 WOOD FLOOR JOISTS AT 16" OC.
- EXIST SUBFLOOR - 2 LAYERS EXIST 3/4" WOOD PLANK SUBFLOOR
- EXIST CEILING - REMOVE EXIST PLASTER ON LATH CEILING
- FINISH FLOOR - NOT SHOWN, SEE FINISH SCHEDULE.
- GYPSUM SHEATHING - 2 LAYERS 5/8" GYPSUM WALLBOARD BASE LAYER APPLIED AT RIGHT ANGLES TO JOISTS WITH 1 1/4" TYPE W OR S DRYWALL SCREWS AT 24" OC. FACE LAYER APPLIED AT RIGHT ANGLES TO JOISTS WITH 1 7/8" TYPE W OR S DRYWALL SCREWS AT 12" OC AT JOISTS AND INTERMEDIATE JOISTS AND 1 1/2" TYPE G DRYWALL SCREWS 12" OC PLACED 2" BACK ON EITHER SIDE OF END JOISTS. JOISTS OFFSET 24" FROM BASE LAYER JOINTS.

7 | C2 - CEILING OVER HALLWAY & STAIRS
1 1/2" = 1'-0"

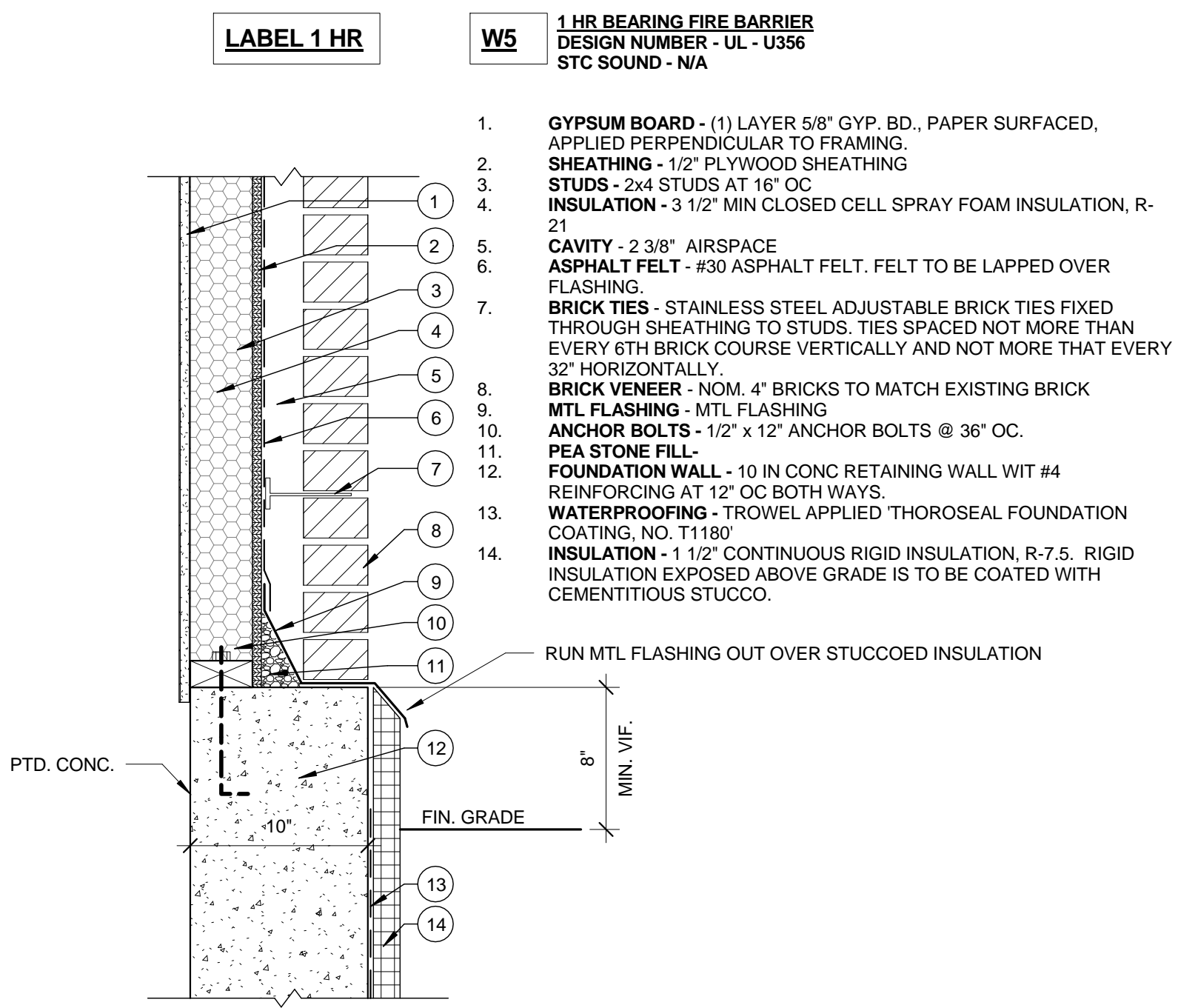

5 | WALL TYPE 5 - EXT BRICK VENEER WALL
1 1/2" = 1'-0"

- W5** 1 HR BEARING FIRE BARRIER
DESIGN NUMBER - UL - U356
STC SOUND - N/A
- GYPSUM BOARD - (1) LAYER 5/8" GYP. BD., PAPER SURFACED, APPLIED PERPENDICULAR TO FRAMING.
 - SHEATHING - 1/2" PLYWOOD SHEATHING
 - STUDS - 2x4 STUDS AT 16" OC
 - INSULATION - 3 1/2" MIN CLOSED CELL SPRAY FOAM INSULATION, R-21
 - CAVITY - 2 3/8" AIRSPACE
 - ASPHALT FELT - #30 ASPHALT FELT, FELT TO BE LAPPED OVER FLASHING.
 - BRICK TIES - STAINLESS STEEL ADJUSTABLE BRICK TIES FIXED THROUGH SHEATHING TO STUDS. TIES SPACED NOT MORE THAN EVERY 6TH BRICK COURSE VERTICALLY AND NOT MORE THAN EVERY 32" HORIZONTALLY.
 - BRICK VENEER - NOM. 4" BRICKS TO MATCH EXISTING BRICK
 - MTL FLASHING - MTL FLASHING
 - ANCHOR BOLTS - 1/2" x 12" ANCHOR BOLTS @ 36" OC.
 - PEA STONE FILL - FOUNDATION WALL - 10 IN CONC RETAINING WALL WIT #4 REINFORCING AT 12" OC BOTH WAYS.
 - FOUNDATION WALL - 10 IN CONC RETAINING WALL WIT #4 REINFORCING AT 12" OC BOTH WAYS.
 - WATERPROOFING - TROWEL APPLIED THOROSEAL FOUNDATION COATING, NO. T1180
 - INSULATION - 1 1/2" CONTINUOUS RIGID INSULATION, R-7.5. RIGID INSULATION EXPOSED ABOVE GRADE IS TO BE COATED WITH CEMENTITIOUS STUCCO.

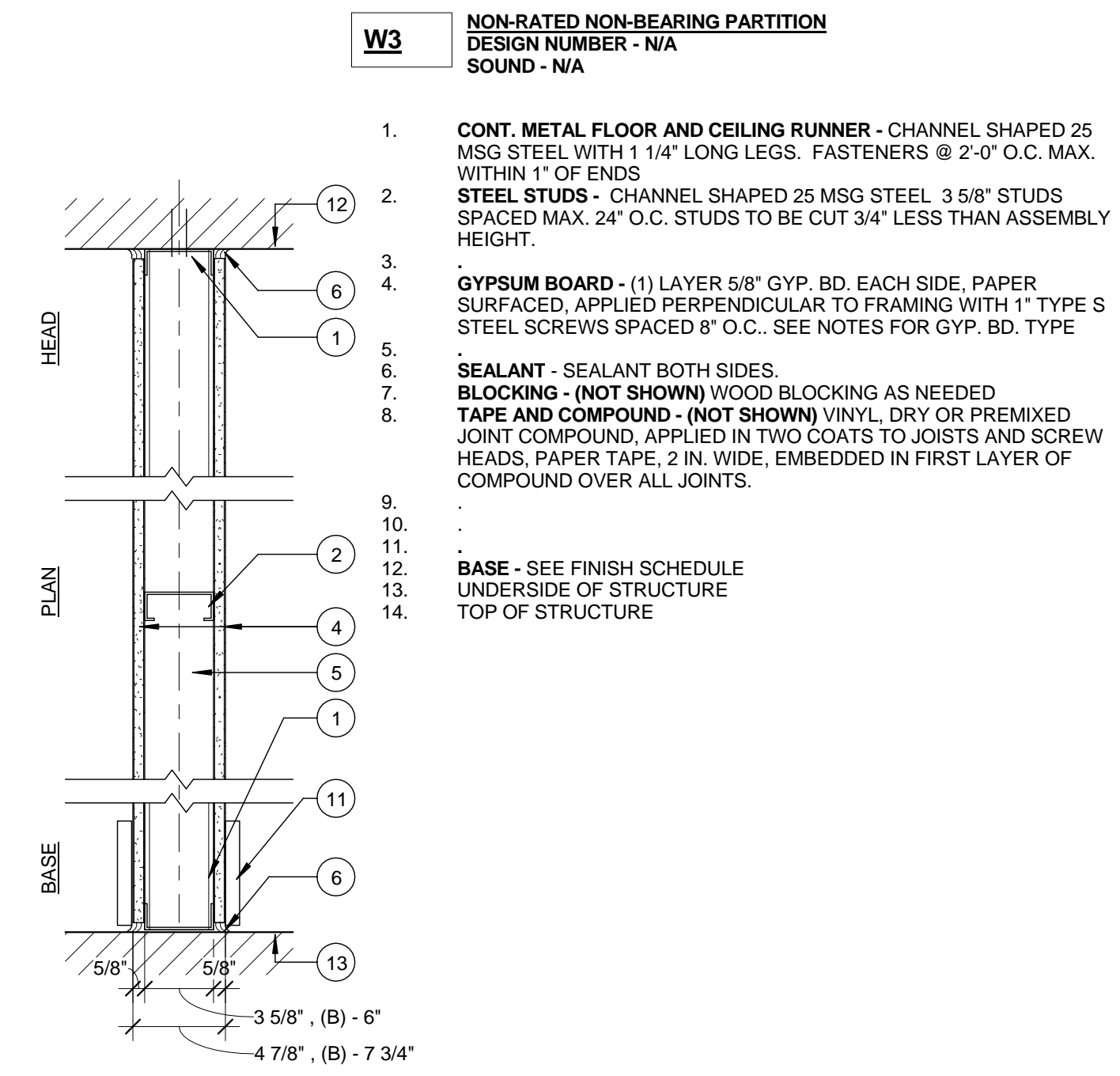

3 | WALL TYPE 3 - NON RATED UNIT INTERIOR PARTITION
1 1/2" = 1'-0"

- W3** NON-RATED NON-BEARING PARTITION
DESIGN NUMBER - N/A
SOUND - N/A
- CONT. METAL FLOOR AND CEILING RUNNER - CHANNEL SHAPED 25 MSG STEEL WITH 1 1/4" LONG LEGS. FASTENERS @ 2'-0" O.C. MAX. WITHIN 1" OF ENDS
 - STEEL STUDS - CHANNEL SHAPED 25 MSG STEEL 3 5/8" STUDS SPACED MAX. 24" O.C. STUDS TO BE CUT 3/4" LESS THAN ASSEMBLY HEIGHT.
 - GYPSUM BOARD - (1) LAYER 5/8" GYP. BD. EACH SIDE, PAPER SURFACED, APPLIED PERPENDICULAR TO FRAMING WITH 1" TYPE S STEEL SCREWS SPACED 8" O.C. SEE NOTES FOR GYP. BD. TYPE
 - SEALANT - SEALANT BOTH SIDES.
 - BLOCKING - (NOT SHOWN) WOOD BLOCKING AS NEEDED
 - TAPE AND COMPOUND - (NOT SHOWN) VINYL DRY OR PREMIXED JOINT COMPOUND, APPLIED IN TWO COATS TO JOISTS AND SCREW HEADS, PAPER TAPE, 2 IN. WIDE, EMBEDDED IN FIRST LAYER OF COMPOUND OVER ALL JOINTS.
 - BASE - SEE FINISH SCHEDULE UNDERSIDE OF STRUCTURE TOP OF STRUCTURE

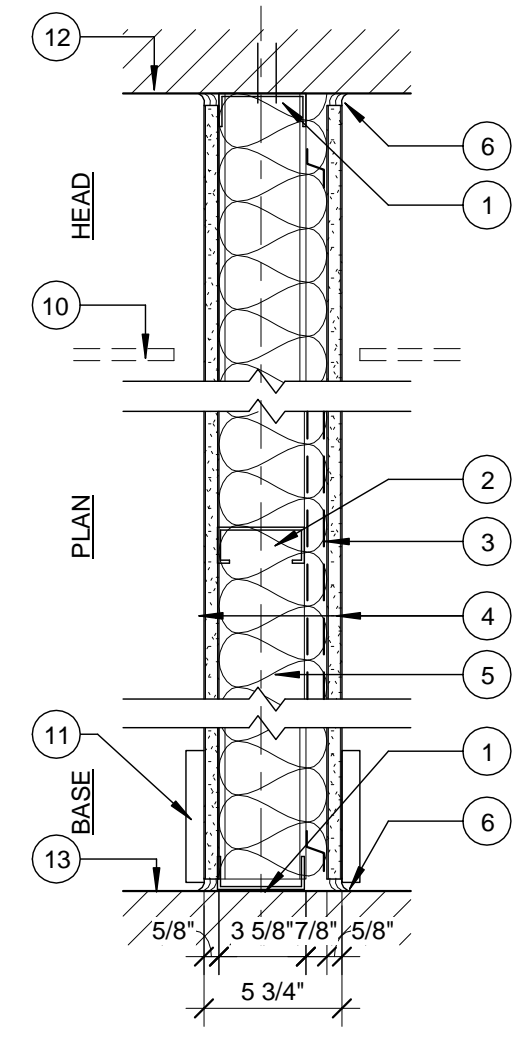

2 | WALL TYPE 2 - MTL STD - CORRIDOR & STAIR ENCLOSURE
1 1/2" = 1'-0"

- W2** 1 HR NON-BEARING FIRE BARRIER
DESIGN NUMBER - UL U451
55-59 STC SOUND - RAL-TL-10-270
- CONT. METAL FLOOR AND CEILING RUNNER - FASTENERS @ 2'-0" O.C. MAX. WITHIN 1" OF ENDS
 - STEEL STUDS - 3 5/8" STEEL STUDS 24" O.C.
 - SOUND ISOLATION FURRING - RESILIENT SOUND ISOLATION CLIP (ONE SIDE), ORIENTED PERPENDICULAR TO STUDS, 24" O.C. ATTACH WITH #8 WAFER HEAD SCREWS.
 - TYPE X GYPSUM BOARD - (1) LAYER PROPRIETARY 5/8" TYPE X GYP. BD. EACH SIDE, APPLIED PERPENDICULAR TO STUDS WITH 1" TYPE S DRYWALL SCREWS 8" O.C. AT VERT. JNTS AND INTERMEDIATE STUDS AND 12" O.C. AT TOP AND BOTTOM RUNNER. SEE NOTES FOR GYP. BD. TYPE (STAGGER GYP. BD. JNTS 24" ON NON-FURRED SIDE.)
 - SOUND BATT - GLASS FIBER INSULATION 6 1/4" THICK, COMPRESSED AND FRICTION FIT IN STUD SPACE.
 - SEALANT - UL AND STC LISTED SEALANT, FULL PERIMETER BOTH SIDES.
 - BLOCKING - (NOT SHOWN) WOOD BLOCKING AS NEEDED
 - TAPE AND COMPOUND - (NOT SHOWN) VINYL DRY OR PREMIXED JOINT COMPOUND, APPLIED IN TWO COATS TO JOISTS AND SCREW HEADS, PAPER TAPE, 2 IN. WIDE, EMBEDDED IN FIRST LAYER OF COMPOUND OVER ALL JOINTS.
 - CEILING - SEE ID
 - SCHEDULED BASE - SEE ID
 - UNDERSIDE OF FLOOR SHEATHING
 - TOP OF STRUCTURE
- WALL AND GYPBD TO BE RUN CONTINUOUS THROUGH FLOOR FRAMING TO UNDERSIDE OF FLOOR SHEATHING. CAULK GYPBD TO SHEATHING AND FLOOR FRAMING WITH 1 HR RATED CAULK.

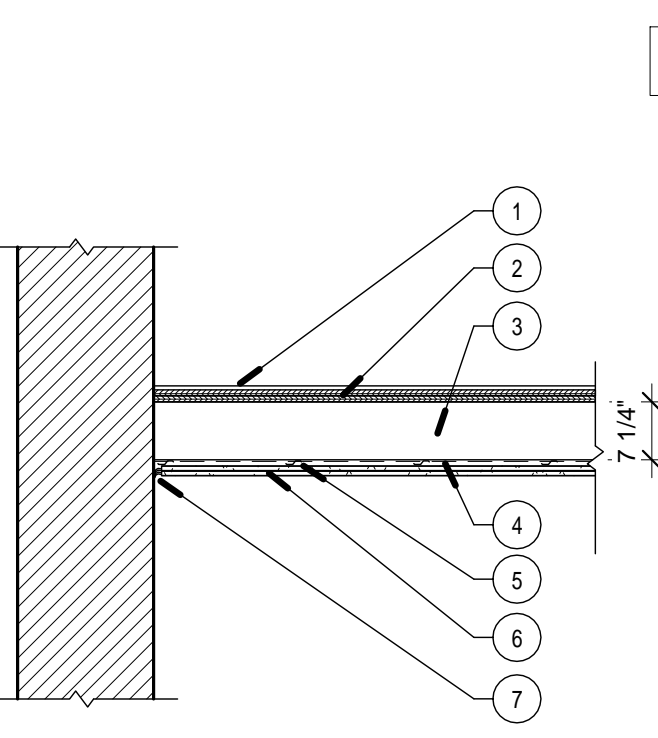

C1 CEILING SYSTEM
1 HR RATING
GA FILE NO. FC 5111
FIRE TEST: NRCC A-4440.1 (REVISED), 6-24-97
STC SOUND - 50-54

LABEL 1 HR

- FINISH FLOOR - SEE FINISH SCHED.
- EXIST SUBFLOOR - 2 LAYERS EXIST 3/4" WOOD PLANK SUBFLOOR
- EXIST FLOOR JOISTS - EXIST 2x12 WOOD FLOOR JOISTS AT 16" OC.
- REMOVE EXIST CEILING - REMOVE EXIST PLASTER ON LATH CEILING
- RESILIENT CHANNELS - FORMED FROM MIN 0.020 IN. THICK GALV STEEL, 1/2 IN. DEEP BY 2-3/8 IN. WIDE AT THE BASE AND 1-3/8 IN. WIDE AT THE FACE AS SHOWN, SPACED 12 IN. OC PERPENDICULAR TO TRUSSES. CHANNELS SECURED TO EACH TRUSS WITH 1-1/4 IN. LONG TYPE S BUGLE HEAD STEEL SCREWS. CHANNELS OVERLAPPED 4 IN. AT SPLICES. TWO CHANNELS, SPACED 6 IN. OC, ORIENTED OPPOSITE EACH OTHER AT GYPSUM PANEL END JOINTS AS SHOWN IN THE ILLUSTRATION. ADDITIONAL CHANNELS SHALL EXTEND MIN 6 IN. BEYOND EACH SIDE EDGE OF PANEL.
- CEILING - (2) LAYERS 5/8" TYPE X GYPSUM WALL BOARD FASTENED TO RESILIENT CHANNEL WITH 1-1/4" TYPE S DRYWALL SCREWS AT 12" OC.
- SEALANT - UL AND STC LISTED SEALANT, FULL PERIMETER.
- TAPE AND COMPOUND - (NOT SHOWN) VINYL DRY OR PREMIXED JOINT COMPOUND, APPLIED IN TWO COATS TO JOISTS AND SCREW HEADS, PAPER TAPE, 2 IN. WIDE, EMBEDDED IN FIRST LAYER OF COMPOUND OVER ALL JOINTS.

NOTE:
THE 2 LAYERS OF GYPBOARD MUST RUN CONTINUOUS ACROSS ENTIRE CEILING.
SOFFITS FOR EXHAUST VENTS AND ABOVE CABINETS MUST BE SEPARATED FROM THE FLOOR VOID BY THE 2 CONTINUOUS GYPBOARD LAYERS.

6 | C1 CEILING OVER NEW BASEMENT UNITS
1 1/2" = 1'-0"

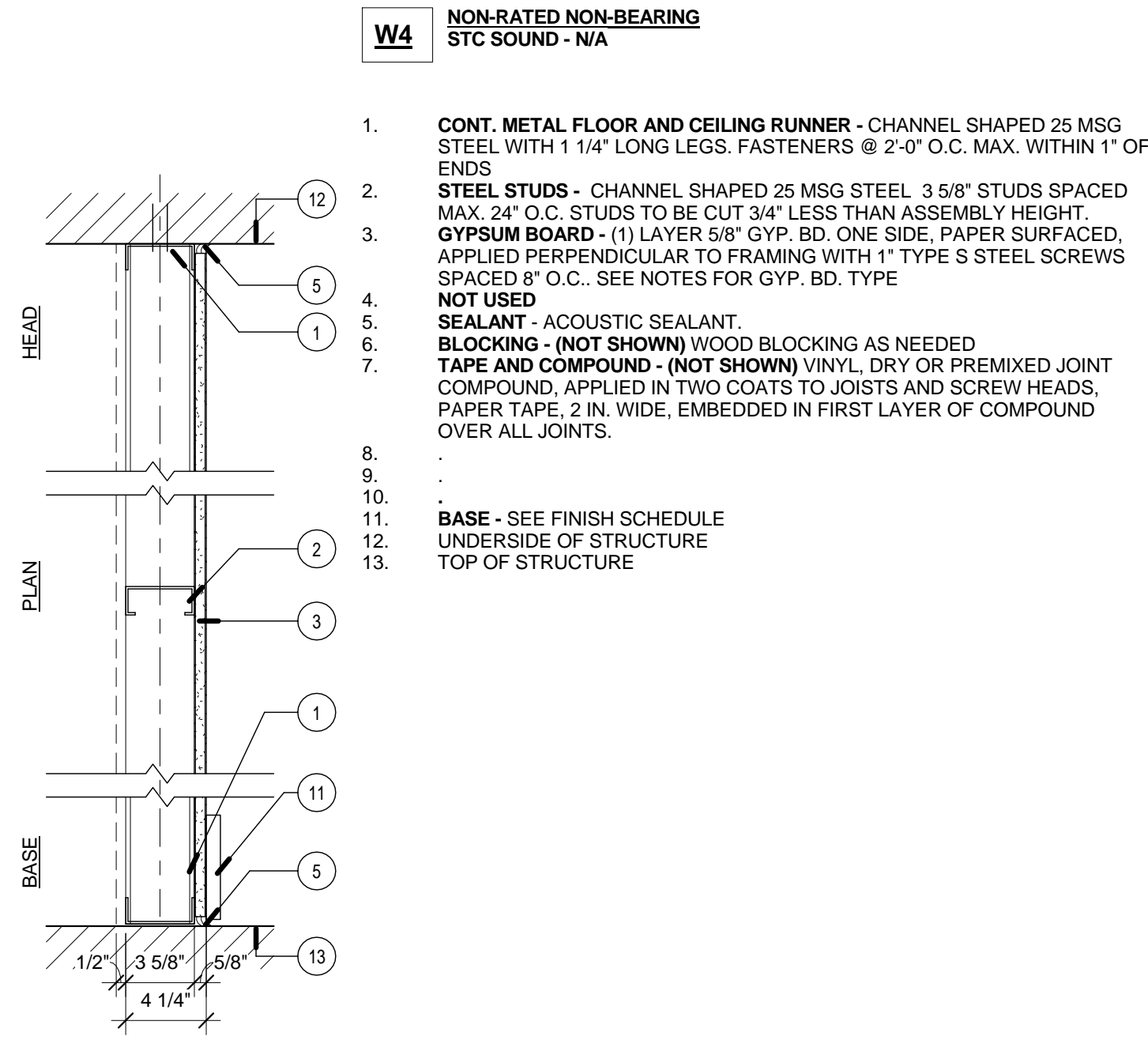

4 | WALL TYPE 4 - NON RATED SINGLE SIDED UNIT INTERIOR PARTITION
1 1/2" = 1'-0"

- W4** NON-RATED NON-BEARING
STC SOUND - N/A
- CONT. METAL FLOOR AND CEILING RUNNER - CHANNEL SHAPED 25 MSG STEEL WITH 1 1/4" LONG LEGS. FASTENERS @ 2'-0" O.C. MAX. WITHIN 1" OF ENDS
 - STEEL STUDS - CHANNEL SHAPED 25 MSG STEEL 3 5/8" STUDS SPACED MAX. 24" O.C. STUDS TO BE CUT 3/4" LESS THAN ASSEMBLY HEIGHT.
 - GYPSUM BOARD - (1) LAYER 5/8" GYP. BD. ONE SIDE, PAPER SURFACED, APPLIED PERPENDICULAR TO FRAMING WITH 1" TYPE S STEEL SCREWS SPACED 8" O.C. SEE NOTES FOR GYP. BD. TYPE
 - NOT USED
 - SEALANT - ACOUSTIC SEALANT
 - BLOCKING - (NOT SHOWN) WOOD BLOCKING AS NEEDED
 - TAPE AND COMPOUND - (NOT SHOWN) VINYL DRY OR PREMIXED JOINT COMPOUND, APPLIED IN TWO COATS TO JOISTS AND SCREW HEADS, PAPER TAPE, 2 IN. WIDE, EMBEDDED IN FIRST LAYER OF COMPOUND OVER ALL JOINTS.
 - BASE - SEE FINISH SCHEDULE UNDERSIDE OF STRUCTURE TOP OF STRUCTURE

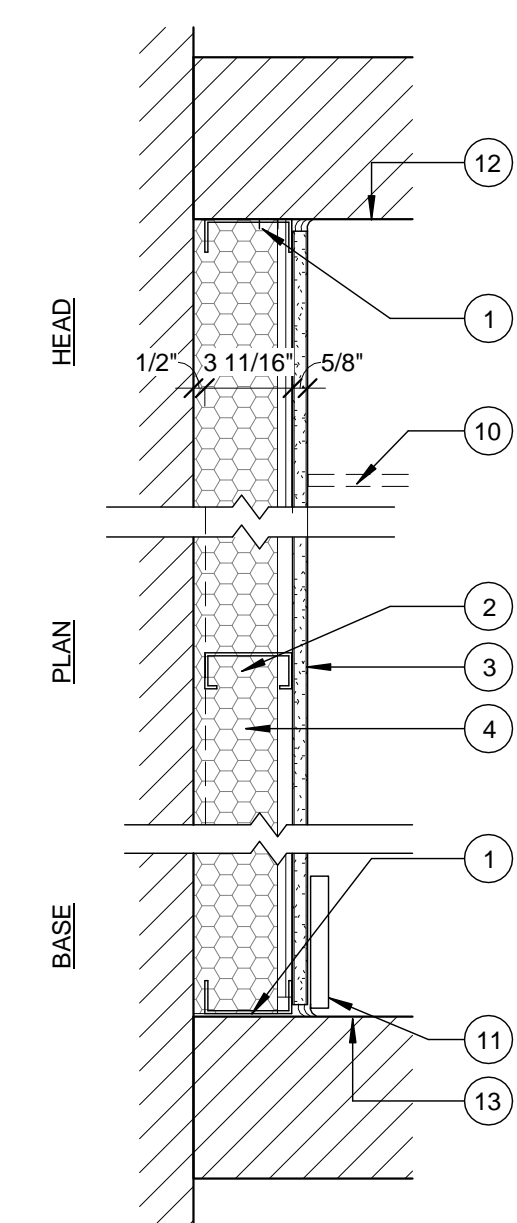

1 | WALL TYPE 1
1 1/2" = 1'-0"

- W1** NON-BEARING EXTERIOR WALL FURRING
STC SOUND - N/A
R-21
- CONT. METAL FLOOR AND CEILING RUNNER - CHANNEL SHAPED 25 MSG STEEL WITH 1 1/4" LONG LEGS. FASTENERS @ 2'-0" O.C. MAX. WITHIN 1" OF ENDS
 - STEEL STUDS - CHANNEL SHAPED 25 MSG STEEL 2 1/2" STUDS SPACED MAX. 24" O.C. STUDS TO BE CUT 3/4" LESS THAN ASSEMBLY HEIGHT.
 - GYPSUM BOARD - (1) LAYER 5/8" GYP. BD., PAPER SURFACED MOISTURE RESISTANT, APPLIED PERPENDICULAR TO FRAMING WITH 1" TYPE S STEEL SCREWS SPACED 8" O.C.
 - SPRAY FOAM INSULATION - CLOSED CELL POLYURETHANE SPRAY INSULATION UL CLASS AS TO SURFACE BURNING CHARACTERISTICS AND OR FIRE RESISTANCE REQUIRED TO COMPLETELY FILL CAVITY
 - BLOCKING - (NOT SHOWN) BLOCKING AS NEEDED
 - TAPE AND COMPOUND - (NOT SHOWN) VINYL DRY OR PREMIXED JOINT COMPOUND, APPLIED IN TWO COATS TO JOISTS AND SCREW HEADS, PAPER TAPE, 2 IN. WIDE, EMBEDDED IN FIRST LAYER OF COMPOUND OVER ALL JOINTS.
 - CEILING - SEE ID
 - SCHEDULED BASE - SEE ID
 - UNDERSIDE OF STRUCTURE
 - TOP OF STRUCTURE