



Norris Inc.

PO Box 2551
2257 West Broadway
South Portland, ME 04106

1.800.370.3473
fax 207.879.0540



Permitting and Inspections Department
Approved with Conditions
www.norrisinc.com

07/06/2018

Please fax this information to the Administrative Sales Assistant at the So. Portland Office at (207)-879-0540.

Building Owner Information Form

Job Name:	Project #:
------------------	-------------------

Electrical Contractor:

NFPA requires this information for proper documentation

****The contractor MUST provide all of the information with an asterisk below before ANY equipment can be released.***

If building owner contact is unknown provide contact name/tel. of GC and check box

Electrical Contractor Contact Name:	
Estimated Date Equip. Needed:	*Estimated Finals Date:

*Building Owner:

*Job Site Address:

*City:	State:	Zip:
---------------	---------------	-------------

*Contact Name: _____ Check here if GC

*Phone #:	Fax #:
------------------	---------------



Norris Inc.

PO Box 2551
2257 West Broadway
South Portland, ME 04106

1.800.370.3473
fax 207.879.0540



Permitting and Inspections Department
Approved with Conditions
www.norrisinc.com
07/06/2018

Thank you for your cooperation.

Please advise the building owners that if this system is equipped with a digital communicator, then they MUST also make monitoring arrangements prior to a certificate of occupancy. Norris Inc. will attempt to contact the building owners





Norris Inc.

PO Box 2551
2257 West Broadway
South Portland, ME 04106

1.800.370.3473
fax 207.879.0540



Permitting and Inspections Department
Approved with Conditions
www.norrisinc.com
07/06/2018

STOP!

**THIS COPY IS FOR YOUR ELECTRICIAN
ON THE JOB-SITE**

PLEASE BE SURE THIS COPY IS FORWARDED

- 1) **A riser diagram is enclosed. DO NOT USE THE ENGINEER'S RISER SHOWN ON THE PLANS. If there is any information that you question, call us immediately.**
 - 2) **YOU MUST CALL AT LEAST FIVE DAYS IN ADVANCE TO SCHEDULE FINAL CONNECTION ASSISTANCE.**
 - 3) **All of your wires must be labeled and clear of any grounds, shorts or opens and must maintain polarity throughout. Meter out all circuits before calling for final connection assistance. If applicable verify End of Line resistors are in place.**
 - 4) **If using shielded cable, the drain wires must be connected and fully insulated (wrapped with tape) so that neither the shield or the drain wire touches the backbox.**
 - 5) **Unless special arrangements are made, we will make one final job-site visit. If a special visit is required for an elevator inspection or partial occupancy, then additional charges may apply if special arrangements were not made ahead. Call your customer service representative.**
 - 6) **If you have any defective or left-over parts DO NOT WRITE ON THEM OR THE BOXES. Save the original box, all mounting hardware and instructions. Returns that do not conform to this practice will not be accepted for credit.**
 - 7) **If the system is being monitored through a digital communicator, then please turn to page 2.**
-



Norris Inc.

PO Box 2551
2257 West Broadway
South Portland, ME 04106

1.800.370.3473
fax 207.879.0540

IMPORTANT INFORMATION FOR THE BUILDING OWNERS SPECIAL NOTE REGARDING ALARM MONITORING SERVICES

Included within your alarm system package is a digital communicator, which sends a coded message to a private 24-hour central station if your alarm system is activated. This is a code requirement for most fire alarm systems. As a service to our customer, we offer central station monitoring services from our local UL Listed central station at extremely competitive rates.

If the central station monitoring contract is purchased through Norris Inc. prior to our scheduled start-up; we will connect, program, and test the communicator at no additional charge.

Should the building owners decide to obtain monitoring services from another company, then the cost for programming and testing the communicator will be the sole responsibility of the firm they have contracted with. Furthermore, if programming changes are made to the system by persons other than Norris Inc. technicians, then the company performing the changes shall be solely liable for any personal injury or loss of life or damage to or loss of property arising out of the use of or inability to use the system and it shall result in a waiver of any system warranties.

We appreciate that you understand the delicate nature of this life safety and/or security system and realize that serious problems may arise when modifications to the system are made including very simple programming changes.

**Call Norris Inc. at 1-800-370-FIRE (3473) to make
arrangements for central station monitoring services.**



Permitting and Inspections Department
Approved with Conditions

07/06/2018

www.norrisinc.com



Norris Inc.

PO Box 2551
2257 West Broadway
South Portland, ME 04106

1.800.370.3473
fax 207.879.0540

SUBMITTAL PACKAGE

Project: Poke Pop - 658 Congress Street

System: Fire Alarm

Submitted By: **Norris Inc.**
2257 West Broadway
South Portland, Maine 04106
Telephone: (800) 370-3473

Date: 6/20/2018



Company Profile

"We are extremely proud to represent the highest quality manufacturers integrating life safety, alarm and communication systems throughout northern New England."

-- Bradford Norris, President --

Mission Statement

Provide quality engineered systems, exceptional service.

Goal

Learn...Continually Improve...Exceed Expectations

Founded in 1979 Norris Inc. has grown to become Northern New England's leading integrated system contracting and supply company. Norris Inc. is an innovated proactive organization with extensive experience in integration interdisciplinary building management systems. Our local and national affiliations assure that your project will be done properly regardless of size representing leading manufacturers our comprehensive products provide outstanding quality reliability and performance... surpassing customer application requirements and exceeding the stringent requirements of Underwriters Laboratories, National Fire Protection Association and other codes. We maintain an exceptional level of quality and provide the highest levels of customer service. Our knowledgeable technical support will insure the great service you deserve. Whether your needs involve industrial, commercial, institutional, or educational applications, you can trust that Norris Inc. has the complete resources it takes to provide the right solution right away.



Norris Inc.

PO Box 2551
2257 West Broadway
South Portland, ME 04106

1.800.370.3473
fax 207.879.0540

LIMITED WARRANTY

Norris, Inc. warrants that the products of its manufacturers shall be free from defects in materials or workmanship as warranted by the manufacturer which is typically for a one (1) year period from the completed installation date, but not always. The completed installation date will be the date when the end-user was able to begin using or started using the product(s) or the system, whether partially or in its entirety. For projects that have a specification or bid instructions to follow which contains specific warranty requirements, Norris Inc. will always honor the warranty terms exactly as specified in the project's specifications or bid documents, which may be more or less in coverage and duration than the manufacturer's warranty. In performing hundreds of projects per year with thousands of different products it is impossible for Norris, Inc. to track the terms and details of specified or individual product warranties. Therefore Norris, Inc. will request that the owner's representative provide these special warranty details when the warranty work is requested; otherwise a standard one year warranty on the equipment will be honored. The manufacturer's warranty is for equipment only and does not include any labor and/or shipping costs. All warranties provided by Norris, Inc. are limited with the same limitations included with the manufacturer's warranty which is included in the manuals of the products being provided.

The warranty will apply only if such goods have been properly installed, are subject to normal proper use and have not been modified in any manner whatsoever. Upon return of the defective product, Norris, Inc. will, at its sole discretion, either repair or replace, at no cost, such goods determined to have a defect in materials or workmanship. In cases of a warranty repair, Norris, Inc. will use its sole discretion to determine if a suitable replacement part can be provided on loan while the repairs are being performed.

All warranty work is performed during regular business hours. If emergency warranty work is required, the customer will pay the difference between the emergency service bill and our normal hourly charges.

Norris, Inc.'s limited warranty does not apply to those products that are damaged due to misuse, abuse, negligence, exposure to adverse environmental conditions, acts of God or have been modified in any manner whatsoever.

Norris, Inc.'s Standard terms and conditions are provided with our invoices. Those Terms and Conditions shall be provided upon request.

NORRIS, INC. SHALL NOT UNDER ANY CIRCUMSTANCES BE LIABLE FOR ANY INCIDENTAL OR CONSEQUENTIAL DAMAGES ARISING FROM LOSS OF LIFE &/OR PROPERTY OR OTHER DAMAGE OR LOSSES OWING TO THE FAILURE OF NORRIS INC. PRODUCTS BEYOND THE COST OF REPAIR OR REPLACEMENT OF ANY DEFECTIVE PRODUCTS.

NORRIS, INC. MAKES NO WARRANTY OF FITNESS OR MERCHANTABILITY AND NO OTHER WARRANTY, ORAL OR WRITTEN, EXPRESS OR IMPLIED AS ALLOWED TO THE FULLEST EXTENT OF THE LAW.



07/06/2018



Norris Inc.

PO Box 2551
2257 West Broadway
South Portland, ME 04106

1.800.370.3473
fax 207.879.0540

www.norrisinc.com

OUR CONTINUOUS COMMITMENT TO OUR ENVIRONMENT

At Norris, Inc. we are proudly committed to continuous environmental improvement for a sustainable future and to develop strong partnerships within our community.

Our mission while running our operations is to do everything within our power to improve the environmental quality of our world and to work together to create a clean and safe place to live in and work in for future generations.

We will incorporate and promote green practices within our operations with policies to support it, a system of rewarding those that fully embrace it and then will regularly review our practices for continuous improvement.

We will establish policies, make investments in technologies and set the example in our own operations to include our ongoing commitment to go paperless and making it a requirement to Reuse, Reduce & Recycle, to turn off unneeded lights, to not allow our vehicles to idle, to encourage carpooling and to utilize practical energy efficient transportation.

We will always be 100% compliant with all applicable environmental laws and regulations and will report any violations.

We will remain committed to working locally and whenever possible to sell and use locally manufactured products.

We will insist that every purchase we make will include a review of its environmental impact with a very high priority to selecting the greenest products and services available.

We will remain committed to selling low energy products. This includes promoting wireless technologies, using existing wire infrastructures in our installations, promoting solar powered devices, using our Remote Services in lieu of on-site service calls and performing calculations to minimize power supply and battery needs.

We will educate our employees and customers to illustrate that green practices and purchases are almost always less costly in the long run.

We will support and give priority to organizations that show the strongest commitment to the environment.

We will actively encourage and promote the same responsible green practices that we utilize in the work place to our employees for use in their everyday personal lives.



07/06/2018



Norris Inc.

PO Box 2551
2257 West Broadway
South Portland, ME 04106

1.800.370.3473
fax 207.879.0540

www.norrisinc.com

REMOTE INTERNET CONNECTIONS

As an added service to our customers and in order to facilitate the commissioning of the system(s) being provided within this submittal and then later provide warranty support Norris, Inc. may (at Norris, Inc.'s option) use internet connections to gain access to the system(s) being provided. Many methods can be used, but the most popular is utilizing software named LogMeln. This software or any other method used to connect to the customer's network will allow Norris, Inc.'s technicians the ability to get onto the programming and diagnostic levels of the system(s) being provided via the building owner's or tenant's data network and program, diagnose or make needed changes to the operation of the system(s). This will provide a better working atmosphere to perform programming from a controlled environment without the disruptions of a construction job-site and will allow fast and efficient troubleshooting and/or servicing if problems should occur later. Acceptance of this submittal by those approving it shall constitute an acceptance and approval to perform the work necessary to install and/or enable these network connections if Norris, Inc. chooses to do so. It is the sole responsibility of the submittal approvers to advise the building owners and/or tenants that Norris, Inc. has the ability to gain access to their network. At the specific request of those approving this submittal or the contractor that Norris, Inc. is working for or the building owners or tenants that own the network, Norris, Inc. can remove or disable the ability to connect to the building's network. However, leaving it in place will allow for quicker and more cost effective service when it is needed. Under absolutely no circumstances shall Norris, Inc., its principals, employees or heirs be held responsible for any losses incurred as a result of this network connection or the inability for the network connection to operate as expected.



Permitting and Inspections Department
Approved with Conditions

07/06/2018

This is to certify that

NORRIS, INC.

is an authorized Engineered Systems Distributor for NOTIFIER

During the year of 2018

Richard Bauer
Vice President Sales

ESD Since 1987



Norris Inc
2257 West Broadway
South Portland, ME 04106
1-800-370-3473
Jared Hartley--JWH builders

329875SP
Equipment List

07/06/2018

Poke Pop-- 658 Congress St.

Description

NOTIFIER-5601P, 135 °f (57° c) fixed and rate-of-rise. (plain)
NOTIFIER-CO1224TR, conventional carbon monoxide detector, 12/24 vdc,
NOTIFIER-FCPS-24S8, 8.0 amps, 120 vac remote charger power supply.
IM-1270,12V 7AH Battery
GENTEX-GEC3-24WR, horn strobe, wall, red
GENTEX-GES3-24WR, strobe, wall, red



5600 Series

Mechanical Heat Detectors



Conventional Initiating Devices

GENERAL

System Sensor's 5600 Series mechanical heat detectors offer property protection against fire and for non-life-safety installations, where smoke detectors are inappropriate.

Multiple configurations. The 5600 Series offers a full line of configurations to accommodate a broad range of applications. Both single- and dual-circuit models are offered, each available for low- and high-temperature ratings with either fixed-temperature or combination fixed-temperature/rate-of-rise (ROR) activation. The ROR element of the fixed/ROR models is restorable, to accommodate field-testing the unit.

Installation flexibility. To satisfy a variety of installations, the 5600 Series easily mounts to single-gang and octagonal backboxes. These models also accommodate 4" (101.6 mm) square backboxes when used with a plaster ring. The mounting bracket is reversible to allow for flush- and surface-mount backbox installations.

Visual identification. The 5600 Series provides clear markings on the exterior of the unit to ensure that the proper detector is being used. Alphanumeric characters identify the activation method, as well as the temperature rating, in degrees Fahrenheit and Celsius. Fixed temperature models are identified "FX", while combination fixed/rate-of-rise units are marked "FX/ROR". The 5600 Series also provides a collector as a post-activation indicator. Once the detector has been activated, the collector drops from the unit to allow easy identification of the specific unit in alarm.

FEATURES

- Multiple configurations available:
 - Fixed-temperature (non-resettable) or combination fixed (non-resettable)/rate-of-rise (self-restoring).
 - Low-temperature and high-temperature ratings.
 - Single-circuit and dual-circuit.
- Easy-to-read alphanumeric identification of detector type and temperature rating.
- External collector provides visual indication of activation.
- Reversible mounting bracket for flush- and surface-mount installations.
- Flexible mounting capabilities: single-gang, 3.5" or 4" octagonal, 4" (101.6 mm) square with plaster ring.
- Easy-to-use terminal screws provide a more positive wiring connection.
- Low-profile design to coordinate with room aesthetics.

AGENCY LISTINGS AND APPROVALS

These listings and approvals apply to the modules specified in this document. In some cases, certain modules or applications may not be listed by certain approval agencies, or listing may be in process. Consult factory for latest listing status.

- **UL Listed:** S2101
- **ULC Listed:** S2101 (all with "A" suffix)
- **MEA:** 199-03-E
- **CSFM:** 7270-1209:227, 7270-1653:167
- **FM Approved**



6931ph01.jpg

SPECIFICATIONS

PHYSICAL SPECIFICATIONS

Maximum installation temperature:

For models 5601P, 5603, 5621, 5623: 100°F (38°C).

For models 5602, 5604, 5622, 5624: 150°F (65.6°C).

Alarm temperature:

For models 5601P, 5603, 5621, 5623: 135°F (57°C).

For models 5602, 5604, 5622, 5624: 194°F (90°C).

Rate-of-Rise Threshold: 15°F (8.3°C) per minute (models 5601, 5602, 5621, 5622 only).

Operating Humidity Range: 5% to 95% RH noncondensing.

Input Terminals: non-polarized, accept 14 to 22 AWG (2.0 to 0.33 mm²).

Dimensions: diameter with mounting bracket: 4.57" (116 mm); height with mounting bracket: 1.69" (43 mm).

Weight: 6 oz. (170 grams).

Mounting Options: 3.5" (88.9 mm) octagonal backbox; 4" (101.6 mm) octagonal backbox; single-gang backbox; 4" (101.6 mm) square backbox with a square-to-round plaster ring.

ELECTRICAL SPECIFICATIONS

Operating Voltage	Contact Ratings (resistive)
6 - 125 VAC	3.0 A
6 - 28 VDC	1.0 A
125 VDC	0.3 A
250 VDC	0.1 A

Mechanical heat detector shall be a System Sensor 5600 Series model number _____, Listed to Underwriters Laboratories UL 521 for Heat Detectors for Fire Protective Signaling Systems. The detector shall be either a single-circuit or a dual-circuit type, normally open. The detector shall be rated for activation at either 135°F (57°C) or 194°F (90°C), and shall activate by means of a fixed-temperature thermal sensor, or a combination fixed-temperature/rate-of-rise thermal sensor. The rate-of-rise element shall be activated by a rapid rise in temperature, approximately 15°F (8.3°C) per minute. The detector shall include a reversible mounting bracket for mount-

ing to 3.5-inch (88.9 mm) octagonal, 4-inch (101.6 mm) octagonal, single gang, and 4-inch (101.6 mm) square backboxes with a square-to-round plaster ring. Wiring connections shall be made by means of SEMS screws that shall accommodate 14 – 22 AWG wire. The detector shall contain alphanumeric markings on the exterior of the housing to identify its tempera-

ture rating and activation method. The rate-of-rise element of combination fixed-temperature/rate-of-rise models shall be restorable, to allow for field-testing. The detectors shall include an external collector that shall drop upon activation to identify the unit in alarm.



Permitting and Inspections Department
Approved with Conditions

07/06/2018

ORDERING INFORMATION

Model*	Identification Method on Exterior	Circuit	Temperature Rating	Activation	UL Protected Spacing, 10' (3.048 m) Ceiling*
5601P	None	Single	135°F (57°C)	Fixed-Temperature/Rate-of-Rise	50 ft. x 50 ft. (15.24 m x 15.24 m)
5602	Lettering	Single	194°F (90°C)	Fixed-Temperature/Rate-of-Rise	50 ft. x 50 ft. (15.24 m x 15.24 m)
5603	Lettering	Single	135°F (57°C)	Fixed-Temperature	25 ft. x 25 ft. (7.62 m x 7.62 m)
5604	Lettering	Single	194°F (90°C)	Fixed-Temperature	25 ft. x 25 ft. (7.62 m x 7.62 m)
5621	Lettering	Dual	135°F (57°C)	Fixed-Temperature/Rate-of-Rise	50 ft. x 50 ft. (15.24 m x 15.24 m)
5622	Lettering	Dual	194°F (90°C)	Fixed-Temperature/Rate-of-Rise	50 ft. x 50 ft. (15.24 m x 15.24 m)
5623	Lettering	Dual	135°F (57°C)	Fixed-Temperature	25 ft. x 25 ft. (7.62 m x 7.62 m)
5624	Lettering	Dual	194°F (90°C)	Fixed-Temperature	25 ft. x 25 ft. (7.62 m x 7.62 m)

NOTE: Refer to NFPA 72 guidelines for spacing reductions when ceiling heights exceed 10 feet (3.048 m).

* Add an "A" to part number for ULC model.

WIRING DIAGRAMS

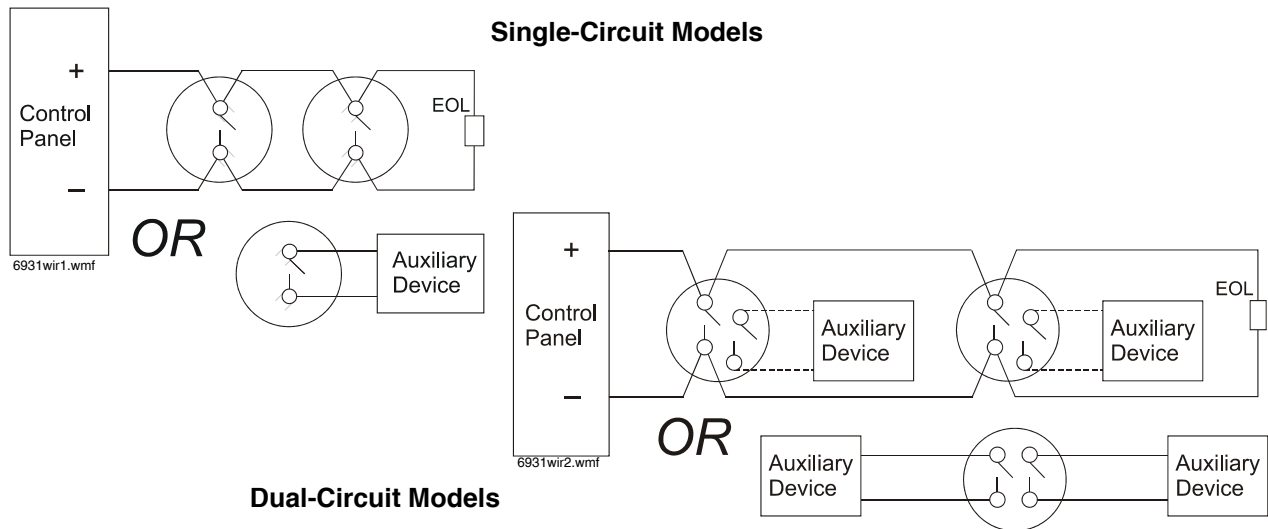

©2010 by Honeywell International Inc. All rights reserved. Unauthorized use of this document is strictly prohibited.



This document is not intended to be used for installation purposes. We try to keep our product information up-to-date and accurate. We cannot cover all specific applications or anticipate all requirements. All specifications are subject to change without notice.



For more information, contact Notifier. Phone: (203) 484-7161, FAX: (203) 484-7118. www.notifier.com



FCPS-24S6(C/E) & FCPS-24S8(C/E)

6- & 8-Amp 24-Volt Remote Power Supplies



07/06/2018

Power Supplies

General

The FCPS-24S6E (6-amp) and FCPS-24S8E (8-amp) are remote power supplies with battery charger. The FCPS-24S6/-24S8 may be connected to any 12 or 24 volt fire alarm control panel (FACP) or may be used as stand-alone supplies. Primary applications include notification appliance circuit (NAC) expansion (to support ADA requirements and NAC synchronization) or auxiliary power to support 24 volt system accessories. The FCPS-24S6/-24S8 provides regulated and filtered 24 VDC power to four notification appliance circuits configured as either four Class B (Style Y) or Class A (Style Z, with ZNAC-4 option module). Alternately, the four outputs may be configured as all non-resettable, all resettable or two non-resettable and two resettable. The FCPS-24S6/-24S8 also contains a battery charger capable of charging up to 18 AH batteries. FCPS-24S6C & FCPS-24S8C are ULC-listed.

NOTE: Unless otherwise specified, the terms FCPS-24S6 and FCPS-24S8 used in this document refers to the standard FCPS-24S6 and FCPS-24S8, FCPS-24S6C and FCPS-24S8C, the FCPS-24S6E and FCPS-24S8E

Features

- UL-Listed NAC synchronization using System Sensor, Wheelock, or Gentex “Commander²” appliances.
- Operates as a “sync-follower” or as a “sync-generator” (default). See note on page 2.
- Contains two fully-isolated input/control circuits - triggered from FACP NAC (NAC expander mode) or jumped permanently “ON” (stand-alone mode).
- Four Class B (Style Y) or four Class A (Style Z, with ZNAC-4 module) NACs.
- 6-amp (FCPS-24S6) or 8-amp (FCPS-24S8) full load output, with 3 amps maximum/circuit, in NAC expander mode (UL 864).
- 4-amp (FCPS-24S6) or 6-amp (FCPS-24S8) continuous output in stand-alone mode (UL 1481).
- Compatible with coded inputs; signals passed through.
- Optional power-supervision relay (EOLR-1).
- In stand-alone mode, output power circuits may be configured as: resettable, (reset line from FACP required), non-resettable, or a mix of two and two.
- Fully regulated and filtered power output - optimal for powering four-wire smoke detectors, annunciators, and other system peripherals requiring regulated/filtered power.
- Power-limiting technology meets UL power-limiting requirements.
- Form-C normally-closed trouble relay.
- Fully supervised power supply, battery, and NACs.
- Selectable earth fault detection.
- AC trouble report selectable for immediate 2-hour delay.
- Works with virtually any UL 864 fire alarm control which utilizes an industry-standard reverse-polarity notification circuit (including unfiltered and unregulated NAC power).
- Requires input trigger voltage of 9 - 32 VDC.
- Self-contained in compact, locking cabinet - 15”H x 14.5”W x 2.75”D (cm: 38.1H x 36.83W x 6.985D).



- Includes integral battery charger capable of charging up to 18 AH batteries. Cabinet capable of housing 7.0 AH batteries.
- Battery charger may be disabled via DIP switch for applications requiring larger batteries.
- Fixed, clamp-type terminal blocks accommodate up to 12 AWG (3.1mm²) wire.

Specifications

Primary (AC) Power:

- FCPS-24S6C/-24S8C: 120 VAC, 60 Hz, 3.2A maximum.
- FCPS-24S6E/-24S8E: 240 VAC, 50 Hz, 1.6A maximum.
- Wire Size: minimum #14 AWG (2.0mm²) with 600 V insulation.

Control Input Circuit:

- **Trigger Input Voltage:** 9 to 32 VDC.
- **Trigger Current:** 2.0 mA (16 - 32 V); Per Input: 1.0 mA (9 - 16 V).

Trouble Contact Rating:

5 A at 24 VDC.

Auxiliary Power Output: Specific application power 500 mA maximum.

Output Circuits:

- +24 VDC filtered, regulated.
- 3.0 A maximum for any one circuit.
- Total continuous current for all outputs (stand-alone mode):
 - FCPS-24S6: 4.0 A maximum.
 - FCPS-24S8: 6.0 A maximum.
- Total short-term current for all outputs (NAC expander mode):
 - FCPS-24S6: 6.0 A maximum.
 - FCPS-24S8: 8.0 A maximum.

Secondary Power (Battery) Charging Circuit:

- Supports lead-acid batteries only.



- Float-charge voltage: 27.6 VDC.
- Maximum current charge: 1.5 A.
- Maximum battery capacity: 18 AH.

Applications

Example 1: Expand notification appliance power an additional 6.0 A (FCPS-24S6) or 8.0 A (FCPS-24S8). Use up to four Class B (Style Y) outputs or four Class A (Style Z) outputs (using ZNAC-4). For example, the FACP notification appliance circuits will activate the FCPS when reverse-polarity activation occurs. Trouble conditions on the FCPS are sensed by the FACP through the notification appliance circuit.

Example 2: Use the FCPS to expand auxiliary regulated 24-volt system power up to 4.0 A (FCPS-24S6) or up to 6.0 A (FCPS-24S8). Both resettable and non-resettable power options are available. Resettable outputs are created by connecting the resettable output from the FACP to one or both of the FCPS inputs.

Example 3: Use addressable control modules to activate the FCPS instead of activating it through the FACP notification appliance circuits. This typically allows for mounting the FCPS at greater distances* away from the FACP while expanding system architecture in various applications.

For example, an addressable control module is used to activate the FCPS, and an addressable monitor module is used to sense FCPS trouble conditions. Local auxiliary power output from the FCPS provides power to the addressable control module.

**NOTE: Addressable FACP's are capable of locating control and monitor modules at distances of up to 12,500 feet (3,810 meters).*

Sync Follower/Generator Note

In some installations, it is necessary to synchronize the flash timing of all strobes in the system for ADA compliance. Strobes accomplish this by monitoring very short timing pulses on the NAC power which are created by the FACP. When installed at the end of a NAC wire run, the FCPS-24S6/-24S8 can track (i.e. "follow") the strobe synchronization timing pulses on the existing NAC wire run. This maintains the overall system flash timing of the additional strobes attaches to the FCPS.

When the FCPS-24S6/-24S8 is configured (via DIP switch settings) as a "sync follower," the FCPS's NAC outputs track the strobe synchronization pulses present at the FCPS's sync input terminal. The pulses originate from an upstream FACP or other power supply.

When the FCPS-24S6/-24S8 are configured (via DIP switch settings) as a "sync generator," the FCPS's sync input terminals are not used. Rather, the FCPS is the originator of the strobe synchronization pulses on the FCPS's NAC outputs. In "sync generator" mode, the sync type (System Sensor, Wheelock, or Gentex) is selectable via DIP switch settings.

Standards and Codes

The FCPS-24S6 and FCPS-24S8 comply with the following standards:

- **NFPA 72** National Fire Alarm Code.
- **UL 864** Standard for Control Units for Fire Alarm Systems (NAC expander mode).
- **UL 1481** Power Supplies for Fire Alarm Systems.

Agency Listings and Approvals

These listings and approvals apply to the modules specified in this document. In some cases, certain modules or applications may not be listed by certain approval agencies, or listing may be in process. Consult factory for latest listing status.

- **UL Listed:** S635, S674
- **ULC Listed:** S635 (FCPS-24S6C & FCPS-24S8C)
- **CSFM Approved:** 7315-0028:225
- **MEA:** 299-02-E
- **FM Approved**

Ordering Information

FCPS-24S6: 6.0 A, 120 VAC remote charger power supply. Includes main printed circuit board, transformers, enclosure (15"H x 14.5"W x 2.75"D [cm: 38.1H x 36.83W x 6.985D]), and installation instructions.

FCPS-24S6C: Same as above, ULC-listed.

FCPS-24S6R: Same as FCPS-24S6 with red enclosure.

FCPS-24S6E: 6.0 A, 240 VAC remote charger power supply. Includes main printed circuit board, transformers, enclosure (15"H x 14.5"W x 2.75"D [cm: 38.1H x 36.83W x 6.985D]), and installation instructions.

FCPS-24S8: 8.0 A, 120 VAC remote charger power supply. Includes main printed circuit board, transformers, enclosure (15"H x 14.5"W x 2.75"D [cm: 38.1H x 36.83W x 6.985D]), and installation instructions.

FCPS-24S8C Same as above, ULC-listed.

FCPS-24S8R: Same as FCPS-24S8 with red enclosure.

FCPS-24S8E: 8.0 A, 240 VAC remote charger power supply. Includes main printed circuit board, transformers, enclosure (15"H x 14.5"W x 2.75"D [cm: 38.1H x 36.83W x 6.985D]), and installation instructions.

ZNAC-4: Class A (Style Y) NAC option module.

EOLR-1: 12/24 VDC end-of-line relay for monitoring four-wire smoke detector power.

BAT-1270: Battery, 12-volt, 7.0 AH (two required, see BAT Series data sheet DN-6933).

System Sensor® and NOTIFIER® are registered trademarks of Honeywell International Inc.

©2013 by Honeywell International Inc. All rights reserved. Unauthorized use of this document is strictly prohibited.



This document is not intended to be used for installation purposes.
We try to keep our product information up-to-date and accurate.
We cannot cover all specific applications or anticipate all requirements.
All specifications are subject to change without notice.



Made in the U.S.A.

For more information, contact Notifier. Phone: (203) 484-7161, FAX: (203) 484-7118.
www.notifier.com



BAT Series Batteries

Sealed Lead-Acid or Gell Cell

**Power Supplies**

General

BAT Series Batteries feature a new part-numbering/listing system — providing an improved method of delivery for NOTIFIER-approved sealed lead-acid batteries for all your fire alarm system needs. Multiple brands of batteries are now offered under generic part numbers, reducing backorder situations and permitting us to deliver these products in a more timely fashion. NOTIFIER has approved the multiple brands listed below as possible product shipped for a given part number. Please note that any incoming orders for “PS Series” batteries will be converted to the equivalent BAT Series part numbers.



6933cov.jpg

Features

- Provide secondary power for control panels.
- Sealed and maintenance-free.
- Overcharge protected.
- Easy handling with leakproof construction.
- Ruggedly constructed, high-impact case (ABS, polystyrene, or polypropylene, depending on models).
- Long service life.
- Compact design.

Agency Listings and Approvals

The listings and approvals below apply to BAT Series Batteries. In some cases, certain modules may not be listed by certain approval agencies, or listing may be in process. Consult factory for latest listing status.

- **UL Recognized Components:** files MH19884 (*B & B Battery*), MH20567 (*UPG, previously Jolt*), MH20845 (*Power-Sonic*).

Part Number Reference

CURRENT Part Number	BATTERY DESCRIPTION	ALTERNATES APPROVED: manufacturers and P/Ns shipped under BAT P/Ns
BAT-1250	12 V, 5 AH, sealed.	BP5-12 (B&B Battery); PS-1250 (Power-Sonic); SA1250 (Jolt) to be replaced with UB1250 (UPG).
BAT-1250	12 V, 5 AH, sealed.	BP5-12 (B&B Battery); PS-1250 (Power-Sonic); SA1250 (Jolt) to be replaced with UB1250 (UPG).
BAT-1270	12 V, 7 AH, sealed.	BP7-12 (B&B Battery); PS-1270 (Power-Sonic); SA1272 (Jolt) to be replaced with UB1270 (UPG).
BAT-12120	12 V, 12 AH, sealed.	BP12-12 (B&B Battery); PS-12120 (Power-Sonic); SA12120 (Jolt) to be replaced with UB12120 (UPG).
BAT-12180	12 V, 18 AH, sealed.	PS-12180 (Power-Sonic); SA12180 (Jolt) to be replaced with UB12180 (UPG).
BAT-12180	12 V, 18 AH, sealed.	PS-12180 (Power-Sonic); SA12180 (Jolt) to be replaced with UB12180 (UPG).
BAT-12260	12 V, 26 AH, sealed.	BP26-12 (B&B Battery); PS-12260 (Power-Sonic); SA12260 (Jolt) to be replaced with UB12260 (UPG).
BAT-12550	12 V, 55 AH, sealed.	PS-12550 (Power-Sonic); XSA12550 (Jolt) to be replaced with UB12550 (UPG).
BAT-12550	12 V, 55 AH, sealed.	PS-12550 (Power-Sonic); XSA12550 (Jolt) to be replaced with UB12550 (UPG).
BAT-121000	12 V, 100 AH, gell cell.	PS-121000 (Power-Sonic); XSA121000A (Jolt) to be replaced with UB121000 (UPG).



POWER-SONIC

Part Number Reference

MODEL	Nominal Voltage V	Nominal Capacity @ 20 hr. rate A.H.	Discharge Current @20 hr. rate mA	DIMENSIONS									
				Width		Depth		Height		Height over terminal		Weight	
				in.	mm	in.	mm	in.	mm	in.	mm	lb.	kg.
PS-1250	12	5	250	3.54	90	2.76	70	4.02	102	4.21	107	4.1	1.9
PS-1270	12	7	325	5.94	151	2.56	65	3.7	94	3.86	98	5.7	2.6
PS-12120	12	12	600	5.94	151	3.86	98	3.7	94	3.86	98	8.8	4
PS-12180	12	18	875	7.13	181	2.99	76	6.57	167	6.57	167	12.8	5.8
PS-12250	12	25	1300	6.89	175	6.54	166	4.92	125	4.92	125	18.7	8.5
PS-12550	12	55	3000	10.25	260	6.6	168	8.2	208	9.45	240	39.7	18
PS-121000	12	100	5000	12	305	6.6	168	8.2	208	9.45	240	65.7	29.8

Characteristic Discharge Curves

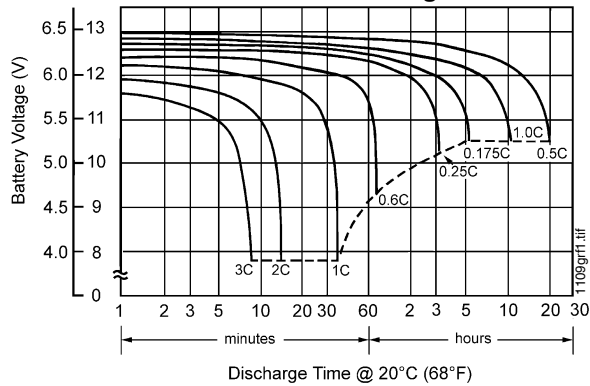

Effect of Temperature on Capacity

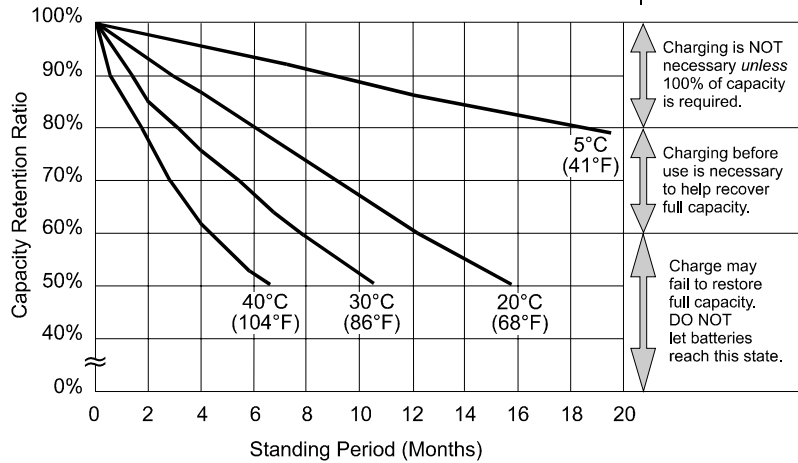
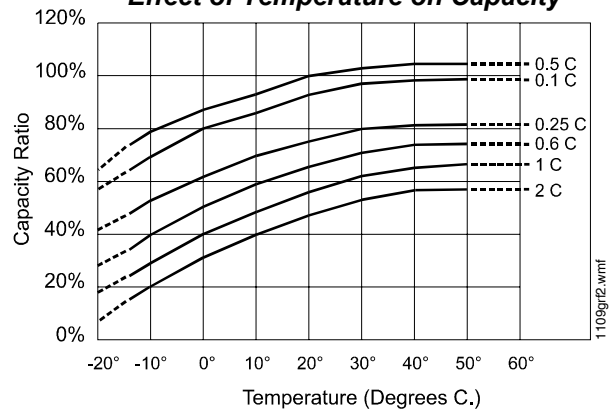

**at left:
PS-121000
Shelf-Life
and Storage**

Charging is NOT necessary unless 100% of capacity is required.
Charging before use is necessary to help recover full capacity.
Charge may fail to restore full capacity. DO NOT let batteries reach this state.

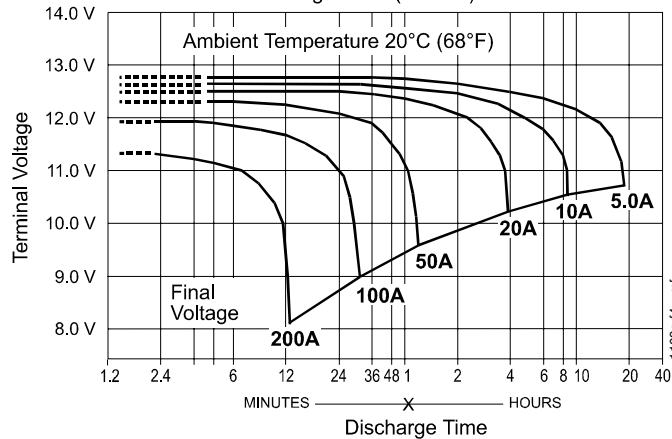

**at left:
PS-121000
Discharge
Characteristics**



GENTEX CORPORATION

07/26/2018

Commander³ Series Selectable Candela Evacuation Signals

Applications

The Commander³ Series is a low profile strobe and horn/strobe combination that offers dependable audible and visual alarms and the absolute lowest current available.

The GE3 Series 24VDC offers tamperproof field selectable candela options of 15, 30, 60, 75, and 110 candela. The 12VDC offers tamperproof field selectable candela options of 15, 30, 60, and 75 candela.

The Commander³ Series horn offers a continuous or synchable temporal three in 2400Hz and mechanical tone, a chime and whoop tone. All tones are easy for the professional to change in the field by the use of switches.

The GE3 Series has a minimal operating current and has a minimum flash rate of 1Hz regardless of input voltage.

The Commander³ Series is shipped with a standard 4" metal mounting plate which incorporates the popular Super-Slide[®] feature that allows the installer to easily test for supervision. The product also features a locking mechanism which secures the product to the bracket without any screws showing.

The Commander³ also features the patented Checkmate[®] - Instant Voltage Verification feature which allows the installer to check the voltage drop draw and match it to the blueprint.

The GE3 Series appliances are ANSI/UL 464 and ANSI/UL 1971, listed for use with fire protective systems and are warranted for three years from date of purchase.

Standard Features

- Nominal voltage 12VDC and 24VDC
- 24VDC units have field selectable candela options of 15, 30, 60, 75 & 110
- 12VDC units have field selectable candela options of 15, 30, 60 & 75
- GEH horn is available in 12VDC or 24VDC
- Unit Dimensions: 5" (12.7 cm) high x 4.5" (11.43 cm) wide x 2.5" (6.35 cm) deep
- Super-Slide[®] Bracket - Ease of Supervision Testing
- Checkmate[®] - Instant Voltage Verification
- Synchronize strobe and/or horn with Gentex AVSM Control Module
- Prewire entire system, install mounting bracket, then install signals
- Documented lower installation and operating costs
- Input terminals accept 12 to 18 AWG
- Switch selection for high or low dBA
- Switch for chime, whoop, mechanical and 2400Hz tone
- Tamperproof re-entrant style grill
- Switch for continuous or temporal 3 tone (not available on whoop tone)
- Surface mount with the GSB (Gentex Surface Mount Box)
- Silence audible while visual appliance will remain flashing (for use in accepted jurisdictions)
- Faceplate available in red or off-white

GEC3/GES3 12 & 24 VDC SERIES



Product Listings

SIGNALING



- ANSI/UL 464 & ANSI/UL 1971 Listed
- CSFM: 7135-0569:122 (GEC3-24 & GEH-24)
7125-0569:123 (GES3-24)
7125-0569:129 (GES3-12)
7135-0569:130 (GEC3-12 & GEH-12)
- MEA: 285-91-E (GEC3-24 & GES3-24)
580-06-E (GEC3-12 & GES3-12)

Patents

- 7,375,617 May 20, 2008

Product Compliance

- NFPA 72
- Americans with Disabilities Act (ADA)
- IBC/IFC/IRC
- Quality Management System is certified to: ISO 9001:2008



ASSEMBLED IN THE USA



GEH 12VDC or 24VDC Low Profile Evacuation Horn

Model Number	Part Number	Nominal Voltage	Reverberant dBA at 10ft., per ANSI/UL 464	In Anechoic Room dBA at 10ft.
GEH12-R	904-1239-002	12VDC	62-82	100
GEH12-W	904-1241-002	12VDC	62-82	100
GEH24-R	904-1205-002	24VDC	62-82	100
GEH24-W	904-1207-002	24VDC	62-82	100

GES3 12VDC or 24VDC Selectable Candela, Low Profile Evacuation Strobe

Model Number	Part Number	Nominal Voltage	Candela (ANSI/UL 1971)
GES3-12WR	904-1235-002	12 VDC	15, 30, 60, 75
GES3-12WW	904-1237-002	12 VDC	15, 30, 60, 75
GES3-24WR	904-1321-002	24 VDC	15, 30, 60, 75, 110
GES3-24WW	904-1319-002	24 VDC	15, 30, 60, 75, 110

GEC3 12VDC or 24VDC Selectable Candela, Low Profile Evacuation Horn/Strobe

Model Number	Part Number	Nominal Voltage	Candela (ANSI/UL 1971)	Reverberant dBA at 10ft., per ANSI/UL 464	In Anechoic Room dBA at 10ft.
GEC3-12WR	904-1231-002	12 VDC	15, 30, 60, 75	62-82	100
GEC3-12WW	904-1233-002	12 VDC	15, 30, 60, 75	62-82	100
GEC3-24WR	904-1317-002	24 VDC	15, 30, 60, 75, 110	62-82	100
GEC3-24WW	904-1315-002	24 VDC	15, 30, 60, 75, 110	62-82	100

GE3 Product Strobe Current Ratings (mA)				
	12 VDC (8-17.5 Volts)		24 VDC (16-33 Volts)	
Candela	12VDC	UL Max ¹	24VDC	UL Max ¹
15cd	106mA	92mA	30mA	42mA
30cd	131mA	141mA	35mA	58mA
60cd	186mA	260mA	66mA	97mA
75cd	237mA	312mA	80mA	116mA
110cd			103mA	161mA

Model Designations:

W = Wall mount

R = Red Faceplate W = White Faceplate

All units are available in plain (no lettering).

Plain units are non-returnable.

ALERT bezel available for order

AGENT bezel available for order

GE3-12 Product Horn Current Ratings			
Horn Mode	Horn Decibel Levels		Regulated 12VDC Max. Operating @ High Setting (mA)
	Minimum SPL at 10ft., per ANSI/UL 464 (HIGH)	Minimum SPL at 10ft., per ANSI/UL 464 (LOW)	
Temp 3 2400Hz	76 dBA	69* dBA	29mA
Temp 3 Mechanical	75 dBA	68* dBA	26mA
Temp 3 Chime	62* dBA	60* dBA	13mA
Continuous 2400Hz	79 dBA	74* dBA	29mA
Continuous Mechanical	78 dBA	72* dBA	26mA
Continuous Chime	63* dBA	61* dBA	13mA
Whoop	78 dBA	71* dBA	55mA

GE3-24 Product Horn Current Ratings			
Horn Mode	Horn Decibel Levels		Regulated 24VDC Max. Operating @ High Setting (mA)
	Minimum SPL at 10ft., per ANSI/UL 464 (HIGH)	Minimum SPL at 10ft., per ANSI/UL 464 (LOW)	
Temp 3 2400Hz	78 dBA	71* dBA	28mA
Temp 3 Mechanical	76 dBA	70* dBA	25mA
Temp 3 Chime	70* dBA	66* dBA	15mA
Continuous 2400Hz	81 dBA	74* dBA	28mA
Continuous Mechanical	80 dBA	72* dBA	25mA
Continuous Chime	70* dBA	66* dBA	15mA
Whoop	82 dBA	69* dBA	56mA

NOTES:

- Operating temperature: 32° to 120°F (0° to 49°C). The GEC3 and GES3 Series is **not** listed for outdoor use.
- For nominal and peak current across ANSI/UL regulated voltage range for filtered DC power and unfiltered (FWR [Full Wave Rectified]) power, see installation manual. 12VDC models are DC only.
- Gentex does not recommend using a coded or pulsing signaling circuit with any of our strobe products (see Technical Bulletin Number 014).**
- The sound output for the temporal 3 tone is rated lower since the time the horn is off is averaged into the sound output rating. While the horn is producing a tone in the temporal 3 mode its sound pressure is the same as the continuous mode.
- * Operating the horn in this mode at this voltage will result in not meeting the minimum ANSI/UL 464 reverberant sound level required for public mode fire protection service. These settings are acceptable only for private mode fire alarm use. Use the high dBA setting for public mode application (not applicable when using the chime tone. The chime tone is always private mode).

¹ RMS current ratings are per ANSI/UL average RMS method. ANSI/UL max current rating is the maximum RMS current within the listed voltage range (16-33VDC for 24VDC units) (8-17VDC for 12VDC units). For strobes the UL max current is usually at the minimum listed voltage (16VDC for 24VDC units) (8VDC for 12VDC units). For audibles the max current is usually at the maximum listed voltage. For unfiltered FWR ratings, see installation manual.



Tone Switch Locations

TONE	SWITCH POSITION		
	3	4	5
Mechanical Temporal 3	ON	ON	ON
Mechanical - Continuous	OFF	ON	ON
2400Hz - Temporal 3	ON	OFF	ON
2400Hz - Continuous	OFF	OFF	ON
Chime - Temporal 3	ON	ON	OFF
Chime - Continuous	OFF	ON	OFF
Whoop	ON	OFF	OFF
Whoop	OFF	OFF	OFF

NOTE:

- Switch Positions 1 and 2 in the OFF position to select isolated horn and strobe power inputs
- Switch Position 6 ON = HIGH dBA
- Switch Position 6 OFF = LOW dBA

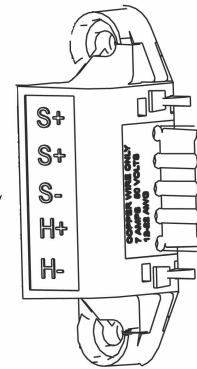
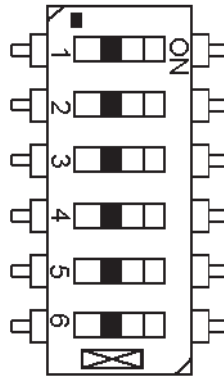

Gentex Super-Slide® Mounting Bracket

Allows the installer to pre-wire the system, test for system supervision, remove the signal head until occupancy, switch out Gentex signals without changing mounting brackets and has locking edge connector for snap-in-place installation.

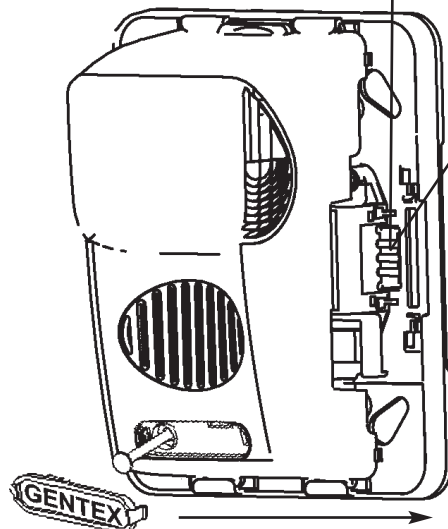

Gentex Checkmate® Instant Voltage Verification

It is often necessary to confirm the voltage drop along a line of devices. The access holes are provided in the back of the terminal block to allow the voltage to be measured directly without removing the device. Typically this would be done at the end of the line to confirm design criteria. Most measurements will be taken using the S+ and S- locations although access is provided to other locations.

NOTE: Care should be taken to not short the test probes.

Candela selection slider switch. Depress center and slide switch to desire brightness level.

Break off pin and insert into hole at the bottom of the selector to lock candela setting. Signal must be removed from bracket and pin pushed forward from backside out of hole to change candela.

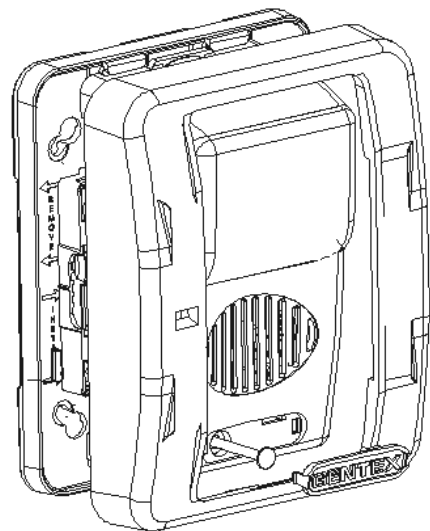
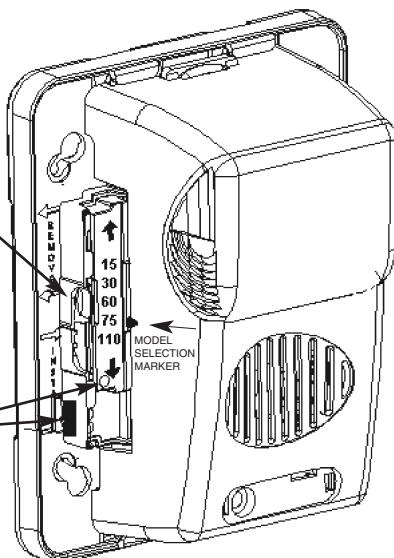

To remove bezel, grip both sides of bezel and pull in a downward and outward motion.



GEC3/GES3 12 & 24 VDC SERIES

Conventional Wiring Diagrams for Emergency Notification Evacuation Series

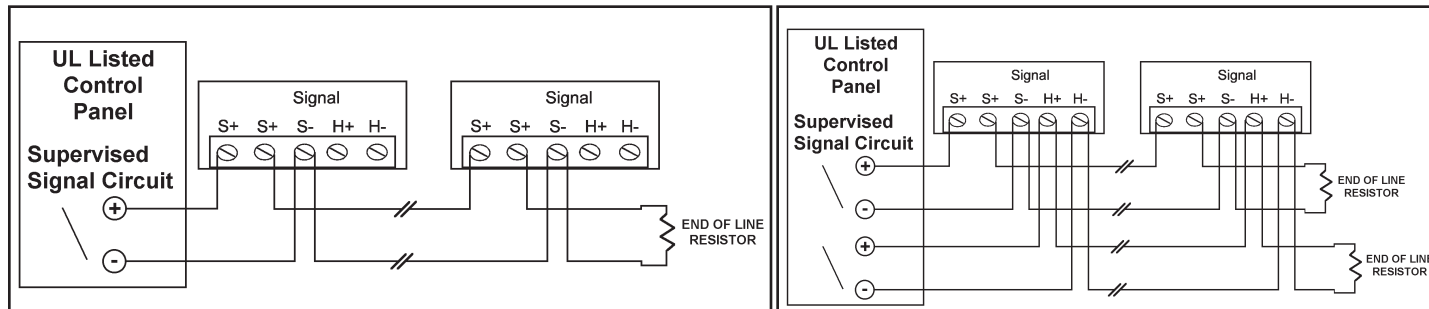

NOTES:

- All strobes are designed to flash as specified with continuous applied voltage. Strobes should not be used on coded or pulsing signaling circuits. However, use of the Gentex AVSM control module or Gentex synchronization protocol is permitted to synchronize the strobe, horn and/or mute the horn. See Technical Bulletin 014 for additional information.
- FOR SYNCHRONIZATION WIRING INFORMATION, REFERENCE AVSM CONTROL MODULE DATA SHEET (551-0031) AND/OR AVSM CONTROL MODULE MANUAL (550-0284) FOR SYNCHRONIZATION MODULE WIRING DIAGRAMS. AVSM CONTROL MODULE DATA SHEET AND MANUAL CAN BE OBTAINED AT <http://www.gentex.com> OR CALL GENTEX CORPORATION AT 1-800-436-8391.
- When synchronizing the GE3 12VDC Series, the Gentex AVSM control module or Gentex synchronization protocol **MUST** be used.

Architect & Engineering Specifications

The audible and/or visible signal shall be Gentex GEH, GES3, GEC3 Series or approved equal and shall be listed by Underwriters Laboratories, Inc. per ANSI/UL 1971 and/or ANSI/UL 464. The notification appliance shall also be listed with Factory Mutual Listing Service (FM) and the California State Fire Marshal (CSFM).

The notification appliance (combination audible/visible) shall produce a peak sound output of 100dBA or greater at 12VDC or 24VDC as measured in an anechoic chamber. The signaling appliance shall also have the capability to silence the audible signal while leaving the visible signal energized with the use of a single pair of power wires. Additionally, the user shall be able to select either continuous or temporal tone output with the temporal signal having the ability to be synchronized.

Unit shall be capable of being installed so that any unauthorized attempt to change the candela setting will result in a trouble signal at the fire alarm control panel.

The audible/visible and visible signaling appliance shall also maintain a minimum flash rate of 1Hz or up to 2Hz regardless of power input voltage. The strobe appliance shall have an operating current of 42mA or less at 24VDC for the 15Cd strobe circuit and 92mA or less at 12VDC for the 15Cd strobe circuit.

The appliance shall be polarized to allow for electrical supervision of the system wiring. The unit shall be provided with a mounting bracket with terminals and barriers for input/output wiring and be able to mount to a single gang or double gang box or double workbox without the use of an adapter plate. The unit shall have an input voltage range of 16-33 volts with either direct current or full wave rectified power for 24VDC models or a voltage range of 8-17.5 volts for 12VDC models.

The appliance shall be capable of testing supervision without disconnecting wires, verify voltage without removing unit and be capable of mounting to a surface back box.

24 units per carton
28 pounds per carton



Fire Protection Products Group • www.gentex.com
10985 Chicago Drive • Zeeland, Michigan 49464
616.392.7195 • 1.800.436.8391 • 616.392.4219 Fax

Gentex Corporation reserves the right to make changes to the product data sheet at their discretion.

Important Notice:

These materials have been prepared by Gentex Corporation ("Gentex") for informational purposes only, are necessarily summary, and are not purporting to serve as legal advice and should not be used as such. Gentex makes no representations and warranties, express or implied, that these materials are complete and accurate, up-to-date, or in compliance with all relevant local, state and federal laws, regulations and rules. The materials do not address all legal considerations as there is inevitable uncertainty regarding interpretation of laws, regulations and rules and the application of such laws, regulations and rules to particular fact patterns. Each person's activities can differently affect the obligations that exist under applicable laws, regulations or rules. Therefore, these materials should be used only for informational purposes and should not be used as a substitute for seeking professional legal advice. Gentex will not be responsible for any action or failure to act in reliance upon the information contained in this material.

551-0050-06



07/06/2018



System Power Requirements

FCPS-24s8 Power Supply

Protected Premises: <u>Poke Pop</u>	Date: <u>6/20/2018</u>
Address: <u>658 Congress Street</u>	
City: <u>Portland</u> State: <u>Maine</u>	Zip: <u>04101</u>
Prepared By: <u>Norris Inc.</u>	Phone: <u>1-800-370-3473</u>
Address: <u>2257 West Broadway</u>	Email: info@norrisinc.com
City: <u>South Portland</u> State: <u>Maine</u>	Zip: <u>04106</u>

AC Branch Current Requirements 3.20 AMPS @ 120 VAC

Current required by source to power the fire alarm system.

Primary Standby Load 0.09 Amps

Current load on the primary power supply during non-alarm conditions.

Primary Alarm Load 0.43 Amps

Current load on the primary power supply during alarm conditions.

Secondary Load Requirements 1.92 Amp Hours

Total Secondary Load from the calculation table below.

Current Draw		Time (hours)	Total (AH)
Secondary Standby Load 0.065 A	x	Required Standby Time	
		24 hours	1.56
Secondary Alarm Load 0.429 A	x	Required Alarm Time (hours)	
		0.084 hours	0.04
Total Secondary Load			1.60
Derating factor			x 1.2
Secondary Load Requirements			1.92

AH

Battery Selection 7 Amp Hours

Select batteries from the list below.

7 AH BAT-1270 Battery (12 volt)

- Two
- Four (two 12VDC sets in parallel)



07/06/2018

Battery Distribution Chart

Shows amp-hour distribution of your selections.

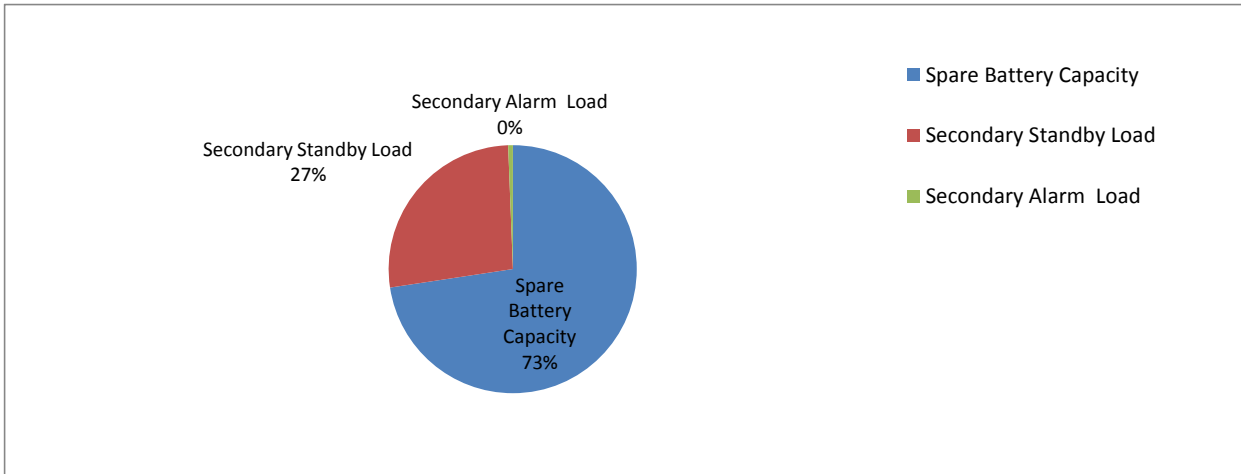

Comments

1. Batteries will fit in the FACP cabinet.
2. Selected battery size meets secondary load requirements.
3. The selected batteries (7AH) are within the charger range of this power supply (7-18AH).

Spare Battery Capacity	5.08	Battery Selection (AH) - Secondary Load Requirements (AH)
Secondary Standby Load	1.87	Secondary Standby Load (AH) * Derating Factor
Secondary Alarm Load	0.04	Secondary Alarm Load (AH) * Derating Factor



07/06/2018

NOTIFICATION APPLIANCE CIRCUIT VOLTAGE DROPS												
658 Congress St.												
Portland, Maine												
PANEL	CIRCUIT	WIRE GAUGE	LENGTH	CURRENT DRAW	VOLTAGE DROP	VOLTAGE LOSS	END VOLTAGE @ 24.0VDC		END VOLTAGE @ 20.4VDC		CIRCUIT LOAD	
FCPS #1	NAC 1	14	98FT	0.2A	0.099	VDC	0.41%	23.901	VDC	20.301	VDC	7%
FCPS #1	NAC 2	14	98FT	0.084A	0.042	VDC	0.17%	23.958	VDC	20.358	VDC	3%
FCPS #1: 0.284A/8A Spare Capacity: 96%												
Calculated @ Maximum Distance/Current												



SYMBOL LEGEND

DEVICES	NOTIFICATION
SMOKE DETECTOR	HORN STROBE
PULL STATION	STROBE
HEAT DETECTOR	XX = CANDELA RATING

WIRE LEGEND

2 COND 16 AWG TWISTED PAIR FPL CABLE
4 COND 14 AWG FPL CABLE

INSTALLATION NOTES:

FIELD WIRING SHALL BE INSTALLED FOLLOWING THE CURRENT EDITION OF NFPA 70: NATIONAL ELECTRIC CODE(2014), ALL APPLICABLE MUNICIPAL, COUNTY, & STATE CODES, REQUIREMENTS, AND REGULATIONS, AS WELL AS ALL MANUFACTURER GUIDELINES FOR INSTALLATION.

CONTROL PANELS, DEVICES, AND ALL OTHER SYSTEM COMPONENTS SHALL BE INSTALLED FOLLOWING THE CURRENT EDITION OF NFPA 72: NATIONAL FIRE ALARM AND SIGNALING CODE(2013), ALL APPLICABLE MUNICIPAL, COUNTY, & STATE CODES, REQUIREMENTS, AND REGULATIONS, AS WELL AS ALL MANUFACTURER GUIDELINES FOR INSTALLATION.

THE INSTALLER SHALL FOLLOW CORRECT CONDUCTOR POLARITY, INDICATED CIRCUIT DIVISIONS, PROPER GROUNDING AND SHIELDING WITHOUT EXCEPTION. IMPROPER INSTALLATION CAN RESULT IN INTERFERENCE, TRANSIENT VOLTAGE, OR SHORT CIRCUITS CAUSING UNDESIRABLE OPERATION OR DAMAGE TO THE CONTROL PANEL, DEVICES AND ANY OTHER INTEGRATED COMPONENTS.

THE GAUGE OF WIRE USED FOR THE SLC LOOP (IDENTIFIED AS "A" ON THIS PRINT), SHALL BE DETERMINED BY THE INSTALLER FOLLOWING GUIDELINES AND LIMITATIONS SET FORTH BY THE MANUFACTURER (NOTIFIER DOCUMENT #51253, INTELLIGENT CONTROL PANEL SLC WIRING MANUAL). THE SLC WIRING RISER IS SHOWN DIAGRAMMATICALLY ONLY TO ALLOW FOR VARIANCES IN ACTUAL WIRE DISTANCE, DEVICE PLACEMENT AND STRUCTURAL OR ENVIRONMENTAL REQUIREMENTS.

ANY T-TAPPING OF SLC WIRING SHALL FOLLOW ALL REQUIREMENTS IN NOTIFIER DOCUMENT #51253, INTELLIGENT CONTROL PANEL SLC WIRING MANUAL.

WIRE FOR THE NOTIFICATION APPLIANCE CIRCUITS (IDENTIFIED AS "B" ON THIS PRINT), SHALL FOLLOW THE SPECIFIC REQUIREMENTS OF THE WIRING LEGEND.

THIS SYSTEM MEETS NFPA REQUIREMENTS FOR OPERATION AT 32-120°F AND A RELATIVE HUMIDITY OF 91-95% AT 87-93°F. HOWEVER, THE USEFUL LIFE OF THE SYSTEM'S STANDBY BATTERIES AND THE ELECTRONIC COMPONENTS MAY BE ADVERSELY AFFECTED BY EXTREME TEMPERATURE RANGES AND HUMIDITY. THEREFORE, IT IS RECOMMENDED THAT THIS SYSTEM AND ITS PERIPHERALS BE INSTALLED IN AN ENVIRONMENT WITH A NORMAL ROOM TEMPERATURE OF 60-80°F.

END OF LINE DEVICES MUST BE INSTALLED IN AN EASILY ACCESSIBLE LOCATION AND CLEARLY MARKED OR LABELED.

DESIGN NOTES:

SYSTEM DESIGN PERFORMANCE AND COMPLIANCE WITH ALL APPLICABLE CODES AND REQUIREMENTS IS THE RESPONSIBILITY OF THE DESIGNING ENGINEER. PROPER INSTALLATION OF THIS SYSTEM AND ITS COMPONENTS IS THE RESPONSIBILITY OF THE INSTALLING CONTRACTOR. ANY ALTERATIONS, CHANGES, OR DEFICIENCIES MUST BE BROUGHT TO THE ATTENTION OF THE DESIGNING ENGINEER.

NORRIS INC. ASSUMES NO RESPONSIBILITY FOR ERRORS IN SYSTEM DESIGN OR INSTALLATION, AS WELL AS ANY COSTS ASSOCIATED WITH CORRECTING THESE ERRORS, IF ANY EXIST, UNLESS SYSTEM DESIGN OR INSTALLATION WAS PERFORMED BY NORRIS INC.

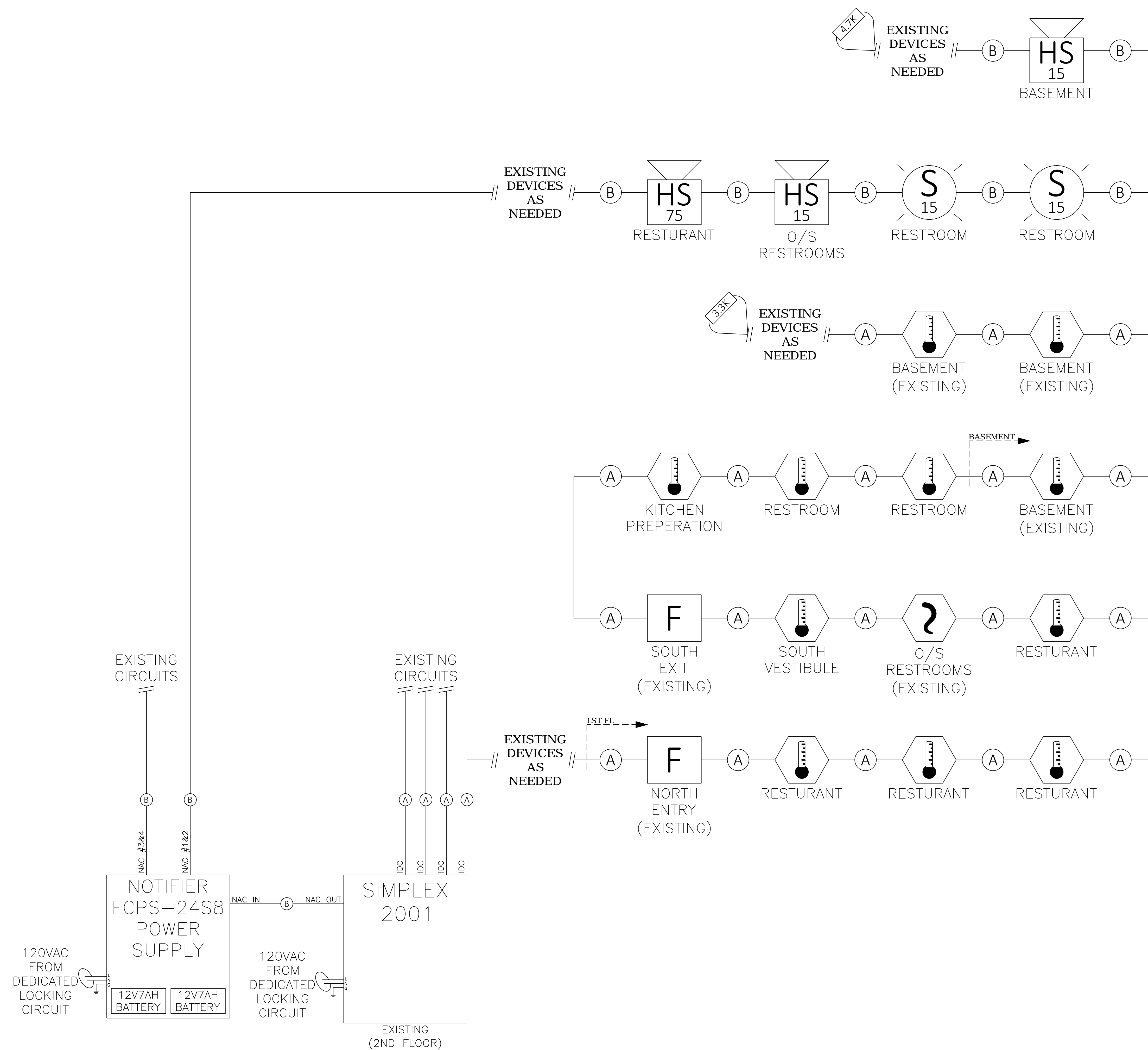

REVISION 1: SUBMITTAL 06/20/2018

FIRE ALARM WIRING RISER

PROJECT NUMBER: 329875SP SCALE: NONE

PROJECT: DRAWN BY:

POKE POP
658 CONGRESS ST.
PORTLAND, MAINE 04101

JAB

CHECKED BY:

JS

SHEET:

Norris Inc.

2257 BROADWAY

SOUTH PORTLAND, MAINE

FA-01