

FILE PATH: P:\2012\143\Elm Terrace\CAD\DWG\FA-701.dwg
LAST PRINTED: 3/13/2012 8:41:59 AM
LAST SAVED BY: CLORION

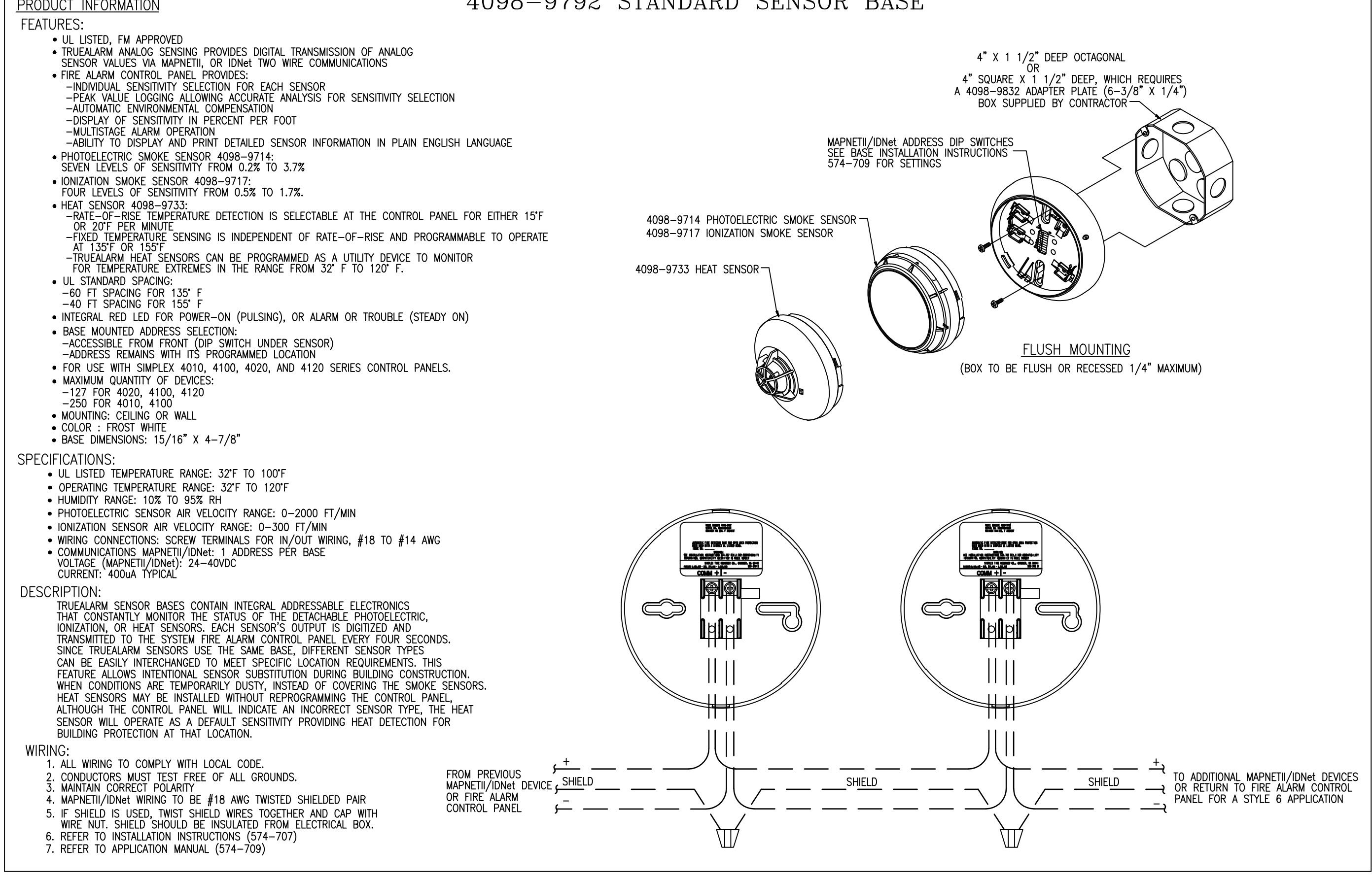
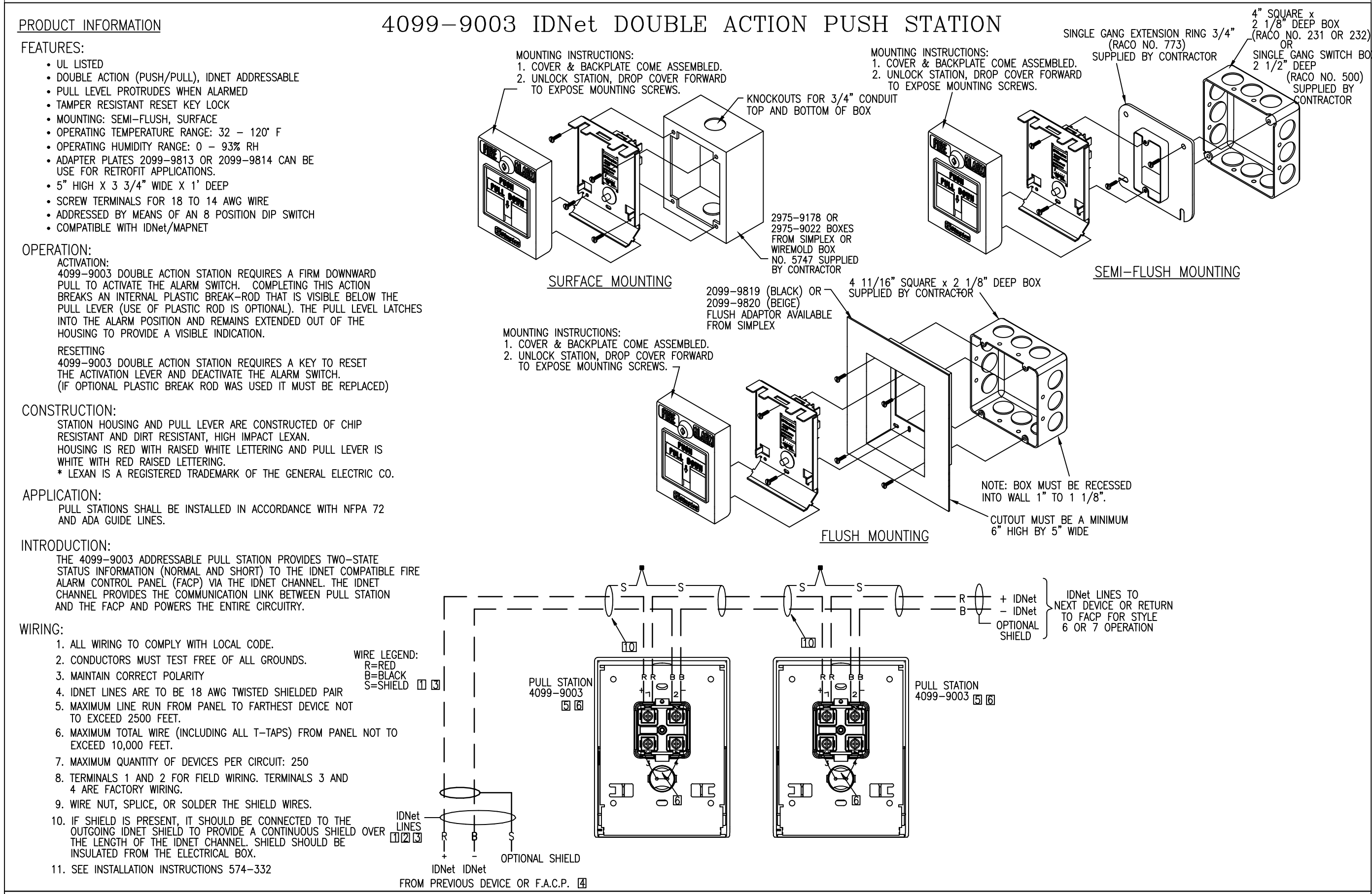
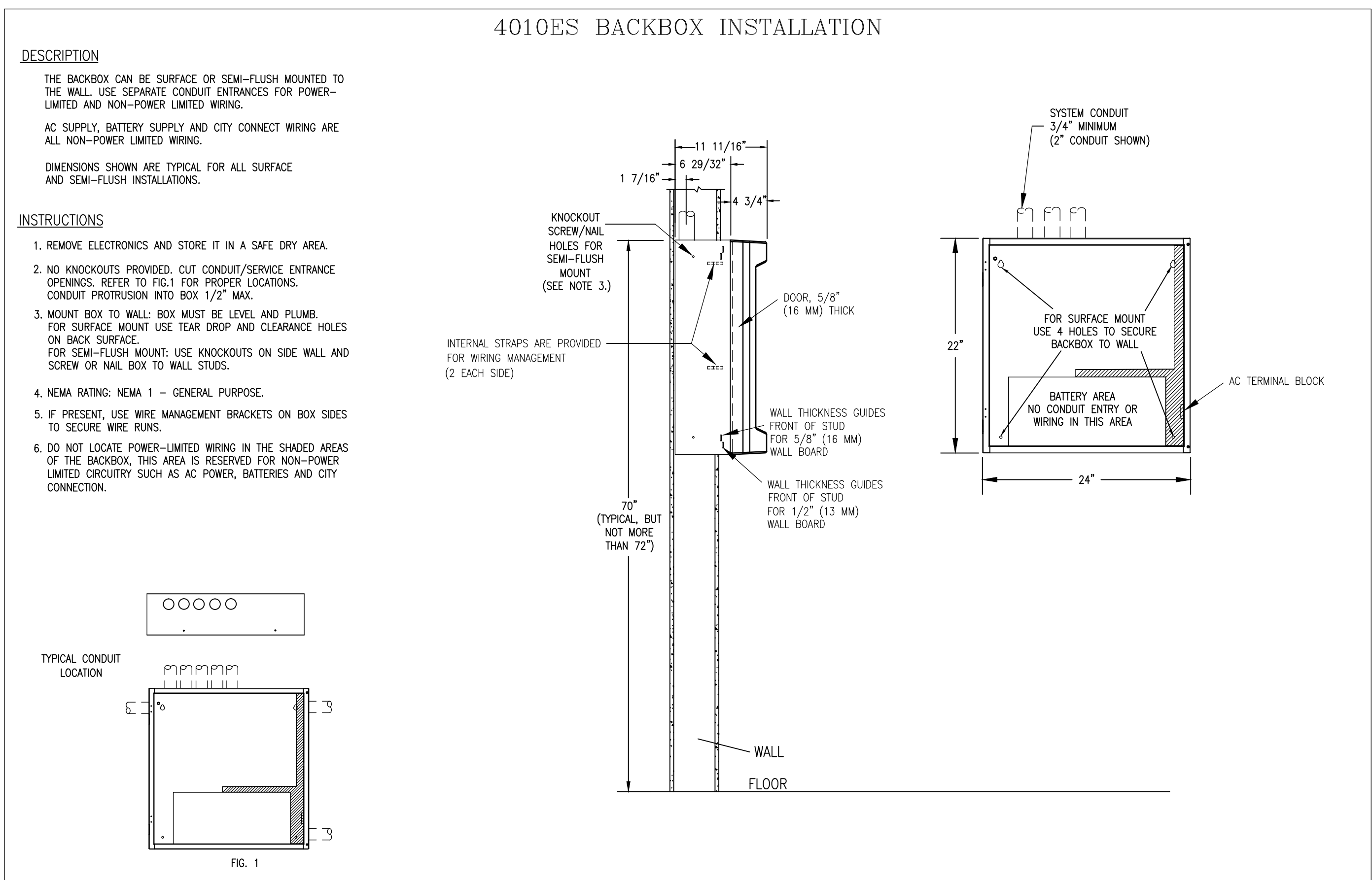
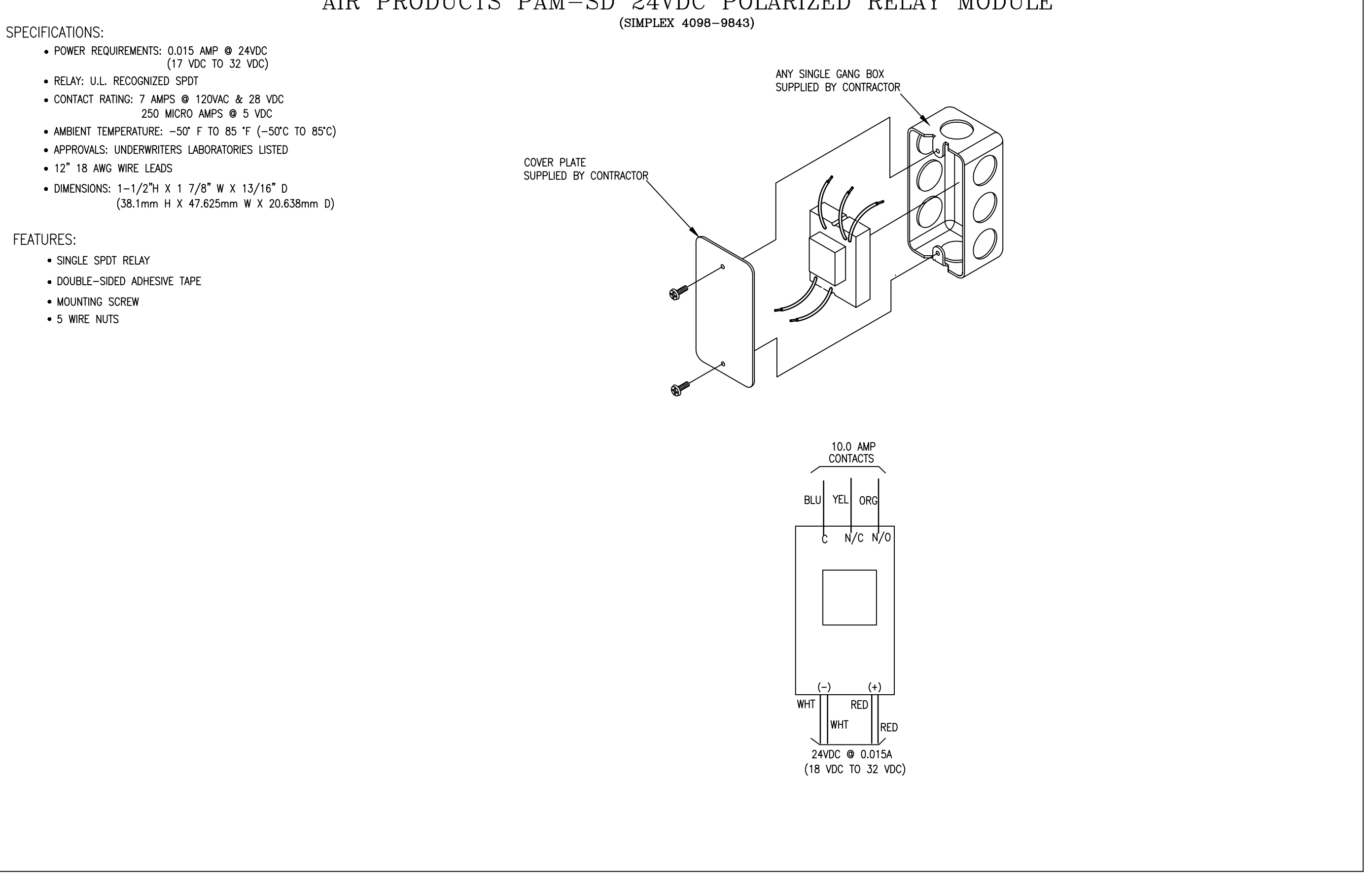
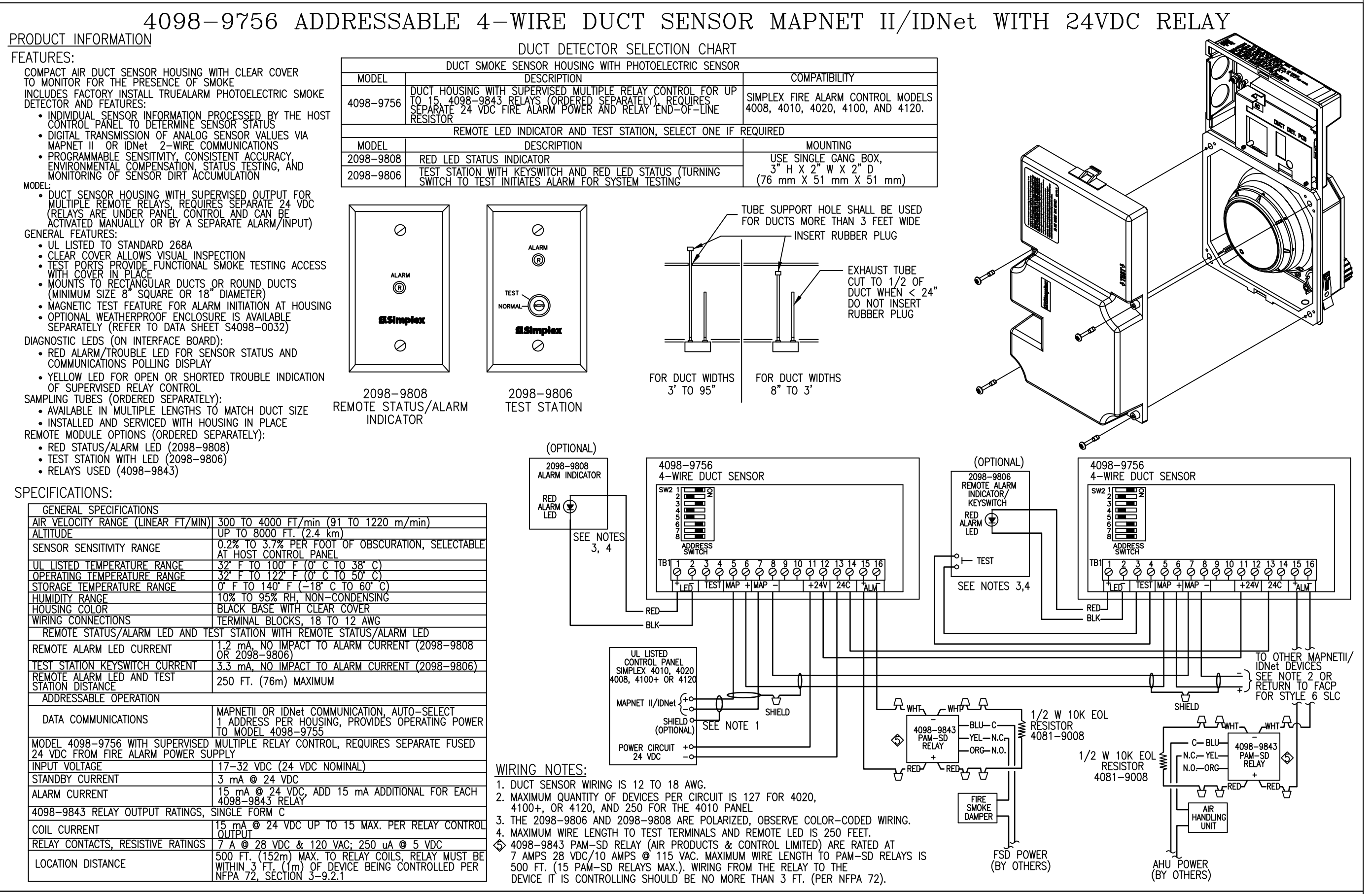
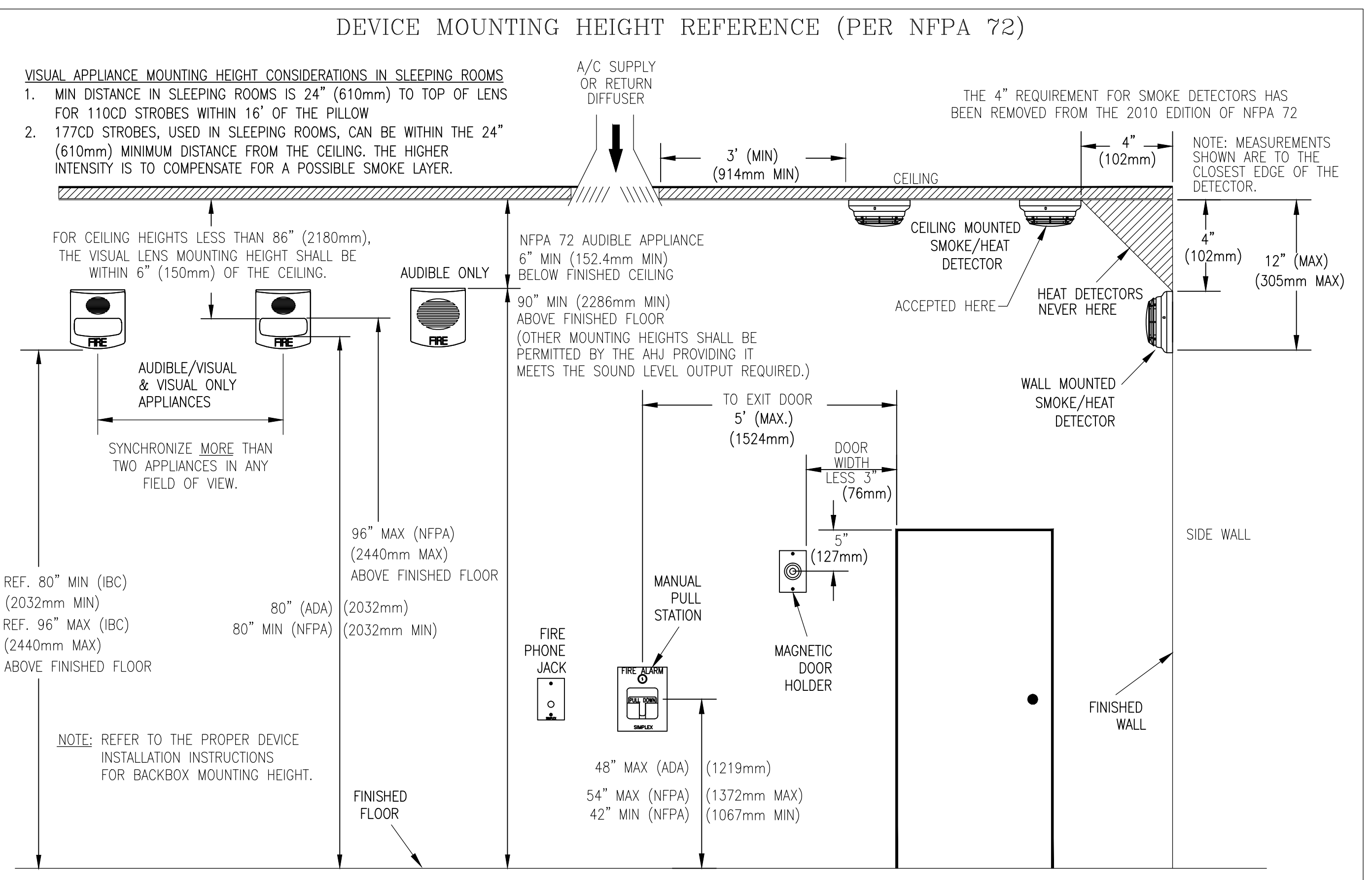

SimplexGrinnell Be Safe.
A Tyco International Company

20 THOMAS DRIVE
WESTBROOK, ME 04092
SALES: 207-842-6440
SERVICE: 207-842-6440
FAX: 207-842-6439

REVISION DESCRIPTION

DATE

NO.

FIRE ALARM & APARTMENT INTERCOM SYSTEM
DEVICE WIRING DETAIL
ELM TERRACE
68 HIGH STREET
PORTLAND, MAINE

DRAWN BY: LORION

CHECKED BY: KALAFARSKI

PROJECT NUMBER: 147420360

SHEET TITLE: FA/INTERCOM SYSTEMS DEVICE WIRING DETAIL

SHEET NUMBER: FA-701

DATE: 3/6/12

DATE: 3/13/12