

DISPLAY THIS CARD ON PRINCIPAL FRONTAGE OF WORK CITY OF PORTLAND

PERMIT TO WORK
MAR 22 2004
Permit Number: 04027
CITY OF PORTLAND

Please Read
Application And
Notes, If Any,
Attached

BUILDING DEPARTMENT PERMIT

This is to certify that Scott Merald E. &/self
has permission to Re-build existing front landing & steps in contact for
AT 22 Tate St 044 E015001

provided that the person or persons, firm or corporation accepting this permit shall comply with all of the provisions of the Statutes of Maine and of the ordinances of the City of Portland regulating the construction, maintenance and use of buildings and structures, and of the application on file in this department.

Apply to Public Works for street line and grade if nature of work requires such information.

Notification of inspection must be given and when permission is procured before this building or part thereof is laid or closed-in. HEADLINE NOTICE IS REQUIRED.

A certificate of occupancy must be procured by owner before this building or part thereof is occupied.

OTHER REQUIRED APPROVALS

Fire Dept. _____
Health Dept. _____
Appeal Board _____
Other _____
Department Name

Jeanne Bonke 3/22/04
Director - Building & Inspection Services

PENALTY FOR REMOVING THIS CARD

City of Portland, Maine - Building or Use Permit Application

389 Congress Street, 04101 Tel: (207) 874-8703, Fax: (207) 874-8716

PERMIT ISSUED

Permit No: 04-0270	Issue Date: MAR 22 2004	CBL: 044 E015001
-----------------------	----------------------------	---------------------

Location of Construction: 22 Tate St	Owner Name: Scott Mereald E &	Owner Address: 22 Tate St CITY OF PORTLAND	Phone: 345-3139
Business Name:	Contractor Name: self	Contractor Address: Portland	Phone:
Lessee/Buyer's Name	Phone:	Permit Type: Building Miscellaneous	Zone: R6

Past Use: Single Family	Proposed Use: Single Family w/front steps re-built	Permit Fee:	Cost of Work: \$500.00	CEO District: 2
----------------------------	---	-------------	---------------------------	--------------------

FIRE DEPT: <input type="checkbox"/> Approved <input type="checkbox"/> Denied	INSPECTION: Use Group: R3 Type: 5B accessory BOLA 1999 Signature: JMB 3/22/04
--	---

Proposed Project Description:
Re-build existing front landing & steps in exact footprint

Signature: _____ Date: _____

PEDESTRIAN ACTIVITIES DISTRICT (P.A.D.)

Action: Approved Approved w/Conditions Denied

Signature: _____ Date: _____

Permit Taken By: jmb	Date Applied For: 03/22/2004
-------------------------	---------------------------------

Zoning Approval

- This permit application does not preclude the Applicant(s) from meeting applicable State and Federal Rules.
- Building permits do not include plumbing, septic or electrical work.
- Building permits are void if work is not started within six (6) months of the date of issuance. False information may invalidate a building permit and stop all work..

Special Zone or Reviews	Zoning Appeal	Historic Preservation
<input type="checkbox"/> Shoreland <input type="checkbox"/> Wetland <input type="checkbox"/> Flood Zone <input type="checkbox"/> Subdivision <input type="checkbox"/> Site Plan Maj <input type="checkbox"/> Minor <input type="checkbox"/> MM <input type="checkbox"/>	<input type="checkbox"/> Variance <input type="checkbox"/> Miscellaneous <input type="checkbox"/> Conditional Use <input type="checkbox"/> Interpretation <input type="checkbox"/> Approved <input type="checkbox"/> Denied	<input checked="" type="checkbox"/> Not in District or Landmark <input type="checkbox"/> Does Not Require Review <input type="checkbox"/> Requires Review <input type="checkbox"/> Approved <input type="checkbox"/> Approved w/Conditions <input type="checkbox"/> Denied
Date: 3/22/04 JMB	Date:	Date: JMB

Approved See 14-385 allows reconstruction of non-constructing structure

CERTIFICATION

I hereby certify that I am the owner of record of the named property, or that the proposed work is authorized by the owner of record and that I have been authorized by the owner to make this application as his authorized agent and I agree to conform to all applicable laws of this jurisdiction. In addition, if a permit for work described in the application is issued, I certify that the code official's authorized representative shall have the authority to enter all areas covered by such permit at any reasonable hour to enforce the provision of the code(s) applicable to such permit.

SIGNATURE OF APPLICANT	ADDRESS	DATE	PHONE
RESPONSIBLE PERSON IN CHARGE OF WORK, TITLE		DATE	PHONE

3/26/01 Footings okay - net ledge at 30", using 8" sonnet
tubes, will call when finished

Location of Construction: 22 Tate St	Owner Name: Scott Merealda E &	Owner Address: 22 Tate St	Phone: 345-3139
Business Name:	Contractor Name: self	Contractor Address: Portland	Phone
Lessee/Buyer's Name	Phone:	Permit Type: Building Miscellaneous	Zone:

Dept: Zoning	Status: Approved	Reviewer: Jeanine Bourke	Approval Date: 03/22/2004
Note:			Ok to Issue: <input checked="" type="checkbox"/>
1) Sec. 14-385 allows the reconstruction of a non-conforming structure within the same footprint			
Dept: Building	Status: Approved	Reviewer: Jeanine Bourke	Approval Date: 03/22/2004
Note:			Ok to Issue: <input checked="" type="checkbox"/>

CERTIFICATION

I hereby certify that I am the owner of record of the named property, or that the proposed work is authorized by the owner of record and that I have been authorized by the owner to make this application as his authorized agent and I agree to conform to all applicable laws of this jurisdiction. In addition, if a permit for work described in the application is issued, I certify that the code official's authorized representative shall have the authority to enter all areas covered by such permit at any reasonable hour to enforce the provision of the code(s) applicable to such permit.

SIGNATURE OF APPLICAN	ADDRESS	DATE	PHO
-----------------------	---------	------	-----

RESPONSIBLE PERSON IN CHARGE OF WORK, TIT	DATE	PHO
---	------	-----

All Purpose Building Permit Application

If you or the property owner owes real estate or personal property taxes or user charges on any property within the City, payment arrangements must be made before permits of any kind are accepted.

Location/Address of Construction: <u>22 Tate</u>		
Total Square Footage of Proposed Structure <u>45 SF</u>	Square Footage of Lot <u>1972 SF</u>	
Tax Assessor's Chart, Block & Lot Chart# <u>44</u> Block# <u>E</u> Lot# <u>15</u>	Owner: <u>Mereald Scott</u> <u>22 Tate St.</u>	Telephone: <u>201-345-3139</u>
Lessee/Buyer's Name (if Applicable)	Applicant name, address & telephone: <u>same</u>	Cost Of Work: \$ <u>500.00</u> Fee: \$ <u>30.00</u>
Current use: <u>SF Home</u>		
If the location is currently vacant, what was prior use: _____		
Approximately how long has it been vacant: _____		
Proposed use: <u>SF Home</u>		
Project description: <u>rebuild existing steps 3x8 platform & steps</u>		
Contractor's name, address & telephone: <u>self</u>		
Who should we contact when the permit is ready: _____		
Mailing address: _____		
We will contact you by phone when the permit is ready. You must come in and pick up the permit and review the requirements before starting any work, with a Plan Reviewer. A stop work order will be issued and a \$100.00 fee if any work starts before the permit is picked up. PHONE: _____		

IF THE REQUIRED INFORMATION IS NOT INCLUDED IN THE SUBMISSIONS THE PERMIT WILL BE AUTOMATICALLY DENIED AT THE DISCRETION OF THE BUILDING/PLANNING DEPARTMENT, WE MAY REQUIRE ADDITIONAL INFORMATION IN ORDER TO APPROVE THIS PERMIT.

I hereby certify that I am the Owner of record of the named property, or that the owner of record authorizes the proposed work and that I have been authorized by the owner to make this application as his/her authorized agent. I agree to conform to all applicable laws of this jurisdiction. In addition, if a permit for work described in this application is issued, I certify that the Code Official's authorized representative shall have the authority to enter all areas covered by this permit at any reasonable hour to enforce the provisions of the codes applicable to this permit.

Signature of applicant: _____	Date: _____
-------------------------------	-------------

**This is NOT a permit, you may not commence ANY work until the permit is issued.
If you are in a Historic District you may be subject to additional permitting and fees with the Planning Department on the 4th floor of City Hall**

BUILDING PERMIT INSPECTION PROCEDURES

Please call 874-8703 or 874-8693 to schedule your inspections as agreed upon

Permits expire in 6 months, if the project is not started or ceases for 6 months.

The Owner or their designee is required to notify the inspections office for the following inspections and provide adequate notice. Notice must be called in 48-72 hours in advance in order to schedule an inspection:

By initializing at each inspection time, you are agreeing that you understand the inspection procedure and additional fees from a "Stop Work Order" and "Stop Work Order Release" will be incurred if the procedure is not followed as stated below.

JB **Pre-construction Meeting:** Must be scheduled with your inspection team upon receipt of this permit. ~~Jay Reynolds, Development Review Coordinator at 874-8693~~ must also be contacted at this time, before any site work begins on any project other than single family additions or alterations.

Footing/Building Location Inspection: Prior to pouring concrete

3/23 in the afternoon

NA **Re-Bar Schedule Inspection:** Prior to pouring concrete

NA **Foundation Inspection:** Prior to placing ANY backfill

NA **Framing/Rough Plumbing/Electrical:** Prior to any insulating or drywalling

Final/Certificate of Occupancy: Prior to any occupancy of the structure or use. NOTE: There is a \$75.00 fee per inspection at this point.

Certificate of Occupancy is not required for certain projects. Your inspector can advise you if your project requires a Certificate of Occupancy. All projects DO require a final inspection

If any of the inspections do not occur, the project cannot go on to the next phase, REGARDLESS OF THE NOTICE OR CIRCUMSTANCES.

NA **CERIFICATE OF OCCUPANICES MUST BE ISSUED AND PAID FOR, BEFORE THE SPACE MAY BE OCCUPIED**

Manuel S. [Signature]
Signature of Applicant/Designee

3-22-04
Date

[Signature]
Signature of Inspections Official

3/22/04
Date

CBL: 44-E-15 Building Permit #: 04-0270

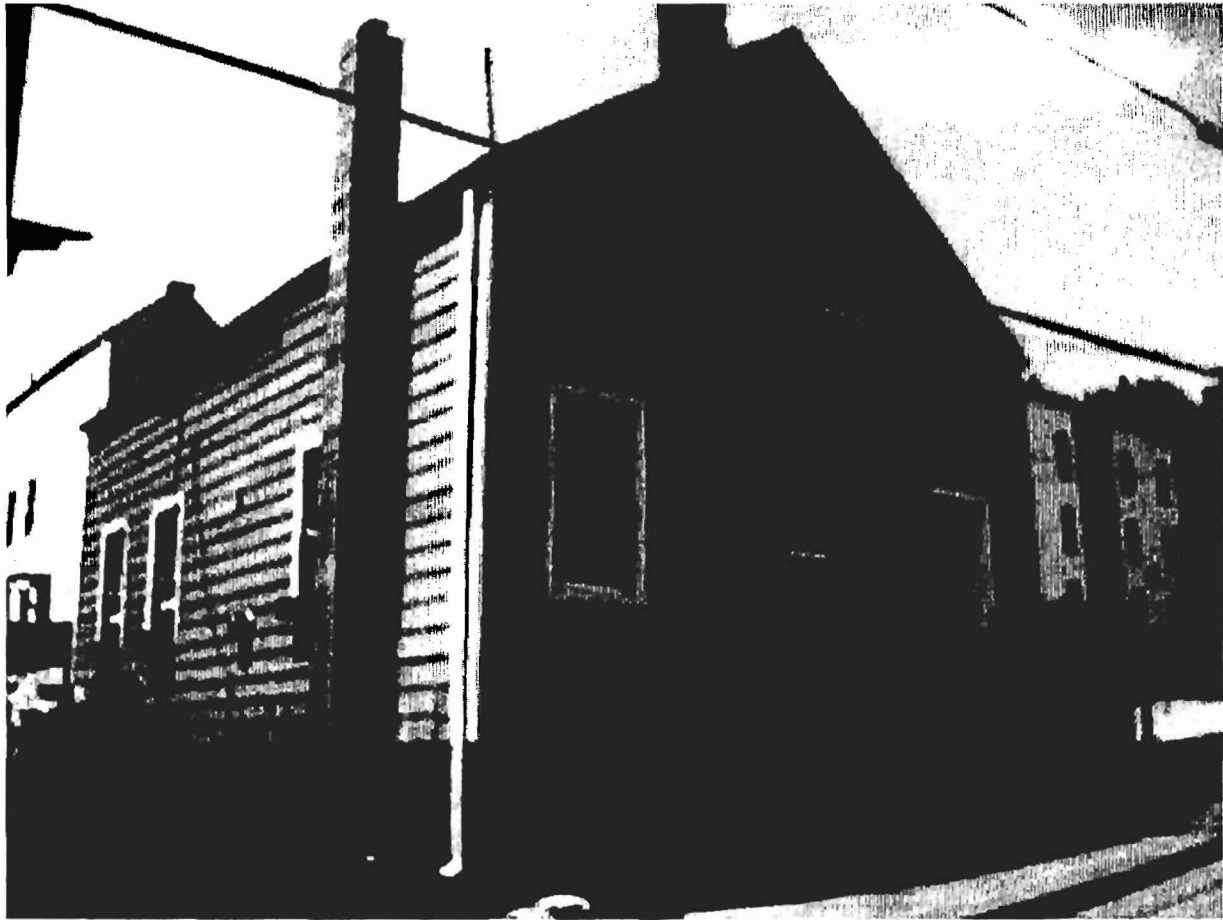

This page contains a detailed description of the Parcel ID you selected. Press the **New Search** button at the bottom of the screen to submit a new query.

Current Owner Information

Card Number 1 of 1
 Parcel ID 044 E015001
 Location 22 TATE ST
 Land Use SINGLE FAMILY
 Owner Address SCOTT MEREALD E & SANDRA L JTS
 22 TATE ST
 PORTLAND ME 04102

*9 Am 3/22
 Merald*

*04-0270
 R6*

Book/Page
 Legal → 44-E-15
 TATE ST 22
 → 1972 SF

*55 Directory
 SF*

Valuation Information

Land Building Total
 \$30,030 \$17,960 \$47,990

Property Information

Year Built 1840	Style Old Style	Story Height 1.5	Sq. Ft. 1208	Total Acres 0.045	
Bedrooms 3	Full Baths 1	Half Baths	Total Rooms 5	Attic None	Basement Full

Outbuildings

Type	Quantity	Year Built	Size	Grade	Condition
-------------	-----------------	-------------------	-------------	--------------	------------------

Sales Information

Date	Type	Price	Book/Page
-------------	-------------	--------------	------------------

Picture and Sketch

[Picture](#) [Sketch](#)

[Click here to view Tax Roll Information.](#)

Any information concerning tax payments should be directed to the Treasury office at 874-8490 or e-mailed.

New Search!

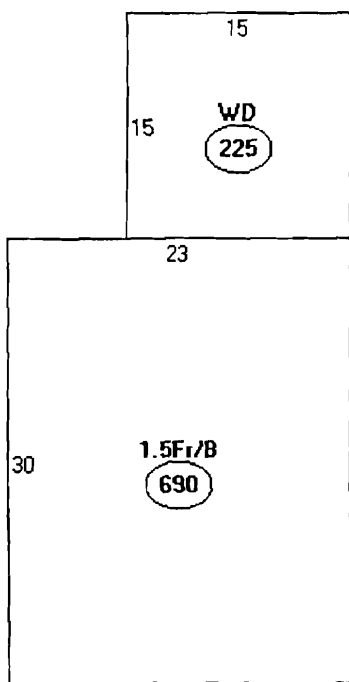

Descriptor/Area

A: 1.5Fr/B
690 sqft

B: WD
225 sqft



DECK FRAMING

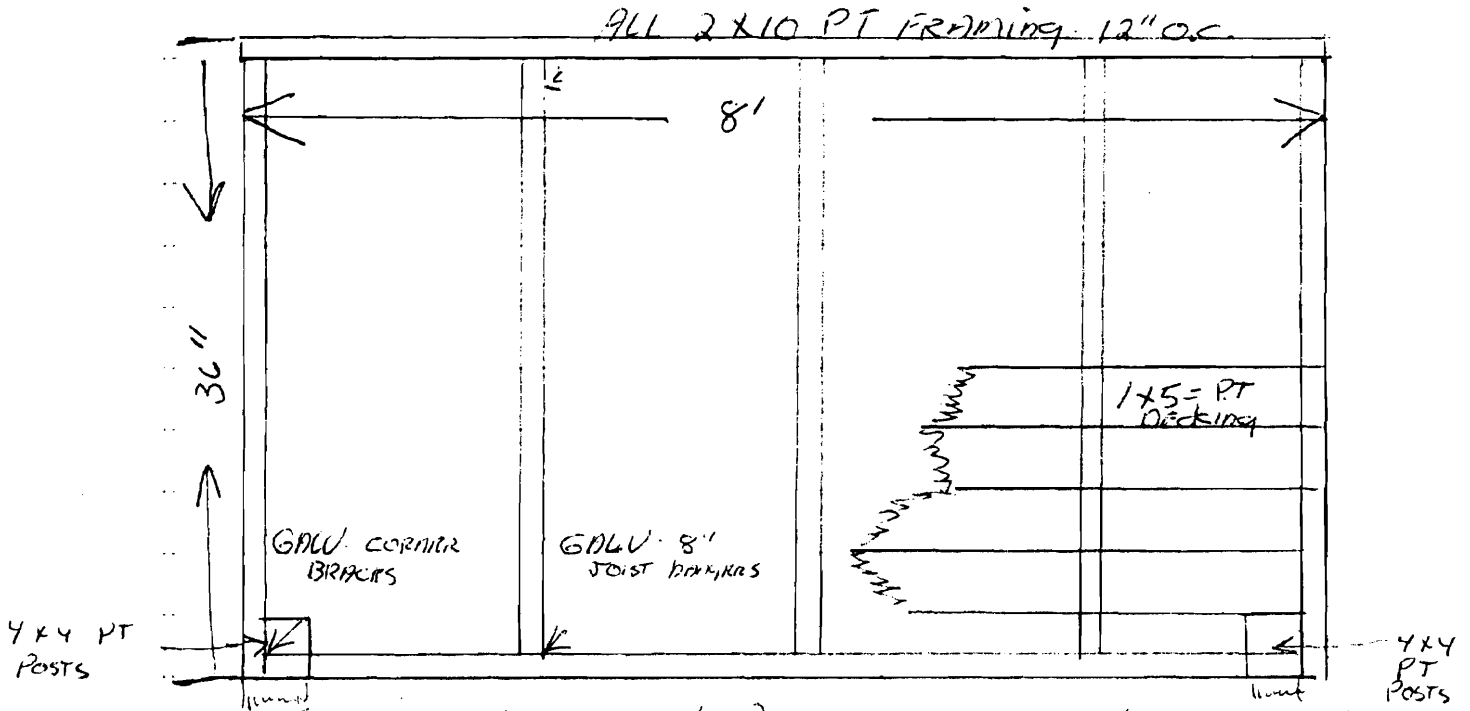

FRAMING PLATE ATTACHED TO SILL WITH 6" GALV LAGS BOLTS

ALL FRAMING ATTACHED WITH GALV JOIST HANGERS AND CORNER BRACKETS

4x4 POSTS ARE TO BE LIFTED TO CORNERS. ~~NOT~~

BOLTED TO DECK FRAMING WITH 5/2 GALV 3/8 NUTS BOLTS

MATERIALS = 2 = 2"x10"x12' PT

4 = 8" GALV CORNER BRACKETS

8 = 8" JOIST HANGERS

8 = 12' 5x6 = Decking PT

3 = 2"x12" STRINGERS PT

2 = 4'x10" SONA TUBS

4 = BAGS CONCRETE MIX

4 = 4x4x8' PT POSTS

4 = BUNDLES 32" BALLASTS

16' BANISTER HAND RAIL

GALV DECK SCREWS

GALV NUTS BOLTS

GALV 6" LAGS

GALV POST MOUNTS

PLATFORM -

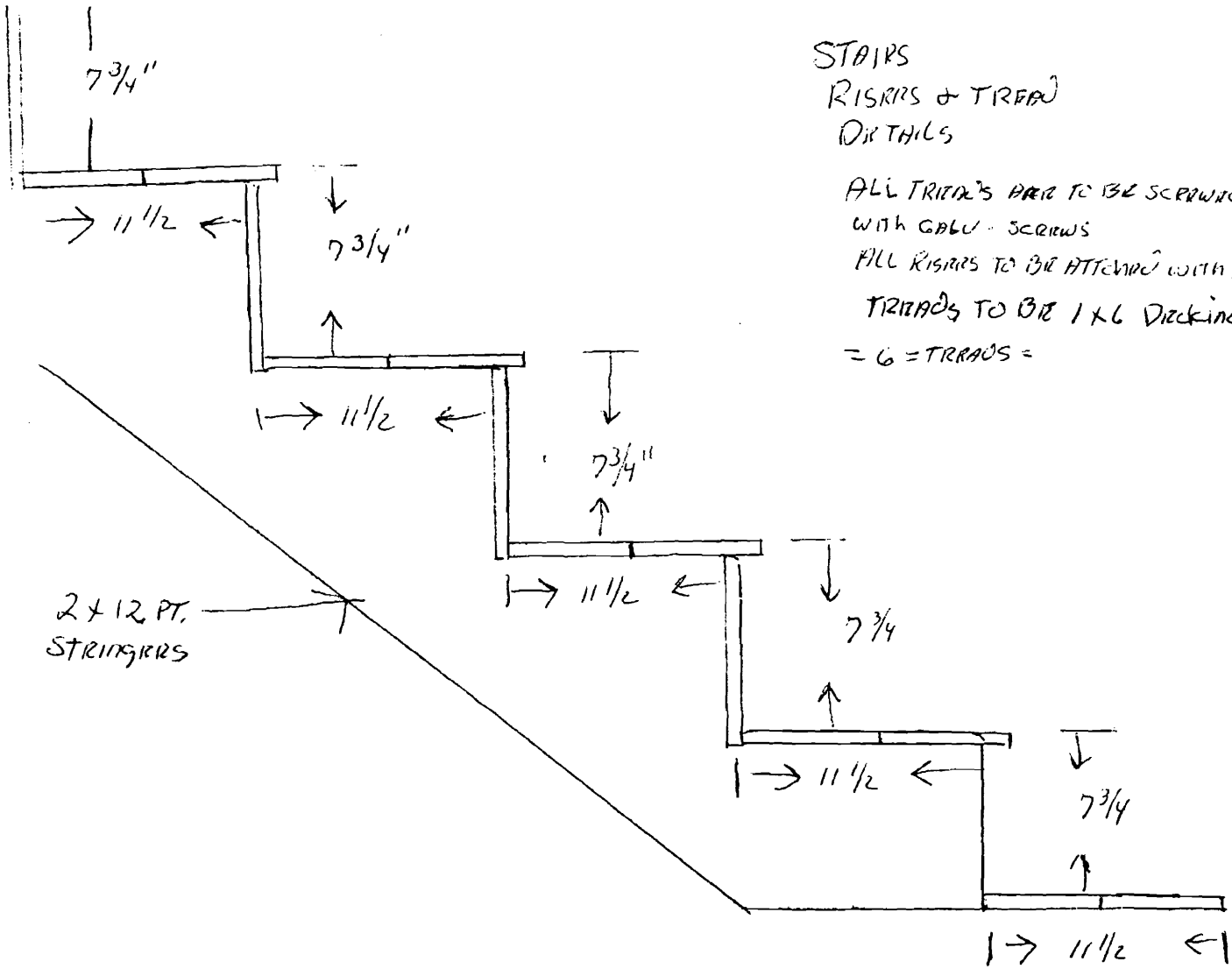

STAIRS
RISERS & TREADS
DETAILS

ALL TREADS ARE TO BE SCREWED.

WITH GALV. SCREWS

ALL RISERS TO BE ATTACHED WITH SCREWS

TREADS TO BE 1 X 6 Decking

= 6 TREADS =

1 1/2' DIAMETER 1 1/2" APART.

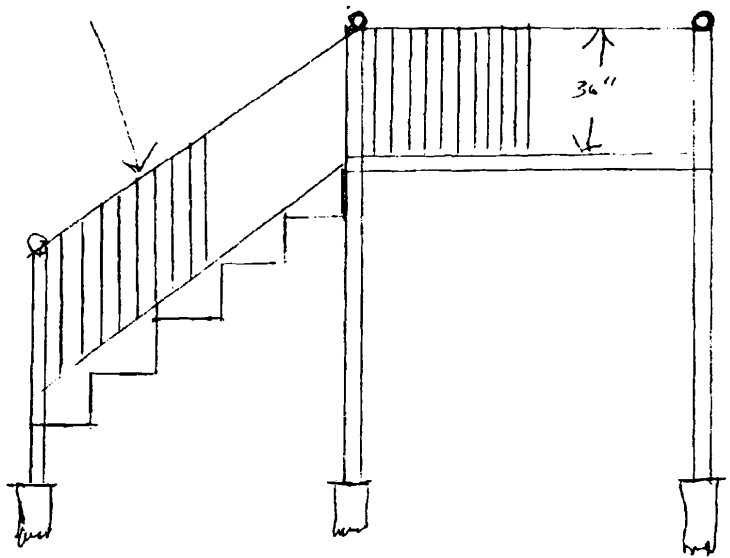

New 10" sona tubes 4' depth

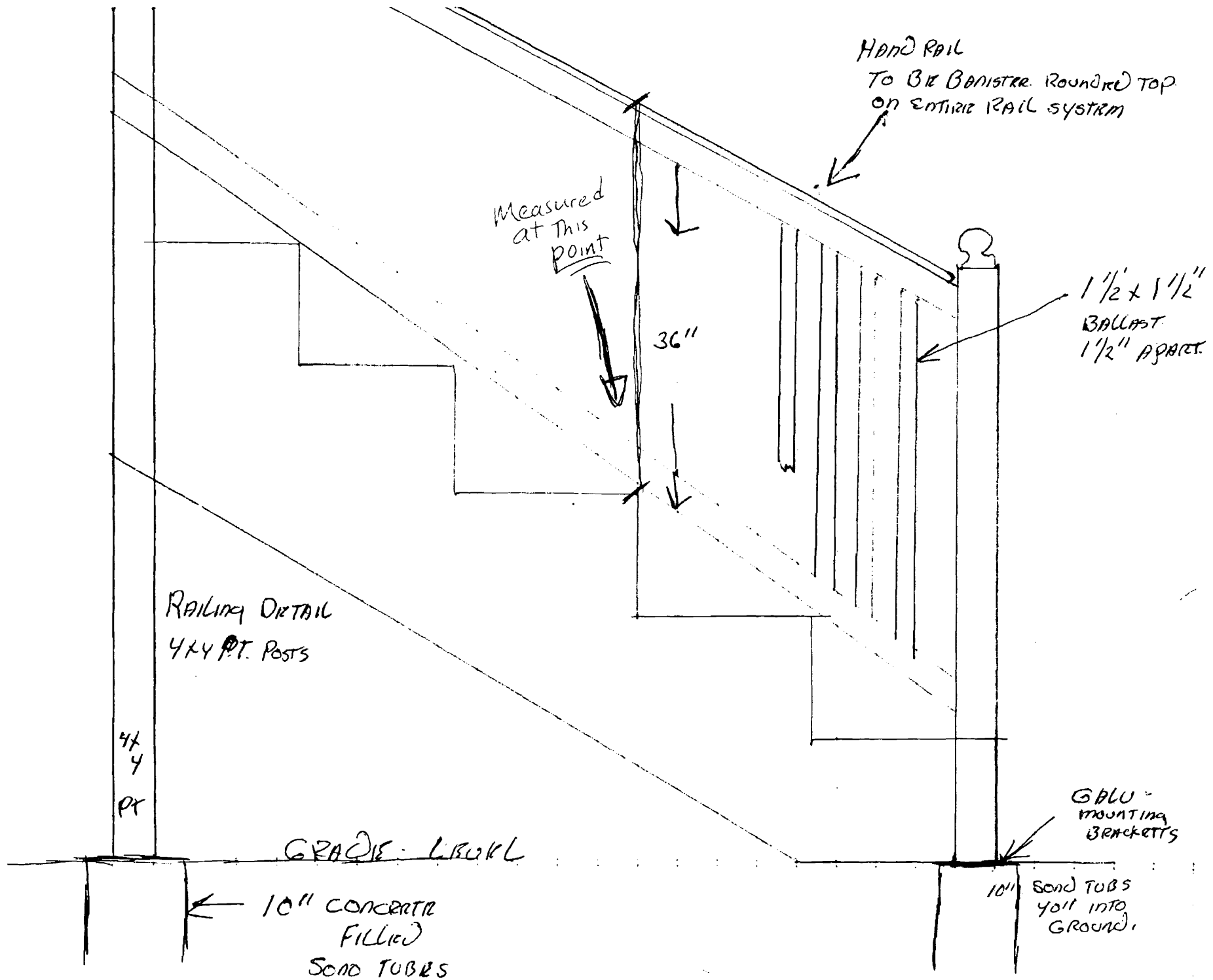



CITY OF PORTLAND, MAINE

Department of Building Inspections

20

Received from _____

Location of Work _____

Cost of Construction \$ _____

Permit Fee \$ _____

Building (I1) ___ Plumbing (I5) ___ Electrical (I2) ___ Site Plan (U2) ___

Other _____

CBL: _____

Check #: _____

Total Collected \$ _____

THIS IS NOT A PERMIT

No work is to be started until PERMIT CARD is actually posted upon the premises. Acceptance of fee is no guarantee that permit will be granted. PRESERVE THIS RECEIPT. In case permit cannot be granted the amount of the fee will be refunded upon return of the receipt less \$10.00 or 10% whichever is greater.

WHITE - Applicant's Copy
YELLOW - Office Copy
PINK - Permit Copy