

City of Portland, Maine – Building or Use Permit Application 389 Congress Street, 04101, Tel: (207) 874-8703, FAX: 874-8716

Location of Construction: 30-32 State Street		Owner: *** Jim Price		Phone: ***741-1623		Permit No: 010027	
Owner Address:		Lessee/Buyer's Name:		Phone:		BusinessName:	
Contractor Name: Jim Price		Address: 154 Harris Road, Cumberland		Phone: ME 04021		Permit Issued: JAN 0 1	
Past Use: Multi Family Multi Family <i>Legal 8 Dwelling units</i>		Proposed Use: Multi Family <i>no change of use is permitted under this permit</i>		COST OF WORK: \$ 2,000.00		PERMIT FEE: \$ 36.00	
Proposed Project Description: Repair Replace front steps		Signature:		FIRE DEPT. <input type="checkbox"/> Approved <input type="checkbox"/> Denied		INSPECTION: Use Group <i>A-2</i> Type <i>5B</i> <i>BOCA 94</i>	
				PEDESTRIAN ACTIVITIES DISTRICT (P.A.D.) Action: Approved <input type="checkbox"/> Approved with Conditions: <input type="checkbox"/> Denied <input type="checkbox"/>		Signature: <i>[Signature]</i> Date:	
Permit Taken By: Gayle		Date Applied For: November 29, 2000 GG		Zoning: CBL: 044-C-008		Zoning Approval: <i>8 units ok per microfiche</i>	

1. This permit application does not preclude the Applicant(s) from meeting applicable State and Federal rules.
2. Building permits do not include plumbing, septic or electrical work.
3. Building permits are void if work is not started within six (6) months of the date of issuance. False information may invalidate a building permit and stop all work..

PERMIT ISSUED WITH REQUIREMENTS

CERTIFICATION

I hereby certify that I am the owner of record of the named property, or that the proposed work is authorized by the owner of record and that I have been authorized by the owner to make this application as his authorized agent and I agree to conform to all applicable laws of this jurisdiction. In addition, if a permit for work described in the application is issued, I certify that the code official's authorized representative shall have the authority to enter all areas covered by such permit at any reasonable hour to enforce the provisions of the code(s) applicable to such permit

November 29, 2000

SIGNATURE OF APPLICANT _____ ADDRESS: _____ DATE: _____ PHONE: _____

RESPONSIBLE PERSON IN CHARGE OF WORK, TITLE _____ PHONE: _____

Zoning Appeal

Variance
 Miscellaneous
 Conditional Use
 Interpretation
 Approved
 Denied

Historic Preservation

Not in District or Landmark
 Does Not Require Review
 Requires Review

Action:

Approved
 Approved with Conditions
 Denied

Date: *TODA 11/29*
WBL 12-20-00

PERMIT ISSUED WITH REQUIREMENTS

CEO DISTRICT 3

THIS IS NOT A PERMIT/CONSTRUCTION CANNOT COMMENCE UNTIL THE PERMIT IS ISSUED

Minor/Minor Site Review for New Detached Single Family Dwelling, Additions/Alterations/Accessory Structures, Multi-Family, Commercial Interior Rehab (other than additions), Change of Use

In the interest of processing your application in the quickest possible manner, please complete the information below for a Building or Use Permit.

NOTEIf you or the property owner owes real estate or personal property taxes or user charges on any property within the City, payment arrangements must be made before permits of any kind are accepted.**

Location/Address of Construction: <u>30-32 STATE ST</u>

Total Square Footage of Proposed Structure <u>80 FT² ±</u>	Square Footage of Lot <u>8476</u>
---	-----------------------------------

Tax Assessor's Chart, Block & Lot Number Chart# <u>044</u> Block# <u>C</u> Lot# <u>008</u>	Owner: <u>Jim Rice</u>	Telephone#: <u>741-1623</u>

Lessee/Buyer's Name (If Applicable)	Owner's/Purchaser/Lessee Address:	Cost Of Work: <u>\$ 2000</u> Fee: <u>\$ 36.00</u>
-------------------------------------	-----------------------------------	--

Current use: <u>FRONT STEPS</u>	Proposed use: <u>SAME</u>
Project description: <u>REPLACE FRONT STEPS</u>	

Contractor's Name, Address & Telephone <u>JIM PRICE, 154 HARRIS RD, CUMBERLAND ME 04021</u>	Rec'd By: <u>Gay</u>
--	----------------------

Separate permits are required for Internal & External Plumbing, HVAC and Electrical installation.

- All construction must be conducted in compliance with the 1999 B.O.C.A. Building Code as amended by Section 6-Art II.
- All plumbing must be conducted in compliance with the State of Maine Plumbing Code.
- All Electrical Installation must comply with the 1999 National Electrical Code as amended by Section 6-Art III.
- HVAC(Heating, Ventilation and Air Conditioning) installation must comply with the 1993 B.O.C.A. Mechanical Code.

YOU MUST INCLUDE THE FOLLOWING WITH YOUR APPLICATION:

- A Copy of Your Deed or Purchase and Sale Agreement if purchased in the last 365 days
- A Plot Plan (Sample Attached)

A "minor/minor" site plan review is required for New Single Family Homes Only (does not include additions, alterations or accessory structures) prior to permit issuance. The Site plan must be prepared and sealed by a registered land surveyor. FOUR COPIES ARE REQUIRED FOR NEW SINGLE FAMILY HOMES

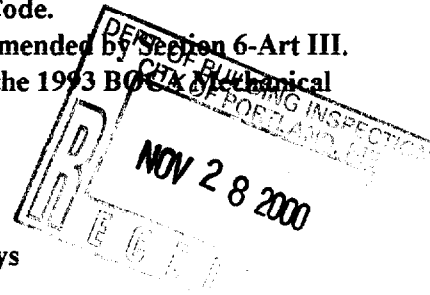

THIS IS NOT A PERMIT/CONSTRUCTION CANNOT COMMENCE UNTIL THE PERMIT IS ISSUED

A complete plot plan (Site Plan) includes:

- The shape and dimension of the lot, all existing buildings (if any), the proposed structure and the distance from the actual property lines. Structures include decks porches, a bow windows cantilever sections and roof overhangs, as well as, sheds, pools, garages and any other accessory structures.
- Scale and North arrow; Zoning District & Setbacks
- First Floor sill elevation (based on mean sea level datum);
- Location and dimensions of parking areas and driveways;
- Location and size of both existing utilities in the street and the proposed utilities serving the building;
- Location of areas on the site that will be used to dispose of surface water.
- Existing and proposed grade contours

Building Plans are required for all construction, including interior rehab (Sample Attached)

A complete set of construction drawings showing all of the following elements of construction:

- Cross Sections w/Framing details (including porches, decks w/ railings, and accessory structures)
- Floor Plans & Elevations
- Window and door schedules
- Foundation plans with required drainage and damp proofing
- Electrical and plumbing layout. Mechanical drawings for any specialized equipment such as furnaces, chimneys, gas equipment, HVAC equipment (air handling) or other types of work that may require special review must be included.

Certification

I hereby certify that I am the Owner of record of the named property, or that the proposed work is authorized by the owner of record and that I have been authorized by the owner to make this application as his/her authorized agent. I agree to conform to all applicable laws of this jurisdiction. In addition, if a permit for work described in this application is issued, I certify that the Code Official's authorized representative shall have the authority to enter all areas covered by this permit at any reasonable hour to enforce the provisions of the codes applicable to this permit.

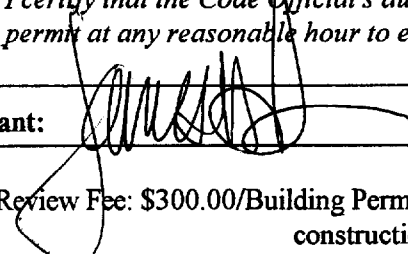
Signature of applicant: 	Date: 11 28 00
--	---------------------------

Minor/Minor Site Review Fee: \$300.00/Building Permit Fee: \$30.00 for the 1st \$1000.cost plus \$6.00 per \$1,000.00 construction cost thereafter.

AUTOCAD OR ADOBE FORMAT REQUIRED FOR ALL COMMERICAL PROJECTS

BUILDING PERMIT REPORT

DATE: 29 November 2k ADDRESS: 30-32 STATE ST. CBL: 044-C-008

REASON FOR PERMIT: Replace Front Step

BUILDING OWNER: Jim Price

PERMIT APPLICANT: CONTRACTOR Jim Price

USE GROUP: R-2 CONSTRUCTION TYPE: 53 CONSTRUCTION COST: 2000 PERMIT FEES: 200

The City's Adopted Building Code (The BOCA National Building Code/1999 with City Amendments)
The City's Adopted Mechanical Code (The BOCA National Mechanical Code/1993)

CONDITION(S) OF APPROVAL

This permit is being issued with the understanding that the following conditions shall be met: #1, #2, #11, #13, #31

- *1. This permit does not excuse the applicant from meeting applicable State and Federal rules and laws.
*2. Before concrete for foundation is placed, approvals from the Development Review Coordinator and Inspection Services must be obtained.
3. Foundation drain shall be placed around the perimeter of a foundation that consists of gravel or crushed stone containing not more than 10 percent material that passes through a No. 4 sieve.
4. Foundations anchors shall be a minimum of 1/2" in diameter, 7" into the foundation wall, minimum of 12" from corners of foundation and a maximum 6' O.C. between bolts.
5. Waterproofing and dampproofing shall be done in accordance with Section 1813.0 of the building code.
6. Precaution must be taken to protect concrete from freezing. Section 1908.0
7. It is strongly recommended that a registered land surveyor check all foundation forms before concrete is placed.
8. Private garages located beneath habitable rooms in occupancies in Use Group R-1, R-2, R-3 or I-1 shall be separated from adjacent interior spaces by fire partitions and floor/ceiling assembly which are constructed with not less than 1-hour fire resisting rating.
9. All chimneys and vents shall be installed and maintained as per Chapter 12 of the City's Mechanical Code.
10. Sound transmission control in residential building shall be done in accordance with Chapter 12, Section 1214.0 of the City's Building Code.
*11. Guardrails & Handrails: A guardrail system is a system of building components located near the open sides of elevated walking surfaces for the purpose of minimizing the possibility of an accidental fall from the walking surface to the lower level.
12. Headroom in habitable space is a minimum of 7'6". (Section 1204.0)
*13. Stair construction in Use Group R-3 & R-4 is a minimum of 10" tread and 7 1/2" maximum rise.
14. The minimum headroom in all parts of a stairway shall not be less than 80 inches. (6'8") 1014.4
15. Every sleeping room below the fourth story in buildings of Use Groups R and I-1 shall have at least one operable window or exterior door approved for emergency egress or rescue.
16. Each apartment shall have access to two (2) separate, remote and approved means of egress.
17. All vertical openings shall be enclosed with construction having a fire rating of at least one (1) hour, including fire doors with self closure's.
18. The boiler shall be protected by enclosing with (1) hour fire rated construction including fire doors and ceiling, or by providing automatic extinguishment.

19. All single and multiple station smoke detectors shall be of an approved type and shall be installed in accordance with the provisions of the City's Building Code Chapter 9, Section 920.3.2 (BOCA National Building Code/1999), and NFPA 101 Chapter 18 & 19. (Smoke detectors shall be installed and maintained at the following locations):
 - In the immediate vicinity of bedrooms
 - In all bedrooms
 - In each story within a dwelling unit, including basements
20. A portable fire extinguisher shall be located as per NFPA #10. They shall bear the label of an approved agency and be of an approved type. (Section 921.0)
21. The Fire Alarm System shall be installed and maintained to NFPA #72 Standard.
22. The Sprinkler System shall be installed and maintained to NFPA #13 Standard.
23. All exit signs, lights and means of egress lighting shall be done in accordance with Chapter 10 Section & Subsections 1023.0 & 1024.0 of the City's Building Code. (The BOCA National Building Code/1999)
24. Section 25 - 135 of the Municipal Code for the City of Portland states, "No person or utility shall be granted a permit to excavate or open any street or sidewalk from the time of November 15 of each year to April 15 of the following year".
25. The builder of a facility to which Section 4594-C of the Maine State Human Rights Act Title 5 MRSA refers, shall obtain a certification from a design professional that the plans commencing construction of the facility, the builder shall submit the certification the Division of Inspection Services.
26. Ventilation and access shall meet the requirements of Chapter 12 Sections 1210.0 and 1211.0 of the City's Building Code. (Crawl spaces & attics).
27. All electrical, plumbing and HVAC permits must be obtained by Master Licensed holders of their trade. No closing in of walls until all electrical (min. 72 hours notice) and plumbing inspections have been done.
28. All requirements must be met before a final Certificate of Occupancy is issued.
29. All building elements shall meet the fastening schedule as per Table 2305.2 of the City's Building Code (The BOCA National Building Code/1996).
30. Ventilation of spaces within a building shall be done in accordance with the City's Mechanical code (The BOCA National Mechanical Code/1993). (Chapter M-16)
31. Please read and implement the attached Land Use Zoning report requirements. *Not to increase the existing front steps during maintenance reconstruction*
32. Boring, cutting and notching shall be done in accordance with Sections 2305.3, 2305.3.1, 2305.4.4 and 2305.5.1 of the City's Building Code.
33. Bridging shall comply with Section 2305.16.
34. Glass and glazing shall meet the requirements of Chapter 24 of the building code. (Safety Glazing Section 2406.0)
35. All signage, shall be done in accordance with Section 3102.0 signs of the City's Building Code, (The BOCA National Building Code/1999).
36. All flashing shall comply with Section 1406.3.10.

[Signature]
 P. S. Hoffses, Building Inspector
 Sgt. Lt. McDougall, PFD
 Marge Schmuckal, Zoning Administrator

PSH 10/1/00

**This permit is herewith issued, on the basis of plans submitted and conditions placed on these plans, any deviations shall require a separate approval.

***THIS PERMIT HAS BEEN ISSUED WITH THE UNDERSTANDING THAT ALL THE CONDITIONS OF THE APPROVAL SHALL BE COMPLETED. THEREFORE, BEFORE THE WORK IS COMPLETED A REVISED PLAN OR STATEMENT FROM THE PERMIT HOLDER SHALL BE SUBMITTED TO THIS OFFICE SHOWING OR EXPLAINING THAT THE CONDITIONS HAVE BEEN MET. IF THIS REQUIREMENT IS NOT RECEIVED YOUR CERTIFICATE OF OCCUPANCY SHALL BE WITHHELD.

****ALL PLANS THAT REQUIRE A PROFESSIONAL DESIGNER'S SEAL, (AS PER SECTION 114.0 OF THE BUILDING CODE) SHALL ALSO BE PRESENTED TO THIS DIVISION ON AUTO CAD LT. 2000, DXF FORMAT OR EQUIVALENT.

*****CERTIFICATE OF OCCUPANCY FEE \$50.00

Application for Exemption From Building Code Railing Height Requirements

* Exemptions apply only for designated landmark structures and structures located in historic districts, per BOCA regulations. Requests need approval from both the Historic Preservation and Building Inspections divisions of the Planning Dept.

James H. Price
Applicant

154 Harris Road.
Applicant's Mailing Address

829-4466 (H) 741-1623 (Pager)
Contact Person/Phone Number

12-4-00
Application Date
30-32 State St.
Address of Subject Property

Description of Project (please attach photograph of existing conditions and/or plan of project):

Replace steps & handrails

Please provide the following information:

1. Current Use of Property (If multi-family residence, please indicate # of units):
8 unit multi-family
2. Proposed Use, if applicable: same
3. The distance from the porch deck to the ground: 54" to 60"
4. The number of existing stair risers: 6 on #32 side 7 on #30 side
5. The current railing height and/or documented original railing height: Porch 42" Handrails 36"
6. The railing height requested: 42" for porch; 36" for steps

Planning Office Use Only:

Historic Preservation Committee/Staff Recommendation: Recommends reduction to 36" at stairs.
William F. Neelmann

Inspections Staff Recommendation: This building classified as an historic structure per our Historic Preservation Staff. Therefore under Section 3406.0 of The City's building code, states - The provisions of this code relating to the construction, repair, alterations, addition, restoration and moving of structures shall not be mandatory for existing buildings.

Exemption Granted Conditional Exemption Exemption Denied

Signature [Signature] Date: 12/20/00

1 NEWEL POST 30-32 STATE ST.

MATERIAL: HEMLOCK POST
PINE CLAD.
PINE TOP

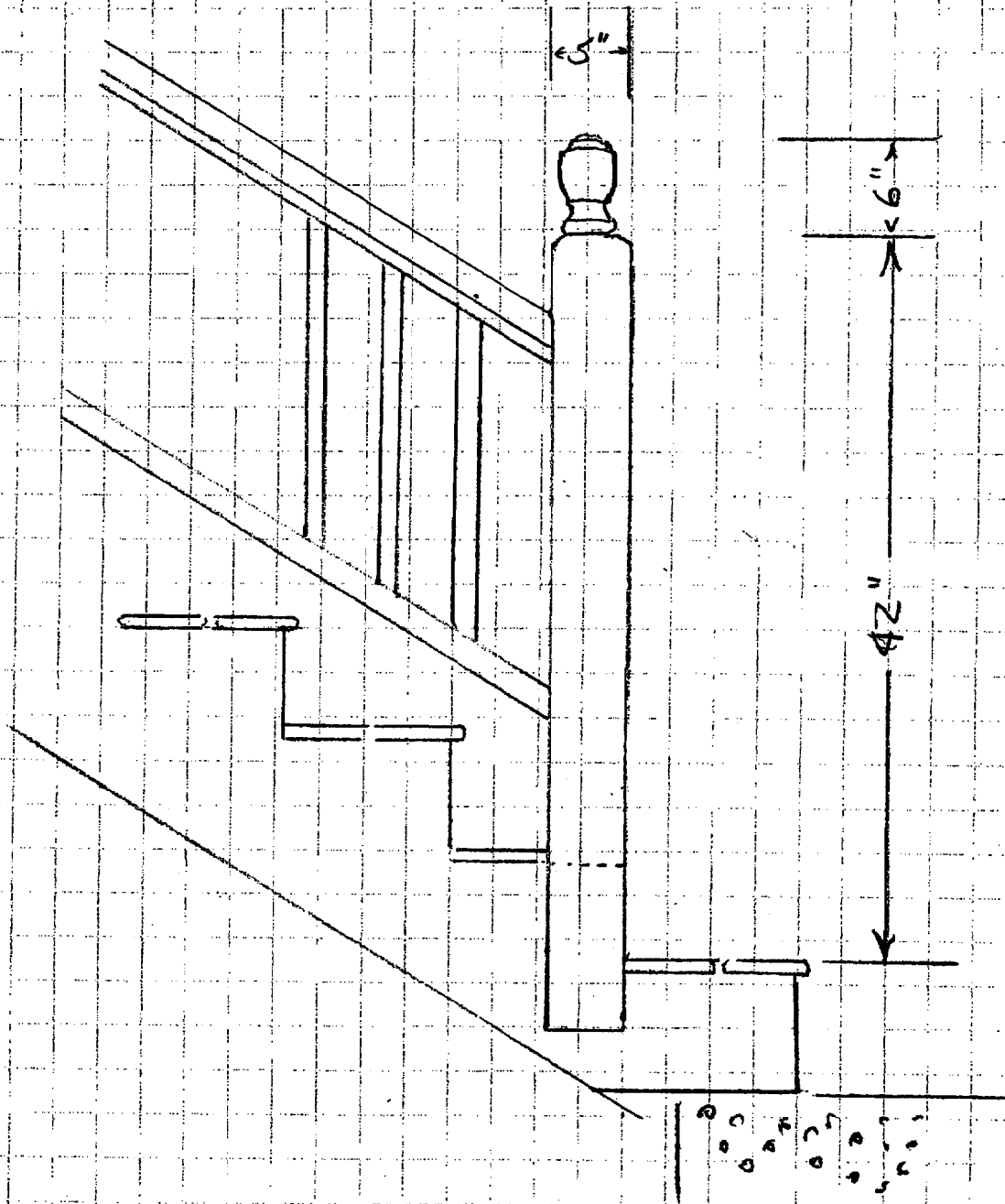
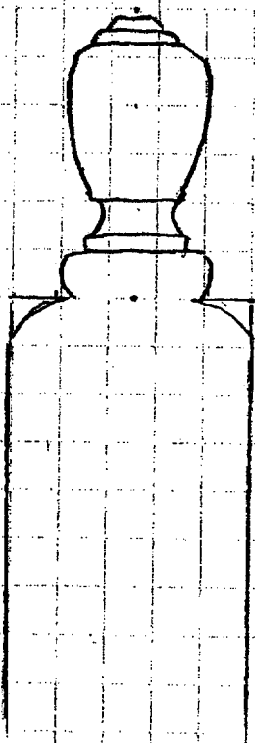
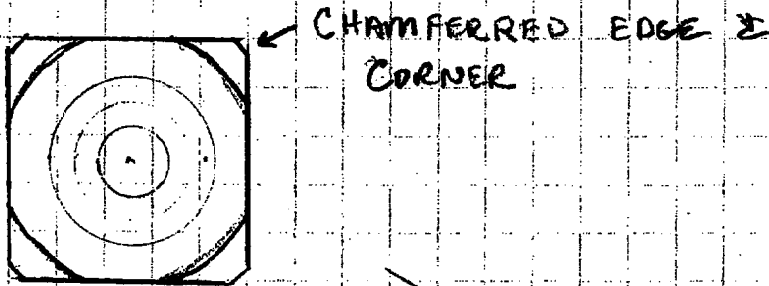

SETBACK 30-32 STATE ST
1" = 20'

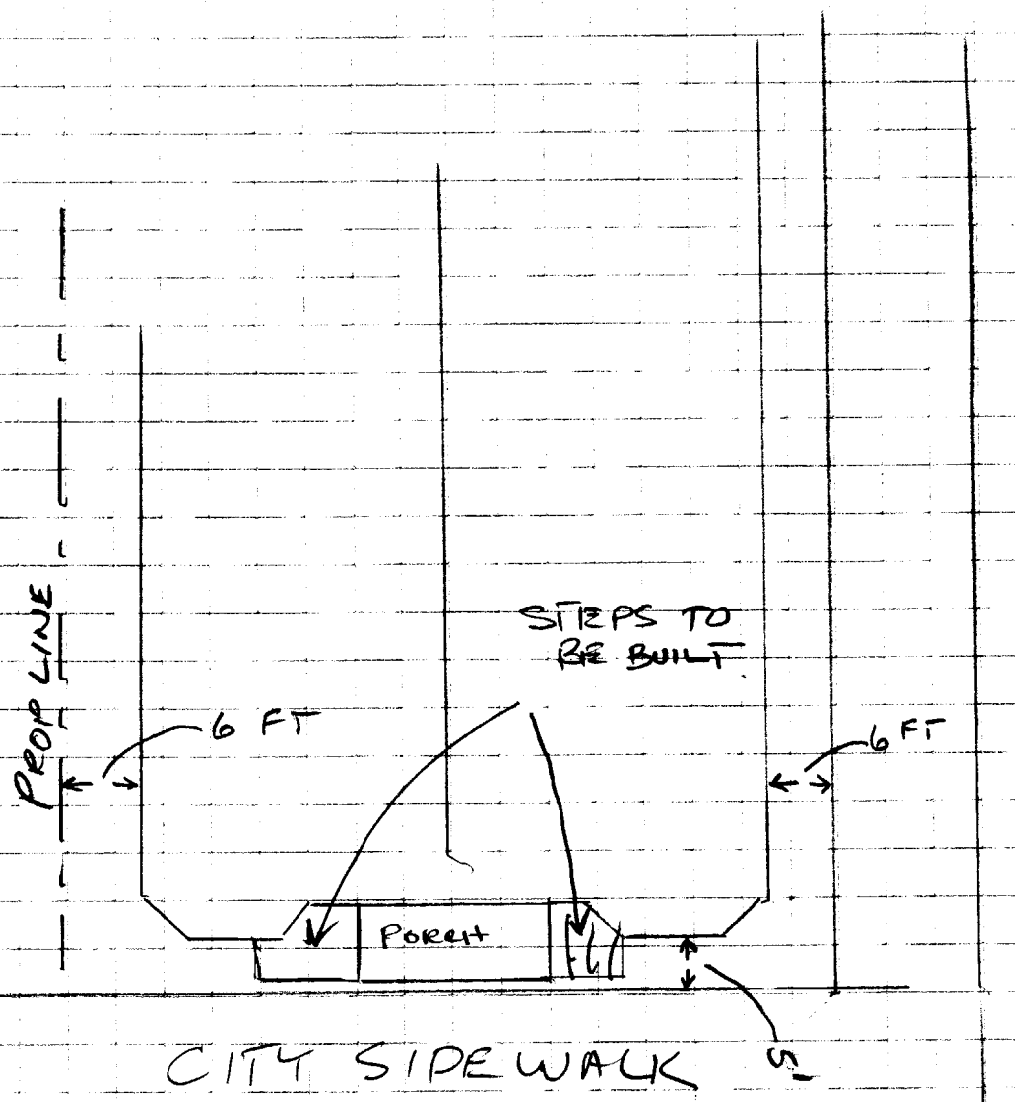

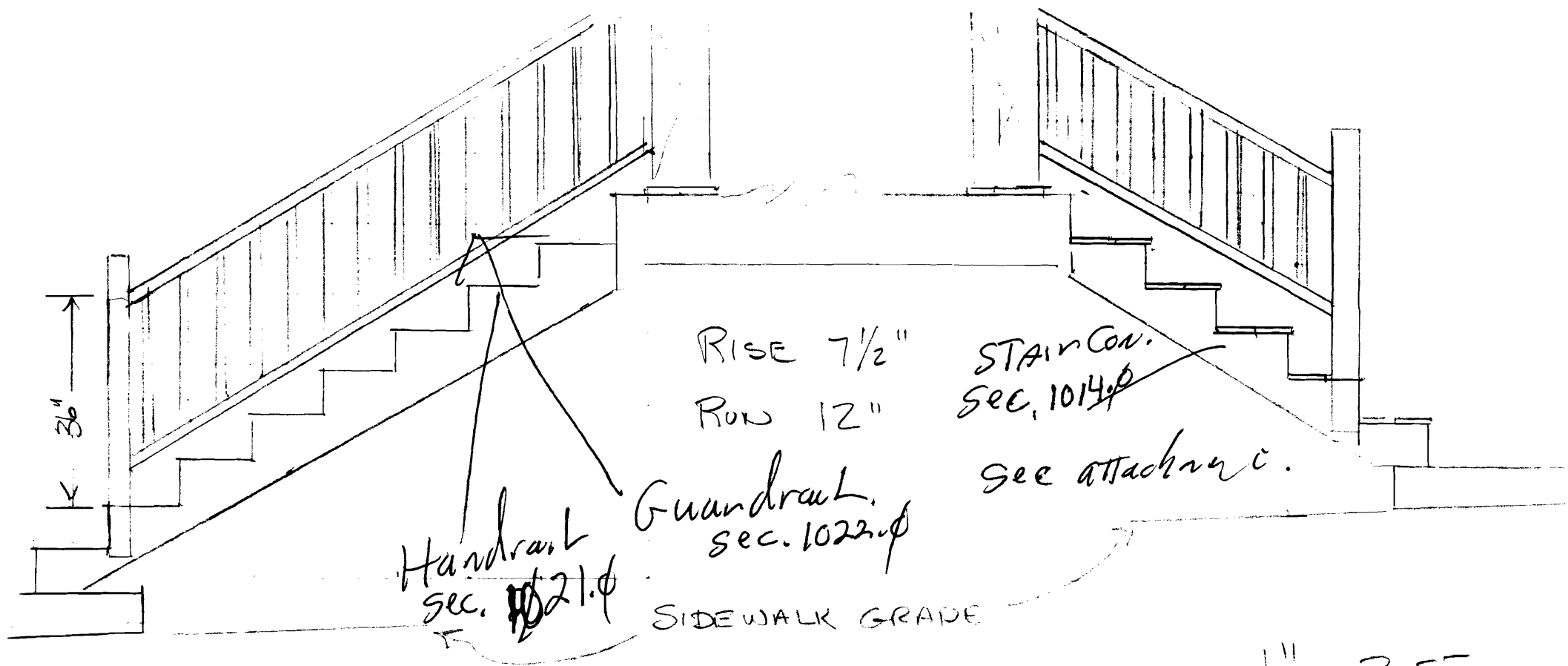

STREET ELEVATION
 30-32 STATE ST.

1" = 2 FT

- MATERIALS -
- STRINGERS 2X6 PT
 - POINTS 2X8 PT stock
 - TREADS (2) 5/4 X 6 PT
 - RISERS SELECT PINE
 - SKIRT BOARD SELECT PINE
 - POSTS 4 X 4 HEMLOCK
 - BOTTOM RAIL 2X4 PT
 - TOP RAIL 2X4 PINE
 - BALUSTER 1 1/2 X 1 1/2 PT

STRINGER DETAIL #30 SIDE

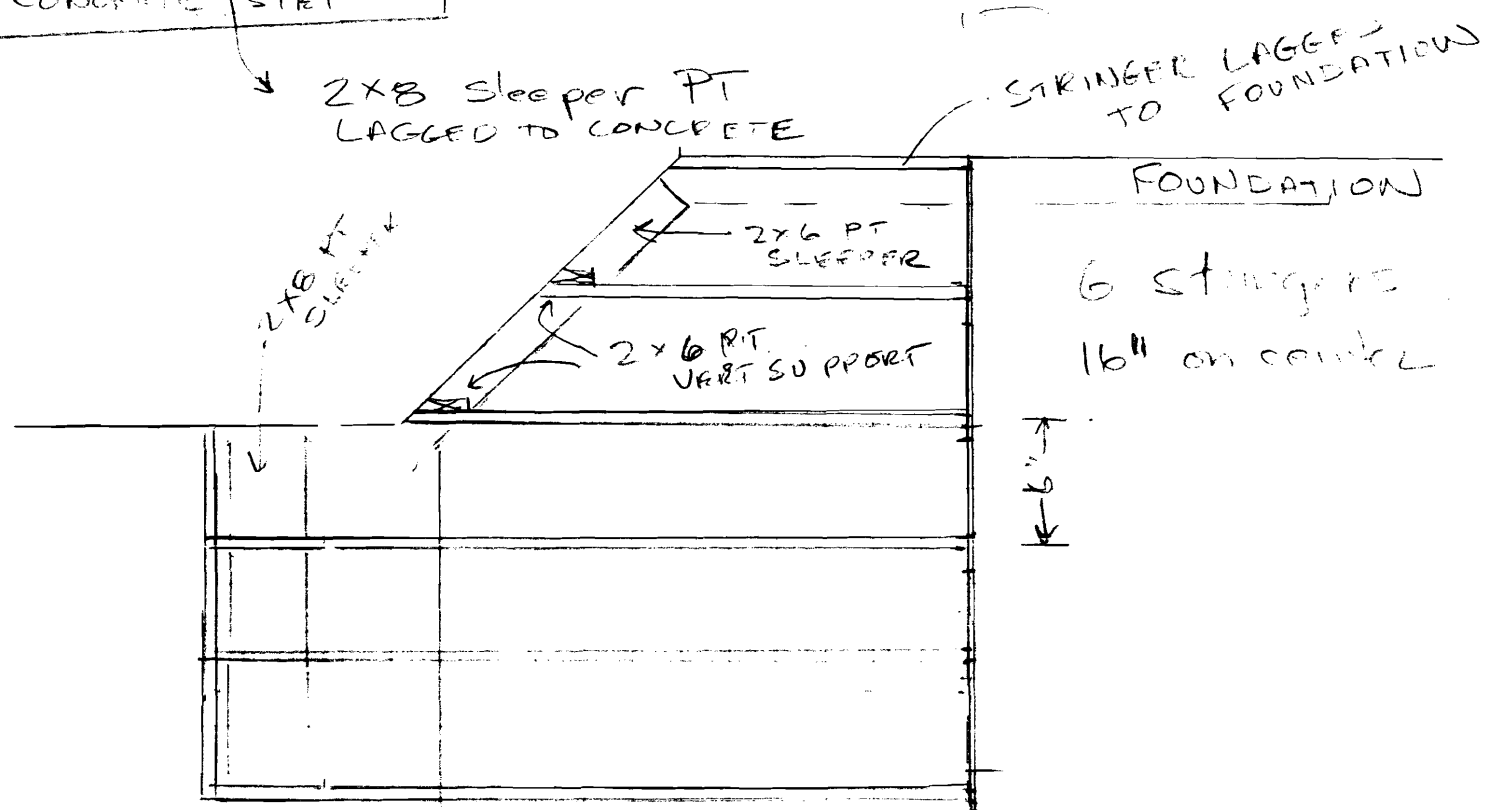
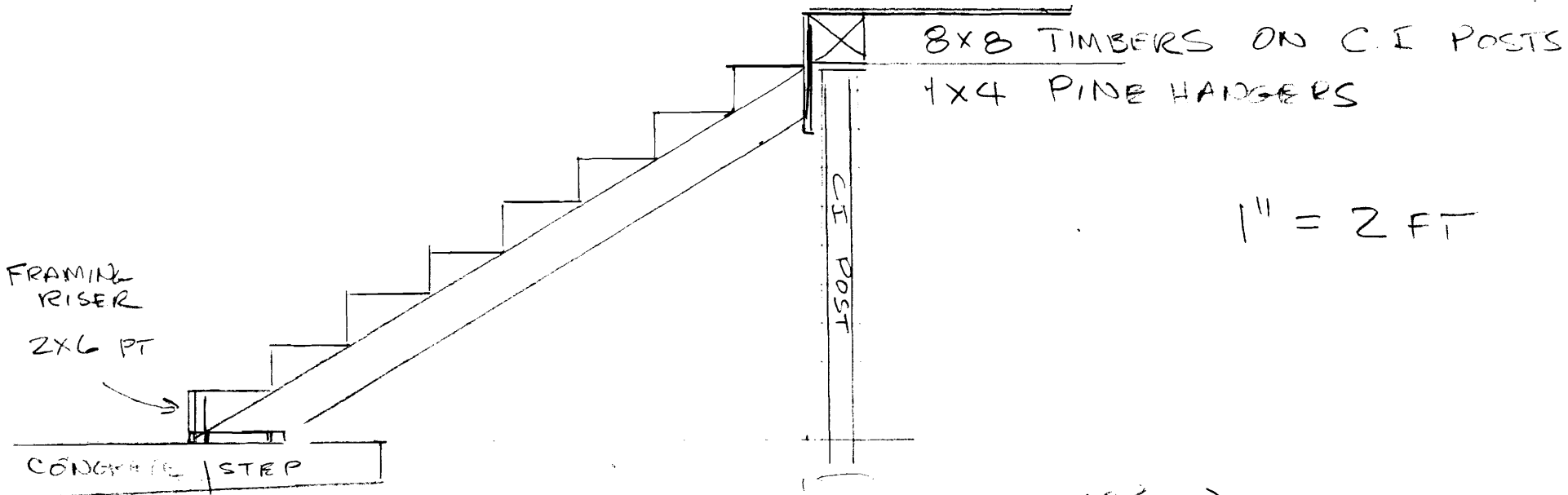

STRINGER DETAIL #32 SIDE

1" = 2 FT

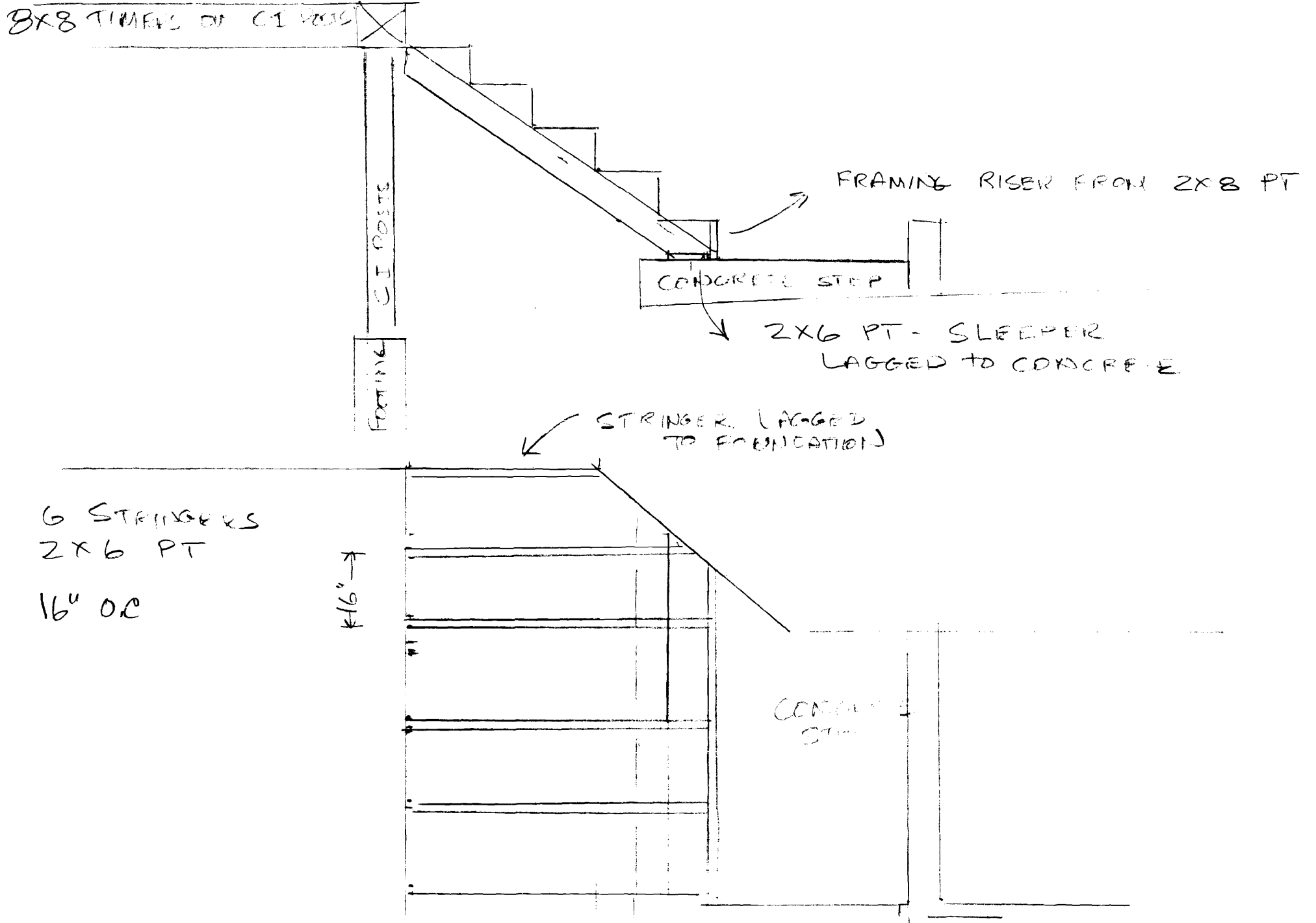



CITY OF PORTLAND, MAINE

Department of Building Inspection

_____ 20____

Received from _____ a fee

of _____ /100 Dollars \$ _____

for permit to install
erect
alter

at move
demolish _____ Est. Cost \$ _____

Handwritten:
= 1109
\$ - 144 C 105

Inspector of buildings
Per _____

THIS IS NOT A PERMIT

No work is to be started until PERMIT CARD is actually posted upon the premises. Acceptance of fee is no guarantee that permit will be granted. PRESERVE THIS RECEIPT. In case permit cannot be granted the amount of the fee will be refunded upon return of the receipt less \$5.00 or 10% whichever is greater.

- WHITE - Applicant's Copy
- YELLOW - Office Copy
- PINK - Auditors Copy