

**GRANT HAYS ASSOCIATES**  
 ARCHITECTURE & INTERIOR DESIGN  
 P.O. BOX 6179 FALMOUTH MAINE, 04103  
 207.871.5900 www.granthays.com

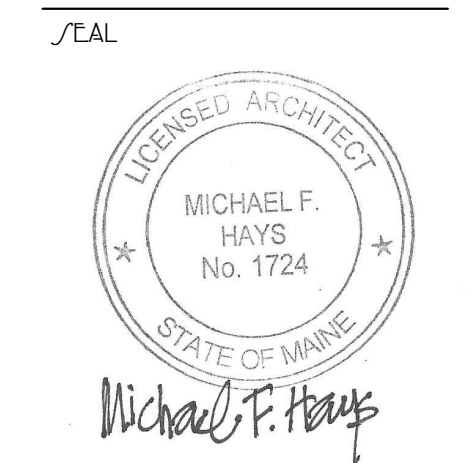

REVISION

PROJECT NAME

**3 UNIT APARTMENT BUILDING**  
**135 YORK STREET**  
 PEERLESS INVESTMENTS, LLC.  
 1 PORTLAND SQUARE  
 PORTLAND, MAINE 04101

SHEET

**SECTION & DETAILS**

DATE: 06 DEC 2017  
 SCALE: AS NOTED  
 DRAWN: JAM/MFH  
 JOB NO. -  
 SHEET -

**A6**  
 COPYRIGHT REPRODUCTION OR REVUE OF THIS DOCUMENT WITHOUT WRITTEN PERMISSION FROM GRANT HAYS ASSOCIATE IS PROHIBITED.

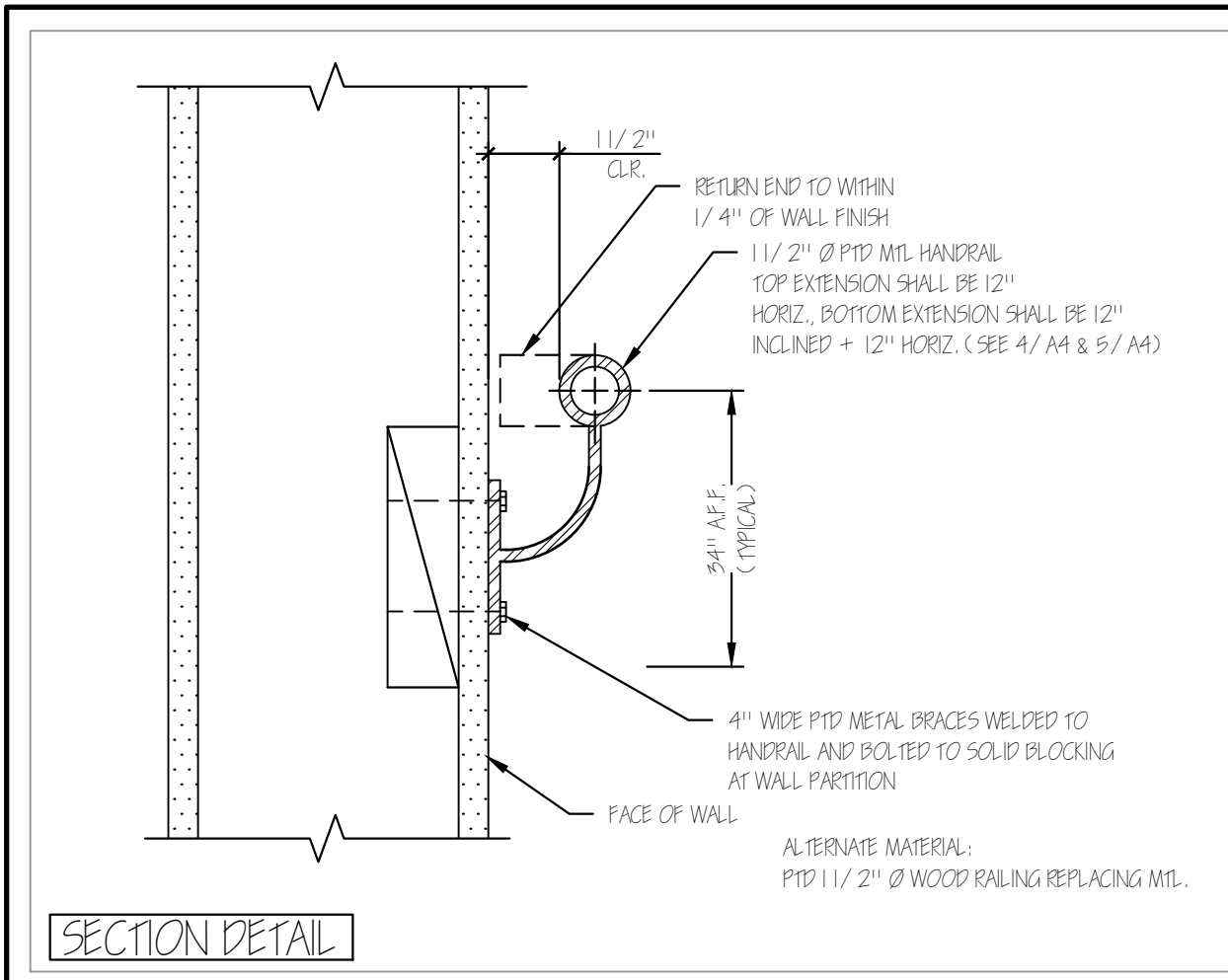

1 TYPICAL WALL HANDRAIL SECTION 3"=1'-0"

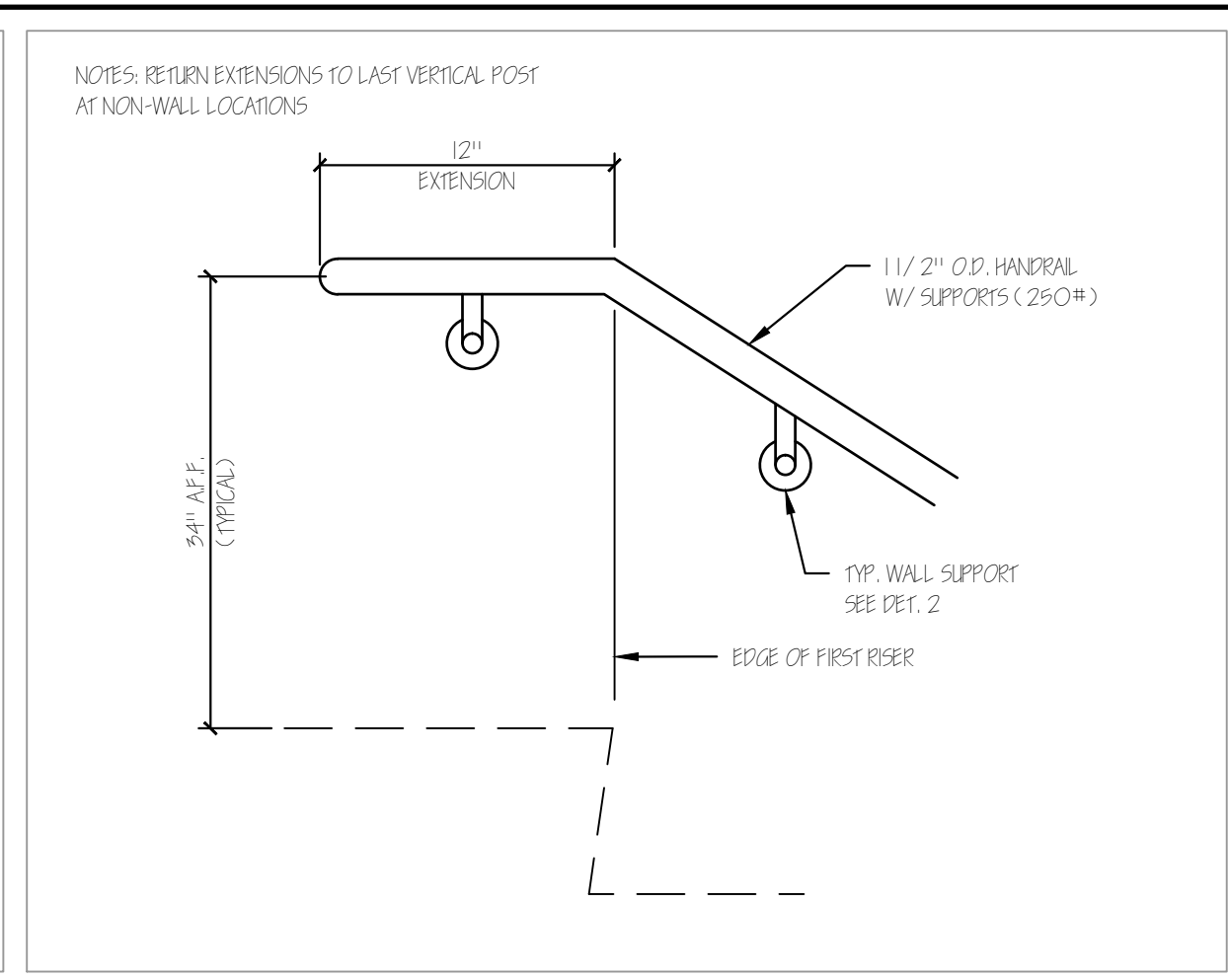

2 TYPICAL WALL HANDRAIL-TOP 3"=1'-0"

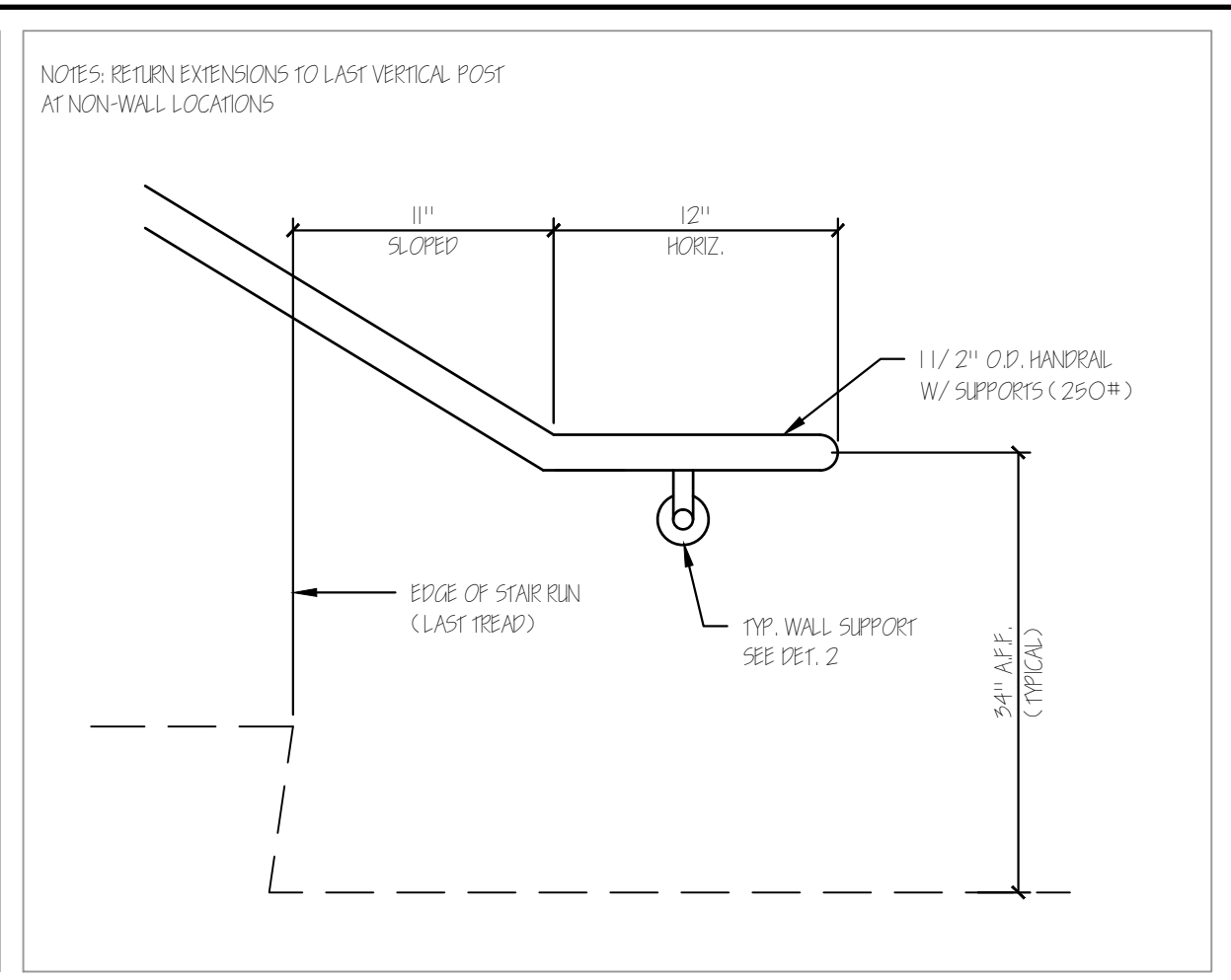

3 TYPICAL WALL HANDRAIL-BOTTOM 3"=1'-0"

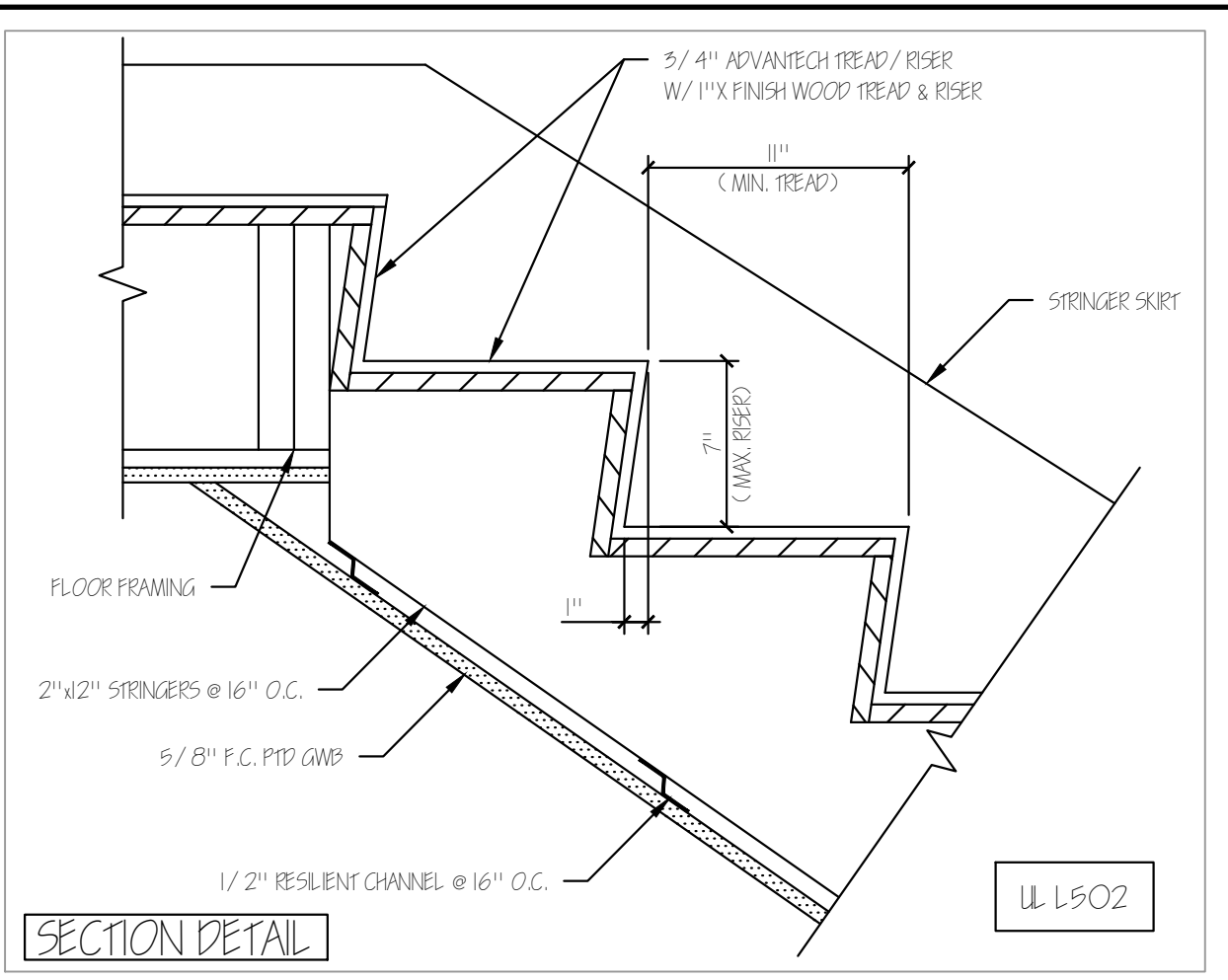

4 INTERIOR STAIR RISER/ TREAD DETAIL 1 1/2"=1'-0"

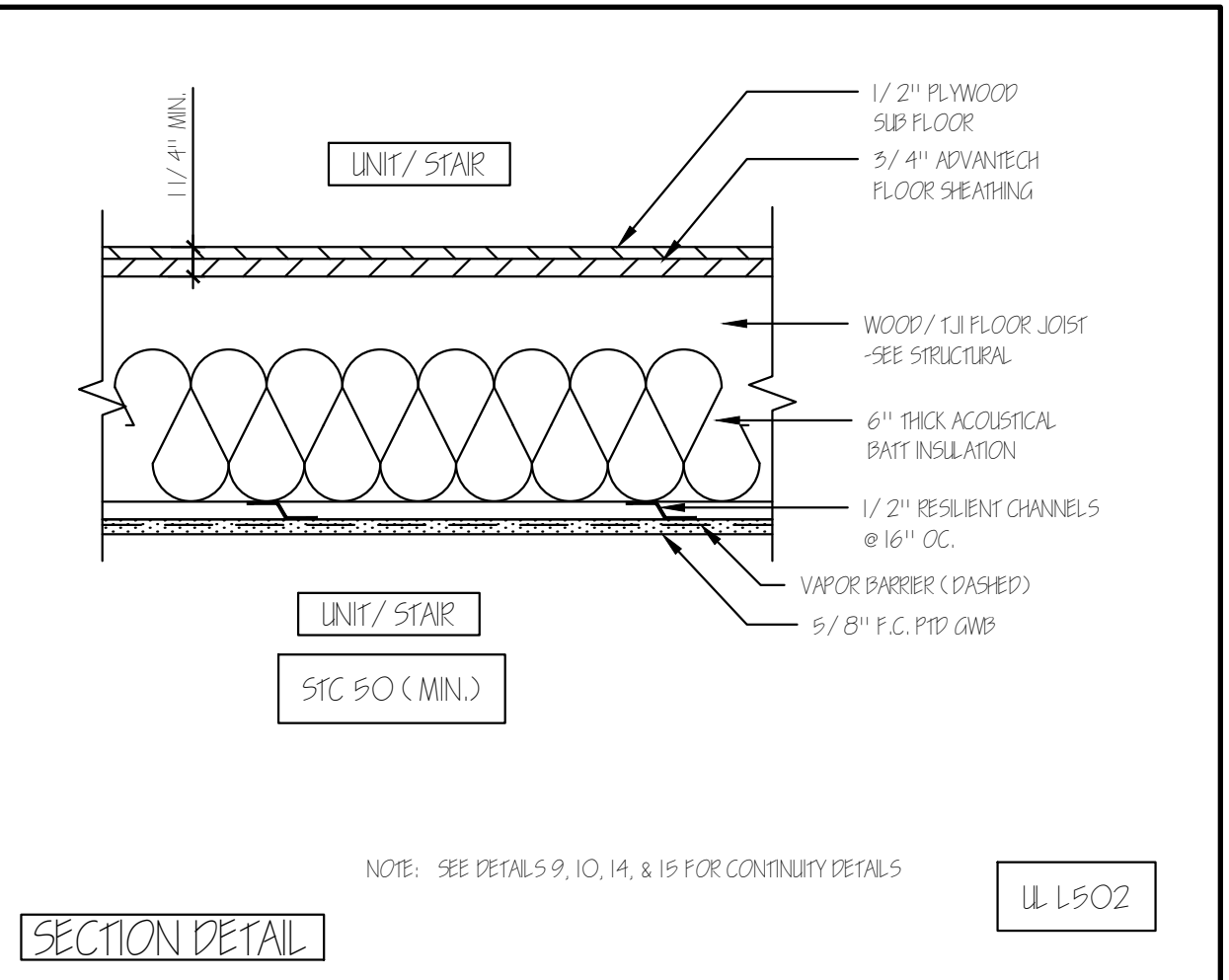

5 1 HR RATED FLOOR/ CEILING ASSEMBLY 1 1/2"=1'-0"

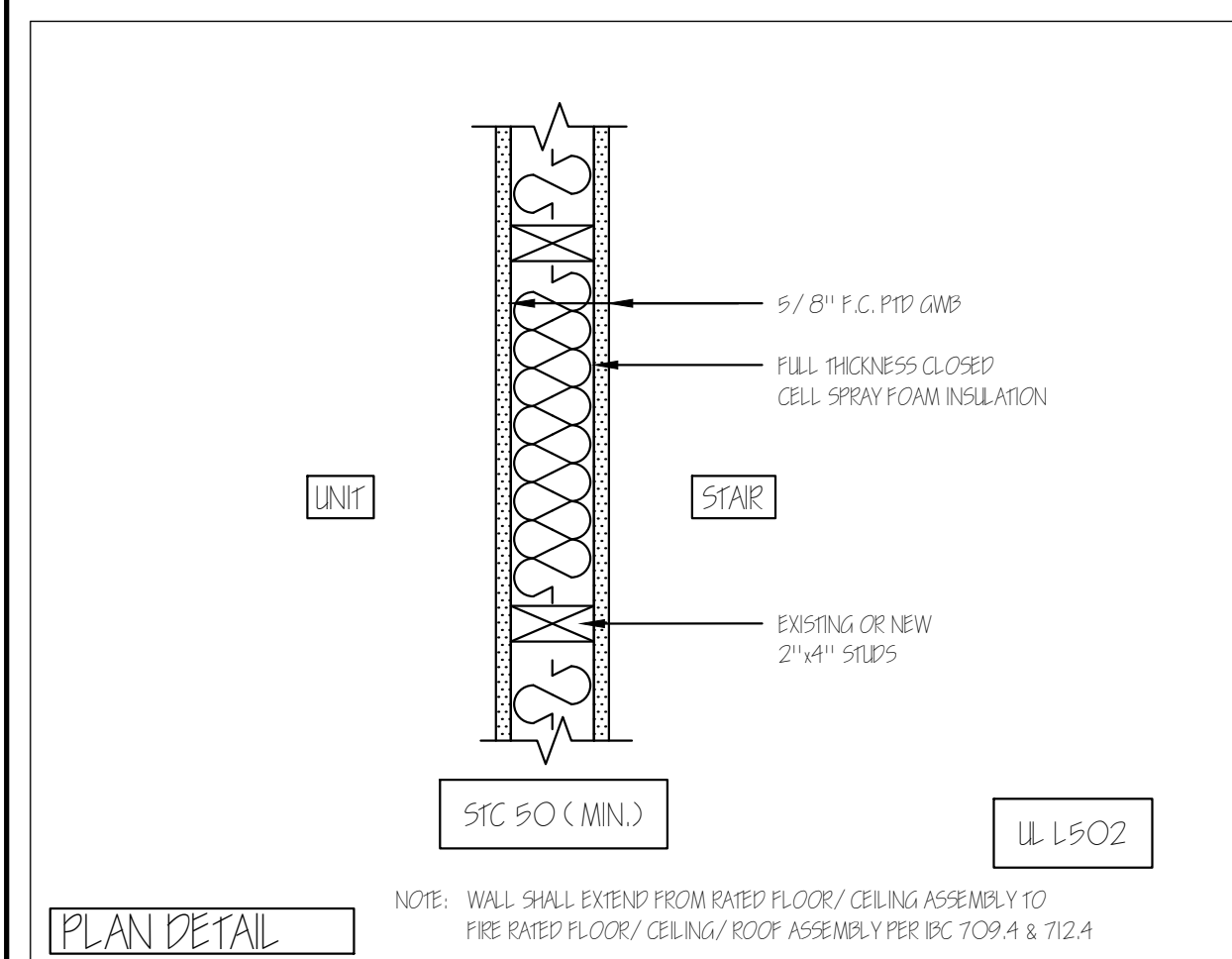

6 1 HR RATED PARTITION AT STAIR 1 1/2"=1'-0"

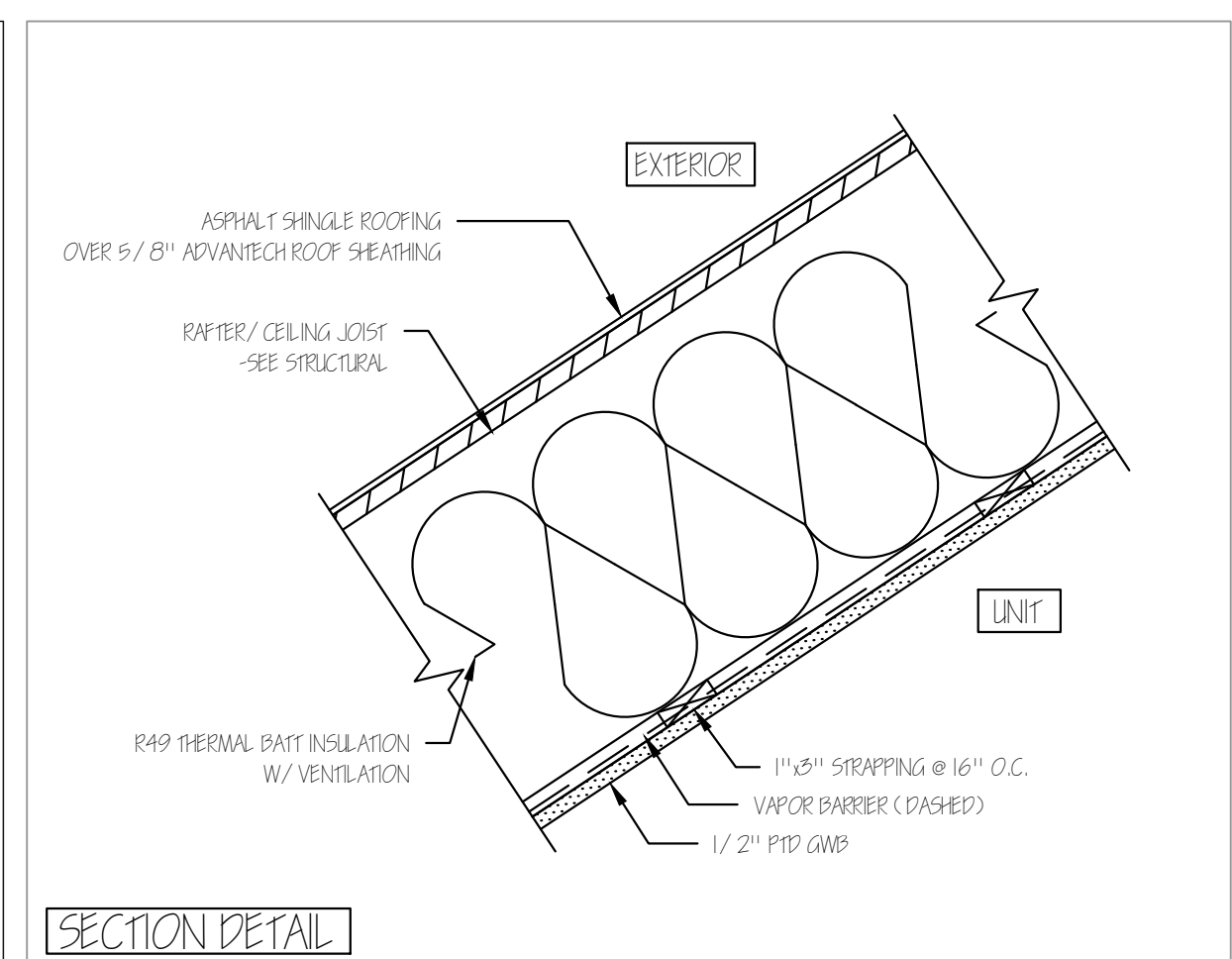

7 NON-RATED NEW ROOF 1 1/2"=1'-0"

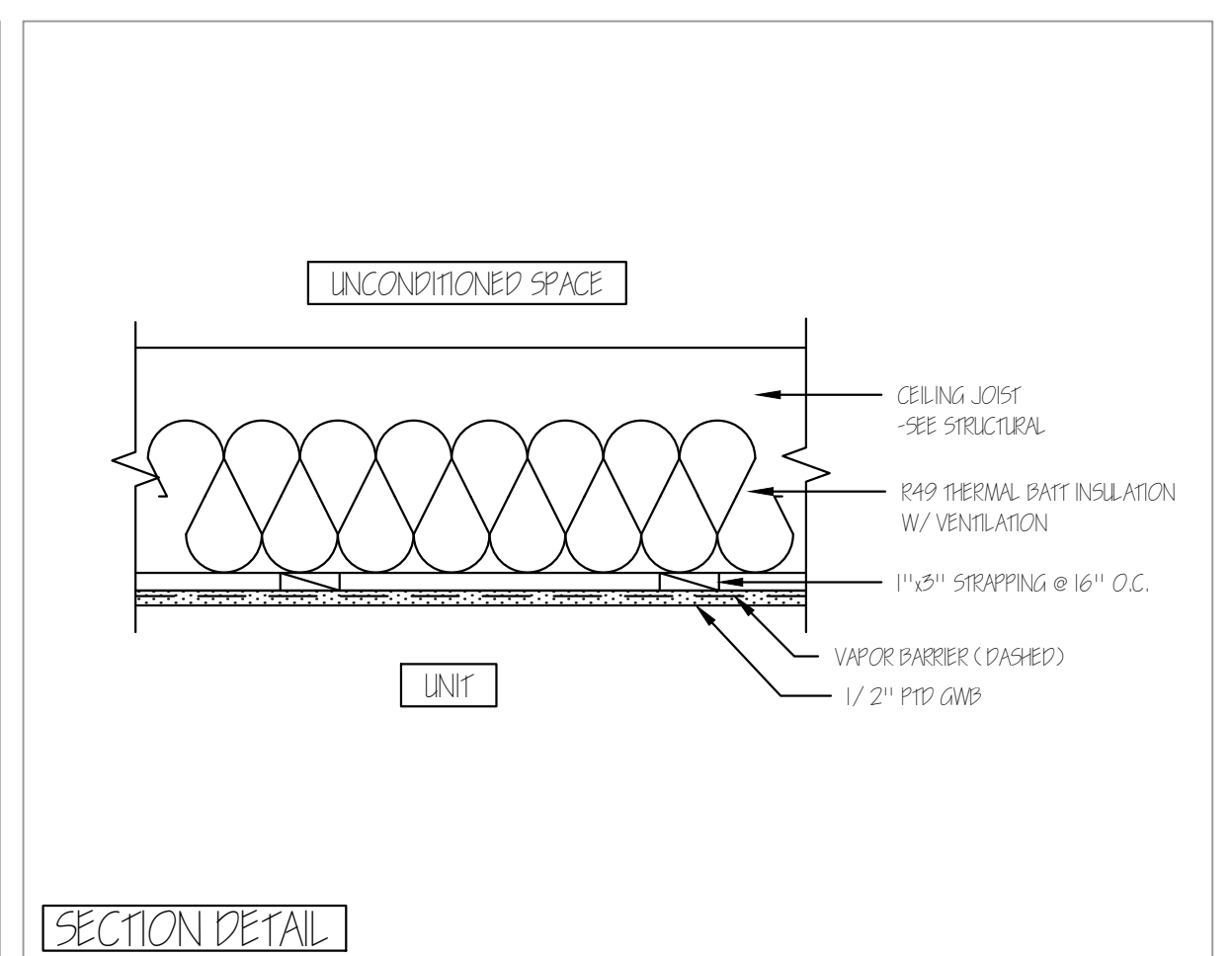

8 NON-RATED NEW CEILING 1 1/2"=1'-0"

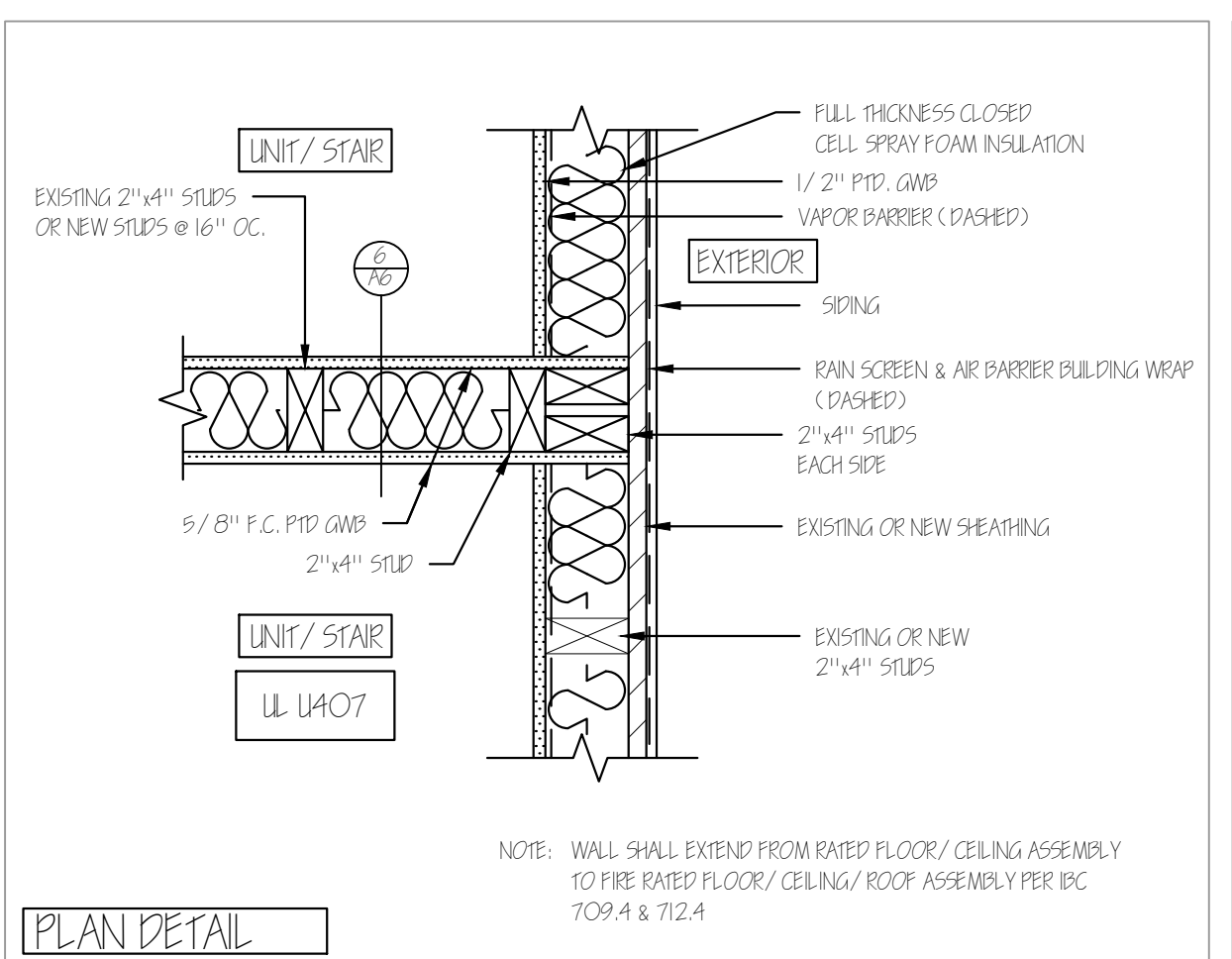

9 1 HR RATED PARTITION @ NON-RATED EXTERIOR WALL ASSEMBLY 1 1/2"=1'-0"

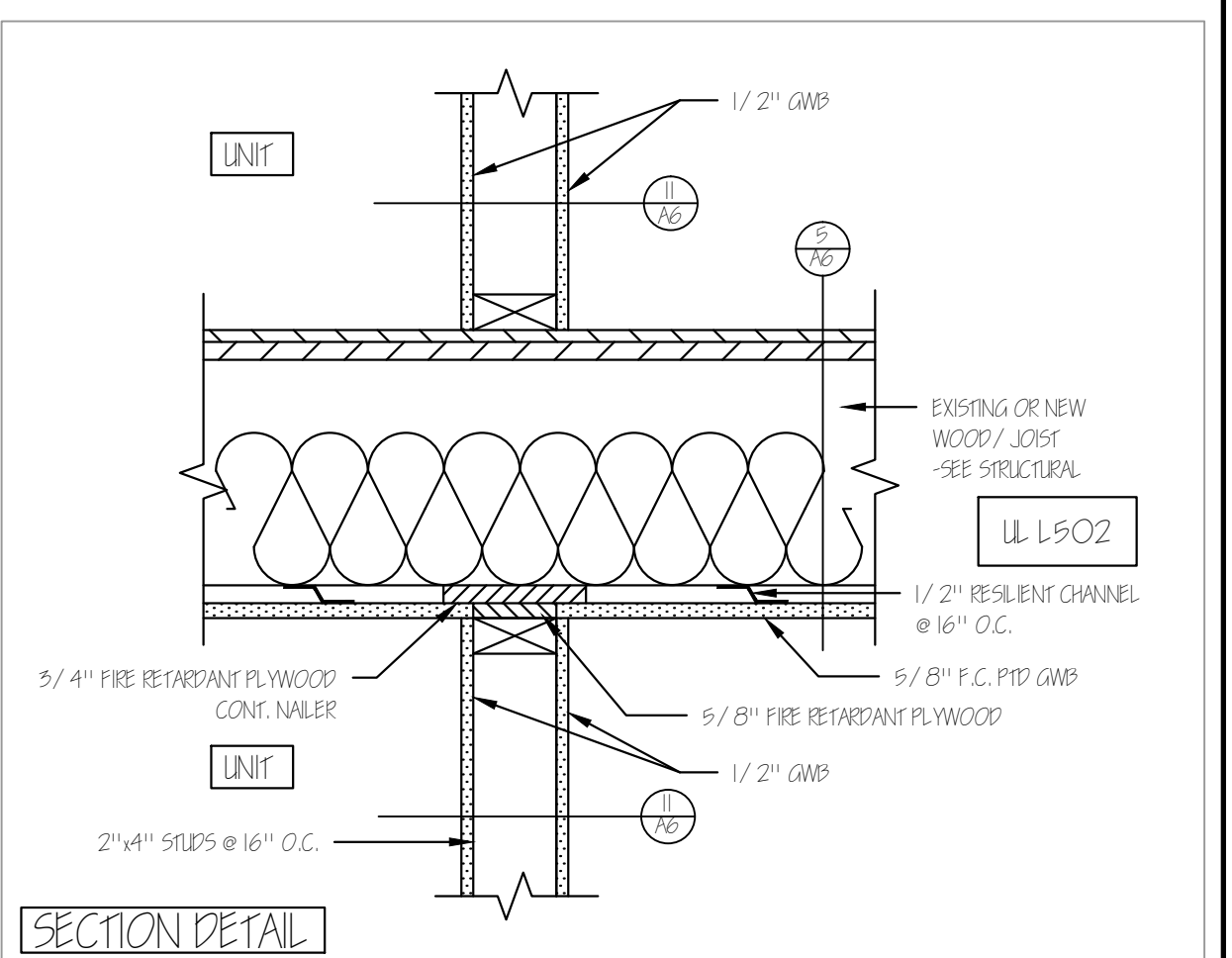

10 NON-RATED PARTITION @ 1 HR FIRE RATED FLOOR/ CEILING ASSEMBLY 1 1/2"=1'-0"

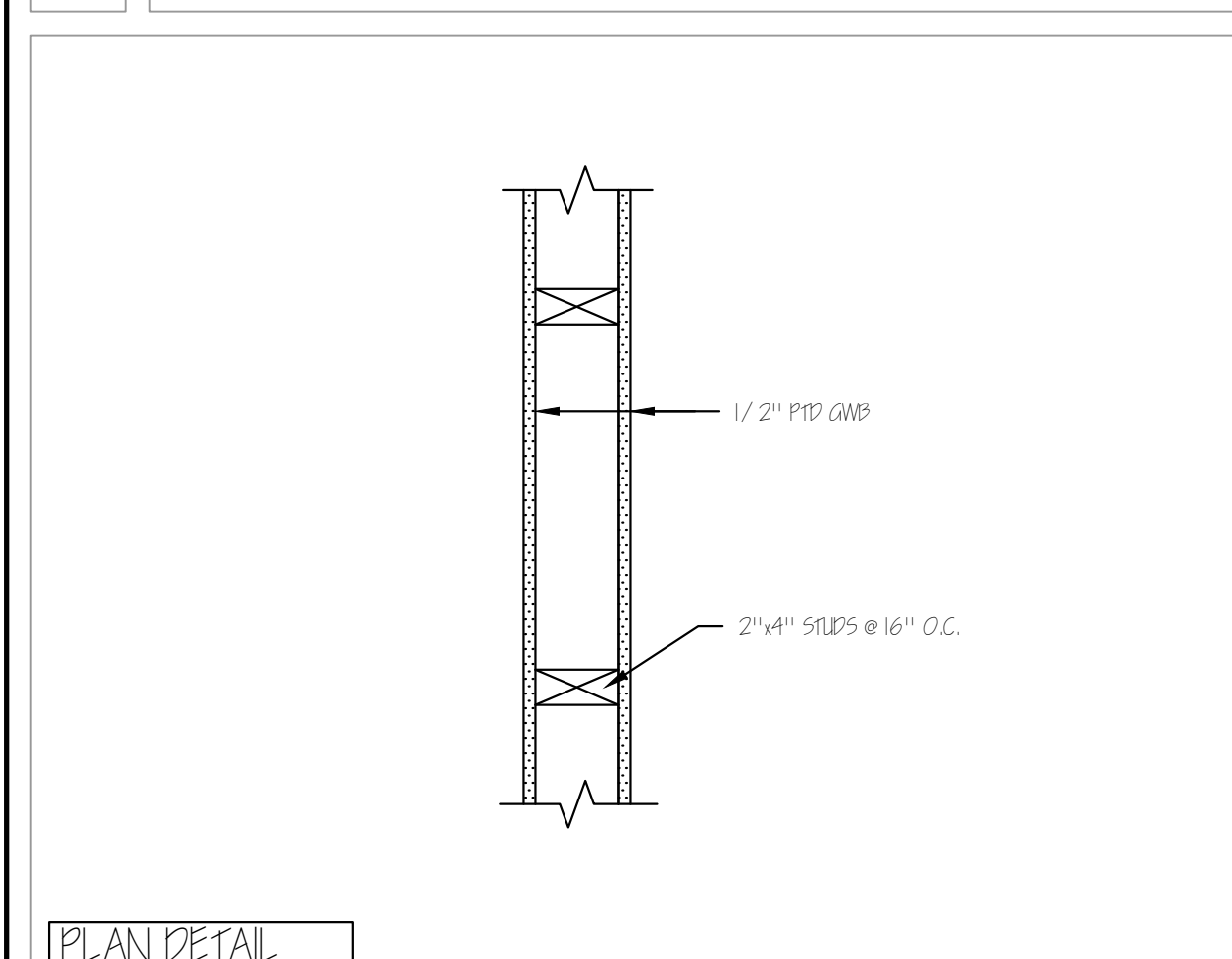

11 NON-RATED INTERIOR PARTITION 1 1/2"=1'-0"

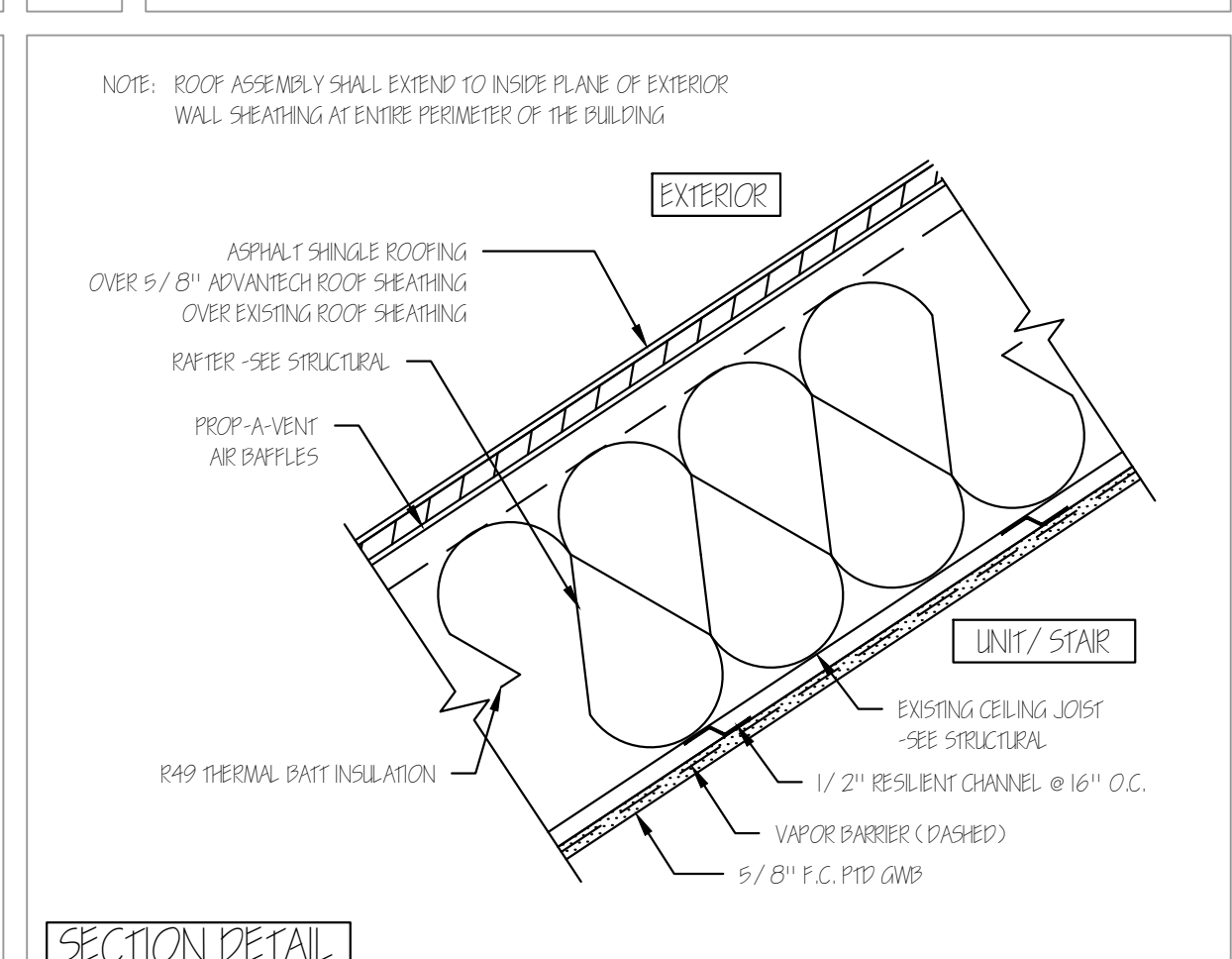

12 1 HR RATED CEILING ROOF ASSEMBLY 1 1/2"=1'-0"

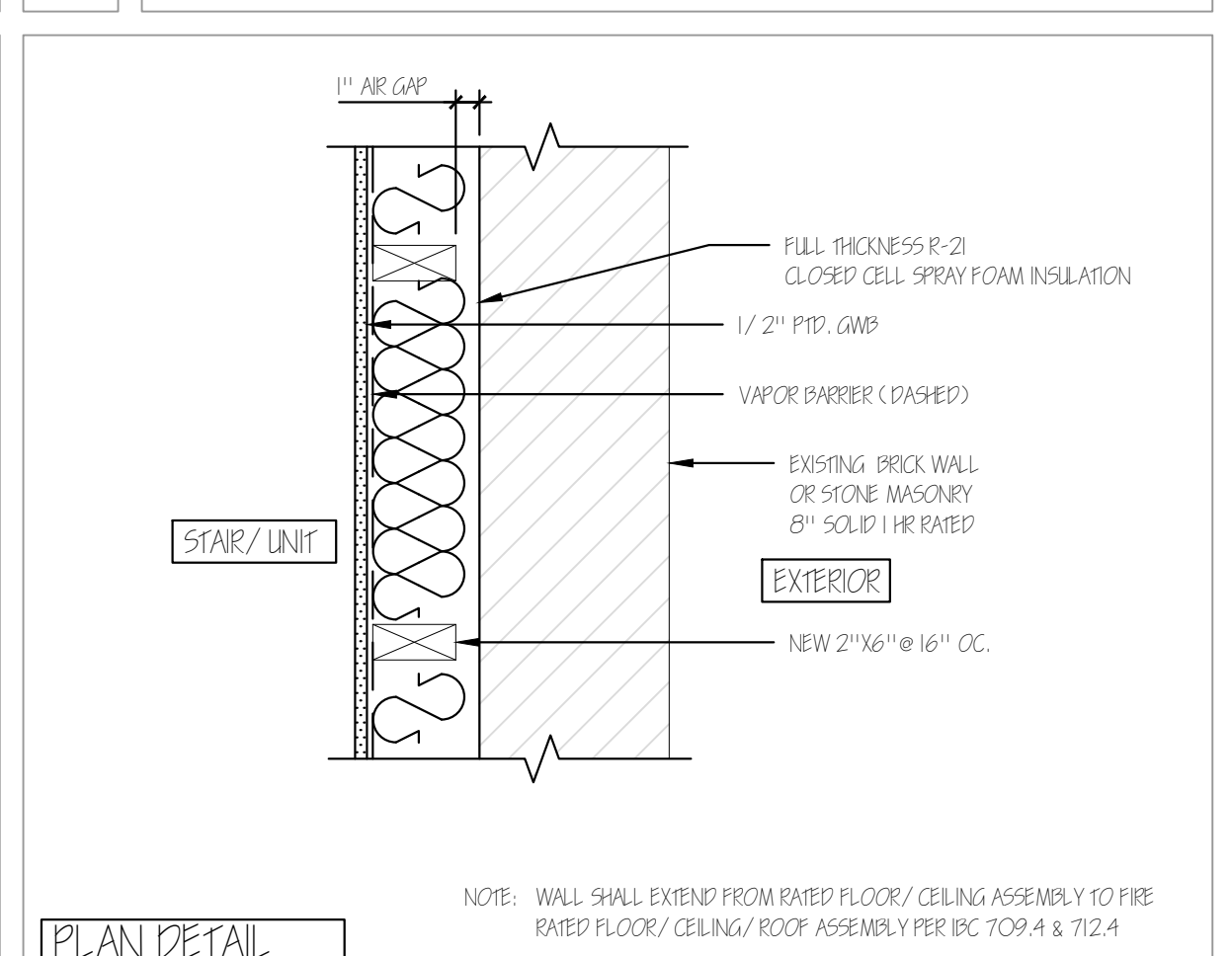

13 EXTERIOR WALL (BRICK/ STONE) 1 1/2"=1'-0"

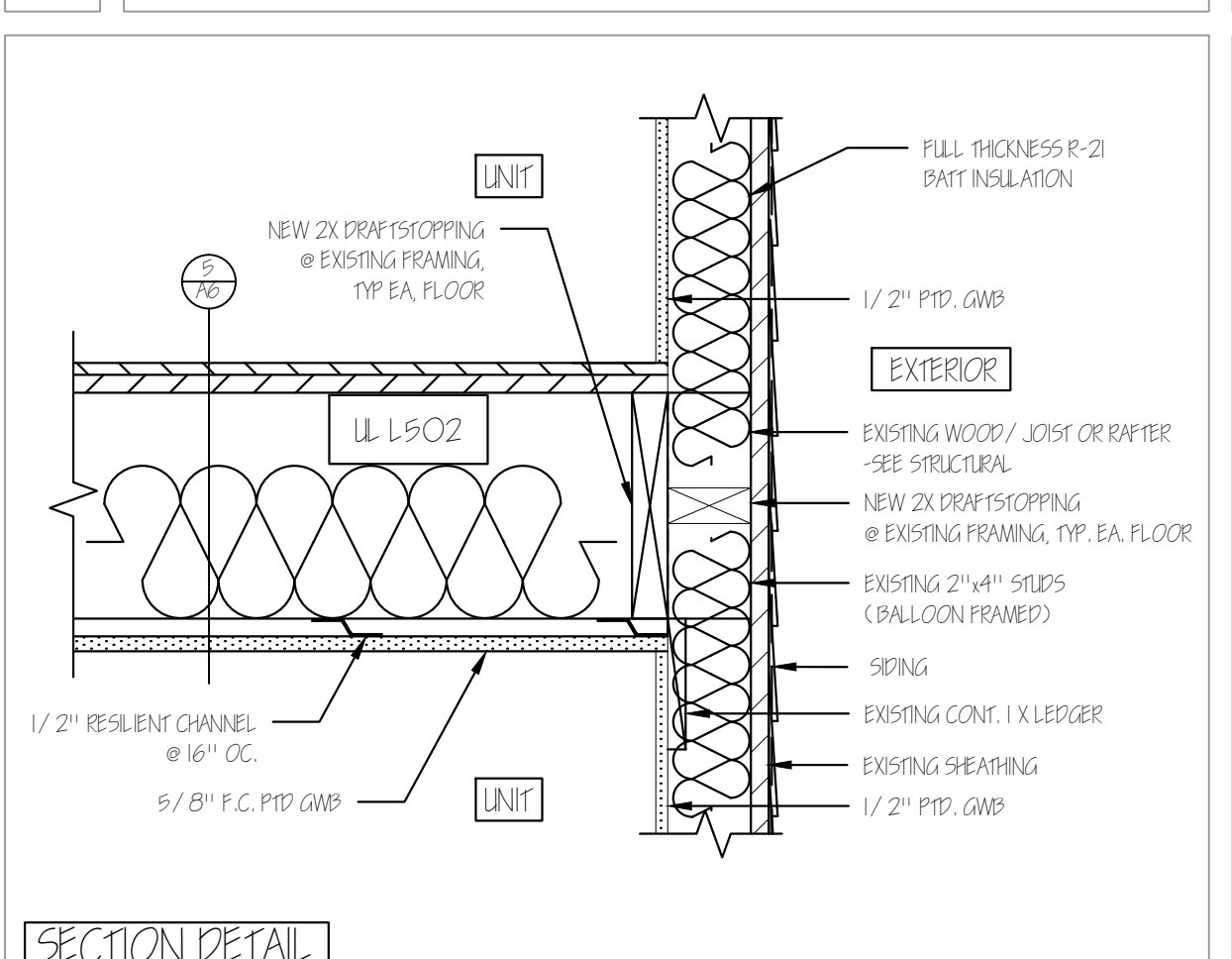

14 NON-RATED EXISTING EXTERIOR WALL 1 1/2"=1'-0"

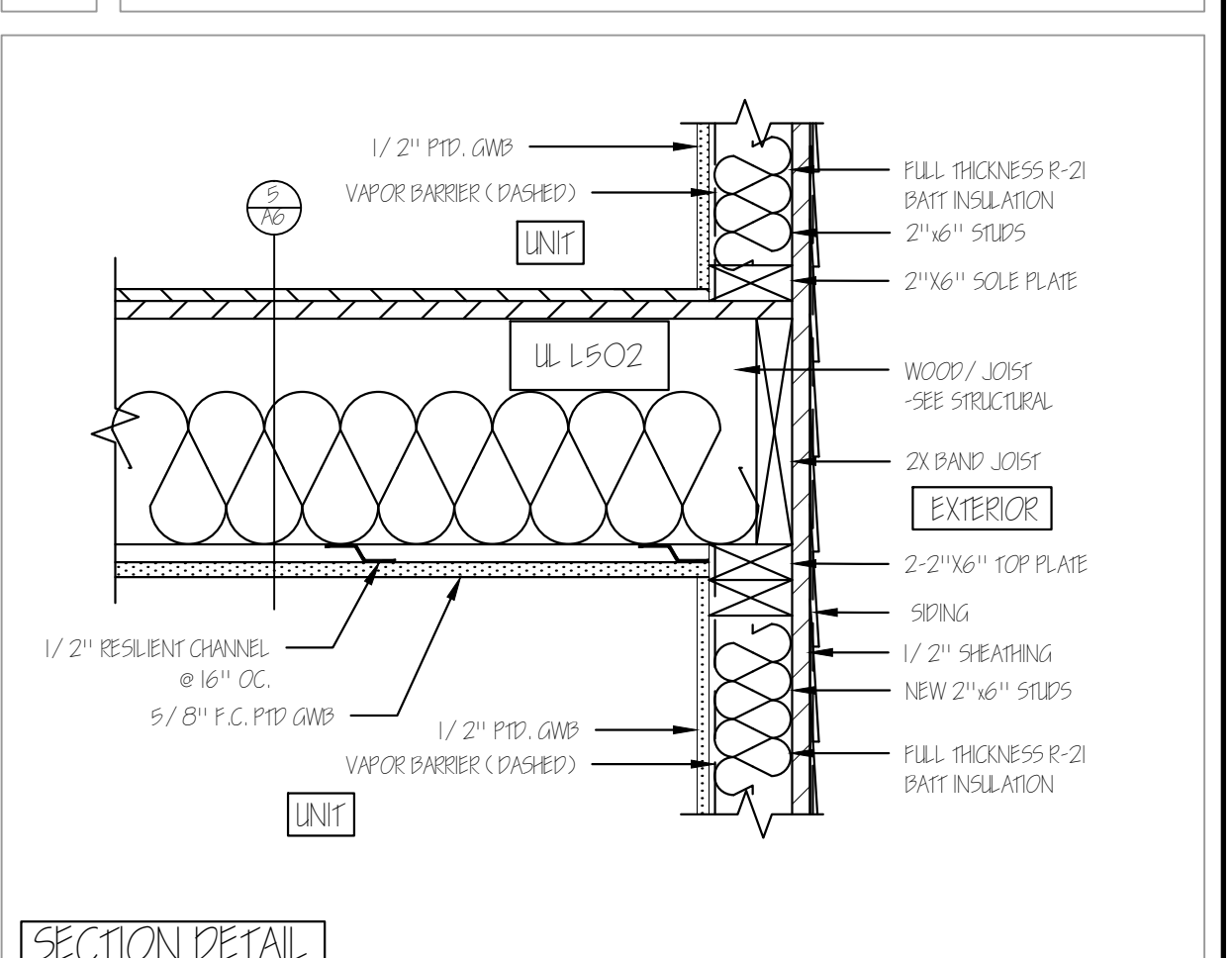

15 NON-RATED NEW EXTERIOR WALL 1 1/2"=1'-0"

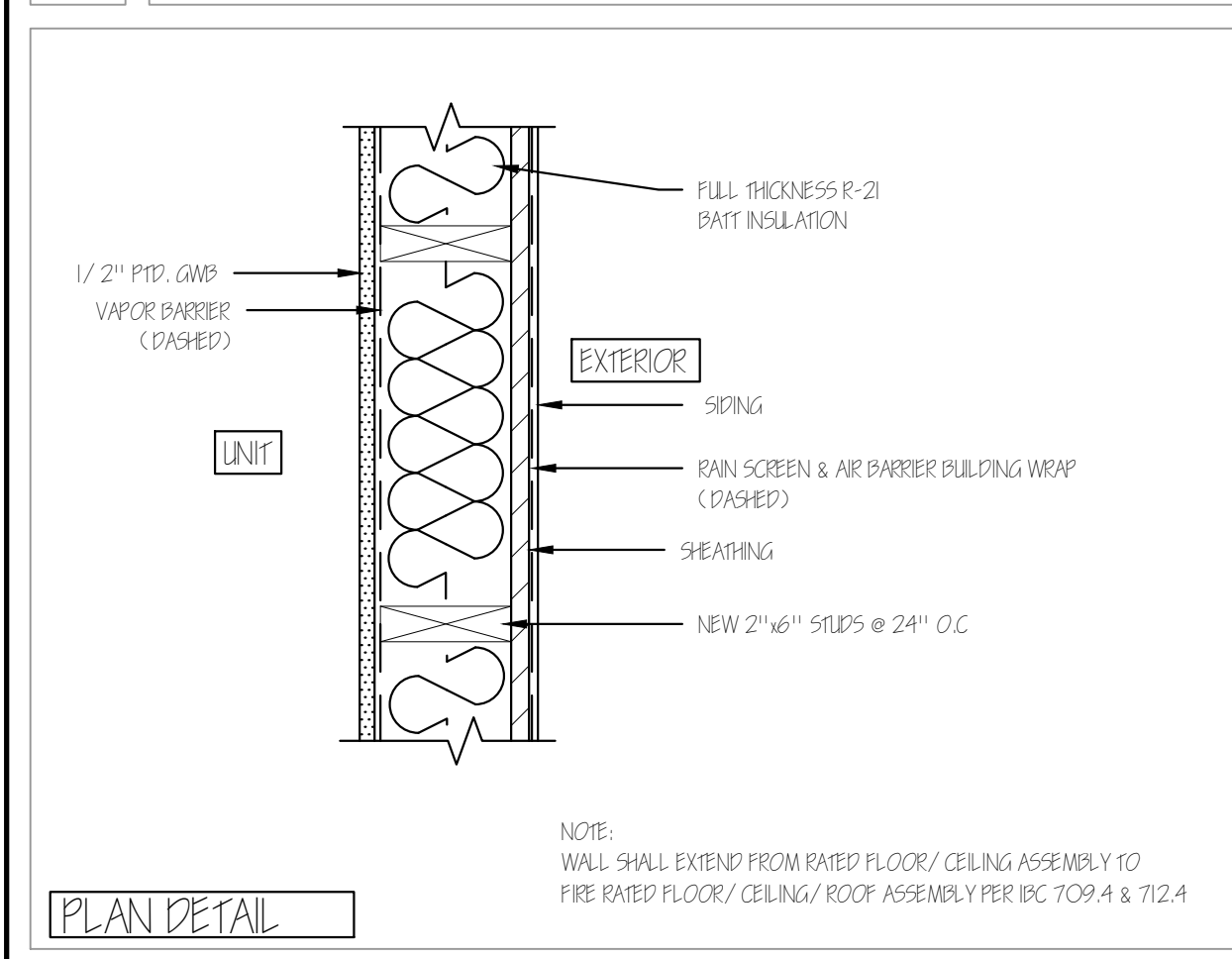

16 NON-RATED NEW EXTERIOR WALL 1 1/2"=1'-0"