

DISPLAY THIS CARD ON PRINCIPAL FRONTAGE OF WORK



# CITY OF PORTLAND BUILDING PERMIT



**This is to certify that**

HARBORVIEW DEVELOPMENT LLC /Cunningham  
Security Systems

**PERMIT ID:** 2012-65603

**Located at**

125 YORK ST

**CBL:** 044 A004001

has permission to **install a sprinkler supervisory system (fire alarm).**

provided that the person or persons, firm or corporation accepting this permit shall comply with all of the provisions of the Statues of Maine and of the Ordinances of the City of Portland regulating the construction, maintenance and use of the buildings and structures, and of the application on file in the department.

Notification of inspection and written permission procured before this building or part thereof is lathed or otherwise cloosed-in. 48 HOUR NOTICE IS REQUIRED.

A final inspection must be completed by owner before this building or part thereof is occupied. If a certificate of occupancy is required, it must be procured prior to occupancy.

  
Fire Prevention Officer

  
Code Enforcement Officer / Plan Reviewer

**THIS CARD MUST BE POSTED ON THE STREET SIDE OF THE PROPERTY  
THERE IS A PENALTY FOR REMOVING THIS CARD**

**BUILDING PERMIT INSPECTION PROCEDURES**  
Please call 874-8703 (ONLY)  
or email: [buildinginspections@portlandmaine.gov](mailto:buildinginspections@portlandmaine.gov)

With the issuance of this permit, the owner, builder or their designee is required to provide adequate notice to the city of Portland Inspections Services for the following inspections. Appointments must be requested 48 to 72 hours in advance of the required inspection. The inspection date will need to be confirmed by this office.

- **Please read the conditions of approval that is attached to this permit!! Contact this office if you have any questions.**
- **Permits expire in 6 months. If the project is not started or ceases for 6 months.**
- **If the inspection requirements are not followed as stated below additional fees may be incurred due to the issuance of a "Stop Work Order" and subsequent release to continue.**

**REQUIRED INSPECTIONS:**

Final - Fire

The project cannot move to the next phase prior to the required inspection and approval to continue, REGARDLESS OF THE NOTICE OF CIRCUMSTANCES.

IF THE PERMIT REQUIRES A CERTIFICATE OF OCCUPANCY, IT MUST BE PAID FOR AND ISSUED TO THE OWNER OR DESIGNEE BEFORE THE SPACE MAY BE OCCUPIED.

**City of Portland, Maine - Building or Use Permit**

389 Congress Street, 04101 Tel: (207) 874-8703, Fax: (207) 874-8716

<b>Permit No:</b> 201265603	<b>Date Applied For:</b> 12/12/2012	<b>CBL:</b> 044 A004001
--------------------------------	--	----------------------------

<b>Location of Construction:</b> 125 YORK ST	<b>Owner Name:</b> HARBORVIEW DEVELOPMENT	<b>Owner Address:</b> PO BOX 8816	<b>Phone:</b> (207) 846-3350
<b>Business Name:</b>	<b>Contractor Name:</b> Cunningham Security Systems	<b>Contractor Address:</b> 10 Prince Point Road Yarmouth	<b>Phone:</b> (207) 846-3350
<b>Lessee/Buyer's Name</b>	<b>Phone:</b>	<b>Permit Type:</b> Fire Alarm System	

<b>Proposed Use:</b> Same: Bldg 1: 12 residential condos; Bldg 2: 7 residential condos	<b>Proposed Project Description:</b> install a sprinkler supervisory system (fire alarm).
---	--

<b>Dept:</b> Zoning	<b>Status:</b> Approved	<b>Reviewer:</b> Marge Schmuckal	<b>Approval Date:</b> 12/12/2012
<b>Note:</b>	<b>Ok to Issue:</b> <input checked="" type="checkbox"/>		

<b>Dept:</b> Fire	<b>Status:</b> Approved w/Conditions	<b>Reviewer:</b> Ben Wallace Jr	<b>Approval Date:</b> 01/01/2013
<b>Note:</b> Sprinkler supervisory system with occupant notification.	<b>Ok to Issue:</b> <input checked="" type="checkbox"/>		

- 1) Sprinkler supervisory systems shall monitor for water flow and sprinkler supervisory signals via an approved fire alarm panel to central station. One smoke detector shall be located over the panel, a manual pull station located at the front door, and an audible water flow alarm provided.
- 2) A master box connection is not authorized for this building.
- 3) Fire Alarm system shall be maintained. If system is to be off line over 4 hours a fire watch shall be in place. Dispatch notification required 874-8576.
- 4) System acceptance and commissioning must be coordinated with alarm and suppression system contractors and the Fire Department. Call 874-8703 to schedule.
- 5) A 4100 series Knox Box is required. A hinged 3200 series Knox Box will be permitted if the building is master keyed.
- 6) All fire alarm records required by NFPA 72 should be stored in an approved cabinet located at the FACP labeled "FIRE ALARM RECORDS".
- 7) Central/Supervising Station monitoring for addressable fire alarm systems shall be by point.
- 8) Records cabinet, FACP, annunciator(s), and pull stations shall be keyed alike.
- 9) All smoke detectors and smoke alarms shall be photoelectric.
- 10) In field installation shall be installed per code as conditions dictate.
- 11) The fire alarm system shall be certified by a master fire alarm company and have a new fire alarm inspection sticker.
- 12) The installation shall comply with the following:  
 City of Portland Chapter 10, Fire Prevention and Protection;  
 NFPA 1, Fire Code (2009 edition), as amended by City Code;  
 NFPA 101, Life Safety Code (2009 edition), as amended by City Code;  
 City of Portland Fire Department Rules and Regulations;  
 NFPA 72, National Fire Alarm and Signaling Code (2010 edition), as amended by Fire Department Rules and Regulations; and  
 NFPA 70, National Electrical Code (2011 edition) as amended by the State of Maine.

**City of Portland, Maine - Building or Use Permit Application**

389 Congress Street, 04101 Tel: (207) 874-8703, Fax: (207) 874-8716

Permit No: 2012-65603	Issue Date:	CBL: 044 A004001
--------------------------	-------------	---------------------

Location of Construction: 125 YORK ST	Owner Name: HARBORVIEW DEVELOPMENT	Owner Address: PO BOX 8816	Phone: (207) 846-3350
Business Name:	Contractor Name: Cunningham Security Systems	Contractor Address: 10 Prince Point Road Yarmouth	Phone: (207) 846-3350
Lessee/Buyer's Name	Phone:	Permit Type: Fire Alarm System	Zone: R6
Past Use: Existing 12 residential condo building and a separate building under construction for 7 residential condos on same lot	Proposed Use: Same: Bldg 1: 12 residential condos; Bldg 2: 7 residential condos	Permit Fee: \$80.00	Cost of Work: \$6,000.00
Proposed Project Description: To install fire alarm in Bldg 2 with 7 condos under construction		FIRE DEPT: 1/1/13 <input checked="" type="checkbox"/> Approved <input type="checkbox"/> Denied <input type="checkbox"/> N/A	INSPECTION: Use Group: Type:
		Signature: <i>[Signature]</i> (SB)	Signature:
PEDESTRIAN ACTIVITIES DISTRICT (P.A.D.)			
Action: <input type="checkbox"/> Approved <input type="checkbox"/> Approved w/Conditions <input type="checkbox"/> Denied			
		Signature:	Date:

Permit Taken By: gg	Date Applied For: 12/12/2012	<b>Zoning Approval</b>		
<p>1. This permit application does not preclude the Applicant(s) from meeting applicable State and Federal Rules.</p> <p>2. Building permits do not include plumbing, septic or electrical work.</p> <p>3. Building permits are void if work is not started within six (6) months of the date of issuance. False information may invalidate a building permit and stop all work..</p>		<b>Special Zone or Reviews</b> <input type="checkbox"/> Shoreland <input type="checkbox"/> Wetland <input type="checkbox"/> Flood Zone <input type="checkbox"/> Subdivision <input type="checkbox"/> Site Plan Maj <input type="checkbox"/> Minor <input type="checkbox"/> MM <input type="checkbox"/> Date: <i>12/12/12</i>	<b>Zoning Appeal</b> <input type="checkbox"/> Variance <input type="checkbox"/> Miscellaneous <input type="checkbox"/> Conditional Use <input type="checkbox"/> Interpretation <input type="checkbox"/> Approved <input type="checkbox"/> Denied Date:	<b>Historic Preservation</b> <input checked="" type="checkbox"/> Not in District or Landmark <input type="checkbox"/> Does Not Require Review <input type="checkbox"/> Requires Review <input type="checkbox"/> Approved <input type="checkbox"/> Approved w/Conditions <input type="checkbox"/> Denied Date:

**CERTIFICATION**

I hereby certify that I am the owner of record of the named property, or that the proposed work is authorized by the owner of record and that I have been authorized by the owner to make this application as his authorized agent and I agree to conform to all applicable laws of this jurisdiction. In addition, if a permit for work described in the application is issued, I certify that the code official's authorized representative shall have the authority to enter all areas covered by such permit at any reasonable hour to enforce the provision of the code(s) applicable to such permit.

SIGNATURE OF APPLICANT	ADDRESS	DATE	PHONE
RESPONSIBLE PERSON IN CHARGE OF WORK, TITLE		DATE	PHONE

Emailed & electronic copy



# Fire Alarm Permit

If you or the property owner owes real estate or property taxes or user charges on any property within the city, payment arrangements must be made before permits of any kind are accepted.

Installation address: 121 York Street CBL: 44-A-4-1

Exact location: (within structure) Sprinkler room

Type of occupancy(s) (NFPA & ICC): 7 unit condominium

Building owner: Harborview Development LLC

System Designer (point of contact): Must be Michael Major

Designer phone: 207-846-3350 E-mail: mmajor@cunninghamsecurity.ca

Installing contractor: Cunningham Security Certificate of Fitness No: 1004

Contractor phone: 207-846-3350 E-mail: mmajor@cunninghamsecurity.ca

This is a new application: YES  NO  New AES Master Box: YES  NO   
(Include Master Box approval form)

Amendment to an existing permit: YES  NO  Permit no: \_\_\_\_\_

**The following documents shall be provided with this application:**

- Floor plans
- Wiring diagram
- Annunciator details
- Input/ Output Matrix
- Equipment data sheets
- Electrical Permit Pulled (check alarm/com)
- Scope of Work
- 11 1/2 x 17s
- pdf copy (may be e-mailed)
- Designer qualifications
- Battery/ voltage drop calcs

Master box approval only: YES  NO   
(If yes check *New AES Master Box* above)

COST OF WORK: \$16,000.00

PERMIT FEE: 80.00  
(\$10 PER \$1,000 + \$30 FOR THE FIRST \$1,000)

**RECEIVED**

**DEC 12 2012**

Dept. of Building Inspections  
City of Portland Maine

The **designer** shall be the responsible party for this application. Download a new copy of this application at [www.portlandmaine.gov/fire](http://www.portlandmaine.gov/fire) for every submittal. Submit all plans in electronic PDF in addition to readable 11 1/2 x 17s to the Building Inspections Department, 389 Congress Street, Room 315, Portland, Maine 04101.

Prior to acceptance of any fire alarm system, a complete commissioning and acceptance test must be coordinated with all fire system contractors and the Fire Department, and proper documentation of such test(s) provided.

All installation(s) must comply with the *City of Portland Technical Standard for Signaling Systems for the Protection of Life and Property*, available at [www.portlandmaine.gov/fire](http://www.portlandmaine.gov/fire).

Applicant signature: [Signature] Date: 12-10-12

# CUNNINGHAM

## Security Systems

10 Princes Point Road • Yarmouth, Maine 04096  
(207) 846-3350 • Fax (207) 846-6080 • (800) 210-0257

12/10/12

Lieutenant Benjamin Wallace, Jr.  
Portland Fire Department  
380 Congress Street  
Portland Maine 04101

Please find attached a permit application for the property located at 121 York Street. This is a new installation in a 7 unit residential condominium building with a fully supervised automatic sprinkler system.



Michelle Perkins, Operations Manager

Planning • Installation • Monitoring • Service  
Visit our web site at: [www.cunninghamsecurity.com](http://www.cunninghamsecurity.com)

# MS-9050UD(E)

## Fire Alarm Control Panel with DACT

 **FIRE-LITE® Alarms**  
by Honeywell

**Addressable**

### General

The Fire•Lite MS-9050UD(E) is a Fire Alarm Control Panel (FACP) and Digital Alarm Communicator/Transmitter (DACT) combined into one circuit board. This compact, intelligent addressable control panel supports up to 50 addressable devices of any type of detectors and modules. With an extensive list of powerful features, the MS-9050UD programs just like Fire•Lite's larger products, yet fits into applications previously served only by conventional panels.

The MS-9050UD's integral DACT transmits system status (alarms, troubles, AC loss, etc.) to a Central Station via the public switched telephone network. It also allows remote and local programming of the control panel using the PK-CD Upload/Download utility. In addition, the control panel may be programmed or interrogated off-site via the public switched telephone network. Any personal computer with Windows™ 95 or greater, and compatible modem with a speed of 14.4 kbps or faster and Fire•Lite Upload/Download software kit PK-CD, may serve as a Service Terminal. This allows download of the entire program or upload of the entire program, history file, walk-test data, current status and system voltages.

The power supply and all electronics are contained on a single circuit board supported on a new quick install chassis and housed in a metal cabinet. Available accessories include local and remote upload/download software, remote annunciators, and reverse polarity/city box transmitter. (4XTMF)

New options include a UL listed printer, PRN-6F and the new IPDACT Internet Monitoring module. The FireWatch Series internet monitoring modules IPDACT-2 and IPDACT-2UD permit monitoring of alarm signals over the Internet, saving the monthly cost of two telephone lines. Although not required, the secondary telephone line may be retained providing backup communication over the public switched telephone line.

**NOTE:** Unless otherwise specified, the term MS-9050UD is used in this data sheet to refer to both the MS-9050UD and the MS-9050UDE FACPs. For MS-9050UDC, refer to DF-60445.

### Features

- Listed to UL Standard 864, 9th edition.
- Auto-program (learn mode) reduces installation time. Reports two devices set to the same address.
- On-board DACT.
- Two independently programmable Style Z (Class A) or Style Y (Class B) NAC circuits.
- Selectable strobe synchronization for System Sensor, Wheelock, and Gentex devices.
- Remote Acknowledge, Silence, Reset and Drill via addressable monitor modules.
- Two programmable relays and one fixed trouble relay.
- Built-in Programmer.
- Telephone Line Active LEDs.
- EIA-232 PC interface.
- Integral 80-character LCD display with backlighting.
- Real-time clock/calendar with automatic daylight savings control.
- History file with 500 event capacity.
- Automatic detector sensitivity testing (NFPA 72 compliant).
- Automatic device type-code verification.

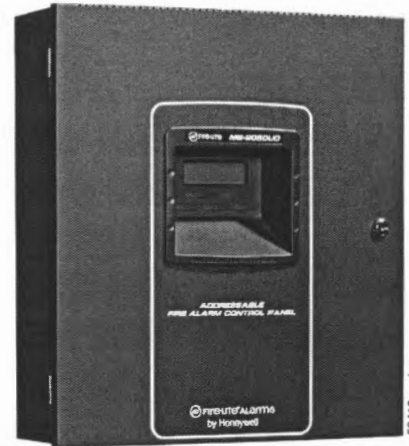

- Point trouble identification.
- Waterflow selection per module point.
- Alarm verification selection per detector point.
- Maintenance alert warns when smoke detector dust accumulation is excessive.
- One-person audible or silent walk test with walk-test log and printout.
- System alarm verification selection per detector point.
- PAS (Positive Alarm Sequence) and Pre-signal per point (NFPA 72 compliant).
- Up to eight ANN-BUS annunciators
- Remote Acknowledge, Alarm Silence, Reset and Drill via addressable modules or remote annunciator.
- Upload/Download (local or remote) of program and data via integral DACT.

### SLC COMMUNICATION LOOP

- Single addressable SLC loop which meets NFPA Style 4, 6 and 7 requirements.
- 50 addressable device capacity (any combination of addressable detectors and modules).
- Compatible with Fire•Lite's addressable devices (refer to SLC Wiring Manual).

### NOTIFICATION APPLIANCE CIRCUITS (NACS)

- Two independently programmable output circuits. Circuits can be configured for the following outputs:
  - Style Y (Class B)
  - Style Z (Class A)
  - Door Holder Service (cannot be used for notification appliances)
  - Aux Power Source (cannot be used for notification appliances)
- Silence Inhibit and Autosilence timer options.
- Continuous, March Time, Temporal or California code for main circuit board NACs with two-stage capability.
- Selectable strobe synchronization per NAC.
- 2.5 A total power for NACs.

**NOTE:** Maximum or total 24VDC system power shared between all NAC circuits and the ANN-BUS is 2.7 A.

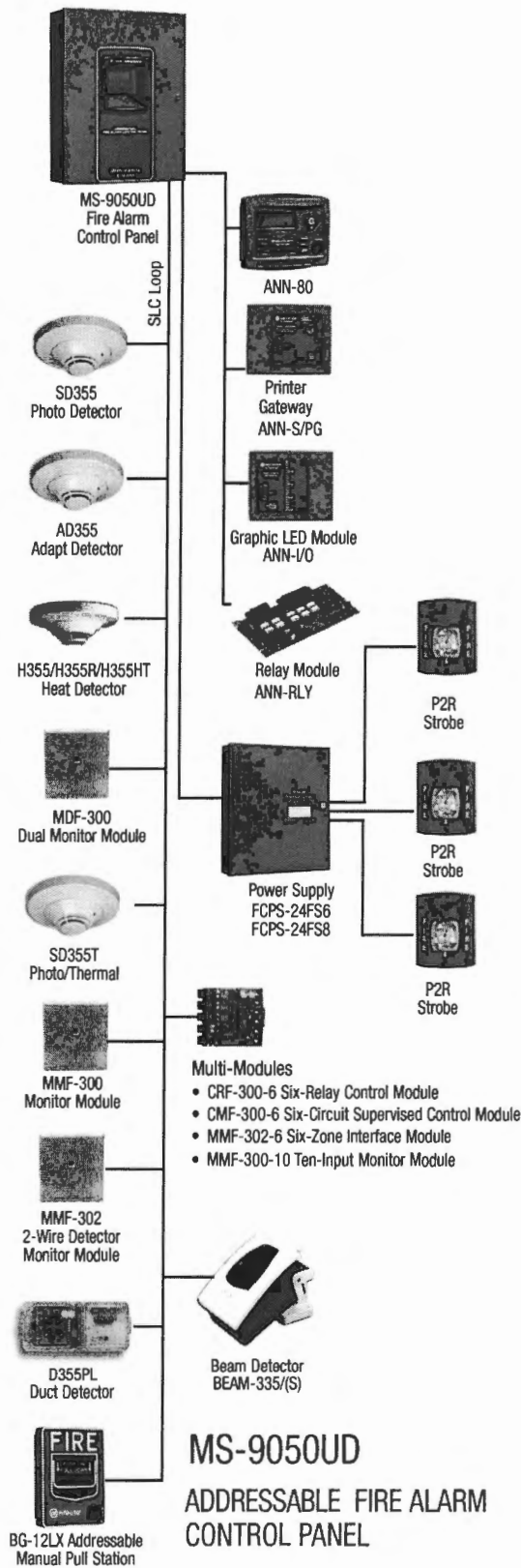

## PROGRAMMING AND SOFTWARE

- Autoprogram (learn mode) reduces installation time.
- Custom English labels (per point) may be manually entered or selected from an internal library file.
- Two programmable Form-C relay outputs.
- 20 software zones.
- Continuous fire protection during online programming at the front panel.
- Program Check automatically catches common errors not linked to any zone or input point.
- **OFFLINE PROGRAMMING:** Create the entire program in your office using a Windows®-based software package (order programming kit PK-CD, containing PK-Plus, separately). Upload/download system programming locally.

## User interface

### LED INDICATORS

- AC Power (green)
- Fire Alarm (red)
- Supervisory (yellow)
- Trouble (yellow)
- Alarm Silenced signals (yellow)

### KEYPAD

- 16 key alpha-numeric pad
- Acknowledge/Step
- Alarm Silenced
- Drill (Manual Evacuate)
- Reset (lamp test)

## Product Line Information

**MS-9050UD(E):** Combination DACT/Fire Alarm Control Panel with one SLC loop. Includes main circuit board with display, chassis with transformer, backbox with door, plastic bag containing screws, cables, key, etc., manual. (For MS-9050UDC, refer to DF-60445.)

**PK-CD:** Contains PK-Plus programming software for Windows®-based PC computer (cable not included).

**DP-51050:** Optional dress panel for the MS-9050UD.

**TR-CE:** Optional trim ring for semi-flush mounting.

**BB-2F:** Optional cabinet for one or two modules.

**BB-6F:** Optional cabinet for up to six modules mounted on CHS-6 chassis.

**BB-26:** Battery backbox, holds up to two 25 AH batteries and CHG-75.

**BB-55F:** Battery box, houses two 55 AH batteries

**CHS-6:** Chassis, mounts up to six multi-modules in a BB-6F cabinet.

**CHG-75:** Battery charger for lead-acid batteries with a rating of 25 to 75 AH.

**CHG-120F:** Remote battery charging system for lead-acid batteries with a rating of 55 to 120 AH. Requires additional BB-55F for mounting.

**BAT Series:** Batteries, see data sheet DF-52397.

**PRT/PK-CABLE:** Cable printer/personal computer interface cable.

**PRN-6F:** UL listed compatible event printer. Uses tractor-fed paper.

**IPDACT, IPDACT-2/2UD Internet Monitoring Module:** Mounts in bottom of enclosure with optional mounting kit (PN IPBRKT). Connects to primary and secondary DACT telephone output ports for internet communications over customer provided ether-



net internet connection. Requires compatible Teldat Visoralarm Central Station Receiver. Can use DHCP or static IP. (See *data sheet df-52424* for more information.)

**IPBRKT:** Mounting kit for IPDACT-2/2UD in common enclosure.

**IPSPLT:** Y-adaptor option allows connection of both panel dialer outputs to one IPDACT-2/2UD cable input.

**AC-TRMBLK:** AC Terminal Block mounts to a metal bracket, in turn, mounts to the FACP chassis. Use AC-TRMBLK when wire nuts are not allowed for AC connections to the transformer.

### OPTIONAL MODULES

**4XTMF Reverse Polarity Transmitter Module:** Provides a supervised output for local energy municipal box transmitter, alarm and trouble. Includes a disable switch and disable trouble LED.

**ANN-SEC:** Optional secondary ANN-BUS interface module. *Note: Used only with firmware 3.0 or higher.*

### COMPATIBLE ANNUNCIATORS

**ANN-80(-W):** Remote LCD annunciator mimics the information displayed on the FACP LCD display. Recommended wire type is un-shielded. (Basic model is red; order -W version for white; see DF-52417.)

**ANN-I/O:** LED Driver Module provides connections to a user supplied graphic annunciator. (See DF-52430.)

**ANN-LED:** Annunciator Module provides three LEDs for each zone: Alarm, Trouble, and Supervisory. Ships with red enclosure. (See DF-60241.)

**ANN-RLED:** Provides alarm (red) indicators for up to 30 input zones or addressable points. (See DF-60241.)

**ANN-RLY:** Relay Module provides 10 programmable Form-C relays. Can be mounted inside the cabinet. (See DF-52431.)

**ANN-S/PG:** Serial/Parallel Printer Gateway module provides a connection for a serial or parallel printer. (See DF-52429.)

### ADDRESSABLE DEVICES

*All feature a polling LED and rotary switches for addressing.*

**CP355:** Addressable low-profile ionization smoke detector.

**SD355:** Addressable low-profile photoelectric smoke detector.

**SD355T:** Addressable low-profile photoelectric smoke detector with thermal sensor.

**SD355R:** Remote test capable addressable photoelectric smoke detector for use with DNR(W) duct detector housing.

**H355:** Fast-response, low-profile heat detector.

**H355R:** Fast-response, low-profile heat detector with rate-of-rise option.

**H355HT:** Fast-response, low-profile heat detector that activates at 190°F/88°C.

**AD355:** Low-profile, intelligent, "Adapt" multi-sensor detector (B350LP base included).

**BEAM355:** Intelligent beam smoke detector.

**BEAM355S:** Intelligent beam smoke detector with integral sensitivity test.

**D355PL:** InnovairFlex low-flow non-relay duct-detector housing; includes SD355R.

**DNR:** InnovairFlex low-flow non-relay duct-detector housing. (Order SD355R separately.)

**DNRW:** InnovairFlex low-flow non-relay duct-detector housing, with NEMA-4 rating. Watertight. (Order SD355R separately.)

**MMF-300:** Addressable Monitor Module for one zone of normally-open dry-contact initiating devices. Mounts in standard

4.0" (10.16 cm.) box. Includes plastic cover plate and end-of-line resistor. Module may be configured for either a Style B (Class B) or Style D (Class A) IDC.

**MDF-300:** Dual Monitor Module. Same as MMF-300 except it provides two Style B (Class B) only IDCs.

**MMF-301:** Miniature version of MMF-300. Excludes LED and Style D option. Connects with wire pigtails. May mount in device backbox.

**MMF-302A:** Similar to MMF-300A. Addressable Monitor Module for one zone of conventional two-wire detectors. Requires resettable 24 VDC power. Refer to the *Device Compatibility Document* for listed compatible devices and quantity limitation.

**CMF-300:** Addressable Control Module for one Style Y/Z (Class B/A) zone of supervised polarized Notification Appliances. Mounts directly to a 4.0" (10.16 cm.) electrical box. Notification Appliance Circuit option requires external 24 VDC to power notification appliances.

**CRF-300:** Addressable relay module containing two isolated sets of Form-C contacts, which operate as a DPDT switch. Mounts directly to a 4.0" (10.16 cm.) box, surface mount using the SMB500.

**BG-12LX:** Addressable manual pull station with interface module mounted inside.

**I300:** This module isolates the SLC loop from short circuit conditions (required for Style 6 or 7 operation).

**SMB500:** Used to mount all modules except the MMF-301 and M301.

**MMF-300-10:** Ten-input monitor module. Mount one or two modules in a BB-2F cabinet (optional). Mount up to six modules on a CHS-6 chassis in a BB-6F cabinet.

**MMF-302-6:** Six-zone interface module. Mount one or two modules in a BB-2F cabinet (optional). Mount up to six modules on a CHS-6 chassis in a BB-6F cabinet.

**CMF-300-6:** Six-circuit supervised control module. Mount one or two modules in a BB-2F cabinet (optional). Mount up to six modules on a CHS-6 chassis in a BB-6F cabinet.

**CRF-300-6:** Six-relay control module (Form-C relays). Mount one or two modules in a BB-2F cabinet (optional). Mount up to six modules on a CHS-6 chassis in a BB-6F cabinet.

**NOTE:** For more information on Compatible Addressable Devices for use with the MS-9050UD, see the following data sheets (document numbers): AD355 (DF-52386), BG-12LX (DF-52013), CMF-300-6 (DF-52365), CRF-300-6 (DF-52374), CMF/CRF Series (DF-52130), CP355 (DF-52383), H355 Series (DF-52385), I300 (DF-52389), MMF-300 Series/MDF-300 (DF-52121), MMF-300-10 (DF-52347), MMF-302-6 (DF-52356), SD355/SD355T (DF-52384).

### ADDRESSABLE DEVICE ACCESSORIES

**End-of-Line Resistor Assembly (R-47K and R-3.9K):** The 47k ohm assembly supervises the MMF-300, MDF-300, MMF-301, and CMF-300 module circuits. The 3.9k ohm assembly supervises the MMF-302 module circuit. These resistors are included with each module.

**Power Supervision Relay:** Supervises the power to 4-wire smoke detectors and notification appliances.

### Wiring Requirements

While shielded wire is not required, it is recommended that all SLC wiring be twisted-pair to minimize the effects of electrical interference. Refer to the panel manual for wiring details.

# SYSTEM SPECIFICATIONS

## System Capacity

- Intelligent Signalling Line Circuits..... 1
- Addressable device capacity..... 50
- Programmable software zones..... 20
- Annunciators..... 8

## Electrical Specifications

**AC Power:** MS-9050UD 120 VAC, 60 Hz, 3.0 A. MS-9050UDE: 240 VAC, 50 Hz, 1.5 A. Wire size: minimum 14 AWG (2.00 mm<sup>2</sup>) with 600 V insulation. Nonpower-limited, supervised.

**Battery:** Two 12 V 18 AH lead-acid batteries. Battery Charger Capacity: 7-18 AH (MS-9050UD cabinet holds maximum of two 18 AH batteries.)

**Communication Loop:** Supervised and power-limited.

**Notification Appliance Circuits:** Terminal Block provides connections for two NACs, Style Y (Class B) or Style Z (Class A). Special Application power. Power-limited, supervised circuitry. Maximum signaling current per circuit: 2.5 A. End-of-Line Resistor: 4.7k ohm, ½ watt (P/N 71252 UL listed) for Style Y (Class B) NAC. Refer to the *Fire-Lite Device Compatibility Document* for listed compatible devices.

**Two Programmable Relays and One Fixed Trouble Relay:** Contact rating: 2.0 A @ 30 VDC (resistive), 0.5 A @ 30 VAC (resistive). Form-C relays, nonpower-limited, nonsupervised.

## Cabinet Specifications

**Door:** 19.26" (48.92 cm.) high x 16.82" (42.73 cm.) wide x 0.72" (1.82 cm.) deep. **Backbox:** 19.00" (48.26 cm.) high x 16.65" (42.29 cm.) wide x 5.25" (13.34 cm.) deep. **Trim Ring (TR-CE):** 22.00" (55.88 cm.) high x 19.65" (49.91 cm.) wide.

## Shipping Specifications

**Weight:** 26.9 lbs. (12.20 kg.) **Dimensions:** 20.00" (50.80 cm.) high x 22.5" (57.15 cm.) wide x 8.5" (21.59 cm.) deep.

## Temperature and Humidity Ranges

This system meets NFPA requirements for operation at 0 – 49°C/32 – 120°F and at a relative humidity 93% ± 2% RH (non-

condensing) at 32°C ± 2°C (90°F ± 3°F). However, the useful life of the system's standby batteries and the electronic components may be adversely affected by extreme temperature ranges and humidity. Therefore, it is recommended that this system and its peripherals be installed in an environment with a normal room temperature of 15 – 27°C/60 – 80°F.

## NFPA Standards

The MS-9050UD(E) complies with the following NFPA 72 Fire Alarm Systems requirements:

- **LOCAL** (Automatic, Manual, Waterflow and Sprinkler Supervisory).
- **AUXILIARY** (Automatic, Manual and Waterflow) (requires 4XTMF).
- **REMOTE STATION** (Automatic, Manual and Waterflow) (Where a DACT is not accepted, the alarm, trouble and supervisory relays may be connected to UL 864 listed transmitters. For reverse polarity signaling of alarm and trouble, 4XTMF is required.)
- **PROPRIETARY** (Automatic, Manual and Waterflow).
- **CENTRAL STATION** (Automatic, Manual and Waterflow, and Sprinkler Supervised).
- **OT, PSDN** (Other Technologies, Packet-switched Data Network)

## Agency Listings and Approvals

The listings and approvals below apply to the basic MS-9050UD(E) control panel. In some cases, certain modules may not be listed by certain approval agencies, or listing may be in process. Consult factory for latest listing status.

- **UL:** S624
- **FM approved**
- **CSFM:** 7165-0075:210
- **MEA:** 442-06-E

**NOTE:** See DF-60445 for ULC-listed model.

FireLite® Alarms® and System Sensor® are registered trademarks of Honeywell International Inc. Microsoft® and Windows® are registered trademarks of the Microsoft Corporation. ©2011 by Honeywell International Inc. All rights reserved. Unauthorized use of this document is strictly prohibited.



This document is not intended to be used for installation purposes.  
We try to keep our product information up-to-date and accurate.  
We cannot cover all specific applications or anticipate all requirements.  
All specifications are subject to change without notice.



Made in the U.S.A.

For more information, contact Fire-Lite Alarms. Phone: (800) 627-3473, FAX: (877) 699-4105.  
[www.firelite.com](http://www.firelite.com)

# BG-12LX

## Addressable Manual Pull Station



### Addressable Devices

#### General

The Fire-Lite BG-12LX is a state-of-the-art, dual-action (i.e., requires two motions to activate the station) pull station that includes an addressable interface (mounted inside) for Fire-Lite's addressable fire alarm control panels (FACPs). Because the BG-12LX is addressable, the control panel can display the exact location of the activated manual station. This leads fire personnel quickly to the location of the alarm.

#### Features

- Maintenance personnel can open station for inspection and address setting without causing an alarm condition.
- Built-in bicolor LED, which is visible through the handle of the station, flashes in normal operation and latches steady red when in alarm.
- Handle latches in down position and the word "ACTIVATED" appears to clearly indicate the station has been operated.
- Captive screw terminals wire-ready for easy connection to SLC loop (accepts up to 12 AWG/3.25 mm<sup>2</sup> wire).
- Can be surface mounted (with SB-10 or SB-I/O) or semi-flush mounted. Semi-flush mount to a standard single-gang, double-gang, or 4" (10.16 cm) square electrical box.
- Smooth dual-action design.
- Meets ADAAG controls and operating mechanisms guidelines (Section 4.1.3[13]); meets ADA requirement for 5 lb. maximum activation force.
- Highly visible.
- Attractive shape and textured finish.
- Key reset.
- Includes Braille text on station handle.
- Optional trim ring (BG12TR).
- Meets UL 38, Standard for Manually Actuated Signaling Boxes.

#### Construction

Shell, door, and handle are molded of durable polycarbonate material with a textured finish.

#### Specifications

- **Shipping Weight:** 9.6 oz. (272.15 g)
- **Normal operating voltage:** 24 VDC.
- **Maximum SLC loop voltage:** 28.0 VDC.
- **Maximum SLC loop current:** 230  $\mu$ A.
- **Temperature Range:** 32°F to 120°F (0°C to 49°C)
- **Relative Humidity:** 10% to 93% (noncondensing)
- **For use indoors in a dry location**

#### Installation

The BG-12LX will mount semi-flush into a single-gang, double-gang, or standard 4" (10.16 cm) square electrical outlet box, or will surface mount to the model SB-10 or SB-I/O surface backbox. If the BG-12LX is being semi-flush mounted, then the optional trim ring (BG12TR) may be used. The BG12TR is

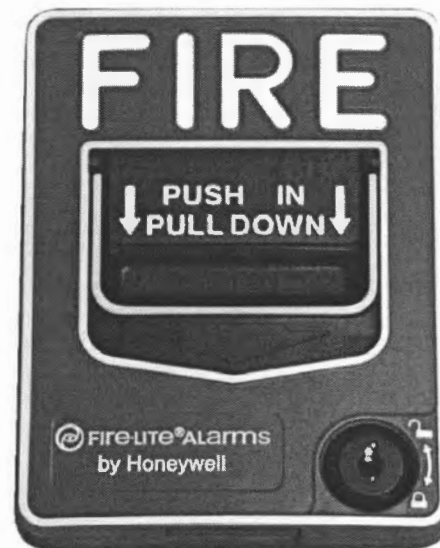

FU-PullStation.jpg

usually needed for semi-flush mounting with 4" (10.16 cm) or double-gang boxes (not with single-gang boxes).

#### Operation

Pushing in, then pulling down on the handle causes it to latch in the down/activated position. Once latched, the word "ACTIVATED" (in bright yellow) appears at the top of the handle, while a portion of the handle protrudes from the bottom of the station. To reset the station, simply unlock the station with the key and pull the door open. This action resets the handle; closing the door automatically resets the switch.

Each manual station, on command from the control panel, sends data to the panel representing the state of the manual switch. Two rotary decimal switches allow address settings (1 – 159 with Breakaway Tab removed for MS-9600 Series, 1 – 99 and MS-9200UDLS, 1 – 50 for MS-9050UD).

#### Architectural/Engineering Specifications

Manual Fire Alarm Stations shall be non-coded, with a key-operated reset lock in order that they may be tested, and so designed that after actual Emergency Operation, they cannot be restored to normal except by use of a key. An operated station shall automatically condition itself so as to be visually detected as activated. Manual stations shall be constructed of red-colored polycarbonate material with clearly visible operating instructions provided on the cover. The word FIRE shall appear on the front of the stations in white letters, 1.00 inches (2.54 cm) or larger. Stations shall be suitable for surface mounting on matching backbox SB-10 or SB-I/O; or semi-flush mounting on a standard single-gang, double-gang, or 4" (10.16 cm) square electrical box, and shall be installed within

the limits defined by the Americans with Disabilities Act (ADA) or per national/local requirements. Manual Stations shall be Underwriters Laboratories listed.

Manual stations shall connect with two wires to one of the control panel SLC loops. The manual station shall, on command from the control panel, send data to the panel representing the state of the manual switch. Manual stations shall provide address setting by use of rotary decimal switches.

### Product Line Information

**BG-12LX:** Dual-action addressable pull station. Includes key locking feature.

**SB-10:** Surface backbox; metal.

**SB-I/O:** Surface backbox; plastic.

**BG12TR:** Optional trim ring.

**17003:** Keys, set of two.

### Agency Listings and Approvals

In some cases, certain modules or applications may not be listed by certain approval agencies, or listing may be in process. Consult factory for latest listing status.

- **UL Listed:** S711
- **MEA:** 67-02-E
- **CSFM:** 7150-0075:0184
- **FDNY:**
- **FM Approved**

**Patented:** U.S. Patent No. D428,351; 6,380,846; 6,314,772; 6,632,108.

---

Fire-Lite is a registered trademark of Honeywell International Inc.  
©2010 by Honeywell International Inc. All rights reserved. Unauthorized use of this document is strictly prohibited.

---



This document is not intended to be used for installation purposes.  
We try to keep our product information up-to-date and accurate.  
We cannot cover all specific applications or anticipate all requirements.  
All specifications are subject to change without notice.



Made in the U.S. A.

For more information, contact Fire•Lite Alarms. Phone: (800) 627-3473, FAX: (877) 699-4105.  
[www.firelite.com](http://www.firelite.com)

# SD355(A), SD355T(A), SD355R(A)

df-52384:b • E-160

 **FIRE·LITE·ALARMS**  
by Honeywell

## Addressable Photoelectric Smoke Detectors

Addressable Devices

### General

The SD355(A) and SD355T(A) addressable, low-profile plug-in photoelectric detectors use a state-of-the-art photoelectric sensing chamber with communications to provide open area protection and are used exclusively with Fire·Lite's Addressable Fire Alarm Control Panels (FACPs). The SD355T(A) adds thermal sensors that will alarm at a fixed temperature of 135°F (57°C). Since these detectors are addressable, they will help emergency personnel quickly locate a fire during its early stages, potentially saving precious rescue time while also reducing property damage. Two LEDs on each sensor light to provide a local, visible sensor indication. Remote LED annunciator capability is available as an optional accessory (P/N RA100Z(A)). The SD355R is a remote test capable detector for use with D355PL or DNR(W) duct smoke detector housings.

### Features

#### SLC loop:

- Two-wire loop connection.
- Unit uses base for wiring.

#### Addressing:

- Addressable by device.
- Direct Decade entry of address: 01 – 99 with MS-9200 series, and 01 – 159 with MS-9600 series.

#### Architecture:

- Unique single-source, dual-chamber design to respond quickly and dependably to a broad range of fires.
- Sleek, low-profile design.
- Integral communications and built-in type identification.
- Built-in tamper-resistant feature.
- Removable cover and insect-resistant screen for simple field cleaning.

#### Operation:

- Withstands air velocities up to 4,000 feet-per-minute (20 m/sec.) without triggering a false alarm.
- Factory preset at 1.5% nominal sensitivity for panel alarm threshold level.
- Visible LED "blinks" when the unit is addressed (communicating with the fire panel) and latches on in alarm.

#### Mechanicals:

- Sealed against back pressure.
- Direct surface mounting or electrical box mounting.
- Mounts to: single-gang box, 3.5" (8.89 cm) or 4.0" (10.16 cm) octagonal box, or 4.0" (10.16 cm) square electrical box (using a plaster ring — included).

#### Other system features:

- Fully coated circuit boards and superior RF/transient protection.
- 94-V0 plastic flammability rating.
- Low standby current.

#### Options:

- Remote LED output connection (P/N RA100Z).



SD355 with B350LP base



SD355T with B350LP base

### Applications

Use photoelectric detectors in life-safety applications to provide a broad range of fire-sensing capability, especially where smoldering fires are anticipated. Ionization detectors are often better than photoelectric detectors at sensing fast, flaming fires.

### Construction

These detectors are constructed of off-white LEXAN®. SD355(T) plug-in, low-profile smoke detectors are designed to commercial standards and offer an attractive appearance.

### Installation

SD355(T) plug-in detectors use a detachable mounting base to simplify installation, service and maintenance. Mount base on box which is at least 1.5 inches (3.81 cm) deep. Suitable boxes include:

- 4.0" (10.16 cm) square box with plaster ring.
- 4.0" (10.16 cm) octagonal box.
- 3.5" (8.89 cm) octagonal box.
- Single-gang box.

**NOTE:** Because of the inherent supervision provided by the SLC loop, **end-of-line resistors** are not required. Wiring "T-taps" or branches are permitted for Style 4 (Class B) wiring. SD355R mounts in a D355PL or DNR(W) duct detector housing.

## Operation

Each SD355/T/R uses one of 99 possible addresses on the MS-9200 series and up to 318 (159 on each loop) on the MS-9600 series Signaling Line Circuit (SLC). It responds to regular polls from the system and reports its type and status.

The SD355/T/R addressable photoelectric sensor's unique unipolar chamber responds quickly and uniformly to a broad range of smoke conditions and can withstand wind gusts up to 4,000 feet-per-minute (20 m/sec.) without sending an alarm level signal. Because of its unipolar chamber, the SD355/T/R is approximately two times more responsive than most photoelectric sensors. This makes it a more stable detector.

## Detector Sensitivity Test

Each detector can have its sensitivity tested (required per NFPA 72, Chapter 14 on *Inspection, Testing and Maintenance*) when installed/connected to a MS-9200 series or MS-9600 series addressable fire alarm control panel. The results of the sensitivity test can be printed off the MS-9200 series or MS-9600 series for record keeping.

## Specification

**Voltage range:** 15 – 32 VDC (peak).

**Standby current:** 300 µA @ 24 VDC.

**LED current:** 6.5 mA @ 24 VDC (latched "ON").

**Air velocity:** 4,000 ft./min. (20 m/sec.) maximum.

**Diameter:** 6.1" (15.5 cm) installed in B350LP base.

**Height:** 2.1" (5.33 cm) installed in B350LP base.

**Weight:** 3.6 oz. (102 g).

**Operating temperature range:** for **SD355(A):** 0°C to 49°C (32°F to 120°F); for **SD355T(A):** 0°C to 38°C (32°F to 100°F).

**SD355R(A):** installed in a DNR(W) -20°C to 70°C (-4°F to 158°F).

**Temperature:** 0°C – 49°C (32°F – 120°F).

**Relative humidity:** 10% – 93%, non-condensing.

## Listings

Listings and approvals below apply to the SD355(A) and SD355T(A) detectors. In some cases, certain modules may not be listed by certain approval agencies, or listing may be in process. Consult factory for latest listing status.

- UL Listed, file S1059.
- ULC Listed, file S1059.
- CSFM approved: file 7272-0075:194.
- MEA approved: file 243-02-E.
- FM approved.

## Product Line Information

**NOTE:** "A" suffix indicates ULC-Listed model.

**SD355:** Addressable photoelectric detector; B350LP base included.

**SD355A:** Same as SD355 with ULC Listing (B350LPA base included).

**SD355T:** Same as SD355 but with **thermal** element; B350LP base included.

**SD355TA:** Same as SD355T with ULC Listing (B350LPA base included).

**SD355R:** Remote test capable addressable photoelectric detector for use with a D355PL or DNR(W) duct detector housing.

**B350LP(A):** Plug-in detector base. Dimensions: 6.1" (15.5 cm). Mounting: 4.0" (10.16 cm) square box with or without plaster ring, 4.0" (10.16 cm) octagonal box, 3.5" (8.89 cm) octagonal box, or single-gang box. All mounting boxes have a minimum depth of 1.5" (3.81 cm).

**B224RB(A):** Plug-in System Sensor **relay** detector base. **Diameter:** 6.2" (15.75 cm). **Mounting:** 4.0" (10.16 cm) square box with or without plaster ring, 4.0" (10.16 cm) octagonal box, or 3.5" (8.89 cm) octagonal box. All mounting boxes have a minimum depth of 1.5" (3.81 cm).

**B224BI(A):** Plug-in System Sensor **isolator** detector base. Maximum 25 devices between isolator bases (*see DF-52389*). **Diameter:** 6.2" (15.75 cm). **Mounting:** 4.0" (10.16 cm) square box with or without plaster ring, 4.0" (10.16 cm) octagonal box, or 3.5" (8.89 cm) octagonal box. All mounting boxes have a minimum depth of 1.5" (3.81 cm).

**B200SR:** Sounder base capable of producing temporal-3 or steady sound output.

### ACCESSORIES:

**RA100Z(A):** Remote LED annunciator. 3 – 32 VDC. Mounts to a U.S. single-gang electrical box. *For use with B501(A) and B350LP(A) bases only.*

**SMK400E:** Surface mounting kit provides for entry of surface wiring conduit. *For use with B501(A) base only.*

**RMK400:** Recessed mounting kit. *For use with B501(A) base only.*

**M02-04-00:** Test magnet.

**M02-09-00:** Test magnet with telescoping handle.

**XR2B:** Detector removal tool. Allows installation and/or removal of detector heads from bases in high ceiling applications.

**XP-4:** Extension pole for XR2B. Comes in three 5-foot (1.524 m) sections.

**T55-127-010:** Detector removal tool without pole.

**BCK-200B:** Black detector covers, box of 10 .

**WCK-200B:** White detector covers, box of 10 .

FlashScan® registered trademark of Honeywell International Inc. Bayblend® is a registered trademark of Bayer Corporation.

©2010 by Honeywell International Inc. All rights reserved. Unauthorized use of this document is strictly prohibited.



This document is not intended to be used for installation purposes.  
We try to keep our product information up-to-date and accurate.  
We cannot cover all specific applications or anticipate all requirements.  
All specifications are subject to change without notice.

For more information, contact FireLite Alarms. Phone: (800) 627-3473, FAX: (877) 699-4105.  
[www.firelite.com](http://www.firelite.com)



## Selectable-Output Horns, Strobes, and Horn Strobes

*SpectrAlert® Advance selectable-output horns, strobes, and horn strobes are rich with features guaranteed to cut installation times and maximize profits.*

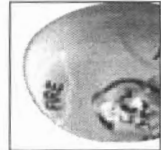
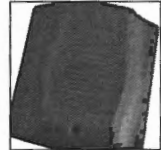

**SPECTRAlert**  
**ADVANCE**  
from System Sensor

### Features

- Plug-in design with minimal intrusion into the back box
- Tamper-resistant construction
- Automatic selection of 12- or 24-volt operation at 15 and 15/75 candela
- Field-selectable candela settings on wall and ceiling units: 15, 15/75, 30, 75, 95, 110, 115, 135, 150, 177, and 185
- Horn rated at 88+ dBA at 16 volts
- Rotary switch for horn tone and three volume selections
- Universal mounting plate for wall and ceiling units
- Mounting plate shorting spring checks wiring continuity before device installation
- Electrically compatible with existing SpectrAlert products
- Compatible with MDL sync module

**The SpectrAlert Advance series** offers the most versatile and easy-to-use line of horns, strobes, and horn strobes in the industry. With white and red plastic housings, wall and ceiling mounting options, and plain and FIRE-printed devices, SpectrAlert Advance can meet virtually any application requirement.

Like the entire SpectrAlert Advance product line, horns, strobes, and horn strobes include a variety of features that increase their application versatility while simplifying installation. All devices feature plug-in designs with minimal intrusion into the back box, which make installations fast and foolproof while virtually eliminating costly and time-consuming ground faults. Furthermore, a universal mounting plate with an onboard shorting spring tests wiring continuity before the device is installed, protecting devices from damage.

In addition, field-selectable candela settings, automatic selection of 12- or 24-volt operation, and a rotary switch for horn tones with three volume selections enables installers to easily adapt devices to suit a wide range of application requirements.

### Agency Listings



S4011 (chimes, horn strobes, horns)  
S5512 (strobes)



3023572



MEA452-05-E



7125-1653:186 (indoor strobes)  
7125-1653:188 (horn strobes,  
chime strobes)  
7135-1653:189 (horns, chimes)

# SpectrAlert Advance Specifications

## Architect/Engineer Specifications

### General

SpectrAlert Advance horns, strobes, and horn strobes shall mount to a standard 4 × 4 × 1½-inch back box, 4-inch octagon back box, or double-gang back box. Two-wire products shall also mount to a single-gang 2 × 4 × 1½-inch back box. A universal mounting plate shall be used for mounting ceiling and wall products. The notification appliance circuit wiring shall terminate at the universal mounting plate. Also, SpectrAlert Advance products, when used with the Sync-Circuit™ Module accessory, shall be powered from a non-coded notification appliance circuit output and shall operate on a nominal 12 or 24 volts. When used with the Sync-Circuit Module, 12-volt-rated notification appliance circuit outputs shall operate between 9 and 17.5 volts; 24-volt-rated notification appliance circuit outputs shall operate between 17 and 33 volts. Indoor SpectrAlert Advance products shall operate between 32 and 120 degrees Fahrenheit from a regulated DC or full-wave rectified unfiltered power supply. Strobes and horn strobes shall have field-selectable candela settings including 15, 15/75, 30, 75, 95, 110, 115, 135, 150, 177, and 185.

### Strobe

The strobe shall be a System Sensor SpectrAlert Advance Model \_\_\_\_\_ listed to UL 1971 and shall be approved for fire protective service. The strobe shall be wired as a primary-signaling notification appliance and comply with the Americans with Disabilities Act requirements for visible signaling appliances, flashing at 1 Hz over the strobe's entire operating voltage range. The strobe light shall consist of a xenon flash tube and associated lens/reflector system.

### Horn Strobe Combination

The horn strobe shall be a System Sensor SpectrAlert Advance Model \_\_\_\_\_ listed to UL 1971 and UL 464 and shall be approved for fire protective service. The horn strobe shall be wired as a primary-signaling notification appliance and comply with the Americans with Disabilities Act requirements for visible signaling appliances, flashing at 1 Hz over the strobe's entire operating voltage range. The strobe light shall consist of a xenon flash tube and associated lens/reflector system. The horn shall have three audibility options and an option to switch between a temporal three-pattern and a non-temporal (continuous) pattern. These options are set by a multiple position switch. On four-wire products, the strobe shall be powered independently of the sounder. The horn on horn strobe models shall operate on a coded or non-coded power supply.

### Synchronization Module

The module shall be a System Sensor Sync-Circuit model MDL listed to UL 464 and shall be approved for fire protective service. The module shall synchronize SpectrAlert strobes at 1 Hz and horns at temporal three. Also, while operating the strobes, the module shall silence the horns on horn strobe models over a single pair of wires. The module shall mount to a 4½ × 4½ × 2½-inch back box. The module shall also control two Style Y (class B) circuits or one Style Z (class A) circuit. The module shall synchronize multiple zones. Daisy chaining two or more synchronization modules together will synchronize all the zones they control. The module shall not operate on a coded power supply.

## Physical/Electrical Specifications

Standard Operating Temperature	32°F to 120°F (0°C to 49°C)
Humidity Range	10 to 93% non-condensing
Strobe Flash Rate	1 flash per second
Nominal Voltage	Regulated 12 DC/FWR or regulated 24 DC/FWR <sup>1</sup>
Operating Voltage Range <sup>2</sup>	8 to 17.5 V (12 V nominal) or 16 to 33 V (24 V nominal)
Input Terminal Wire Gauge	12 to 18 AWG
Ceiling-Mount Dimensions (including lens)	6.8" diameter × 2.5" high (173 mm diameter × 64 mm high)
Wall-Mount Dimensions (including lens)	5.6" L × 4.7" W × 2.5" D (142 mm L × 119 mm W × 64 mm D)
Horn Dimensions	5.6" L × 4.7" W × 1.3" D (142 mm L × 119 mm W × 33 mm D)
Wall-Mount Back Box Skirt Dimensions (BBS-2, BBSW-2)	5.9" L × 5.0" W × 2.2" D (151 mm L × 128 mm W × 56 mm D)
Ceiling-Mount Back Box Skirt Dimensions (BBSC-2, BBSCW-2)	7.1" diameter × 2.2" high (180 mm diameter × 57 mm high)
Wall-Mount Trim Ring Dimensions (sold as a 5 pack) (TR-HS, TRW-HS)	5.7" L × 4.8" W × 0.35" D (145 mm L × 122 mm W × 9 mm D)
Ceiling-Mount Trim Ring Dimensions (sold as a 5 pack) (TRC-HS, TRCW-HS)	6.9" diameter × 0.35" high (175 mm diameter × 9 mm high)

### Notes:

1. Full Wave Rectified (FWR) voltage is a non-regulated, time-varying power source that is used on some power supply and panel outputs.
2. P, S, PC, and SC products will operate at 12 V nominal only for 15 and 15/75 cd.



## UL Current Draw Data

### UL Max. Strobe Current Draw (mA RMS)

	Candela	8-17.5 Volts		16-33 Volts	
		DC	FWR	DC	FWR
Standard	15	123	128	66	71
Candela Range	15/75	142	148	77	81
	30	NA	NA	94	96
	75	NA	NA	158	153
	95	NA	NA	181	176
	110	NA	NA	202	195
	115	NA	NA	210	205
High Candela Range	135	NA	NA	228	207
	150	NA	NA	246	220
	177	NA	NA	281	251
	185	NA	NA	286	258

### UL Max. Horn Current Draw (mA RMS)

Sound Pattern	dB	8-17.5 Volts		16-33 Volts	
		DC	FWR	DC	FWR
Temporal	High	57	55	69	75
Temporal	Medium	44	49	58	69
Temporal	Low	38	44	44	48
Non-temporal	High	57	56	69	75
Non-temporal	Medium	42	50	60	69
Non-temporal	Low	41	44	50	50
Coded	High	57	55	69	75
Coded	Medium	44	51	56	69
Coded	Low	40	46	52	50

### UL Max. Current Draw (mA RMS), 2-Wire Horn Strobe, Standard Candela Range (15-115 cd)

DC Input	8-17.5 Volts		16-33 Volts		30	75	95	110	115
	15	15/75	15	15/75					
Temporal High	137	147	79	90	107	176	194	212	218
Temporal Medium	132	144	69	80	97	157	182	201	210
Temporal Low	132	143	66	77	93	154	179	198	207
Non-Temporal High	141	152	91	100	116	176	201	221	229
Non-Temporal Medium	133	145	75	85	102	163	187	207	216
Non-Temporal Low	131	144	68	79	96	156	182	201	210
<b>FWR Input</b>									
Temporal High	136	155	88	97	112	168	190	210	218
Temporal Medium	129	152	78	88	103	160	184	202	206
Temporal Low	129	151	76	86	101	160	184	194	201
Non-Temporal High	142	161	103	112	126	181	203	221	229
Non-Temporal Medium	134	155	85	95	110	166	189	208	216
Non-Temporal Low	132	154	80	90	105	161	184	202	211

### UL Max. Current Draw (mA RMS), 2-Wire Horn Strobe, High Candela Range (135-185 cd)

DC Input	16-33 Volts				FWR Input	16-33 Volts			
	135	150	177	185		135	150	177	185
Temporal High	245	259	290	297	Temporal High	215	231	258	265
Temporal Medium	235	253	288	297	Temporal Medium	209	224	250	258
Temporal Low	232	251	282	292	Temporal Low	207	221	248	256
Non-Temporal High	255	270	303	309	Non-Temporal High	233	248	275	281
Non-Temporal Medium	242	259	293	299	Non-Temporal Medium	219	232	262	267
Non-Temporal Low	238	254	291	295	Non-Temporal Low	214	229	256	262

## Horn Tones and Sound Output Data

### Horn and Horn Strobe Output (dBA)

Switch Position	Sound Pattern	dB	8-17.5 Volts		16-33 Volts		24-Volt Nominal			
			DC	FWR	DC	FWR	Reverberant		Anechoic	
1	Temporal	High	78	78	84	84	88	88	99	98
2	Temporal	Medium	74	74	80	80	86	86	96	96
3	Temporal	Low	71	73	76	76	83	80	94	89
4	Non-Temporal	High	82	82	88	88	93	92	100	100
5	Non-Temporal	Medium	78	78	85	85	90	90	98	98
6	Non-Temporal	Low	75	75	81	81	88	84	96	92
7†	Coded	High	82	82	88	88	93	92	101	101
8†	Coded	Medium	78	78	85	85	90	90	97	98
9†	Coded	Low	75	75	81	81	88	85	96	92

†Settings 7, 8, and 9 are not available on 2-wire horn strobe.



## Indoor Selectable-Output Horns, Strobes, and Horn Strobes for Wall Applications

*SpectrAlert® Advance audible visible notification products are rich with features guaranteed to cut installation times and maximize profits.*



**SPECTRAlert**  
ADVANCE  
from System Sensor

### Features

- Plug-in design with minimal intrusion into the back box
- Tamper-resistant construction
- Automatic selection of 12- or 24-volt operation at 15 and 15/75 candela
- Field-selectable candela settings on wall units: 15, 15/75, 30, 75, 95, 110, 115, 135, 150, 177, and 185
- Horn rated at 88+ dBA at 16 volts
- Rotary switch for horn tone and three volume selections
- Universal mounting plate for wall units
- Mounting plate shorting spring checks wiring continuity before device installation
- Electrically Compatible with legacy SpectrAlert devices
- Compatible with MDL sync module
- Listed for ceiling or wall mounting

**The SpectrAlert Advance series** offers the most versatile and easy-to-use line of horns, strobes, and horn strobes in the industry. With white and red plastic housings, wall and ceiling mounting options, and plain and FIRE-printed devices, SpectrAlert Advance can meet virtually any application requirement.

Like the entire SpectrAlert Advance product line, wall-mount horns, strobes, and horn strobes include a variety of features that increase their application versatility while simplifying installation. All devices feature plug-in designs with minimal intrusion into the back box, making installations fast and foolproof while virtually eliminating costly and time-consuming ground faults.

To further simplify installation and protect devices from construction damage, SpectrAlert Advance utilizes a universal mounting plate with an onboard shorting spring, so installers can test wiring continuity before the device is installed.

Installers can also easily adapt devices to suit a wide range of application requirements using field-selectable candela settings, automatic selection of 12- or 24-volt operation, and a rotary switch for horn tones with three volume selections.

### Agency Listings

SIGNALING



S4011 (chimes, horn strobes, horns)  
S5512 (strobes)



3023572

MEA  
approved

MEA452-05-E



7125-1653-186 (indoor strobes)  
7125-1653-188 (horn strobes,  
chime strobes)  
7135-1653-189 (horns, chimes)

# SpectrAlert Advance Specifications

## Architect/Engineer Specifications

### General

SpectrAlert Advance horns, strobes, and horn strobes shall mount to a standard 4 × 4 × 1½-inch back box, 4-inch octagon back box, or double-gang back box. Two-wire products shall also mount to a single-gang 2 × 4 × 17/8-inch back box. A universal mounting plate shall be used for mounting ceiling and wall products. The notification appliance circuit wiring shall terminate at the universal mounting plate. Also, SpectrAlert Advance products, when used with the Sync•Circuit™ Module accessory, shall be powered from a non-coded notification appliance circuit output and shall operate on a nominal 12 or 24 volts. When used with the Sync•Circuit Module, 12-volt-rated notification appliance circuit outputs shall operate between 8 and 17.5 volts; 24-volt-rated notification appliance circuit outputs shall operate between 16 and 33 volts. Indoor SpectrAlert Advance products shall operate between 32 and 120 degrees Fahrenheit from a regulated DC or full-wave rectified unfiltered power supply. Strobes and horn strobes shall have field-selectable candela settings including 15, 15/75, 30, 75, 95, 110, 115, 135, 150, 177, and 185.

### Strobe

The strobe shall be a System Sensor SpectrAlert Advance Model \_\_\_\_\_ listed to UL 1971 and shall be approved for fire protective service. The strobe shall be wired as a primary-signaling notification appliance and comply with the Americans with Disabilities Act requirements for visible signaling appliances, flashing at 1 Hz over the strobe's entire operating voltage range. The strobe light shall consist of a xenon flash tube and associated lens/reflector system.

### Horn Strobe Combination

The horn strobe shall be a System Sensor SpectrAlert Advance Model \_\_\_\_\_ listed to UL 1971 and UL 464 and shall be approved for fire protective service. The horn strobe shall be wired as a primary-signaling notification appliance and comply with the Americans with Disabilities Act requirements for visible signaling appliances, flashing at 1 Hz over the strobe's entire operating voltage range. The strobe light shall consist of a xenon flash tube and associated lens/reflector system. The horn shall have three audibility options and an option to switch between a temporal three pattern and a non-temporal (continuous) pattern. These options are set by a multiple position switch. On four-wire products, the strobe shall be powered independently of the sounder. The horn on horn strobe models shall operate on a coded or non-coded power supply.

### Synchronization Module

The module shall be a System Sensor Sync•Circuit model MDL listed to UL 464 and shall be approved for fire protective service. The module shall synchronize SpectrAlert strobes at 1 Hz and horns at temporal three. Also, while operating the strobes, the module shall silence the horns on horn strobe models over a single pair of wires. The module shall mount to a 411/16 × 411/16 × 21/8-inch back box. The module shall also control two Style Y (class B) circuits or one Style Z (class A) circuit. The module shall synchronize multiple zones. Daisy chaining two or more synchronization modules together will synchronize all the zones they control. The module shall not operate on a coded power supply.

## Physical/Electrical Specifications

<b>Standard Operating Temperature</b>	32°F to 120°F (0°C to 49°C)
<b>Humidity Range</b>	10 to 93% non-condensing
<b>Strobe Flash Rate</b>	1 flash per second
<b>Nominal Voltage</b>	Regulated 12 DC/FWR or regulated 24 DC/FWR <sup>1</sup>
<b>Operating Voltage Range<sup>2</sup></b>	8 to 17.5 V (12 V nominal) or 16 to 33 V (24 V nominal)
<b>Input Terminal Wire Gauge</b>	12 to 18 AWG
<b>Wall-Mount Dimensions (including lens)</b>	5.6" L × 4.7" W × 2.5" D (142 mm L × 119 mm W × 64 mm D)
<b>Horn Dimensions</b>	5.6" L × 4.7" W × 1.3" D (142 mm L × 119 mm W × 33 mm D)
<b>Wall-Mount Back Box Skirt Dimensions (BBS-2, BBSW-2)</b>	5.9" L × 5.0" W × 2.2" D (151 mm L × 128 mm W × 56 mm D)
<b>Wall-Mount Trim Ring Dimensions (sold as a 5 pack) (TR-HS, TRW-HS)</b>	5.7" L × 4.8" W × 0.35" D (145 mm L × 122 mm W × 9 mm D)

### Notes:

1. Full Wave Rectified (FWR) voltage is a non-regulated, time-varying power source that is used on some power supply and panel outputs.
2. P, S, PC, and SC products will operate at 12 V nominal only for 15 and 15/75 cd.

## UL Current Draw Data

### UL Max. Strobe Current Draw (mA RMS)

	Candela	8-17.5 Volts		16-33 Volts	
		DC	FWR	DC	FWR
<b>Standard Candela Range</b>	15	123	128	66	71
	15/75	142	148	77	81
	30	NA	NA	94	96
	75	NA	NA	158	153
	95	NA	NA	181	176
	110	NA	NA	202	195
	115	NA	NA	210	205
<b>High Candela Range</b>	135	NA	NA	228	207
	150	NA	NA	246	220
	177	NA	NA	281	251
	185	NA	NA	286	258

### UL Max. Horn Current Draw (mA RMS)

Sound Pattern	dB	8-17.5 Volts		16-33 Volts	
		DC	FWR	DC	FWR
Temporal	High	57	55	69	75
Temporal	Medium	44	49	58	69
Temporal	Low	38	44	44	48
Non-temporal	High	57	56	69	75
Non-temporal	Medium	42	50	60	69
Non-temporal	Low	41	44	50	50
Coded	High	57	55	69	75
Coded	Medium	44	51	56	69
Coded	Low	40	46	52	50

### UL Max. Current Draw (mA RMS), 2-Wire Horn Strobe, Standard Candela Range (15-115 cd)

DC Input	8-17.5 Volts		16-33 Volts		30	75	95	110	115
	15	15/75	15	15/75					
Temporal High	137	147	79	90	107	176	194	212	218
Temporal Medium	132	144	69	80	97	157	182	201	210
Temporal Low	132	143	66	77	93	154	179	198	207
Non-Temporal High	141	152	91	100	116	176	201	221	229
Non-Temporal Medium	133	145	75	85	102	163	187	207	216
Non-Temporal Low	131	144	68	79	96	156	182	201	210
<b>FWR Input</b>									
Temporal High	136	155	88	97	112	168	190	210	218
Temporal Medium	129	152	78	88	103	160	184	202	206
Temporal Low	129	151	76	86	101	160	184	194	201
Non-Temporal High	142	161	103	112	126	181	203	221	229
Non-Temporal Medium	134	155	85	95	110	166	189	208	216
Non-Temporal Low	132	154	80	90	105	161	184	202	211

### UL Max. Current Draw (mA RMS), 2-Wire Horn Strobe, High Candela Range (135-185 cd)

DC Input	16-33 Volts				FWR Input	16-33 Volts			
	135	150	177	185		135	150	177	185
Temporal High	245	259	290	297	Temporal High	215	231	258	265
Temporal Medium	235	253	288	297	Temporal Medium	209	224	250	258
Temporal Low	232	251	282	292	Temporal Low	207	221	248	256
Non-Temporal High	255	270	303	309	Non-Temporal High	233	248	275	281
Non-Temporal Medium	242	259	293	299	Non-Temporal Medium	219	232	262	267
Non-Temporal Low	238	254	291	295	Non-Temporal Low	214	229	256	262

## Horn Tones and Sound Output Data

### Horn and Horn Strobe Output (dBA)

Switch Position	Sound Pattern	dB	8-17.5 Volts		16-33 Volts		24-Volt Nominal			
			DC	FWR	DC	FWR	Reverberant		Anechoic	
			DC	FWR	DC	FWR	DC	FWR	DC	FWR
1	Temporal	High	78	78	84	84	88	88	99	98
2	Temporal	Medium	74	74	80	80	86	86	96	96
3	Temporal	Low	71	73	76	76	83	80	94	89
4	Non-Temporal	High	82	82	88	88	93	92	100	100
5	Non-Temporal	Medium	78	78	85	85	90	90	98	98
6	Non-Temporal	Low	75	75	81	81	88	84	96	92
7†	Coded	High	82	82	88	88	93	92	101	101
8†	Coded	Medium	78	78	85	85	90	90	97	98
9†	Coded	Low	75	75	81	81	88	85	96	92

†Settings 7, 8, and 9 are not available on 2-wire horn strobes.

## SpectrAlert Advance Dimensions

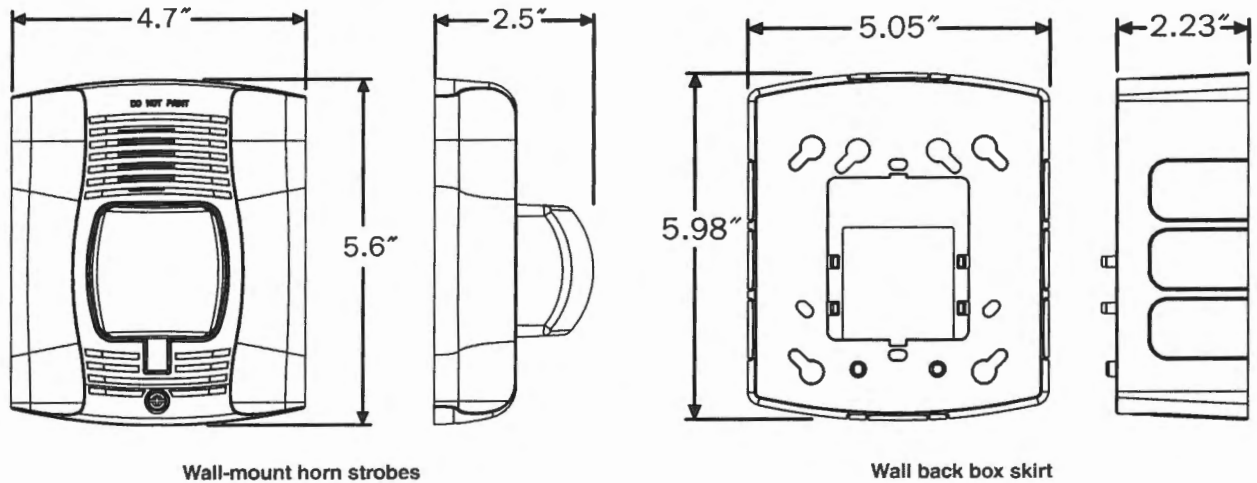

Wall-mount horn strobes

Wall back box skirt

## SpectrAlert Advance Ordering Information

Model	Description
<b>Wall Horn Strobes</b>	
P2R†	2-Wire Horn Strobe, Standard cd‡, Red
P2RH*	2-Wire Horn Strobe, High cd, Red
P2W*	2-Wire Horn Strobe, Standard cd, White
P2WH*	2-Wire Horn Strobe, High cd, White
P4R*	4-Wire Horn Strobe, Standard cd, Red
P4RH	4-Wire Horn Strobe, High cd, Red
P4W	4-Wire Horn Strobe, Standard cd, White
<b>Wall Strobes</b>	
SR*†	Strobe, Standard cd, Red
SRH*†	Strobe, High cd, Red
SW*	Strobe, Standard cd, White
SWH*	Strobe, High cd, White

Model	Description
<b>Horns</b>	
HR	Horn, Red
HW	Horn, White
<b>Accessories</b>	
BBS-2	Back Box Skirt, Wall, Red
BBSW-2	Back Box Skirt, Wall, White
TR-HS	Trim Ring, Wall, Red
TRW-HS	Trim Ring, Wall White

### Notes:

\* Add "-P" to model number for plain housing (no "FIRE" marking on cover), e.g., P2R-P.

† Add "-SP" to model number for "FUEGO" marking on cover, e.g., P2R-SP.

‡ "Standard cd" refers to strobes that include 15, 15/75, 30, 75, 95, 110, and 115 candela settings. "High cd" refers to strobes that include 135, 150, 177, and 185 candela settings.



3825 Ohio Avenue • St. Charles, IL 60174  
Phone: 800-SENSOR2 • Fax: 630-377-6495

©2012 System Sensor.  
Product specifications subject to change without notice. Visit [systemsensor.com](http://systemsensor.com)  
for current product information, including the latest version of this data sheet.  
AVDS00601 • 3/12

# MMF-300(A) Series, MDF-300(A)

## Addressable Monitor Modules



### Addressable Devices

#### General

Four different monitor modules are available for Fire•Lite's intelligent control panels to suit a variety of applications. Monitor modules are used to supervise a circuit of dry-contact input devices, such as conventional heat detectors and pull stations, or monitor and power a circuit of two-wire smoke detectors (MMF-302(A)).

**MMF-300(A)** is a standard-sized module (typically mounts to a 4" [10.16 cm] square box) that supervises either a Style D (Class A) or Style B (Class B) circuit of dry-contact input devices.

**MMF-301(A)** is a miniature monitor module a mere 1.3" (3.302 cm) H x 2.75" (6.985 cm) W x 0.5" (1.270 cm) D used to supervise a Style B (Class B) circuit of dry-contact input devices. Its compact design allows the MMF-301(A) to be mounted in a single-gang box behind the device it monitors.

**MMF-302(A)** is a standard-sized module used to monitor and supervise compatible two-wire, 24 volt, smoke detectors on a Style D (Class A) or Style B (Class B) circuit.

**MDF-300(A)** is a standard-sized dual monitor module used to monitor and supervise two independent two-wire Style B (Class B) dry-contact initiating device circuits (IDCs) at two separate, consecutive addresses in intelligent, two-wire systems.

LiteSpeed™ is a communication protocol developed by Fire•Lite Engineering that greatly enhances the speed of communication between analog intelligent devices. Intelligent devices communicate in a grouped fashion. If one of the devices within the group has new information, the panel CPU stops the group poll and concentrates on single points. The net effect is response speed greater than five times that of other designs.

#### MMF-300(A) Monitor Module

- Built-in type identification automatically identifies this device as a monitor module to the control panel.
- Powered directly by two-wire SLC loop. No additional power required.
- High noise (EMF/RFI) immunity.
- SEMS screws with clamping plates for ease of wiring.
- Direct-dial entry of address: 01 – 159 on MS-9600 series panels, 01 – 99 on other compatible systems.
- LED flashes during normal operation and latches on steady to indicate alarm.

The MMF-300(A) Monitor Module is intended for use in intelligent, two-wire systems, where the individual address of each module is selected using the built-in rotary switches. It provides either a two-wire or four-wire fault-tolerant Initiating Device Circuit (IDC) for normally-open-contact fire alarm and supervisory devices. The module has a panel-controlled LED indicator. The MMF-300(A) can be used to replace M300(A) modules in existing systems.

#### MMF-300(A) APPLICATIONS

Use to monitor a zone of four-wire smoke detectors, manual fire alarm pull stations, waterflow devices, or other normally-open dry-contact alarm activation devices. May also be used to monitor normally-open supervisory devices with special supervisory indication at the control panel. Monitored circuit

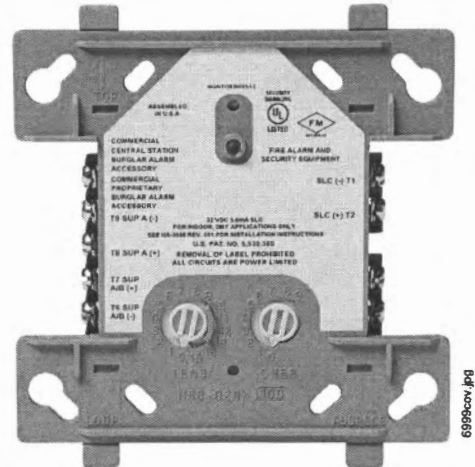

MMF-300(A) (Type H)

may be wired as an NFPA Style B (Class B) or Style D (Class A) Initiating Device Circuit. A 47K ohm End-of-Line Resistor (provided) terminates the Style B circuit. No resistor is required for supervision of the Style D circuit.

#### MMF-300(A) OPERATION

Each MMF-300(A) uses one of the available module addresses on an SLC loop. It responds to regular polls from the control panel and reports its type and the status (open/normal/short) of its Initiating Device Circuit (IDC). A flashing LED indicates that the module is in communication with the control panel. The LED latches steady on alarm (subject to current limitations on the loop).

#### MMF-300(A) SPECIFICATIONS

**Nominal operating voltage:** 15 to 32 VDC.

**Maximum current draw:** 5.0 mA (LED on).

**Average operating current:** 350  $\mu$ A (LED flashing), 1 communication every 5 seconds, 47k EOL.

**Maximum IDC wiring resistance:** 40 ohms.

**EOL resistance:** 47K ohms.

**Temperature range:** 32°F to 120°F (0°C to 49°C).

**Humidity range:** 10% to 93% noncondensing.

**Dimensions:** 4.5" (11.43 cm) high x 4" (10.16 cm) wide x 1.25" (3.175 cm) deep. Mounts to a 4" (10.16 cm) square x 2.125" (5.398 cm) deep box.

## MMF-301(A) Mini Monitor Module

- Built-in type identification automatically identifies this device as a monitor module to the panel.
- Powered directly by two-wire SLC loop. No additional power required.
- High noise (EMF/RFI) immunity.
- Tinned, stripped leads for ease of wiring.
- Direct-dial entry of address: 01 – 159 on MS-9600 series panels, 01 – 99 on other compatible systems

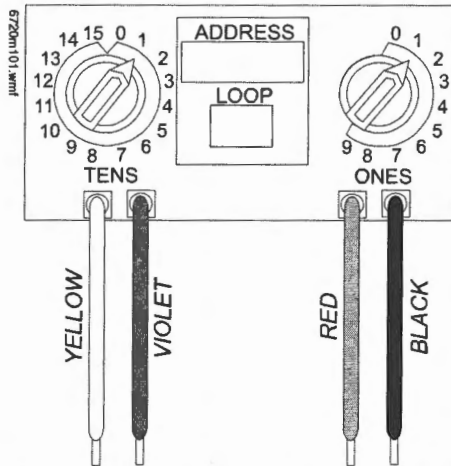

The MMF-301(A) Mini Monitor Module can be installed in a single-gang junction directly behind the monitored unit. Its small size and light weight allow it to be installed without rigid mounting. The MMF-301(A) is intended for use in intelligent, two-wire systems where the individual address of each module is selected using rotary switches. It provides a two-wire initiating device circuit for normally-open-contact fire alarm devices. The MMF-301(A) can be used to replace M301(A) modules in existing systems.

### MMF-301(A) APPLICATIONS

Use to monitor a single device or a zone of four-wire smoke detectors, manual fire alarm pull stations, waterflow devices, or other normally-open dry-contact devices. May also be used to monitor normally-open supervisory devices with special supervisory indication at the control panel. Monitored circuit/device is wired as an NFPA Style B (Class B) Initiating Device Circuit. A 47K ohm End-of-Line Resistor (provided) terminates the circuit.

### MMF-301(A) OPERATION

Each MMF-301(A) uses one of the available module addresses on an SLC loop. It responds to regular polls from the control panel and reports its type and the status (open/normal/short) of its Initiating Device Circuit (IDC).

### MMF-301(A) SPECIFICATIONS

Nominal operating voltage: 15 to 32 VDC.

**Average operating current:** 350  $\mu$ A, 1 communication every 5 seconds, 47k EOL; 600  $\mu$ A Max. (Communicating, IDC Shorted).

**Maximum IDC wiring resistance:** 40 ohms.

**Maximum IDC Voltage:** 11 Volts.

**Maximum IDC Current:** 400  $\mu$ A.

**EOL resistance:** 47K ohms.

**Temperature range:** 32°F to 120°F (0°C to 49°C).

**Humidity range:** 10% to 93% noncondensing.

**Dimensions:** 1.3" (3.302 cm) high x 2.75" (6.985 cm) wide x 0.65" (1.651 cm) deep.

**Wire length:** 6" (15.24 cm) minimum.

## MMF-302(A) Interface Module

- Supports compatible two-wire smoke detectors.
- Supervises IDC wiring and connection of external power source.
- High noise (EMF/RFI) immunity.
- SEMS screws with clamping plates for ease of wiring.
- Direct-dial entry of address: 01 – 159 on MS-9600 series panels, 01 – 99 on other compatible systems.
- LED flashes during normal operation.
- LED latches steady to indicate alarm on command from control panel.

The MMF-302(A) Interface Module is intended for use in intelligent, addressable systems, where the individual address of each module is selected using built-in rotary switches. This module allows intelligent panels to interface and monitor two-wire conventional smoke detectors. It transmits the status (normal, open, or alarm) of one full zone of conventional detectors back to the control panel. All two-wire detectors being monitored must be UL compatible with the module. The MMF-302(A) can be used to replace M302(A) modules in existing systems.

### MMF-302 (A) APPLICATIONS

Use the MMF-302(A) to monitor a zone of two-wire smoke detectors. The monitored circuit may be wired as an NFPA Style B (Class B) or Style D (Class A) Initiating Device Circuit. A 3.9 K ohm End-of-Line Resistor (provided) terminates the end of the Style B or D (class B or A) circuit (maximum IDC loop resistance is 25 ohms). Install ELR across terminals 8 and 9 for Style D application.

### MMF-302(A) OPERATION

Each MMF-302(A) uses one of the available module addresses on an SLC loop. It responds to regular polls from the control panel and reports its type and the status (open/normal/short) of its Initiating Device Circuit (IDC). A flashing LED indicates that the module is in communication with the control panel. The LED latches steady on alarm (subject to current limitations on the loop).

### MMF-302(A) SPECIFICATIONS

**Nominal operating voltage:** 15 to 32 VDC.

**Maximum current draw:** 5.1 mA (LED on).

**Maximum IDC wiring resistance:** 25 ohms.

**Average operating current:** 300  $\mu$ A, 1 communication and 1 LED flash every 5 seconds, 3.9k eol.

**EOL resistance:** 3.9K ohms.

**External supply voltage (between Terminals T3 and T4):** DC voltage: 24 volts power limited. Ripple voltage: 0.1 Vrms maximum. Current: 90 mA per module maximum.

**Temperature range:** 32°F to 120°F (0°C to 49°C).

**Humidity range:** 10% to 93% noncondensing.

**Dimensions:** 4.5" (11.43 cm) high x 4" (10.16 cm) wide x 1.25" (3.175 cm) deep. Mounts to a 4" (10.16 cm) square x 2.125" (5.398 cm) deep box.

## MDF-300(A) Dual Monitor Module

The MDF-300(A) Dual Monitor Module is intended for use in intelligent, two-wire systems. It provides two independent two-wire initiating device circuits (IDCs) at two separate, consecutive addresses. It is capable of monitoring normally open contact fire alarm and supervisory devices. The module has a single panel-controlled LED.

**NOTE:** The MDF-300(A) provides two Style B (Class B) IDC circuits ONLY. Style D (Class A) IDC circuits are NOT supported in any application.

### MDF-300(A) SPECIFICATIONS

**Normal operating voltage range:** 15 to 32 VDC.

**Maximum current draw:** 6.4 mA (LED on).

**Average operating current:** 750  $\mu$ A (LED flashing).

**Maximum IDC wiring resistance:** 1,500 ohms.

**Maximum IDC Voltage:** 11 Volts.

**Maximum IDC Current:** 240  $\mu$ A

**EOL resistance:** 47K ohms.

**Maximum SLC Wiring resistance:** 40 Ohms.

**Temperature range:** 32° to 120°F (0° to 49°C).

**Humidity range:** 10% to 93% (non-condensing).

**Dimensions:** 4.5" (11.43 cm) high x 4" (10.16 cm) wide x 2.125" (5.398 cm) deep.

### MDF-300(A) AUTOMATIC ADDRESSING

The MDF-300(A) automatically assigns itself to two addressable points, starting with the original address. For example, if the MDF-300(A) is set to address "26", then it will automatically assign itself to addresses "26" and "27".

**NOTE:** "Ones" addresses on the MDF-300(A) are 0, 2, 4, 6, or 8 only. Terminals 6 and 7 use the first address, and terminals 8 and 9 use the second address.



#### CAUTION:

Avoid duplicating addresses on the system.

## Installation

MMF-300(A), MMF-302(A), and MDF-300(A) modules mount directly to a standard 4" (10.16 cm) square, 2.125" (5.398 cm) deep, electrical box. They may also be mounted to the SMB500 surface-mount box. Mounting hardware and installation instructions are provided with each module. All wiring must conform to applicable local codes, ordinances, and regulations. These modules are intended for power-limited wiring only.

The MMF-301(A) module is intended to be wired and mounted without rigid connections inside a standard electrical box. All wiring must conform to applicable local codes, ordinances, and regulations.

## Agency Listings and Approvals

In some cases, certain modules may not be listed by certain approval agencies, or listing may be in process. Consult factory for latest listing status.

- **UL:** S2424
- **ULC:** S2424
- **FM Approved**
- **CSFM:** 7300-0075:0185
- **MEA:** 72-01-E

## Product Line Information

**NOTE:** "A" suffix indicates ULC-listed model.

**MMF-300(A):** Monitor module.

**MMF-301(A):** Monitor module, miniature.

**MMF-302(A):** Monitor module, two-wire detectors.

**MDF-300(A):** Monitor module, dual, two independent Class B circuits.

**SMB500:** Optional surface-mount backbox.

**NOTE:** See installation instructions and refer to the SLC Wiring Manual, PN 51309.

## Architects'/Engineers' Specifications

Specifications of these devices and all FireLite products are available from FireLite.



Fire-Lite® and LiteSpeed® are registered trademarks and FireWatch™ is a trademark of Honeywell International Inc.  
©2010 by Honeywell International Inc. All rights reserved. Unauthorized use of this document is strictly prohibited.

**ISO 9001**  
**CERTIFIED**  
ENGINEERING & MANUFACTURING  
QUALITY SYSTEMS

This document is not intended to be used for installation purposes.  
We try to keep our product information up-to-date and accurate.  
We cannot cover all specific applications or anticipate all requirements.  
All specifications are subject to change without notice.



Made in the U.S. A.

For more information, contact Fire•Lite Alarms. Phone: (800) 627-3473, FAX: (877) 699-4105.  
[www.firelite.com](http://www.firelite.com)

# TS300

## Dual Temperature Sensor



Honeywell's feature-rich TS300 was engineered to meet the demands of a wide range of applications. From florists and butchers to pet shops, computer centers and residences, the TS300 provides uncompromising performance. Unique features such as simultaneous use of local and remote temperature probes, programmable hysteresis and audible alarm with silence timeout, illustrate the sensor's flexibility in installation, programming and operation.

### FEATURES:

#### Flexibility:

The TS300 allows the end-user to independently program local and remote temperature probes in accordance with varying environmental requirements.

#### Programmable Hysteresis:

Temporary conditions often influence the gradual rise and fall of temperatures around the alarm point. Under such conditions, conventional sensors generate multiple alarms and restore messages. With the Programmable Hysteresis feature, an alarm is generated only the first time the temperature reaches the alarm point. As long as the temperature fluctuates within the "Hysteresis Range", no subsequent alarms will be transmitted until the environment has reached the predetermined restore temperature.

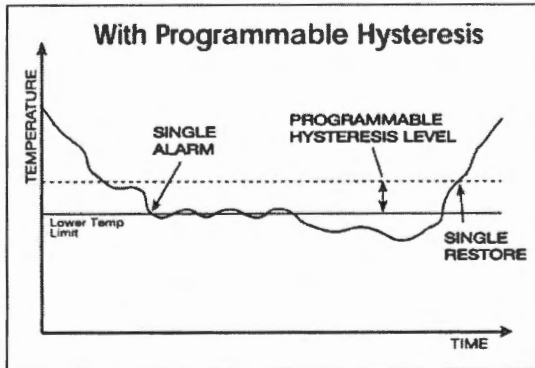
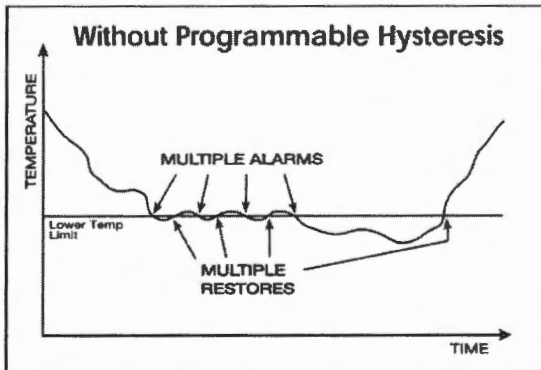

#### Versatility:

The TS300 is a dual temperature sensor that has the capacity to simultaneously monitor both local and remote temperature probes.

#### Audible Alarm with Silence Timeout:

The TS300 is equipped with an audible alarm which sounds once the temperature at an enabled sensor varies outside of its defined limits. The TS300 allows users to designate a "time-out" time. With the touch of a button, users may silence a sounding alarm for a period of time.

#### Programmable Alarm Delay:

Designed to reduce the occurrence of nuisance alarms during temporary conditions this feature allows the user to delay the sounding of the alarm for a designated period of time. Routine task, which may cause the temperature to rise above or fall below the programmed alarm point, may be completed without generating an alarm.

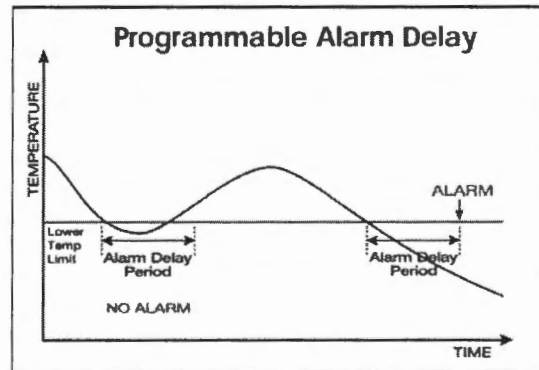

#### Alarm Memory:

Up to eight events are stored in memory. An alarm event is one where the relay output was activated.

# TS300

## Dual Temperature Sensor

### SPECIFICATIONS:

---

#### TS300

#### Dual Temperature Sensor

##### Temperature Range/Accuracy

Local Sensor

- 32°F to 140°F (0°C to 60°C)
- +/-3°F (+/-1.7°C)

Remote Probe

- -40°F to 140°F (-40°C to 60°C)
- +/-4°F (+/-2.2°C)

##### Hi and Low Limits

- Minimum span between
- 4°F (2.2°C)

##### Input Voltage

- 7 to 16VDC

##### Input Current

- 25 mA (max.)

##### Case Dimensions

- 4" x 2.6" x 0.9"
- (10.2 cm x 6.6 cm x 2.3 cm)

##### Alarm Delay

- 0-255 minutes in 1 minute increments

##### Alarm Output Type

- (2) Form A reed relays

##### Alarm Output Resistance

- 25 ohms maximum

##### Alarm Output Rating

- 50mA/30VDC maximum

##### Audible Alarm

- 4kHz, 75dB@10cm pulsed 750 mS on/off

##### Audible Alarm Silencing

- 0-255 minutes in one minute increments
- 

#### T280R

#### Remote Temperature Probe for use with the TS300

##### Description

- The Remote Probe is a sealed temperature sensor with 15 feet of two conductor, 24 AWG stranded cable.

##### Chemical Properties

- Non-corrosive Waterproof

##### Max. Cable Length

- 300 feet (The T280R may be extended from 15' up to 300' using shielded 24 AWG cable.)

##### Max. Compression Force Applied To Probe

- 10 lb. force

##### Max. Tensile Force Applied Between Probe and Cable

- 5 lb. force

### ORDERING:

<b>TS300</b>	Dual Temperature Sensor
<b>T280R</b>	Remote Temperature Probe