

N1 MASONRY PLUG DETAIL
N.T.S.

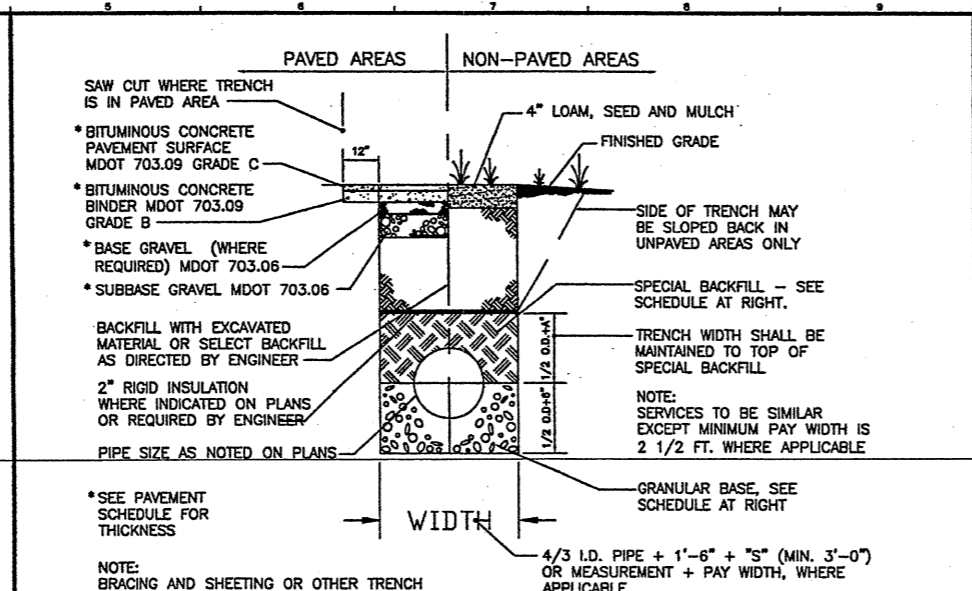

N10 NEW PVMT ADJACENT TO EXISTING PVMT
N.T.S.

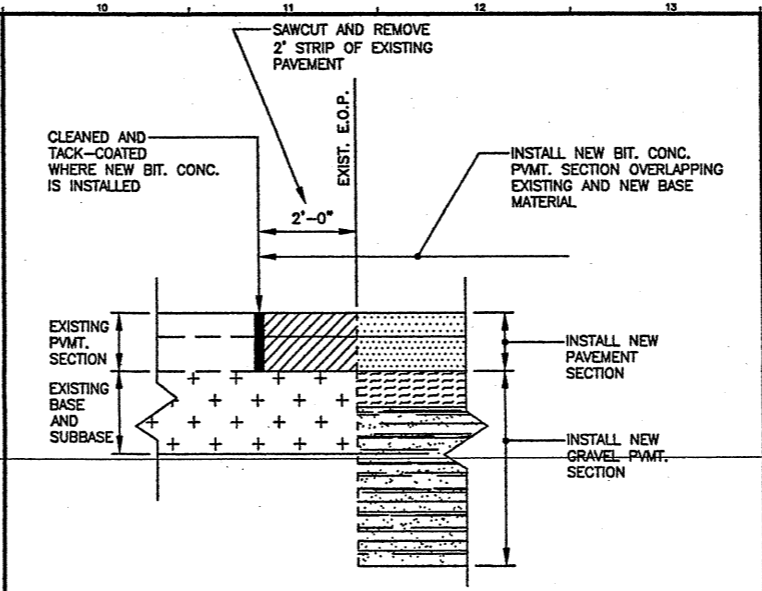

H1 TYPICAL UNDERDRAIN TRENCH SECTION
N.T.S.

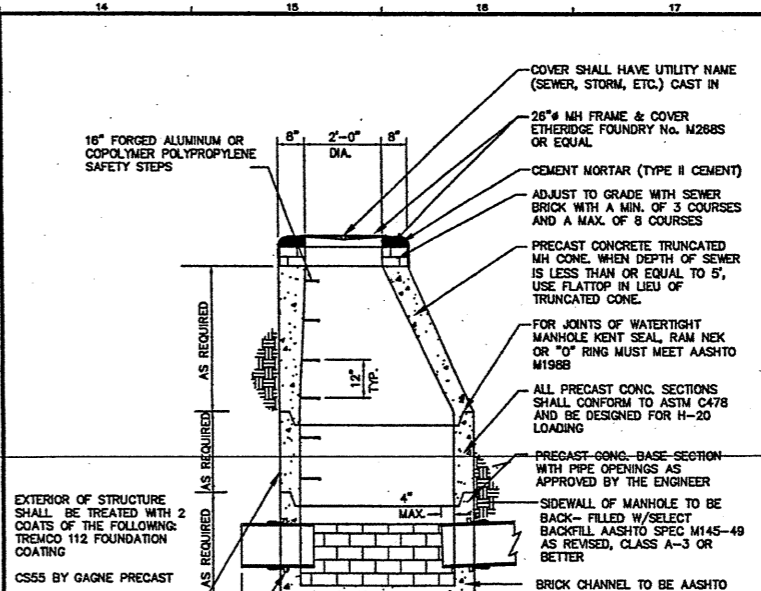

H5 TYPICAL SEWER AND STORM DRAIN TRENCH SECTION
N.T.S.

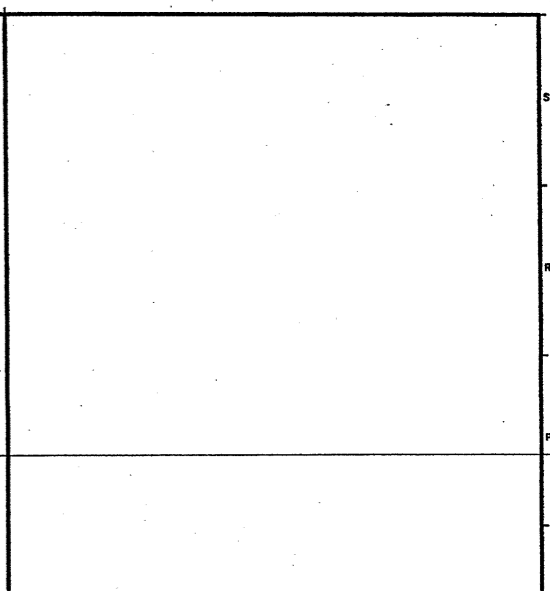

H10 BITUMINOUS PAVEMENT SECTION
N.T.S.

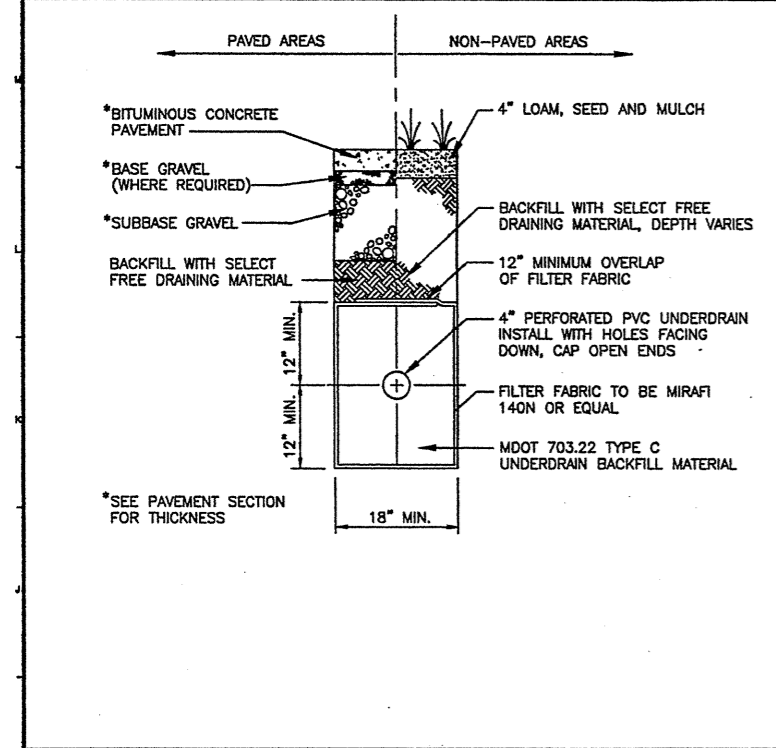

E1 GRANITE CURB DETAIL
N.T.S.

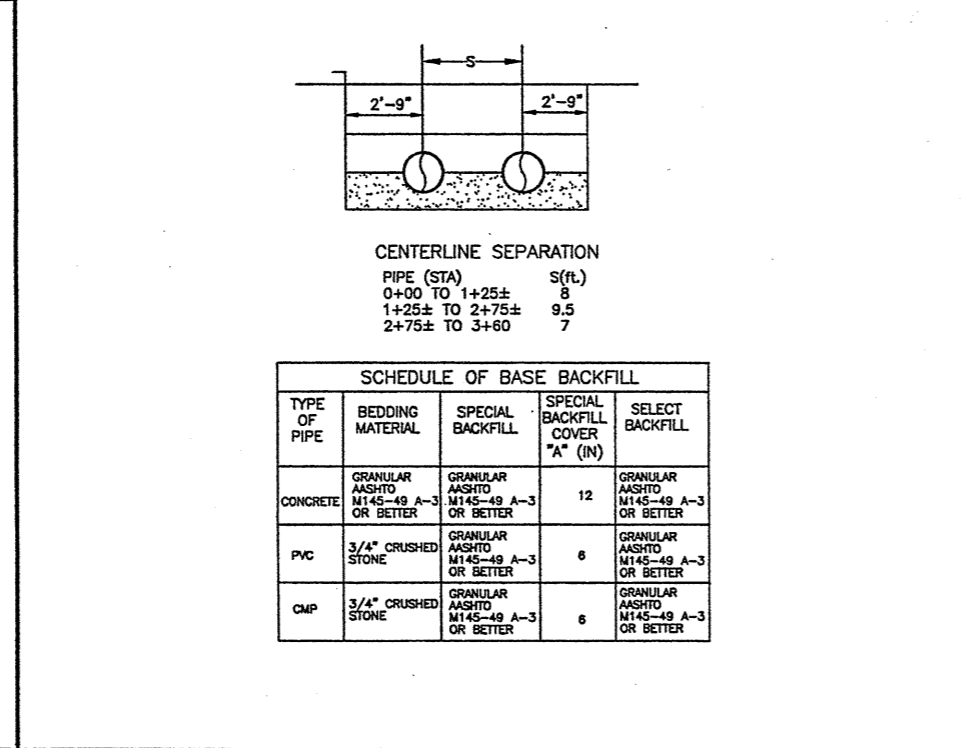

A5 SINGLE LEAF GATE DETAIL
N.T.S.

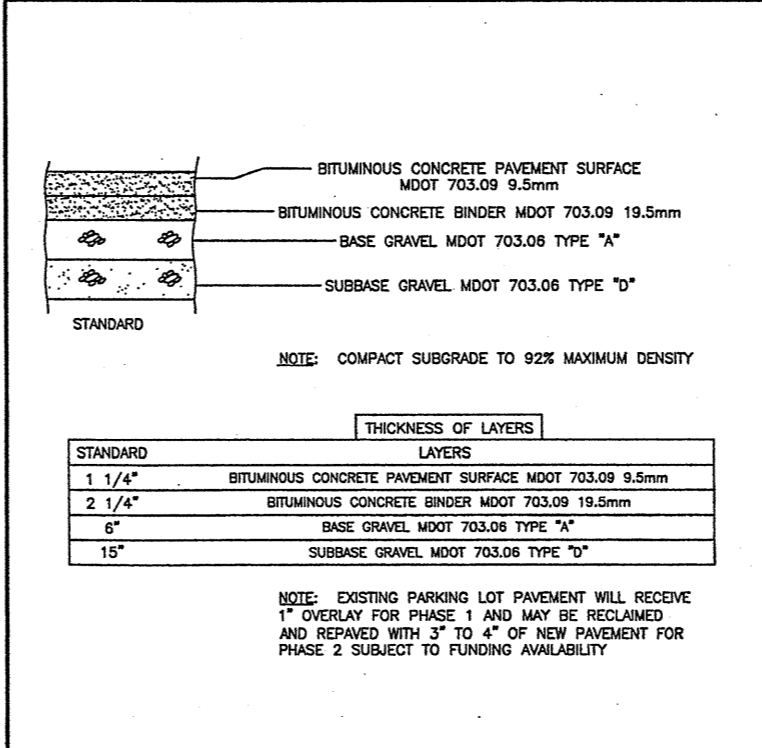

A10 SILTATION FENCE DETAIL
N.T.S.

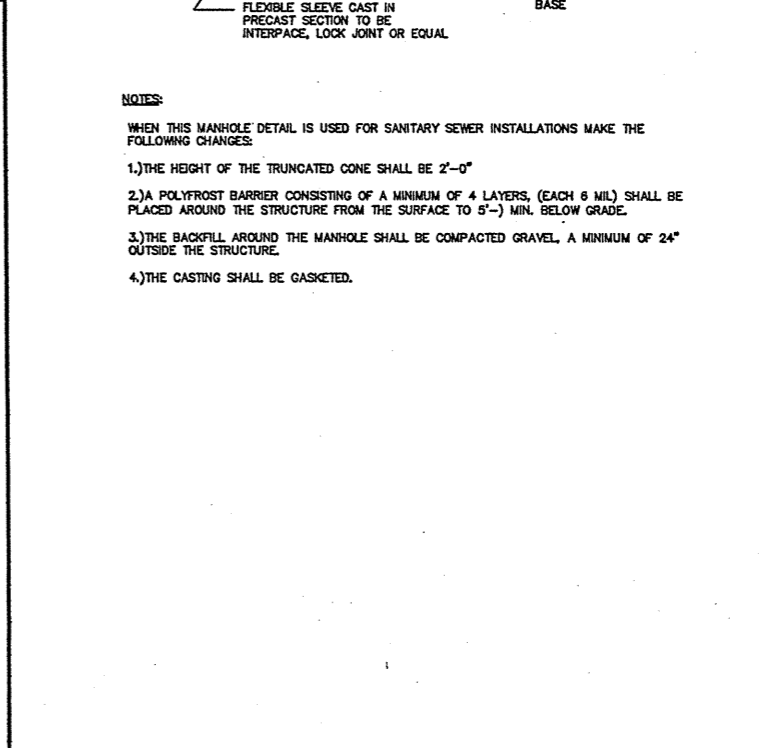

A14 PEDESTRIAN RAMP
N.T.S.

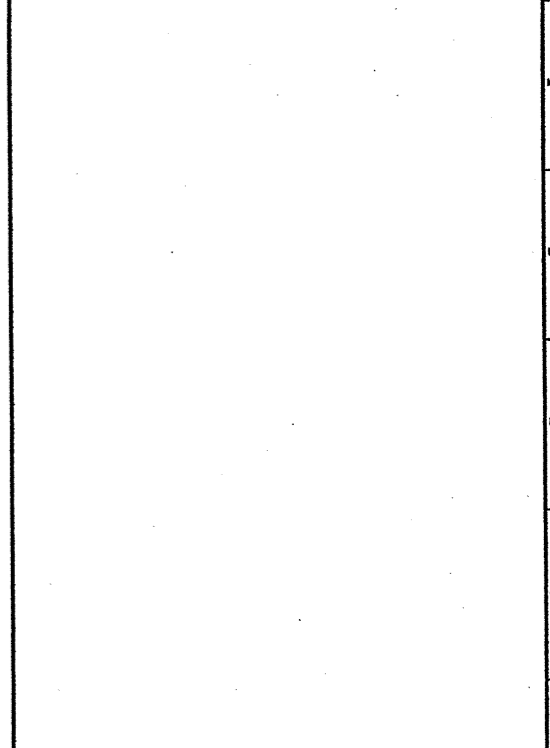

H14 4'-0\"/> PRECAST SAN. SEWER MANHOLE
N.T.S.

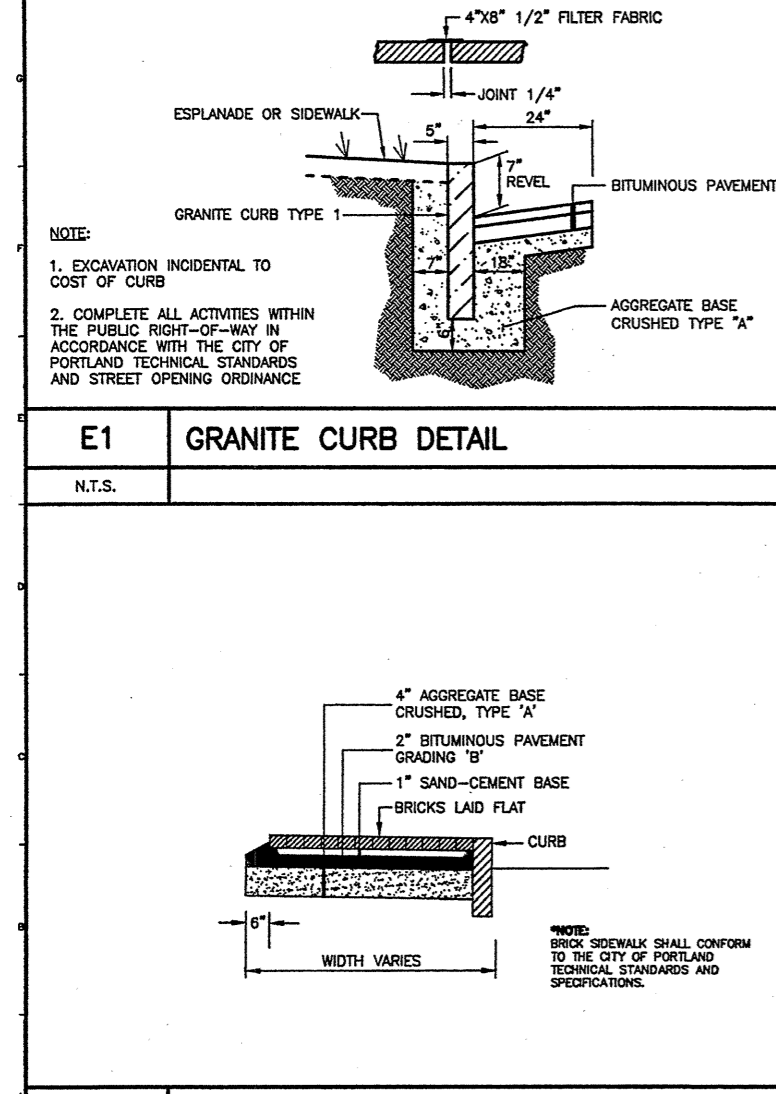

A1 BRICK WITH BITUMINOUS BASE SIDEWALK
N.T.S.

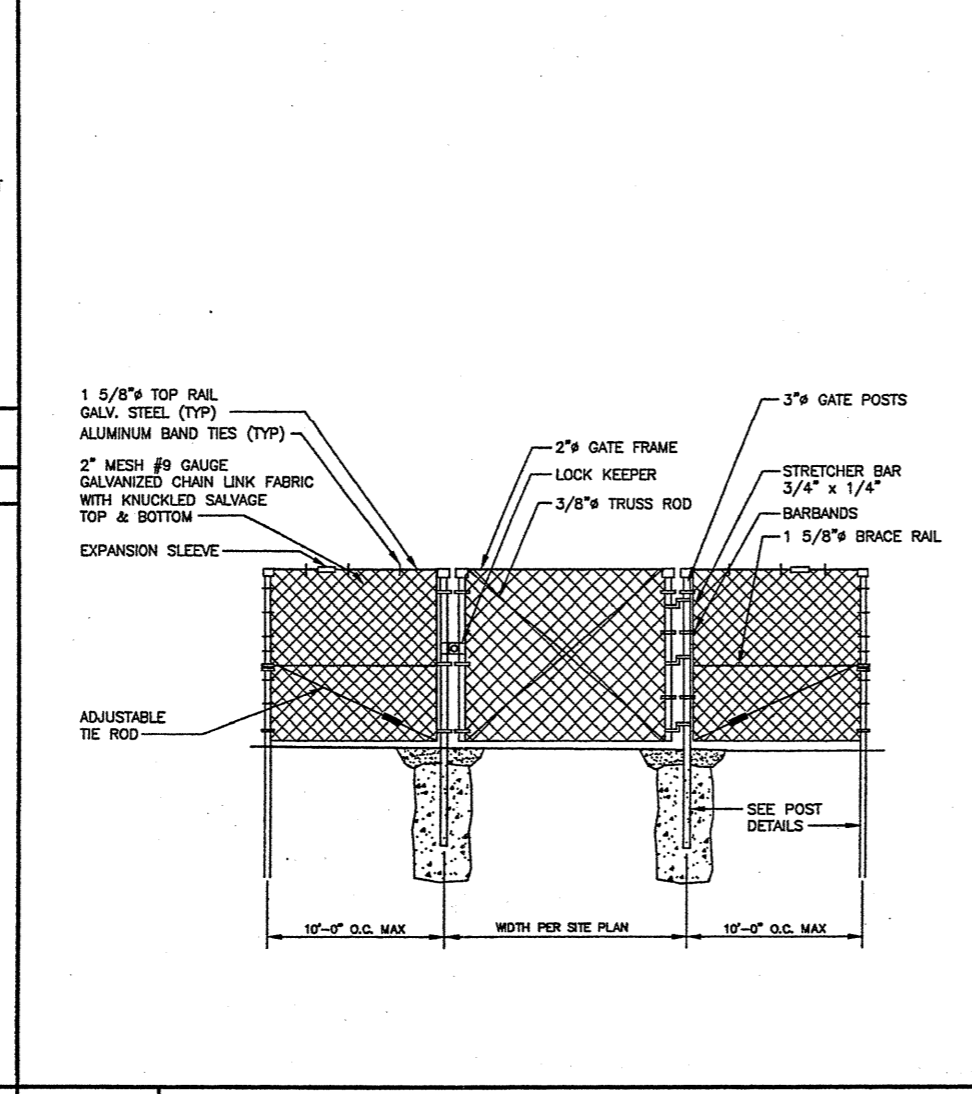

A5 SINGLE LEAF GATE DETAIL
N.T.S.

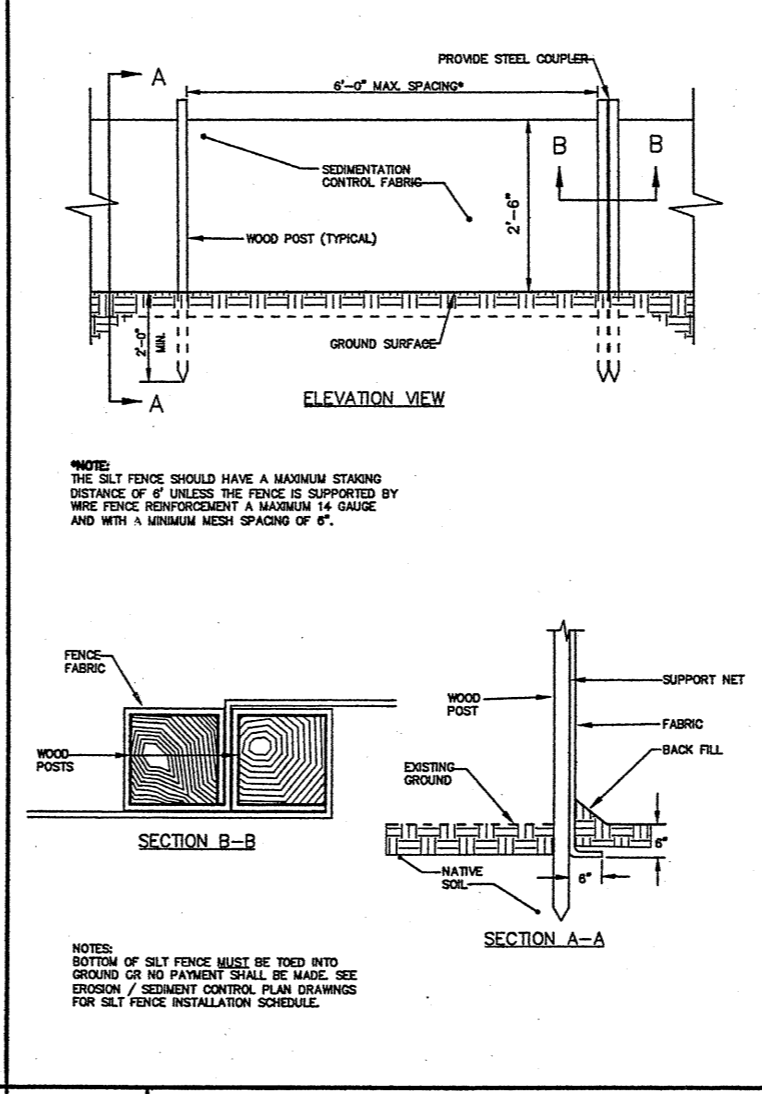

A10 SILTATION FENCE DETAIL
N.T.S.

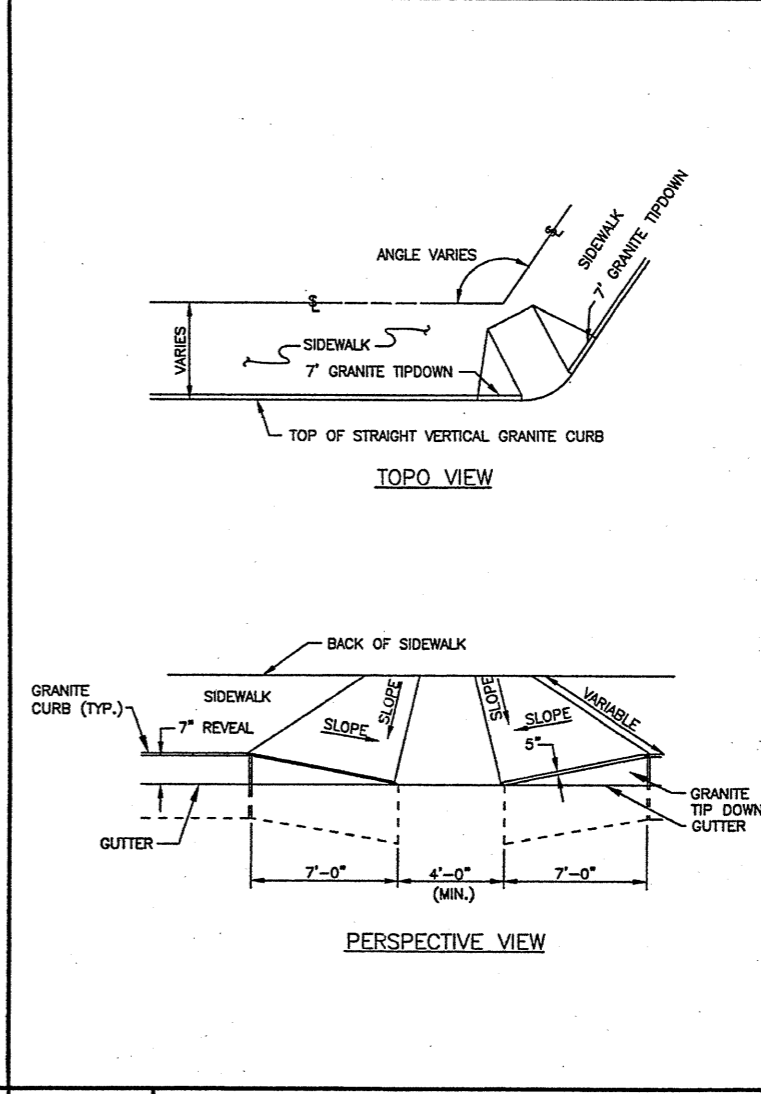

A14 PEDESTRIAN RAMP
N.T.S.

5	FINAL APPROVAL PLANS FOR CITY RECORDS	8.25.03
4	PHASE 1 CONSTRUCTION DOCUMENTS	8.12.03
3	FINAL SUBMISSION TO PORTLAND PLANNING AUTH.	7.30.03
2	DESIGN DEVELOPMENT SUBMISSION	6.13.03
1	SECOND WORKSHOP SUBMISSION TO CITY	6.10.03
REV.	DESCRIPTION	DATE

CURRENT ISSUE STATUS:

DH DeLUCA-HOFFMAN ASSOCIATES, INC.
778 MAIN STREET, SUITE 8
SOUTH PORTLAND, ME 04106
207.778.1121
WWW.DELUCAHOFFMAN.COM

SMRT ARCHITECTURE ENGINEERING PLANNING
SMRT
144 Fore Street, P.O. Box 618
Portland, Maine 04104
tel. (207) 772-2846
fax. (207) 772-1070

THE GULF OF MAINE RESEARCH INSTITUTE
PORTLAND, MAINE

SITE DETAILS

SHEET TITLE:	AS NOTED	DATE:
SCALE:	RML	GRAPHIC SCALE: 0" = 1"
PROJECT MANAGER:	CWW	
JOB CAP/DRAWN:	DWJ	SHEET No.
A/E OF RECORD:	CP501-03034	
SMRT CAD FILE:	03034-00/1984.1	
PROJECT No.	03034-00/1984.1	CP502