

N9 CA DROP (TYP.)
NOT TO SCALE

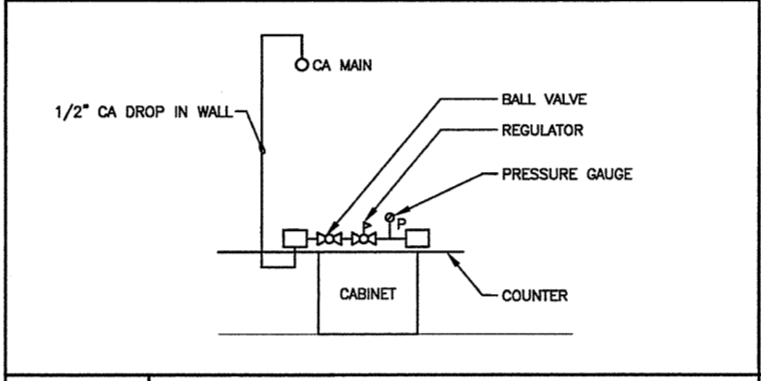

L9 LAB BENCH CA (TYP.)
NOT TO SCALE

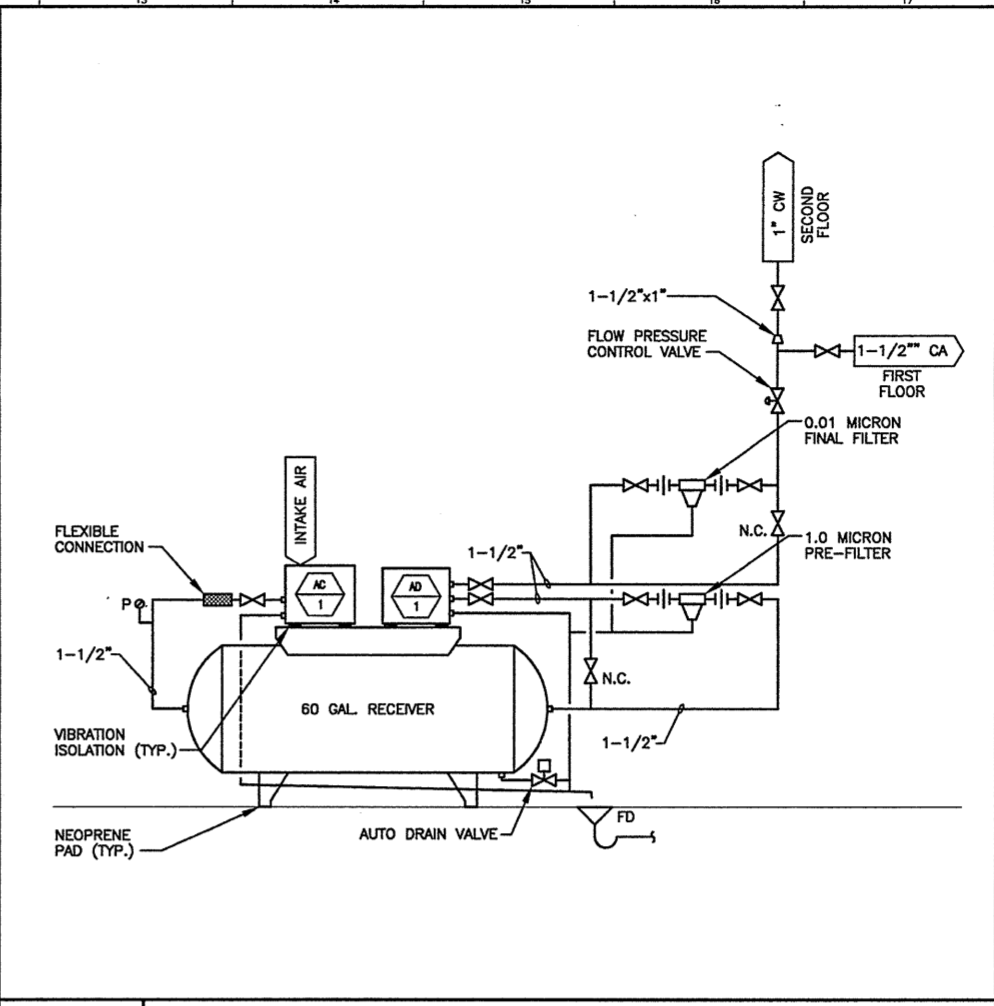

L13 COMPRESSED AIR SCHEMATIC
NOT TO SCALE

NOTE:
1. SEE SHEET M-001 FOR LEGEND AND ABBREVIATIONS.

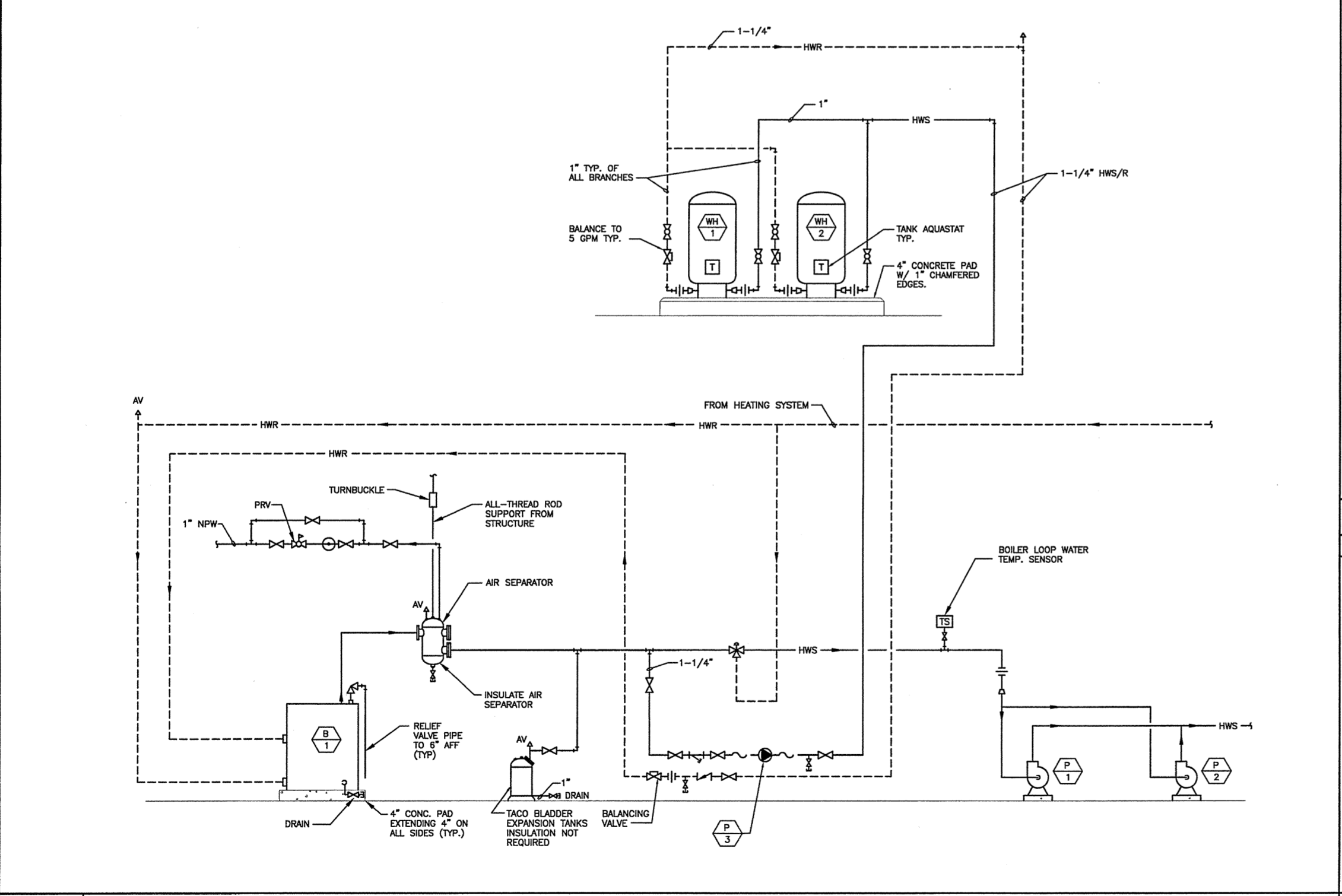

A1 HYDRONIC HEATING/DHW SYSTEM SCHEMATIC
NOT TO SCALE

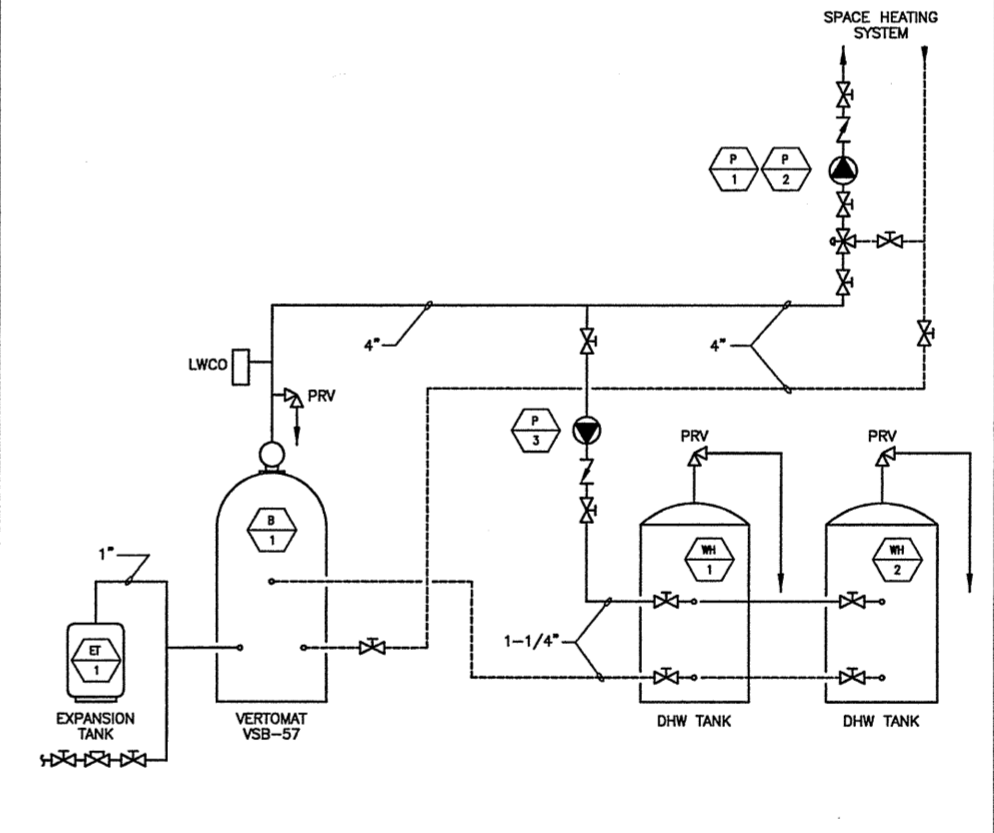

E13 PIPING DIAGRAM
NOT TO SCALE

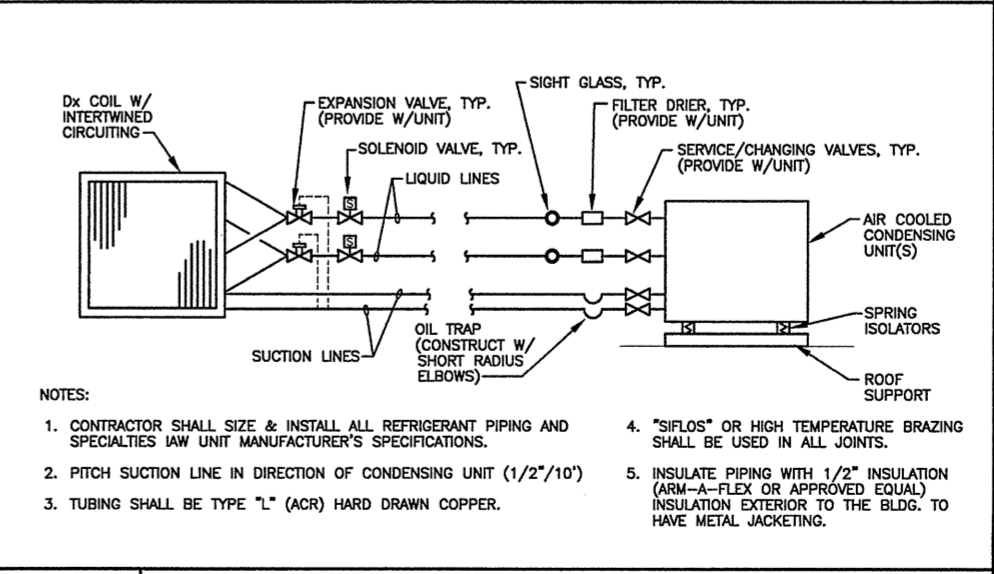

A13 REFRIGERANT PIPING SCHEMATIC
NOT TO SCALE

| REV. | DESCRIPTION | DATE |
|------|-------------------------|----------|
| 0 | ISSUED FOR CONSTRUCTION | 10-23-03 |

ISSUED FOR CONSTRUCTION
10-23-03

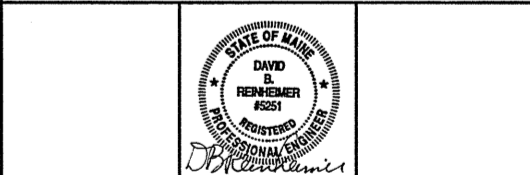

SMRT ARCHITECTURE ENGINEERING PLANNING
SMRT
144 Fore Street/P.O. Box 618
Portland, Maine 04104
Tel. (207) 772-3846
Fax. (207) 772-1070

THE GULF OF MAINE RESEARCH INSTITUTE
PORTLAND, MAINE

DETAILS

| | | | |
|------------------|--------------|----------------|----------|
| SHEET TITLE: | NOT TO SCALE | DATE: | 10-23-03 |
| SCALE: | NOT TO SCALE | GRAPHIC SCALE: | 0" = 1" |
| PROJECT MANAGER: | DRL | JOB CAP/DRAWN: | SDL/CAH |
| A/E OF RECORD: | DBR | SHEET No.: | |
| SMRT CAD FILE: | M-502-03034 | | |
| PROJECT No.: | 03034 | | |

M-502