

DISPLAY THIS CARD ON PRINCIPAL FRONTAGE OF WORK CITY OF PORTLAND

BUILDING INSPECTION

Please Read Application And Notes, If Any, Attached

This is to certify that GULF OF MAINE PROPERTIES INC Sign Craft Signs

has permission to Install a 35 sf sign to bldg.

AT 344 COMMERCIAL ST

Permit Number: 05384
PERMIT ISSUED
SEP 22 2005
CITY OF PORTLAND

provided that the person or persons, firm or corporation accepting this permit shall comply with all of the provisions of the Statutes of Maine and of the Ordinances of the City of Portland regulating the construction, maintenance and use of buildings and structures, and of the application on file in this department.

Apply to Public Works for street line and grade if nature of work requires such information.

Notification of inspection must be given and when permission is procured before this building or part thereof is opened or closed-in. **HEAR NOTICE IS REQUIRED.**

A certificate of occupancy must be procured by owner before this building or part thereof is occupied.

OTHER REQUIRED APPROVALS
Fire Dept. _____
Health Dept. _____
Appeal Board _____
Other _____
Department Name _____

Debbie Rowe 9/22/05
Director - Building & Inspection Services

PENALTY FOR REMOVING THIS CARD

City of Portland, Maine - Building or Use Permit Application

389 Congress Street, 04101 Tel: (207) 874-8703, Fax: (207) 874-8716

No:	05-1284	Issue Date:	SEP 22 2005	LCBL:	042 C001001
-----	---------	-------------	-------------	-------	-------------

Location of Construction: 344 COMMERCIAL ST	Owner Name: GULF OF MAINE PROPERTIES I	Owner Address: PO BOX 7549	Phone:
Business Name:	Contractor Name: NeoKraft Signs	Contractor Address: 686 Main St. Lewiston	Phone: 2077829654
Lessee/Buyer's Name	Phone:	Permit Type: Signs - Permanent	Zone: WCZ

Past Use: Commercial	Proposed Use: Commercial install a 35 sf sign to bldg.	Permit Fee: \$100.00	Cost of Work: \$100.00	CEO District: 1
		FIRE DEPT: <input type="checkbox"/> Approved <input type="checkbox"/> Denied	INSPECTION: Use Group Type: Signage IBC-2003 Signature: AMB 9/22/05	
		Signature:	Date:	
Action: <input type="checkbox"/> Approved <input type="checkbox"/> Approved w/Conditions <input type="checkbox"/> Denied				

Permit Taken By: dmartin	Date Applied For: 09/02/2005	Zoning Approval		
------------------------------------	----------------------------------------	------------------------	--	--

2. Building permits do not include plumbing, septic or electrical work. 3. Building permits are void if work is not started within six (6) months of the date of issuance. False information may invalidate a building permit and stop all work..	Special Zone or Reviews <input type="checkbox"/> Shoreland <input type="checkbox"/> Wetland <input type="checkbox"/> Flood Zone <input type="checkbox"/> Subdivision <input type="checkbox"/> Site Plan Maj <input type="checkbox"/> Minor <input type="checkbox"/> MM <input type="checkbox"/> Date: <i>oll</i> 9/13/05	Zoning Appeal <input type="checkbox"/> Variance <input type="checkbox"/> Miscellaneous <input type="checkbox"/> Conditional Use <input type="checkbox"/> Interpretation <input type="checkbox"/> Approved <input type="checkbox"/> Denied Date:	Historic Preservation <input checked="" type="checkbox"/> Not in District or Landmar <input type="checkbox"/> Does Not Require Review <input type="checkbox"/> Requires Review E Approved <input type="checkbox"/> Approved w/Conditions <input type="checkbox"/> Denied Date: <i>S</i>
------------------------------------------------------------------------------------------------------------------------------------------------------------------------------------------------------------------------------------------------------	------------------------------------------------------------------------------------------------------------------------------------------------------------------------------------------------------------------------------------------------------------------------------------------------------------------------------------------------------	-----------------------------------------------------------------------------------------------------------------------------------------------------------------------------------------------------------------------------------------------------------------------------	---------------------------------------------------------------------------------------------------------------------------------------------------------------------------------------------------------------------------------------------------------------------------------------------------------------------

CERTIFICATION

I hereby certify that I am the owner of record of the named property, or that the proposed work is authorized by the owner of record and that I have been authorized by the owner to make this application as his authorized agent and I agree to conform to all applicable laws of this jurisdiction. In addition, if a permit for work described in the application is issued, I certify that the code official's authorized representative shall have the authority to enter all areas covered by such permit at any reasonable hour to enforce the provision of the code(s) applicable to such permit.

SIGNATURE OF APPLICANT

ADDRESS

DATE

PHONE

RESPONSIBLE PERSON IN CHARGE OF WORK, TITLE

DATE

PHONE

City of Portland, Maine - Building or Use Permit

389 Congress Street, 04101 Tel: (207) 874-8703, Fax: (207) 874-8716

Permit No: 05-1284	Date Applied For: 09/02/2005	CBL: 042 C001001
------------------------------	----------------------------------------	----------------------------

Location of Construction: 344 COMMERCIAL ST	Owner Name: GULF OF MAINE PROPERTIES I	Owner Address: PO BOX 7549	Phone:
Business Name:	Contractor Name: NeoKraft Signs	Contractor Address: 686 Main St. Lewiston	Phone: (207) 782-9654
Lessee/Buyer's Name	Phone:	Permit Type: Signs - Permanent	

Proposed Use: Commercial install a 35 sf sign to bldg.	Proposed Project Description: Install a 35 sf sign to bldg.
------------------------------------------------------------------	-----------------------------------------------------------------------

Dept: Zoning **Status:** Approved **Reviewer:** Marge Schmuckal **Approval Date:** 09/13/2005
Note: 09/14/05 shown to site plan review **Ok to Issue:**

Dept: Building **Status:** Approved with Conditions **Reviewer:** Jeanine Bourke **Approval Date:** 09/22/2005
Note:
1) Separate permits are required for any electrical installation
2) Signage Installation to comply with Chapter 31 of the IBC 2003 building code.

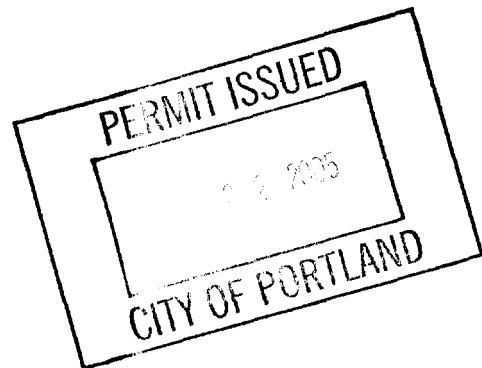

From: Marge Schmuckal
To: port-web:don@[gmri.org]
Date: Wed, Sep 21, 2005 12:55 PM
Subject: Re: Lab Sign Permit

Don,
I **see** that the building reviewers still have this permit in their pile of things to be reviewed. I will **see** if it is something that they can pull out **of** the pile and be reviewed in advance.
Marge

>>> "Don Perkins" <don@[gmri.org]> 09/21 10:04 AM >>>
Hi Marge,

We're starting to get anxious about getting a permit in time to install our sign next **week** prior to our public ribbon cutting next Saturday. Can you give me a sense of where the permit is in the process?

Thanks,

Don

CC: Mike Nugent; William Needelman

THIS IS NOT A PERMIT/CONSTRUCTION MAY NOT COMMENCE UNTIL THE PERMIT IS ISSUED

SIGNAGE APPLICATION

THIS IS NOT A PERMIT

CONSTRUCTION CANNOT NOT COMMENCE UNTIL THE PERMIT IS ISSUED

In the interest of processing your application in the quickest possible manner, please complete the Information below Building or Use Permit.

If you or the property owner owes real estate or personal property taxes or user charge on any property within the City, payment arrangements must be made before permits any kind are accepted.

Total Square Footage of Proposed Structure <i>35 sq. ft.</i>	Square Footage of Lot <i>162,043 sq. ft.</i>
-----------------------------------------------------------------	-------------------------------------------------

Tax Assessor's Chart, Block & Lot Number Chart# <i>42</i> Block# <i>C</i> Lot# <i>1</i>	Owner: <i>Gulf of Maine Properties, Inc. 350 Commercial St. Portland, ME 04101</i>	Telephone #: <i>228-1634</i>
--------------------------------------------------------------------------------------------	-----------------------------------------------------------------------------------------------	---------------------------------

Lessee/Buyer's Name (If Applicable) <i>N/A</i>	Owner's/Purchaser/Lessee Address: <i>350 Commercial St Portland, ME 04101</i>	Total s.f of signs <u><i>35</i></u> x 200 \$ <u><i>70</i></u> , plus \$30.00 TOTAL \$ <u><i>100.00</i></u>
---------------------------------------------------	--------------------------------------------------------------------------------------	-----------------------------------------------------------------------------------------------------------------------------

Current use: *MARINE RESEARCH/EXHIBIT* Proposed use: *SAME*

Project description: *FABRICATE AND INSTALL (1) SINGLE-FACED CANOPY SIGN.*

Applicants Name, Address & Telephone: <i>Gulf of Maine Research Institute 350 Commercial St. Portland, ME 04101 (207) 228-1634</i>
Contractor's Name, Address & Telephone: <i>NEORNET SIGNS, INC. 686 MAIN ST. LEWISTON, ME 04240 (207) 228-1634</i>
Who shall we contact when the permit is ready: <i>DON PERKINS</i>
Telephone: <i>(207) 228-1634</i>

If you would like it mailed, what mailing address should we use:
*Gulf of Maine Research Institute
350 Commercial St.
Portland, ME 04101
ATTN: DON PERKINS*

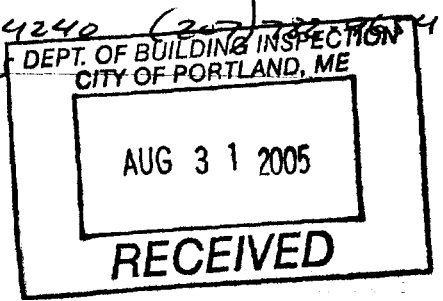

THIS IS NOT A PERMIT/CONSTRUCTION MAY NOT COMMENCE UNTIL THE PERMIT IS ISSUED

If the property is located in a HISTORIC DISTRICT, a separate sketch is required indicating design, dimensions, construction materials and source of illumination if any. A photograph of the building façade should be submitted, showing where each sign is to be installed.

Certification

I hereby certify that I am the Owner of record of the named property, or that the owner of record authorizes the proposed work and that I have been authorized by the owner to make this application as his/her authorized agent. I agree to conform to all applicable laws of this jurisdiction. In addition, if a permit for work described in this application is issued, I certify that the Code Official's authorized representative shall have the authority to enter all areas covered by this permit at any reasonable hour to enforce the provisions of the codes applicable to this permit.

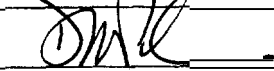
Signature of applicant: 	Date: 8/29/05
-----------------------------------------------------------------------------------------------------------	---------------

Sign Permit Fee: \$30.00 plus \$1.00 per square foot.

A building permit is also required for any awning based on cost of work-\$30.00 for the first \$1,000.00 and \$6.00 for each additional \$1,000.00

BY FILLING OUT THIS APPLICATION IS DOES NOT MEET THAT YOU WILL BE APPROVED FOR THE AMOUNT OF SIGNAGE YOU ARE APPLYING FOR

IT IS SUGGESTED THAT YOU DO NOT ORDER ANY SIGNAGE UNTIL YOU HAVE RECEIVED YOUR SIGN PERMIT THAT HAS BEEN SIGNED BY THE BUILDING, ZONING AND POSSIBLE HISTORICAL OFFICIALS OF THIS OFFICE

THIS IS NOT A PERMIT/CONSTRUCTION MAY NOT COMMENCE UNTIL THE
PERMIT IS ISSUED

Please check off the **following** indicating **that you** have included the below items to expedite the process of this sign application:

- "Certification of Liability" listing the City additionally insured if any portion of the sign abuts or encroaches on the public right of way, or can fall into the public right of way
- Letter of permission from the owner

A sketch plan indicating the following:

- Drawing of the property showing all dimensions of the lot
- Location of all buildings and property setbacks from all buildings
- Driveways and abutting streets showing street frontage and any right of ways
- Indicate on drawing the dimensions of all buildings on the lot
- Define in footage the frontage of your business front
- Indicate on drawing of existing signage and dimensions of each sign
- Indicate on drawing all proposed signage and dimension of each sign
- Sign area height and setback of each existing and proposed freestanding sign
- Certification of flammability required for awning/canopy at time of application
- UL # required for lighted signs at the time of Final Inspection. Failure to provide this information will invalidate the Sign Permit.

The Provisions of Section 3102.0 of the City's Building Code "The BOCA National Building Code 1999 edition" shall govern the construction, alteration, repair and maintenance of outdoor signs together with the associated appurtenant and auxiliary devices in respect to structural and fire safety. In accordance to section 3102.4.4 of BOCA construction documents and owners consent is all follows; "Before any permit is issued for the erection of a sign, Construction Documents shall be filed with the code official showing the dimensions, materials and required details of construction, including loads, stresses and anchorage. The applications shall be accompanied by the written contract of the owner or lessees of the premises upon which the sign is to erected. NO PERMIT CAN OR WILL BE ISSUED UNLESS THIS INFORMATION IS SUBMITTED AND APPROVED BY THE INSPECTIONS OFFICE.

ELECTRICAL SIGNAGE PERMITS/RESPONSIBILITIES

All sign companies or any persons engaged in the installation, interchange or maintenance of signage in the City of Portland must have the Electrician or Electrical Contractor who provided power to the sign(s) or associated equipment apply for an electrical permit in the Inspections Office.

It is the responsibility of your company to contact your sub-contractor or the owner to inform them of this policy. Whether your company does the find connections, which requires a valid Maine Electricians License or your sub contractor provides this service: permits and inspections shall be required.

Failure to comply with this procedure may result in the denial of sign permits by this office for your company or its representation to install or interchange any future signage in the City of Portland.

SIGNAGE PRE-APPLICATION

PLEASE ANSWER ALL QUESTIONS

ADDRESS: 350 Commercial St. ZONE: UC2

OWNER: Gulf of Maine Properties, Inc.

APPLICANT: Gulf of Maine Research Institute

ASSESSOR NO. _____

PLEASE CIRCLE APPROPRIATE ANSWER

SINGLE TENANT LOT? YES NO

MULTI-TENANT LOT? YES NO

FREESTANDING SIGN? (ex. Pole Sign) YES

%

DIMENSIONS N/A HEIGHT N/A

MORE THAN ONE SIGN? YES

DIMENSIONS N/A HEIGHT N/A

SIGN ATTACHED TO BLDG.? YES NO

DIMENSIONS 1'-8 1/2" x 17'-8 1/2"

MORE THAN ONE SLGN? YES NO

DIMENSIONS _____

AWNING: YES IS AWNING BACKLIT? YES HEIGHT OFF SIDEWALK _____
IS THERE ANY MESSAGE, TRADEMARK OR SYMBOL ON IT?

LIST ALL EXISTING SIGNAGE AND THEIR DIMENSIONS:

*** TENANT BLDG. FRONTAGE (IN FEET): ~~204~~ 204' x 2 = 408 ft

*** REQUIRED INFORMATION

AREA FOR COMPUTATION

$2 \times 17.71 = 35.42 \text{ ft}$



YOU SHALL PROVIDE:

A SITE SKETCH AND BUILDING SKETCH SHOWING EXACTLY WHERE EXISTING AND NEW SIGNAGE IS LOCATED MUST BE PROVIDED. SKETCHES AND/OR PICTURES OF PROPOSED ARE ALSO REQUIRED.

SIGNATURE OF APPLICANT: [Signature]

DATE: 8/29/05

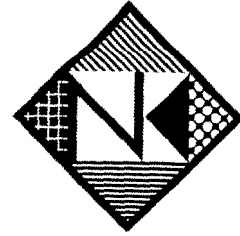
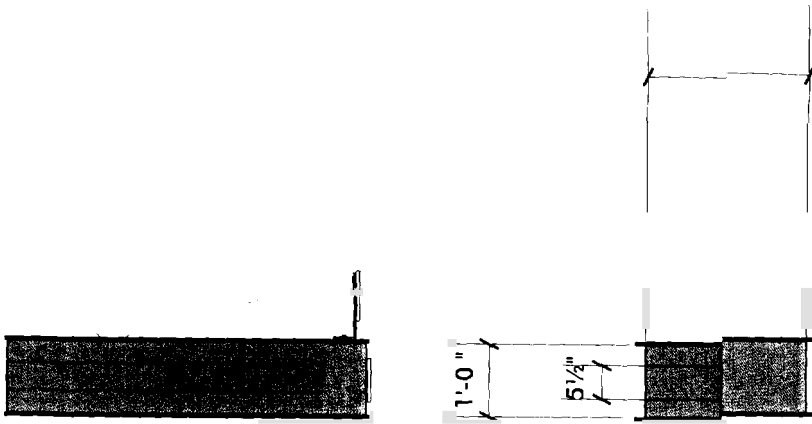

Neokraft
S I G N S

Neokraft Signs Inc.
686 Main Street
Lewiston, Maine 04240
Telephone: 207.782.9654
Facsimile: 207.782.0009
1.800.339.2258
<http://www.neokrah.com>

Custom Sign Fabrication

Except for designs supplied by the client, all ideas, plans or arrangements indicated on this drawing are copyrighted and owned by Neokraft Signs Inc. and shall not be reproduced, used by or disclosed to any person, firm or corporation without written permission of Neokraft Signs Inc.

END VIEW

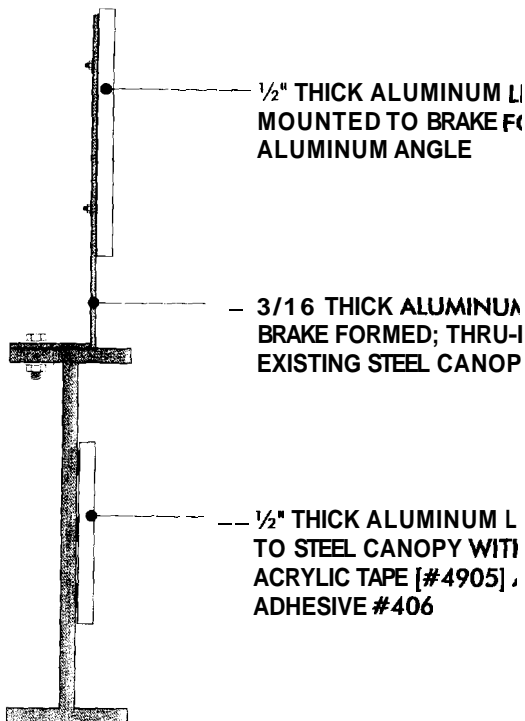

**Gulf of Maine
Research
RL003846**

RED FILE ONLY

Location: 350 Commercial Street

Portland, Maine

Drawing No.: 1 of 1

Drawn by: PFAT

Date: 08.22.2005

Revised:

Gen Ref.:

SECTION
NOT TO SCALE

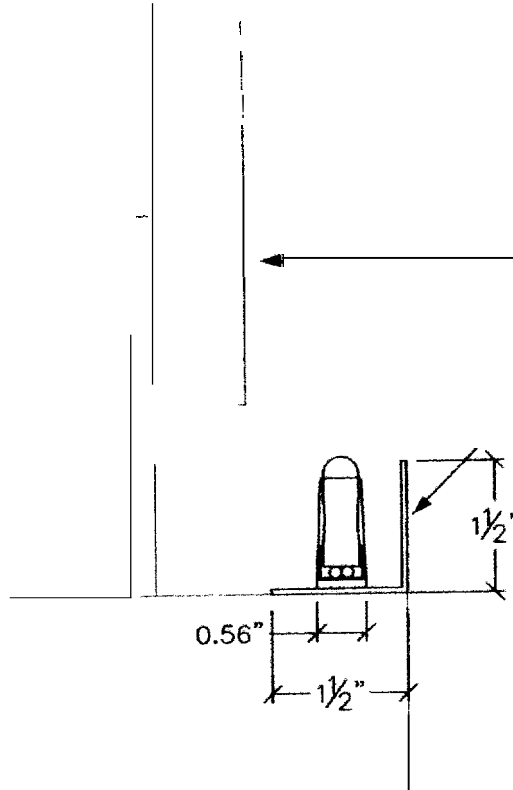

ALUMINUM SIGN LETTERS

LED STRIP LIGHT

PROVIDE ALUMINUM FACE

LED LIGHT STRIP

ILIGHT TECHNOLOGIES:
'PLEXINEON' SERIES

LED LAMPS:
WHITE (#PN2YWI-35)

MOUNTING CLIPS:
STAINLESS STEEL

STRIP LENGTH:
18'-0"

WIRING:
CLASS 2

UL LISTING:
WET LOCATION

TRANSFORMER:
UL OUTDOOR RATED (MOUNT ©
BACK WALL AT LOWER CENTER
OF CANOPY) INPUT VOLTAGE
SHALL BE 277V

SIGN LIGHT DETAIL

6" = 1'-0"

**GULF of MAINE
RESEARCH**

350 Commercial Street
Portland, Maine

08-26-05

Bartlett Design
LIGHTING & ELECTRICAL ENGINEERING
942 WASHINGTON STREET, BATH, ME 04530
TEL (207) 443-5447 FAX (207) 443-5680



Gulf of Maine Properties Inc.

August 29, 2005

Ms. Marge E. Schmuckal
Code Enforcement Officer
City of Portland
389 Congress Street, Room 315
Portland, Maine 04101

Dear Marge:

As required for the City of Portland's building signage permitting process, I am writing to confirm that the Gulf of Maine Research Institute has our permission to install a sign on the canopy of our laboratory at 350 Commercial Street as they are proposing to the City.

Sincerely,

A handwritten signature in black ink, appearing to read "D. Perkins", is written over a horizontal line.

Donald W. Perkins
President

ACORD™ CERTIFICATE OF LIABILITY INSURANCE

DATE (MM/DD/YYYY)
08/22/2005

PRODUCER (207) 774-6257 FAX (207) 774-2994
Clark Associates
2385 Congress Street
P O Box 3543
Portland, ME 04104

THIS CERTIFICATE IS ISSUED AS A MATTER OF INFORMATION ONLY AND CONFERS NO RIGHTS UPON THE CERTIFICATE HOLDER. THIS CERTIFICATE DOES NOT AMEND, EXTEND OR ALTER THE COVERAGE AFFORDED BY THE POLICIES BELOW.

INSURED
Gulf of Maine Research Institute
P O Box 7549
Portland, ME

INSURERS AFFORDING COVERAGE	NAIC #
INSURER A Peerless Ins Co	24198
INSURER B Maine Employers Mutual	0022
INSURER C	
INSURER D	
INSURER E	

COVERAGES

THE POLICIES OF INSURANCE LISTED BELOW HAVE BEEN ISSUED TO THE INSURED NAMED ABOVE FOR THE POLICY PERIOD INDICATED, NOTWITHSTANDING ANY REQUIREMENT, TERM OR CONDITION OF ANY CONTRACT OR OTHER DOCUMENT WITH RESPECT TO WHICH THIS CERTIFICATE MAY BE ISSUED OR MAY PERTAIN. THE INSURANCE AFFORDED BY THE POLICIES DESCRIBED HEREIN IS SUBJECT TO ALL THE TERMS, EXCLUSIONS AND CONDITIONS OF SUCH POLICIES. AGGREGATE LIMITS SHOWN MAY HAVE BEEN REDUCED BY PAID CLAIMS.

INSR ADD'L LTR	INSRD	TYPE OF INSURANCE	POLICY NUMBER	POLICY EFFECTIVE DATE (MM/DD/YY)	POLICY EXPIRATION DATE (MM/DD/YY)	LIMITS
A		GENERAL LIABILITY <input checked="" type="checkbox"/> COMMERCIAL GENERAL LIABILITY <input type="checkbox"/> CLAIMS MADE <input checked="" type="checkbox"/> OCCUR GEN'L AGGREGATE LIMIT APPLIES PER <input checked="" type="checkbox"/> POLICY <input type="checkbox"/> PROJECT <input type="checkbox"/> LOC	CBP9088057	04/26/2005	04/16/2006	EACH OCCURRENCE \$ 100,000 DAMAGE TO RENTED 100,000 MED EXP (Any one person) 5,000 PERSONAL & AOV INJURY 1,000,000 GENERAL AGGREGATE \$ 2,000,000 PRODUCTS - COMP/OP AGG \$ 2,000,000
A		AUTOMOBILE LIABILITY <input checked="" type="checkbox"/> ANY AUTO <input type="checkbox"/> ALL OWNED AUTOS <input type="checkbox"/> SCHEDULED AUTOS <input type="checkbox"/> HIRED AUTOS <input type="checkbox"/> NON-OWNED AUTOS	BA974224	04/26/2004	04/26/2006	COMBINED SINGLE LIMIT (Ea accident) \$ 1,000,000 BODILY INJURY (Per person) \$ BODILY INJURY (Per accident) PROPERTY DAMAGE (Per accident) \$
		GARAGE LIABILITY <input type="checkbox"/> ANY AUTO				AUTO ONLY - EA ACCIDENT \$ OTHER THAN AUTO ONLY: EA ACC \$ AGG \$
A		EXCESS/UMBRELLA LIABILITY <input checked="" type="checkbox"/> OCCUR <input type="checkbox"/> CLAIMS MADE DEDUCTIBLE <input checked="" type="checkbox"/> RETENTION \$ 10,000	CU9760275	04/26/2005	04/26/2006	EACH OCCURRENCE \$ 2,000,000 AGGREGATE \$ 2,000,000 \$ \$
B		WORKERS COMPENSATION AND EMPLOYERS' LIABILITY (ANY PROPRIETOR/PARTNER/EXECUTIVE OFFICER/MEMBER EXCLUDED?) If yes, describe under SPECIAL PROVISIONS below	1810043479	04/26/2005	04/26/2006	<input checked="" type="checkbox"/> WC STATUTORY LIMITS <input type="checkbox"/> OTHER E.L. EACH ACCIDENT \$ 500,000 E.L. DISEASE - EA EMPLOYEE \$ 500,000 E.L. DISEASE - POLICY LIMIT \$ 500,000
		OTHER				

DESCRIPTION OF OPERATIONS (LOCATIONS/VEHICLES/ EXCLUSIONS ADDED BY ENDORSEMENT) SPECIAL PROVISIONS
 City of Portland is an Additional Insured under the General Liability section with regards to the sign at 350 Commercial St in Portland.

CERTIFICATE HOLDER

City of Portland
389 Congress Street
Portland, ME 04101

CANCELLATION

SHOULD ANY OF THE ABOVE DESCRIBED POLICIES BE CANCELLED BEFORE THE EXPIRATION DATE THEREOF, THE ISSUING INSURER WILL ENDEAVOR TO MAIL 10 DAYS WRITTEN NOTICE TO THE CERTIFICATE HOLDER NAMED TO THE LEFT, BUT FAILURE TO MAIL SUCH NOTICE SHALL IMPOSE NO OBLIGATION OR LIABILITY OF ANY KIND UPON THE INSURER, ITS AGENTS OR REPRESENTATIVES.

AUTHORIZED REPRESENTATIVE
Kenneth Ross/BJLR

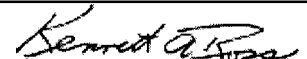

IMPORTANT

If the certificate holder is an ADDITIONAL INSURED, the policy(ies) must be endorsed. A statement on this certificate does not confer rights to the certificate holder in lieu of such endorsement(s).

If SUBROGATION IS WAIVED, subject to the terms and conditions of the policy, certain policies may require an endorsement. A statement on this certificate does not confer rights to the certificate holder in lieu of such endorsement(s).

DISCLAIMER

The Certificate of Insurance on the reverse side of this form does not constitute a contract between the issuing insured(s), authorized representative or producer, and the certificate holder, nor does it affirmatively or negatively amend, extend or alter the coverage afforded by the policies listed thereon.



**Gulf of Maine
Research Institute**

Science. Education. Community.

350 Commercial Street
Portland, ME 04 101

tel 207-772-2321
fax 207-772-6855
www gmri org

August 29,2005

Ms. Marge E. Schmuckal
Code Enforcement Officer
City of Portland
389 Congress Street, Room 3 15
Portland, Maine 04 101

Dear Marge:

Our complete signage permit package is enclosed. Thank you for your advice in advance. Please let me know if anything is missing... I've done my level best to make sure it's complete!

Sincerely,

Donald W. Perkins
President

Officers

Visionary Donor
William G. Waldron
(1936-2001)
Chair
George N. Campbell, Jr
Treasurer
Stephen H. Purdy
Secreta?
James B. Zimpritch
President
Donald W. Perkins, Jr.

Directors

Kathryn L Barber
William A. Burke
George N Campbell, Jr
William L. Caron, Jr
Julian R. Coles
Debra Coyman
Mark Doiron
Marion F. Freeman
David A. Goldberg
Andrew W. Greene
Suzanne E. Hamlin
Timothy A Jacob
William Kourakos
E.J. Lovett, III, Ph.D.
Sean Mahoney
Kevin P. McCarthy
F Michael McClain
Sharon Y. Miller
Kenneth M. Nelson
Stephen H. Purdy
Michael F. Stillings
Persis M. Strong
Ann Staples Waldron
James B. Zimpritch

