

# DISPLAY THIS CARD ON PRINCIPAL FRONTAGE OF WORK CITY OF PORTLAND

Please Read Application And Notes, If Any, Attached

## BUILDING INSPECTION

Permit Number: 070306

**PERMIT ISSUED**  
APR - 6 2007  
CITY OF PORTLAND

This is to certify that AGA REALTY LLC /Trans and Signs

has permission to 66 sf freestanding sign

AT 393 COMMERCIAL ST

042 B00100

provided that the person or persons, firm or corporation accepting this permit shall comply with all of the provisions of the Statutes of this State and of the Ordinances of the City of Portland regarding the construction, maintenance and use of buildings and structures, and of the application on file in this department.

Apply to Public Works for street line and grade if nature of work requires such information.

Notification of inspection must be given and when permission procured before this building or part thereof is laid or closed-in. **24 HOUR NOTICE IS REQUIRED.**

A certificate of occupancy must be procured by owner before this building or part thereof is occupied.

### OTHER REQUIRED APPROVALS

Fire Dept. \_\_\_\_\_

Health Dept. \_\_\_\_\_

Appeal Board \_\_\_\_\_

Other \_\_\_\_\_  
Department Name

*Thomas M. Mahoney 4/6/07*  
Director - Building & Inspection Services

**PENALTY FOR REMOVING THIS CARD**

**City of Portland, Maine - Building or Use Permit Application**

389 Congress Street, 04101 Tel: (207) 874-8703, Fax: (207) 874-8716

Permit No: 07-0306	Issue Date:	CBL: 042 B001001
-----------------------	-------------	---------------------

Location of Construction: 393 COMMERCIAL ST	Owner Name: AGA REALTY LLC	Owner Address: PO BOX 2528	Phone:
Business Name:	Contractor Name: Transworld Signs	Contractor Address: 9310 Parkway Montreal	Phone:
Lessee/Buyer's Name	Phone:	Permit Type: Signs - Permanent	Zone: B5b

Past Use: Commercial / Irving Oil	Proposed Use: Commercial / Irving Oil 66 sf freestanding sign	Permit Fee: \$162.00	Cost of Work: \$162.00	CEO District: 2
		FIRE DEPT: <input type="checkbox"/> Approved <input type="checkbox"/> Denied	INSPECTION: Use Group: <i>Commercial</i> Type: <b>IBC 2003</b>	

Proposed Project Description: 66 sf freestanding sign	Signature:	Signature: <i>Jm 4/6/07</i>
PEDESTRIAN ACTIVITIES DISTRICT (P.A.D.)		
Action: <input type="checkbox"/> Approved <input type="checkbox"/> Approved w/Conditions <input type="checkbox"/> Denied		
Signature:		Date:

Permit Taken By: dmartin	Date Applied For: 03/27/2007	<b>Zoning Approval</b>
-----------------------------	---------------------------------	------------------------

<p>1. This permit application does not preclude the Applicant(s) from meeting applicable State and Federal Rules.</p> <p>2. Building permits do not include plumbing, septic or electrical work.</p> <p>3. Building permits are void if work is not started within six (6) months of the date of issuance. False information may invalidate a building permit and stop all work..</p>	<p><b>Special Zone or Reviews</b></p> <input type="checkbox"/> Shoreland <input type="checkbox"/> Wetland <input type="checkbox"/> Flood Zone <input type="checkbox"/> Subdivision <input type="checkbox"/> Site Plan  Maj <input type="checkbox"/> Minor <input type="checkbox"/> MM <input type="checkbox"/> <i>ok with conditions</i> Date: <i>3/27/07</i>	<p><b>Zoning Appeal</b></p> <input type="checkbox"/> Variance <input type="checkbox"/> Miscellaneous <input type="checkbox"/> Conditional Use <input type="checkbox"/> Interpretation <input type="checkbox"/> Approved <input type="checkbox"/> Denied  Date:	<p><b>Historic Preservation</b></p> <input checked="" type="checkbox"/> Not in District or Landmark <input type="checkbox"/> Does Not Require Review <input type="checkbox"/> Requires Review <input type="checkbox"/> Approved <input type="checkbox"/> Approved w/Conditions <input type="checkbox"/> Denied  Date:
			

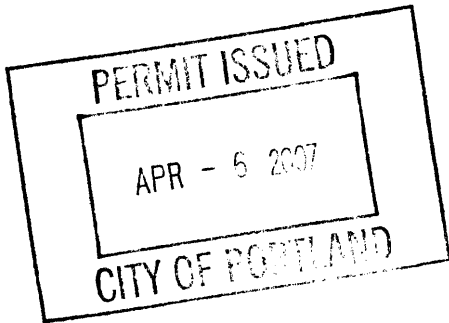

**CERTIFICATION**

I hereby certify that I am the owner of record of the named property, or that the proposed work is authorized by the owner of record and that I have been authorized by the owner to make this application as his authorized agent and I agree to conform to all applicable laws of this jurisdiction. In addition, if a permit for work described in the application is issued, I certify that the code official's authorized representative shall have the authority to enter all areas covered by such permit at any reasonable hour to enforce the provision of the code(s) applicable to such permit.

SIGNATURE OF APPLICANT	ADDRESS	DATE	PHONE
RESPONSIBLE PERSON IN CHARGE OF WORK, TITLE		DATE	PHONE

**City of Portland, Maine - Building or Use Permit**

389 Congress Street, 04101 Tel: (207) 874-8703, Fax: (207) 874-8716

<b>Permit No:</b> 07-0306	<b>Date Applied For:</b> 03/22/2007	<b>CBL:</b> 042 B001001
------------------------------	--	----------------------------

<b>Location of Construction:</b> 393 COMMERCIAL ST	<b>Owner Name:</b> AGA REALTY LLC	<b>Owner Address:</b> PO BOX 2528	<b>Phone:</b>
<b>Business Name:</b>	<b>Contractor Name:</b> Transworld Signs	<b>Contractor Address:</b> 9310 Parkway Montreal	<b>Phone:</b>
<b>Lessee/Buyer's Name</b>	<b>Phone:</b>	<b>Permit Type:</b> Signs - Permanent	

<b>Proposed Use:</b> Commercial / Irving Oil 66 sf freestanding sign	<b>Proposed Project Description:</b> 66 sf freestanding sign
---	---

**Dept:** Zoning      **Status:** Approved with Conditions      **Reviewer:** Marge Schmuckal      **Approval Date:** 03/27/2007

**Note:** **Ok to Issue:**

- 1) This approval is only for the 2 lines of LED price changers. This permit is NOT to include any additional signage on the existing freestanding sign. Any signage for an auxilliary use shall meet the sign ordinance which only permits 15 square foot for such uses. Currently "Blue Canoe" is on the existing freestanding sign. Separate permits shall be required for any additional signage than that being approved with this permit.
- 2) Any LED display SHALL NOT continuously flash, nor contiuously blink, and SHALL NOT scroll. Electronic message board signs SHALL NOT change messages no more than once every four (4) hours. This City and State regulation SHALL BE strictly enforced.

**Dept:** Building      **Status:** Approved with Conditions      **Reviewer:** Tom Markley      **Approval Date:** 04/06/2007

**Note:** **Ok to Issue:**

- 1) Signage Installation to comply with Chapter 31 of the IBC 2003 building code.



# Sign Permit Application

If you or the property owner owes real estate or personal property taxes or user charges on any property within the City, payment arrangements must be made before permits of any kind are accepted.

Location/Address of construction: 393-419 COMMERCIAL ST Zone: \_\_\_\_\_

Total square footage of proposed structure:  
630 SF

Square footage of lot: \_\_\_\_\_  
Lot frontage: \_\_\_\_\_ Tenant frontage: \_\_\_\_\_

Tax Assessor's Chart, Block & Lot  
Chart# 042 Block# 001 Lot# 001

Owner: AGA REALTY INC Telephone: \_\_\_\_\_  
P.O. BOX 2528  
S. PORTLAND, ME 04116

Lessee/buyer's name (If applicable)  
IRVING OIL CORP  
190 COMMERCIAL WAY

Current use: CONVENIENCE STORE Total s.f. of signage 65.9  
Proposed use: SAME \$2.00 per s.f. \$ 132, plus  
\$65.00 base fee

Applicant name, address & telephone:  
CAROLYN A. PARKER  
3 LORION AVENUE  
WORCESTER, MA  
01606

If vacant, prior use: \_\_\_\_\_ Fee: \$ ~~162.00~~ 162.00  
How long has it been vacant? \_\_\_\_\_ Awning-without signage:  
Project description: \$30.00 for first \$1,000  
Number of tenants in lot? \_\_\_\_\_ plus \$9.00 each addict.  
\$1,000  
Fee: \$ \_\_\_\_\_

Freestanding sign?  Yes \_\_\_ No  
More than one sign? \_\_\_ Yes \_\_\_ No  
Sign Attached to Building? \_\_\_ Yes \_\_\_ No  
CANOPY LOGO - YES - NO

Dimensions \_\_\_\_\_ Height \_\_\_\_\_  
Dimensions \_\_\_\_\_ Height \_\_\_\_\_  
Dimensions \_\_\_\_\_ Height \_\_\_\_\_

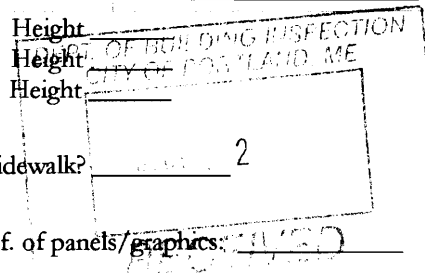

Awning \_\_\_ Yes \_\_\_ No Is awning backlit? \_\_\_ Yes \_\_\_ No Height off sidewalk? 2

Awning Height: \_\_\_\_\_ Length: \_\_\_\_\_ Depth: \_\_\_\_\_

Is there any message, trademark or symbol on it? \_\_\_ Yes \_\_\_ No If Yes, total s.f. of panels/graphics: \_\_\_\_\_

Please describe: \_\_\_\_\_

List ALL existing signage and their dimensions: ALL SIGNS EXISTING TO REMAIN REMOVE AND REPLACE PRICE PANELS W/NEW LED PRICE CHANGERS

Contractor's name, address & telephone: TBD

Who should we contact when the permit is ready: CAROLYN PARKER

Mailing address: 3 LORION AVE, WORCESTER, MA 01606 Phone: (608) 853-1164

Once your permit is approved, we will notify you to come in and pick up your permit and review the requirements with our plan reviewer. Beginning work prior to receiving your permit will result in a violation fee of \$50.00.

Please submit all of the information outlined in the Signage Application Checklist including a building sketch showing exactly where existing is and proposed signage will be located. Please include sketches/pictures of proposed signage. Failure to do so will result in the automatic denial of your permit.

At the discretion of the Planning and Development Department, additional information may be required prior to permit approval. For further information stop by the Building Inspections office, room 315 City Hall or call 874-8703.

I hereby certify that I am the Owner of record of the named property, or that the owner of record authorizes the proposed work and that I have been authorized by the owner to make this application as his/her authorized agent. I agree to conform to all applicable laws of this jurisdiction. In addition, if a permit for work described in this application is issued, I certify that the Code Official's authorized representative shall have the authority to enter all areas covered by this permit at any reasonable hour to enforce the provisions of the codes applicable to this permit.

Signature of applicant: Carolyn Parker

Date: 3/1/87

This is not a Permit; you may not commence any work until the Permit is issued.

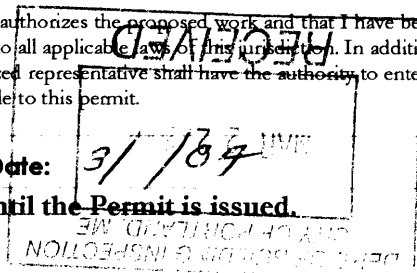

# CAROLYN A. PARKER

CONSULTING

March 14, 2007

**City of Portland**  
**389 Congress Street**  
**Inspections Division – Room 315**  
**Portland, ME 04101**

Attn: Ms. Marge Schmuckel  
Inspections Division

Irving Oil Corporation  
393-419 Commercial Street  
Portland, ME 04101  
Delivery: Reg. Mail

Dear Ms. Schmuckel,

As mentioned in our telephone conversation Irving Oil wishes to remove and replace the existing price panels with new LED price changers. Enclosed please find (1) one Sign Permit Application and the following cut sheets for your review: (1) one drawing showing the existing pylon, (1) one "Sample" drawing of what the LED price changers will look once installed and (1) one detail of the electronic gas price display. Due to the fact the existing pylon sign is only 6'-0" wide the price can no longer remain side by side, therefore we will be removing both the price panel and existing Bakery-Deli panel and install (2) two new LED price changers per the enclosed sample photo. The overall square footage of the price sign will remain the same.

Lastly, enclosed please find check #891 in the amount of \$197.00 for the permit fee, I assumed the whole square footage of the pylon to figure the fee. Please review the Sign Permit package and if you find everything is in order please return the permit to me in the enclosed self-addressed stamped envelope. If you have questions or need additional information please call me at (508) 853-1167. Thank you in advance for your time in helping to expedite this matter.

Sincerely,



Carolyn A. Parker

Cc: Irving Oil  
File

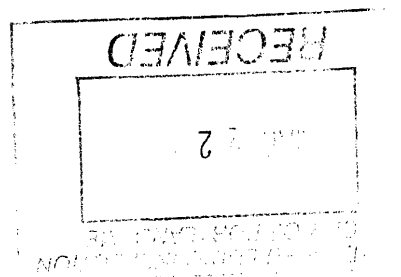

---

SPECIALIZING IN THE PETROLEUM INDUSTRY  
*Project Management, Permit Expediting, Drafting & Fire Suppression Plans*

3 Lorion Avenue, Worcester, MA 01606 • Tel: 508-853-1167 • Fax: 508-853-1176 • Cell: 774-239-2781 • capconsulting@verizon.net

November 29, 2005

Irving Oil Corporation  
190 Commerce Way  
Portsmouth, NH 03801

Attn: Chuck Blanchette

Re: Irving Oil Corporation/AGA Realty LLC  
393 Commercial Street, Portland, Maine property

Dear Mr. Blanchette:

Please let this letter confirm my authorization for the Tenant, Irving Oil Corporation, to make modifications and renovations to the existing site signage located at the above referenced property. I have attached to this letter a copy of your plan with the proposed modifications and renovations entitled "Exhibit A".

If you have any questions, please feel free to contact me. Thank you.

Very truly yours,

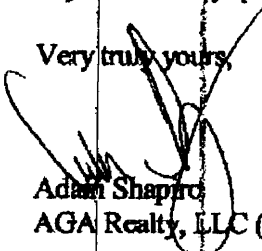

Adam Shapiro  
AGA Realty, LLC (Landlord)

/ksc

Attachments

Table 2.14

**Gas Stations - All Zones Where Permitted**

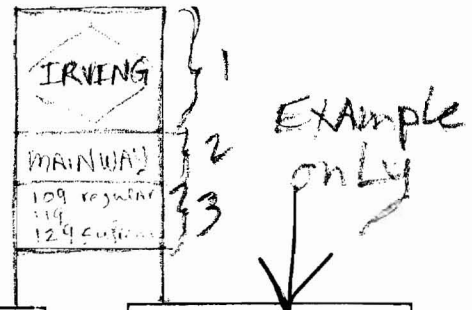

	B-1, IB	B-4	All Other Zones
<b>Freestanding Signs</b>			
- Area	1 2 32 sq. ft./10 sq. ft. 3 /20 sq. ft. (a)	1 2 60 sq. ft./20 sq. ft./ 30 sq. ft. (a)	1 2 40 sq. ft./15 sq. ft./ 3 24 sq. ft. (a)
- Height	16 feet	35 feet	18 feet
- Setback	5 feet	5 feet	5 feet
- # Permitted per lot	1/major principal and auxilliary use + 1 price sign (a)(b)	same	same

(a) Area limits are broken down according to sign types, as follows: sign area for principal use/sign areas for additional major auxilliary use(s) on site (for example, car wash, repair garage, convenience store)/sign area for gas prices. In the B-1 and IB zones, for example, the maximum permitted sign area for the principal use is 32 sq. ft. The maximum permitted sign area for each auxilliary use is 10 sq. ft. and the maximum permitted area for the gas price sign is 20 sq. ft.

(b) All signs shall be mounted on the same base.

**Building/Canopy Signs**

	All Zones
- Maximum permitted area	30 sq. ft. for principal building sign/10 sq. ft. for each additional major activity/20 sq. ft. for canopy sign
- Square feet per linear foot of building facade on which sign will be placed	na
- Maximum vertical dimension	2 feet
- # Permitted per lot	1 building sign for each major activity/2 canopy signs (a)

(a) Maximum two signs allowed on large canopy; one each on opposite facing planes.

**Miscellaneous Signs**

Signs placed on individual pumps shall be considered incidental signs and shall not be calculated in total allowable sign area. Incidental signs shall not be limited in number. However, no individual sign shall exceed 1 sq. ft.

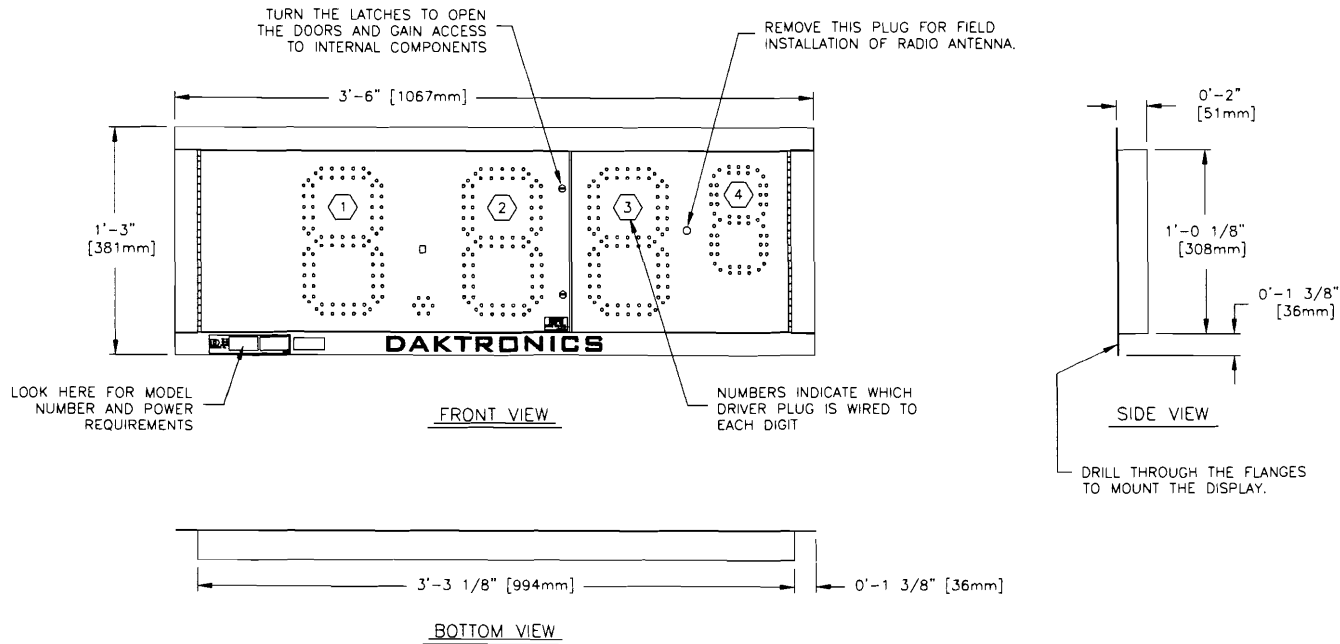

**NOTES:**

**GENERAL**

THIS IS A SINGLE FACED DROP-IN DISPLAY, INTENDED TO BE MOUNTED IN A RECTANGULAR OPENING IN A LARGER SIGN.

RECOMMENDED ROUGH OPENING DIMENSIONS: 39 5/8" X 12 5/8".

LARGE DIGITS ARE 10" NOMINAL HEIGHT. THE SMALL DIGIT IS 7" NOMINAL HEIGHT.

DIGIT LEDS MAY BE RED, AMBER, OR GREEN; TO BE SPECIFIED AT TIME OF ORDER.

**MECHANICAL**

CABINET IS CONSTRUCTED OF ALUMINUM SHEET, 0.063" THICK.

ESTIMATED WEIGHT IS ABOUT 25 LBS [11 KG].

DRILL THROUGH THE FLANGES OF THE CABINET TO ATTACH THE DISPLAY TO BASE STRUCTURE USING APPROPRIATE HARDWARE FOR THE SITE CONDITIONS.

DAKTRONICS IS NOT RESPONSIBLE FOR THE MOUNTING STRUCTURE OR FOR THE ADEQUACY OF ATTACHMENT TO THE STRUCTURE. STRUCTURE AND ATTACHMENT MUST CONFORM TO ALL APPLICABLE BUILDING CODES.

**ELECTRICAL**

MAXIMUM POWER DEMAND IS 75 WATTS.

PROVIDE A 120V AC, 15 AMP CIRCUIT FOR POWER.

SERVICE AND ELECTRICAL HOOKUP ACCESS IS THROUGH THE FRONT OF THE DISPLAY ONLY.

IF THE POWER TO THE DISPLAY IS TEMPORARILY INTERRUPTED, DISPLAY FUNCTIONS WILL BE RETAINED IN MEMORY TO CONTINUE OPERATION WHEN POWER IS RESTORED.

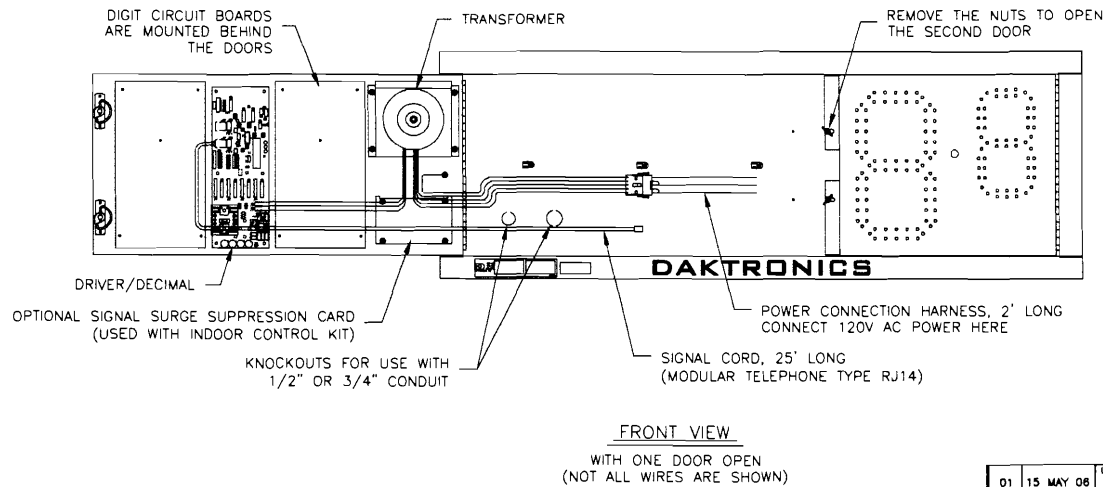

THE CONCEPTS EXPRESSED AND DETAILS SHOWN ON THIS DRAWING ARE CONFIDENTIAL AND PROPRIETARY. DO NOT REPRODUCE BY ANY MEANS, INCLUDING ELECTRONICALLY WITHOUT THE EXPRESSED WRITTEN CONSENT OF DAKTRONICS, INC. COPYRIGHT 2005 DAKTRONICS, INC.

DAKTRONICS, INC. BROOKINGS, SD 57006

PROJ: GAS PRICE DISPLAYS

TITLE: SHOP DRAWING, DF-2009-10-NA-DI

DES. BY: DRAWN BY: M LEOPOLD DATE: 28 DEC 05

REV.	DATE	DESCRIPTION	BY	APPR.
01	15 MAY 06	UPDATED THE CABINET TO THE REVISED DESIGN.	MGL	

REVISION	APPR. BY:	1356-R04B-260454
01	SCALE: 1=B	



SAMPLE PYLON WITH LED DISPLAY



*only  
↓  
LED Price  
changes*

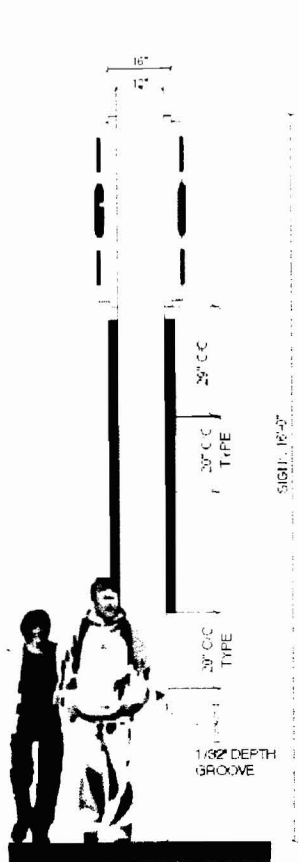

**LEFT SIDE VIEW**  
SCALE: 3/8" = 1'-0"

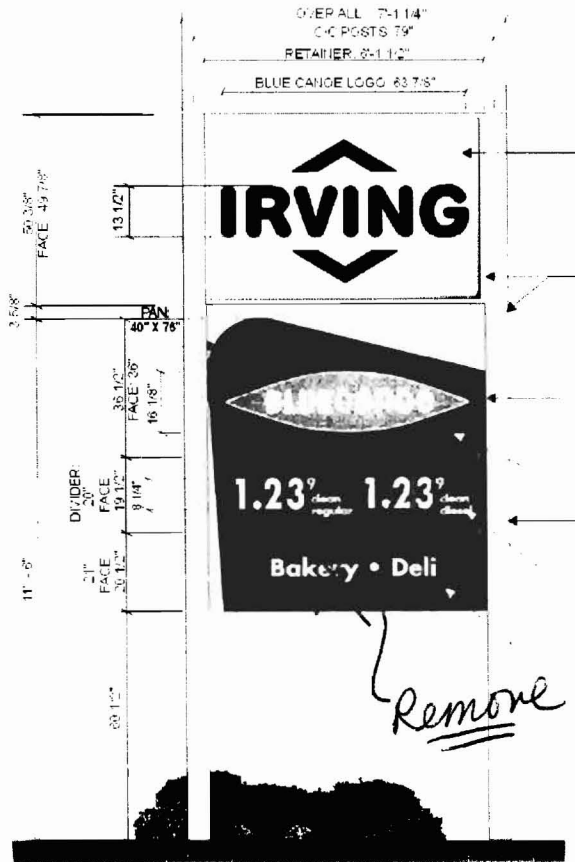

**A FRONT VIEW / DAY TIME**  
SCALE: 3/8" = 1'-0"

(2) WHITE P/3M 7328 ROUNDED  
.177 THK "MVAC HT" FACE WITH BLOCKS  
WITH MOLDED LOGO  
VINYL GRAPHICS APPLIED  
ON FIRST SURFACE  
RED ARROW #3630-83  
"IRVING" IRVING BLUE #VT12138

ALUM COVERING  
AND INT 10-12-13 (3/4") RETAINER  
PAINTED WHITE TO MATCH  
(COLOR AND FINISH) WITH WHITE MVAC

CABINET WITH 2" FACE RETAINER AND  
H-DIVIDERS #8SH-2100 (2)  
WITH VISIBLE GROOVE ON FACES AND SIDES  
PAINTED TO MATCH  
(COLOR AND FINISH)  
WITH THE VINYL IRVING BLUE #VT12138

(2) 150 THK. FANNED FACES (MOLDED GANGE) "MVAC HT" PIGMENTED WHITE  
#7328. GRAPHICS MADE OF VINYL APPLIED ON FIRST SURFACE  
BACKGROUND IRVING BLUE TRANSLUCENT #VT12138  
(APPLIED IN 2 SECTIONS)

FORMED .081 THK ALUMINUM CLADDING  
ATTACHED TO THE POST  
PAINTED WHITE TO MATCH WITH WHITE MVAC  
(COLOR AND FINISH)

(2) 150 THK FLAT "MVAC HT" FACE PIGMENTED WHITE #7328 WITH  
VINYL GRAPHICS APPLIED ON FIRST SURFACE  
BACKGROUND IRVING BLUE TRANSLUCENT #VT12138. WHITE COPY (FACE).  
AVAILABLE ZPL CHANGE NUMBERS AND WINDOW OPENING SEE ANNEX

(2) 150 THK FLAT "MVAC HT" FACE PIGMENTED WHITE #7328 WITH  
VINYL GRAPHICS APPLIED ON FIRST SURFACE  
BACKGROUND IRVING BLUE TRANSLUCENT #VT12138. WHITE COPY (FACE)

**FACE MOLDING DETAIL**

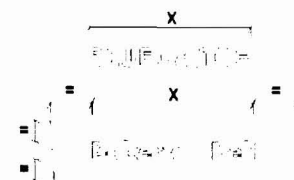

**GRAPHIC DETAIL**

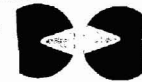

**FLAT GRAPHIC**



**MOLDED FACE DETAIL**



**COLORS DETAIL**

- Yellow #3630-015 3M #PMS109
- Blue #3630-87 3M #PMS Process Blue
- IRVING BLUE #VT 12138
- Face
- GREEN 3M #3630-28

*total 24 sq permitted  
approved*

SEE TECHNICAL DETAILS AND FABRICATION  
ON DRAWING #209 M AND M  
SITE WIND LOAD: \_\_\_\_\_ Kpa 1/30

*[Handwritten signature]*

*20" x 6.13' = 10.24#  
1.67' x 6.13' = 10.24#  
one panel*

*10.24# x 2 = 20.48#*

TRANSWORLD SIGNS 4510 Parkway Montreal, QC H3J 1P7 Phone: 514-352-5520 Fax: 514-352-5559 Email: info@transworldsigns.com	Revisions		Date	By
	No	Description		
<small>This drawing, including graphic layout and technical details is the property of Transworld Signs Co and cannot be reproduced, copied or used without prior authorization from Transworld Signs Co.</small>	No.1			
	No.2			
	No.3			
	No.4			
	No.5			
	No.6			

**IRVING**

Customer: **IRVING #70485**  
Address: **COMMERCIAL STREET, PORTLAND, ME** Date: **04 / 08 / 2005**  
Rep: **G. FRENETTE** Work Order: **X**  
Designer: **A. LEBLANC** Drawing #: **200107m1 1/1**

Source: 89-02-05-58 15-02 04 Loi sur l'accès à l'information en vertu de la loi sur l'accès à l'information du Québec

CAROLYN A. PARKER  
CONSULTING

April 3, 2007

City of Portland  
389 Congress Street  
Inspections Division – Room 315  
Portland, ME 04101

Attn: Ms. Donna Martin  
Code Enforcement

Irving Oil Corporation  
393-419 Commercial Street  
Portland, ME 04101  
Delivery: Reg. Mail

Dear Ms. Martin,

Per a letter sent from you dated March 26, 2007, I am attaching a new Sign Permit Application and Checklist along with the following cut sheets for your review: (1) one drawing showing the existing pylon, (1) one "Sample" drawing of what the LED price changers will look once installed and (1) one detail of the electronic gas price display. Due to the fact the existing pylon sign is only 6'-0" wide the price can no longer remain side by side, therefore we will be removing both the price panel and existing Bakery-Deli panel and install (2) two new LED price changers per the enclosed sample photo. The overall square footage of the price sign will remain the same.

Lastly, enclosed please find check #908 in the amount of \$162.00 for the permit fee, I assumed the whole square footage of the pylon to figure the fee. Please review the Sign Permit package and if you find everything is in order please return the permit to me in the previously sent self-addressed stamped envelope. If you have questions or need additional information please call me at (508) 853-1167. Thank you in advance for your time in helping to expedite this matter.

Sincerely,

  
Carolyn A. Parker

Cc: Irving Oil  
File

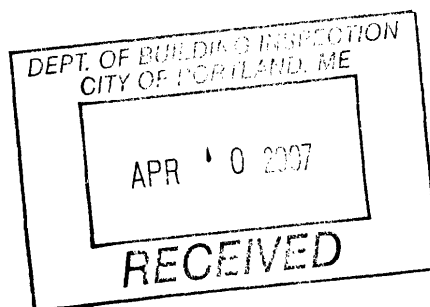

---

SPECIALIZING IN THE PETROLEUM INDUSTRY  
*Project Management, Permit Expediting, Drafting & Fire Suppression Plans*

3 Lorion Avenue, Worcester, MA 01606 • Tel: 508-853-1167 • Fax: 508-853-1176 • Cell: 774-239-2781 • capconsulting@verizon.net

RECEIVED  
 APR 10 2007  
 CITY OF BROOKINGS, SD  
 DIVISION OF PUBLIC UTILITIES  
 NOTED  
 GENERAL

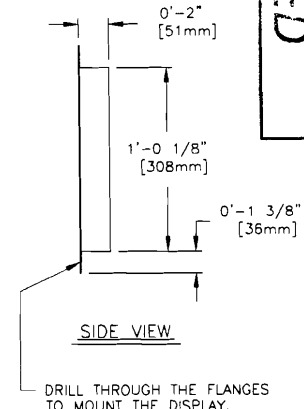
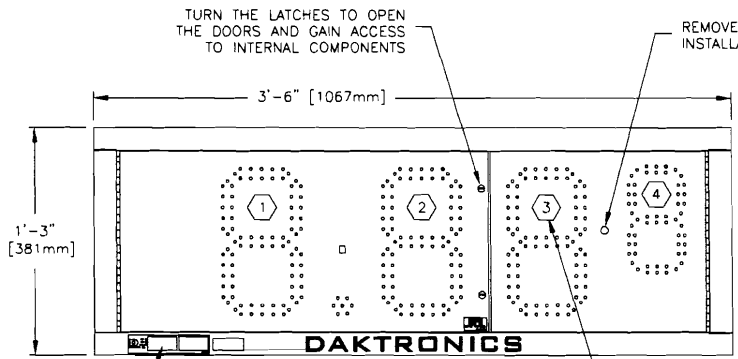

LOOK HERE FOR MODEL NUMBER AND POWER REQUIREMENTS

FRONT VIEW

NUMBERS INDICATE WHICH DRIVER PLUG IS WIRED TO EACH DIGIT

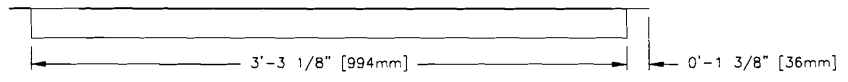

BOTTOM VIEW

THIS IS A SINGLE FACED DROP-IN DISPLAY. INTENDED TO BE MOUNTED IN A RECTANGULAR OPENING IN A LARGER SIGN.  
 RECOMMENDED ROUGH OPENING DIMENSIONS: 39 5/8" X 12 5/8".

LARGE DIGITS ARE 10" NOMINAL HEIGHT. THE SMALL DIGIT IS 7" NOMINAL HEIGHT.  
 DIGIT LEDS MAY BE RED, AMBER, OR GREEN; TO BE SPECIFIED AT TIME OF ORDER.

**MECHANICAL**  
 CABINET IS CONSTRUCTED OF ALUMINUM SHEET, 0.063" THICK.  
 ESTIMATED WEIGHT IS ABOUT 25 LBS [11 KG].  
 DRILL THROUGH THE FLANGES OF THE CABINET TO ATTACH THE DISPLAY TO BASE STRUCTURE USING APPROPRIATE HARDWARE FOR THE SITE CONDITIONS.

DAKTRONICS IS NOT RESPONSIBLE FOR THE MOUNTING STRUCTURE OR FOR THE ADEQUACY OF ATTACHMENT TO THE STRUCTURE. STRUCTURE AND ATTACHMENT MUST CONFORM TO ALL APPLICABLE BUILDING CODES.

**ELECTRICAL**  
 MAXIMUM POWER DEMAND IS 75 WATTS.  
 PROVIDE A 120V AC, 15 AMP CIRCUIT FOR POWER.  
 SERVICE AND ELECTRICAL HOOKUP ACCESS IS THROUGH THE FRONT OF THE DISPLAY ONLY.  
 IF THE POWER TO THE DISPLAY IS TEMPORARILY DISRUPTED, DISPLAY FUNCTIONS WILL BE RETAINED IN MEMORY TO CONTINUE OPERATION WHEN POWER IS RESTORED.

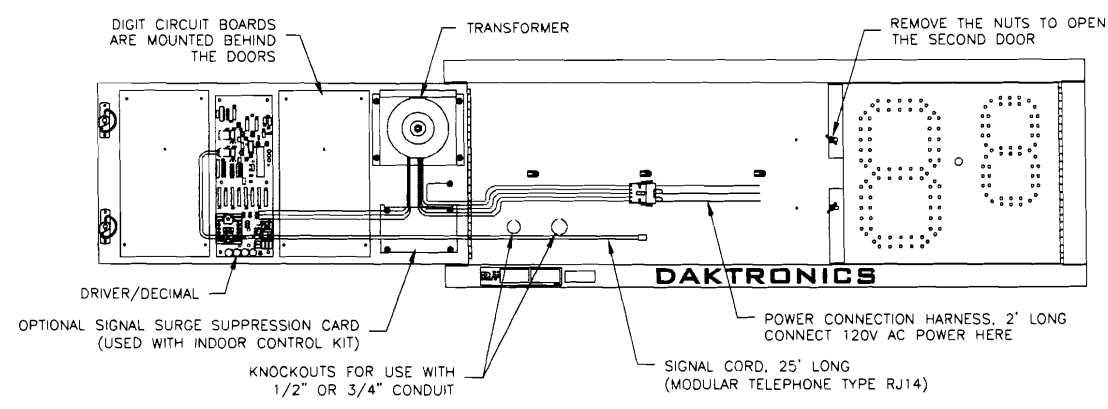

FRONT VIEW  
 WITH ONE DOOR OPEN  
 (NOT ALL WIRES ARE SHOWN)

THE CONCEPTS EXPRESSED AND DETAILS SHOWN ON THIS DRAWING ARE CONFIDENTIAL AND PROPRIETARY. DO NOT REPRODUCE BY ANY MEANS, INCLUDING ELECTRONICALLY WITHOUT THE EXPRESSED WRITTEN CONSENT OF DAKTRONICS, INC. COPYRIGHT 2005 DAKTRONICS, INC.

DAKTRONICS, INC. BROOKINGS, SD 57006			
PROJ: GAS PRICE DISPLAYS			
TITLE: SHOP DRAWING, DF-2009-10-NA-DI			
DES. BY:	DRAWN BY: M LEOPOLD		DATE: 28 DEC 05
REVISION	APPR. BY:	1356-R04B-260454	
01	SCALE: 1=8		

REV.	DATE	DESCRIPTION	BY	APPR.
01	15 MAY 06	UPDATED THE CABINET TO THE REVISED DESIGN.	MGL	

# SAMPLE PYLON WITH LED DISPLAY

DEPT. OF BUSINESS INSPECTION  
CITY OF PORTLAND, ME  
APR 10 2007  
RECEIVED

**IRVING**

BLUEcane

2.39<sup>9</sup> clean regular

2.72<sup>9</sup> clean diesel

**Bakery**

Amato's

xpress

Pizza - Pasta  
Sandwiches



**Associate**

THIS ONLY  
REPRESENTS  
WHAT THE  
LED PRICE  
CHANGERS  
WILL LOOK  
LIKE !!

November 29, 2005

Irving Oil Corporation  
190 Commerce Way  
Portsmouth, NH 03801

Attn: Chuck Blanchette

Re: Irving Oil Corporation/AGA Realty LLC  
393 Commercial Street, Portland, Maine property

Dear Mr. Blanchette:

Please let this letter confirm my authorization for the Tenant, Irving Oil Corporation, to make modifications and renovations to the existing site signage located at the above referenced property. I have attached to this letter a copy of your plan with the proposed modifications and renovations entitled "Exhibit A".

If you have any questions, please feel free to contact me. Thank you.

Very truly yours,

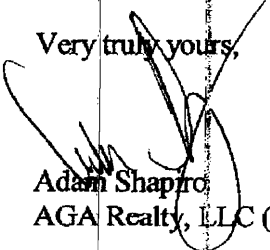

Adam Shapiro  
AGA Realty, LLC (Landlord)

/ksc

Attachments

