

1 TYPICAL CONFERENCE FRONT-OPTION A
1/4" = 1'-0"

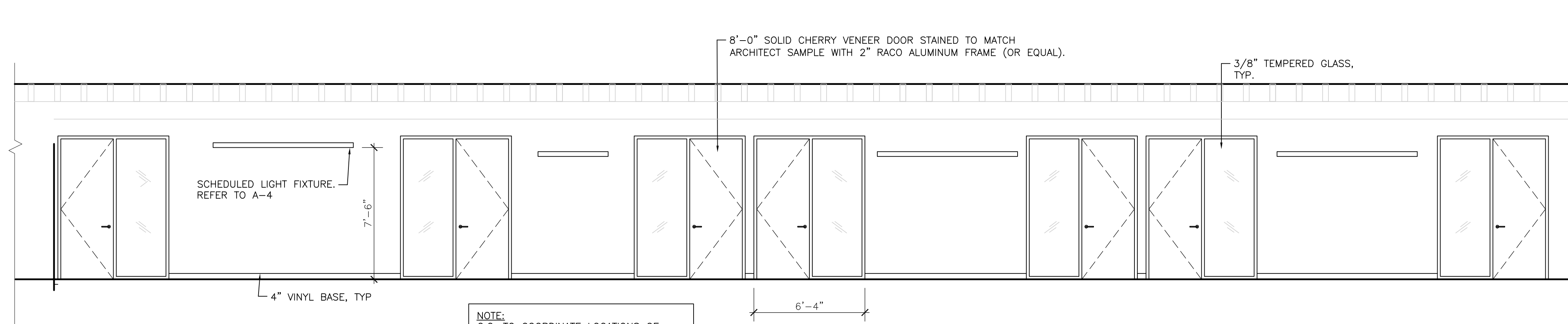

2 TYPICAL OFFICE FRONT ELEVATION-OPTION A
1/4" = 1'-0"

NOTE:
G.C. TO COORDINATE LOCATIONS OF GRILLES ON DEMISING WALLS IN OFFICES WITH ARCHITECT AND ENGINEER.

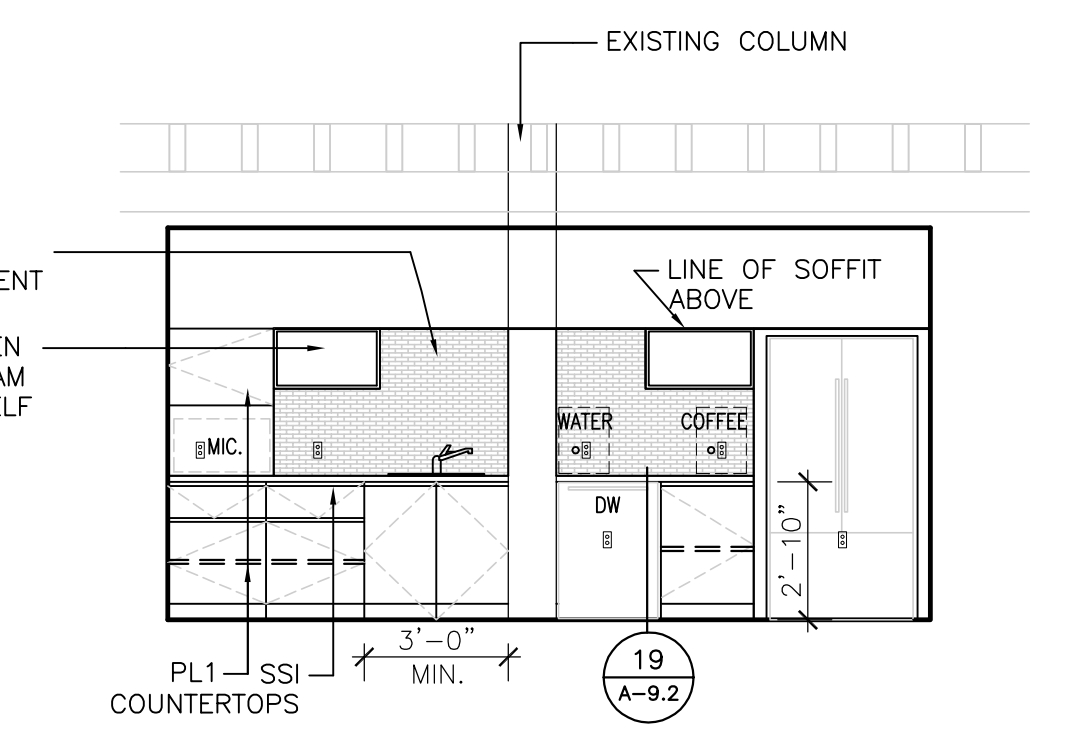

3 TYPICAL PANTRY/COPY
1/4" = 1'-0"

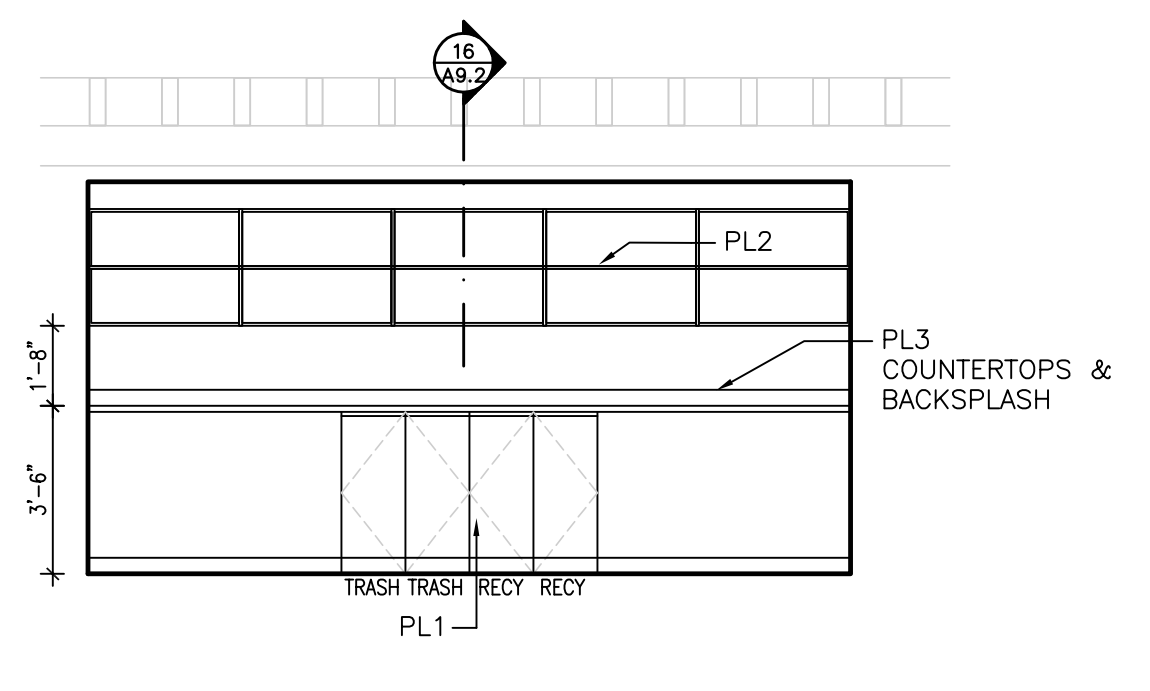

4 TYPICAL PANTRY/COPY
1/4" = 1'-0"

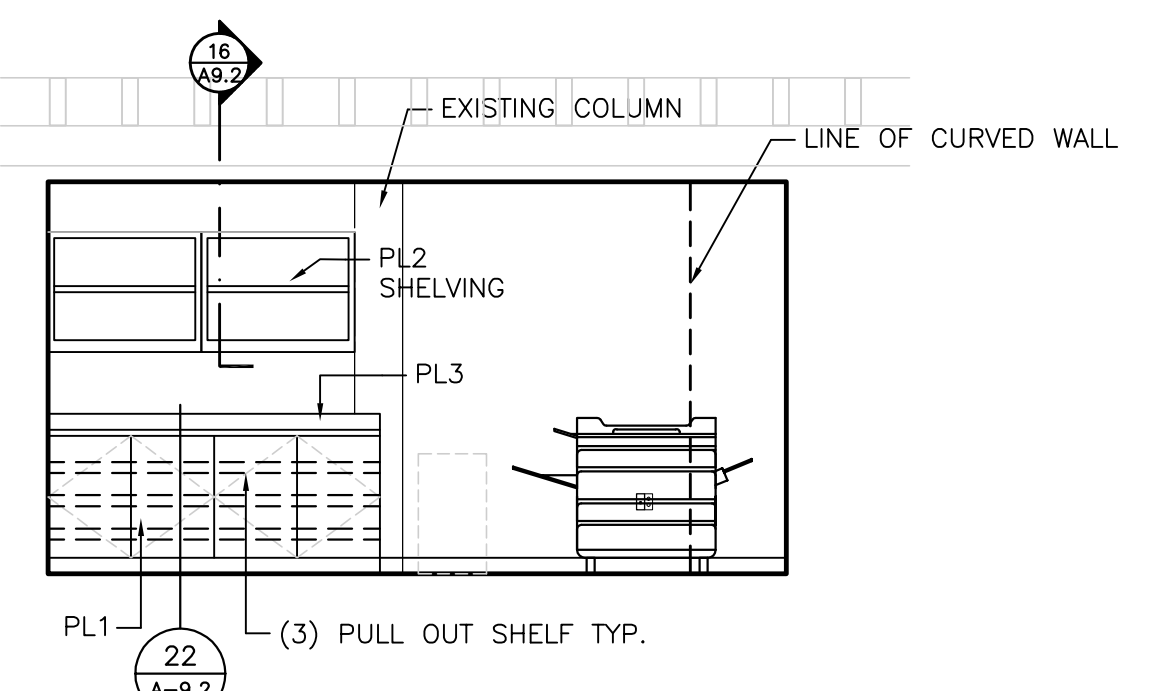

5 COPY 232
1/4" = 1'-0"

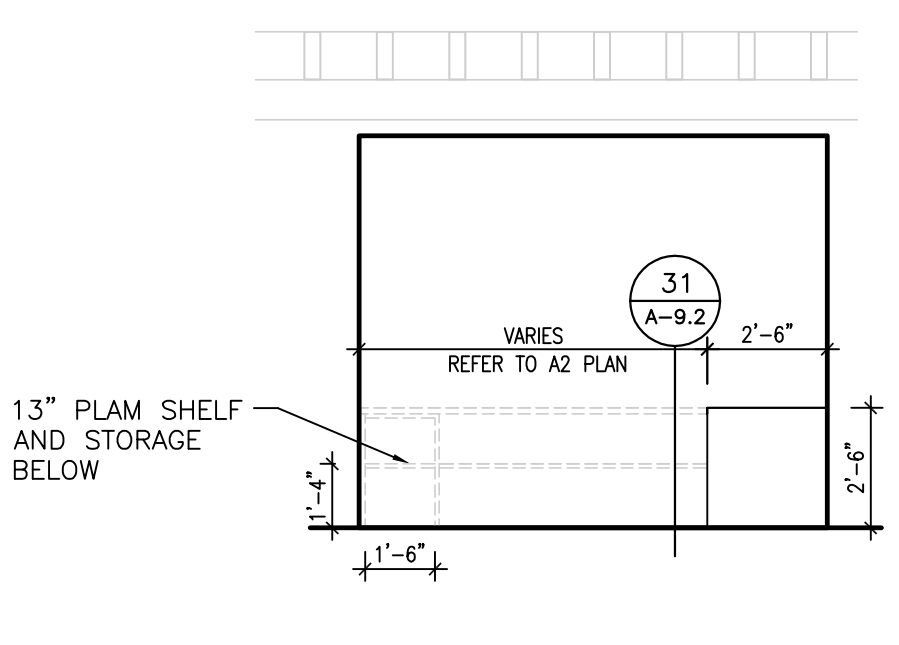

6 TYPICAL PARALEGAL INTERIOR OFFICE
1/4" = 1'-0"

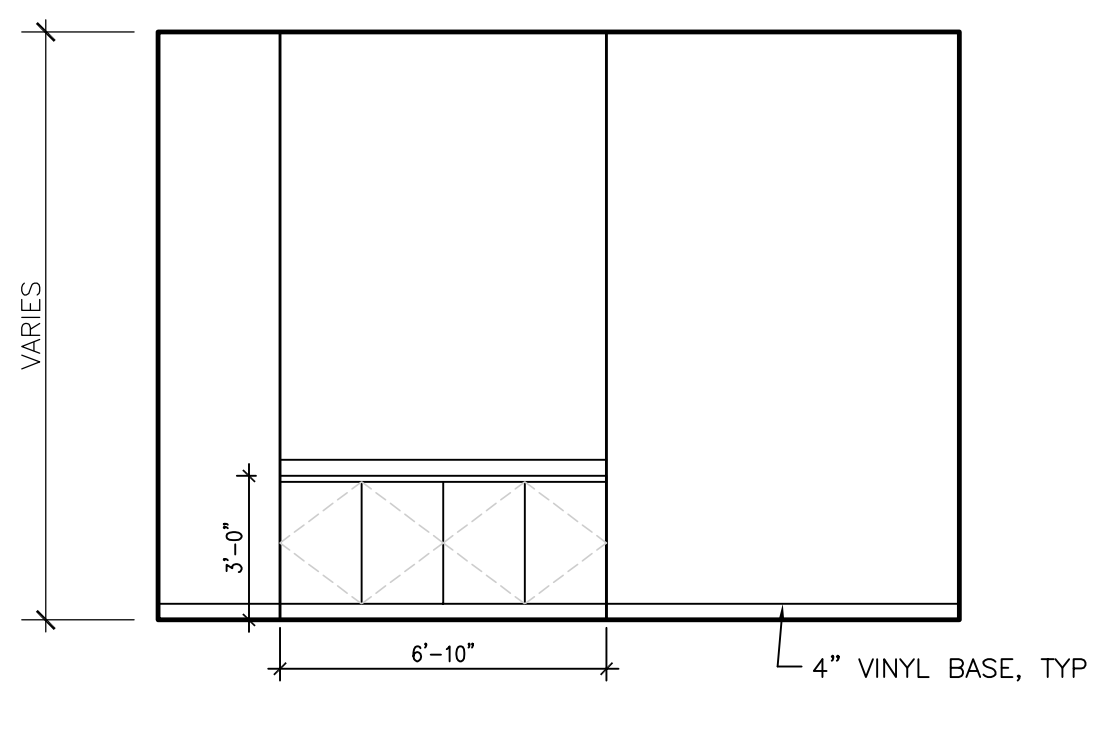

7 TYPICAL PARALEGAL INTERIOR OFFICE
1/4" = 1'-0"

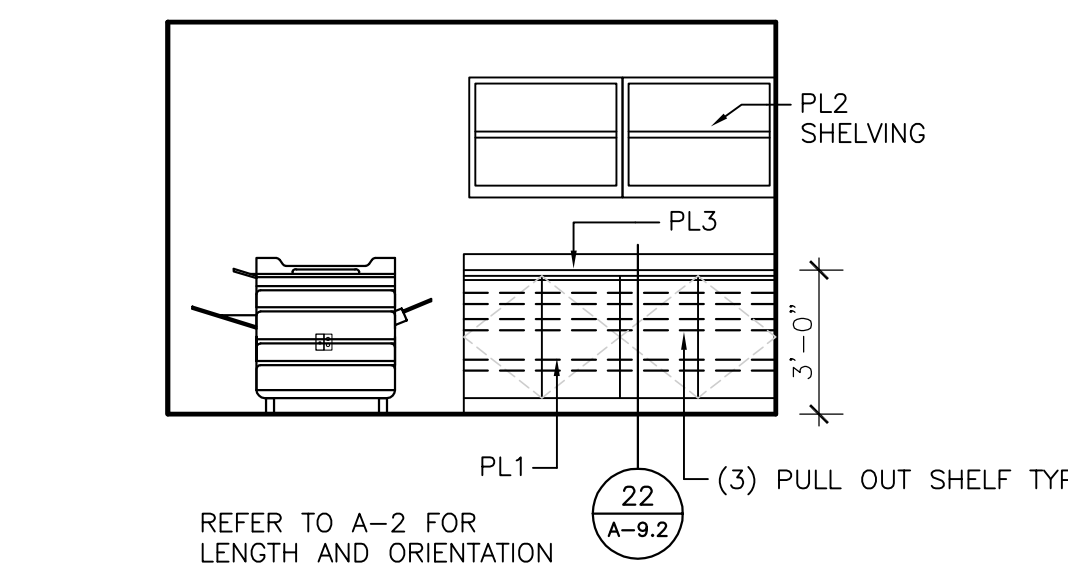

8 TYPICAL COPY
1/4" = 1'-0"

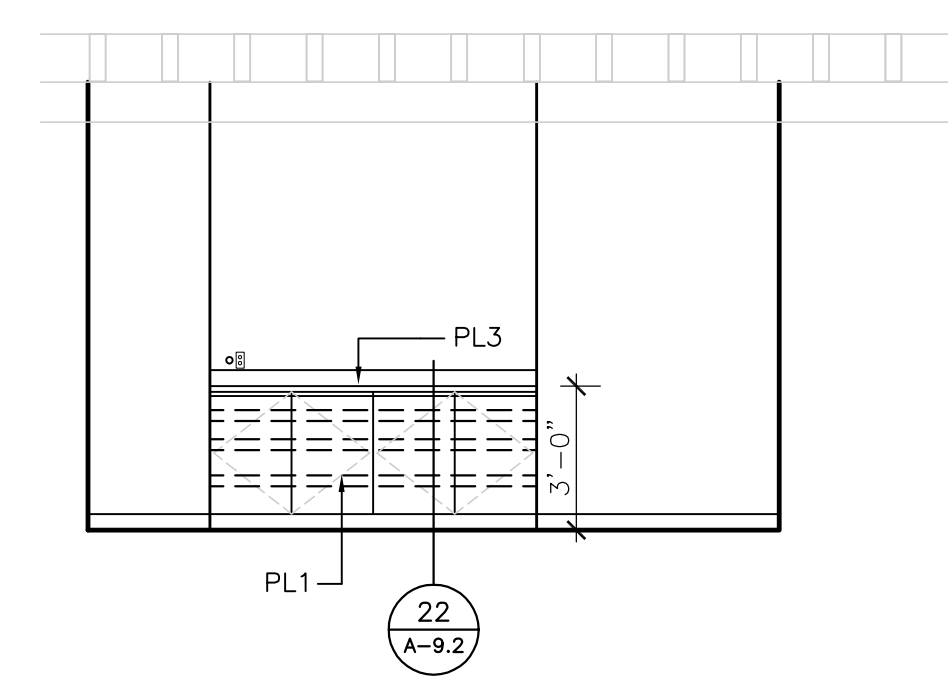

9 PRINTER STATION-CORRIDOR 202
1/4" = 1'-0"

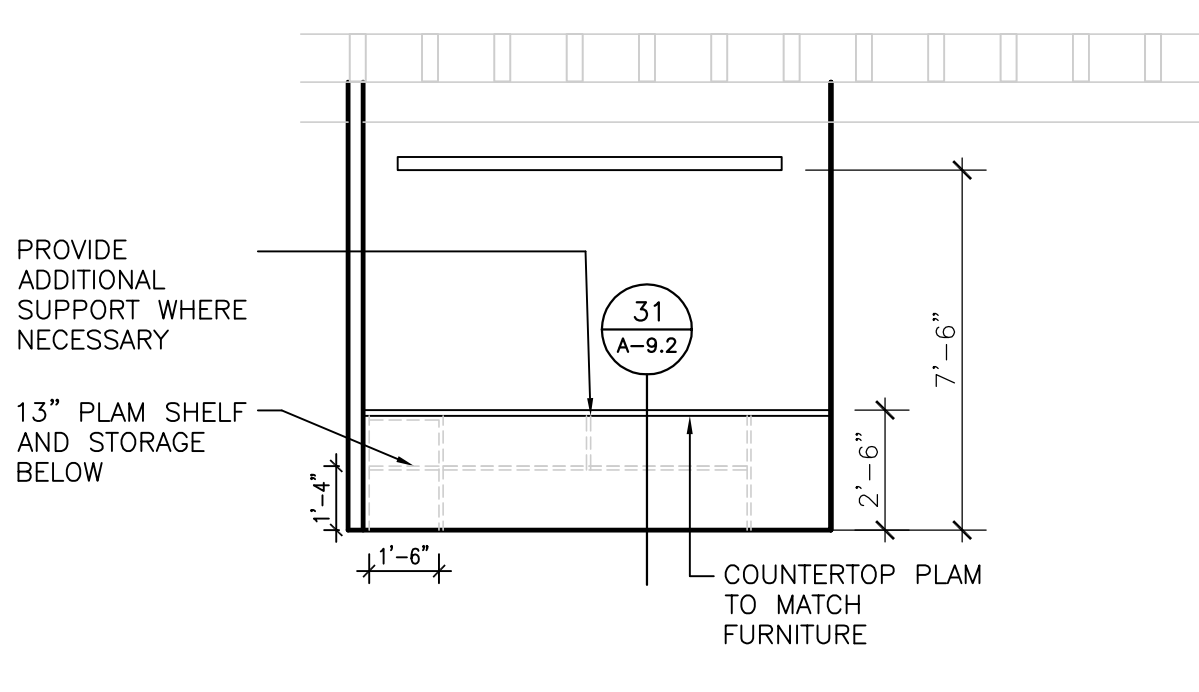

10 TYPICAL OPEN OFFICE
1/4" = 1'-0"

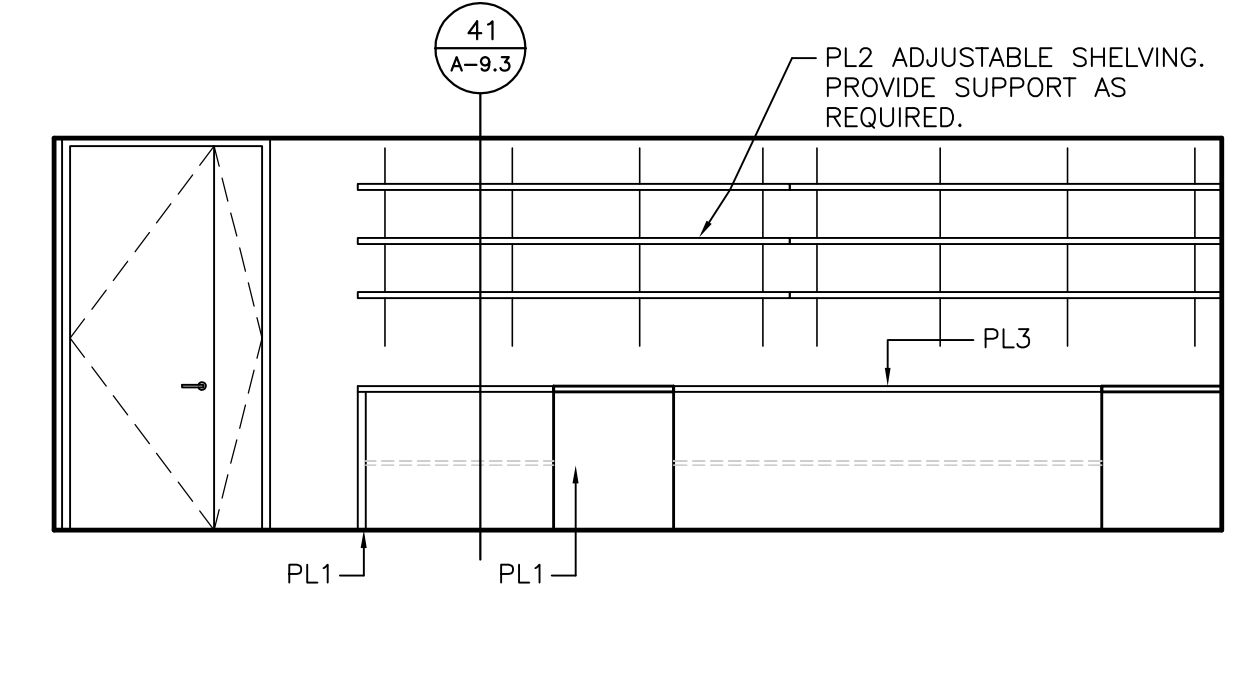

11 PRODUCTION ROOM 207
1/4" = 1'-0"

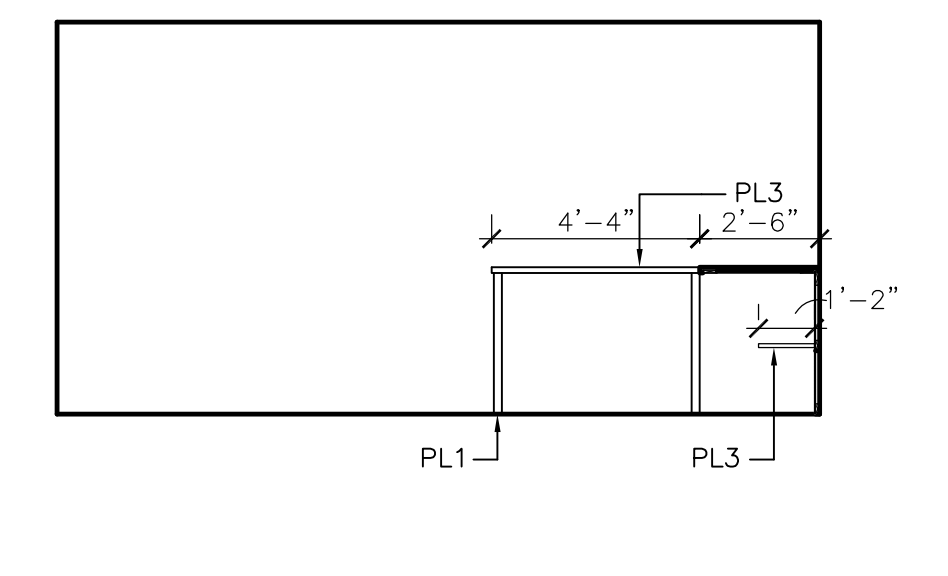

12 PRODUCTION ROOM 207
1/4" = 1'-0"

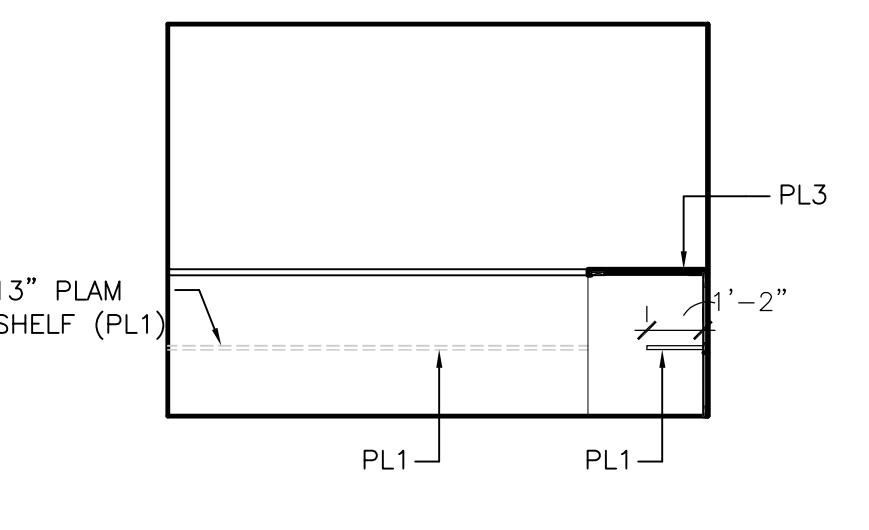

13 PRODUCTION ROOM 207
1/4" = 1'-0"

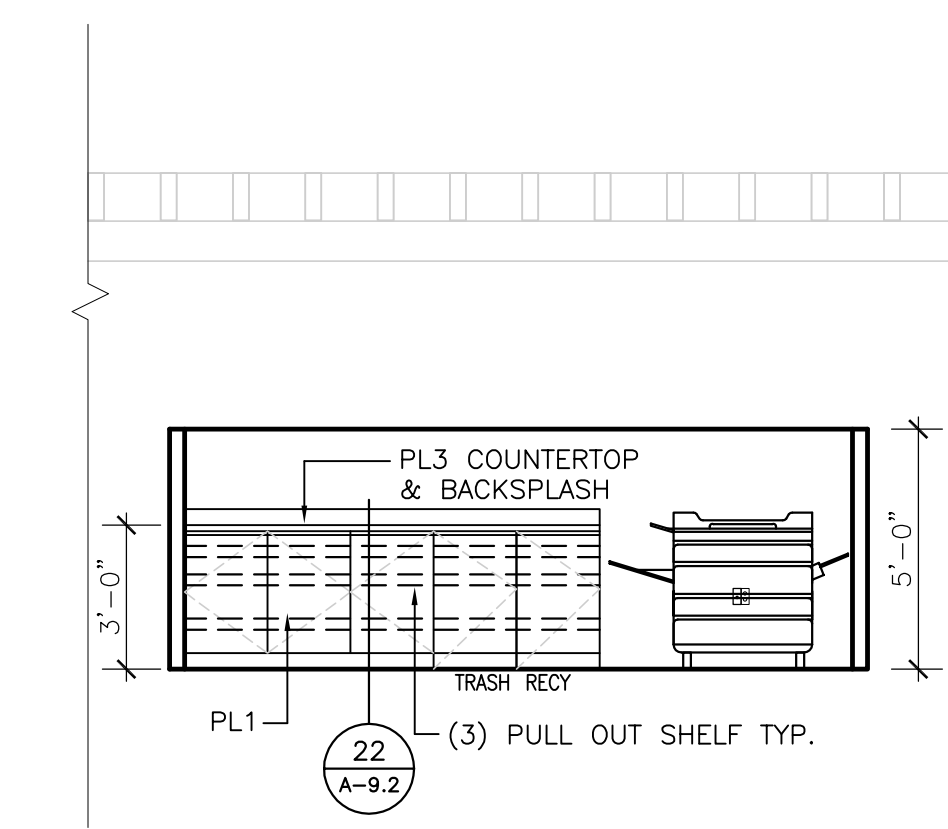

14 COPY 343
1/4" = 1'-0"

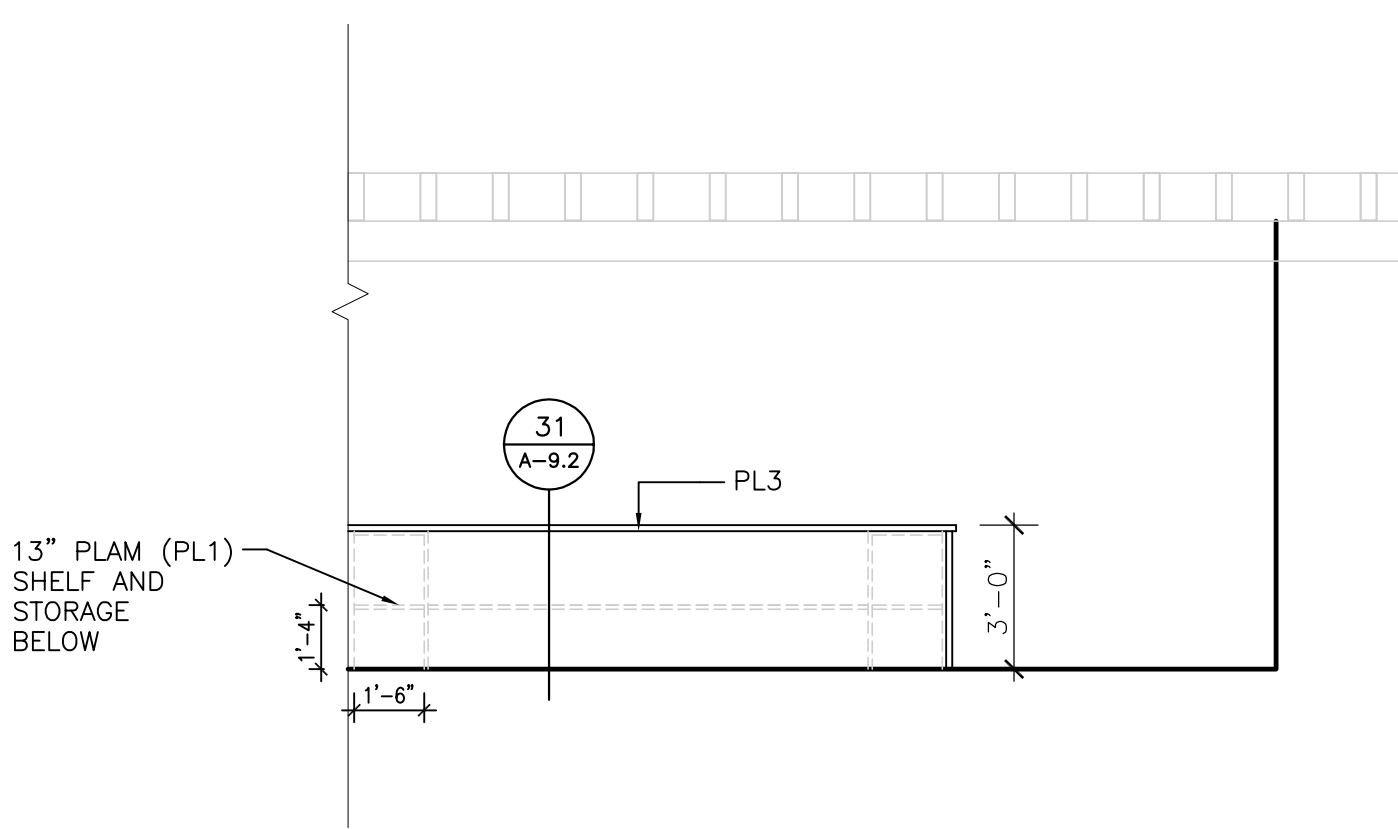

15 OPEN OFFICE 384
1/4" = 1'-0"

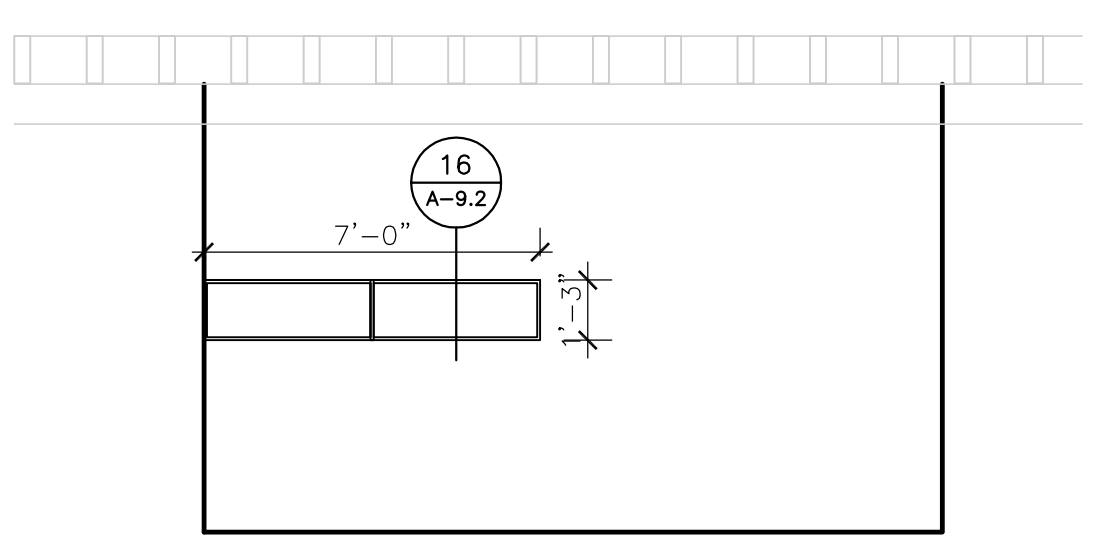

16 TYPICAL OFFICE SHELVING
1/4" = 1'-0"

17 NOT USED
1/4" = 1'-0"

NO.	DATE	REVISION