



Premium Condensing  
Tankless Gas Water Heater

# NPE Series Tankless Water Heaters Specification Sheet

- Certified design according to **ANSI Z21.10.3/CSA 4.3-2011** standards for both indoor or outdoor installations (with optional Outdoor Vent Kit)
- Compatible with **1/2" gas pipe up to a length of 24 ft\*** (\*see Installation Manual for additional information)
- Compatible with **2" PVC vent up to 60 ft\*\*** and **150 ft\*\* using 3" PVC vent** (\*\*with no elbows)
- Gas Input Ranges  
**NPE-180A** - 150,000 to 15,000 BTUh  
**NPE-210A** - 180,000 to 19,900 BTUh  
**NPE-240A** - 199,900 to 19,900 BTUh
- Hot Water Flow Rate Capacity  
**NPE-180A** - 8.4 GPM  
**NPE-210A** - 10.1 GPM  
**NPE-240A** - 11.2 GPM
- **Dual Primary and Secondary Stainless Steel Heat Exchangers** for optimum efficiency and durability
- **Built-in Control Panel** - allows adjustment of temperature settings and displays the operating status and error codes
- **ComfortFLOW™ Technology** - comes included with built-in 0.5 gallon **Buffer Tank** and **Recirculation Pump** to provide maximum comfort
- **INTELLIGENT Preheating** - recognizes hot water usage patterns to intelligently provide hot water when needed
- **Temperature Options** - available temperature settings for Residential applications range from 98°F up to 140°F with high temperature Commercial mode capable of up to 182°F
- **Ready-Link Multi-System** - up to 16 units can be cascaded together for increased hot water production
- **Reduced pressure loss** for maximum hot water output
- **Ease of Maintenance and Service** - allows for quick removal and simple repairs to waterway components such as the pump, water adjustment valve, and 2-way valve.
- **Freeze Protection** activated by the circulation pump to maintain standard operation during freezing ambient temperatures
- Energy Factor  
**NPE-180A** - 0.95 (NG) 0.96 (LPG)  
**NPE-210A** - 0.95 (NG) 0.97 (LPG)  
**NPE-240A** - 0.95 (NG) 0.97 (LPG)
- Compatible with **Natural Gas (NG)** and **Propane (LPG)\*\*\*** (\*\*\*) requires installation of included Field Conversion Kit by a qualified gas servicer)
- Approved for Installations on **Mobile/Manufactured Homes**
- Certified by **CSA, NSF 5, AB1953 CA Low Lead, SCAQMD** (Rule 1146.2 Type 1 - Complies with 14 ng/J or 20 ppm NOx @ 3% O2)
- 15-Year Heat Exchanger Warranty and 5-Year Parts Warranty (see Navien Limited Warranty)
- **Optional accessories** are available (see below)



**Sleek Design - Compatible with 2" PVC Vent and 1/2" Gas Pipe**



**NEW! Built-In Control Panel with Diagnostics**

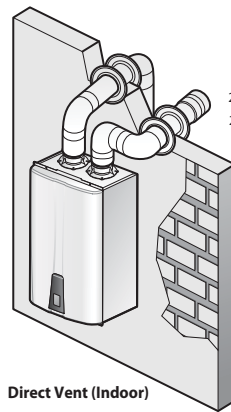

Direct Vent (Indoor)

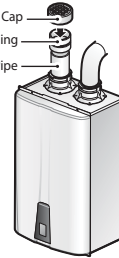

Non-Direct Vent (Indoor)

**Indoor and Outdoor Venting Options**



Non-Direct Vent (Outdoor)



Job Name: \_\_\_\_\_  
 Location: \_\_\_\_\_  
 Engineer: \_\_\_\_\_  
 Wholesaler: \_\_\_\_\_  
 Contractor: \_\_\_\_\_  
 Model No.: \_\_\_\_\_  
 Submitted to: \_\_\_\_\_

<b>Remote Controller</b> NR-20DU (30009757A)	<b>Plumb Easy Valve Set (3/4")</b> (UA0900001A - Standard) (UA0900002A - Lead Free)	<b>Condensate Neutralizer</b> (UA1300001A)	<b>Ready-Link Communication Cable</b> (BCRA1129)	<b>Outdoor Vent Kit</b> (30010605A for NPE-180A) (30010604A for NPE-210A/240A)	<b>3" Vent Termination Caps and Wall Flanges</b> (BH2535006A)

## Dimensions

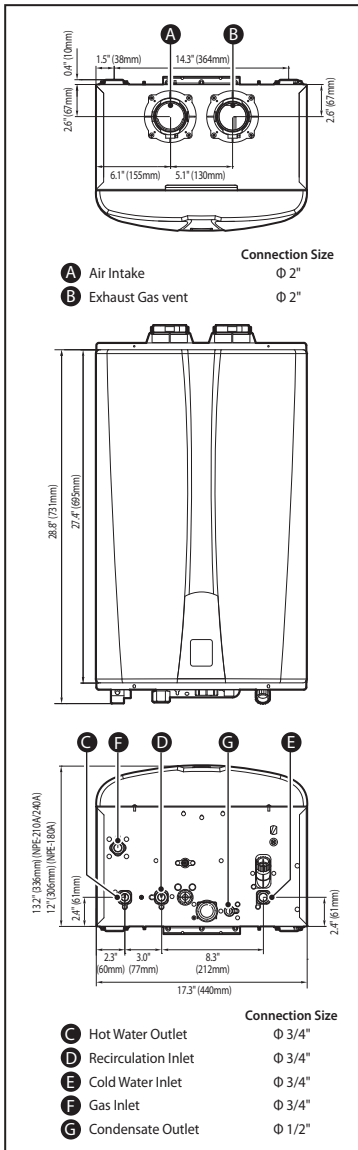

## Specifications

Item		NPE-180A	NPE-210A	NPE-240A
Heat Capacity (Input)	Natural Gas	15,000-150,000 BTU/H	19,900-180,000 BTU/H	19,900-199,900 BTU/H
	Propane Gas	15,000-150,000 BTU/H	19,900-180,000 BTU/H	19,900-199,900 BTU/H
Flow Rate (DHW)	35°F (19°C) Temp Rise	8.4 GPM (32 L/m)	10.1 GPM (38 L/m)	11.2 GPM (42 L/m)
	45°F (25°C) Temp Rise	6.5 GPM (25 L/m)	7.8 GPM (30 L/m)	8.7 GPM (33 L/m)
	77°F (43°C) Temp Rise	3.8 GPM (14 L/m)	4.6 GPM (17 L/m)	5.1 GPM (19 L/m)
Dimensions		17.3"(W) x 27.4"(H) x 11.4"(D)	17.3"(W) x 27.4"(H) x 13.2"(D)	17.3"(W) x 27.4"(H) x 13.2"(D)
Weight		75 lbs (34kg)	82 lbs (37 kg)	82 lbs (37 kg)
Installation Type		Indoor or Outdoor Wall-Hung		
Venting Type		Forced Draft Direct Vent		
Ignition		Electronic Ignition		
Water Pressure		15-150 PSI		
Natural Gas Supply Pressure (from source)		3.5"-10.5" WC		
Propane Gas Supply Pressure (from source)		8"-13" WC		
Natural Gas Manifold Pressure (min to max)		-0.04" WC to -0.84" WC	-0.04" WC to -0.36" WC	-0.04" WC to -0.58" WC
Propane Gas Manifold Pressure (min to max)		-0.03" WC to -0.50" WC	-0.02" WC to -0.66" WC	-0.02" WC to -0.78" WC
Minimum Flow Rate		0 GPM (0 L/m)		
Connection Sizes	Cold Water Inlet	3/4" NPT		
	Hot Water Outlet	3/4" NPT		
	Recirculation Inlet	3/4" NPT		
	Gas Inlet	3/4" NPT		
Power Supply	Main Supply	120V AC, 60Hz		
	Maximum Power Consumption	200W (up to 2 amperes), 350W (up to 4 amperes) with external pump connected		
Materials	Casing	Cold Rolled Carbon Steel		
	Heat Exchangers	Primary Heat Exchanger: Stainless Steel Secondary Heat Exchanger: Stainless Steel		
Venting	Exhaust	2" or 3" PVC, CPVC, Polypropylene 2" or 3" Special Gas Vent Type BH (Class II, A/B/C)		
	Intake	2" or 3" PVC, CPVC, Polypropylene 2" or 3" Special Gas Vent Type BH (Class II, A/B/C)		
	Vent Clearances	0" to Combustibles		
Safety Devices		Flame Rod, APS, Ignition Operation Detector, Water Temperature High Limit Switch, Exhaust Temperature High Limit Sensor, Power Surge Fuse		

Gas-fired, tankless, condensing, wall-mounted water heater(s) shall be direct vent NPE Series models as manufactured by Navien America, Inc. and are certified by CSA International to the latest edition of ANSI standard Z21.10.3/CSA 4.3. Water heater(s) shall have a 15-year limited Heat Exchanger warranty and 5-year limited Parts warranty (10-year Heat Exchanger and 3-year Parts for Commercial use) per Navien Limited Warranty. Unit(s) shall be designed to burn natural gas and can be for use with propane when a Field Conversion Kit is installed. Water heater(s) shall have a nominal flow rate capacity of \_\_\_\_\_ GPM/GPH at \_\_\_\_\_°F rise with rated input of \_\_\_\_\_ BTU/hr. Water heater(s) shall be vented with 2" PVC/CPVC vent pipe at a distance not to exceed 60' (or equivalent) with each elbow equal to 8' of pipe length or 3" PVC/CPVC vent pipe at a distance of 150' (or equivalent) with each elbow equal to 5' of pipe length. Water heater(s) is rated for 150 PSI working water pressure and 300 PSI test pressure. Gas supply pressure shall be 3.5" to 10.5" WC for natural gas and 8.0" to 13.0" WC for propane. Unit(s) shall have a steel case, dual stainless steel heat exchangers, eco premixed burner, negative pressure gas valve, dual venturi, 3/4" inlet gas connection, 3/4" brass inlet/outlet water connections, water holding capacity of 1.0 gallon for the NPE-180A model and 1.2 gallons for the NPE-210A/NPE-240A models, and a condensate collector. The NPE-180A model weighs 75 lbs and the NPE-210A/NPE-240A models weigh 82 lbs. Unit(s) shall include features such as an adjustment for installations at high elevation, temperature lockout, and temperature options from 98-120°F in 1°F intervals and 125-140°F in 5°F intervals. The unit(s) shall include additional temperature options of 150-180°F in 10°F intervals, and 182°F for high temperature commercial applications. All NPE models shall include an internal circulation pump and 0.5 gallon buffer tank. The water heater(s) shall be controlled by an internal circuit board that monitors the inlet and outlet temperatures with installed thermistors, sensing and controlling flow rate to set point temperature with air-fuel ratio controls in order to maintain thermal combustion efficiency. Unit(s) shall include safety features such as flame sensor system, high limit sensors, overheat prevention device, freeze protection mode, and fan motor rotation detector. Multi-system (cascade) applications that require 2 to 16 units shall be installed by connecting the units using cable-only connections (Ready Link). The water heater(s) exceeds the energy efficiency requirements of ASHRAE 90.1-2010 and is listed by SCAQMD rule 1146.2 (Type 1) for Low NOx that complies with 14 ng/J or 20 ppm NOx requirements @ 3% O2.

\*Navien America reserves the right to change specifications at any time without prior notice