

1
P200
SHOWER AT LINEN
1/2" = 1'-0"

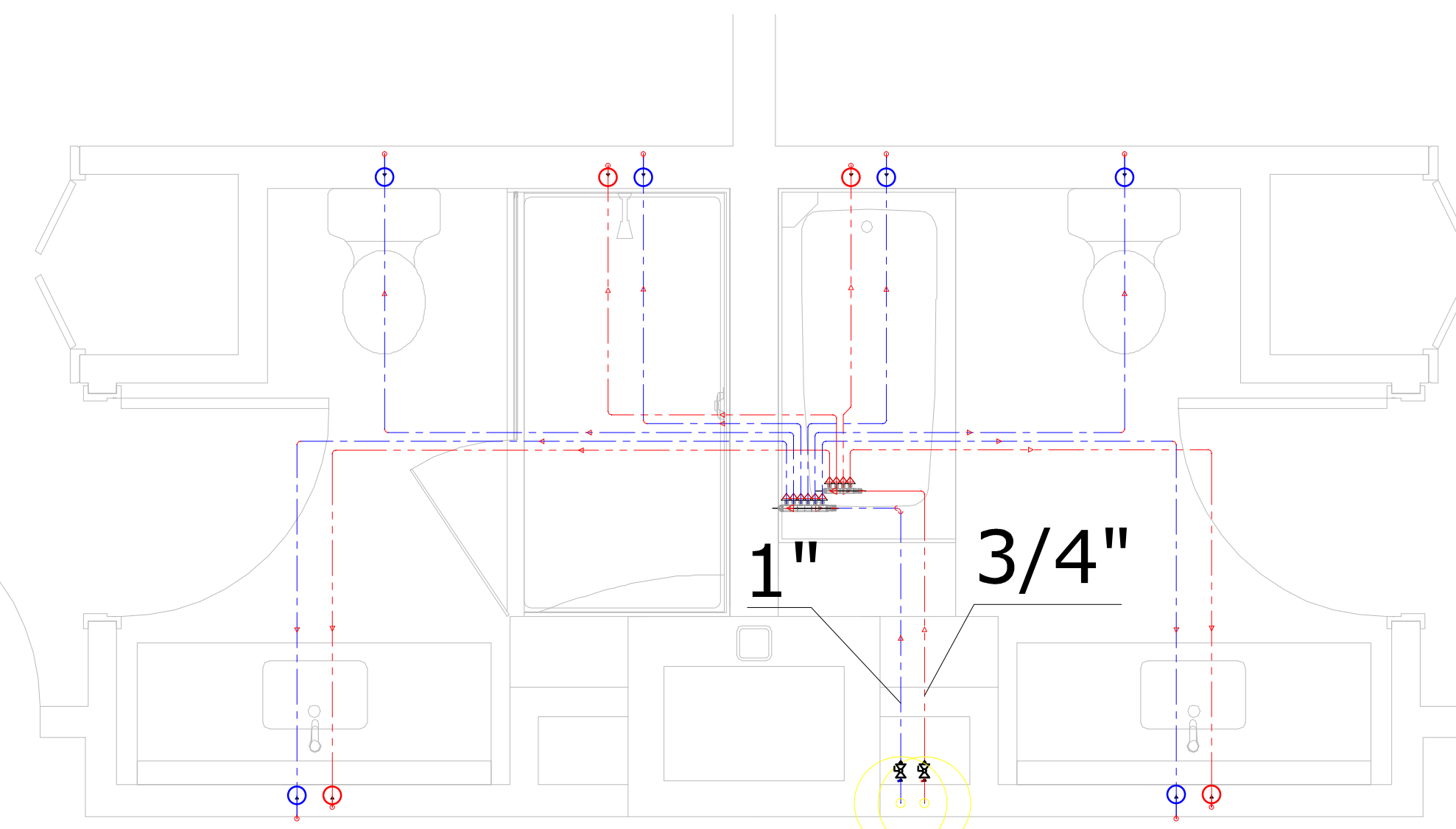

2
P200
TUB/SHOWER
1/2" = 1'-0"

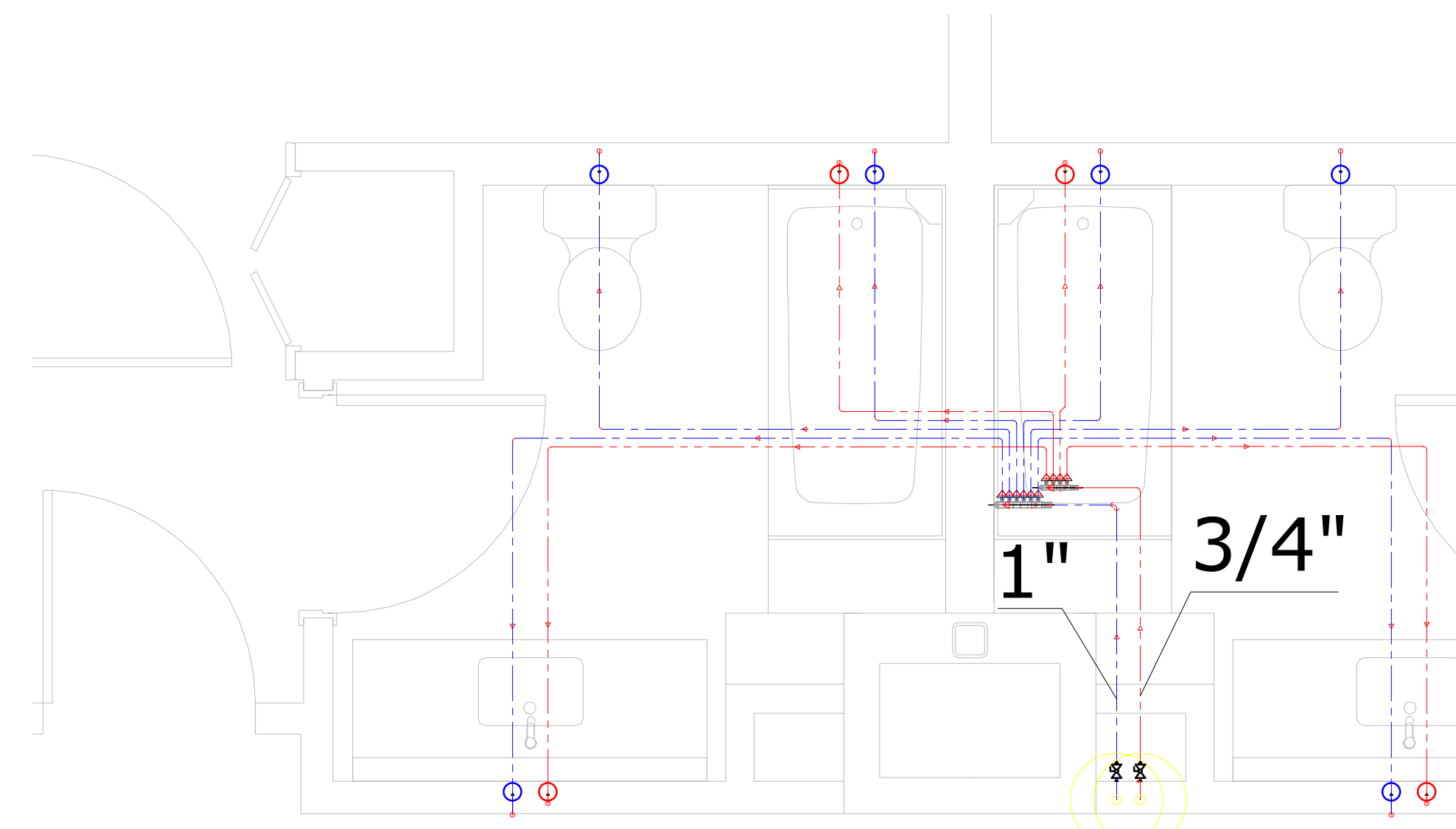

3
P200
TUB/TUB
1/2" = 1'-0"

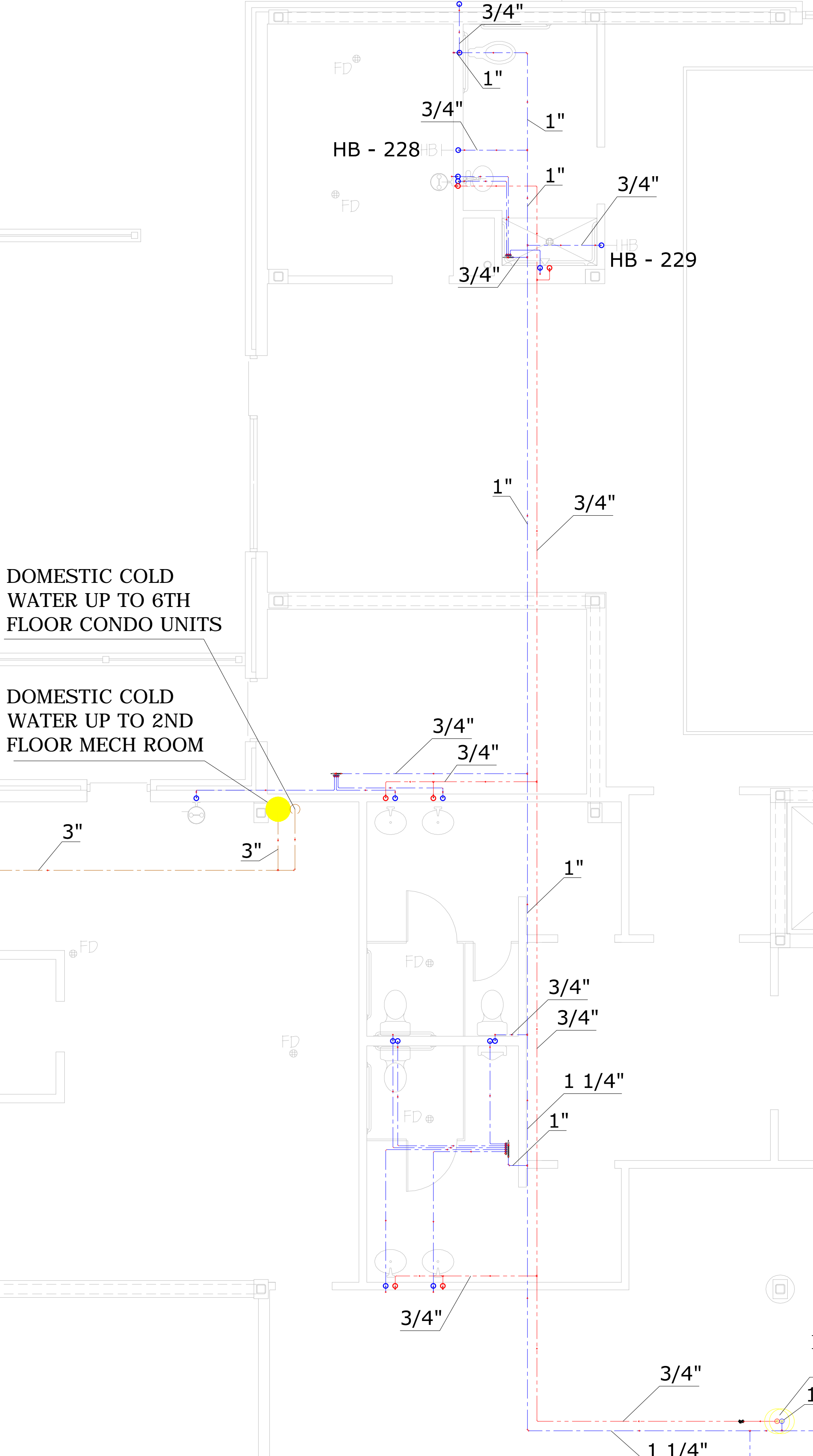

7
P200
1ST FLOOR MAIN
1/4" = 1'-0"

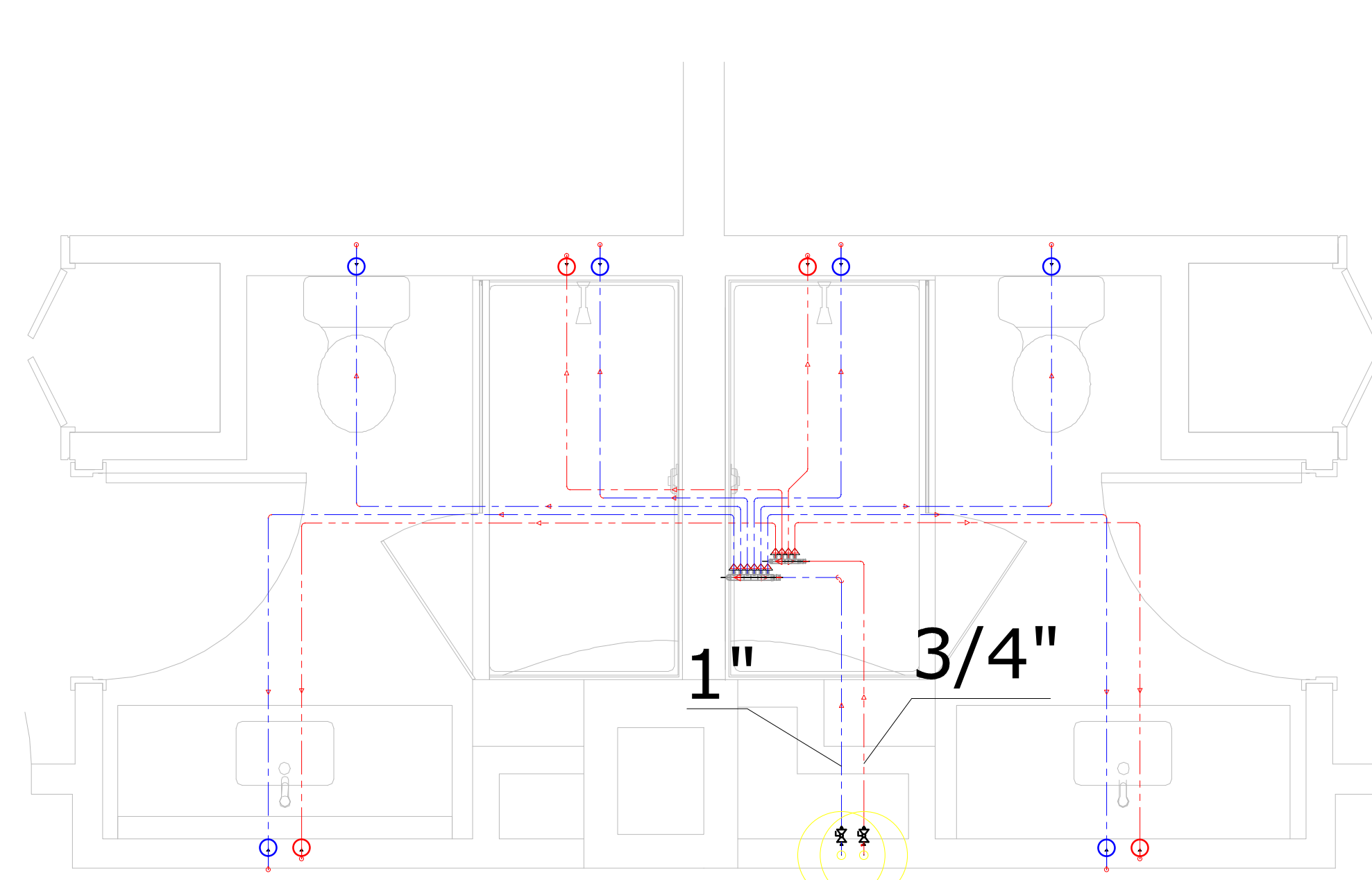

4
P200
SHOWER/SHOWER
1/2" = 1'-0"

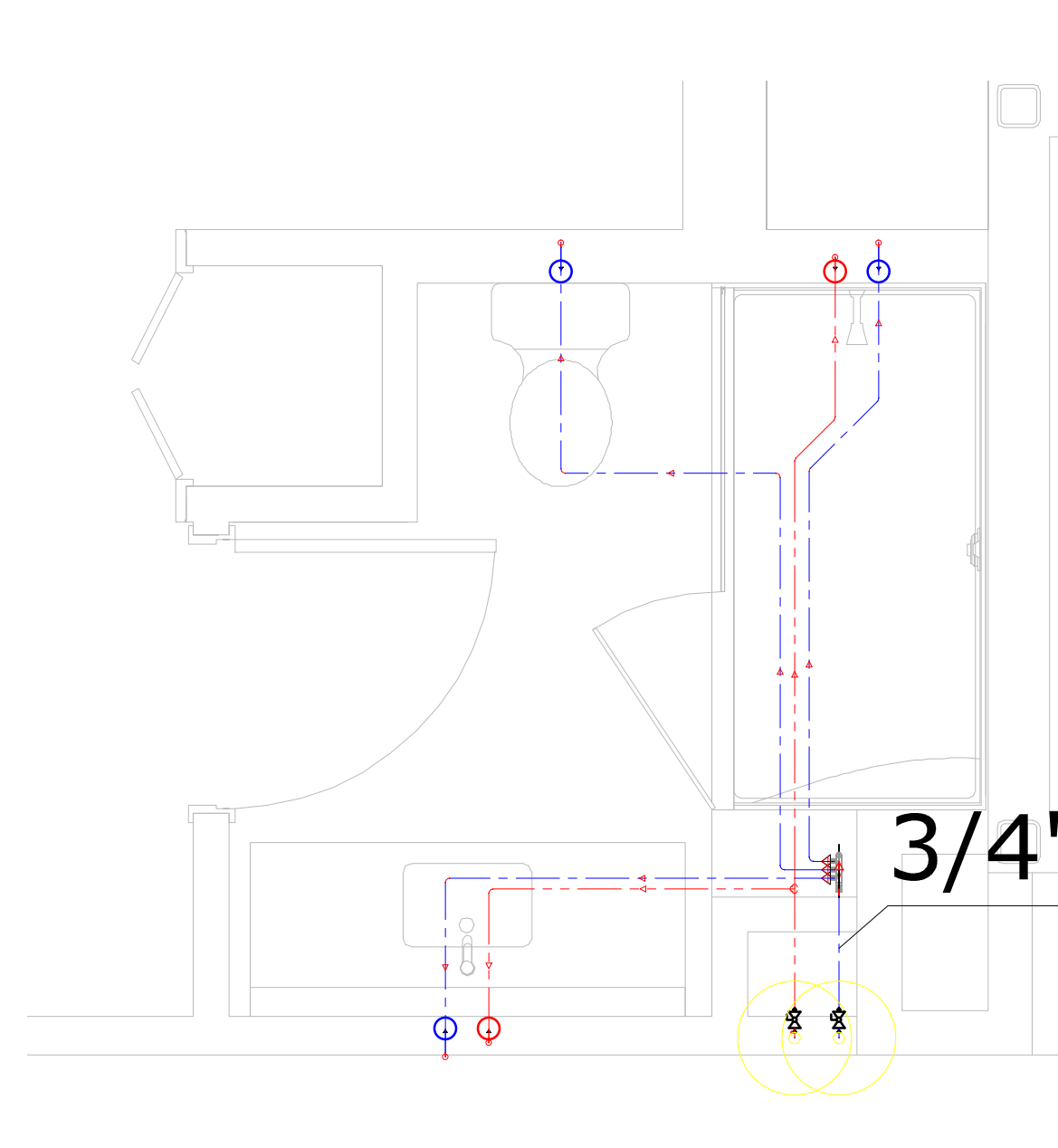

5
P200
SHOWER ONLY
1/2" = 1'-0"

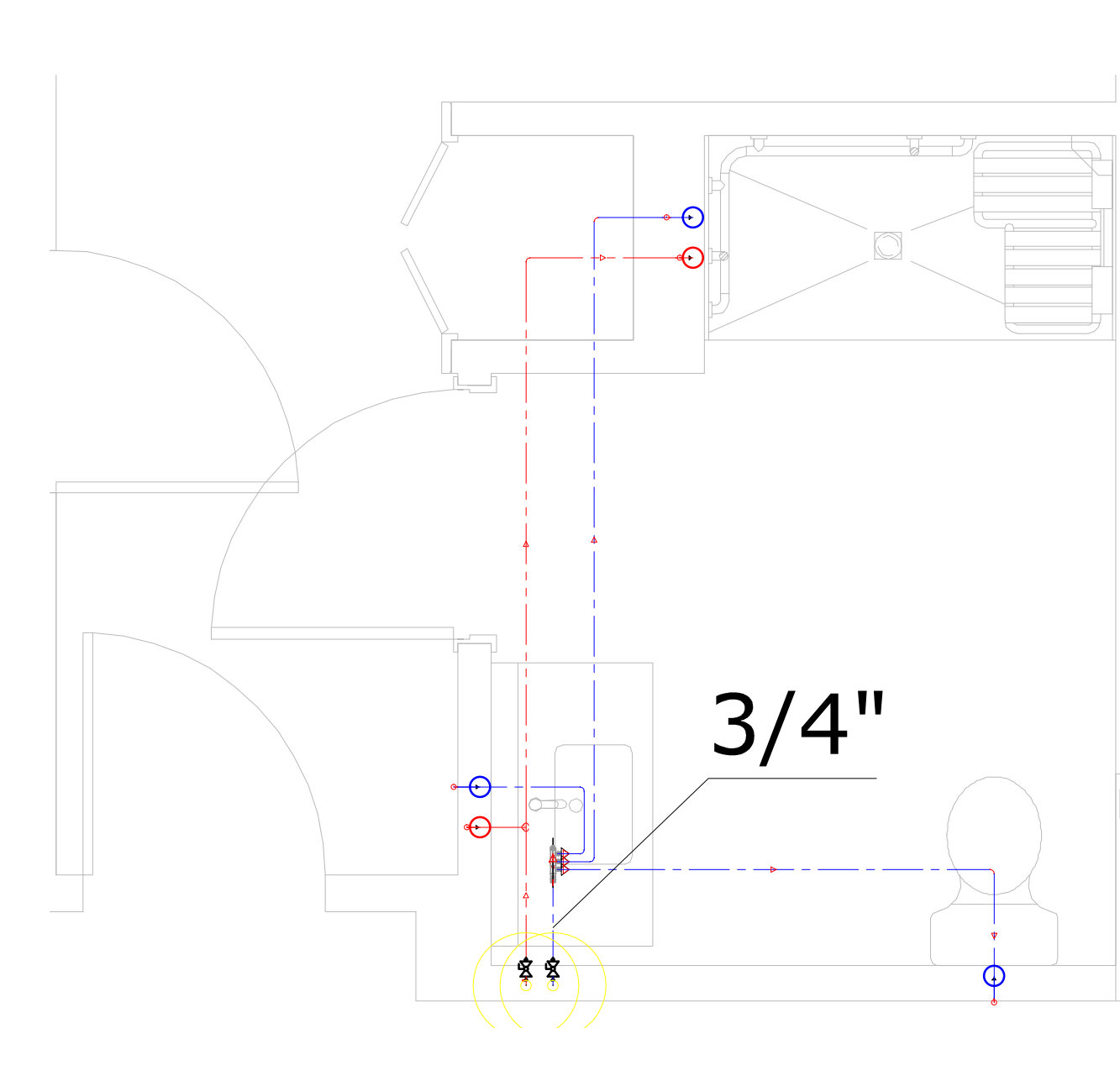

6
P200
ADA SHOWER ONLY
1/2" = 1'-0"

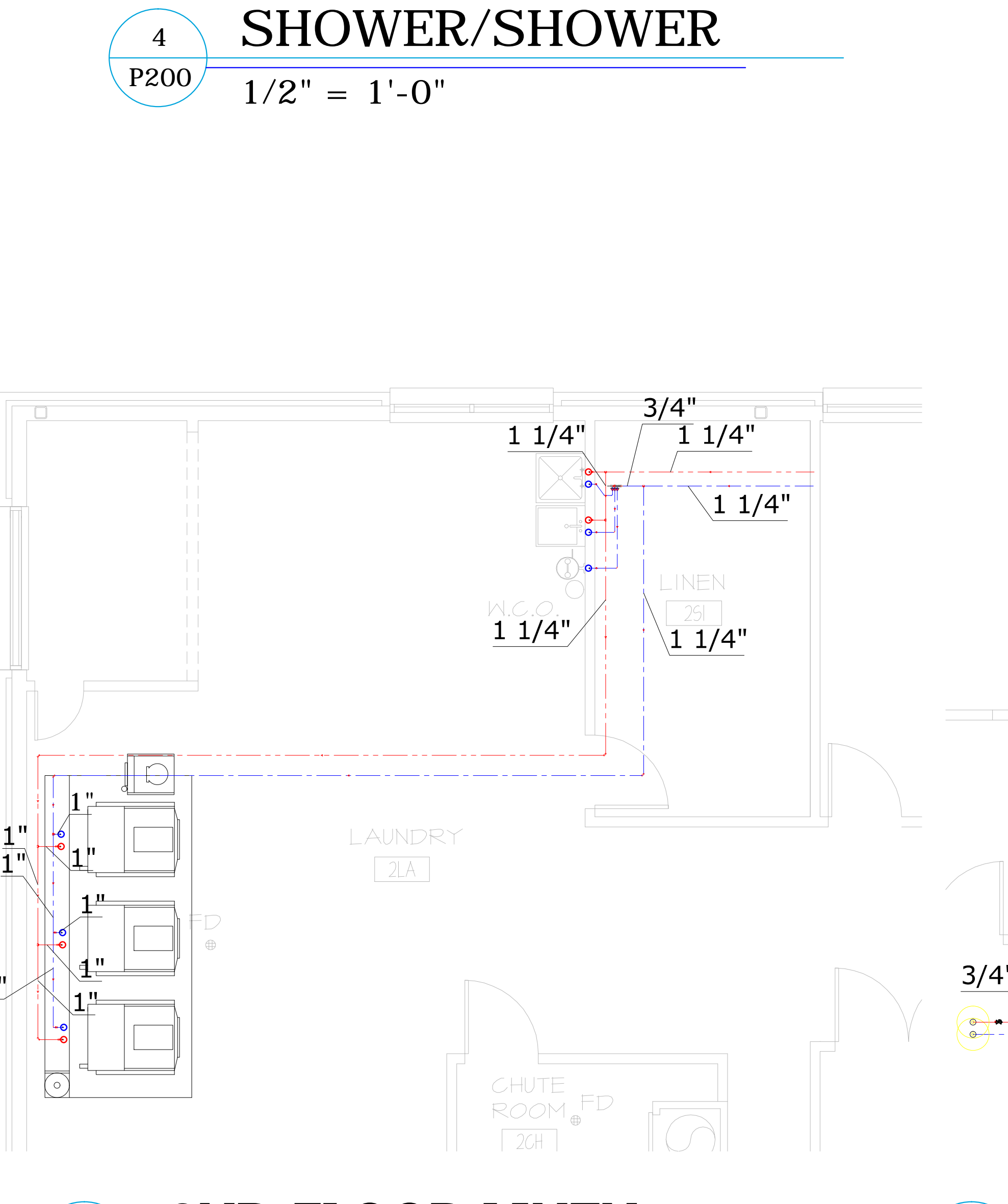

8
P200
2ND FLOOR LINEN
1/4" = 1'-0"

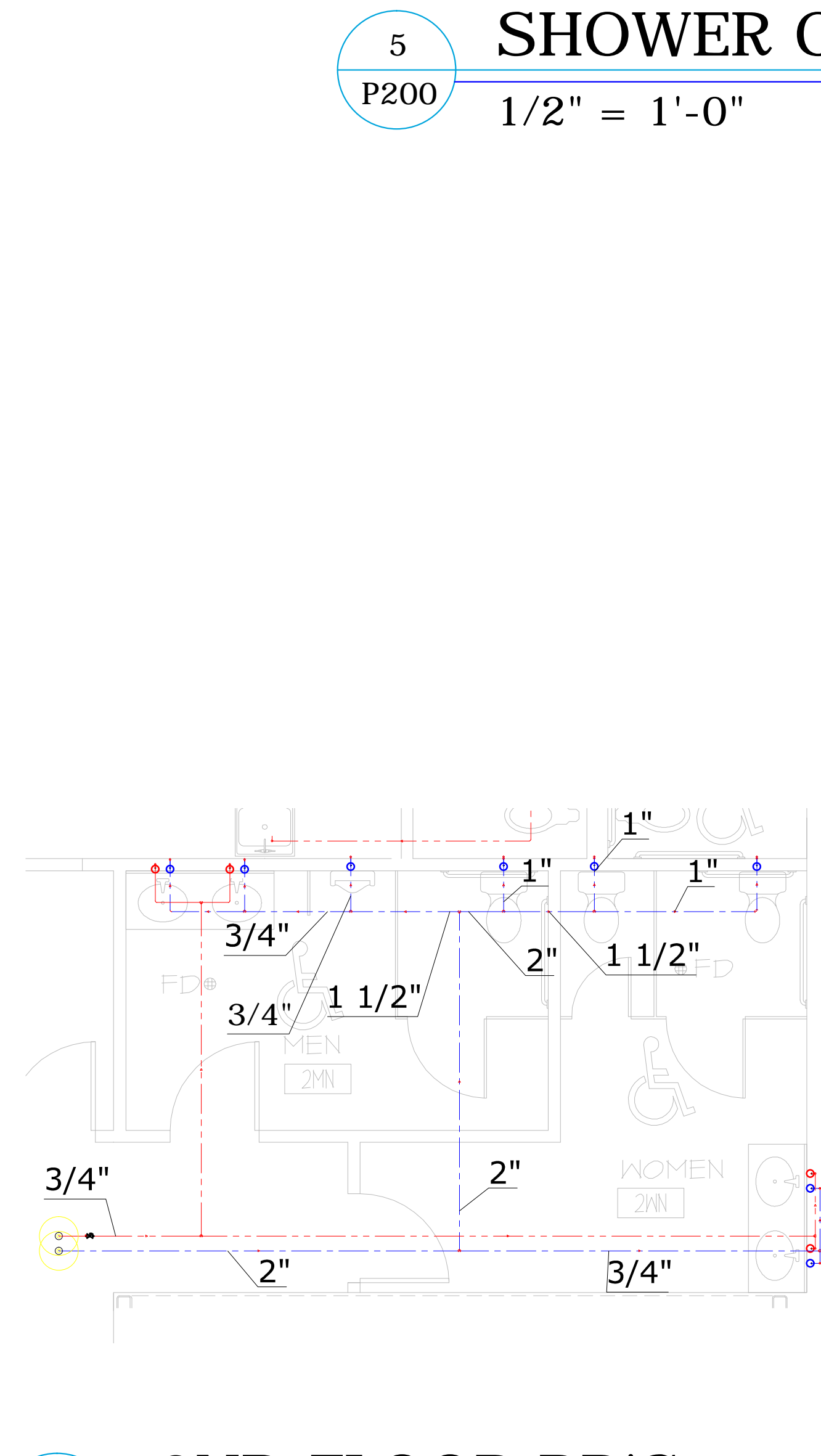

9
P200
2ND FLOOR RR'S
1/4" = 1'-0"

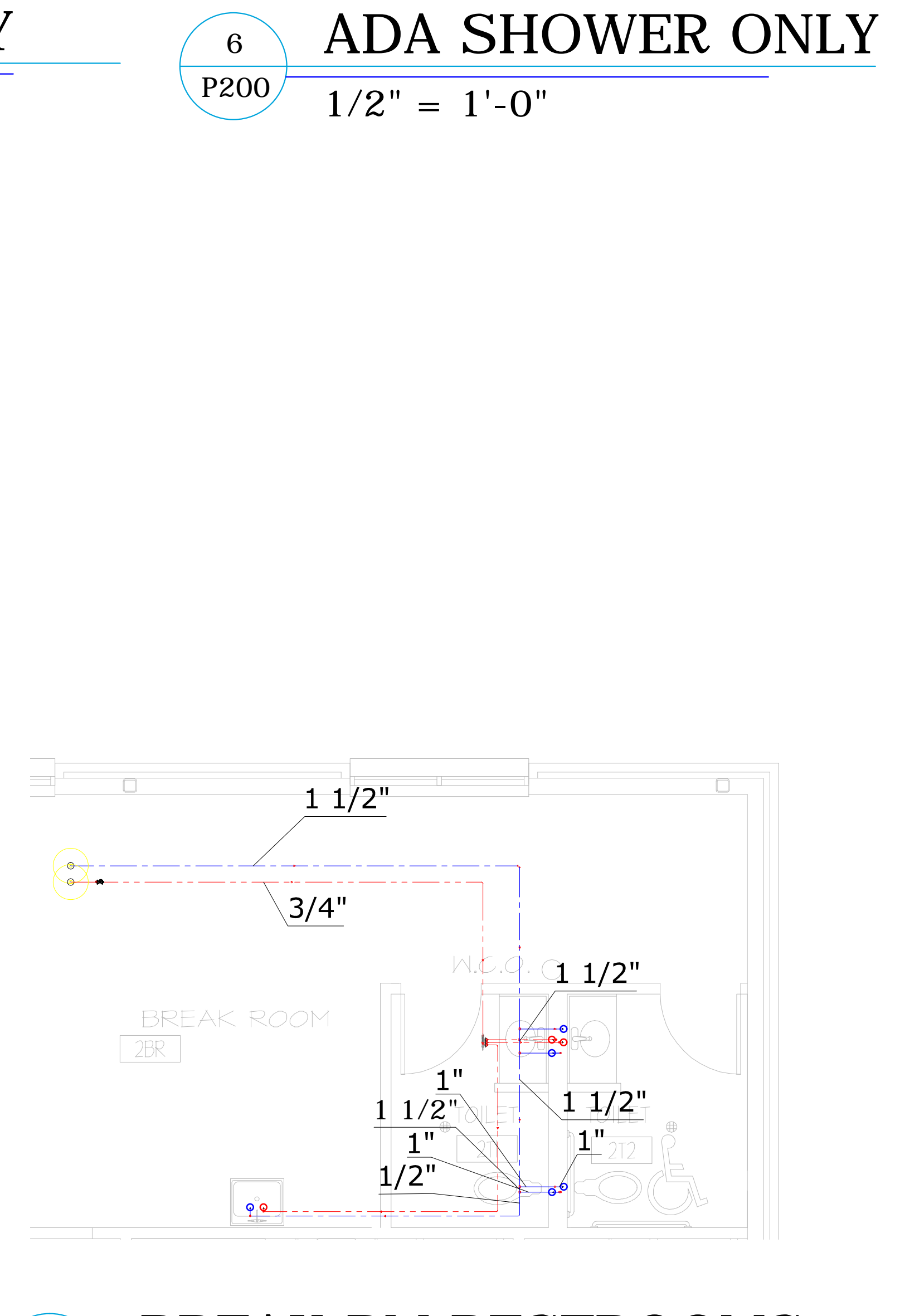

10
P200
BREAK RM RESTROOMS
1/4" = 1'-0"

CLIENT LOGO

STAMP

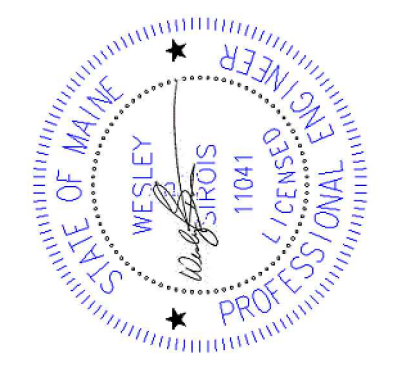

DISCLAIMER
THIS SERIES OF DRAWINGS, INCLUDING ANY AND ALL REVISIONS, AND/OR THE SPINOFF TECHNICAL DRAWINGS HAVE BEEN DESIGNED BY UPONOR, INC. TECHNICAL SERVICES - DESIGN DEPARTMENT. UPONOR, INC. TECHNICAL SERVICES - DESIGN DEPARTMENT ASSUMES NO LIABILITY FOR ANY ERRORS OR OMISSIONS IN THESE DRAWINGS OR FOR ANY DAMAGES THAT MAY RESULT FROM THE APPLICATION AND INTERPRETATION OF THESE DRAWINGS. BEFORE STARTING ALL STANDARDS OF DESIGN AND CONSTRUCTION. BEFORE STARTING ALL WORK, THE CONTRACTOR SHALL VERIFY ALL DIMENSIONS, MATERIALS, PLUMBING AND/OR THE CORRECT USE. REPORT ANY ERRORS AND/OR DISCREPANCIES TO THE DESIGNER IMMEDIATELY. THE DESIGNER SHALL BE RESPONSIBLE FOR THE DESIGN AND THE CONTRACTOR SHALL BE RESPONSIBLE FOR THE INSTALLATION AND THE CONTRACTOR SHALL BE RESPONSIBLE FOR THE TESTING AND THE CONTRACTOR SHALL BE RESPONSIBLE FOR THE MAINTENANCE AND THE CONTRACTOR SHALL BE RESPONSIBLE FOR THE REPAIRS AND THE CONTRACTOR SHALL BE RESPONSIBLE FOR THE REPLACEMENT OF THE FLUSH VALVES.

**MARRIOTT COURTYARD - PORTLAND
COMMERCIAL & MAPLE STREET
PORTLAND, ME**

REVISIONS CONTINUED		NO.	DATE	DESCRIPTION
PROJECT NUMBER	13441.P1			
PROJECT NAME	MARRIOTT COURTYARD - PORTLAND			
PROJECT ADDRESS	COMMERCIAL & MAPLE ST., PORTLAND, ME			
PROJECT DATE	06/13/2013			
SHEET SCALE	VARIABLE			
FINISHES	VARIES			
REVISIONS				
NO.	DATE	DESCRIPTION		
1	06/13/13	REPAIR BY FLUSH VALVES		

SHEET DESCRIPTION
TYPICAL HOTEL UNITS

SHEET NUMBER

C:\Users\jves.RANOR\appdata\local\temp\AcfPublish_8384\Marrriot Portland_Rev2_Uponor.dwg 11/18/13 11:32 am