

NOTE: DETAIL TYPICAL FOR CEILING GRILLES, REGISTERS AND LINEAR DIFFUSERS. FOR SURFACE-MOUNT DEVICES, SUPPORT PLENUM FROM CEILING GRID WITH STEEL ANGLES FASTENED TO PLENUM.

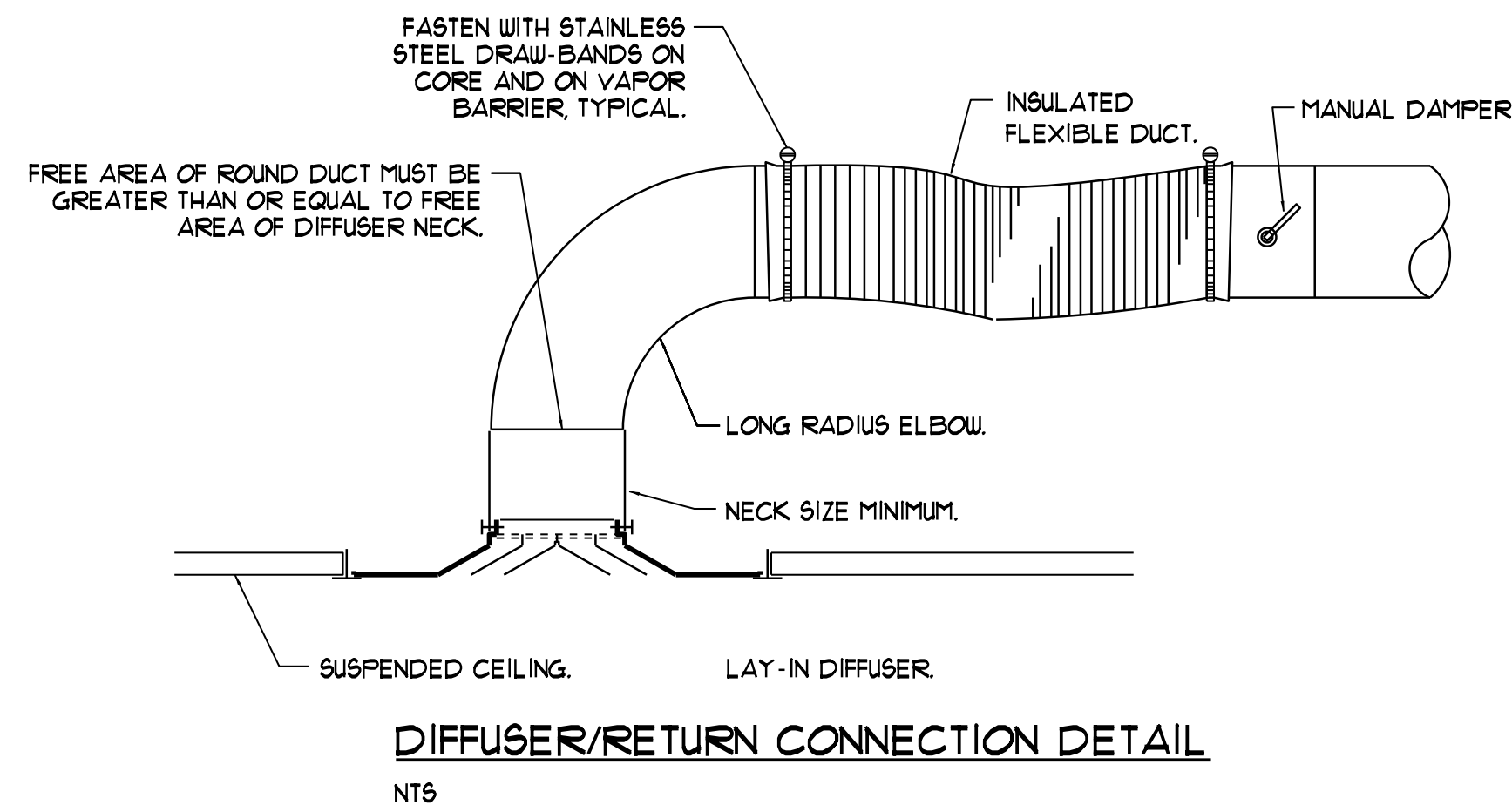

NOTE: DETAIL TYPICAL FOR CEILING GRILLES, REGISTERS AND LINEAR DIFFUSERS. FOR SURFACE-MOUNT DEVICES, SUPPORT PLENUM FROM CEILING GRID WITH STEEL ANGLES FASTENED TO PLENUM. FOR RETURN GRILLES, PROVIDE FLEXIBLE DUCT TO THE PLENUM WHERE INDICATED, 2 FEET LONG MINIMUM, 4 FEET MAXIMUM.

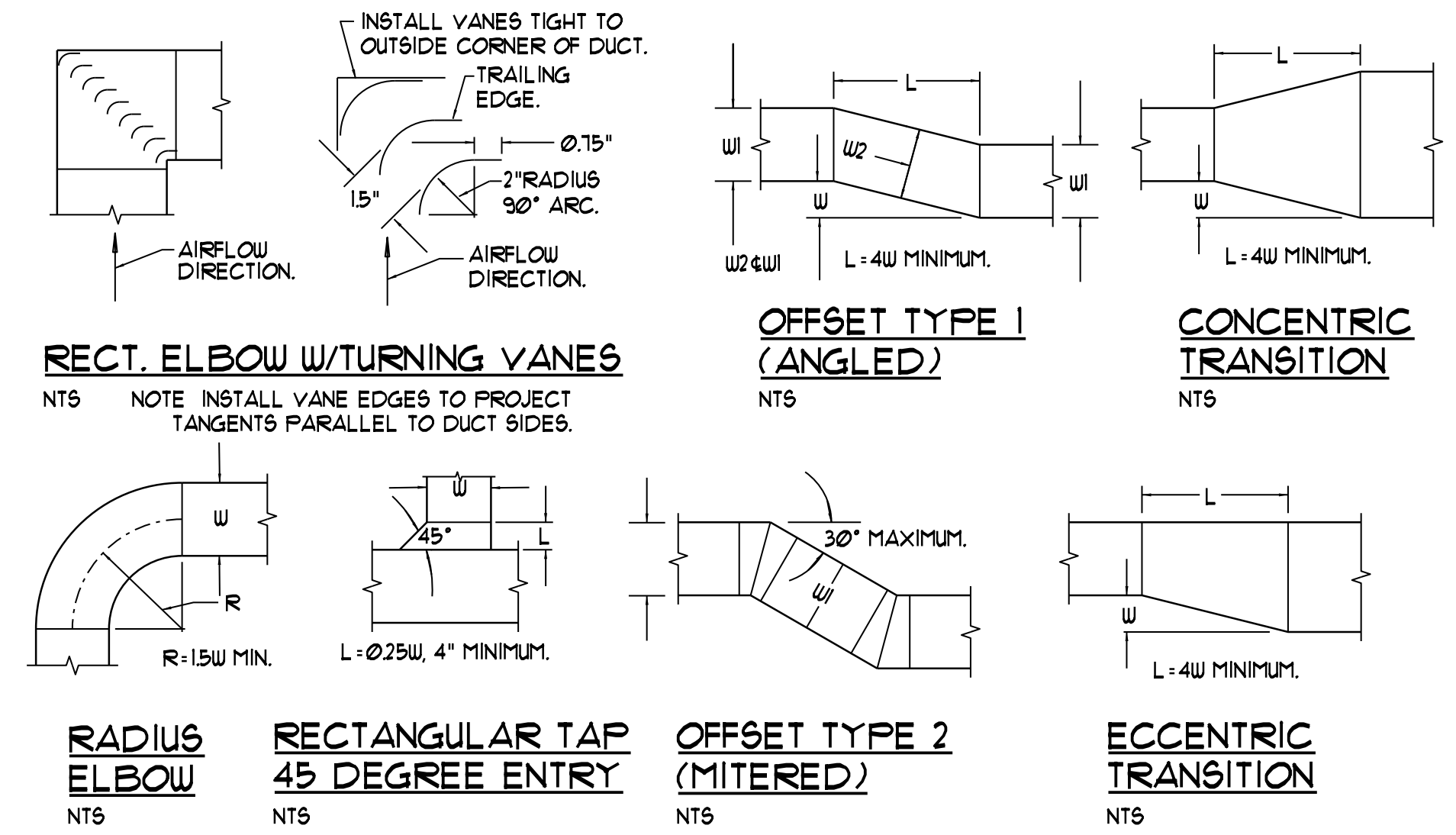
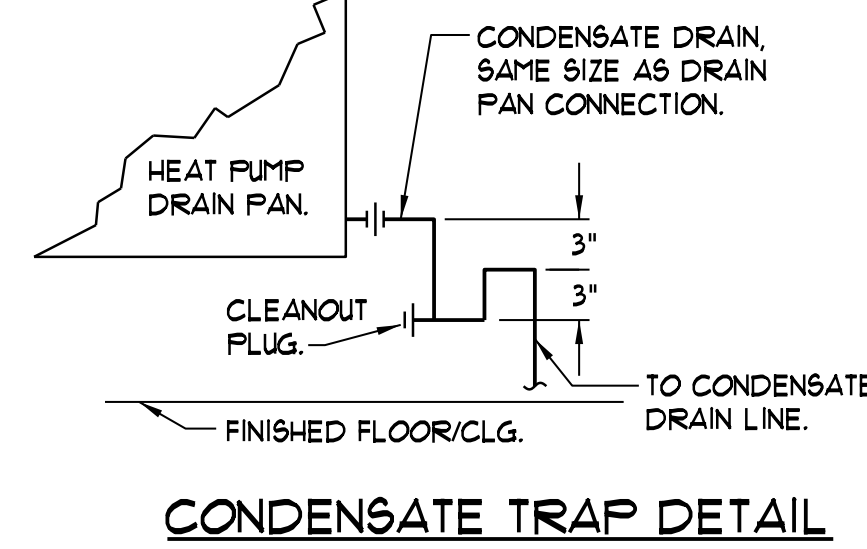

NOTE - CAP UNUSED DRAIN PAN CONNECTIONS.

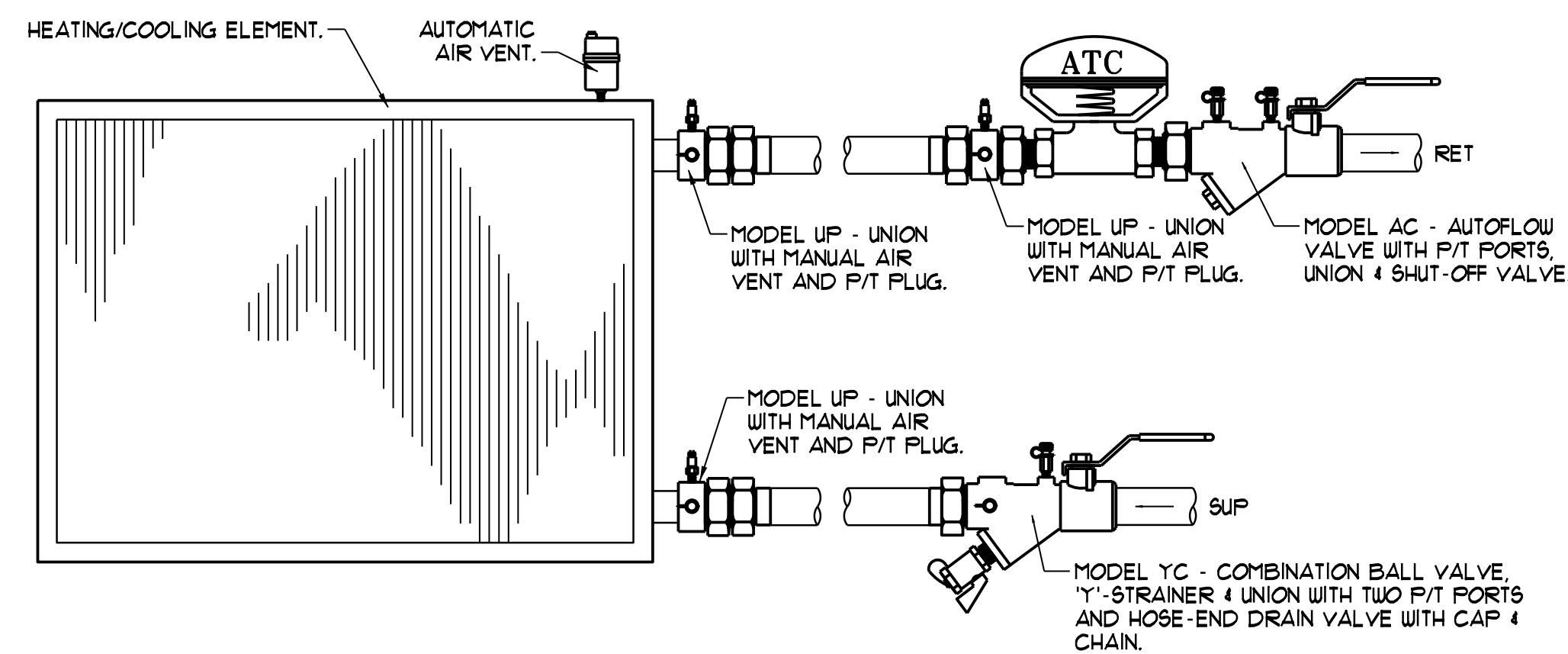
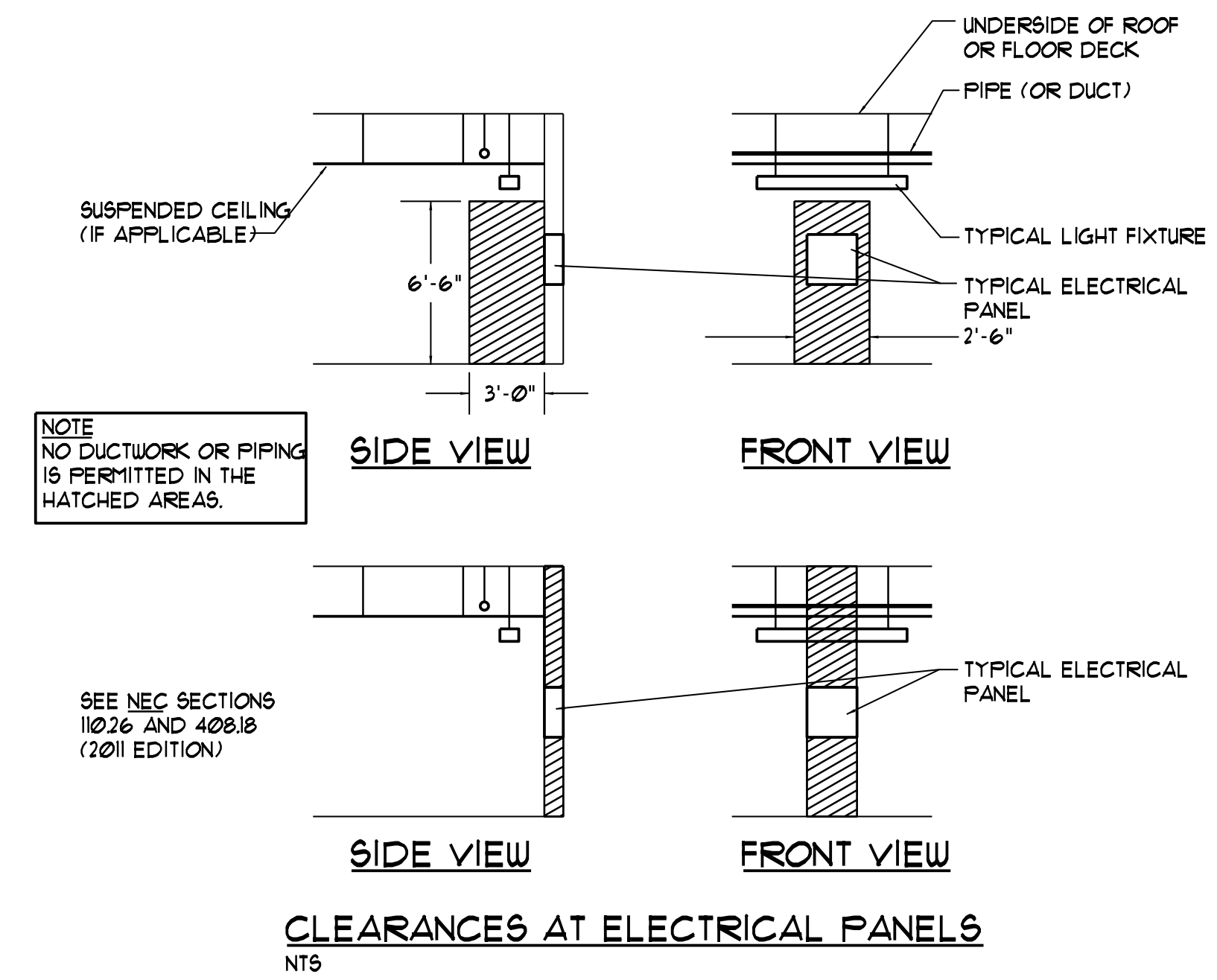

NOTE - MODEL NUMBERS BASED ON FLOW DESIGN INC. FOR PIPE SIZES 2" AND SMALLER.
NOTE - DETAIL APPLIES TO HEAT PUMPS. COORDINATE PIPING COMPONENTS WITH THE HEAT PUMP MANUFACTURER.

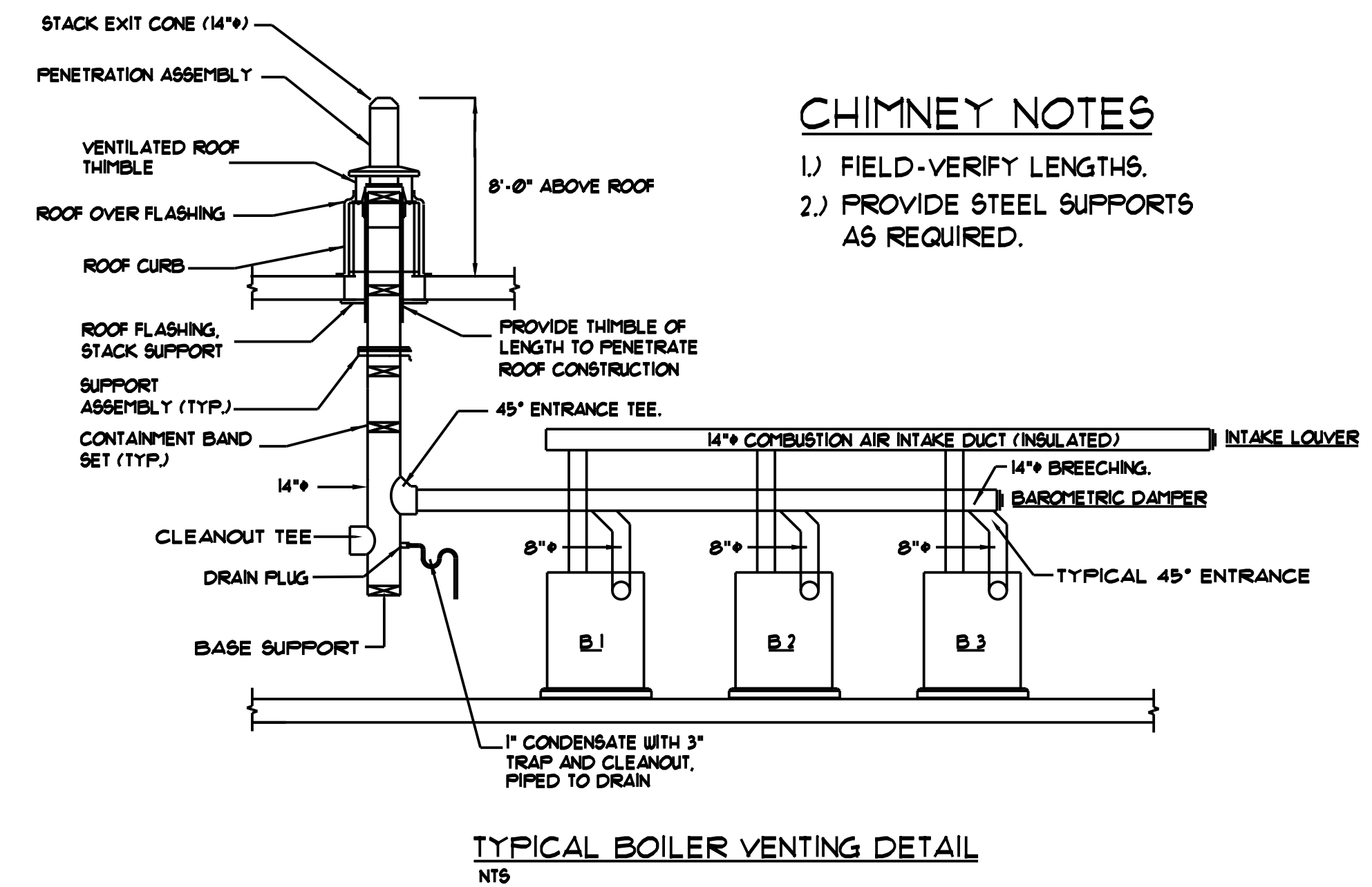

CHIMNEY NOTES

- 1) FIELD-VERIFY LENGTHS.
- 2) PROVIDE STEEL SUPPORTS AS REQUIRED.