

MEANS OF EGRESS - ASSEMBLY OCCUPANCY			
EGRESS COMPONENT	REQUIRED	PROVIDED	CODE REFERENCE
NUMBER OF EXITS	2 PER FLOOR	2 PER FLOOR	IBC TABLE 102.1/NFPA 7.4.1.1
TRAVEL DISTANCE	250' MAX.	<250'	NFPA 101-2009 TABLE A1.6
COMMON PATH OF TRAVEL	20'/75' MAX.	<20'	NFPA 101-2009 TABLE A1.6
DEAD END CORRIDOR	20' MAX.	<20'	NFPA 101-2009 TABLE A1.6
CORRIDOR WIDTH	44" MIN.	60"	IBC 1005.1/NFPA 12.2.3.8
EGRESS DOOR WIDTH	36"	36"	IBC 1005.1/NFPA 12.1.2.4(1)
EGRESS STAIR WIDTH	44" MIN.	50"	IBC 1005.1/NFPA 12.2.2.1.2(B)

MEANS OF EGRESS - RESIDENTIAL OCCUPANCY			
EGRESS COMPONENT	REQUIRED	PROVIDED	CODE REFERENCE
NUMBER OF EXITS	2 PER FLOOR	2 PER FLOOR	IBC TABLE 102.1/NFPA 7.4.1.1
TRAVEL DISTANCE	225' MAX.	<225'	NFPA 101-2009 TABLE A1.6
200' MAX FROM APT. OR HOTEL ROOM ENTRANCE DOOR TO EXIT			NFPA 101-20.2.6.3.3.1 & 30.2.6.3.2
COMMON PATH OF TRAVEL	50' MAX.	<50'	NFPA 101-2009 TABLE A1.6
DEAD END CORRIDOR	50' MAX.	<50'	NFPA 101-2009 TABLE A1.6
CORRIDOR WIDTH	44" MIN.	60"	IBC 1005.1/NFPA 30.2.3.3
EGRESS DOOR WIDTH	36"	36"	IBC 1005.1/NFPA 12.1.2.4(1)
EGRESS STAIR WIDTH	44" MIN.	50"	IBC 1005.1/NFPA 12.2.2.1.2(B)

FIRE RESISTANCE RATINGS FOR BUILDING ELEMENTS-IBC TABLE 601			
TYPE IA CONSTRUCTION - FLOOR 1			
BUILDING ELEMENT	REQUIRED	PROVIDED	
STRUCTURAL FRAME	3	3	
BEARING WALLS			
EXTERIOR	3	N/A	
INTERIOR	3	N/A	
NONBEARING WALLS			
EXTERIOR	0	N/A	
INTERIOR	0	N/A	
FLOOR CONSTRUCTION	2	SLAB ON GRADE	
ROOF CONSTRUCTION	1 1/2	HORIZ. SEPARATION-3HRS.	

FIRE RESISTANCE RATINGS FOR BUILDING ELEMENTS-IBC TABLE 601			
TYPE IIB CONSTRUCTION - FLOORS 2, 3, 4, 5 & 6			
BUILDING ELEMENT	REQUIRED	PROVIDED	
STRUCTURAL FRAME	0	0	
BEARING WALLS			
EXTERIOR	0	N/A	
INTERIOR	0	N/A	
NONBEARING WALLS			
EXTERIOR	0	N/A	
INTERIOR	0	N/A	
FLOOR CONSTRUCTION	0	0	
ROOF CONSTRUCTION	0	0	

INTERIOR FINISH REQUIREMENTS (IBC TABLE 803.4)			
USE GROUP	VERTICAL EXITS AND EXIT PASSAGEWAYS	EXIT ACCESS CORRIDORS AND OTHER EXITS	ROOMS AND ENCLOSED SPACES
A2-RESTAURANTS	B	B	C
A3-MEETING ROOM	B	B	C
R1-HOTEL	B	C	C
R2-APARTMENTS	C	C	C

HALL AND CEILING FINISHES SHALL BE TESTED IN ACCORDANCE WITH ASTM E 84 CLASS A. FLAME SPREAD 0-25, SMOKE-DEVELOPMENT 0-450.  
 CLASS B. FLAME SPREAD 26-75, SMOKE-DEVELOPMENT 0-450.  
 CLASS C. FLAME SPREAD 76-200, SMOKE-DEVELOPMENT 0-600.  
 DECORATIVE MATERIALS SHALL MEET NFPA 701 IN ACCORDANCE WITH IBC SECTION 806.2 OR BE NONCOMBUSTIBLE.  
 DECORATIVE TRIM SHALL MEET IBC SECTION 806.5.  
 NOTE: INTERIOR FLOOR FINISHES IN VERTICAL EXITS, EXIT PASSAGEWAYS AND EXIT ACCESS CORRIDORS SHALL BE CLASS II AS CLASSIFIED PER NFPA 253 AND TESTED IN ACCORDANCE WITH ASTM E 648.

GYPSUM BOARD MATERIALS AND ACCESSORIES SHALL COMPLY WITH THE FOLLOWING:	
ACCESSORIES FOR GYPSUM BOARD	ASTM C 1047
ADHESIVES FOR FASTENING GYPSUM WALLBOARD	ASTM C 557
EXTERIOR SOFFIT BOARD	ASTM C 491
FIBER-REINFORCED GYPSUM PANEL	ASTM C 1278
GLASS MAT GYPSUM BACKING PANEL	ASTM C 1178
GLASS MAT GYPSUM SUBSTRATE	ASTM C 1177
GYPSUM BACKING BOARD AND GYPSUM SHAFTLINER BOARD	ASTM C 442
GYPSUM CEILING BOARD	ASTM C 1345
GYPSUM SHEATHING	ASTM C 71
GYPSUM WALLBOARD	ASTM C 36
JOINT REINFORCING TAPE AND COMPOUND	ASTM C 474, C 475
STEEL SCREWS	ASTM C 454, C 1002
STEEL STUDS, NONLOAD BEARING	ASTM C 645
STANDARD SPECIFICATION FOR GYPSUM BOARD	ASTM C 1396
TESTING GYPSUM AND GYPSUM PRODUCTS	ASTM C 22, C 472, C 473
WATER-RESISTANT GYPSUM BACKING BOARD	ASTM C 630

GYPSUM BOARD MATERIALS AND ACCESSORIES SHALL BE INSTALLED IN ACCORDANCE WITH THE FOLLOWING:	
GYPSUM BOARD	6A-216; ASTM C 840
GYPSUM SHEATHING	ASTM C 1280
STEEL FRAMING FOR GYPSUM BOARDS	ASTM C 754, C 1007

OCCUPANT LOAD BY FLOOR  
 NFPA TABLE 7.3.1.2

FLOOR LEVEL	AREA	OCCUPANCY	FLOOR AREA	S.F./PERSON	OCCUPANT LOAD (CALCULATED)	OCCUPANT LOAD (ACTUAL)	TOTAL/FLOOR (ACTUAL)
FIRST FLOOR	BUSINESS AREAS	BUSINESS (ACCESSORY)	452	100 GROSS	4.5	4	135
	LOBBY	ASSEMBLY	3,020	15 NET	201	50	
	SWIMMING POOL-WATER	ASSEMBLY	275	50 NET	5.5	6	
	SWIMMING POOL-DECK	ASSEMBLY	994	30 NET	33	33	
	HOTEL RESTAURANT	ASSEMBLY	1,414	15 NET	94	42 SEATS	
RESTAURANT-(PROPOSED)	ASSEMBLY	4,485	15 NET	299	299		
SECOND FLOOR	HOTEL	RESIDENTIAL	17,488	200 GROSS	88	70	173
	MEETING ROOM	A-3 (ACCESSORY)	1,276	15 NET	85	85	
THIRD FLOOR	HOTEL	RESIDENTIAL	18,760	200 GROSS	94	80	94
FOURTH FLOOR	HOTEL	RESIDENTIAL	18,760	200 GROSS	94	80	94
FIFTH FLOOR	HOTEL	RESIDENTIAL	18,760	200 GROSS	94	80	94
FIFTH FLOOR	APARTMENTS	RESIDENTIAL	18,760	200 GROSS	94	80	94

PLUMBING FIXTURE REQUIREMENTS

MAINE STATE PLUMBING CODE-2009 UPC Table 4-1

USE GROUP	FLOOR LEVEL	OCCUPANT LOAD	WATER CLOSETS			LAVATORIES			DRINKING FOUNTAINS		SERVICE SINK
			RATIO	M	RATIO	W	RATIO	M	W	RATIO	
UNFINISHED SPACE	1	----	----	----	----	----	----	----	----	----	
A-2 HOTEL CAFE/LOUNGE	1	80 SEATS	1 PER 50	1 WC & 1 UR REQUIRED	1 PER 50	2 WC REQUIRED	1 PER 150-M 1 PER 150-W	1 REQUIRED @ EACH	0 REQUIRED	----	1 PER BUILDING
MEETING ROOMS	2	121 PEOPLE	1 PER 100	1 WC & 1 UR REQUIRED	SAME AS MALES (NOTE 14)	2 WC REQUIRED	1 PER 200-M 1 PER 200-W	1 REQUIRED @ EACH	1/150	1 REQUIRED	
R-1 & R-2 RESIDENTIAL	2-6	--	1 PER UNIT				1 PER UNIT		--	--	1 KITCHEN SINK PER APARTMENT

BUILDING INFORMATION

APPLICABLE CODES INCLUDE BUT ARE NOT LIMITED TO THE FOLLOWING:  
 MAINE UNIFORM BUILDING AND ENERGY CODES-COMMERCIAL BUILDING CODE  
 INTERNATIONAL BUILDING CODE 2009  
 NFPA 101 LIFE SAFETY CODE 2009  
 AMERICANS WITH DISABILITIES ACT ARCHITECTURAL GUIDELINES (ADAAG) (CG/ANSI A117.1-2003)  
 MAINE HUMAN RIGHTS LAWS  
 MAINE STATE PLUMBING CODE-LATEST EDITION  
 NATIONAL ELECTRIC CODE-LATEST EDITION  
 ALL LOCAL, STATE AND FEDERAL CODES

USE GROUPS: IBC- R-1 HOTEL, FLOORS 2-5  
 R-2 APARTMENTS, FLOOR 6  
 A-2 RESTAURANTS/HOTEL LOBBY, FLOOR 1  
 A-3 MEETING ROOM (ACCESSORY USE TO HOTEL), FLOOR 2

NFPA 101- RESIDENTIAL-HOTEL  
 RESIDENTIAL-APARTMENTS  
 ASSEMBLY-RESTAURANTS  
 ASSEMBLY-MEETING ROOM

GENERAL HEIGHT AND AREA LIMITATIONS (SECTION 503):

FLOOR 1: USE GROUP A-2 RESTAURANTS/LOBBY  
 CONSTRUCTION TYPE-IA  
 HEIGHT: UNLIMITED HEIGHT & NUMBER OF STORIES  
 AREA ALLOWED: UNLIMITED

FLOORS 2-5: USE GROUP R-1 HOTEL  
 CONSTRUCTION TYPE-IB  
 HEIGHT: 55 FEET, 4 STORIES  
 AREA ALLOWED: 16,000 SF

FLOOR 6: USE GROUP R-2 APARTMENTS  
 CONSTRUCTION TYPE-IB  
 HEIGHT: 55 FEET, 4 STORIES  
 AREA ALLOWED: 16,000 SF

THIS BUILDING IS DESIGNED UTILIZING THE HORIZONTAL BUILDING SEPARATION ALLOWANCE IN IBC 2009 SECTION 504.2. THE FIRST AND SECOND FLOORS ARE SEPARATED BY A 3 HOUR HORIZONTAL ASSEMBLY AND THE STRUCTURE OF THE FIRST FLOOR IS DESIGNED TO MEET THE REQUIREMENTS FOR TYPE IA CONSTRUCTION. THE UPPER 5 FLOORS ARE DESIGNED FOR TYPE IIB CONSTRUCTION AS ALLOWED BY SECTION 503 AND MODIFICATIONS ALLOWED BY SECTION 506.

HEIGHT MODIFICATIONS (SECTION 504.2):

ADD ONE STORY AND 20 FEET (EQUIPPED WITH NFPA 13 AUTOMATIC SPRINKLER SYSTEM)

TOTAL ALLOWABLE HEIGHT: 5 STORIES - 75 FEET

AREA MODIFICATIONS (SECTION 506-EQUATION 5-1):

INCREASE ALLOWABLE AREA BY 25 PERCENT (EQUIPPED WITH NFPA 13 AUTOMATIC SPRINKLER SYSTEM)

-15% FRONTAGE INCREASE

-200% SPRINKLER INCREASE

TOTAL ALLOWABLE FLOOR AREA CALCULATION:

FIRST FLOOR: UNLIMITED

FLOORS 2-6: 16,000 SF + (16,000 SF/FLOOR X 275%)=60,000 SF

TOTAL BUILDING AREA ALLOWED: (IBC SECTION 506.4.1-2)

FLOORS 2-6: 60,000 SF X 3=180,000 SF

FIRE SPRINKLER SYSTEM (SECTION 903):

TYPE: LIGHT HAZARD IN ACCORDANCE WITH NFPA 13

CLASS 1 STANDPIPE SYSTEM-IBC 905.3.1 EXC. 1 & NFPA 14-PROVIDE STANDPIPE IN TWO STAIRWELLS W/ 2 1/2" HOSE CONNECTIONS-NATIONAL STANDARD THREADS. HOSE CONNECTIONS MAY BE PROVIDED AT FLOOR LEVEL LANDINGS IF APPROVED IN ADVANCE BY A.H.J. 4" STORZ CONNECTION REQUIRED. EACH STANDPIPE TO HAVE HOSE CONNECTION AT ROOF LEVEL.

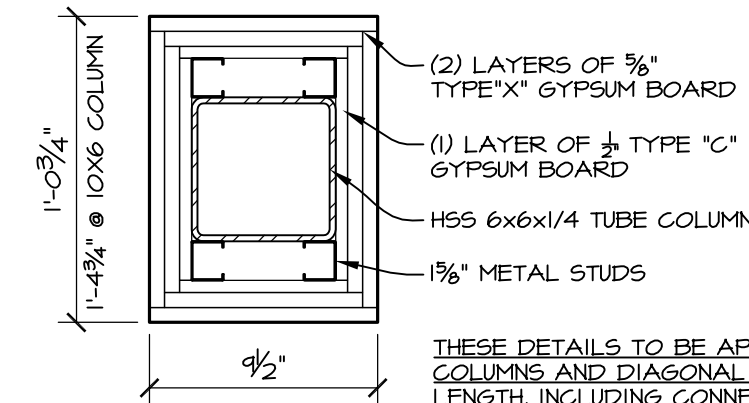

1 WRAPPED COLUMN DETAIL PC-A (3 HR.)  
 NOT TO SCALE (IBC EQUATION 1-12)

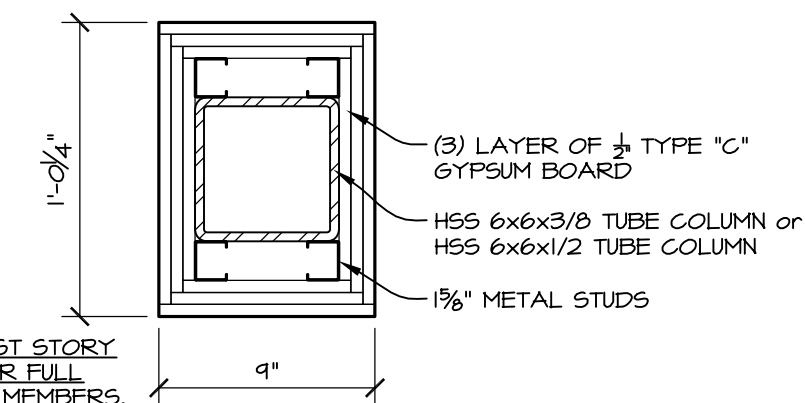

2 WRAPPED COLUMN DETAIL PC-B (3 HR.)  
 NOT TO SCALE (IBC EQUATION 1-12)

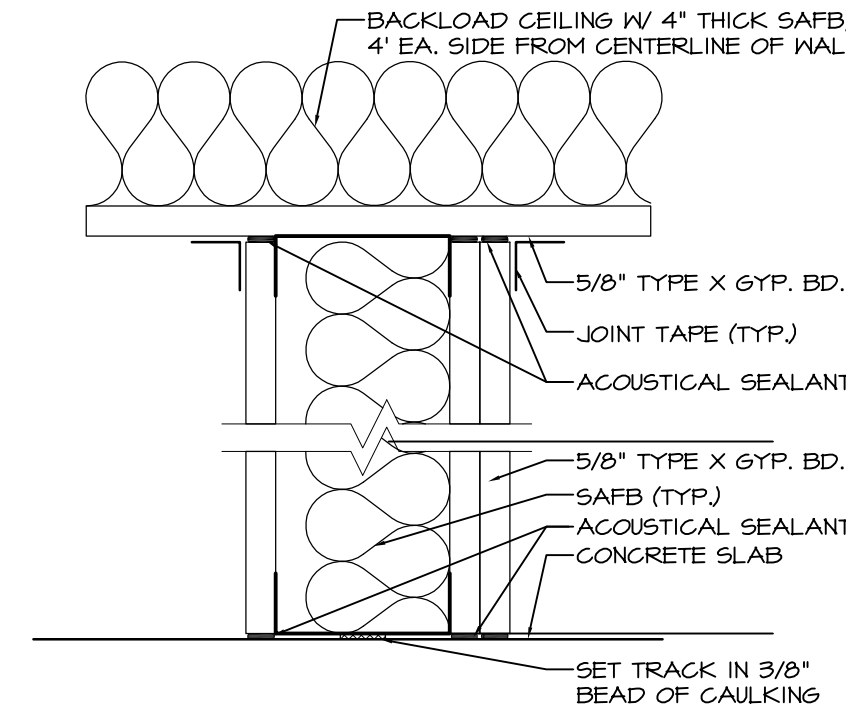

3 SOUND ISOLATION DETAIL  
 NOT TO SCALE (TYPICAL ALL GUESTROOM AND DWELLING UNIT DEMISING WALLS)

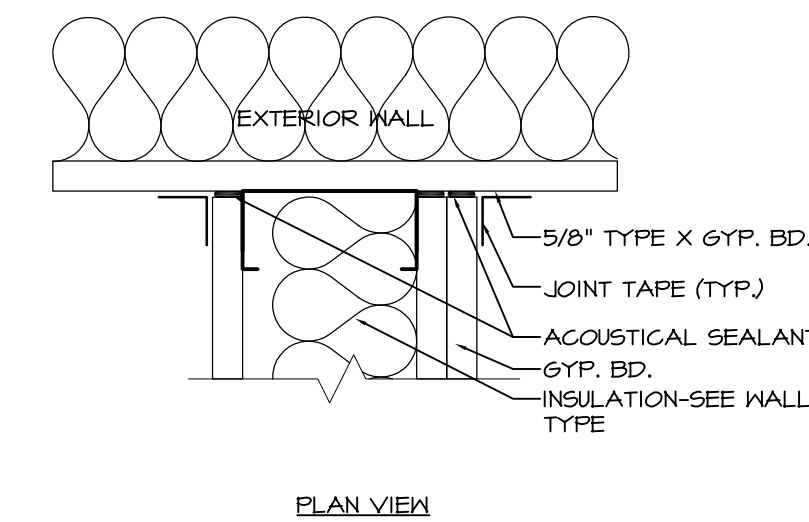

4 SOUND ISOLATION DETAIL  
 NOT TO SCALE (TYPICAL ALL GUESTROOM AND DWELLING UNIT DEMISING WALLS)

ROOM COUNT SUMMARY

ROOM TYPE	1ST FLOOR	2ND FLOOR	3RD FLOOR	4TH FLOOR	5TH FLOOR	TOTAL	%
KING	0	6	12	12	12	42	KING GUEST ROOMS - 42% OF TOTAL
KING-EXTENDED	0	0	1	1	1	3	
KING-MOD. EXT.	0	0	1	1	1	3	
KING-ACCESSIBLE	0	0	1	1	1	3	
KING SUITE	0	1	1	2	2	6	
KING SUITE-ACC.	0	0	1	0	0	1	KING GUEST ROOMS - 58% OF TOTAL
QUEEN/QUEEN	0	16	15	16	16	63	
QUEEN/QUEEN EXT.	0	0	1	1	1	3	
Q/Q ACCESSIBLE	0	0	1	1	1	3	
Q/Q SUITE	0	1	1	1	1	4	
TOTAL	0	24	35	36	36	131	
FLOOR AREAS:							
FOOTPRINT	19,501 SF						
UPPER FLOORS	18,764 SF x 5 FLOORS = 93,820 SF						
TOTAL	113,321 SF						

50% TUBS & 50% SHOWERS IN Q/Q ROOMS.

DATE	REVISION	DESCRIPTION
03-20-13 <td> <td>REVISED BUILDING INFORMATION TABLE TO INCLUDE REF. TO IBC SECTION 504, REVISED OCCUPANT LOAD CHART, REVISED PLUMBING CODE REQUIREMENTS.</td> </td>	<td>REVISED BUILDING INFORMATION TABLE TO INCLUDE REF. TO IBC SECTION 504, REVISED OCCUPANT LOAD CHART, REVISED PLUMBING CODE REQUIREMENTS.</td>	REVISED BUILDING INFORMATION TABLE TO INCLUDE REF. TO IBC SECTION 504, REVISED OCCUPANT LOAD CHART, REVISED PLUMBING CODE REQUIREMENTS.

**COPECHEE**  
 CONSTRUCTION CORPORATION  
 11 CORPORATE DRIVE, BELMONT NH 03220  
 PHONE (603) 527-9090 FAX (603) 527-9191

**CODE INFORMATION**

**PROJECT:**  
 COMMERCIAL & MAPLE STREET  
 MIXED USE DEVELOPMENT  
 PORTLAND, ME

DATE: 03-12-13  
 SCALE: SEE PLAN  
 DRAWN BY: KPH

**A0.1**  
 SHEET: