

Copyright © 2016 Opechee Construction Corporation  
Monday, May 02, 2016 5:40:12 PM

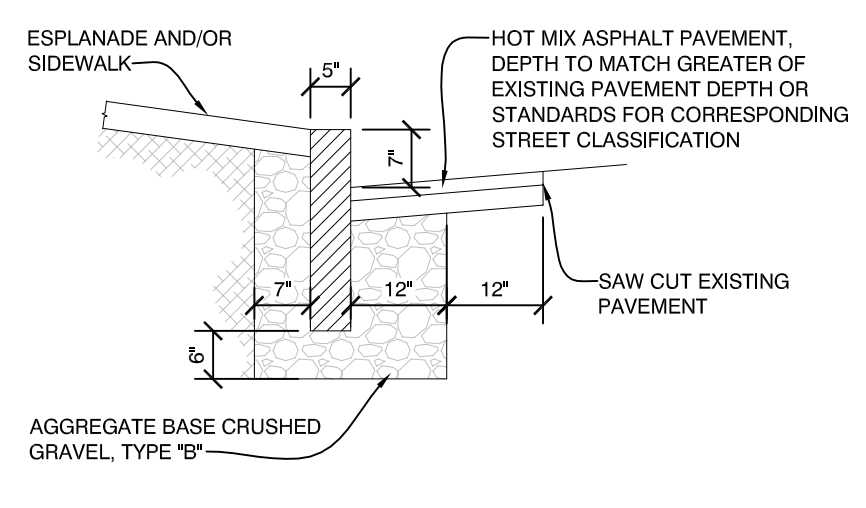

**12** CURB INSTALLATION - CROSS SECTION (TYP.)  
1/2" = 1'-0"

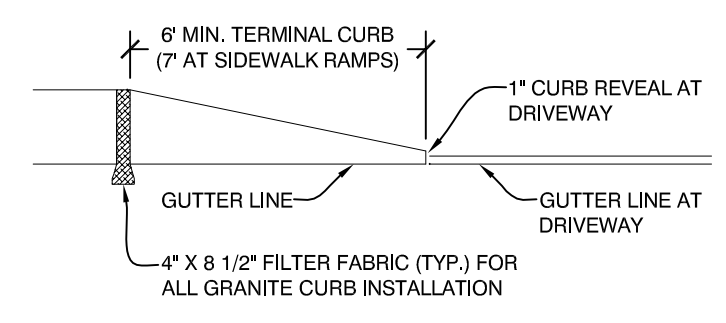

**11** CURB INSTALLATION - TERMINAL CURB PROFILE  
NOT TO SCALE

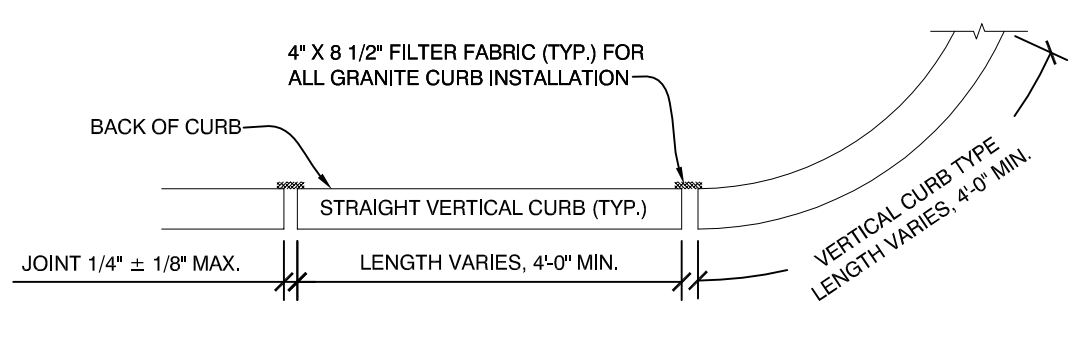

**10** CURB INSTALLATION - PLAN  
NOT TO SCALE

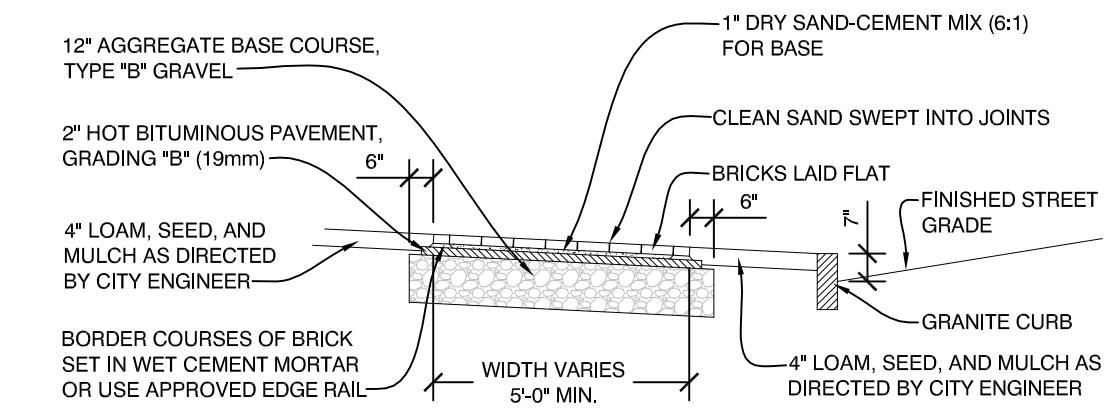

**9** BRICK & PAVER SIDEWALK SECTION  
1/4" = 1'-0"

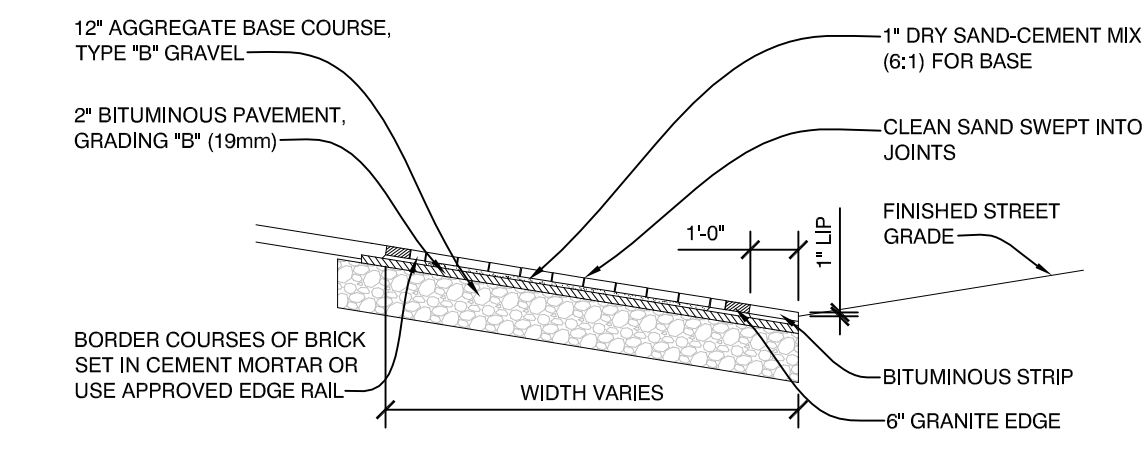

**8** BRICK DRIVEWAY APRON SECTION  
1/4" = 1'-0"

**BRICKS TO BE USED:**  
  
NEW CONSTRUCTION:  
4"x8" PINE HALL PATHWAY PAVER BRICK, MFG. BY PINE HALL BRICK CO., MADISON, NORTH CAROLINA, LACHANCE ITEM #193623, PINE HALL PATHWAY PAVER BRICK.  
  
REPAIR/ MAINTENANCE TO EXISTING:  
VERMONT PAVER, SUPPLIED BY GAGNE AND SONS, SPECIFICATION "VERMONT BACKER BRICK", ITEM #VBBB.

**NOTES:**  
  
1. COMPOSITE WET SET (REPLACEABLE) DETECTABLE WARNING PANELS SHALL BE AS MANUFACTURED BY ADA SOLUTIONS, INC. (WWW.ADATILE.COM), OR APPROVED EQUAL.  
  
2. CAST IN PLACE CONCRETE SHALL MEET SPECIFICATIONS FOR MAINE D.O.T. CLASS A STRUCTURAL MINIMUM COMPRESSIVE STRENGTH 4,000 PSI. THE CONCRETE SHALL BE SEALED PRIOR TO SETTING PANELS.  
  
3. TRUNCATED DOMES SHALL BE ALIGNED IN ROWS, PARALLEL AND PERPENDICULAR TO THE PREDOMINANT DIRECTION OF TRAVEL. NO OTHER DETECTABLE WARNING DESIGN CONFIGURATION ALLOWED.  
  
4. FOR ALL DETECTABLE WARNING PANELS, WITHIN OR ABUTTING HISTORIC DISTRICTS AND HISTORIC LANDSCAPES, "DARK GRAY" COLORED (#36118) PANELS SHALL BE USED. FOLLOW MANUFACTURER'S INSTRUCTIONS FOR INSTALLATION.  
  
5. THE DETECTABLE WARNING PANEL SHALL HAVE ONE FULL COURSE OF PINE HALL PATHWAY PAVERS (THE CURRENT BRICK STANDARD) AROUND THE FULL PERIMETER OF THE PANEL. THIS PERIMETER COURSE SHALL BE SET USING PORTLAND MORTAR CEMENT TO CREATE A FLUSH SURFACE BETWEEN THE BRICK AND THE PANEL.  
  
6.) SIZE: THE DETECTABLE WARNING PANEL(S) SHALL EXTEND 24" MINIMUM IN THE DIRECTION OF TRAVEL AND THE FULL WIDTH OF THE CURB RAMP, LANDING, OR BLENDED TRANSITION TO THE STREET.  
  
7. ORIENTATION: THE DETECTABLE WARNING PANEL SHALL BE LOCATED SO THAT THE EDGE NEAREST THE CURB LINE IS 6" MINIMUM AND 8" MAXIMUM FROM THE CURB LINE. THE PANEL SHALL BE ORIENTED TO THE DIRECTION OF TRAVEL AS IDENTIFIED BY THE POINT OF EGRESS.

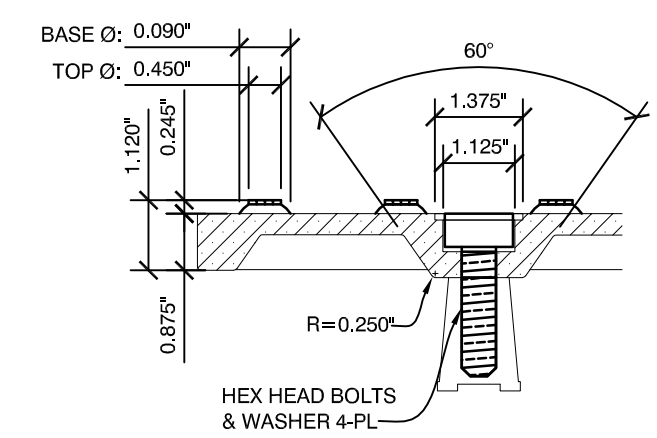

**7** DETECTABLE WARNING STRIP - BOLT DETAIL  
NOT TO SCALE

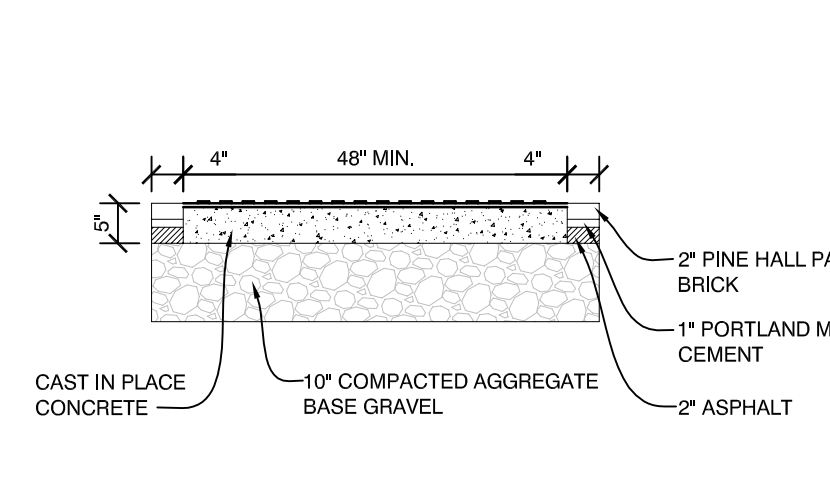

**6** DETECTABLE WARNING STRIP - SECTION  
1/2" = 1'-0"

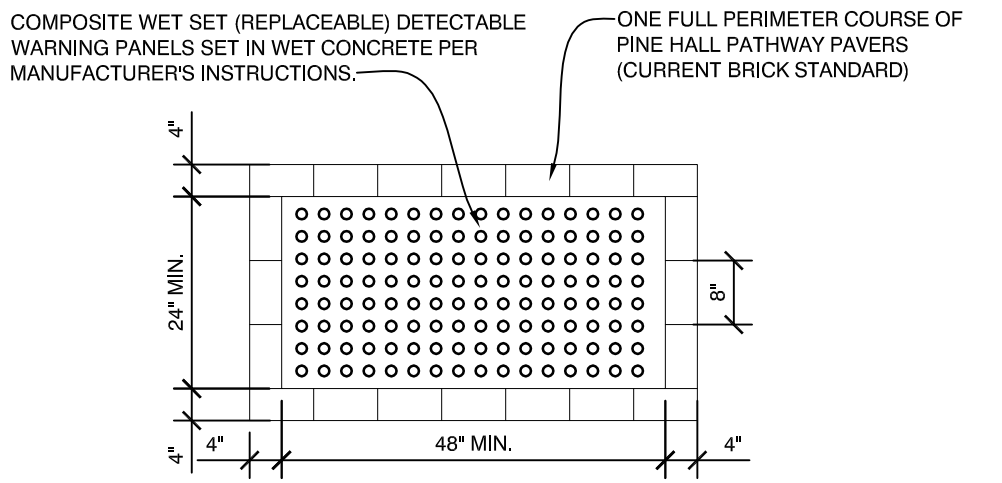

**5** DETECTABLE WARNING STRIP - PLAN  
1/2" = 1'-0"

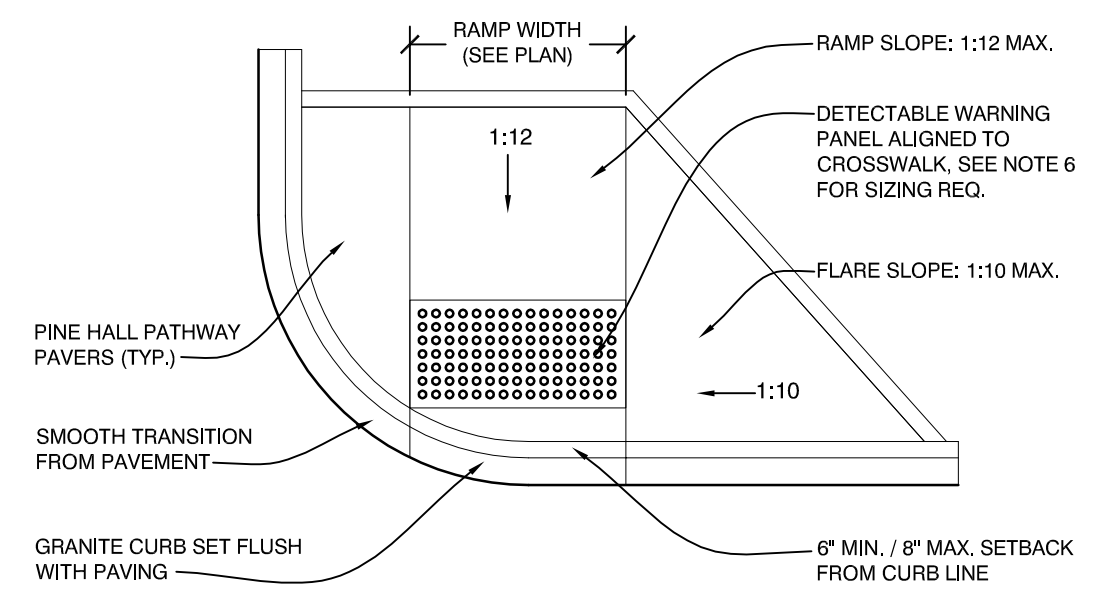

**4** DETECTABLE WARNING STRIP - RAMP DETAIL  
3/4" = 1'-0"

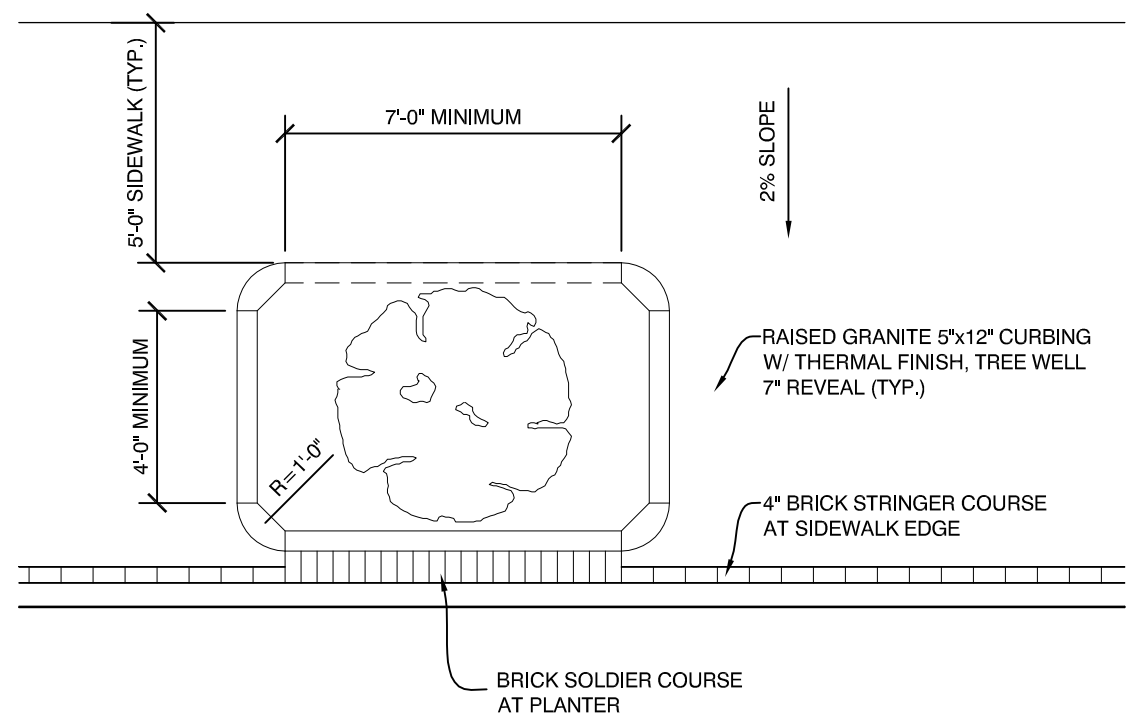

**3** TREE WELL DETAIL  
1/4" = 1'-0"

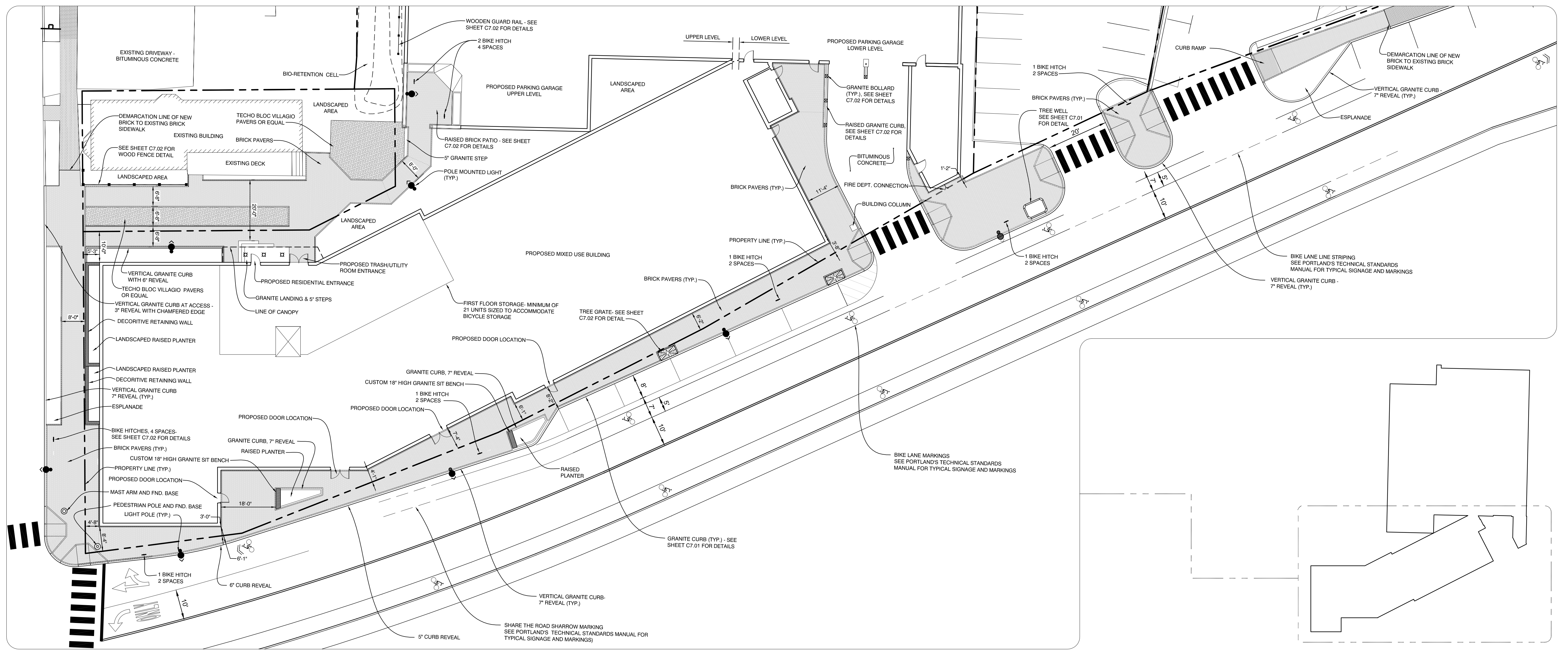

**2** HARDSCAPE PLAN - MIXED USE  
1/16" = 1'-0"

**1** HARDSCAPE KEY PLAN  
1/64" = 1'-0"