

DISPLAY THIS CARD ON PRINCIPAL FRONTAGE OF WORK CITY OF PORTLAND

Please Read Application And Notes, If Any, Attached

BUILDING INSPECTION

PERMIT

Permit Number: 070489

PERMIT ISSUED

MAY 25 2007

CITY OF PORTLAND

This is to certify that TREEHOUSE LLC /CSI Builders

has permission to Replace and install 7 windows

AT 45 DANFORTH ST

040 B032001

provided that the person or persons who perform or supervise the work accepting this permit shall comply with all of the provisions of the Statutes of the State of Oregon and of the Ordinances of the City of Portland regulating the construction, maintenance and use of buildings and structures, and of the application on file in this department.

Apply to Public Works for street line and grade if nature of work requires such information.

Notification of inspection must be given and when permission is procured before this building or part thereof is altered or closed-in. 24 HOUR NOTICE IS REQUIRED.

A certificate of occupancy must be procured by owner before this building or part thereof is occupied.

OTHER REQUIRED APPROVALS

Fire Dept. _____

Health Dept. _____

Appeal Board _____

Other _____
Department Name

5/25/07 Chris J. Park
Director - Building & Inspection Services

PENALTY FOR REMOVING THIS CARD

City of Portland, Maine - Building or Use Permit Application

389 Congress Street, 04101 Tel: (207) 874-8703, Fax: (207) 874-8716

Permit No: 07-0489	Issue Date:	CBL: 040 B032001
-----------------------	-------------	---------------------

Location of Construction: 45 DANFORTH ST	Owner Name: TREEHOUSE LLC	Owner Address: 70 CENTER ST 3RD FLOOR	Phone:
Business Name:	Contractor Name: CSI Builders	Contractor Address: 41B Woodville Falmouth	Phone 2078316966
Lessee/Buyer's Name	Phone:	Permit Type: Alterations - Commercial	Zone: B-3

Past Use: Commercial Restaurant/ Bar	Proposed Use: Commercial Restaurant/ Bar - Replace and install 7 windows	Permit Fee: \$90.00	Cost of Work: \$7,000.00	CEO District: 1
		FIRE DEPT: <input type="checkbox"/> Approved <input type="checkbox"/> Denied N/A	INSPECTION: Use Group: B Type: 5B IBC 2003	

Proposed Project Description: Replace and install 7 windows	Signature: Greg Cass	Signature: 5/25/07 Chr M
PEDESTRIAN ACTIVITIES DISTRICT (P.A.D.)		
Action: <input type="checkbox"/> Approved <input type="checkbox"/> Approved w/Conditions <input type="checkbox"/> Denied		
Signature:		Date:

Permit Taken By: Idobson	Date Applied For: 05/07/2007	Zoning Approval	
-----------------------------	---------------------------------	------------------------	--

1. This permit application does not preclude the Applicant(s) from meeting applicable State and Federal Rules. 2. Building permits do not include plumbing, septic or electrical work. 3. Building permits are void if work is not started within six (6) months of the date of issuance. False information may invalidate a building permit and stop all work.	Special Zone or Reviews <input type="checkbox"/> Shoreland <input type="checkbox"/> Wetland <input type="checkbox"/> Flood Zone <input type="checkbox"/> Subdivision <input type="checkbox"/> Site Plan	Zoning Appeal <input type="checkbox"/> Variance <input type="checkbox"/> Miscellaneous <input type="checkbox"/> Conditional Use <input type="checkbox"/> Interpretation <input type="checkbox"/> Approved <input type="checkbox"/> Denied	Historic Preservation <input checked="" type="checkbox"/> Not in District or Landmark <input type="checkbox"/> Does Not Require Review <input type="checkbox"/> Requires Review <input type="checkbox"/> Approved <input type="checkbox"/> Approved w/Conditions <input type="checkbox"/> Denied
	Maj <input type="checkbox"/> Minor <input type="checkbox"/> MM <input type="checkbox"/> Date: 5/22/07	Date:	Date:

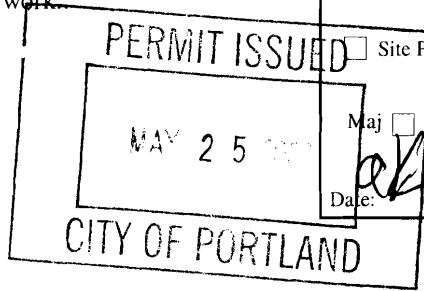

CERTIFICATION

I hereby certify that I am the owner of record of the named property, or that the proposed work is authorized by the owner of record and that I have been authorized by the owner to make this application as his authorized agent and I agree to conform to all applicable laws of this jurisdiction. In addition, if a permit for work described in the application is issued, I certify that the code official's authorized representative shall have the authority to enter all areas covered by such permit at any reasonable hour to enforce the provision of the code(s) applicable to such permit.

SIGNATURE OF APPLICANT	ADDRESS	DATE	PHONE
RESPONSIBLE PERSON IN CHARGE OF WORK, TITLE		DATE	PHONE

City of Portland, Maine - Building or Use Permit

389 Congress Street, 04101 Tel: (207) 874-8703, Fax: (207) 874-8716

Permit No: 07-0489	Date Applied For: 05/04/2007	CBL: 040 B032001
------------------------------	--	----------------------------

Location of Construction: 45 DANFORTH ST	Owner Name: TREEHOUSE LLC	Owner Address: 70 CENTER ST 3RD FLOOR	Phone:
Business Name:	Contractor Name: CSI Builders	Contractor Address: 41B Woodville Falmouth	Phone (207) 831-6966
Lessee/Buyer's Name	Phone:	Permit Type: Alterations - Commercial	

Proposed Use: Commercial Restaurant/ Bar - Replace and install 7 windows	Proposed Project Description: Replace and install 7 windows
--	---

Dept: Zoning **Status:** Approved **Reviewer:** Marge Schmuckal **Approval Date:** 05/22/2007
Note: **Ok to Issue:**

Dept: Building **Status:** Approved with Conditions **Reviewer:** Chris Hanson **Approval Date:** 05/25/2007
Note: **Ok to Issue:**

- 1) Fastener schedule per the IRC 2003
- 2) Application approval based upon information provided by applicant. Any deviation from approved plans requires separate review and approval prior to work.

Dept: Fire **Status:** Approved **Reviewer:** Capt Greg Cass **Approval Date:**
Note: **Ok to Issue:**

May 3, 2007

To: Portland Inspections
From: Joe Cooper, Treehouse, LLC

RE: Building Permit-replacement of Windows

Dear Sir or Madam:

Please find attached our application for a building permit to replace seven windows at 45 Danforth Street.

Per the checklist please review the following:

1-Cross Section w/framing details-All windows are replacement windows –any new framing will consist of two 2x10x length of window (window specs attached) with ½ “ Plywood Spacer for width of window

2) Window schedules-Attached herewith

All other items are not applicable

If you have any questions please contact the contractor as identified on the attached permit application.

Window Schedule



Remove Window

Remove Window

A

B

B

Rev	Description	Initials	Date
-----	-------------	----------	------

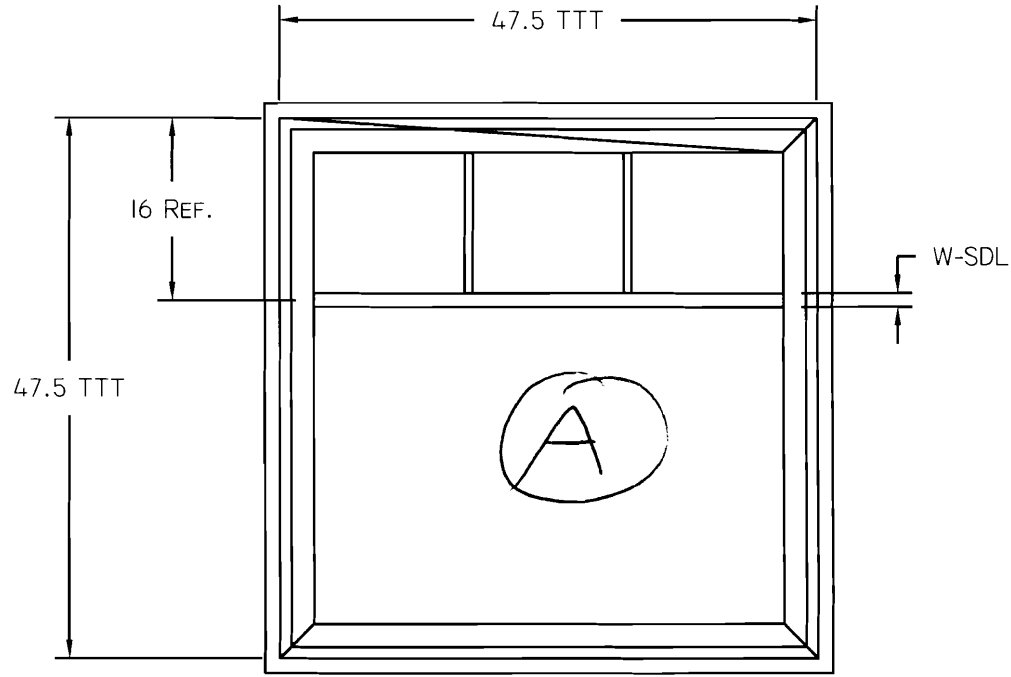

NOTES:

1. W-SDL = 1.25" WIDE SDL APPLIED INSIDE & OUT.
2. SDL'S ARE APPLIED TO THE EXTERIOR ONLY, ALIGNED/CENTERED OVER THE GBG'S.
3. GRIDS ARE DIMENSIONED FROM EDGE OF FRAME TO CENTERLINE OF GRID.
4. DIMENSIONS ARE ROUNDED TO THE NEAREST 1/16" FOR PRODUCTION PURPOSES.

		Customer Name:	Hancock Lumber		Job Name or No:	Cooper		
Line/Item No:	1		Product Description:				NC Fixed Casement	
Window:	Qty:	Glass Type (Top/Btm):		Grid Pattern (Top/Btm):	Screen:			
-	1	Low E		Suspended 3V, Cont.	N/A			
Dimensions:		Tolerances:		Drawing Size:	Drawing No:			
ALL DIMENSIONS ARE IN INCHES UNLESS SPECIFIED OTHERWISE.		All tolerances are subject to current industry standards.		A	Hancock Lumber - Cooper			
NOTICE: This document contains information that is proprietary to and is protected by copyright of Paradigm Window Solutions For Life. This information may not be copied, disclosed to others or used for any purpose other than that for which it is given without written permission from Paradigm. Copyright © 2007 Paradigm Window Solutions For Life. All Rights Reserved.				Scale:	Drawn By:	Drawing Date:		
				1:16	BCG	03/30/07		
				Page:	Checked By:	Revision Level:		
				1 of 3	-	A		

Rev	Description	Initials	Date
-----	-------------	----------	------

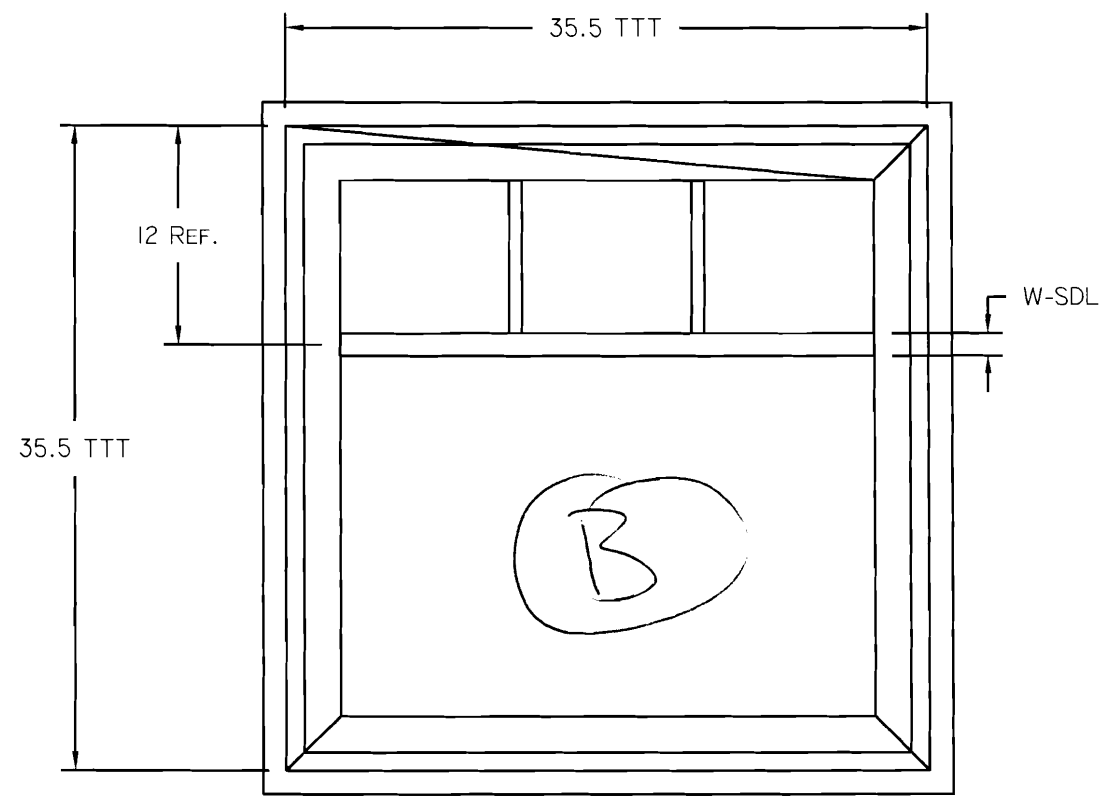

NOTES:

1. W-SDL = 1.25" WIDE SDL APPLIED INSIDE & OUT.
2. SDL'S ARE APPLIED TO THE EXTERIOR ONLY, ALIGNED/CENTERED OVER THE GBG'S.
3. GRIDS ARE DIMENSIONED FROM EDGE OF FRAME TO CENTERLINE OF GRID.
4. DIMENSIONS ARE ROUNDED TO THE NEAREST 1/16" FOR PRODUCTION PURPOSES.

		Customer Name:	Job Name or No:	
		Hancock Lumber	Cooper	
Line/Item No:	Product Description:			
2	NC Fixed Casement			
Window:	Qty:	Glass Type (Top/Btm):	Grid Pattern (Top/Btm):	Screen:
-	1	Low E	Suspended 3V, Cont.	N/A
Dimensions:	Tolerances:		Drawing Size:	Drawing No:
ALL DIMENSIONS ARE IN INCHES UNLESS SPECIFIED OTHERWISE.	All tolerances are subject to current industry standards.		A	Hancock Lumber - Cooper
NOTICE: This document contains information that is proprietary to and is protected by copyright of Paradigm Window Solutions For Life. This information may not be copied, disclosed to others or used for any purpose other than that for which it is given without written permission from Paradigm. Copyright © 2007 Paradigm Window Solutions For Life. All Rights Reserved.		Scale:	Drawn By:	Drawing Date:
		1:10	BCG	03/30/07
		Page:	Checked By:	Revision Level:
		2 of 3	-	A

Rev	Description	Initials	Date
-----	-------------	----------	------

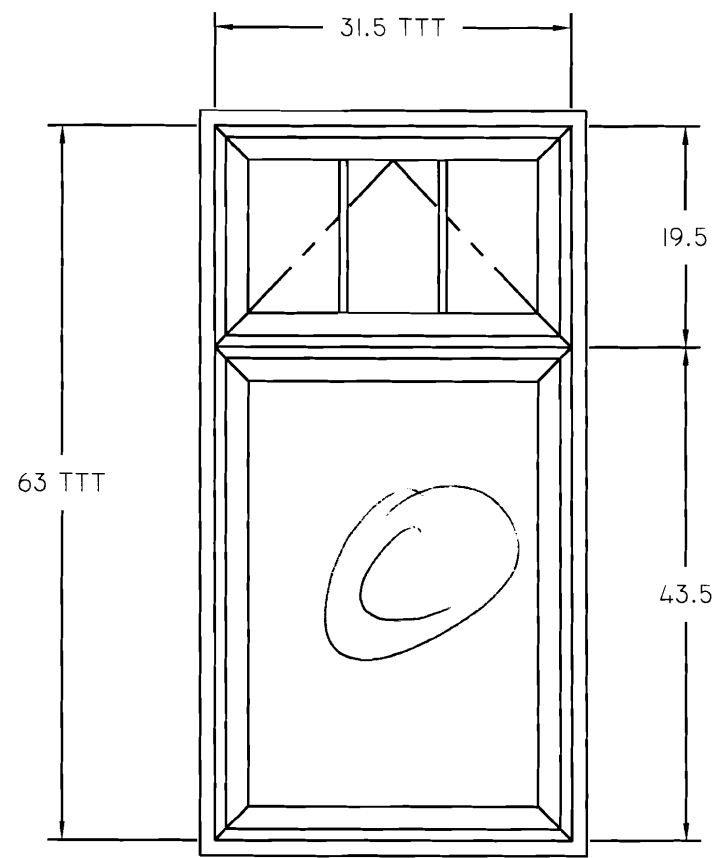

NOTES:
 1. SDL'S ARE APPLIED TO THE EXTERIOR ONLY, ALIGNED/CENTERED OVER THE GBG'S.

paradigm Window Solutions For Life.		Customer Name: Hancock Lumber	Job Name or No: Cooper
Line/Item No: 3	Product Description: NC 2-High, Awning over Fixed Casement		
Window: -	Qty: 1	Glass Type (Top/Btm): Low E	Grid Pattern (Top/Btm): 3V over None, Cont.
Screen: Full			
Dimensions: ALL DIMENSIONS ARE IN INCHES UNLESS SPECIFIED OTHERWISE.	Tolerances: All tolerances are subject to current industry standards.	Drawing Size: A	Drawing No: Hancock Lumber - Cooper
NOTICE: This document contains information that is proprietary to and is protected by copyright of Paradigm Window Solutions For Life. This information may not be copied, disclosed to others or used for any purpose other than that for which it is given without written permission from Paradigm. Copyright © 2007 Paradigm Window Solutions For Life. All Rights Reserved.		Scale: 1:16	Drawn By: BCG
		Page: 3 of 3	Drawing Date: 03/30/07
		Checked By: -	Revision Level: A