

DISPLAY THIS CARD ON PRINCIPAL FRONTAGE OF WORK CITY OF PORTLAND

BUILDING DEPARTMENT

PERMIT

Permit Number: 021291

Please Read Application And Notes, If Any, Attached

This is to certify that Giobbi Archie S &/Restaurant equipment of Maine
has permission to Install new ventalating / exhaust hood with fire system.
AT 1 Danforth St L 040 B028001

provided that the person or persons, firm or corporation accepting this permit shall comply with all of the provisions of the Statutes of Maine and of the ordinances of the City of Portland regulating the construction, maintenance and use of buildings and structures, and of the application on file in this department.

Apply to Public Works for street line and grade if nature of work requires such information.

Notification of inspection must be given and when permission is procured before this building or part thereof is occupied or closed-in. HEAR NOTICE IS REQUIRED.

A certificate of occupancy must be procured by owner before this building or part thereof is occupied.

OTHER REQUIRED APPROVALS

Fire Dept. [Signature]
Health Dept. _____
Appeal Board _____
Other _____
Department Name

[Signature] 11/20/02
Director - Building & Inspection Services

PENALTY FOR REMOVING THIS CARD

City of Portland, Maine - Building or Use Permit Application

389 Congress Street, 04101 Tel: (207) 874-8703, Fax: (207) 874-8716

Permit No: 02-1291	Issue Date:	CBL: 040 B028001
-----------------------	-------------	---------------------

Location of Construction: 1 Danforth St	Owner Name: Giobbi Archie S &	Owner Address: 1 Danforth St	Phone: 207-232-5343
Business Name: n/a	Contractor Name: Restaurant Equipement of Maine	Contractor Address: 75 York Street Portland	Phone 2077737376
Lessee/Buyer's Name n/a	Phone: n/a	Permit Type: Alterations - Commercial	Zone: B-3

Past Use: Commercial / Yosaku Restaurant	Proposed Use: Restaurant / Install new ventalating / exhaust hood with fire system	Permit Fee: \$93.00	Cost of Work: \$9,800.00	CEO District: 2
Proposed Project Description: Install new ventalating / exhaust hood with fire system.		FIRE DEPT: <input checked="" type="checkbox"/> Approved <input type="checkbox"/> Denied	INSPECTION: Use Group: A3 Type: NA 11/21/02 <i>[Signature]</i>	
		Signature: <i>[Signature]</i>	Signature: <i>[Signature]</i>	
PEDESTRIAN ACTIVITIES DISTRICT (P.A.D.)				
Action: <input type="checkbox"/> Approved <input type="checkbox"/> Approved w/Conditions <input type="checkbox"/> Denied				
Signature: _____ Date: _____				

Permit Taken By: gg	Date Applied For: 11/15/2002	Zoning Approval
------------------------	---------------------------------	------------------------

- This permit application does not preclude the Applicant(s) from meeting applicable State and Federal Rules.
- Building permits do not include plumbing, septic or electrical work.
- Building permits are void if work is not started within six (6) months of the date of issuance. False information may invalidate a building permit and stop all work..

Special Zone or Reviews <input type="checkbox"/> Shoreland <input type="checkbox"/> Wetland <input type="checkbox"/> Flood Zone <input type="checkbox"/> Subdivision <input type="checkbox"/> Site Plan Major <input type="checkbox"/> Minor <input type="checkbox"/> MM <input type="checkbox"/> Date: 11/19/02	Zoning Appeal <input type="checkbox"/> Variance <input type="checkbox"/> Miscellaneous <input type="checkbox"/> Conditional Use <input type="checkbox"/> Interpretation <input type="checkbox"/> Approved <input type="checkbox"/> Denied Date:	Historic Preservation <input checked="" type="checkbox"/> Not in District or Landmark <input type="checkbox"/> Does Not Require Review <input type="checkbox"/> Requires Review <input type="checkbox"/> Approved <input type="checkbox"/> Approved w/Conditions <input type="checkbox"/> Denied Date:
--	---	--

Separate permits required for any new sign app

CERTIFICATION

I hereby certify that I am the owner of record of the named property, or that the proposed work is authorized by the owner of record and that I have been authorized by the owner to make this application as his authorized agent and I agree to conform to all applicable laws of this jurisdiction. In addition, if a permit for work described in the application is issued, I certify that the code official's authorized representative shall have the authority to enter all areas covered by such permit at any reasonable hour to enforce the provision of the code(s) applicable to such permit.

SIGNATURE OF APPLICANT ADDRESS DATE PHONE

RESPONSIBLE PERSON IN CHARGE OF WORK, TITLE DATE PHONE

All Purpose Building Permit Application

If you or the property owner owes real estate or personal property taxes or user charges on any property within the City, payment arrangements must be made before permits of any kind are accepted.

Location/Address of Construction: <u>ONE DANFORTH STREET PORTLAND, ME 04101</u>		
Total Square Footage of Proposed Structure <u>2625 sq. ft. existing structure</u>	Square Footage of Lot <u>6378</u>	
Tax Assessor's Chart, Block & Lot Chart# <u>40</u> Block# <u>B</u> Lot# <u>2B</u> <u>040-B-028-001</u>	Owner: <u>ARENHE GIOBBI</u> <u>MATILDA GIOBBI</u>	Telephone: <u>232-5343</u>
Lessee/Buyer's Name (If Applicable) <u>SATO SEARUE ENTERPRISES</u>	Applicant name, address & telephone:	Cost Of Work: <u>\$9800.00</u> Fee: \$ <u>93.00</u>
Current use: <u>YOSAKU RESTAURANT</u>		
If the location is currently vacant, what was prior use: <u>-</u>		
Approximately how long has it been vacant: <u>-</u>		
Proposed use: <u>YOSAKU RESTAURANT</u>		
Project description: <u>INSTALL NEW VENTILATING / EXHAUST (HOOD W) FIRE SYSTEM</u> <u>Kitchen</u>		
Contractor's name, address & telephone:		
Who should we contact when the permit is ready: <u>ERIC TAYLOR</u> <i>TX</i>		
Mailing address: <u>RESTAURANT EQUIPMENT OF MAINE</u> <u>75 YORK STREET</u> <u>PORTLAND, ME 04101</u>		
We will contact you by phone when the permit is ready. You must come in and pick up the permit and review the requirements before starting any work, with a Plan Reviewer. A stop work order will be issued and a \$100.00 fee if any work starts before the permit is picked up. PHONE: <u>773-7376</u> <i>TX</i>		

IF THE REQUIRED INFORMATION IS NOT INCLUDED IN THE SUBMISSIONS THE PERMIT WILL BE AUTOMATICALLY DENIED AT THE DISCRETION OF THE BUILDING/PLANNING DEPARTMENT, WE MAY REQUIRE ADDITIONAL INFORMATION IN ORDER TO APPROVE THIS PERMIT. *Call*

I hereby certify that I am the Owner of record of the named property, or that the owner of record authorizes the proposed work and that I have been authorized by the owner to make this application as his/her authorized agent. I agree to conform to all applicable laws of this jurisdiction. In addition, if a permit for work described in this application is issued, I certify that the Code Official's authorized representative shall have the authority to enter all areas covered by this permit at any reasonable hour to enforce the provisions of the codes applicable to this permit.

Signature of applicant:	Date:
-------------------------	-------

This is NOT a permit, you may not commence ANY work until the permit is issued. If you are in a Historic District you may be subject to additional permitting City of fees with the Planning Department on the 4th floor of City Hall.

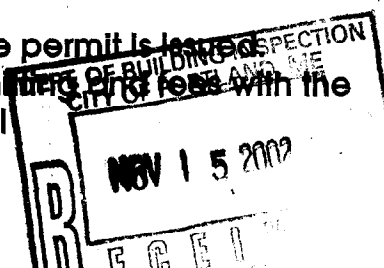

AMERICAN HOOD SYSTEMS INC.

177 REASER COURT / P.O. BOX 1377
 ELYRIA, OHIO
 44036-1377

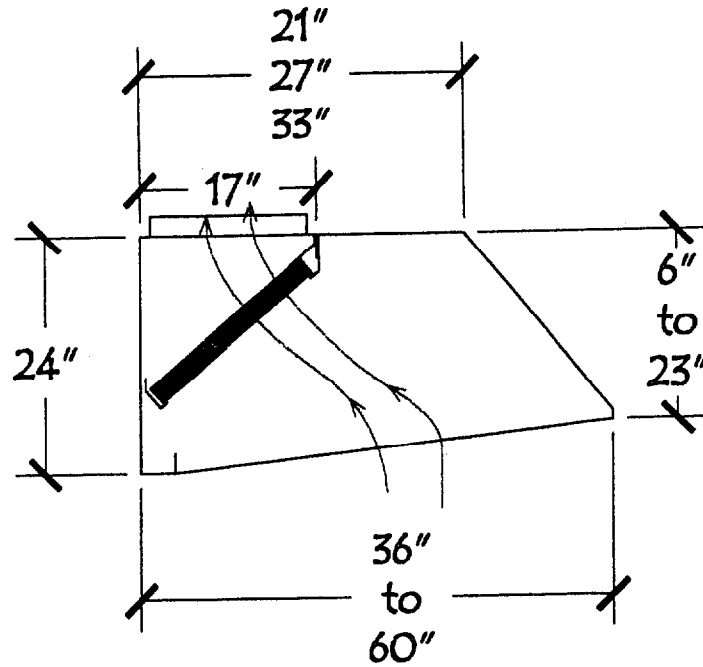

SECTION VIEW

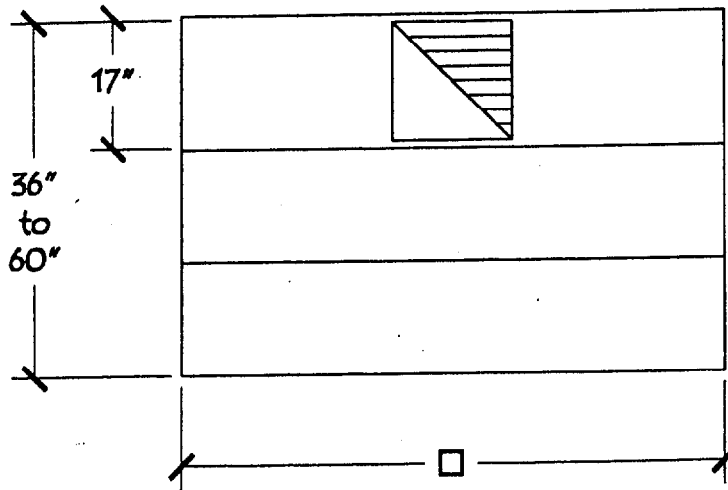

STANDARD FEATURES:

1. 16 GAUGE ALUMINIZED OR STAINLESS STEEL
2. ALL JOINTS SEAMLESSLY TIG/MIG WELDED
3. ALUMINIZED POLISHED PAINTED SEMI-GLOSS STAINLESS - #4 POLISHED FINISH
4. GALVANIZED BAFFLE FILTERS ARE UL LISTED
5. VAPOR PROOF LIGHTS ARE UL LISTED (OPTIONAL)
6. STAINLESS STEEL GREASE CATCH PAN
7. MEETS AND EXCEEDS NFPA #96

ETL LISTED
**EXHAUST HOODS
 FOR COMMERCIAL
 COOKING EQUIPMENT**
 3006318
CONFORMS TO UL STD 710



LOW CEILING TAPERED EXHAUST HOOD			
TOL	DATE	SCALE	MATL
PARTS #			

Side View

3 INCH
FIRE STANDOFF

4'

Light's

Suspended
w/ chains from Roof
Girders.

20"

5/8 Fire Rock

w/ Layer of
on walls

Grease Laden
VAPORS THRU Battles

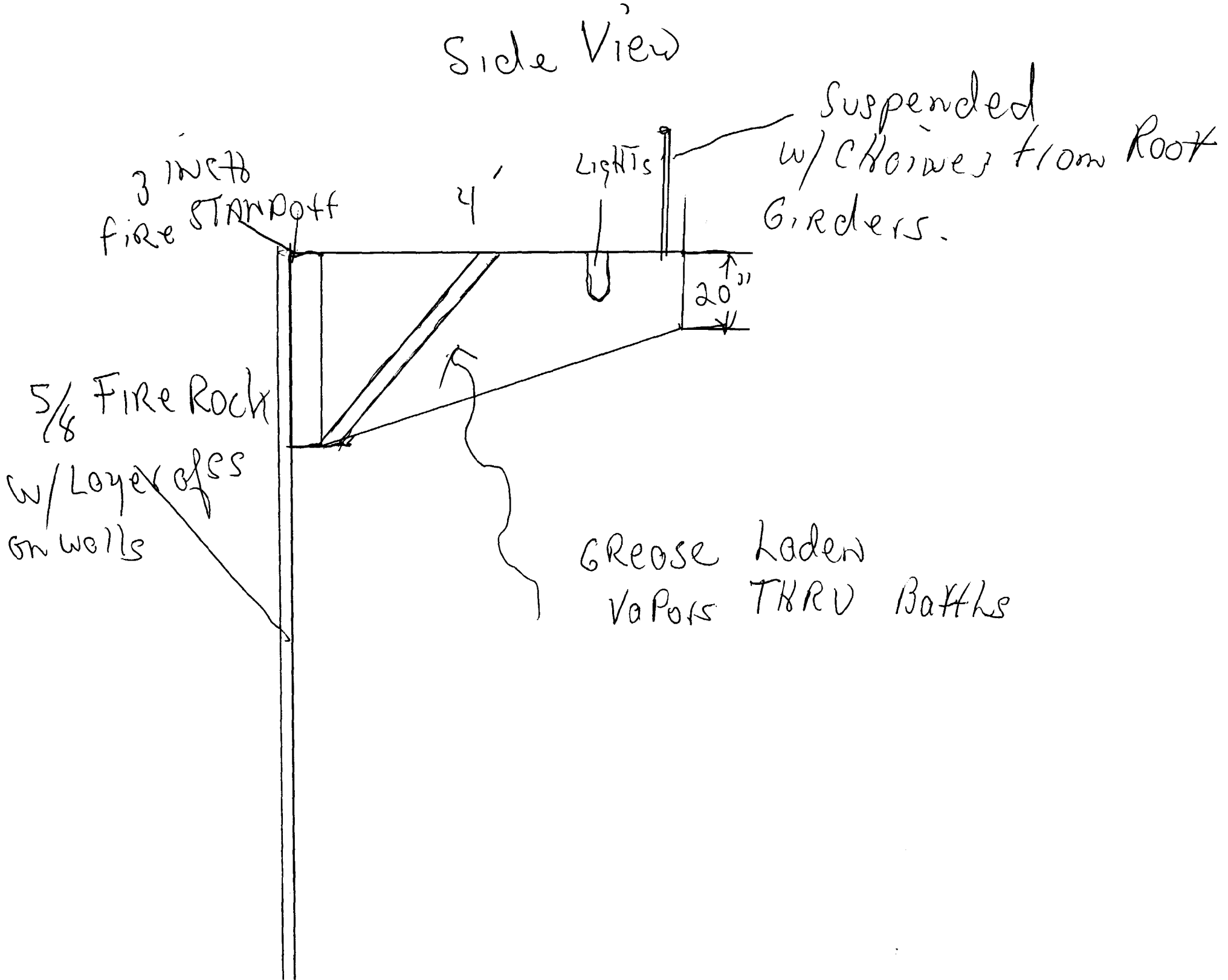

Kitchew View of New Rest.
One DANFORTH Street
PITLD, me, 04101

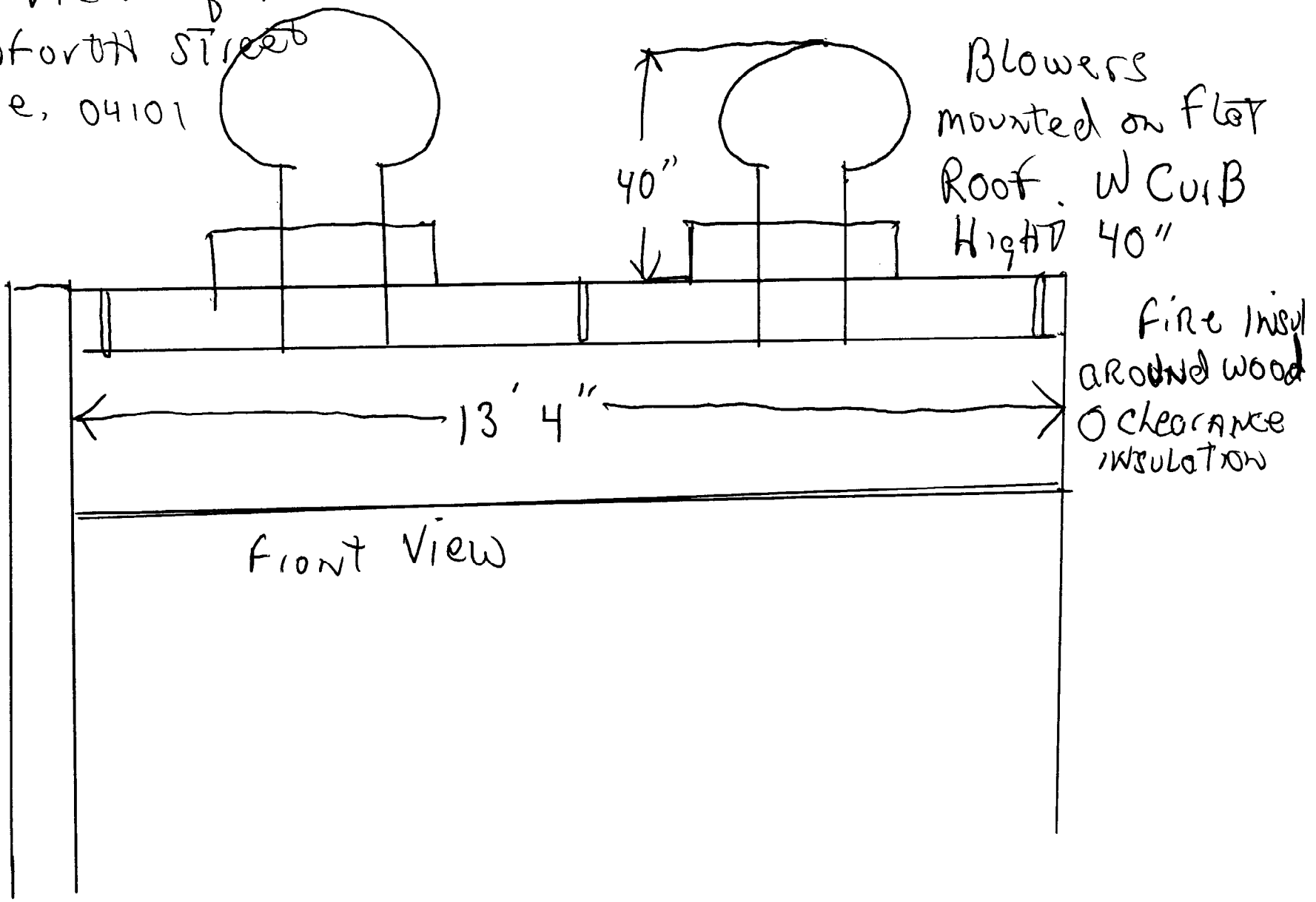



CITY OF PORTLAND, MAINE
Department of Building Inspections

Dec 15 2007

Received from _____

Location of Work _____

Cost of Construction \$ _____

Permit Fee \$ _____

Building (IL) Plumbing (I5) _____ Electrical (I2) _____ Site Plan (U2) _____

Other _____

CBL: _____

Check #: _____ Total Collected \$ _____

THIS IS NOT A PERMIT

No work is to be started until PERMIT CARD is actually posted upon the premises. Acceptance of fee is no guarantee that permit will be granted. PRESERVE THIS RECEIPT. In case permit cannot be granted the amount of the fee will be refunded upon return of the receipt less \$10.00 or 10% whichever is greater.

WHITE - Applicant's Copy
YELLOW - Office Copy
PINK - Permit Copy