

19 FRENCH BALCONY AT STONE VENEER  
SCALE: 3/4"=1'-0"

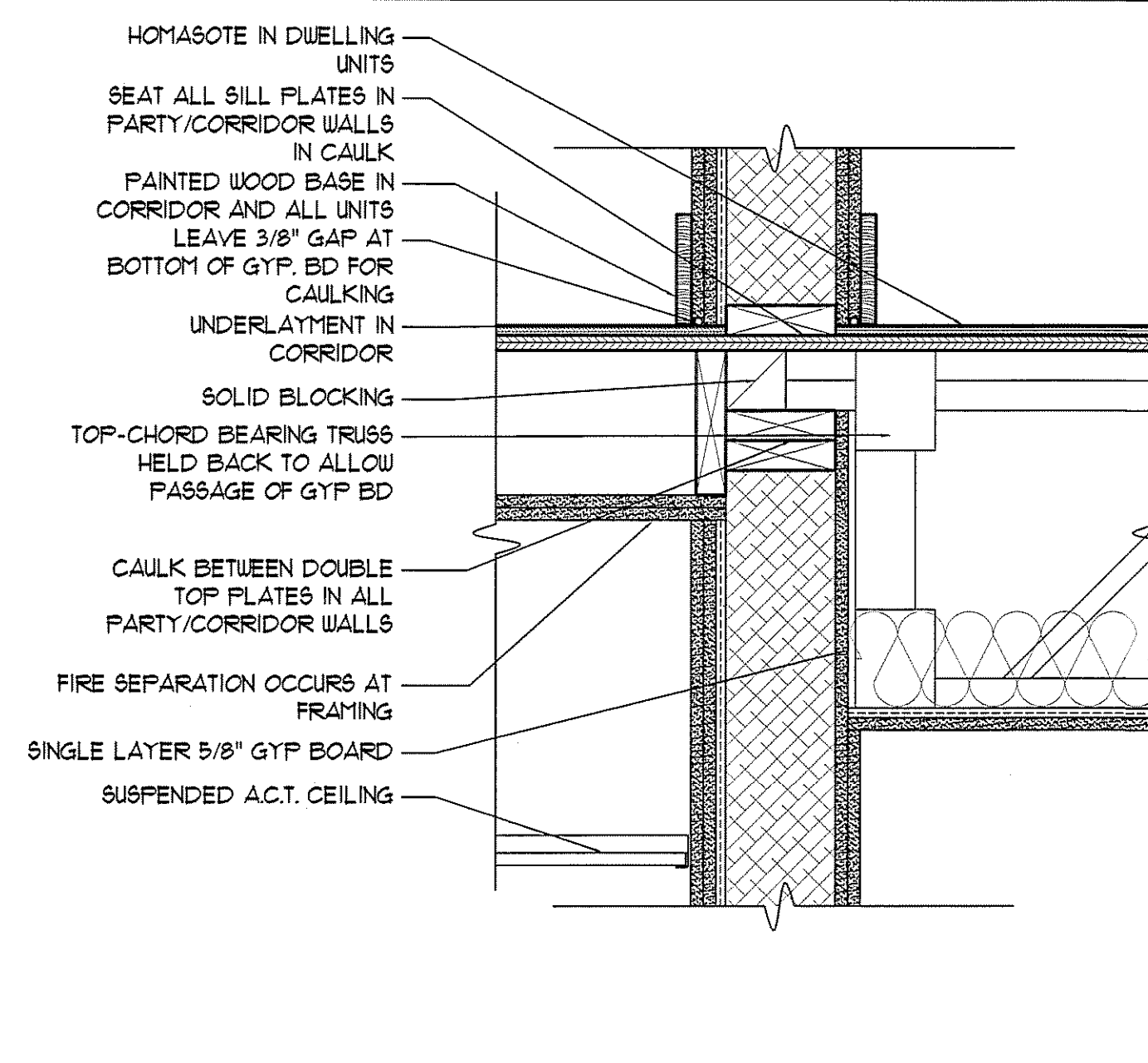

16 DETAIL AT CORRIDOR WALL/FLOOR INTERSECTION  
SCALE: 1 1/2"=1'-0"

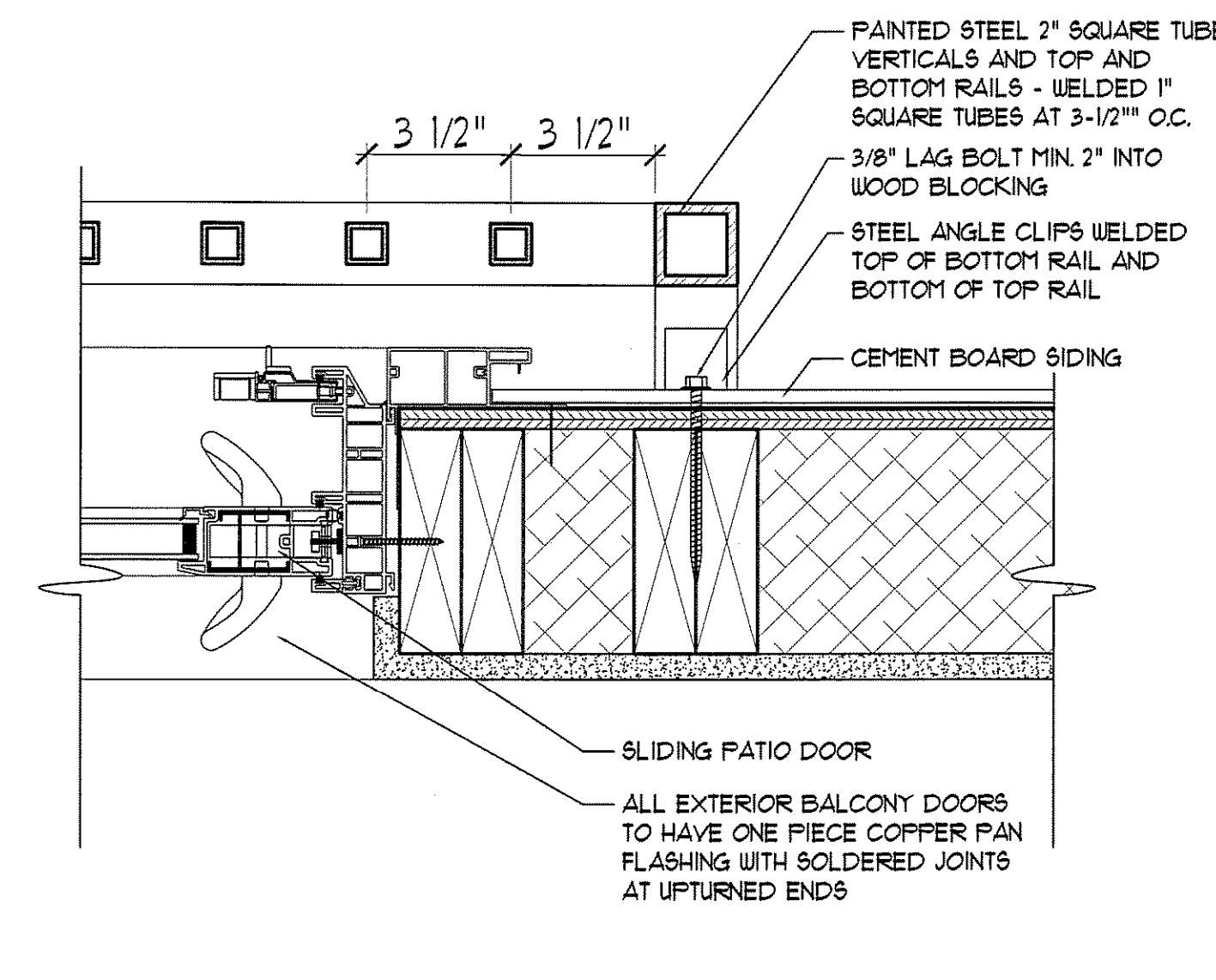

13 FRENCH BALCONY AT VINYL PATIO DOOR  
SCALE: 3/4"=1'-0"

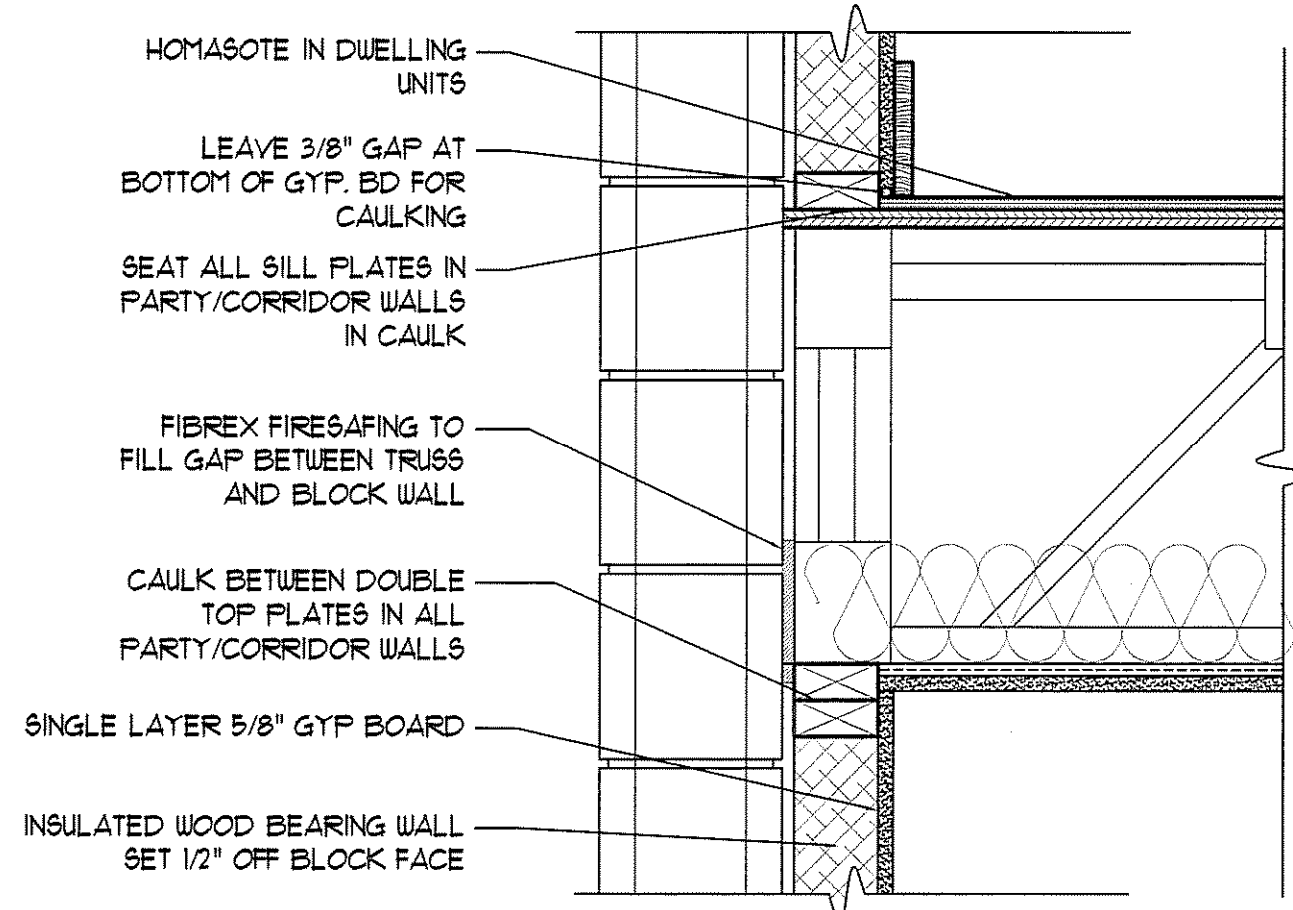

20 WOOD FRAMING FIRESTOPPING DETAIL  
SCALE: 1 1/2"=1'-0"

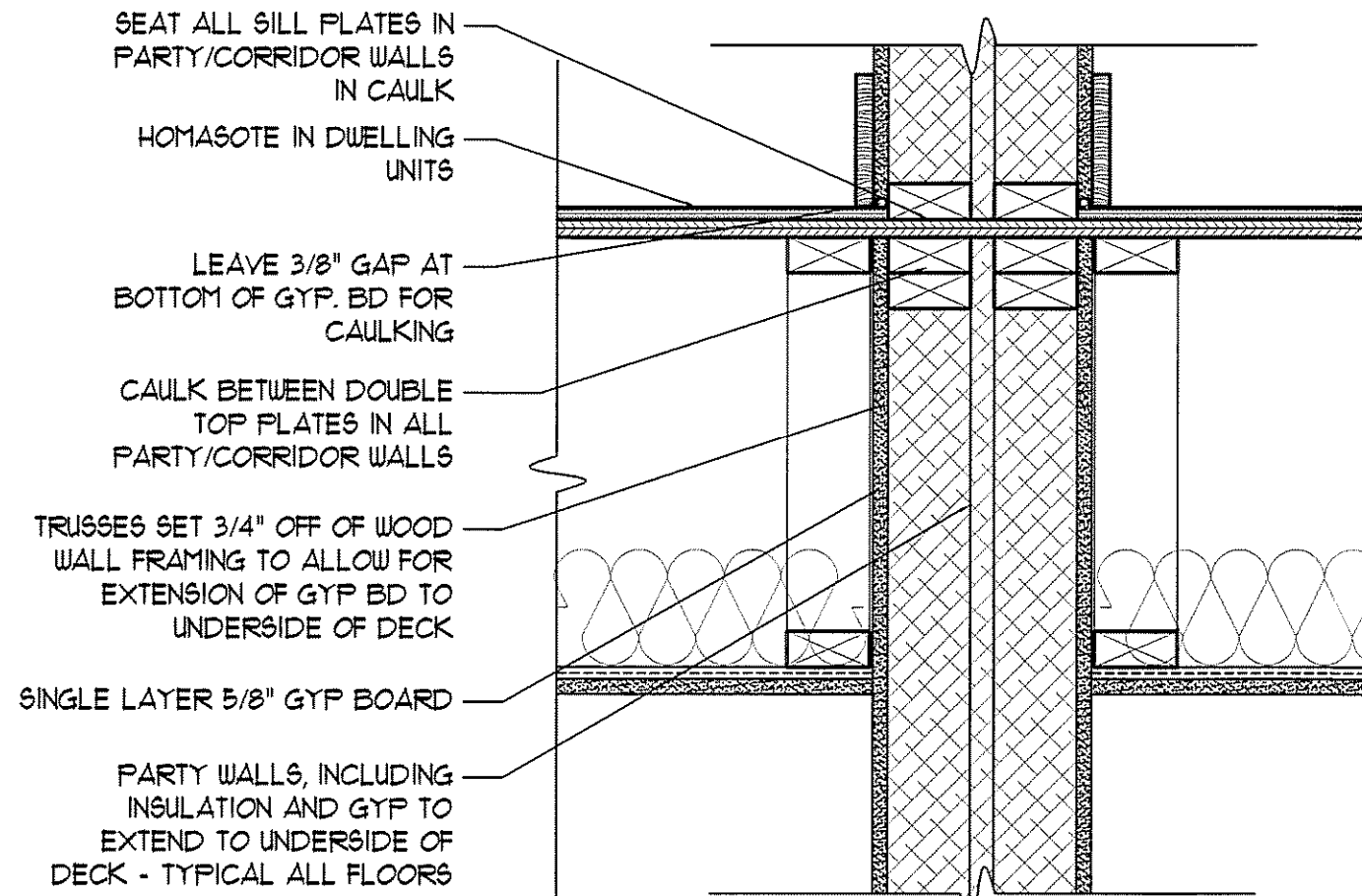

17 DETAIL AT TOP OF PARTY WALL  
SCALE: 1 1/2"=1'-0"

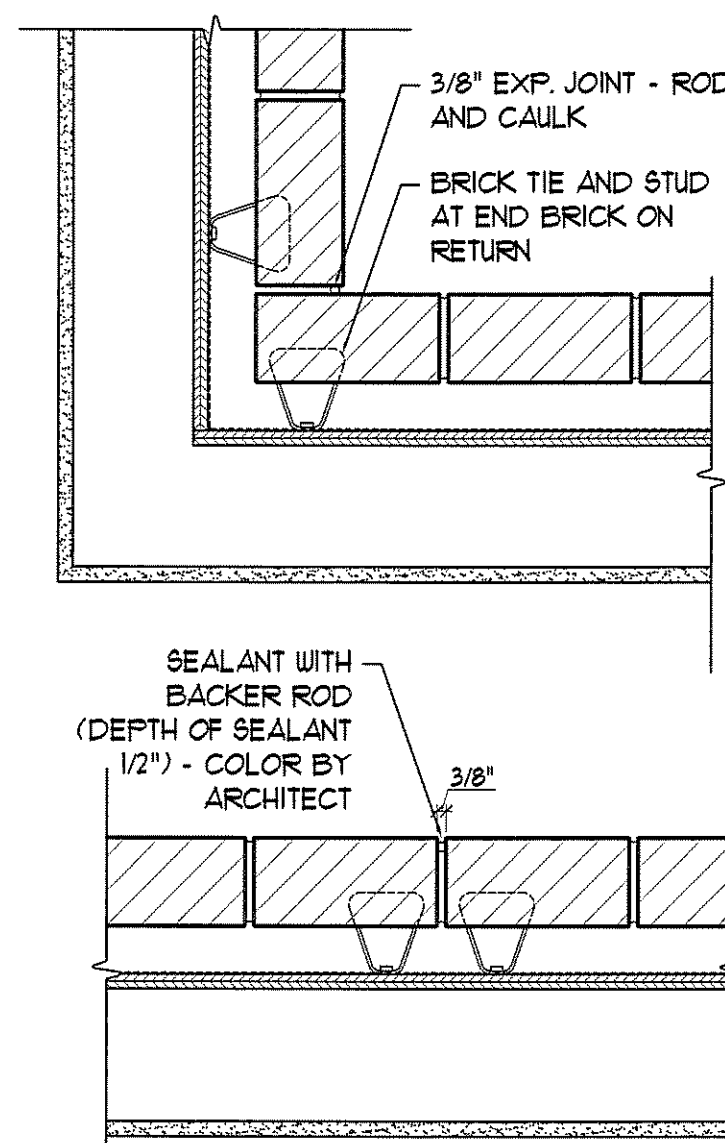

14 BRICK EXPANSION JOINT DETAILS  
SCALE: 1 1/2"=1'-0"

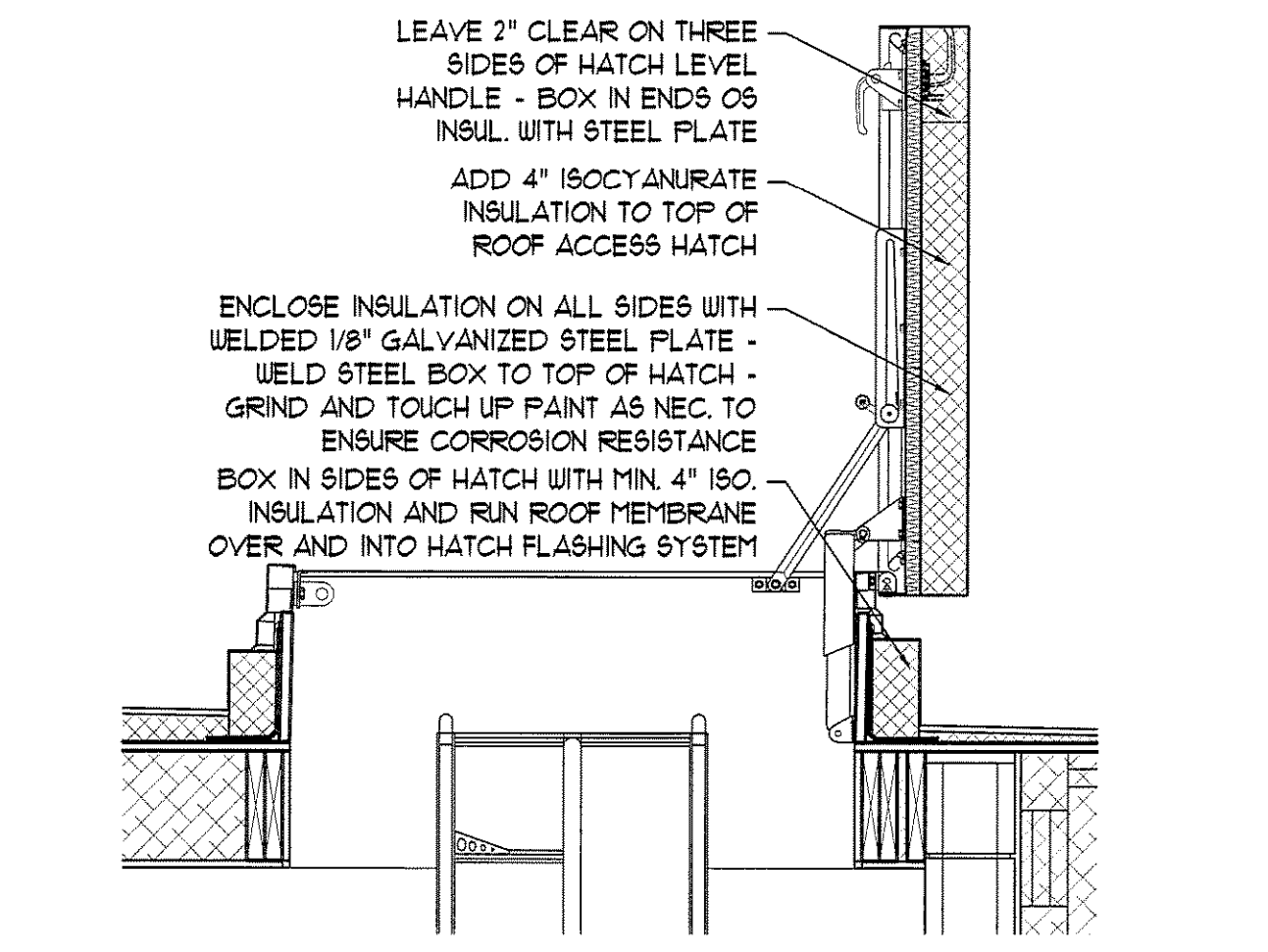

21 ROOF ACCESS HATCH DETAIL  
SCALE: 3/4"=1'-0"

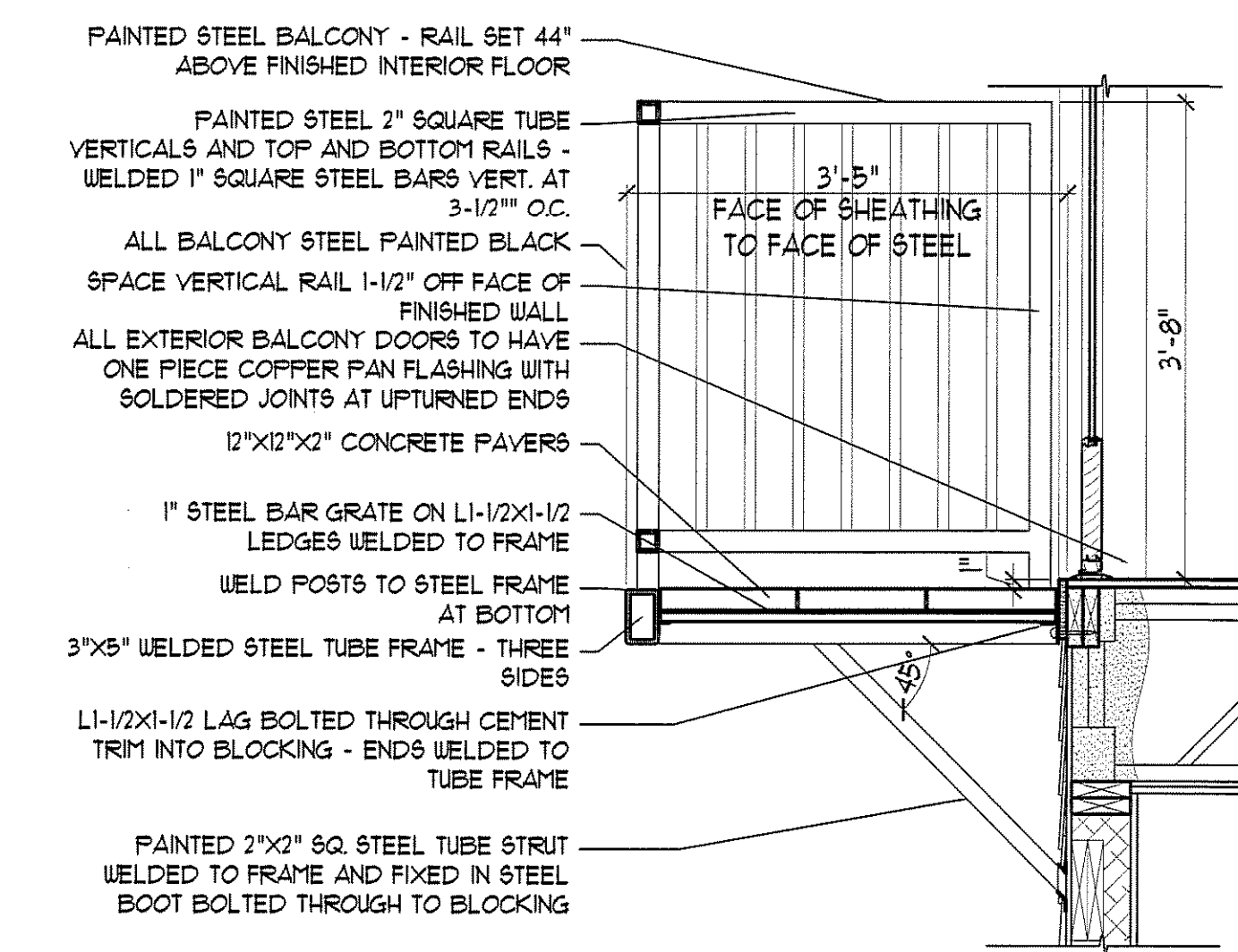

18 BALCONY DETAIL  
SCALE: 3/4"=1'-0"

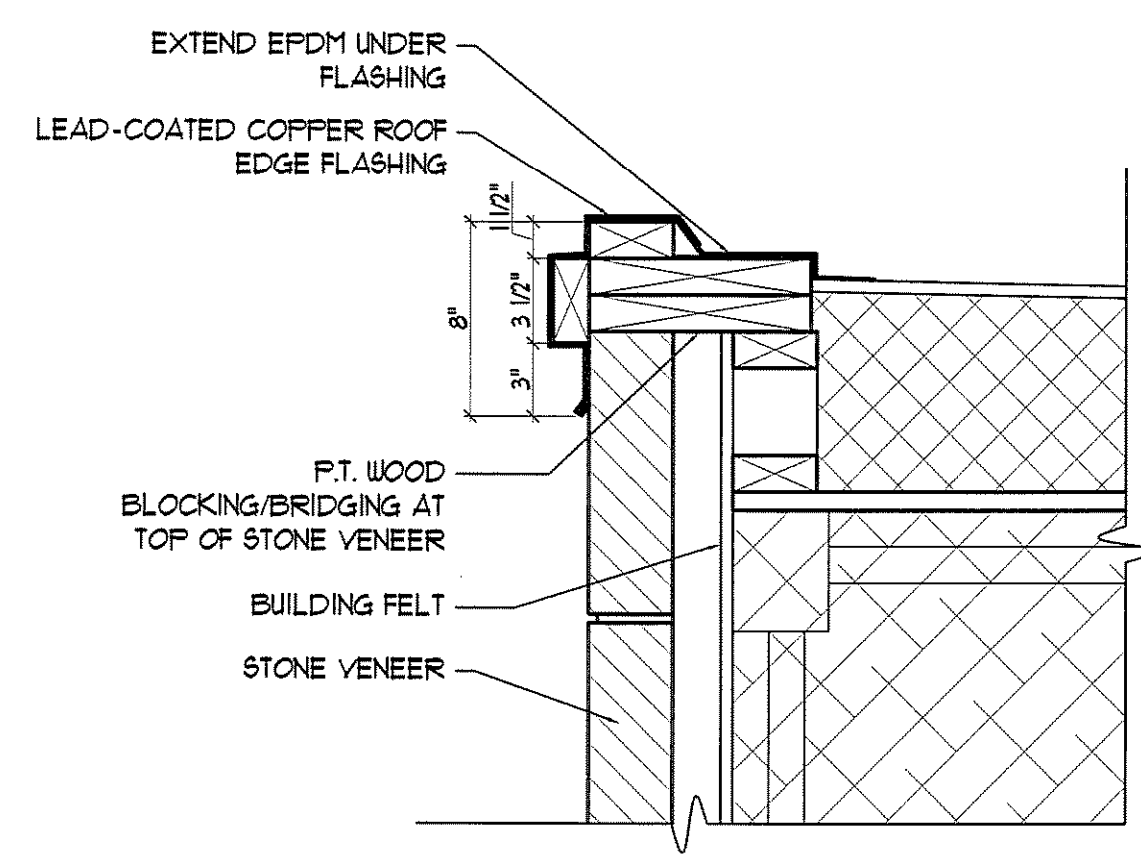

15 ROOF EDGE DETAIL  
SCALE: 1 1/2"=1'-0"

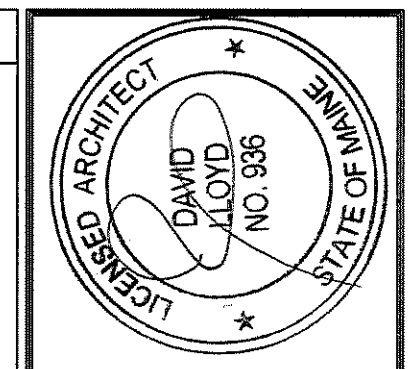

OWNER:  
53 DANFORTH STREET, LP  
C/O THE SZANTON COMPANY  
ONE CITY CENTER - 4TH FLOOR  
PORTLAND, ME 04101

ARCHETYPE, P.A.  
ARCHITECTS  
48 Union Wharf Portland, Maine 04101  
(207) 772-6022 Fax (207) 772-4056

Project:  
53 DANFORTH  
53 DANFORTH STREET  
PORTLAND, MAINE

Revisions:  
28 May 2008 - 50% MSHA Submittal  
1 July 2008 - 90% MSHA Submittal  
15 July 2008 - Pricing Set  
25 July 2008 - 100% MSHA Submittal

Date: 28 May 2008  
Scale: VARIES  
DETAILS

A5.02