

* WHERE TENDON CURVATURE EXCEEDS 1:12 SEE

L
64.01

A
64.03

TENDON PLACEMENT AT OPENING 24" OR LARGER

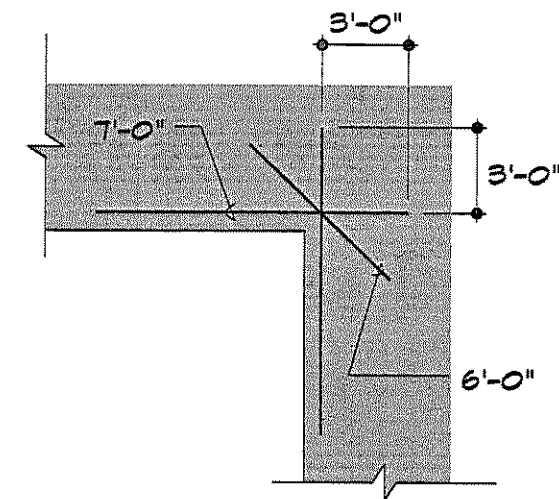

1 #5 TOP & BOTTOM AS SHOWN TYP. UNO

B
64.03

TRIM BARS AT RE-ENTRANT CORNERS

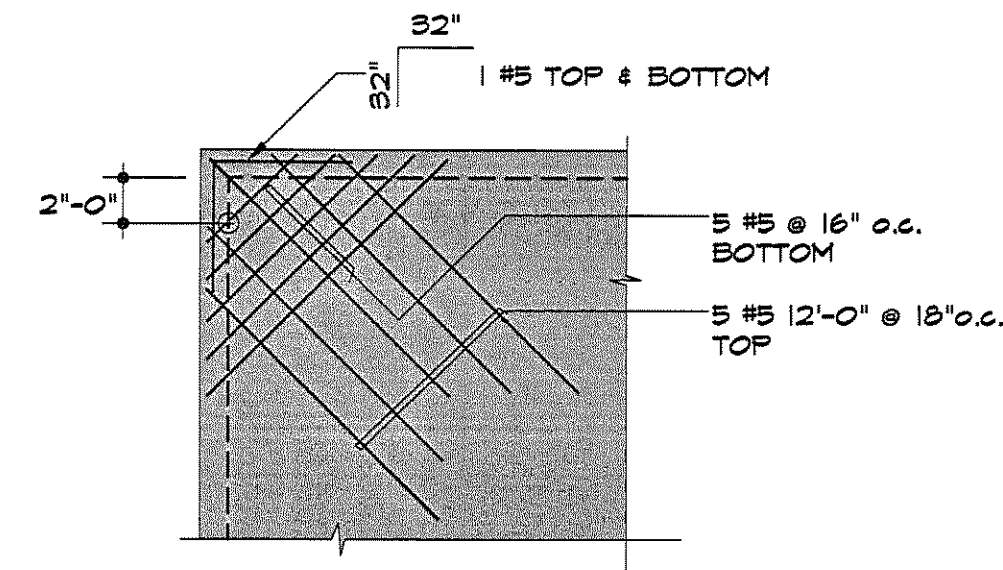

C
64.03

TRIM BARS AT SUPPORTED SLAB EDGES

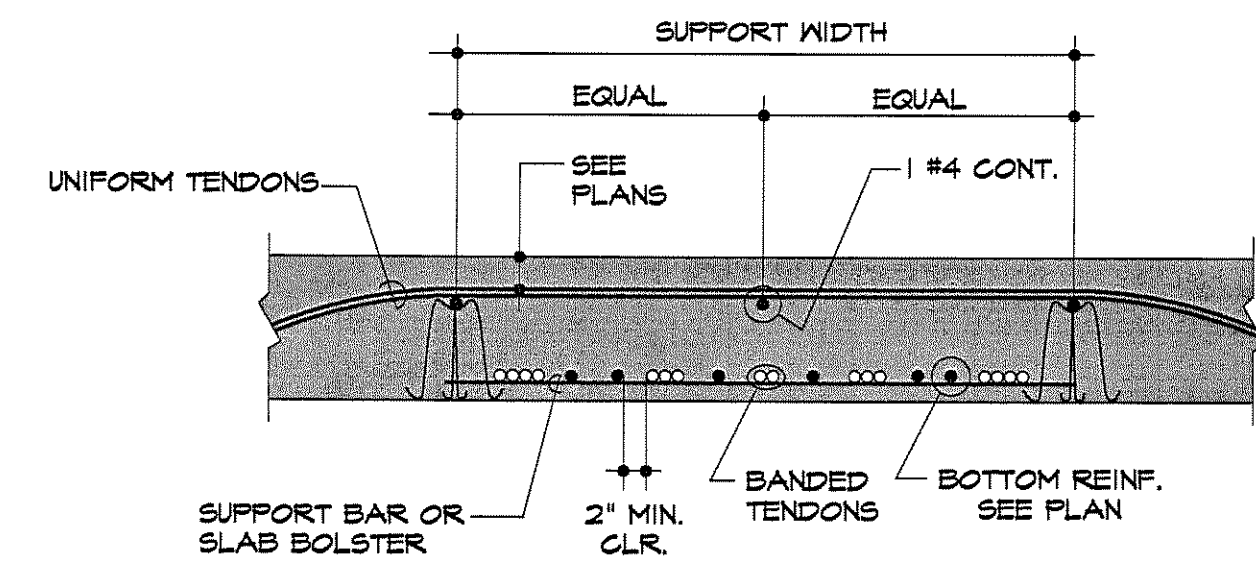

D
64.03

SECTION - BANDED TENDONS AT MID-SPAN

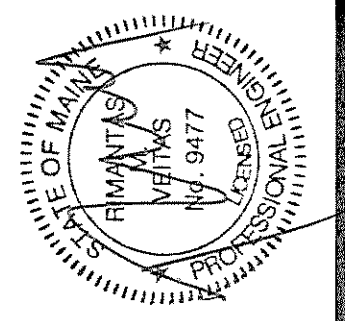

OWNER:
53 DANFORTH STREET, LP
C/O THE SZANTON COMPANY
ONE CITY CENTER - 4TH FLOOR
PORTLAND, ME 04101

ARCHETYPE, P.A.
ARCHITECTS
48 Union Wharf Portland, Maine 04101
(207) 772-6022 Fax (207) 772-4056

53 DANFORTH
53 DANFORTH STREET
PORTLAND, MAINE

Revisions:

28 May 2008	- 50% MSHA Submittal
01 July 2008	- 90% MSHA Submittal
15 July 2008	- Pricing Set
25 July 2008	- 100% MSHA Submittal

Date: 28 May 2008
Scale: 1/8" = 1'-0"
POST-TENSIONING
SECTIONS & DETAILS

S4.03