

Page 11 Intake for Specs

FAN #2 AI-G10 - SUPPLY FAN

1. UNTEMPERED SUPPLY UNIT WITH 10" BLOWER IN SIZE #1 HOUSING
2. INTAKE HOOD WITH EZ FILTERS
3. SIDE DISCHARGE - AIR FLOW RIGHT -> LEFT
4. FULL CRATING FOR UNTEMPERED FANS FOR SHIPPING.
5. 3 YEAR EXTENDED WARRANTY FOR FAN MOTOR, PARTS ONLY; DOES NOT INCLUDE LABOR.
6. EXTRA SET OF V-BELTS, ONLY TO BE ORDERED AS FAN OPTION AT TIME FAN IS ORDERED.
7. GRAVITY BACK DRAFT DAMPER, 16" WIDE X 18" HIGH, STANDARD GALVANIZED CONSTRUCTION, 1 1/4" REAR FLANGE, FOR SIZE 1 UNTEMPERED FAN HOUSING (S18)
8. WALL MOUNT OPTION FOR SIZE 1 UN-TEMPERED MAKE-UP AIR FAN. 32' LONG ANGLE IRON FRAME.

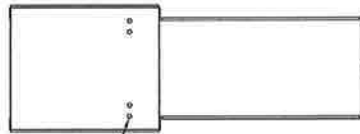

FLEX CONDUIT FOR FIELD WIRING

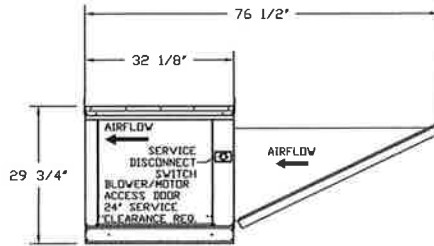
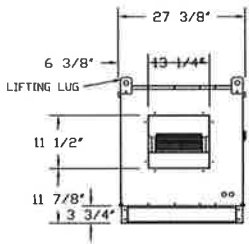

Untempered Supply Fan Wall Mount Bracket Detail

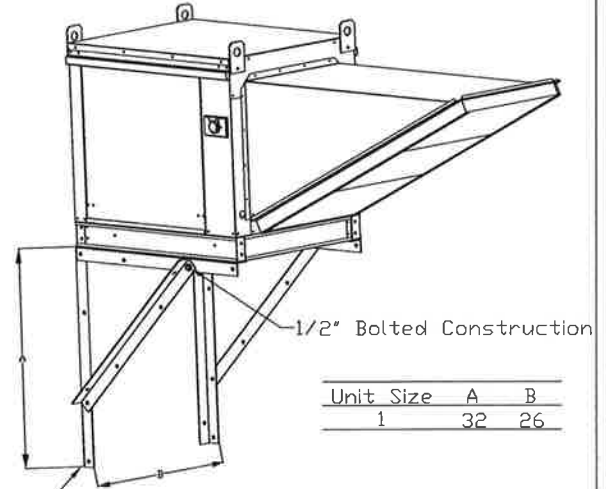

Unit Size	A	B
1	32	26

2" x 2" 10 GA Galv Angle

CUSTOMER APPROVAL TO MANUFACTURE:

Approved as Noted
 Approved with NO Exception Taken
 Revise and Resubmit
 SIGNATURE _____
 Your Title _____ Date _____



CAPTIVEAIR

JOB Taco Escobarr
 LOCATION Lewiston, ME.
 DATE 7/28/2016 JOB # 2729366
 DWG # 5 DRAWN BY BFC-21
 REV. SCALE 3/8" = 1'-0"